

**ADVANCED DISTRIBUTED
SIMULATION TECHNOLOGY II**

(ADST II)

BICEP-TC (DO #0049)

CDRL AB02

FINAL REPORT

30 August 1999



For:

United States Army
Simulation, Training, and Instrumentation Command
12350 Research Parkway
Orlando, Florida 32826-3224
Attn: (Gene Haga)

By:

19991115 060

Science Applications International
Corporation
12479 Research Parkway
Orlando, FL 32826-3248



Lockheed Martin
Information Systems Company
12506 Lake Underhill Road
Orlando, FL 32825

LOCKHEED MARTIN



REPORT DOCUMENTATION PAGEForm Approved
OMB No. 074-0188

Public reporting burden for this collection of information is estimated to average 1 hour per response, including the time for reviewing instructions, searching existing data sources, gathering and maintaining the data needed, and completing and reviewing this collection of information. Send comments regarding this burden estimate or any other aspect of this collection of information, including suggestions for reducing this burden to Washington Headquarters Services, Directorate for Information Operations and Reports, 1215 Jefferson Davis Highway, Suite 1204, Arlington, VA 22202-4302, and to the Office of Management and Budget, Paperwork Reduction Project (0704-0188), Washington, DC 20503

1. AGENCY USE ONLY (Leave blank)		2. REPORT DATE 23 JAN 1998	3. REPORT TYPE AND DATES COVERED final	
4. TITLE AND SUBTITLE Advanced Distributed Simulation Technology II (ADST-II) BICEP-TC (DO #0049) Final Report			5. FUNDING NUMBERS N61339-96-D-0002	
6. AUTHOR(S)				
7. PERFORMING ORGANIZATION NAME(S) AND ADDRESS(ES) Lockheed Martin Information Systems ADST-II P.O. Box 780217 Orlando Fl 32878-0217			8. PERFORMING ORGANIZATION REPORT NUMBER ADST-II-CDRL-BICEP-9900233	
9. SPONSORING / MONITORING AGENCY NAME(S) AND ADDRESS(ES) NAWCTSD/STRICOM 12350 Research Parkway Orlando, FL 32328-3224			10. SPONSORING / MONITORING AGENCY REPORT NUMBER	
11. SUPPLEMENTARY NOTES				
12a. DISTRIBUTION / AVAILABILITY STATEMENT Approved for Public release; distribution is unlimited				12b. DISTRIBUTION CODE
13. ABSTRACT (<i>Maximum 200 Words</i>) Battlespace Integrated Concept Emulation Program Test Cell (BICEP-TC) began as a Unilateral Delivery Order (UDO) in support of Fort Hood's SIMulation EXercise (SIMEX) II in 1997. It transformed into a standard Delivery Order (DO) #0049 under the Advanced Distributed Simulation Technology II (ADST II) contract administered by the U.S. Army Simulation Training and Instrumentation Command (STRICOM). U. S. Army Aviation Center (USAAVNC), Fort Rucker, AL sponsored the initial work. Army National Guard and PEO Aviation provided additional funds. The BICEP-TC grew from previously reported work of the Ft. Hood deployment. It replaced Government furnished equipment (GFE) with contractor provided items for the Mission Control Center (MCC), added the third manned simulator, refined the final packaging, hardware and software of the Reconfigurable Tactical Trainers (RTT), and integrated everything in a 53 foot commercial trailer. The package has been used in cooperative training environments with the Close Combat Tactical Trainer (CCTT), both fixed site and mobile units through a BICEP-TC network gateway. The system has deployed to several Army National Guard sites for training and has validated the concepts of the Aviation Combined Arms Tactical Trainer (AVCATT). It has been used for train-up of forces deploying to Bosnia.				
14. SUBJECT TERMS STRICOM, ADST-II, BICEP, simulation, SIMEX, C2, FT. HOOD				15. NUMBER OF PAGES 19
				16. PRICE CODE
17. SECURITY CLASSIFICATION OF REPORT UNCLASSIFIED	18. SECURITY CLASSIFICATION OF THIS PAGE UNCLASSIFIED	19. SECURITY CLASSIFICATION OF ABSTRACT UNCLASSIFIED	20. LIMITATION OF ABSTRACT	

Approved for public release; distribution is unlimited

Report Documentation Page	1. Report No.	2.	3. Recipient's Accession No.
4. Title and Subtitle: ADST II BICEP DO (#0049) Final Report			5. Report Date: 12/12/97
7. Author(s) John B. Abernathy			6.
9. Performing Organization Name and Address Lockheed Martin Corporation ADST II 12506 Lake Underhill Road Orlando, FL 32825			8. Performing Organization Rept. No. ADST II-CDRL-BICEP-9900233
12. Sponsoring Organization Name and Address NAWCTSD/STRICOM 12350 Research Parkway Orlando, FL 32826-3224			10; Project/task/Work Unit No.
15. Supplementary Notes			11. Contract(C) or Grant(G) No. (C) N61339-96-D-0002 (G)
16. Abstract (Limit 200 words) Battlespace Integrated Concept Emulation Program Test Cell (BICEP-TC) began as a Unilateral Delivery Order (UDO) in support of Fort Hood's Simulation EXercise (SIMEX) II in 1997. It transformed into a standard Delivery Order (DO) #0049 under the Advanced Distributed Simulation Technology II (ADST II) contract administered by the U.S. Army Simulation Training and Instrumentation Command (STRICOM). U. S. Army Aviation Center (USAAVNC), Fort Rucker, AL sponsored the initial work. Army National Guard and PEO Aviation provided additional funds. The BICEP-TC grew from previously reported work of the Ft. Hood deployment. It replaced Government furnished equipment (GFE) with contractor provided items for the Mission Control Center (MCC), added the third manned simulator, refined the final packaging, hardware and software of the Reconfigurable Tactical Trainers (RTT), and integrated everything in a 53 foot commercial trailer. The package has been used in cooperative training environments with the Close Combat Tactical Trainer (CCTT), both fixed site and mobile units through a BICEP-TC network gateway. The system has deployed to several Army National Guard sites for training and has validated the concepts of the Aviation Combined Arms Tactical Trainer (AVCATT). It has been used for train-up of forces deploying to Bosnia.			13. Type of Report & Period Covered Final Report
17. Document Analysis a. Descriptors BICEP; Virtual Simulation; Reconfigurable simulators; Command and Control; Collective task training b. Identifiers/Open -Ended Terms c. COSATI Field/Group			14.
18. Availability Statement A - Approved for public release; distribution is unlimited	19. Security Class (This Report) UNC		21. No. of Pages
	20. Security Class (This Page) UNC		22. Price

Approved for public release; distribution is unlimited

Table of Contents

1	INTRODUCTION	1
1.1	PURPOSE	1
1.2	CONTRACT OVERVIEW	1
1.3	REPACKAGING OVERVIEW	1
2	APPLICABLE DOCUMENTS	1
2.1	GOVERNMENT	1
2.2	NON-GOVERNMENT	1
3	SYSTEMS DESCRIPTION	2
3.1	SYSTEM CONFIGURATION AND LAYOUT	2
3.1.1	<i>Trailer</i>	2
3.1.2	<i>Mission Control Center (MCC)</i>	4
3.1.3	<i>Reconfigurable Tactical Trainer (RTT)</i>	6
3.1.3.1	The Cockpit.....	6
3.1.3.2	The Base Frame Unit - Front	6
3.1.3.3	The Base Frame Unit - Rear.....	6
3.1.4	<i>Network</i>	9
3.1.5	<i>Software Baseline</i>	10
3.1.5.1	RTT Computers	10
3.1.5.1.1	Simulation Host Computer.....	10
3.1.5.1.2	Main Instrument Panel (MIP) Computers	10
3.1.5.1.3	Center Console Computer	11
3.1.5.1.4	Visual Computer	11
3.1.5.1.5	Control Loading Computer	11
3.1.5.1.6	Communications/Aural Cue Computer	11
3.1.5.2	MISSION CONTROL CENTER.....	11
3.1.5.2.1	SAF Computer	11
3.1.5.2.2	Stealth Computer.....	12
3.1.5.2.3	After Action Review Computer	12
3.1.5.2.4	Communications Computer.....	12
3.1.6	<i>Commercial Software</i>	12
3.2	DATABASE AND SCENARIO DEVELOPMENT.....	13
4	INTEGRATION AND TEST STRATEGY	13
5	CONDUCT OF THE EXERCISES	13
6	OBSERVATIONS AND LESSONS LEARNED	13
6.1	ADMINISTRATIVE	13
6.2	SITE INTEGRATION AND EXERCISE SUPPORT	15
7	CONCLUSION	16
8	ACRONYMS	16

LIST OF FIGURES

FIGURE 3-1. BICEP MOBILE UNIT (TRAILER) (SHEET 1 OF 2).....3
FIGURE 3-2. BICEP MOBILE UNIT (TRAILER) (SHEET 2 OF 2).....3
FIGURE 3-3. MISSION CONTROL CENTER LAYOUT5
FIGURE 3-4. RECONFIGURABLE TACTICAL TRAINER (SHEET 1 OF 3)7

LIST OF TABLES

TABLE 3-1 - COTS SOFTWARE COMPONENTS AND VERSION INFORMATION 12

EXECUTIVE SUMMARY

This report concentrates on describing the systems mounted in a trailer to demonstrate the viability of reconfigurable aviation devices for collective task training. The Battlespace Integrated Concept Emulation Program Test Cell (BICEP-TC) began as a Unilateral Delivery Order (UDO) in support of Fort Hood's SIMulation EXercise (SIMEX) II in 1997. It was transformed into a standard Delivery Order (DO) #0049 under the Lockheed Martin Advanced Distributed Simulation Technology II (ADST II) contract administered by the U.S. Army Simulation Training and Instrumentation Command (STRICOM). The Directorate of Training, Doctrine and Simulation (DOTDS), U. S. Army Aviation Center (USAAVNC), Fort Rucker, AL sponsored the initial work. Army National Guard and PEO Aviation provided additional funds.

This report addresses the simulations, communications networks, and trailer configuration developed to support the mobile training device concept, i.e., the test cell. The BICEP-TC drew concepts from the previously reported work of the Ft. Hood deployment. It replaced Government furnished equipment (GFE) with contractor provided items for the Mission Control Center (MCC), added the third manned simulator, refined the final packaging, hardware and software of the Reconfigurable Tactical Trainers (RTT), and integrated everything in a 53 foot commercial trailer. The package has been used in cooperative training environments with the Close Combat Tactical Trainer (CCTT), both fixed site and mobile unit. This was accomplished through a BICEP-TC network gateway. The system has deployed to several Army National Guard sites for training and has validated the concepts of the Aviation Combined Arms Tactical Trainer (AVCATT). It has been used for train-up of forces deploying to Bosnia.

1 INTRODUCTION

1.1 Purpose

The purpose of this report is to document the ADST II effort, which supported the Battlespace Integrated Concept Emulation Program Test Cell (BICEP-TC) Delivery Order (DO) and specifically capture the equipment configuration, observations, and lessons learned. This document does not address the operational effectiveness of the various systems or specific results of any exercises.

1.2 Contract Overview

This appendix addresses the third and final part of DO #0049, which is a proof-of-principle under the Lockheed Martin Corporation (LMC) ADST II contract with STRICOM. The objective was to provide residual capability that could be used by both active and reserve components as a training system and repackage the equipment into a mobile configuration.

1.3 Repackaging Overview

The BICEP equipment was repackaged into a mobile configuration and put into service as a proof of principle training system. The system was deployed to various National Guard sites as a stand alone device. It has been used in several trade shows, including the Army Aviation of America Association (AAAA), and Association of US Army (AUSA) annual conventions. It has been connected with the Army's Close Combat Tactical Trainer (CCTT), fixed site at Ft. Hood, TX, and a mobile unit at the National Guard Association Convention in Milwaukee, WI. Finally, it has been used for train-up of forces deploying to Bosnia.

2 APPLICABLE DOCUMENTS

2.1 Government

ADST II Statement of Work for the Battlespace Integrated Concept Emulation Program Test Cell (BICEP-TC) Delivery Order, AMSTI-97-W048 Rev F, 28 August 1998.

2.2 Non-Government

Mini-Feasibility Analysis Study (MFAS) for the Battlespace Integrated Concept Emulation Program Test Cell (BICEP-TC) Delivery Order #0049 ADST-II-CDRL-BICEP-9700354, 19 August 1997.

3 Systems Description

3.1 System Configuration and Layout

Details of the system configuration and layout are available in the system description documentation in the ADST II Library (CDRL AB03). BICEP-TC was designed to meet the allowable space requirements of a commercial 53 foot trailer. There are three major equipment systems to the BICEP-TC: the Trailer, the Mission Control Center (MCC), the Reconfigurable Tactical Trainer (RTT), which is comprised of the Cockpit and the Base Frame Unit. The cockpit is the reconfigurable component. It can represent the UH-60A, the OH-58D, or the AH-64A.

3.1.1 Trailer

The trailer is a self-contained unit, which houses the BICEP-TC, providing environmental conditioning and electrical power hookups for the MCC and the RTT units, which are contained within. Figure 3-1 is an illustration of the trailer and how it houses the MCC and RTT units. Electrical power is supplied externally through the circuit breakers in the front Belly Box of the Trailer. There are three exterior access doors on the curbside of the trailer, which allow access to the RTT units from the outside. On the roadside of the trailer there are four sets of double doors through which the RTT and the MCC are placed into the trailer.

The MCC is at the back end of the trailer mounted on a table and strapped to the wall of the trailer for safety of equipment when transporting. There are two benches in front of the MCC with allow student or observers of the operation of the MCC. The RTTs occupy the remaining room in the trailer and are accessible only from outside the trailer by the steps and platforms provided for that reason. Each access door has an observer fold down seat mounted on the door for an instructor or an observer.

Two six ton Environmental Conditioning Units (ECU) provide a stable environmental condition within the trailer. Detailed information on the units is contained in the Vendor's Manual for the trailer.

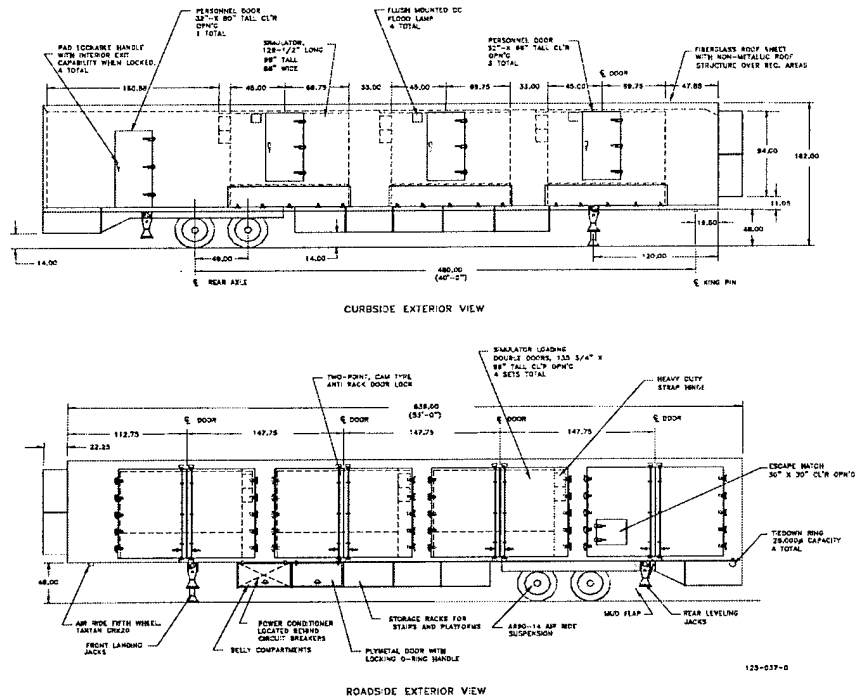

Figure 3-1. BICEP Mobile Unit (Trailer) (Sheet 1 of 2)

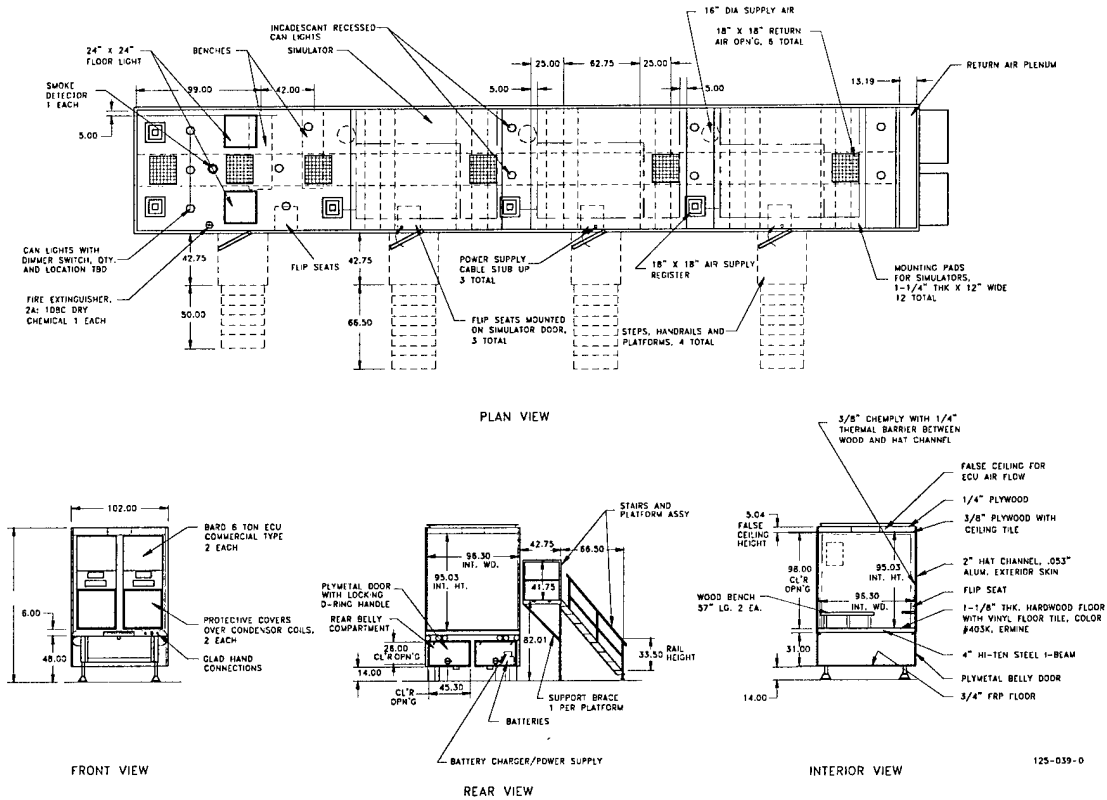

Figure 3-2. BICEP Mobile Unit (Trailer) (Sheet 2 of 2)

3.1.2 Mission Control Center (MCC)

The MCC, Figure 3-2, is the station where the training and/or tactical mission is controlled, executed and observed. There are six monitors, three computers, a video recorder, a microphone, communications switch, and Extron Matrix 200 Series video switch, a series switch Autosync Video converter, a simulator, a stackable hub, and three video splitters in the Mission Control Center. These items of equipment are mounted on a table rack at the extreme rear of the trailer. In the MCC there are two benches for students or observers.

All monitors are connected through an Extron Matrix 200 Series video switch, as are the monitors from the Reconfigurable Tactical Trainers. As a result of this connection any video presentation can be switched to any monitor in the MCC. A video recorder allows the operator to select and record the video on any monitor he chooses. There are four computers in the MCC. First is the STEALTH, which allows a God's Eye View of the tactical situation. Second is the MODSAF, which allows the operator to change the tactical situation. Third is the After Action Review (AAR) computer, which records the overall scenario and allows playback for review by the instructors and students. Fourth is an ASTi computer, which controls communications (COMMS) between the MCC and the RTTs. A mouse device or a keyboard controls data input to the computers. In the case of the COMMS computer there is a channel selection device for control of inputs. The operator in the MCC has the capability to change the tactical scenario, and freeze or release the action in the RTTs. He can use audio communications to direct operations and act as a role player, and he can use the video switch to view the action, which is taking place in the RTTs.

30 August 1999

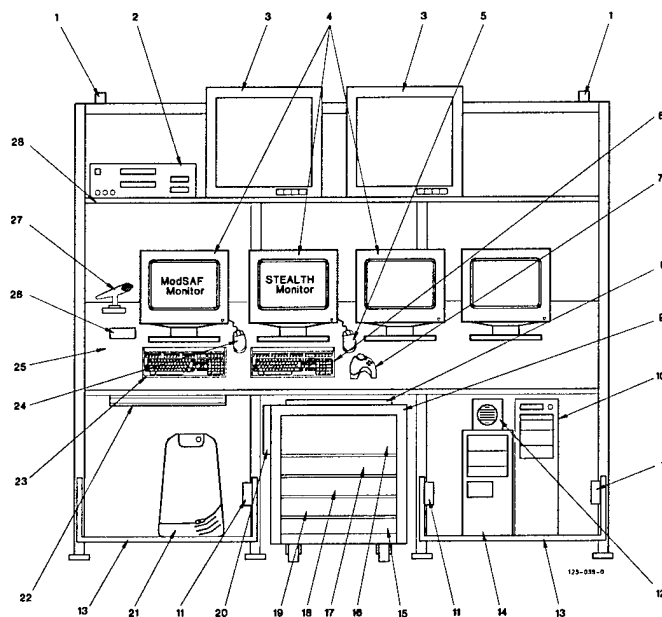

- | | |
|----------------------------------|--|
| 1. Speaker (Tweeter) | 15. Video Sync |
| 2. Video Recorder | 16. Matrix 2000 Series Switch |
| 3. Out-The-Window (OTW) Monitors | 17. Model 9400SR Autosync Converter |
| 4. 20" Monitors | 18. ASTi Simulator (COMMS Computer) |
| 5. STEALTH Mouse | 19. SEH22 Hubstack |
| 6. STEALTH Keyboard | 20. COMMS Hub |
| 7. STEALTH Trackball | 21. After Action Review (AAR) Computer |
| 8. COMMS Keyboard | 22. AAR Keyboard |
| 9. 19" Wheeled Rack | 23. ModSAF Keyboard |
| 10. STEALTH Computer | 24. ModSAF Mouse |
| 11. Video Splitter | 25. 90"x36" Table |
| 12. Speaker (Woofers) | 26. COMMS Switch |
| 13. 16" Deep Lower Shelf | 27. COMMS Microphone |
| 14. ModSAF Computer | 28. 24" Deep Upper Shelf |

Figure 3-3. Mission Control Center Layout

3.1.3 Reconfigurable Tactical Trainer (RTT)

The RTT, Figure 3-3, is composed of two sections: the Cockpit and the Base Frame Unit.

3.1.3.1 The Cockpit

The cockpit (Figure 3-3, Sheet 1 of 3) provides for multiple configuration training, but does not actually replicate the cockpit of any of the supported aircraft types. It houses equipment/components necessary to meet operational and fidelity requirements. General cockpit equipment includes those items that apply to all three configurations. Specific aircraft type equipment includes those items that are applicable only to a specific aircraft configuration. The RTT cockpit is designed to be easily reconfigurable to support training/evaluation requirements for the UH-60A, OH-58D and AH-64A aircraft, using the displays and bezels provided.

The crew area of the cockpit houses both general and aircraft-specific components. General cockpit equipment includes items such as seat assemblies, instrument/cockpit management displays/touch screens, bezel/panel stowage areas. Aircraft-specific equipment includes items such as the appropriate bezel assembly (instrument overlay), grips, pedals, functional or non-functional panels, instrument/cockpit management presentations. Figure 3-3, Sheet 1 of 3 is a line drawing of the internal view of the cockpit. This cockpit houses the Out-the-Window Displays (OTW) for both the pilot and copilot, the Left, Right and Center Main Instrument Panel (MIP) displays, the collective and cyclic sticks, and control pedals. The center console allows for more instrumentation and the mission control pages as may be used by the instructor or students. There is cockpit lighting, emergency lighting, and Grimes lights for both pilot and copilot. The Helmet Mounted Display for pilot and copilot are also located in the cockpit as are the storage areas shown in Figure 3-3, Sheet 1 of 3.

3.1.3.2 The Base Frame Unit - Front

The electronics and mechanical equipment necessary to simulate flight conditions and to conduct training for the students are located in the Base Frame Unit (Figure 3-3, Sheet 2 of 3). The Base Frame Unit is external to the cockpit, but is an essential part of the RTT. The equipment in the base frame is adjacent to and mounted underneath the cockpit, and includes: AC/DC distribution panels, the graphics computer, control loading controls and computer, the HMD electronics package, the head tracker and the VMIC chassis. The IOS, the Host and the Left, Right and Center MIP computer cards are located in the VMIC chassis. The stackable hubs and the synchronizers are also located in the Base Frame Unit.

3.1.3.3 The Base Frame Unit - Rear

Figure 3-3, Sheet 3 of 3 is a rear view of the RTT. This displays the location of equipment accessible by opening the trailer roadside double doors. The monitor, image generator, speakers, control loading motors and associated equipment are all accessible from this location.

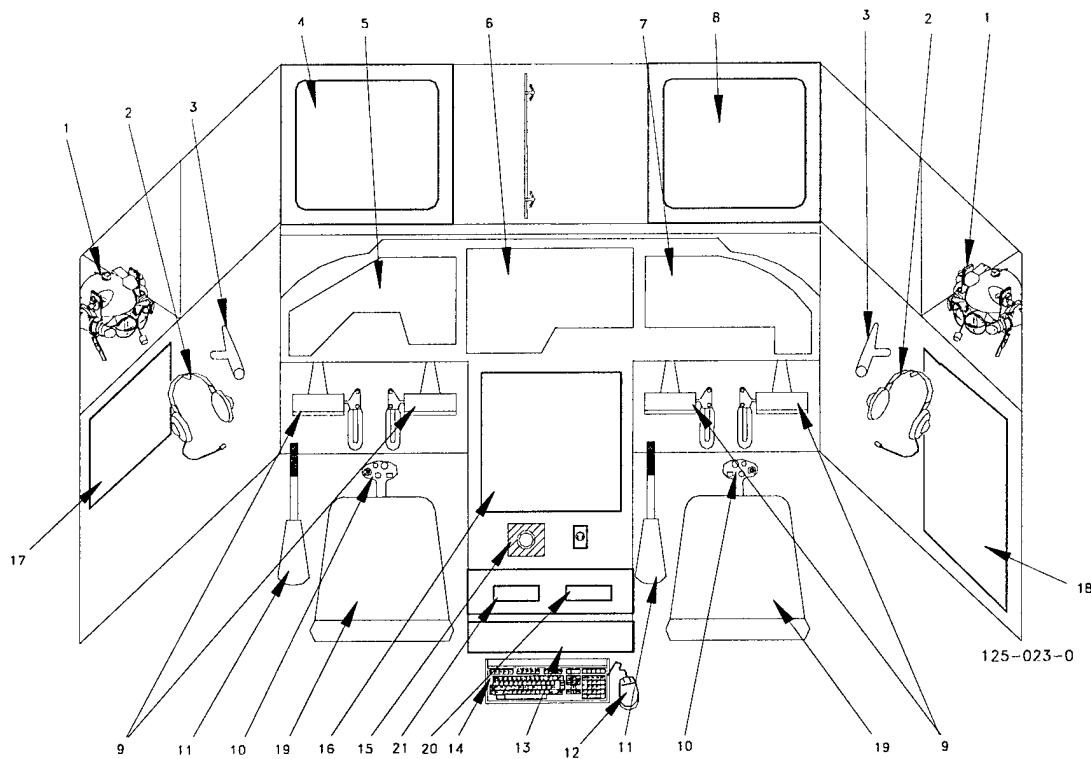

Cockpit (UH-60A shown)

- | | |
|---|---|
| 1. Helmet Mounted Displays | 12. Trackball Mouse |
| 2. Headsets | 13. Drawer |
| 3. Grimes Lights | 14. Keyboard |
| 4. Left Out-The-Window Display | 15. Emergency Stop |
| 5. Left Main Instrument Panel w/Bezel | 16. 20.1 LCD Center Console |
| 6. Center Main Instrument Panel Display w/Bezel | 17. CRT Storage |
| 7. Right Main Instrument Panel Display w/Bezel | 18. Maintenance Crawl Space Access Door |
| 8. Right Out-The-Window Display | 19. Aircrew Seats |
| 9. Pedals | 20. 120 MB Floppy Drive |
| 10. Cyclic | 21. CD ROM |
| 11. Collective | |

Figure 3-4. Reconfigurable Tactical Trainer (Sheet 1 of 3)

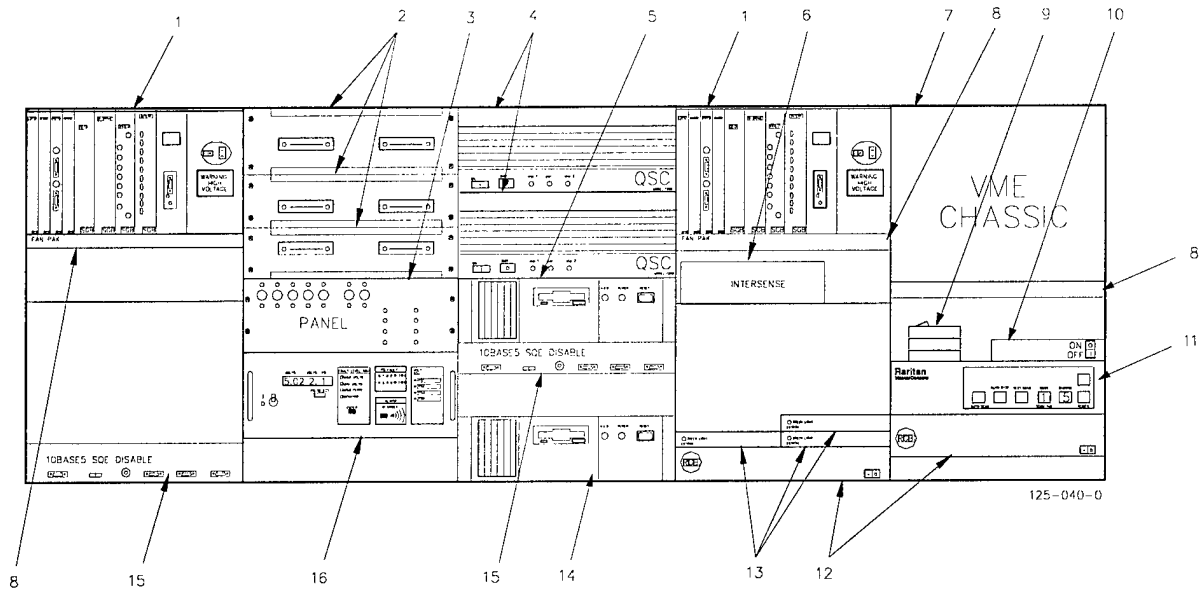

Base Frame Unit - Front

- | | |
|---|------------------------------|
| 1. HMD Electronics Unit | 9. Video Splitters |
| 2. Digital Input and Analog Input Transition Panels | 10. Modem |
| 3. DC Transformers | 11. Computer Terminal Switch |
| 4. Audio Amplifiers | 12. Chroma Key Video Insert |
| 5. COMM/Aural Computer | 13. SYNC Combiners |
| 6. Intersence Head Tracker | 14. Control Loading Computer |
| 7. VME Chassis | 15. Ethernet Hub |
| 8. Fan Pack | 16. DC Voltage Panel Supply |

Figure 3-3. Reconfigurable Tactical Trainer (Sheet 2 of 3)

30 August 1999

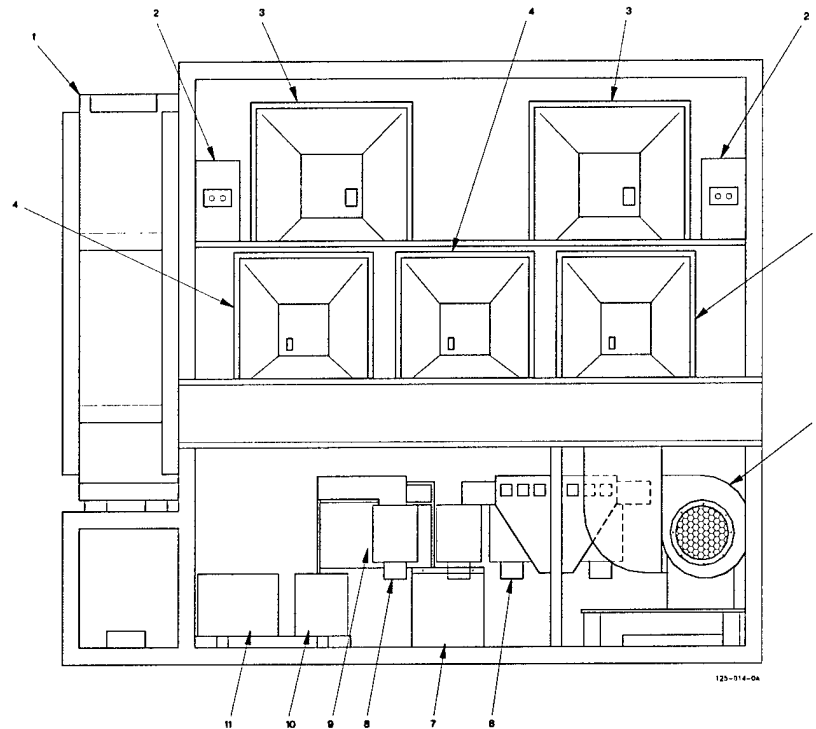

Base Frame Unit - Rear

- | | |
|--|-------------------------------------|
| 1. Silicon Graphics Image Generator (IG) | 7. Control Loading Servo |
| 2. Speakers - Aural Cue | 8. Control Loading Control Pedals |
| 3. Out-The-Window Displays | 9. Control Loading Cyclic Pitch |
| 4. Main Instrument Panel Displays | 10. AC Terminal for Control Loading |
| 5. Blower | 11. Power for Control Loading |
| 6. Control Loading Cyclic Lateral | |

Figure 3-3. Reconfigurable Tactical Trainer (Sheet 3 of 3)

3.1.4 Network

Figure 3-4 depicts the network used in the BICEP-TC. The basic configuration is a single self-contained Ethernet network running the DIS 2.04 protocol. On occasion, we have separated the simulator network traffic from the voice radio traffic in the interest of reducing the amount of traffic on a single network. This was used when we connected BICEP-TC to CCTT. In this instance, we had to use gateways to connect the two versions of the DIS protocol. The trailer has an external interface through a hub that allows it to immediately join an outside local area network (LAN) or wide area network (WAN).

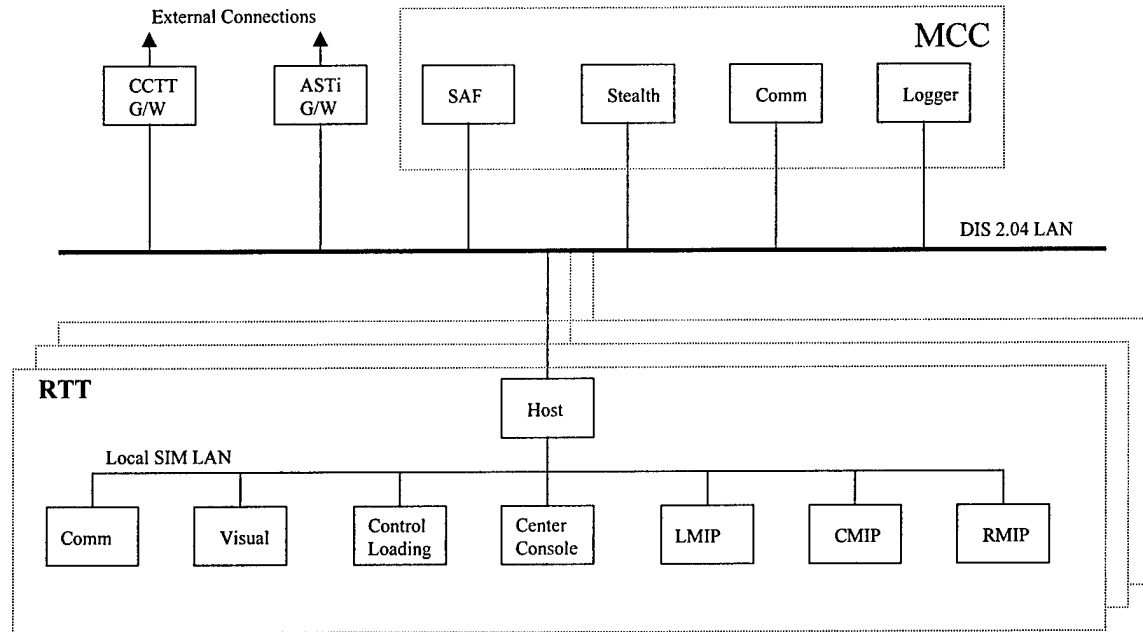

Figure 3-4. Network Architecture

3.1.5 Software Baseline

3.1.5.1 RTT Computers

Each RTT consists of the following computational units:

- Simulation host computer
- Main Instrument Panel (MIP) computers (left, center and right)
- Center console computer
- Visual computer
- Control loading computer
- Communications/aural cue computer

3.1.5.1.1 Simulation Host Computer

The simulation host computer contains the following software components:

1. Simulation application
2. DIS interface configuration file
3. Binary interpolation data files
4. Mission data files
5. Mission editor utility
6. Auto configuration utility
7. DORT utility

3.1.5.1.2 Main Instrument Panel (MIP) Computers

Each MIP application (left, center, and right) executes on a dedicated computer. The software organization on each of these three computers is identical except for the particular MIP application. As such, they are described here together.

The left (center, right) MIP computer contains the following software components:

OH-58 left (center, right) MIP application.
UH-60 left (center, right) MIP application.
AH-64A left (center, right) MIP application.
MIP auto start utility.
Network configuration data file.

3.1.5.1.3 Center Console Computer

The center console computer contains the following software components:

Center console/instrument panel application program.
Network configuration data file.
PDU filter application program.
PDU filter configuration data file.

3.1.5.1.4 Visual Computer

The visual computer contains the following software components:

IOS Control Interface Daemon
Host – Image Generator Communication Software
Base Image Generator Software
DIS Entity Management Software
Intersense Head Tracking Software

3.1.5.1.5 Control Loading Computer

The software components for the control loading computer are primarily COTS. Customized components residing on the computer are:

Control loading auto start utility.
Control loading startup files.
Control loading model data files.
Device physical characteristics configuration file.
Runtime parameters configuration file.

3.1.5.1.6 Communications/Aural Cue Computer

The software components for the communications and aural cue computer are primarily COTS. Customized components residing on the computer are:

Model files
Sound files

3.1.5.2 MISSION CONTROL CENTER

The MCC consists of the following computational units:

1. SAF computer
2. Stealth computer
3. After Action Review computer
4. Communications computer

3.1.5.2.1 SAF Computer

The SAF computer contains a standard installation of the GFE ModSAF application.

3.1.5.2.2 Stealth Computer

The Stealth computer contains a standard installation of the VSRG COTS application. In addition, the RTT Mission Editor utility is also installed on the Stealth computer.

The RTT mission editor utility is used to create and maintain mission data files used by the RTT devices.

3.1.5.2.3 After Action Review Computer

The After Action Review computer contains a standard installation of the Simulyzer COTS application.

3.1.5.2.4 Communications Computer

The Communications computer contains a standard installation of the ASTI communications application.

3.1.6 Commercial Software

There are numerous commercial software components in the BICEP-TC. The specific configurations are listed in Table 3-1.

Table 3-1 - COTS SOFTWARE COMPONENTS and VERSION INFORMATION

<u>Software Product</u>	<u>Version</u>	<u>Computer</u>
Simulyzer	1.5	AAR
IRIX	6.3	AAR
Model Builder Utilities	3.7	ASTI
Model Builder Installation	3.10d	ASTI
MS-DOS	6.2	ASTI, Control loading
Elo touch s/w	2	Center console
Electro-Load	4	Control loading
VMISFT-9450-006-910	2.12	Host
VMISFT-9420-006-910	4.03	Host
Microsoft Windows NT	4.0, build 1381	Host, MIPs, IOS
VMIC 7587 drivers disk set	n/a	Host, MIPs, IOS
MicroTouch s/w	1.21	MIPs
ModSAF	5.0	SAF
Linux	2.0.33	SAF
VSRG	2.2e	Stealth
MS Windows 95	OSR2	Stealth
Performa	2.2	Visual
IRIX	6.4	Visual

3.2 Database and Scenario Development

BICEP-TC has a variety of terrain databases. All have been derived from a common S1000 representation and converted into ModSAF CTDB (Compressed Terrain Database) format as well as MultiGen and MetaVR database (MDB) to fit specific component configurations. However, since they all came from the same S-1000 origin, they are registered in X and Y. Ground clamping has been used to keep entities on the surface when viewing through a visual system.

4 Integration and Test Strategy

BICEP-TC was integrated and tested through a series of incremental evaluations by subject matter experts (SME) from Ft. Rucker, AL. Representatives for each aircraft type worked with Reflectone engineers to define capabilities and evaluate how well the implementation represented the aircraft systems. As has been pointed out, the BICEP-TC does not fully represent any aircraft; it is a sub-set of functionality that is useful for collective task training. In addition to the SMEs, we had the opportunity to have input from Army National Guard and Active Component soldiers at Ft. Hood.

5 Conduct of the Exercises

Exercises or training events have generally proceeded as follows:

The system arrives at a location and is spotted and connected to the electrical power source. If we are to exercise with another simulation, we make the appropriate network connections and after we are satisfied that the trailer is operational, we begin coordinating terrain database and entity mappings with the site system. After we are satisfied that the two are operational, we are ready to train the using organization's crews. After a brief introduction to the systems and operation, the crews are assisted as they enter the cockpit and don the HMD system. After they are comfortable with the helmet, we show them what vehicles and other objects look like in the simulation and how to operate the weapons systems. They are then given approximately 30 minutes to an hour to fly around and become proficient in engaging targets as well as flying the aircraft. A post flight debriefing answers questions and the crews then depart for their tactical training events. When they reenter the cockpit on an assigned mission, the operation is in accordance with their briefing and procedures. The Battlemaster runs the exercise as directed by the unit commander.

6 Observations and Lessons Learned

The following discussion details the lessons learned from the experiences we have had. The lessons learned are looked at from an administrative and engineering perspective.

6.1 Administrative

Observation #1

Delivery Orders that run for long periods of performance will have personnel changes.

Discussion #1

The extended period of performance was such that we had personnel changes on all sides of the Integrated Product Team (IPT). Changes occurred on the Government team (STRICOM PD and Engineer and USAAVNC SMEs), ADST II team (Engineer and PMO team), and Reflectone team (PD, Lead Engineer, and other engineering staff members). As a result, there were several opportunities for misunderstanding and interpretation.

Lesson Learned #1

Keep written records of meetings and agreements made during IPT sessions.

Observation #2

Verification, Validation, and Accreditation (VV&A) are important.

Discussion #2

Although there was no contractual requirement for VV&A, it was necessary to run a self-checking VV&A just to get organized and ready to operate. Unfortunately, the lack of a formal effort made the process vulnerable to incomplete analysis and checking. There were several instances where information was confusing or wrong simply because there was no formal process to verify the model being used prior to its introduction. Demonstrations and to some extent loosely constructed training events can succeed without formal validation of the system. However, it was apparent that there would have been fewer instances of interruption and late night analysis if there had been a separate effort to check on the information being used in the exercise.

Lesson Learned #2

ADST II delivery orders that have a substantial equipment component or significant software development should have a VV&A task.

Observation #3

Configuration Management (CM) and Quality Assurance (QA) is essential in a simulation system of this complexity.

Discussion #3

Because of the contracting approach selected for this DO, we did not fund a formal CM or QA process by Reflectone. As a result, we were vulnerable to their engineering baseline and CM control, and self-inspection QA, which was not always complete. There were instances when we had inconsistent code in the three RTTs and material being released without the extra QA checking.

Lesson Learned #3

Do not discount the value of CM and QA. At a minimum, pay for the "best practices" of the vendor in CM and QA.

Observation #4

Given the opportunity, good people will make good decisions and deliver a useful product.

Discussion #4

In spite of numerous "changes," Reflectone held to the idea of delivering a useful product. Reputation did matter and they were working to achieve success. Unfortunately, they had to perform the work with a very limited staff and low priority so schedule was always an issue.

Lesson Learned #4

Recognize that there is a minimum viable staff to do a job and expect to pay for the support.

Observation #5

Long term maintenance and operations support planning is essential to control costs.

Discussion #5

Because the original program was simply to deliver the system without a funded support package or service, Government was constantly having to find funds to support operations and maintenance on an ad hoc basis. As a result, we were unable to achieve a consistent and long-term support arrangement, which could have lowered cost. Each deployment became an individual purchase order in response to changes in the basic DO. "Pride of ownership" was never really achieved because we never did make a single contractor responsible for operations and maintenance.

Lesson Learned #5

Plan for the operations and maintenance support and fund it.

6.2 Site Integration and Exercise support

Observation #1

Need to have pre-deployment site-survey coordination meetings with the unit to be trained.

Discussion #1

We discovered that sites were not always prepared to receive our trailer. We needed to coordinate routes in and out, parking places, power availability, and telephone communications support. We found the units eager to have the device available and they made special efforts to accommodate the system, nevertheless, it was necessary to make a survey prior to deployment.

Lesson Learned #1

Risk assessments and mitigation plans are not infallible but a physical inspection helps reduce risk.

Observation #2

Pre-deployment coordination of training plan is essential to success.

Discussion #2

When units were scheduled for specific tasking or deployments and were using the BICEP-TC as a train-up vehicle, they were more effective. The deployment objective focused the unit's attention and allowed the overall objective to become the collective task, not the fidelity of the vehicle simulation. The operations and training staffs that worked with the BICEP-TC crew before the deployment were able to tailor their expectation and thus the utilization plan to benefit of all parties. They were willing to spend some time going through an orientation period prior to jumping into the formal training session.

Lesson Learned #2

Units that took the time to plan their training and coordinate with the BICEP-TC crew were more successful.

7 Conclusion

The BICEP-TC approach has been extremely successful in supporting the collective task training objectives. It demonstrated a bold and innovative concept in acquisition and generally achieved the program objectives. Despite an under funded support concept and compressed schedules with budgetary constraints, the integration of the system with other simulations has been a success. The concepts helped to validate the AVCATT requirements and define fidelity issues for the user's and STRICOM.

8 Acronyms

AAR	After Action Review
ADST	Advanced Distributed Simulation Technology
ARMS	Aviation Recconfigurable Manned Simulator
ASTi	Advanced Simulation Technologies, Inc
AVTB	AViation Test Bed
BICEP	Battlespace Integrated Concept Emulation Program
CDRL	Contract Data Requirements List
CTDB	Compressed Terrain DataBase
DACS	Digital Audio Communication System
DIS	Distributed Interactive Simulation
DO	Delivery Order
DOTDS	Directorate for Training Doctrine and Simulation
GFE	Government Furnished Equipment

GFI	Government Furnished Information
HMD	Helmet-Mounted Display
LAN	Local Area Network
LMC	Lockheed Martin Corporation
MFAS	Mini-Feasibility Analysis Study
ModSAF	Modular Semi-Automated Forces
OTW	Out-The-Window
PC	Personal Computer
PDU	Protocol Data Unit
PoP	Proof of Principle
PVD	Plan View Display
RTT	Reconfigurable Tactical Trainers
SIGI	Silicon Graphics Industries
STRICOM	(US Army) Simulation Training and Instrumentation Command
TRADOC	TRAINing and DOcumentaion Command
UDO	Unilateral Delivery Order
USAAVNC	U. S. Army AViation Center
VV&A	Verification, Validation, and Accreditation