

**ADVANCED DISTRIBUTED
SIMULATION TECHNOLOGY II
(ADST II)
VIRTUAL INTEGRATION EXPERIMENT
(VIE)
DO#0040
CDRL AB01
FINAL REPORT**



FOR: NAWCTSD/STRICOM
12350 Research Parkway
Orlando, FL 32826-3224
N61339-96-D-0002
DI-MISC-80711

BY: Lockheed Martin Corporation
Martin Marietta Technologies, Inc.
Information Systems Company
12506 Lake Underhill Road
Orlando, FL 32825

UNCLASSIFIED

Approved for public release; distribution is unlimited

REPORT DOCUMENTATION PAGE*Form Approved*
OMB No. 074-0188

Public reporting burden for this collection of information is estimated to average 1 hour per response, including the time for reviewing instructions, searching existing data sources, gathering and maintaining the data needed, and completing and reviewing this collection of information. Send comments regarding this burden estimate or any other aspect of this collection of information, including suggestions for reducing this burden to Washington Headquarters Services, Directorate for Information Operations and Reports, 1215 Jefferson Davis Highway, Suite 1204, Arlington, VA 22202-4302, and to the Office of Management and Budget, Paperwork Reduction Project (0704-0188), Washington, DC 20503

1. AGENCY USE ONLY (Leave blank)

2. REPORT DATE

23 FEB 1998

3. REPORT TYPE AND DATES COVERED

final

4. TITLE AND SUBTITLE

Advanced Distributed Simulation Technology II (ADST-II)
Virtual Intergration Experiment (VIE) DO #0040 Final Report

5. FUNDING NUMBERS

N61339-96-D-0002

6. AUTHOR(S)

7. PERFORMING ORGANIZATION NAME(S) AND ADDRESS(ES)

Lockheed Martin Information Systems
ADST-II
P.O. Box 780217
Orlando FL 32878-02178. PERFORMING ORGANIZATION
REPORT NUMBER

ADST-II-CDRL-VIE-9800017

9. SPONSORING / MONITORING AGENCY NAME(S) AND ADDRESS(ES)

NAWCTSD/STRICOM
12350 Research Parkway
Orlando, FL 32328-322410. SPONSORING / MONITORING
AGENCY REPORT NUMBER

11. SUPPLEMENTARY NOTES

12a. DISTRIBUTION / AVAILABILITY STATEMENT

Approved for Public release; distribution is unlimited

12b. DISTRIBUTION CODE

13. ABSTRACT (*Maximum 200 Words*)

The purpose of this Final Report is to document the Advanced Distributed Simulation Technology II (ADST II) effort that supported the Virtual Integration Experiment (VIE). This report includes a full description of the experiment, a limited discussion of the experiment's configuration, its conditions and lessons learned. A more detailed "blue print" of the VIE system's architectural design is found in the Network Integration Plan produced as a separate document. This document does not address data analysis or the performance of the Combat Identification technologies

14. SUBJECT TERMS

STRICOM, ADST-II, VIE, simulation, , LWTB, MWTB, ACTD

15. NUMBER OF PAGES

32

16. PRICE CODE

17. SECURITY CLASSIFICATION
OF REPORT UNCLASSIFIED18. SECURITY CLASSIFICATION
OF THIS PAGE
UNCLASSIFIED19. SECURITY CLASSIFICATION
OF ABSTRACT UNCLASSIFIED

20. LIMITATION OF ABSTRACT

1. INTRODUCTION.....	2
1.1 Purpose.....	2
1.2 Contract Overview	2
1.3 Experiment Overview.....	2
1.4 Technical Overview	3
2. Applicable Documents.....	3
2.1 Government.....	3
2.2 Non-Government	3
3. System Description.....	4
3.1 System Configuration and Layout	4
3.1.1 System Configuration and Layout MWTB.....	4
3.1.2 System Configuration and Layout AVTB	7
3.2 Description of System Components.....	11
3.2.1 M1/M2 Manned Simulators.....	11
3.2.1.1 M1/M2 Manned Simulator BCIS	11
3.2.2 Voice Radios.....	11
3.2.3 Appliqué Operations	12
3.2.4 Appliqué Interface / Situational Awareness Tactical Internet Data Server (SATIDS).....	12
3.2.5 Rotary Wing Aircraft (RWA) Manned Simulators.....	12
3.2.5.1 RWA BCIS	12
3.2.5.2 RWA System Improvement Program Plus (SIP+).....	13
3.2.6 ModSAF Operations	13
3.2.6.1 ModSAF Enhancements	13
3.2.7 Enlisted Terminal Air Controller (ETAC).....	13
3.2.7.1 ETAC BCIS	14
3.2.7.2 ETAC Target Acquisition	14
3.2.7.3 ETAC SADL Forward Area Control (FAC).....	14
3.2.8 XCIAU	15

3.2.9 Personal Computer (PC) Sound System	15
3.2.10 Versatile Virtual Vehicle Simulator (VVVS)	15
3.2.11 Video Teleconference (VTC).....	15
3.2.12 Data Logger	15
3.2.12.1 Audio/Video Capture	16
3.2.13 Time Stamper.....	16
3.2.14 Stealth System.....	16
3.2.15 DIS LAN Network Configuration and Long Haul Network.....	17
3.3 Database and Scenario Development.....	17
4. Conduct of The Experiment	19
4.1 Troop Training	19
4.2 Pilot Test	19
4.3 Experiment and Trial Runs	19
5. Legacy	21
6. Observations and Lessons Learned	21
6.1 System Integration and Development.....	21
6.1.1 Integration Schedule	21
6.1.2 Visual Model Development	21
6.1.3 Long Haul	22
6.1.4 Communication Between Sites.....	23
6.1.5 SINCGARS Radio Emulator (SRE) and ASTi Radio Model.....	23
6.2 Administration	24
6.2.1 Data Collection Forms	24
6.2.2 Experiment Schedule	24
6.3 ModSAF.....	25
6.4 Hardware.....	25
6.4.1 Manned Simulators	25
7. Conclusion.....	25
8. Points of Contact.....	25

9. Acronym List 27

List of Figures

FIGURE 1 VIE ASSET LAYOUT AT MWTB	5
FIGURE 2 HARDWARE AND INTERFACE DIAGRAM AT MWTB	6
FIGURE 3 VIE ASSET LAYOUT AT AVTB	8
FIGURE 4 HARDWARE AND INTERFACE DIAGRAM AT AVTB	9

List of Tables

TABLE 1 ADST II MWTB ASSETS	7
TABLE 2 ADST II AVTB ASSETS	10
TABLE 3 VIE TRIALS MATRIX	20

Executive Summary

The Virtual Integration Experiment (VIE) was a multi-site exercise conducted at the following locations: the Mounted Warfare Test Bed (MWTB) at Fort Knox, KY; the Aviation Test Bed (AVTB) at Ft. Rucker, AL; and Armstrong Laboratories (AL) at Mesa, AZ. The exercise took place from 5 January to 21 January 1998 in support of the Combat Identification Advance Concepts Technology Demonstration (ACTD). The exercise was sponsored by the Project Manager (PM) for Combat Identification, Ft. Monmouth, NJ, and the U.S. Army Simulation, Training, and Instrumentation Command (STRICOM), Orlando, FL. The experiment utilized manned virtual simulators and semi-automated forces to support an Armored Cavalry Squadron, conducting five varying scenarios employing varying combat identification technologies. The scenarios were conducted on the National Training Center terrain database and included screen, zone reconnaissance, guard and movement to contact vignettes. The objectives of the effort were:

- 1) To investigate the effects on mission performance at squadron levels in a joint environment for a friendly vehicle identification system, and a supplemental digital Situational Awareness (SA) system.
- 2) To investigate the effects of an interrogation and response combat identification system on fratricide occurrence and gunnery performance.
- 3) To investigate the effects of a supplemental combat identification system on the timeliness and accuracy of a digitized local battlefield information and the impact of increased network loading on the Tactical Internet.

The experiment had a secondary objective of serving as a training opportunity for an Armored Cavalry Squadron.

The experiment was conducted over a period of three weeks. The baseline configuration consisted of voice only with the Appliqué Command & Control (C2) system providing SA. Subsequent trials followed by adding various combat identification technologies in an effort to explore the contribution of each system. A total of 16 runs were conducted.

This Final Report addresses the simulation systems interconnected, the integration of Government Furnished software models, and the lessons learned in support of the experiment. Development of the software modifications to Modular Semi-Automated Forces (ModSAF), and the initial integration of other software models, was conducted at the Operational Support Facility (OSF) in Orlando, FL. These software developments were then integrated into the Mounted Warfare Test Bed and the Aviation Test Bed for support of the experiment. This Final Report does not address data analysis or the performance of the Combat Identification technologies.

1. INTRODUCTION

1.1 *Purpose*

The purpose of this Final Report is to document the Advanced Distributed Simulation Technology II (ADST II) effort that supported the Virtual Integration Experiment (VIE). This report includes a full description of the experiment, a limited discussion of the experiment's configuration, its conditions and lessons learned. A more detailed "blue print" of the VIE system's architectural design is found in the Network Integration Plan produced as a separate document. This document does not address data analysis or the performance of the Combat Identification technologies.

1.2 *Contract Overview*

The Virtual Integration Experiment was performed as Delivery Order (DO) #0040 under the Lockheed Martin ADST II contract with the U.S. Army Simulation Training and Instrumentation Command (STRICOM).

1.3 *Experiment Overview.*

The purpose of the VIE was to use man-in-the loop simulators and simulated forces to evaluate the effect of combat identification systems on ground, rotary wing, and fixed wing combat vehicles supporting an Armored Cavalry Squadron in a joint task force. Data was collected to capture soldier responses to survivability events and the command and battle staff's ability to use the additional experimental digital information to improve their battlefield performance. The experiment was designed to explore: operational effectiveness; tactics, techniques, and procedures (TTPs); soldier-machine interfaces; training; and input parameters for constructive modeling. The experiment employed eight M1, two M2, six OH-58D, one A-10, and two F-16 manned simulators. Modular Semi-Automated Forces (ModSAF) rounded out the force by providing additional platoons of Blue Forces, along with a manned a Tactical Operations Center simulator, to create a simulated Armor Cavalry Squadron. The Blue Force conducted tactical operations against a doctrinally depicted opposing ModSAF threat force.

1.4 Technical Overview

The technical approach to the Virtual Integration Experiment involved the integration of: Appliqué into the ground manned simulators; Battlefield Combat Identification System (BCIS) algorithms into the M1, M2, and Rotary Wing Aircraft (RWA) manned simulators; BCIS and fratricide algorithms into ModSAF; and the newly developed Situational Awareness Tactical Internet Data Server (SATIDS) software. SATIDS modeled the Tactical Internet communication delays while providing the Distributed Interactive Simulation (DIS) and Appliqué interface. Manned simulators, ModSAF and SATIDS software changes have been documented in their respective Version Description Documents (VDDs). Software changes were initially developed at the Operational Support Facility (OSF) during the test and development portion of the delivery order. An integration period then followed at the Mounted Warfare Test Bed (MWTB), and the Aviation Test Bed (AVTB) which concluded with a Test Readiness Review briefing held after the Pilot Trials were completed. The experiment period lasted three weeks during which 16 different iterations were run using five basic scenarios.

There were two planned Long Haul Tests prior to the Virtual Integration Experiment. The Long Haul Tests were executed to identify any potential problems with DIS Enumeration consistency among the sites, and to identify any network loading issues. The Lead VIE Site Systems Engineer coordinated all integration activities.

Software development, integration and test issues related to Armstrong Laboratories are documented in the Armstrong Laboratories VIE Final Report.

2. Applicable Documents

2.1 Government

-ADST II Work Statement for the Virtual Integration Experiment, 24 May 1996, AMSTI-96-WO39, Version 2.0

-ADST II Network Integration Plan for the Virtual Integration Experiment, 24 May 1996, AMSTI-96-WO39, Version 2.0

-Battle Lab Experiment Plan (BLEP) for Virtual Integration Experiment, ATZK-MW, Fort Knox, KY, 24 April 1966

2.2 Non-Government

-ADST II Technical Approach for the Virtual Integration Experiment, 30 April 1996, ADST II-TAPP-018R-9600048B

- ADST II CDRL AB04, Force Protection Experiment III (FPE III) VDD, 15 January, 1997, ADST-II-CDRL-018R-9600425

3. System Description

3.1 System Configuration and Layout

The MWTB and AVTB contain vehicle simulators, networks, Semi-Automated Forces (SAF) capabilities, battlefield monitoring displays, and data collection and analysis tools.

3.1.1 System Configuration and Layout MWTB

The Mounted Warfare Test Bed at Fort Knox, KY, contained a variety of vehicle simulators, networks, Semi-Automated Forces (SAF) capabilities, displays for monitoring the battlefield, utilities to facilitate execution of exercises, automated data collection capabilities, and a data reduction and analysis subsystem. The MWTB simulation and support platform layout used for the Virtual Integration Experiment is depicted in Figure 1.

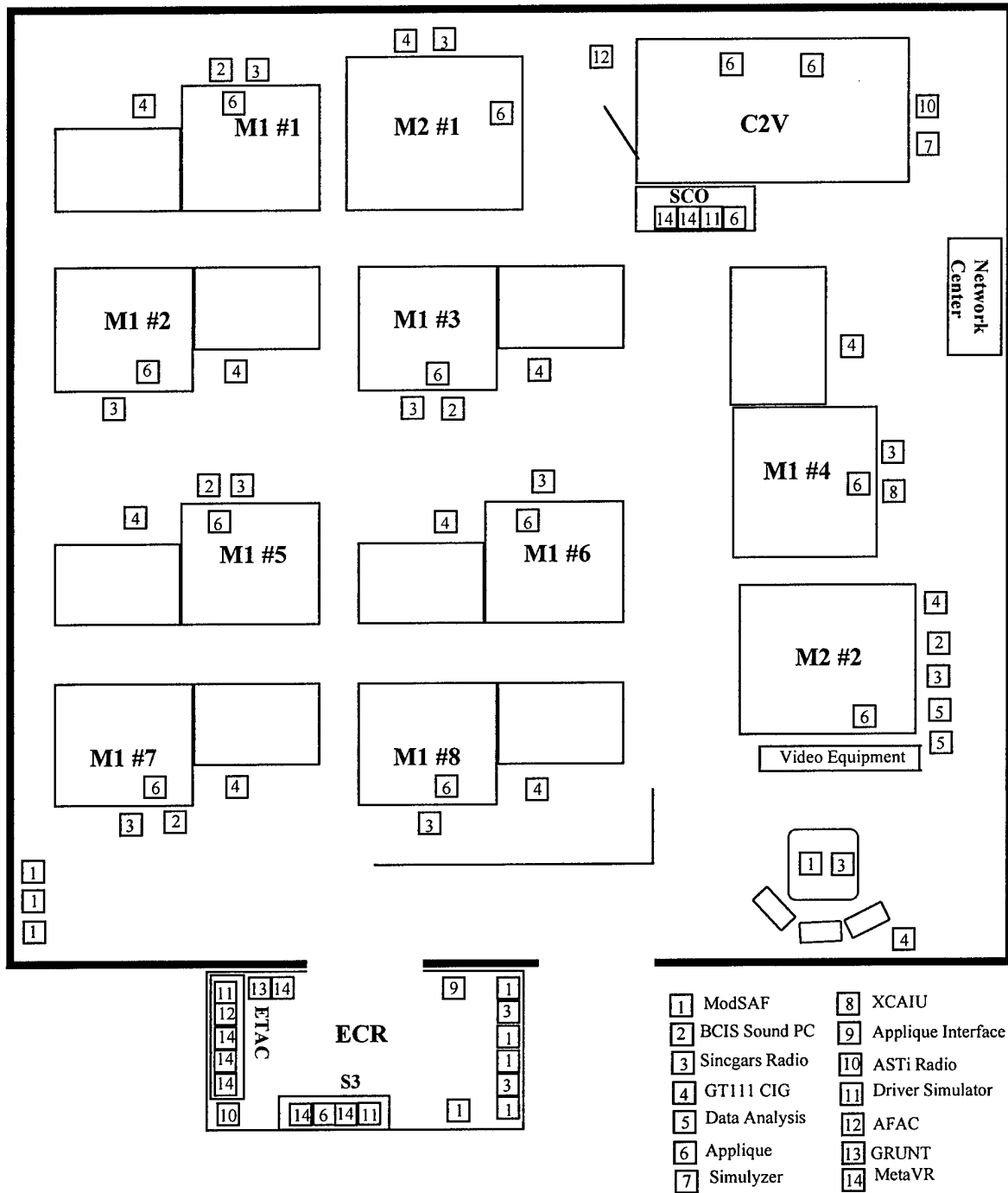

Figure 1 VIE Asset Layout at MWTB

Figure 2 depicts the MWTB Hardware and Network Interface diagram. The experiment was conducted using simulation assets interconnected on Ethernet Local Area Networks (LANs) via thin net cable. The network was also connected to the Defense Simulation Internet (DSI) for the Long Haul connection to other sites.

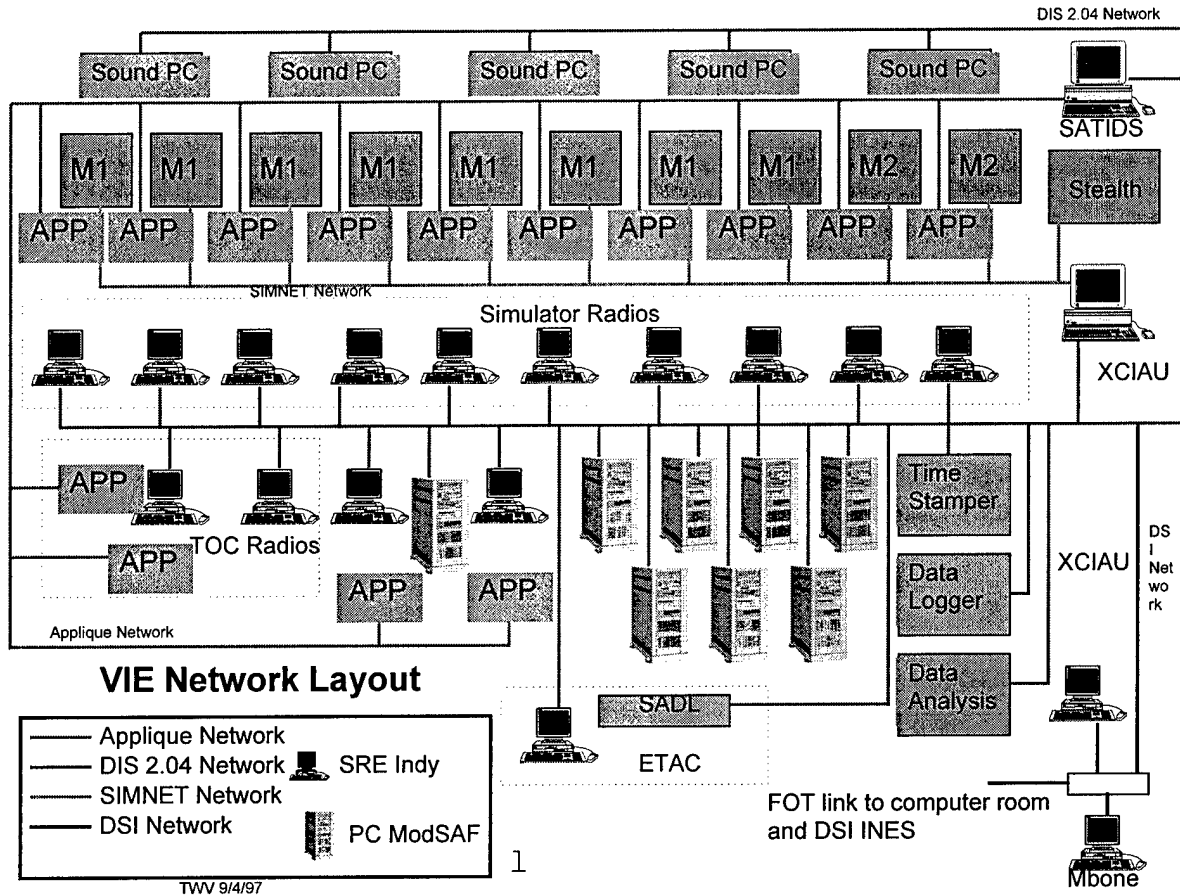

Figure 2 Hardware and Interface Diagram at MWTB

Table 1 lists the MWTB assets used for VIE, their purpose, and their protocol in support of the experiment. For this experiment, DIS 2.04 was used.

Table 1 ADST II MWTB Assets

ADST II ASSET	#	PURPOSE	PROTOCOL
Modified M1 simulator	8	Manned M1 Simulator	SIMNET
Modified M2 simulator	2	Manned M2 Simulator	SIMNET
Stealth (Role Player - RP)	1	Battlefield Display	SIMNET
ModSAF Workstations (RP)	9	Semi-Automated Forces	DIS
SINCGARS Radio Emulators (SREs)	13	Radio Communication	DIS
XCIAU	1	SIMNET to DIS Translator	SIMNET/DIS
Data Loggers	1	Record DIS PDUs	DIS
DIS Time Stamper	1	Time Stamp	DIS
FO/FAC	1	9 Line Digital Message Transmitter	DIS
ASTi	2	Radio Communication	DIS
MetaVR	8	Visual System	DIS
TASC Driver Simulator	3	M2 Simulator	DIS
SADL FAC	2	Situational Awareness Display	DIS
SATIDS	1	Appliqué Simulation Server	DIS/VMF
PC Sound System	5	BCIS Sound	DIS
Appliqué	14	Situational Awareness Display	VMF

3.1.2 System Configuration and Layout AVTB

The Aviation Test Bed at Fort Rucker, AL, contained a variety of vehicle simulators, networks, Semi-Automated Forces (SAF) capabilities, displays for monitoring the battlefield, utilities to facilitate execution of exercises, automated data collection capabilities, and a data reduction and analysis subsystem. The AVTB simulation and support platform layout used for the Virtual Integration Experiment is depicted in Figure 3.

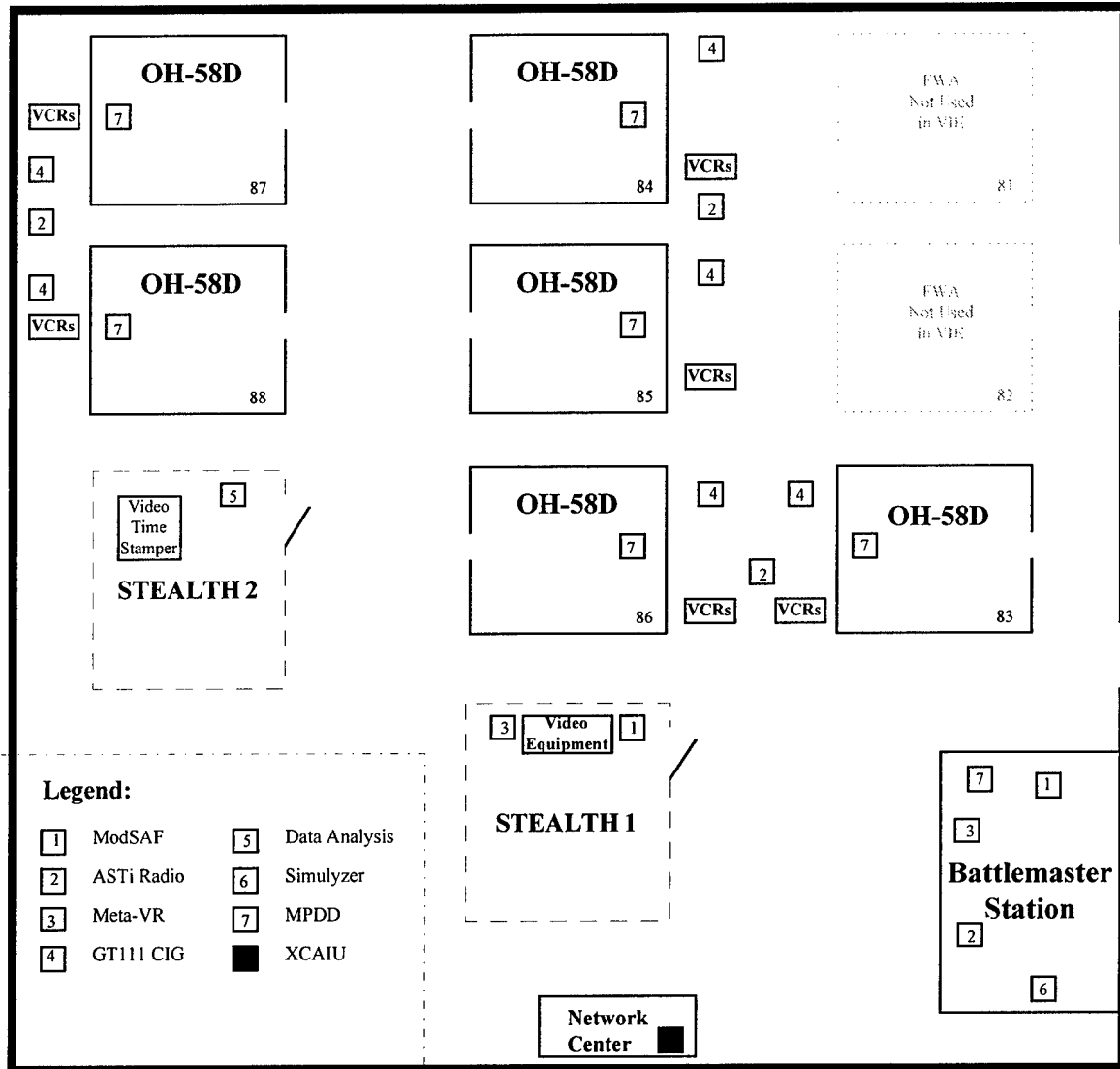
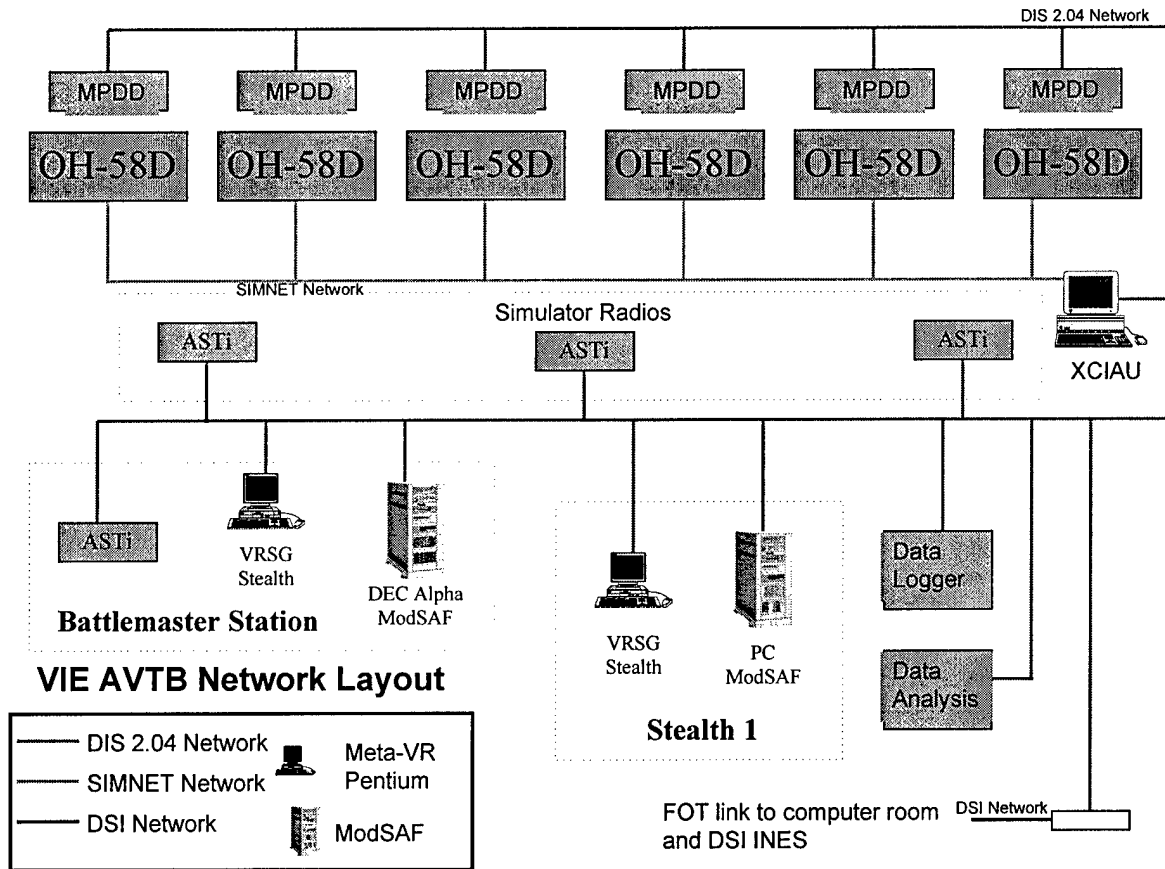

Figure 3 VIE Asset Layout at AVTB

Figure 4 depicts the AVTB Hardware and Network Interface diagram. The experiment was conducted using simulation assets interconnected on Ethernet LANs via thin net cable. The network was also connected to the Defense Simulation Internet (DSI) via the Fiber Optic Terminal (FOT) link for the Long Haul connection to other sites.



JQP3 1/29/98

Figure 4 Hardware and Interface Diagram at AVTB

Table 2 list the AVTB assets used for VIE, their purpose, and their protocol in support of the experiment. For this experiment, DIS 2.04 was used.

ADST II ASSET	#	PURPOSE	PROTOCOL
Modified OH-58D simulator	6	Manned OH-58D Simulator	SIMNET
MetaVR Stealth (RP)	1	Battlefield Display	DIS
XCIAU	1	SIMNET to DIS Translator	SIMNET/DIS
Data Loggers	1	Record DIS PDUs	DIS
Time Stamper	1	Time Stamp	DIS
Multiple Purpose Digital Display (MPDD)	6	Situational Awareness Tool	DIS
ASTi	4	Radio Communication	DIS

Table 2 ADST II AVTB Assets

3.2 Description of System Components

This section describes the functionality and operation of the system components, which include the Government Furnished Equipment (GFE), models, and their integration into the hardware at the MWTB and AVTB.

3.2.1 M1/M2 Manned Simulators

The MWTB provided eight M1 and two M2 manned simulators on a SIMNET LAN for the Virtual Integration Experiment. The simulators were manned by tank platoon leaders and troop commanders as part of an Armored Cavalry Squadron. The subsystems communicated to the DIS network via the Translator Cell Interface/Adapter Unit (XCIAU) translator. Each manned simulator was equipped with an Appliqué laptop device to provide Situational Awareness data.

3.2.1.1 M1/M2 Manned Simulator BCIS

The ground BCIS System provided the operator with the ability to interrogate a target and positively identify it as a friendly. The operator interrogates a potential target coincident with activation of the laser range finder. When the interrogation is made, an "Intent To Shoot" (ITS) message is generated with the target's location. The waveform is transmitted in a cone shape within the simulated environment. If a friendly target replies with a "Don't Shoot Me" (DSM) message with a location that correlates with the ITS location, a red "FRIEND" indicator flashes on the site and "FRIEND" is heard through the vehicle headset. If a friendly target replies with a DSM message that does not correlate with the ITS location but is within a predefined distance from the ITS location, the red "FRIEND" indicator flashes and "FRIENDLY AT RANGE" is heard through the headset. If the interrogated target is not positively identified as friendly, nothing is displayed on the operator site, and "UNKNOWN" is heard through the vehicle headset. The Ground-to-Ground BCIS operation for VIE was simulated entirely within the RWA Manned simulator software.

The M1 and M2 simulators operated on a GT-111 system with 14 Megabytes (MB) of Random Access Memory (RAM) and a 380MB hard drive, and was loaded with GTOS 8.21 operating system and simulator software versions VIE M1 1.0 and VIE M2 1.0.

3.2.2 Voice Radios

The voice communication networks for the VIE were implemented using a combination of radio models. The Advanced Simulation Technology Inc. (ASTi) voice communications system was used at the AVTB and Armstrong Labs. The MWTB used the Single Channel Ground and Airborne Radio System (SINCGARS) Radio Emulator (SRE) and the ASTi Radio Model. The ASTi radio model was capable of transmitting and receiving DIS Protocol Data Units (PDUs), and was connected to each respective DIS LAN for data transfer over the DSI network. The ASTi system was programmed with entity information for each voice PDU. This information was used to determine the signal-to-noise ratio for incoming messages, and by a spherical earth model for determining Line of Sight (LOS) limitations. The MWTB, AVTB, and AL maintain joint responsibility for successful integration and compatibility of the voice communications systems.

The SRE operated on a SGI Indy system with 64MB of RAM and a 1GB hard drive, and was loaded with the IRIX 6.2 operating system and SRE software version 4.1.

The ASTi radio system operated on a Personal Computer (PC) Pentium system with 64MB of RAM and a 1.6GB hard drive, and was loaded with the DOS 6.22 operating system and ASTi software version 3.10d.

3.2.3 Appliqué Operations

The Appliqué Command and Control Tactical Display was provided as GFE. The Appliqué display was mounted to the right of the tank commander in the M1 and M2 manned simulators. Appliqué provides situational awareness by displaying locations of Blue Force units on a continuously updated map.

Appliqué operated on a Compaq Elite Laptop Computer with 64MB of RAM and a 1.3GB hard drive, and was loaded with the Santa Cruz Operations (SCO) UNIX operating system and Appliqué software version 1.02a.

3.2.4 Appliqué Interface / Situational Awareness Tactical Internet Data Server (SATIDS)

SATIDS is a real-time DIS simulation that models realistic SA dissemination via the Army's Tactical Internet (TI). The SA data consists primarily of vehicle position reports. SATIDS models the Tactical Internet (TI) and bridges the simulated environment and real Command and Control (C2) devices like Appliqués. The modeling includes the delays associated with messages routing through the TI, as well as radio linkage/propagation effects. The SATIDS receives Distributed Interactive Simulation (DIS) Entity State PDUs from the manned simulators and ModSAF. This information is used to model the interactions of the entities' SA data. The server understands that real Appliqués are on the network and sends them VMF messages. SATIDS provides a way for entities and applications in the DIS environment to send their positions to Appliqués.

The SATIDS operated on a dual ported Sun Sparc20 system with 64MB of RAM and a 1GB hard drive, and was loaded with the SunOS 5.5.1 operating system and SATIDS software version 1.02a.

3.2.5 Rotary Wing Aircraft (RWA) Manned Simulators

The AVTB provided six OH-58D RWA simulators for the Virtual Integration Experiment. These simulators represented two helicopter air troops as part of an Armored Cavalry Squadron. The subsystems communicate to the DIS network via the XCIAU translator.

The RWA operated on a GT111 system with 14MB of RAM and a 380MB hard drive, and was loaded with the GTOS 8.21 operating system and simulator software versions VIE RWA 1.0.

3.2.5.1 RWA BCIS

The Air-to-Ground BCIS provides the operator with an ability to interrogate a target and positively identify it as a friendly. The operator interrogates a potential target coincident with activation of the laser range finder. The BCIS interrogation can be performed with the laser in

“off,” “on” and “standby” modes. When the interrogation is made, an “Intent To Shoot” (ITS) message is generated with the target’s location. The interrogation waveform is transmitted in the shape of a cone in the simulated environment. If a friendly target replies with a “Don’t Shoot Me” (DSM) message with a location that correlates with the ITS location, a “FRIENDLY” response occurs on the operator’s FLIR view. If a friendly target replies with a DSM message that does not correlate with the ITS location but is within a predefined distance from the ITS location, a “FRIENDLY @” response occurs on the operator’s FLIR view. If the interrogated target is not positively identified as friendly, an “UNKNOWN” response occurs on the operator’s FLIR view. The Air-to-Ground BCIS operation for VIE was simulated entirely within the RWA Manned simulator software.

3.2.5.2 RWA System Improvement Program Plus (SIP+)

The RWA Combat ID mode using SINCGARS SIP+ was simulated by the RWA pilot acquiring and lasing the target. The simulated SIP+ “steals” the first 3 SINCGARS SIP+ frequency hops to interrogate all vehicles within the SIP+ “footprint”. Then the SIP+-equipped vehicles within the footprint respond to the interrogation to let the RWA know if any friendly vehicles are within the footprint. The real Air-to-Ground SINCGARS SIP+ Combat ID system uses Very-High Frequency (VHF) signals to identify SIP+ equipped friendly ground platforms beyond visual range and presents a “FRIENDLY” or “UNKNOWN” response on the gunner’s FLIR view. The SINCGARS SIP+ operation was simulated entirely within the RWA Manned simulator software.

3.2.6 ModSAF Operations

ModSAF was used for the Virtual Integration Experiment. ModSAF was used for Blue and Red Forces. The Blue Forces provided the additional platoons required to fill-out the Armored Cavalry Squadron. Red Forces were provided in a configuration of a Motorized Rifle Battalion to complete the scenario requirements. The ModSAF entities were generated from the MWTB.

ModSAF operated on a Pentium Pro system with 128MB of RAM and a 4GB hard drive, and was loaded with the LINUX operating system and ModSAF software version VIE 1.0 (based on ModSAF 3.0).

3.2.6.1 ModSAF Enhancements

ModSAF was enhanced and modified in the Virtual Integration Experiment to meet specific requirements. A library, “Lib Appliqué,” was added to send Data PDUs to the SATIDS. The data PDUs were used to provide the ModSAF entities’ positions to the Appliqué systems. BCIS and Fratricide algorithms were also added to the ModSAF baseline. New munitions and damage tables were added to support the Army Material Systems Analysis Activity (AMSAA) classified data. The ModSAF VIE 1.0 VDD discusses the ModSAF changes in detail.

3.2.7 Enlisted Terminal Air Controller (ETAC)

An ETAC vehicle was provided to allow for an on the battlefield view for the enlisted aerial observer. The ETAC was located forward with one of the maneuver troops to plan and conduct Close Air Support (CAS) missions. The ETAC vehicle was simulated on the battlefield as a DIS entity by using the PC-based Virtual Versatile Vehicle Simulator (VVV). The ETAC vehicle was driven around the battlefield using a set of PC driver controls. The out-the-window view of

the battlefield was simulated using the MetaVR Stealth. The ETAC simulator was located at the MWTB.

3.2.7.1 ETAC BCIS

The ETAC BCIS system was simulated by allowing the operator to interrogate a target on the battlefield using the MetaVR Stealth. BCIS situational awareness data was returned and used to fill out a 9-line digitized message. The 9-line digitized message was sent from the Grunt, a hand held computer, to the Fixed Wing Aircraft (FWA) simulator after target acquisition was performed.

The Grunt operated on a Texas Micro system with 16MB of RAM and a 248MB hard drive, and was loaded with the Windows95 operating system and Grunt software version VIE Grunt 1.0.

3.2.7.2 ETAC Target Acquisition

The ETAC operator performed target acquisition using a Mini Eyesafe Laser Infrared Observation Set (MELIOS) that performed an automatic hand-off of target coordinates to the 9 line-message. The ETAC operator added any additional information needed by the FWA pilot and then sent the 9-line digitized message to the FWA aircraft. The 9-line message was sent across the DSI Network to Armstrong Labs via a Signal PDU. Armstrong Labs aircraft outfitted with a simulated Situational Data Link (SADL) system received the data from the 9-line message and displayed the data, which was used for target acquisition.

3.2.7.3 ETAC SADL Forward Area Control (FAC)

The ETAC SADL FAC contains the same functionality as described in 3.2.7.1 and 3.2.7.2 and in addition is outfitted with a SADL display containing Situational Awareness and targeting data. This data was sent across the DSI Network from Armstrong Labs via a Signal PDU, and is the same data displayed by the SADL display in the SADL-equipped Fixed Wing Aircraft.

The SADL FAC operated on a Micron system with 32MB of RAM and a 1.2GB hard drive, and was loaded with the Windows95 Operating System and SADL FAC software version VIE SADL FAC 1.0.

3.2.8 XCIAU

The Translator Cell Interface/Adapter Unit (XCIAU) is a bi-directional protocol translator between SIMNET and DIS 2.04. The VIE experiment used a pre-released XCIAU (version 4.7) from the ADST II Synthetic Theater Of War (STOW) program. This version of the XCIAU was enhanced to translate the SIMNET Event PDU to the DIS 2.04 Data PDU. The SIMNET Event PDU was used to record BCIS queries, then translated to DIS for the purposes of data collection and the generation of an audio message ("friend" or "unknown") indicating BCIS status of the queried vehicle. The audio was generated via a PC-based sound generation system developed by TASC.

The XCIAU operated on an Indigo2 system with 128MB of RAM and a 2GB hard drive, and was loaded with the IRIX 5.3 operating system and XCIAU software version STOW XCIAU 4.7.

3.2.9 Personal Computer (PC) Sound System

There were five PC Sound Systems located at the MWTB which were used to provide BCIS sound. The PC Sound System used the DIS Event PDU to generate an audio message, "friend" or "unknown," indicating the BCIS status of the queried vehicle. This system was developed by TASC.

The PC Sound System operated on a Micron system with 32MB of RAM and a 1.2GB hard drive, and was loaded with the Windows95 operating system and PC Sound System software version VIE 1.0.

3.2.10 Versatile Virtual Vehicle Simulator (VVVS)

There were three TASC VVVS systems located at the MWTB which were used to provide the Squadron Commander, S3, and ETAC the capability to move around the battlefield. The VVVS provided the motion dynamics model, and MetaVR systems provided the out-the-window 3D view. These vehicles were DIS entities that could shoot and do BCIS queries.

The VVVS operated on a Micron Pentium Pro system with 32MB of RAM and a 1.2GB hard drive, and was loaded with the Windows95 Operating System and VVVS software version VIE VVV 1.0.

The MetaVR operated on a Pentium II system with 64MB of RAM and a 1.2GB hard drive, and was loaded with the Windows95 Operating System and MetaVR software version 2.1b.

3.2.11 Video Teleconference (VTC)

A Video Teleconference system between the MWTB and AVTB was provided by using the Communications and Electronics Command's (CECOM's) Army Interoperability Network (AIN). This effort was coordinated through the CECOM representative located at Ft. Knox.

3.2.12 Data Logger

The Data Logger is an ADST II asset that captures the network traffic and places the data packets on a disk or tape file. The Data Logger performs the following functions:

- a. Packet Recording - Receives packets from the DIS network, time stamps and then writes to a disk or tape.
- b. Packet Playback - Packets from a recorded exercise can be transmitted in real time or faster than real time. The Data Logger can also suspend playback (freeze time) and skip backward or forward to a designated point in time. The logger can be controlled directly from the keyboard or remotely from the PVD. Playback is visible to any device on the network (PVD, Stealth Vehicle, a vehicle simulator, etc.).
- c. Copying or Converting - Files are copied to another file, which can be on the same or a different medium; and files from the older version of the Data Logger can be converted to a format compatible with the current version of the Data Logger.

For the Virtual Integration Experiment, one data logger was employed at the MWTB to capture the exercise on the DIS network. The data logger was used to capture the standard output data for analysis. The logger ran on a Sun IPX system with 48 MB of RAM and a 1 GB Hard drive, and utilized the Sun OS 4.1.3 operating system.

3.2.12.1 Audio/Video Capture

The Fort Knox Television Lab installed through-the-sight video and audio connections (through the intercom) in eight manned simulators to capture audio and visual data for every trial run to be used in data collection. This footage was reduced by the Research Assistants, plugged into the data logger for a time line, and then turned over to the customer for further analysis.

The AVTB installed through-the-sight video in the six manned simulators to capture visual data for every trial run to be used in data collection. This footage was reduced by the Research Assistants, plugged into the data logger for a time line, and then turned over to the customer for further analysis.

3.2.13 Time Stamper

The time stamper is an ADST II asset consisting of a video time code generator, which produces a time and date (month/hour/min/sec) format, from an IBM-compatible Personal Computer (PC). The PC was programmed to read the video time code, convert the time data, and then generate a Time PDU. This Time PDU was issued on the DIS network each second. This provided the real world clock time on the logged data, which assisted in subsequent analyses.

The Time Stamper operated on a 286 PC system with 1MB of RAM and a 500MB hard drive, and was loaded with the Disk Operating System (DOS).

3.2.14 Stealth System

The Stealth gives the Observer/Controller (O/C) personnel a "window" into the virtual battlefield, allowing them to make covert observations of the action occurring during the scenario. In addition, through the use of the data logger, the Stealth gives observers and analysts an After Action Review (AAR) capability. The Stealth is a visual display platform that consists of a Plan View Display (PVD) map view (2D), various input devices, and three video displays that provide the operator with a panoramic view of the battlefield. The SIMNET Stealth was used at the MWTB. The MetaVR stealth was used at the AVTB.

The Stealth permits the controller to fly around the virtual battlefield and view the simulation without interfering with the action. The features of the Stealth allow the observer to survey the virtual battlefield from a variety of different perspectives, including:

- a. Tethered View - Allows the user to attach unnoticed to any vehicle on the virtual battlefield. The Executive Officer was always tethered to his ModSAF vehicle.
- b. Mimic View - Places the user in any vehicle on the virtual battlefield and provides the same view as the vehicle commander.
- c. Orbit View - Allows the operator to remain attached to any vehicle on the virtual battlefield and to rotate 360° about that vehicle, while still maintaining the vehicle as a center point of view.
- d. Free Fly Mode - Permits independent 3-D movement anywhere in the virtual battlefield.

The Stealth operated on a GT-111 system with 12MB of RAM and a 380MB hard drive, and was loaded with GTOS 4.7 operating system.

The PVD operated on a SGI Indy system with 96MB of RAM and a 380MB hard drive, and was loaded with IRIX 5.2 operating system.

3.2.15 DIS LAN Network Configuration and Long Haul Network

The Defense Simulation Internet (DSI) was the backbone for the Long Haul Network. The DSI was managed by the Defense Information Systems Agency (DISA) and Houston Associates, with the MWTB and AVTB connections funded by STRICOM. A standard DIS LAN configuration was used with Ten Base T/AUI cable. Standard Internet Protocol (IP) was used with the Class C addressing scheme. Test of the long haul was split into two efforts to incrementally test the system at levels of ascending complexity.

The first test verified:

- a) Long haul connectivity,
- b) Model identification (entity type)
- c) Visual database entity correlation (xyz location),
- d) Radio communication

The second long haul verified the operation of new software for M1, M2, and RWA SIMNET simulators, ModSAF, and SADL FAC.

3.3 Database and Scenario Development

The existing ADST II National Training Center terrain database was used to support the experiment. The database was 50 Km by 50 Km and used with daylight and no weather conditions.

A series of five test scenarios were developed in support of VIE. Each scenario contained four vignettes that depicted a Division Calvary Squadron conducting a deliberate attack, defense and

movement to contact operations. The scenarios included Operations Orders (OPORDS), Fragmentary Orders (FRAGOs) and overlays to support the mission. The orders and overlays were developed by personnel at the Mounted Battlespace Battle Lab (MBBL) and MWTB.

4. Conduct of The Experiment

4.1 Troop Training

Troop training was conducted over a three day period culminating in a full scale pilot test. The troop training was conducted at MWTB and AVTB from January 6 to January 8, 1998. Subject Matter Experts (SMEs) from TRW and CECOM provided classroom and hands-on training on Appliqué, BCIS and the ETAC Suite. This training was complemented by the MWTB's and AVTB's familiarization and orientation training on simulator operation.

4.2 Pilot Test

The Pilot Test was conducted from January 8 to January 9, 1998. During these two days, soldiers used the skills acquired in troop training to conduct tactical operations in a specially designed scenario. This scenario was designed to stress the systems and the soldier's skills.

Following the Pilot Test, the Test Readiness Review was held to discuss the problems, solutions, and status of the system. The customers approved the concept, and the contractor obtained permission to proceed with the experiment.

4.3 Experiment and Trial Runs

The trial runs for the experiment began January 12 and ended January 21, 1998. A total of 16 runs were conducted. The trials were executed running the six scenarios with their four vignettes. The system configuration was altered in a random order to detect the incremental contribution of each system. The configurations for the experiment included Baseline (Appliqué), Appliqué/BCIS, and ETACscenarios).

At the conclusion of the experiment, 16 trials were completed. Analysis of the experiment data was conducted by PM Combat ID (CI). This data was screened daily by MWTB and then turned over to PM CI for further analysis.

Table 3 defines the system configuration and scenario used in each trial.

DATE	Trial#	CASE	ROE	Operation	GND-GND	RWA	FWA	ETAC	PRIORITY /THREAT	TERRAIN BOX
1	2	3	4	5	6	7	8	9	10	11
8 Jan	Pilot	TI 1/R	R	Screen 1	BCIS	RW BCIS	SADL	SIP+ FAC	1/M	South E to W
9 Jan	1	SA 1	P	Screen 2	Appliqué	SIP+	SADL	SADL FAC	1/H	South E to W
	2	BL 1	R	Screen 3	Appliqué	Voice	Voice	Voice	1/H	South W to E
12 Jan	3	SA 2	R	MTC 1	Appliqué	SIP+	SADL	SADL FAC	1/L	Central E to W
	4	TI 2	R	MTC 2	BCIS	RW BCIS	SADL	SIP+ FAC	1/H	Central E to W
13 Jan	5	SA 3	P	MTC 3	Appliqué	SIP+	SADL	SADL FAC	1/H	Central E to W
	6	TI 3	P	MTC 4	BCIS	RW BCIS	SADL	SIP+ FAC	1/L	Central W to E
14 Jan	7	SA 4	R	Zone Recon 1	Appliqué	SIP+	SADL	SADL FAC	1/L	South E to W
	8	TI 4	R	Zone Screen 1	BCIS	RW BCIS	SADL	SIP+ FAC	1/H	South E to W
15 Jan	9	TI 5	P	Zone Recon 2	BCIS	RW BCIS	SADL	SIP+ FAC	1/H	South E to W
	10	SA 5	P	Zone Screen 2	Appliqué	SIP+	SADL	SADL FAC	1/M	South E to W
16 Jan	11	TI 6	P	Guard 1	BCIS	RW BCIS	SADL	SIP+ FAC	1/M	Central Orient W
	12	SA 6	R	Guard 2	Appliqué	SIP+	SADL	SADL FAC	1/H	Central Orient W
20 Jan	12 ¹	SA 6	R	Guard 2	Appliqué	SIP+	SADL	SADL FAC	1/H	Central Orient W
	13	SA 7	P	Guard 3	Appliqué	SIP+	SADL	SADL FAC	1/M	Central E to W
21 Jan	14	BL 2	P	Mov Guard	Appliqué	Voice	IDM	ATHS Only	2/H	Central E to W
	15 ²	TI 7	P	Mov Guard	BCIS	RW BCIS	SADL	SIP+ FAC	1/H	Central E to W

Table 3 VIE Trials Matrix

¹ Due to electrical malfunctions in the Mounted Warfare Test Bed, this trial was delayed and carried over from 16 January to 21 January. The electrical problem, a faulty circuit breaker, was fixed on 20 January. The loss of power resulted in the loss of one day of operations and three projected trials.

² Trial 15 was viewed remotely at the Army Simulation Center at the Pentagon.

5. Legacy

The legacy of the VIE is in the software modifications made to represent the Combat ID technologies, new visual models to support their effects, ModSAF development, and the integration of the varying simulations. Copies of the following software modifications are available from the ADST II Library:

- a. ModSAF VIE 1.0
- b. M1 VIE 1.0
- c. M2 VIE 1.0
- d. RWA VIE 1.0
- e. TASC SADL FAC
- f. TASC Virtual Vehicle Simulator
- g. SATIDS 1.0
- h. STOW XCAU 4.7

Version Description Documents (VDD) are available for ModSAF, XCIAU, M1, and M2 reflecting the modifications.

6. Observations and Lessons Learned

6.1 System Integration and Development

6.1.1 Integration Schedule

- **Observation**

Scheduling conflicts at the sites delayed final integration.

- **Discussion**

Even though there was adequate time for integration, there were delays at the MWTB because other experiments were using equipment required for VIE. There were many last minute changes requested by the customer.

- **Lesson Learned**

Integration must be completed prior to pilot training. LMC and STRICOM need to improve the coordination of equipment scheduling impacts due to multiple concurrent delivery orders. The customer needs to be briefed on schedule impacts due to additional requirements.

6.1.2 Visual Model Development

- **Observation**

Initial integration of the visual models into the manned simulators caused numerous visual problems.

- **Discussion**

The initial Dynamic Entity Database (DED) file used for VIE was developed for the Joint Combat Search and Rescue (JCSAR) program. This created problems because the vehicle mapping file associated with the JCSAR DED did not work with the baseline SIMNET executable. Eventually we created a new executable and a new DED file that worked together. A new DED file was needed because all visual models from the model list had to have the same color brown. We also modified the vehicle mapping file for the destroyed state visual model of certain vehicles.

- **Lesson Learned**

Work with the customer in identifying the model list up front. Early delivery of the new visual models with an in-depth description of the associated guise numbers is necessary to incorporate the information into the vehicle mapping file and the ammunition mapping file.

6.1.3 Long Haul

- **Observation**

Long Haul requires precise coordination with DISA and all participants before and during all exercises and test.

- **Discussion**

During both Long Haul tests for VIE, the Defense Simulation Internet (DSI), which provides the Long Haul network linkage, was in the process of transitioning from Houston Associates to the Defense Information Systems Agency (DISA). This created several configuration problems with DSI hardware and software among the three sites. The network went down several times each day during integration for various reasons. The following is a list of some of the causes:

- a) Necessity of repeatedly resetting the classified Improved Network Encryption System (INES), Aggregators, and long haul site routers.
- b) Wrong date set in the long haul site routers.
- c) Wrong router configuration at network control points (change with no apparent reason).
- d) Some part or all of the network was seemingly arbitrarily taken down for maintenance and test without notice.
- e) Key disk taken out of master network INES by Houston Associates in Arlington for no apparent reason.
- f) DISA took the master INES down for maintenance while we were trying to get the network up to prepare for the experiment 2 days before scheduled start of long haul portion of the experiment.
- g) Many instances where the reason was never found.

VIE was a classified experiment, thus necessitating the use of the INES encryption device. This device requires a key and a software disk that is provided by DSI via Post Security. There were several occasions where the disk provided by DISA/Houston Associates did not work. This caused great delay because this was always the last thing that DISA/Houston Associates suspected as being wrong. There were many instances during integration where the full crew at

both sites waited for the long haul to become operational. By the time we conducted the experiment all these problems had been resolved and the DSI was very reliable.

- **Lesson Learned**

Always have at least two Long Haul tests prior to the experiment. This will help identify any hardware or software problems associated with the DSI. The following suggestions should be considered:

- a) Contact key DISA and Houston Associates management prior to start of integration and experiment and status with them regularly throughout these periods.
- b) Require 24 hour, 7 day uninterrupted service throughout all integration and experiment periods.
- c) Attempt connectivity between sites at least one week prior to the need date (to ensure key availability, etc.).
- d) Ensure proper long haul network operation at least one hour before need time each day.
- e) Require proper safeguards on all net control points throughout the network to prevent unauthorized change of network parameters.

6.1.4 Communication Between Sites

- **Observation**

Inadequate real time communication between Long Haul sites during integration and troubleshooting.

- **Discussion**

Maintaining good communication between Long Haul sites was difficult. Several times during the integration and experiment Armstrong Lab and the AVTB complained they were not being informed about what to do next.

While troubleshooting the system during long haul integration and also during the experiment, an open speakerphone was used for communication between the engineers at the sites. This proved to be restrictive and unmanageable as it was necessary to return to the telephone each time we needed to speak with engineers at the other site. This resulted in reduced efficiency thereby causing delays on solving problems.

- **Lesson Learned**

Have a good communication plan and schedule between sites. Also have designated points of contact at each site so that all issues are channeled through them. When conducting a Long Haul experiment use a wireless, portable, headset that provides full duplex, multi-party long distance telephone capability.

6.1.5 SINCGARS Radio Emulator (SRE) and ASTi Radio Model

- **Observation**

The SRE worked intermittently throughout the experiment. The ASTi Radio Model was very reliable.

- **Discussion**

At the outset of the experiment, the reliability of the SRE was very poor. A decision was made to place the SRE on a separate DIS network in order to reduce PDU traffic, but it did not work. Then we decide to staff each SRE so that it could be re-started each time it crashed. This increased the operational time of the system but did not fully solve the problem. For the length of the experiment, the radios had to be continuously reset. We replaced the Squadron Commander and S3 SRE with ASTi radios, which was very reliable and helped maintain the Command Control link.

- **Lesson Learned**

Do not use the SRE with large entity count exercises, or upgrade the hardware with faster processors and more memory. The ADST II CDF Upgrades program should also analyze the problem, especially in the area of the SRE's network interface, to see if software modifications and/or enhancements are necessary to improve reliability in a large entity count experiment. ASTi Radios provide a cost effective means of communications in a demanding C2 environment, although at a lower level of fidelity for ground radio propagation effects.

6.2 Administration

6.2.1 Data Collection Forms

- **Observation**

Manual data collection forms were not initially tailored well to the experiment.

- **Discussion**

The data collection forms were not available to all sites during the initial runs. Data collectors were not informed about how to use the data collection sheet or when they would get them.

- **Lesson Learned**

Utilize the experience of the Research Assistants early on for development of manual data collection forms tailored to an experiment. The customer must develop a plan on how manual data collection is to be conducted as early on in the DO as possible.

6.2.2 Experiment Schedule

- **Observation**

Do not schedule a system "fix" week during a holiday period.

- **Discussion**

Due to scheduling problems with the troops, VIE started immediately after the Christmas holidays. This created a long down time in which the simulation test bed was not utilized and problems could not be worked.

- **Lesson Learned**

Schedule must adapt for holiday periods without compromising the experiment.

6.3 ModSAF

- **Observation**

The ModSAF workstations would send corrupted data in the DIS Entity State PDU that would crash the SIMNET simulators.

- **Discussion**

During several runs some ModSAF entities were generating Entity State PDUs that had corrupted xyz coordinates called NANs (Not a Number), which crashed the simulators at Knox and Rucker. The problem seemed to occur when the entities were driving over a specific terrain area. In order to resolve the problem quickly, we decided to add code to ModSAF that detected when NANs were being generated and then give them a valid default value before they went over the network.

- **Lesson Learned**

During integration and the experiment, monitor the network for NANs. A complete regression test must be performed on the NTC database to find possible terrain patches that are corrupted.

6.4 Hardware

6.4.1 Manned Simulators

- **Observation**

The ADST M1 simulators experienced hard drive failures during integration. During the experiment there were several component failures both for the M1 and M2 simulators.

- **Discussion**

During integration several hard drives crashed and had to be reformatted. The same hard drives would continue to fail, so we decided to buy hard drives for all the simulators. The new hard drives increased the reliability of the simulators. There were other component failures like Laser Range Finders, Commander and Gunner control handles, and Vision Blocks. All were fixed in a timely manner during the experiment.

- **Lesson Learned**

Some hardware down time should be planned for in the development of the experiment schedule. Also simulators at the MWTB should be on a regular maintenance schedule so that they can be used at any time. The simulators used for VIE had not been maintained and used in months.

7. Conclusion

The Virtual Integration Experiment achieved its objective of identifying the decision making process a unit commander would use in employing new Battle Combat ID technologies. The insights gained from this experiment will allow for the continued development of Combat ID tactics, techniques, and procedures for future simulations.

8. Points of Contact

Contractor VIE Team

Bill Hopkinson	William.C.Hopkinson@cpmx.saic.com
Ralph Forkenbrock	Ralph.Forkenbrock@cpmx.saic.com
Gilbert Gonzalez	GILBERT.GONZALEZ@cpmx.saic.com

STRICOM Point of Contact

Chris Metevier	Chris_Metevier@stricom.army.mil
----------------	---------------------------------

9. Acronym List

AAR	After Action Review
ACTD	Advanced Concepts Technology Demonstration
AMSAA	Army Materiel Systems Analysis Activity
ADST	Advanced Distributed Simulation Technology
AVTB	Aviation Test Bed
BCIS	Battlefield Combat Identification System
BLEP	Battle Lab Experiment Plan
CAS	Close Air Support
CDRL	Contract Data Requirements List
CECOM	Communications and Electronics Command
DED	Dynamic Entity Database
DO	Delivery Order
DIS	Distributed Interactive Simulation
DISA	Defenses Information Systems Agency
DSI	Defense Simulation Internet
DSM	Don't Shoot Me
ETAC	Enhanced Terminal Air Controller
EPLRS	Enhanced Position Location Reporting System
FLIR	Forward Looking Infrared
FPE III	Force Protection Experiment III
FO/FAC	Forward Observer / Forward Air Controller
FRAGO	Fragmentary Order
FWA	Fixed Wing Aircraft
GFE	Government Furnished Equipment
INES	Improved Network Encryption System
IP	Internet Protocol
JCSAR	Joint Combat Search and Rescue

M1	Version of the Abrams Main Battle Tank
MB	Megabyte
MBBL	Mounted Battlespace Battle Lab
MELIOS	Mini Eyesafe Laser Infrared Observation Set
ModSAF	Modular Semi-Automated Forces
MOE	Measure Of Effectiveness
MPDD	Multi-Purpose Data Display
MTC	Movement to Contact
MWTB	Mounted Warfare Test Bed
NAN	Not A Number
NVESD	Night Vision Electronic Sensor Division
OPFOR	Opposing Forces
OS	Operating System
OSF	Operational Support Facility
OTW	Out-The-Window
PC	Personnel Computer
PDU	Protocol Data Unit
PM	Program Manager
PVD	Plan View Display
RP	Role Player
RWA	Rotary Wing Aircraft
SA	Situational Awareness
SADL	Situational Awareness Data Link
SAF	Semi-Automated Forces
SATIDS	Situational Awareness Tactical Internet Data Server
SCO	Santa Cruz Operating System
SGI	Silicon Graphics, Inc.
SIMNET	Simulation Network
SINCGARS	Single Channel Ground and Airborne Radio System
SIP+	System Improvement Program Plus

SME	Subject Matter Expert
SRE	SINCGARS Radio Emulator
SRM	SINCGARS Radio Model
STRICOM	(US Army) Simulation, Training, and Instrumentation Command
TC	Tank Commander
TI	Tactical Internet
TIM	Tactical Internet Model
TIM	Technical Interchange Meeting
TRR	Test Readiness Review
TTP	Tactics, Techniques, and Procedures
VDD	Version Description Document
VMF	Variable Message Format
VTC	Video Teleconference
VVVS	Versatile Virtual Vehicle Simulator
WF	War Fighter
XCIAU	Translator Cell Interface/Adapter Unit