

**ADVANCED DISTRIBUTED
SIMULATION TECHNOLOGY II
(ADST II)**

Final Report

CDRL AB01

For

DO #068

***FORCE XXI BATTLE COMMAND BRIGADE & BELOW
(FBCB2) INTO FORT HOOD SIMNET***



For:

US Army
Simulation, Training, and Instrumentation Command (STRICOM)
12350 Research Parkway
Orlando, Florida 32826-3224

By:

Science Applications International Corporation
12479 Research parkway
Orlando, FL 32826-3248



Lockheed Martin
Information Systems Company
12506 Lake Underhill Road
Orlando, FL 32825

LOCKHEED MARTIN



Approved for public release; distribution unlimited.
UNCLASSIFIED

DTIC QUALITY INSPECTED 4

19991115 066

REPORT DOCUMENTATION PAGE

Form Approved
OMB No. 074-0188

Public reporting burden for this collection of information is estimated to average 1 hour per response, including the time for reviewing instructions, searching existing data sources, gathering and maintaining the data needed, and completing and reviewing this collection of information. Send comments regarding this burden estimate or any other aspect of this collection of information, including suggestions for reducing this burden to Washington Headquarters Services, Directorate for Information Operations and Reports, 1215 Jefferson Davis Highway, Suite 1204, Arlington, VA 22202-4302, and to the Office of Management and Budget, Paperwork Reduction Project (0704-0188), Washington, DC 20503

1. AGENCY USE ONLY (Leave blank)	2. REPORT DATE 26 FEB 1999	3. REPORT TYPE AND DATES COVERED final
---	--------------------------------------	--

4. TITLE AND SUBTITLE Advanced Distributed Simulation Technology II (ADST-II) Force XXI Battle Command Brigade & Below (FBCB2) Into Fort Hood Simnet	5. FUNDING NUMBERS N61339-96-D-0002
---	---

6. AUTHOR(S)	
---------------------	--

7. PERFORMING ORGANIZATION NAME(S) AND ADDRESS(ES) Lockheed Martin Information Systems ADST-II P.O. Box 780217 Orlando Fl 32878-0217	8. PERFORMING ORGANIZATION REPORT NUMBER ADST-II-CDRL-FBCB2-9900035
---	---

9. SPONSORING / MONITORING AGENCY NAME(S) AND ADDRESS(ES) NAWCTSD/STRICOM 12350 Research Parkway Orlando, FL 32328-3224	10. SPONSORING / MONITORING AGENCY REPORT NUMBER
---	---

11. SUPPLEMENTARY NOTES

12a. DISTRIBUTION / AVAILABILITY STATEMENT Approved for Public release; distribution is unlimited	12b. DISTRIBUTION CODE
---	-------------------------------

13. ABSTRACT (Maximum 200 Words) The Force XXI Battle Command Brigade & Below (FBCB2) into Fort Hood SIMNET training was conducted at the Simulation Network (SIMNET) facility at Fort Hood, TX, from June 1, 1998 to the beginning of the FBCB2 Limited User Test (LUT). The Delivery Order (DO) was performed as Delivery Order #68 under the Lockheed Martin Advanced Distributed Simulation Technology II (ADST II) Contract administered by the U.S. Army Simulation, Training, and Instrumentation Command (STRICOM). The training utilized a synthetic environment that employed virtual simulations to depict a platoon or company executing three basic scenarios in realistic combat. The scenarios were developed to run on the Fort Hood terrain database. The scenarios included Attack, Defense in Sector and Movement to Contact vignettes. These scenarios were designed to produce effective training on the use of FBCB2 capabilities in a realistic combat situation. To support the Army's Task Force XXI (TF XXI) Advanced Warfighting Experiment (AWE), STRICOM helped to establish a simulation facility at Fort Hood, TX in June of 1996. This facility employs man in the loop SIMNET simulators, computer generated forces, and real-world Command & Control (C2) systems, such as Appliqué.

14. SUBJECT TERMS STRICOM, ADST-II, SIMNET, simulation, , Training, Task Force XXI	15. NUMBER OF PAGES 25
	16. PRICE CODE

17. SECURITY CLASSIFICATION OF REPORT UNCLASSIFIED	18. SECURITY CLASSIFICATION OF THIS PAGE UNCLASSIFIED	19. SECURITY CLASSIFICATION OF ABSTRACT UNCLASSIFIED	20. LIMITATION OF ABSTRACT
---	--	---	-----------------------------------

EXECUTIVE SUMMARY	v
1 INTRODUCTION	1
1.1 Purpose	1
1.2 Contract Overview	1
1.3 Training Overview	1
1.4 Technical Overview	1
2 Applicable Documents	2
2.1 Government	2
2.2 Non-Government	2
3 System Description	2
3.1 System Configuration and Layout	2
3.2 Description of System Components	6
3.2.1 Manned Modules M1 & M2	6
3.2.2 FBCB2	6
3.2.3 Situational Awareness Tactical Internet Data Server (SATIDS)	6
3.2.4 Initialization GUI (InitGUI)	7
3.2.5 Precision Lightweight GPS Receiver (PLGR)	7
3.2.6 Translator Cell Interface/Adapter Unit (XCIAU)	7
3.2.7 ModSAF Operations	7
3.2.8 Data Logger	7
3.2.9 Stealth System	8
3.2.10 DIS/SIMNET/VMF LAN Network Configuration	8
3.2.11 Radio Communications	8
3.2.12 Operator Control Station	9
3.3 Database and Scenario Development	9
3.4 Image Generator (IG) Visual Models	9
4 Conduct of The Training	10
5 Observations and Lessons Learned	11
6 Analysis Summary	12
7 Future Development to Support SIMNET Facility	14
8 Conclusion	15
9 Points of Contact	16
10 Acronym List	17

List of Figures

Figure 1 Fort Hood SIMNET Facility Network Diagram	3
Figure 2 Fort Hood SIMNET Facility Floor Plan Layout	5

List of Tables

Table 1 ADST II Fort Hood SIMNET Facility Assets	4
--	---

Executive Summary

Background

The Force XXI Battle Command Brigade & Below (FBCB2) into Fort Hood SIMNET training was conducted at the Simulation Network (SIMNET) facility at Fort Hood, TX, from June 1, 1998 to the beginning of the FBCB2 Limited User Test (LUT). The Delivery Order (DO) was performed as Delivery Order #68 under the Lockheed Martin Advanced Distributed Simulation Technology II (ADST II) Contract administered by the U.S. Army Simulation, Training, and Instrumentation Command (STRICOM). The training utilized a synthetic environment that employed virtual simulations to depict a platoon or company executing three basic scenarios in realistic combat. The scenarios were developed to run on the Fort Hood terrain database. The scenarios included Attack, Defense in Sector and Movement to Contact vignettes. These scenarios were designed to produce effective training on the use of FBCB2 capabilities in a realistic combat situation.

To support the Army's Task Force XXI (TF XXI) Advanced Warfighting Experiment (AWE), STRICOM helped to establish a simulation facility at Fort Hood, TX in June of 1996. This facility employs man in the loop SIMNET simulators, computer generated forces, and real-world Command & Control (C2) systems, such as Appliqué.

The primary purpose of the SIMNET/Appliqué site was to train the Experimental Force (EXFOR) soldiers for participation in the AWE (AWE 97-05). The site was used for training of Platoon lanes up to Company lanes with the Appliqué C2 system. Modular Semi-Automated Forces (ModSAF) were used to provide round-out friendly forces, as well as opposing forces (OPFOR). The combined Appliqué/SIMNET/ModSAF training was accomplished by installing Appliqué hardware replicas (mock-ups of Appliqué V2 hardware) into the SIMNET devices similar to where the actual equipment is located in the real M1 tanks and M2 Bradley Fighting Vehicles (BFVs). These Appliqué replicas operate using the actual Appliqué software releases. The initial training version of Appliqué was 1.0d, operational on 1 June 1996. The site was later upgraded to Appliqué version 1.01a on 15 September 1996, and to version 1.02a shortly thereafter.

The next version of the Appliqué C2 hardware and software has been entitled FBCB2.

The objective of this effort was:

Upgrade the C2 systems at the Fort Hood SIMNET site to FBCB2 version 2.0, and subsequently to version 2.1 and provide realistic situational awareness data through the use of the Situational Awareness Tactical Internet Data Server (SATIDS).

SATIDS was upgraded to work with a new Variable Message Format (VMF). The Initialization GUI (InitGUI) was upgraded to work with the new version of FBCB2. The work took place at both the Operational Support Facility (OSF) in Orlando, FL and the Fort Hood SIMNET Facility.

Training started on schedule from June 1, 1998 and continued until the beginning of the FBCB2 LUT in August 1998.

In accordance with the Government Statement of Work (SOW), this Final Report includes a summary of the FBCB2 upgrade analysis, a "blue print" of the Fort Hood SIMNET FBCB2

system's architecture, and lessons learned. This report addresses the interconnectivity of simulation systems, modifications to the InitGUI, and the integration of Government Furnished software models. This report does not include discussion of data analysis nor conclusions as to whether the customer(s) achieved their objectives of the Delivery Order.

1 INTRODUCTION

1.1 Purpose

The purpose of this final report is to document the ADST II effort that supported the FBCB2 DO. This report includes a full description of the effort, its architectural design, its conditions, and lessons learned. In addition, this report provides recommendations on how to further upgrade the SIMNET C4I capability.

1.2 Contract Overview

FBCB2 was performed, as DO #0068 under the Lockheed Martin Corporation (LMC) ADST II contract with STRICOM. The Unilateral Delivery Order (UDO) required LMC to analyze the hardware and software requirements for FBCB2, configure and integrate the Fort Hood SIMNET Facility assets for training troops before the FBCB2 LUT.

1.3 Training Overview

The purpose of the FBCB2 DO was to use man-in-the loop simulators, and simulated forces to train troops for the FBCB2 LUT. The training employed eighteen manned simulators. Fourteen of the manned simulators were SIMNET M1 simulators. The final four manned simulators were SIMNET M2 simulators.

The simulators were augmented with role players and ModSAF to depict a platoon or company that conducted tactical operations against a doctrinally approved and depicted Opposing Force (OPFOR) ModSAF threat.

1.4 Technical Overview

The technical approach to the FBCB2 DO involved the analysis of the past training, analysis of new requirements for this training, development of software, and the configuration and integration the Fort Hood SIMNET Facility assets into the training configuration.

Software development was conducted primarily at the Operational Support Facility (OSF) in Orlando, FL, with additional work on site at the Fort Hood SIMNET Facility.

2 Applicable Documents

2.1 *Government*

ADST II Delivery Order Statement of Work for Force XXI Battle Command Brigade & Below (FBCB2) into Fort Hood SIMNET (FBCB2 DO), January 25, 1998, AMSTI-98-WO10.

2.2 *Non-Government*

None.

3 System Description

3.1 *System Configuration and Layout*

The Fort Hood SIMNET Facility contains a variety of simulators, networks, ModSAF capabilities, displays for monitoring the battlefield, utilities to facilitate exercises, and automated data collection, reduction, and analysis capabilities. The Fort Hood SIMNET Facility Network is depicted in Figure 1.

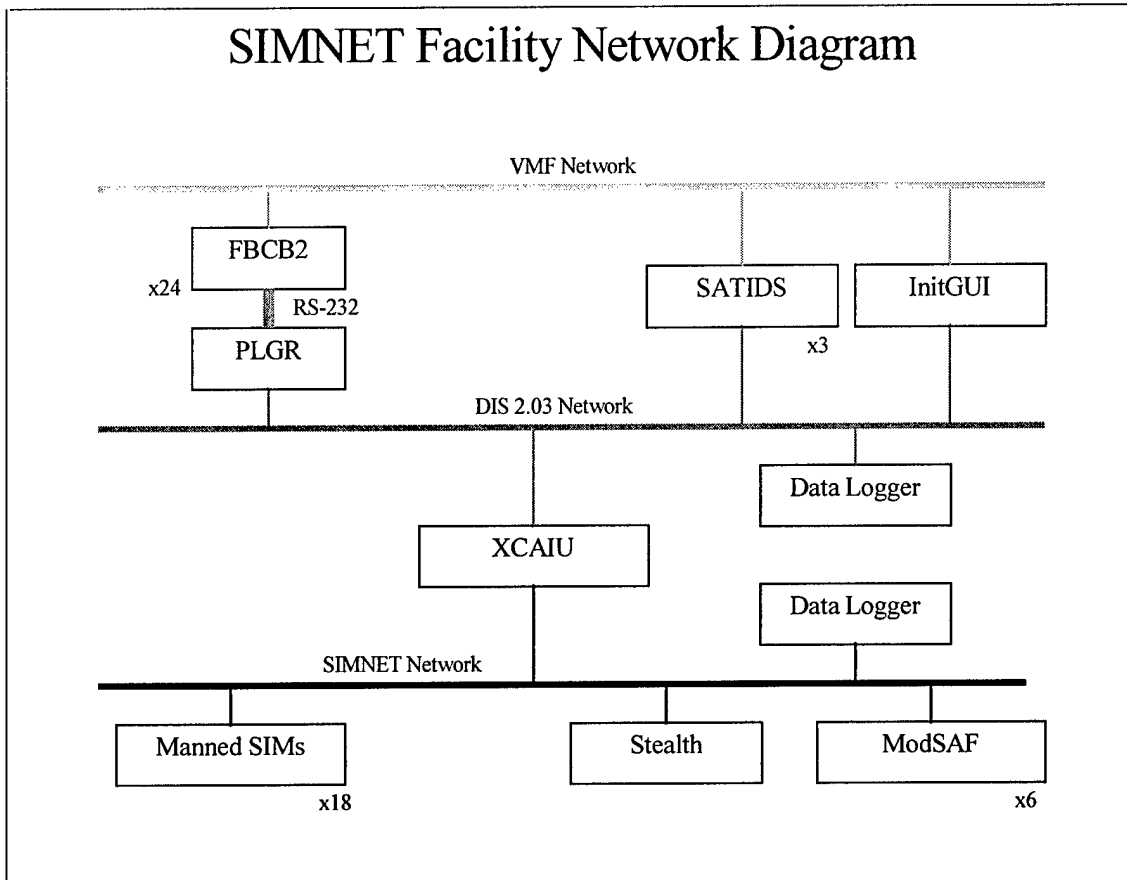

Figure 1 Fort Hood SIMNET Facility Network Diagram

The training was conducted using assets interconnected on Ethernet LANs via twisted pair cable. Simulation assets used either Distributed Interactive Simulation (DIS) 2.03 protocol, Simulation Network (SIMNET) protocol or Variable Message Format (VMF) protocol. Up to three exercises are capable of being run. This is due to only three machines with SATIDS. Table 1 lists assets used at the Fort Hood SIMNET Facility.

SIMNET FACILITY ASSET	PURPOSE	PROTOCOL
Fourteen M1 SIMNET Manned Simulators.	Fills Platoon and Company unit positions.	SIMNET
Four M2 SIMNET Manned Simulators.	Fills Platoon and Company unit positions.	SIMNET
One Stealth (GT101).	Battlefield Visualization Display for Commander Role-player	SIMNET
Twenty-four FBCB2/V2(PCs, 330 MHz, Solaris 2.6).	FBCB2 software installed on PC with V2 hardware inside the simulator.	VMF
Six ModSAF Workstations(SGI Indigo2s, Irix 6.2 or SGI Indys, Irix 5.3).	Semi-Automated Forces for BLUFOR and OPFOR. Also used for Company Commanders and Artillery positions.	SIMNET
Three SATIDS (SUN Ultra 1 with SUN OS 5.5.1).	Simulates the digital side of the Tactical Internet. Provides position information to and simulates FBCB2s for SAF entities	DIS2.03 & VMF
Twelve PLGRs (PCs, Linux OS).	Provides simulated GPS information to FBCB2 in manned simulators.	DIS 2.03 & GPS Standard
One XCIAU (SGI Indigo 2, Irix 6.2).	Translates between SIMNET and DIS Protocols. Can run multiple exercises.	SIMNET & DIS 2.03
Twenty-five CB Radios.	Radio Communications	NA
Two Data Loggers (SGI Indy, Irix 5.3).	Record of DIS or SIMNET PDUs for Data Collection & Analysis	SIMNET/DIS 2.03

Table 1 Fort Hood SIMNET Facility Assets

In addition to the manned simulators and assets listed in Table 1 above, there were five SGI workstations, three SUN Ultras, and one GT101 required to support the training. Figure 2 depicts the Fort Hood SIMNET Facility Floor Plan layout.

Communications were conducted over CB Radios

Fort Hood SIMNET Facility Floor Plan

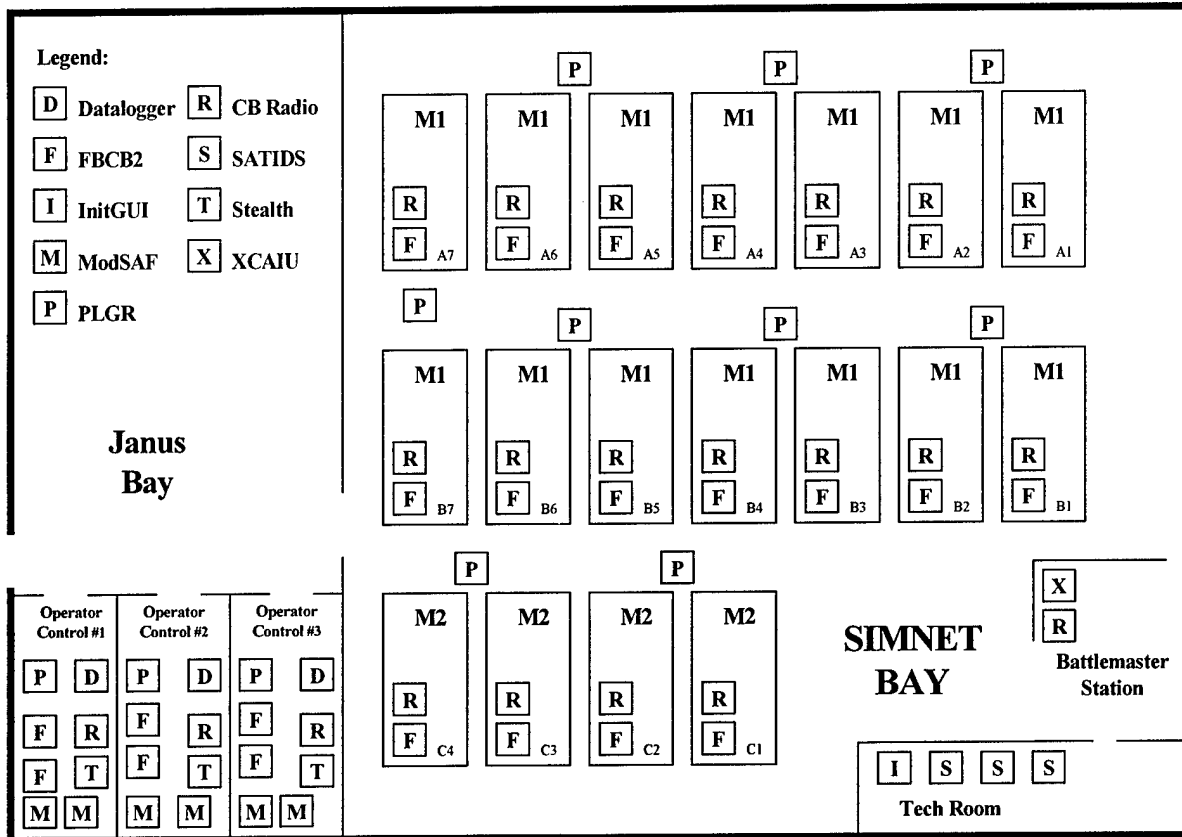

Figure 2 Fort Hood SIMNET Facility Floor Plan Layout

3.2 Description of System Components

This section discusses the description, functionality and operation of the system components, which includes the Government Furnished Equipment (GFE) models and their integration with the hardware at the Fort Hood SIMNET Facility.

3.2.1 Manned Modules M1 & M2

The M1 manned modules replicates a real M1 armored vehicle. The purpose of the M1 manned modules was to provide troops a realistic as possible training environment for the FBCB2 LUT. Each module contains four crewmen, a Commander, Gunner, Loader and Driver.

The M2 manned modules replicates a real M2 armored vehicle. The purpose of the M2 manned modules was to provide troops a realistic as possible training environment for the FBCB2 LUT. Each module contains three crewmen, a Commander, Gunner, and Driver.

3.2.2 FBCB2

The FBCB2 Command and Control Tactical Display was provided as GFE. The previous version of FBCB2 hardware and software was referred to as Appliqué. The Appliqué hardware mockups were used with the FBCB2 software. FBCB2 provides situational awareness by displaying locations of Blue Force units on a continuously updated map. The FBCB2s were placed in M1 and M2 manned simulators. The FBCB2 display was mounted for use by the vehicle commander. Two FBCB2s were also displayed on Personal Computers in the Operator Control Stations.

FBCB2 was installed on a 330MHz Micron Personal Computer with 64MB of RAM and a 1.6GB hard drive, and was loaded with the SUN Microsystems Solaris 2.6 Desktop UNIX operating system for Intel Platforms. During the course of the DO FBCB2 Version 2.0 was replaced by v2.1 and sequentially v2.1a.

3.2.3 Situational Awareness Tactical Internet Data Server (SATIDS)

SATIDS is a real-time DIS simulation that models realistic SA dissemination via the Army's Tactical Internet (TI). The SA data consists primarily of vehicle position reports. SATIDS models the Tactical Internet (TI) and bridges the simulated environment and real Command and Control (C2) devices like FBCB2s. The modeling includes the delays associated with messages routing through the TI, as well as radio linkage/propagation effects and simulated voice contention. The SATIDS receives Distributed Interactive Simulation (DIS) Entity State PDUs from the manned simulators and ModSAF. This information is used to model the interactions of the entities' SA data. The server understands that real FBCB2s are on the network and sends Variable Message Format (VMF) messages. SATIDS provides a way for entities and applications in the DIS environment to send their positions to FBCB2s. Additional functionality was added to subject Command and Control messages sent by the operator to the above communications effects. Also Spot Reports sent out on the DIS Network by ModSAF using Signal PDUs are captured and translated into a VMF Observed Position Report and subjected to the above communications effects. SATIDS runs on a SUN Ultra 1 workstation with Solaris 5.5.1 OS.

3.2.4 Initialization GUI (InitGUI)

The Initialization System Graphical User Interface (InitGUI) was created to semi-automate, speed up, and minimize the possibility of errors in the initialization process for each exercise. The InitGUI runs on an SGI Indigo 2 workstation with a minimum of 200 MB hard disk space and 128 MB RAM. The Initialization system defines a "scenario" and initializes machines in the scenario.. It also downloads the specific scenario data to the PLGRs, XCAIU, and FBCB2s. A "scenario" is the definition of exercises, roles and other data for all simulators and surrogate systems. The application uses a database of Tactical Internet Model (TIM) and site information along with a set of script files that are executed in response to various actions requested by the user.

3.2.5 Precision Lightweight GPS Receiver (PLGR)

The PLGR eavesdrops on the DIS 2.03 Network for position information as a part of the state update broadcast by that platform, then synthesizes GPS inputs for the FBCB2 that reflect the position of that particular vehicle among all that are active on the network. In an actual vehicle, the same FBCB2 hardware and software interoperate with a paired Global Positioning System (GPS) receiver and tactical digital communications link as a part of the digital command and control network. The PLGRs host computers are paired with all FBCB2s on all the manned modules and in the Operator Control Stations. The PLGRs provided location data for a vehicle specified using the Initialization GUI. The PLGRs operated on a PC with a Linux operating system Version 1.3.59. No modifications were made to the PLGR software or hardware for this Delivery Order.

3.2.6 Translator Cell Interface/Adapter Unit (XCIAU)

The Translator Cell Interface/Adapter Unit (XCIAU) is a bi-directional protocol translator between SIMNET and DIS 2.03 protocols. This allows simulations using different protocols to operate together. The XCIAU translated between SIMNET simulators and ModSAF on the SIMNET side and PLGRs and SATIDS on the DIS 2.03 side. The XCIAU operated on an SGI Indigo2 system with 128 MB RAM and 2 GB hard drive.

3.2.7 ModSAF Operations

ModSAF was used for Blue and Red Forces. The Blue Forces provided the additional units required to fill-out training exercise. Red Forces were provided to complete the scenario requirements. ModSAF operated on SGI Indigo2s and Indys and ModSAF software version 1.5 or 2.0 depending on the scenario. No modifications were made to the ModSAF software for this Delivery Order.

3.2.8 Data Logger

The Data Logger is an ADST II asset that captures the network traffic and places the data packets on a disk or tape file. The Data Logger performs the following functions:

- a. Packet Recording - Receives packets from the DIS or SIMNET network time stamps and then writes to a disk or tape.
- b. Packet Playback - Packets from a recorded exercise can be transmitted in real time or faster than real time. The Data Logger can also suspend playback (freeze time) and skip backward or forward to a designated point in time. The logger can

be controlled directly from the keyboard or remotely from the Plan View Display (PVD). Playback is visible to any device on the network (PVD, Stealth Vehicle, a vehicle simulator, etc.).

The Data Logger operated on an SGI Indy with 200 MHz processor and 128 MB RAM.

3.2.9 Stealth System

The Stealth gives the Observer/Controller (OC) personnel a "window" into the virtual battlefield, allowing them to make covert observations of the action occurring during the scenario. In addition, through the use of the data logger, the Stealth gives observers and analysts an After Action Review (AAR) capability. The Stealth is a visual display platform that consists of a Plan View Display (PVD) map view (2D), various input devices, and three video displays that provide the operator with a panoramic view of the battlefield. The SIMNET Stealth was used during this Delivery Order.

The Stealth permits the controller to fly around the virtual battlefield and view the simulation without interfering with the action. The features of the Stealth allow the observer to survey the virtual battlefield from a variety of different perspectives, including:

- a. Tethered View - Allows the user to attach unnoticed to any vehicle on the virtual battlefield. The Executive Officer was always tethered to his ModSAF vehicle.
- b. Mimic View - Places the user in any vehicle on the virtual battlefield and provides the same view as the vehicle commander.
- c. Orbit View - Allows the operator to remain attached to any vehicle on the virtual battlefield and to rotate 360° about that vehicle, while still maintaining the vehicle as a center point of view.
- d. Free Fly Mode - Permits independent 3-D movement anywhere in the virtual battlefield.

The Stealth operated on a GT-101 system with 12MB of RAM and a 380MB hard drive, and was loaded with GTOS 4.7 operating system.

3.2.10 DIS/SIMNET/VMF LAN Network Configuration

A standard DIS LAN configuration was used with Ten Base T cable. Standard Internet Protocol (IP) was used with the Class C addressing scheme for each LAN

Due to the amount of traffic and differing protocols it was necessary to split the physical network. SIMNET, DIS and VMF traffic were each isolated on their own LANs.

3.2.11 Radio Communications

Radio communications were conducted using Citizens Band (CB) radios. CB radios were positioned at each Operator Controller station, Battlemaster position and manned simulator.

3.2.12 Operator Control Station

The Operator Control Station was used to control the training exercises. They use the room to brief and debrief the soldiers in the training. Two Operators control the exercise from the station. They controlled the training using the ModSAF, Stealth, CB and FBCB2 machines during the exercise. The Operator Controllers with that equipment played the troops Commander and adjacent (SAF) units. They used the Datalogger to debrief the troops after the exercise.

3.3 Database and Scenario Development

The existing Ft Hood terrain database was used to support the experiment. Training scenarios were developed to support the FBCB2 DO. Scenarios depicted platoon or company sized forces conducting Defense in Sector, Attack and Movement to Contact operations.

3.4 Image Generator (IG) Visual Models

The FBCB2 DO used existing visual models.

4 Conduct of The Training

The training began June 1, 1998 and continued through the beginning of the FBCB2 Limited User Test (LUT) in August 1998. Troops first trained in platoon level exercises then company level exercises. Ft Hood SIMNET facility personnel provided classroom and hands-on training consisting of familiarization and orientation on the actual simulation systems and vehicle mockups. Training was provided to personnel of the Ft Hood SIMNET facility on the new software by members of the Delivery Order. Consequently, no direct support was required during training by members of this Delivery Order at the Ft Hood SIMNET Site.

5 Observations and Lessons Learned

- Observation #1

Problems were encountered with loading Solaris 2.6 for Intel Platforms on the Micron Millenium PCs.

- Discussion #1

Due to various bugs in the Solaris 2.6 operating system there were problems getting the software loaded on the Micron PCs.

- Lesson Learned #1

Although there is always an inherent risk involved in integration of any software application, these risks may be minimized. Possible improvements might include allocating more time for testing and modifying the software effort earlier in the schedule. One machine should be ordered early to test the loading of the software. It would also be helpful to include time for resolution of any problems that might arise.

6 Analysis Summary

The Government required that an FBCB2 Upgrade Analysis be done including the following:

- a) Manned simulator (M1 & M2) requirements.
- b) Requirements for FBCB2 integration with the manned simulators and at any other required locations.
- c) FBCB2 PLGR requirements, including if software changes are necessary.
- d) Approach to simulated radio communications for voice and data transmission [such as Tactical Internet Model (TIM), Citizen Band (CB) Radios, Situational Awareness Tactical Internet Data Server (SATIDS), perfect communications, etc.].
- e) Remote administration/initialization system requirements.
- f) ModSAF requirements.
- g) Observer Controller (O/C) stations requirements.

The following are the conclusions of that analysis.

- a) Manned simulator (M1 & M2) requirements.

No changes were required for the manned simulators.

- b) Requirements for FBCB2 integration with the manned simulators and at any other required locations.

Integration of the FBCB2 system at other sites was not necessary to accomplish training for the FBCB2 LUT.

- c) FBCB2 PLGR requirements, including if software changes are necessary.

No changes were required for the FBCB2 PLGR. It was determined that the PLGR would work with the new releases of FBCB2.

- d) Approach to simulated radio communications for voice and data transmission [such as Tactical Internet Model (TIM), Citizen Band (CB) Radios, Situational Awareness Tactical Internet Data Server (SATIDS), perfect communications, etc.].

For voice communications it was determined that CB radios would be sufficient. The TIM was not operational for voice traffic. For digital communication it was determined that SATIDS would be necessary because the TIM/Internet Controller (INC) model was not being updated for this version of FBCB2. SATIDS also provided modeling of voice contention and a more realistic SA picture. Including SATIDS gave the additional benefit of allowing SAF entities to be seen on the FBCB2s

- e) Remote administration/initialization system requirements.

Changes to the InitGUI were required to account for different method of initializing the FBCB2 and changes in the Tactical Internet. Cosmetic changes were also made to the InitGUI at the request of SIMNET Facility personnel.

f) ModSAF requirements.

No changes to ModSAF were needed for the FBCB2 DO.

g) Observer Controller (O/C) stations requirements

No change to the Observer Controller stations was required.

7 Future Development to Support SIMNET Facility

The FBCB2 Delivery Order greatly expanded training at the SIMNET facility. Below are some other recommended improvements that will increase the usefulness of the facility and enhance its training capabilities.

Future development of C4I capabilities of the SIMNET facility could include installing Components of the Army Tactical Command and Control System (ATCCS) Suite such as the Maneuver Control System (MCS) and All Source Analysis System (ASAS). These can be integrated with SATIDS to support a Tactical Operations Center (TOC). SATIDS can support training at the staff level by simulating units and other ATCCS systems.

8 Conclusion

The FBCB2 DO achieved its objective which was to provide troops participating in the FBCB2 LUT, training on the system before they went to the field. The on-time training did allow for a more problem free FBCB2 LUT.

9 Points of Contact

ADST II FPE III Team

Bill Hopkinson	Project Director	407-306-4225	William.C.Hopkinson@cpmx.saic.com
Kevin Mueller	Lead Systems Engineer	407-306-3098	Kevin.Mueller@cpmx.saic.com
Jim Page III	Systems Engineer	407-306-1900	James.Q.Page.III@cpmx.saic.com
Gary Noyes	SIMNET Site Manager	502-942-1092	NoyesG@hood-emh3.army.mil
Don Champagne	SIMNET Lead Engineer	502-942-1092	ChampagneD@hood-emh3.army.mil

STRICOM

Chris Metevier	Project Engineer	407-384-3865	Chris_Metevier@stricom.army.mil
----------------	------------------	--------------	---------------------------------

10 Acronym List

AAR	After Action Review
ADST	Advanced Distributed Simulation Technology
ARPA	Advanced Research Projects Agency
AWE	Advanced Warfighting Experiment
BCV	Battle Command Vehicle
BFV	Bradley Fighting Vehicle
BLUFOR	Blue Forces
C2	Command and Control
C4	Command, Control, Computer and Communications
C2V	Command and Control Vehicle
CB	Citizens Band
CDRL	Contract Data Requirements List
DO	Delivery Order
DIS	Distributed Interactive Simulation
EXFOR	Experimental Force
FBCB2	Force XXI Battle Command Brigade & Below
FRAGO	Fragmentary Order
FTP	File Transfer Protocol
GFE	Government Furnished Equipment
GPS	Global Positioning System
H/W	Hardware
INC	Internet Controller
InitGUI	Initialization Graphical User Interface
IPT	Integrated Product Team
LAN	Local Area Network
LMC	Lockheed Martin Corporation
LUT	Limited User Test

M1	Version of the Abrams Main Battle Tank
M2	Version of the Bradley Fighting Vehicle
ModSAF	Modular Semi-Automated Forces
OC	Operator Controller
OIC	Officer in Charge
OPFOR	Opposing Forces
OPORD	Operations Order
OS	Operating System
OSF	Operational Support Facility
PC	Personal Computer
PDU	Protocol Data Unit
PLGR	Precision Lightweight Global Positioning System Receiver
POC	Point of Contact
PVD	Plan View Display
SA	Situational Awareness
SAF	Semi-Automated Forces
SATIDS	Situational Awareness Tactical Internet Data Server
SGI	Silicon Graphics Industries
SIM	Simulator
SIMNET	Simulation Network
SOV	Staff Operations Vehicle
SOW	Statement of Work
STRICOM	(US Army) Simulation Training and Instrumentation Command
TI	Tactical Internet
TIM	Tactical Internet Model
TOC	Tactical Operations Center
TRADOC	Training and Doctrine Command
TTP	Tactics, Techniques, and Procedures
UDP	User Datagram Protocol
UDO	Unilateral Delivery Order
VMF	Variable Message Format

XCIAU

Translator Cell Interface/Adapter Unit