

A

B

C

D

**The ABCS Program for the
Analysis of Echo Sounder
Returns for Acoustic Bottom
Classification**

Paul A. Clarke and
L.J. Hamilton

DSTO-GD-0215

The ABCS Program for the Analysis of Echo Sounder Returns for Acoustic Bottom Classification

Paul A. Clarke and L. J. Hamilton

**Maritime Operations Division
Aeronautical and Maritime Research Laboratory**

DSTO-GD-0215

ABSTRACT

An echo sounder can be used to indicate the type of sediment on the sea floor through analysis of the returned echo's shape and energy characteristics. This document describes the ABCS program written to analyse echosounder ping returns for simple shape and energy statistics, with the intention to investigate which statistics are important in characterising the seabed. ABCS was written in Visual Basic and can read in the data produced by the Echo Listener device manufactured by Sonar Data Tasmania. Also discussed in this paper is the need to transform all the data obtained to a reference seafloor depth and the method used by ABCS to do this.

RELEASE LIMITATION

Approved for public release

DEPARTMENT OF DEFENCE
DEFENCE SCIENCE & TECHNOLOGY ORGANISATION

DSTO

DTIC QUALITY INSPECTED 4

Published by

*DSTO Aeronautical and Maritime Research Laboratory
PO Box 4331
Melbourne Victoria 3001 Australia*

*Telephone: (03) 9626 7000
Fax: (03) 9626 7999
© Commonwealth of Australia 1999
AR-011-033
August 1999*

APPROVED FOR PUBLIC RELEASE

The ABCS Program for the Analysis of Echo Sounder Returns for Acoustic Bottom Classification

Executive Summary

The type of sediment found in a shallow water environment (less than 200 m depth) has a major effect on the propagation of sound in the water through repeated bottom interaction. If the propagation loss or acoustic backscatter in an area are to be predicted the sediment types in this area must be known. Since the sediment type can change dramatically over short distances in shallow water, the costs involved in taking enough bottom samples and analysing these, even for a small area, could be massive. Therefore investigating a cheaper method of obtaining the sediment type would be worth while.

Since the returned signal from a boat's echo sounder is dependent on the type of sediment, analysing the shape and energy of the returned signal could give the sediment type. This would be a far cheaper method to obtain the sediment type data. Due to the high frequency ranges used by most echo sounders this method will usually give the sediment type for only the thin surface layer of the sea floor.

Analysing echo sounder returns has been done before with varied results, but companies now doing this work regard their processing as proprietary, and methods vary from one manufacturer to another.

To examine how an echo sounder return changes with different sediment types an Echo Listener™ device was attached to the Furuno™ echo sounder on the DSTO Sydney work boat and the program ABCS was written to analyse the returned wave forms.

ABCS reads the files produced by the Echo Listener, finds the seafloor echo sounder returns in the signal, and calculates a number of statistics about them.

Contents

1. INTRODUCTION.....	1
2. THE DATA.....	2
3. THE 'ABCS' PROGRAM.....	2
3.1 Depth Normalisation.....	3
3.1.1 Time Adjustment.....	3
3.1.2 Power Adjustment	4
3.1.3 Effect of Transforming to a Reference Seafloor Depth.....	7
3.2 Running the ABCS Program.....	10
3.3 Statistics Produced.....	14
3.3.1 Second Return Statistics	16
3.4 Problems found from Analysing Test Data	19
4. CONCLUSIONS	20
5. REFERENCES	20
APPENDIX 1: RETURNED PING SHAPE AND ENERGY VARIATIONS WITH SEAFLOOR DEPTH.....	23
APPENDIX 2: GEOMETRIC ERRORS WHEN CONVERTING TO A REFERENCE SEAFLOOR DEPTH.....	27
APPENDIX 3: THE 'LEVELS' PROGRAM.....	29
APPENDIX 4: CALCULATION OF THE POWER RETURNED FROM A CONSTANT POWER INPUT	33
APPENDIX 5: SEARCH AREAS USED BY 'ABCS' TO FIND THE SEAFLOOR RETURNS	41

1. Introduction

The type of sediment found in a shallow water environment (less than 200 m depth) has a major effect on the propagation of sound in the water through repeated bottom interaction (D. Cato et al 1995). If the propagation loss or acoustic backscatter in an area are to be predicted the sediment types in this area must be known. Since the sediment type can change dramatically over short distances in shallow water, the costs involved in taking enough bottom samples and analysing them even for a small area could be massive. Therefore investigating another method of obtaining the sediment type which is cheaper would be worth while.

Since the returned signal from a boat's echo sounder is dependent on the type of sediment, analysing the shape and energy of the returned signal could give the sediment type. This would be a far cheaper method to obtain the sediment type data. Due to the high frequency ranges used by most echo sounders this method will usually give the sediment type for a thin surface layer of the seafloor, similar to the results found from a sediment grab sample. If the sediment types were required deeper into the seafloor then a core sample, or an inversion technique would have to be used.

Analysing echo sounder returns has been done before, with varied results. The main commercial products available now are QTC-View™ and RoxAnn™. RoxAnn uses the energy from the first and second returns¹ to give the sediment type (Burns et al 1989), while QTC-View uses a large number of echo shape parameters from the first return only to give the sediment type (Prager et al 1995). To obtain the sediment type both require calibration, which involves transiting over known sediment types at a similar depth to the area that needs to be surveyed.

The problem with these two products is that the companies now doing this work regard their processing as proprietary. They give out little information on what calculations the units are doing to get a sediment type (this is done to protect the companies' patents). Also there is a high original purchase cost, and the reliance on the companies to keep upgrading the product along with the cost of upgrades. The current cost of the RoxAnn system is around \$20,000 per unit, with QTC-View costing between \$20,000 to \$100,000 per unit depending on what software is purchased. Since little information is given out on what calculations are being done to get the sediment types, the theory behind the calculations can not be investigated and only the manufacturers can do upgrading of the detection methods.

To try to overcome these problems and improve DSTO's understanding of the mathematics used to obtain the sediment types, an Echo Listener device manufactured by Sonar Data Tasmania Pty Ltd was attached to the Furuno™ echo sounder on the

¹ The first return has a single bottom bounce (from a source / seafloor / receiver path), while the second return has two bottom bounces (from a source / seafloor / sea surface / seafloor / receiver path).

DSTO Sydney work boat to record the echo waveforms. A program (called ABCS.exe) was then written to analyse the returned waveforms. This report describes the running of the ABCS program, what shape statistics it produces, and what needs to be considered when running the program. The current version of the ABCS program is not trying to obtain the sediment type. It was written to see how selected shape and energy statistics from the returned echo sounder signal change with sediment type, thus determining which shape statistics are important for sediment classification.

2. The Data

The data used to test the ABCS program was produced using an Echo Listener™ Device. This data was supplied in CSV (comma separated variable) format, and was obtained at a sampling frequency of 13.6 kHz. The echo sounder depth setting was set to 110 m giving 2000 samples per ping. If the data format is changed from CSV a slight modification will have to be made to the ABCS program.

The Echo Listener device is an A/D converter that has been connected in parallel to the Furuno™ echo sounder on the DSTO Sydney work boat. The Echo Listener device can continuously log the returned echo sounder signal onto a PC or laptop without affecting the operation of the echo sounder. The Echo Listener was manufactured and supplied by Sonar Data Tasmania Pty Ltd².

3. The 'ABCS' Program

The ABCS program was written in Visual Basic and consists of five display forms. These are the main display form (which is used to enter the data), three plot displays, and a statistics display form. Only the main display form needs to be open, the others can be opened and closed as required.

This program was not designed to process the pings in real time, but reads the output files from the Echo Listener™ device and calculates the statistics from them in post processing. The current version will be used to examine how selected shape and energy statistics change with sediment type; it is not trying to classify the sediment types.

² For more information on Sonar Data and the Echo Listener see their web site at <http://www.verdant.com.au/SonarData/>

3.1 Depth Normalisation

The shape and power of the returned signal from the seafloor can change significantly with seafloor depth as a result of spreading losses and absorption (see appendix 1), even if the seafloor sediment remains the same. Seafloor depth changes also cause dilation or compression (see appendix 1) of the returned ping. These changes due to seafloor depth variation will effect the shape statistics being calculated by the ABCS program, thus obscuring the changes due to variations in sediment type. To overcome this, the returned signal is transformed to a reference seafloor depth and the statistics calculated at the reference seafloor depth.

To transform a returned signal to the reference seafloor depth, time and power adjustments need to be made. The time adjustment is first made to adjust the duration of the returned ping, which changes due to the different path lengths involved in backscattering the ping from different seafloor depths. The power adjustment then removes the effect of spherical spreading.

3.1.1 Time Adjustment

The time adjustment enables returns from the actual seafloor (depth d) and the reference seafloor (depth d_0) to maintain the same time/angle relationships (Caughey et al 1994). Sampling at the same angles for different seafloor depths removes the need to allow for beam patterns, and for the bottom backscatter function changing with incidence angle.

$$\text{The time adjustment is } \gamma = \frac{d}{d_0} \quad (1) \quad (\text{Caughey et al. 1994})$$

where d = The actual seafloor depth.
 d_0 = The reference seafloor depth.

$$\text{Therefore } t' = \frac{t}{\gamma} = \frac{d_0 t}{d} \quad (2)$$

where t' = The time adjusted to the reference depth.
 t = The actual time of the echo sounder signal from the actual seafloor depth.

These times start at zero when the echo sounder sends the ping, with the time adjustment having the effect of expanding or compressing the returned signal along the time axis.

3.1.2 Power Adjustment

Since the backscattered energy received at the hydrophone from the seafloor is bottom reverberation, this energy received can be found using:

$$RL = SL - 40 \log d + S_b + 10 \log A \quad (\text{D. Cato et al 1995})$$

where RL = The energy flux from the actual seafloor in dB re J/m².

SL = The source level energy of the echo sounder in dB re J/sr.

d = The actual seafloor depth in m.

S_b = The boundary scattering strength in dB.

A = The area of the insonified section of seafloor at the actual seafloor depth in m².

$$A = \pi d^2 \tan \alpha \quad (\text{see Figure 1})$$

The above equation can also be used at the reference depth.

$$RL' = SL - 40 \log d' + S_b + 10 \log A'$$

where RL' = The energy flux from the reference seafloor in dB re J/m².

d' = The reference seafloor depth.

A' = The area of the insonified section of seafloor at the reference depth.

$$A' = \pi d'^2 \tan \alpha \quad (\text{see Figure 1})$$

S_b and SL will be the same at both seafloor depths.

By combining these two equations the change in energy flux with seafloor depth can be found.

$$RL' - RL = 40 \log d - 40 \log d' - 10 \log A + 10 \log A' = 20 \log \left(\frac{d}{d'} \right)$$

This energy flux is converted into a voltage by the hydrophone. Since the hydrophone size is not changing, the area component of the energy flux is constant at both depths. Therefore the change in energy can be written as:

$$E' = \left(\frac{d}{d_o} \right)^2 E \quad (3)$$

where E = The received energy at the hydrophone from the actual seafloor in Joules.

E' = The adjusted received energy for the reference seafloor in Joules.

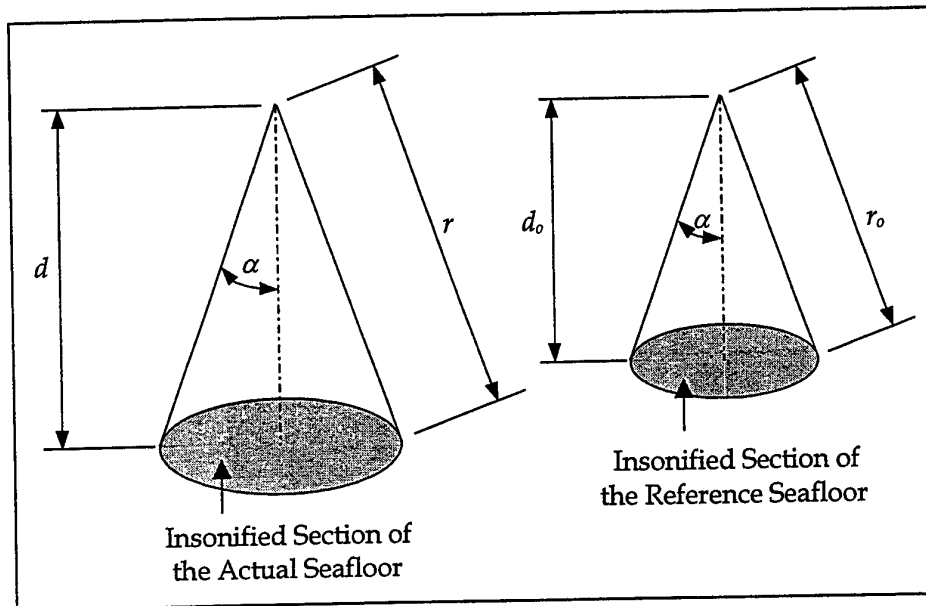

Figure 1: Geometry of the Pulse Insonifying the Seafloor

The Echo Listener produces output files containing the power levels returned from the seafloor, and since equation (2) gives a change in the time scale, this must be considered when calculating the adjusted depth.

$$R' = \frac{dE'}{dt'} , \quad R = \frac{dE}{dt}$$

where R' = The adjusted received power.

R = The actual received power.

Combining these two equations and substituting in equation (3) gives:

$$\frac{R'}{R} = \frac{\frac{dE'}{dt'}}{\frac{dE}{dt}} = \frac{\frac{d}{dt'} \left[\left(\frac{d}{d_o} \right)^2 E \right]}{\frac{dE}{dt}}$$

Since $\frac{d}{dt'} = \gamma \frac{d}{dt}$ (from equation (2)) the above equation can be written as:

$$\frac{R'}{R} = \frac{\gamma \frac{d}{dt} \left[\left(\frac{d}{d_o} \right)^2 E \right]}{\frac{dE}{dt}} = \frac{\gamma E \frac{d}{dt} \left(\frac{d}{d_o} \right)^2 + \gamma \left(\frac{d}{d_o} \right)^2 \frac{dE}{dt}}{\frac{dE}{dt}}$$

But $\frac{d}{dt} \left(\frac{d}{d_o} \right)^2 = 0$, so the power adjustment required is:

$$\frac{R'}{R} = \gamma \left(\frac{d}{d_o} \right)^2 = \left(\frac{d}{d_o} \right)^3 \quad (4)$$

For the first return the transmitted and received angles are the same (ie. α), but for the second return the received angle is not the same as the transmit angle (Heald and Pace 1996). This does not affect the power adjustment equation, since the time adjustment enables returns from the actual seafloor depth and the reference seafloor depth to maintain the same time/angle relationship (Caughey et al 1994). Therefore the time and power corrections can be applied to the whole returned signal.

3.1.3 Effect of Transforming to a Reference Seafloor Depth

Simple adjustments like eq(2) and eq(4) do not give an exact transformation to the reference seafloor depth. Even in a simple case of a flat seafloor and constant backscatter with angle, the above equations don't consider the geometric changes exactly (see appendix 2).

If we were to try to precisely transform the echo sounder returns to a reference seafloor depth the ping duration, ping intensity, and Echo Listener™ sampling rate would have to be changed depending on the seafloor depth. Since this is difficult, simple transformations are done to get the returned signal to a reference seafloor depth.

To test how well the transformations in equations (2) and (4) work, a simple example was considered. Using a number of piece-wise constant power inputs to simulate a sine wave ping envelope (see Figure 2), the program "Levels" was written to see what the returned signals would look like (see appendix 3). The program was run for a 2 msec ping duration (this duration was used since it is the ping duration of the Furuno™ echo sounder) and the effect of transforming a 100 m seafloor depth signal to a reference seafloor depth of 50 m considered (see Figure 3). This showed the transformed signal had the same arrival time and an almost identical power variation with time as the

50 m signal. Therefore for the Furuno echo sounder this transformation should give a good result as long as the environment is close to the assumptions made by Levels. These assumptions made by Levels were an omnidirectional source and receiver, a flat seafloor, and a backscatter strength independent of grazing angle.

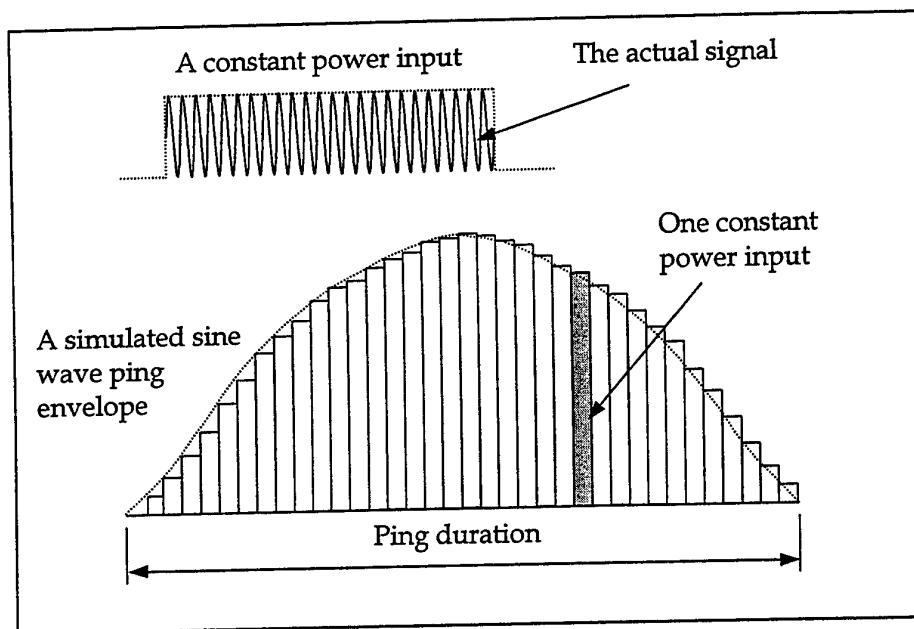

Figure 2: A simulated sine wave ping made up of a number of piece-wise constant segments.

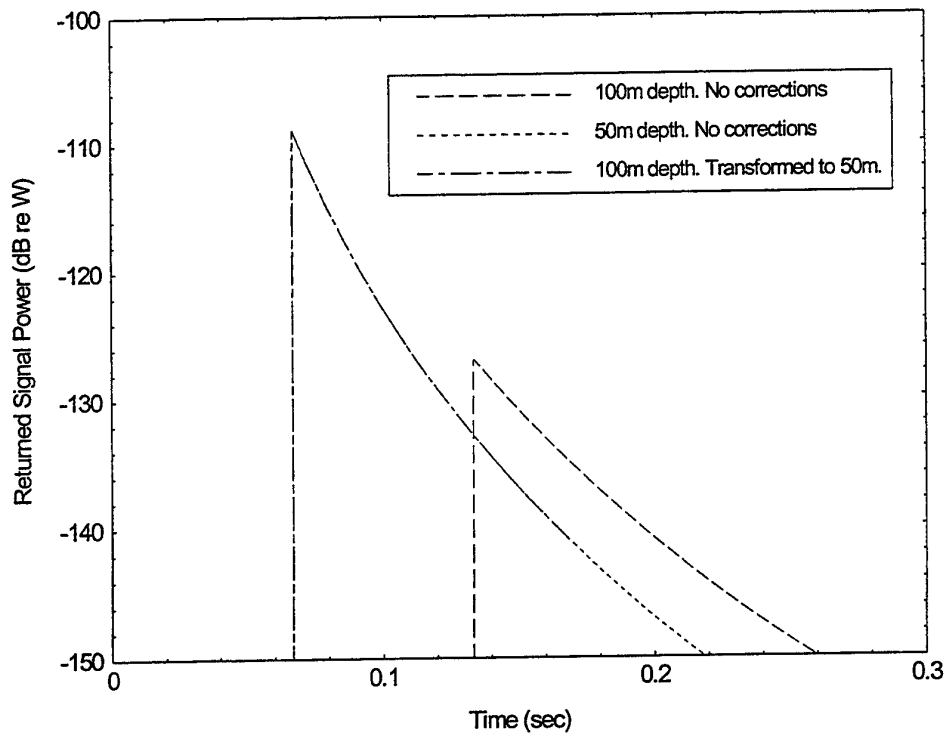

Figure 3 : Returned Signal for a 2 msec Sine Wave Source. The 100 m depth transformed to 50 m and the 50 m depth No corrections lines overlie each other. This plot was calculated using Levels.

If a longer ping duration was used this match would not be as precise, but even a long echo sounder ping of 200 msec with a large change in seafloor depth still has a good match (see Figure 4).

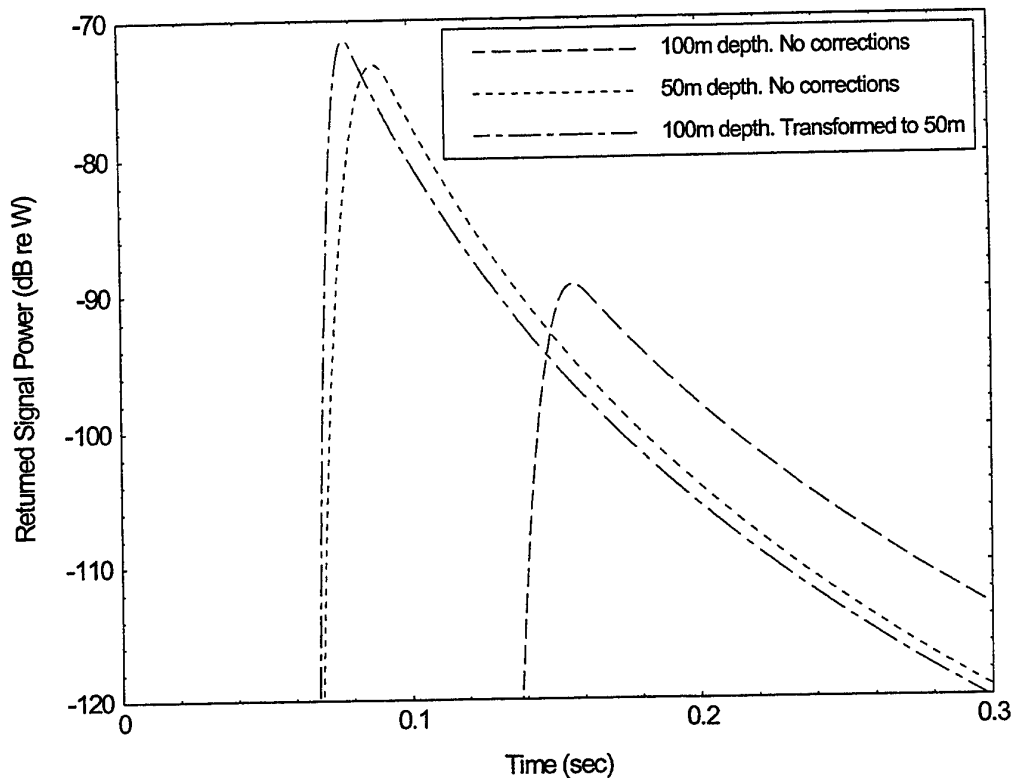

Figure 4: Returned Signal for a 200 msec Sine Wave Source. This plot was calculated using Levels.

3.2 Running the ABCS Program

The ABCS program needs the actual seafloor depth, reference seafloor depth, water sound speed, echo sounder maximum depth setting, time duration of the ping used, and the file containing the received Echo Listener™ returns. All the data are entered on the Main form (Input Values frame). All the operations are done on the Main form (see Figure 5), the other forms are for display only.

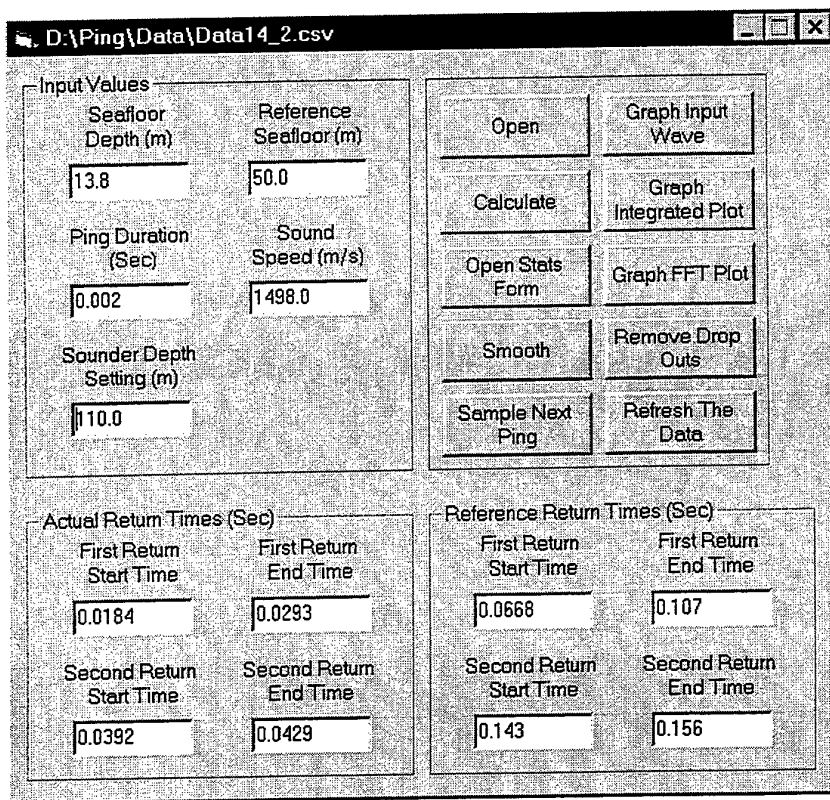

Figure 5: The Main Form for program ABCS. The Actual Return Times and Reference Return Times are calculated by ABCS, these frames can not be changed by the operator.

The first step is to enter the information in the Input Values frame, and then open the CSV file produced by the Echo Listener. The Sounder depth setting must be entered before the file is opened, since after the file is opened this value can no longer be changed. The other values in the Input Values frame can be altered during the analysis as required. To open the echo sounder file press the Open button, and locate the relevant file. The program displays the file name in the header of the Main form. After the file name is entered the program first looks for the file header. This is a listing of all the sampled depths for each ping. By finding how many depth samples exist in the file header, the Echo Listener sampling rate can be found.

$$SamplingRate = \frac{2 \times SounderMaxDepthSetting}{SoundSpeed \times NumberOfHeaderSamples} \quad (5)$$

The numerator is 2 x Sounder Max Depth Setting since this is the return path length.

The file header is also used to determine the number of samples per ping, since each ping in a particular file has the same number of samples. Each ping's set of

returns is analysed one at a time, there is presently no averaging of a number of returns in this version of the program. When recording the data the echo sounder's maximum depth should be set deep enough so that the first and second returns can be recorded before the next ping is sent (ie. the Sounder Depth Setting should be greater than twice the seafloor depth).

The program will then read in the returns for the first ping. The next step is to find the start and end of the first and second returns (The first return is for a single bottom bounce only, while the second has a bottom / surface / bottom bounce), this is done by pressing the Calculate button. The positions of the starts and ends of both returns are found by searching in the expected regions (see appendix 5) for 4 consecutive samples of increasing value (a backwards search is performed to find the ends).

Once the start of the first return is found the actual seafloor depth is calculated and displayed in the Seafloor Depth text box. This new seafloor depth is then used in the calculation of the depth transformation. Also after the start of the first return is found, the background noise level is removed. This is done by averaging over the time before the first return and subtracting this level in the statistics calculations. The points averaged are between the 80th sample and $0.9 \times$ the start time of the first return. The average is not taken from the first sample due to a ringing from the echo sounder appearing in the first few samples.

To view the ping returns and check if the program has found the start and end positions correctly a plot of the ping return can be viewed by pressing the Graph Input Wave button (see Figure 6). The wave plot has different colours showing which returns were found in the return signal. The red line is the original signal, the green line is the first return position calculated, and the blue line is the second return position calculated (see Figure 6). The green and blue lines should encompass the red line at the return sections. If no return is found or a section of it is missed, then the part missed will show up in red (see Figure 7). Also there is a vertical blue line during the first return to show the start of its tail (see Figure 6) (the tail of the first return is from the start of the first return + the ping duration to the end of the first return (see Figure 9)). The red section seen at the beginning of the plot is due to ringing from the echo sounder ping, it is not a bottom return (see Figure 6). The horizontal line at zero (which is normally blue) is for plotting purposes only (see Figure 6).

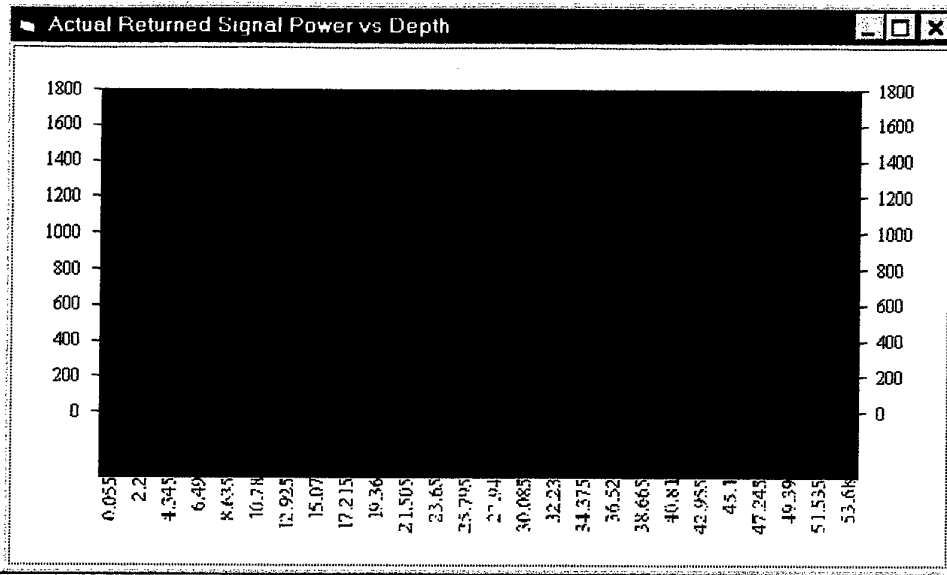

Figure 6: Returned signal for the actual water depth with both returns found correctly. This display is similar to what is seen on an echo sounder display, but only shows one ping. The x axis is depth (m) and can be used to input a new Seafloor Depth into the Input Values frame if the first return is not found correctly. The y axis is power, but there are no units for this axis since the signal is not calibrated.

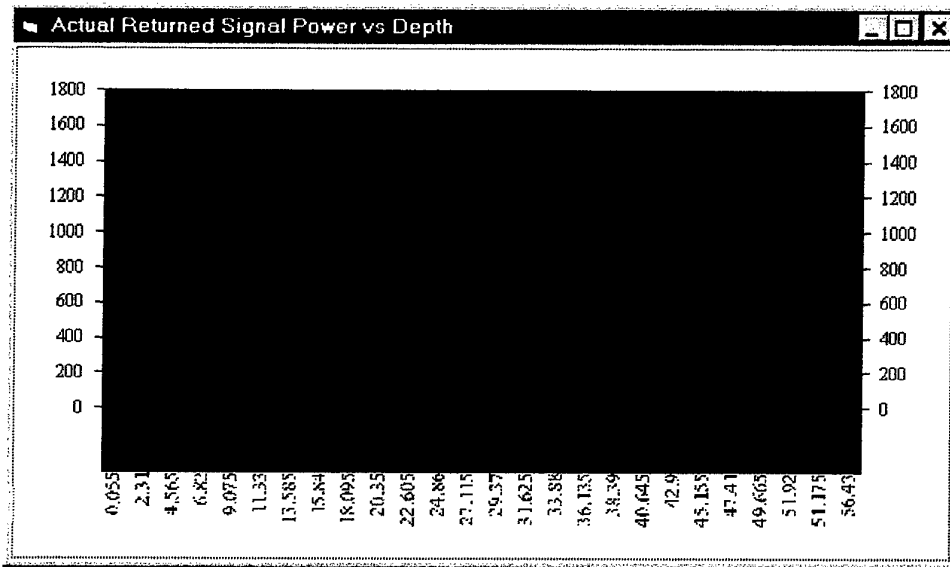

Figure 7: Returned signal when the start of the first return is not found correctly and the second return is not found at all. The red line at around 12 m shows that part of the first return was missed. The red section at 30 m shows that the second return was missed.

If a return is not found because of noise or dropouts then the signal can be smoothed or the dropouts removed by pressing the relevant button. Dropouts should be removed before the signal is smoothed since smoothing will affect the dropout spikes. The smoothing is done using a moving 3-point filter that has a bias of:

$$\text{Power}(ii) = 0.25 \times \text{Power}(ii-1) + 0.5 \times \text{Power}(ii) + 0.25 \times \text{Power}(ii+1) \quad (6)$$

This is used to reduce any high frequency noise in the signal. The dropouts are removed by looking for any very low amplitude signals with higher amplitude signals each side.

Also if the seafloor depth has changed drastically since the last ping and the first return can not be found, a new seafloor depth can be entered in the Seafloor Depth text box. This enables a different section of the return to be searched for the start of the first return. (see appendix 5)

If only the first return is found, statistics for the first return are calculated, and the FFT and Integrated Power plots are produced. To view these forms just press on the relevant buttons.

If the data is smoothed too many times the original waveform can be recovered by pressing the Refresh The Data button.

If a text box in the input values section is changed the current data and any future data will be calculated using the new inputs. The Sounder Depth Setting can't be changed since the echo sounder file is already open. If this was entered incorrectly the program has to be restarted, and this value entered before the echo sounder file is reopened.

After this ping return has been analysed the next ping can be loaded by pressing the Sample Next Ping button. At this time there is no saving of the statistical data produced, because the format of the output data is not yet determined.

3.3 Statistics Produced

First Return Statistics

Once the start and end points have been found for the first return, the following calculations are done on the signal (see Figure 10).

For the whole of the first return;

- The peak power and peak time.
The peak power and times are found by looking for the three consecutive points with the highest sum, between the start and end points. Times are calculated from the start of the first return.
- The half width.
The half width is the time width at half the peak power.
- The centroid position as power and time.
The centroid times are found using the 2nd moments (M. R. Spiegel 1972), while the centroid powers are found by calculating the total energy of the return and the energy from the peak down until it is half the total energy. Times are calculated from the start of the first return.
- The standard deviation, skewness, and kurtosis of power.
The standard deviation, Skewness, and Kurtosis are calculated from moments calculated about the centroid (M. R. Spiegel 1972).

$$s^2 = m_2, \quad a_3 = m_3/s^3, \quad a_4 = m_4/s^4$$
 where s = Standard deviation
 m_2 = 2nd moment about the centroid
 m_3 = 3rd moment about the centroid
 m_4 = 4th moment about the centroid
 a_3 = Skewness
 a_4 = Kurtosis
- The 1st, 2nd, 3rd, and 4th moments of power, calculated from the start of the first return.
- The median power .
- An Integrated Power Plot. Power² vs Time (sec) (see Figure 11).
The integrated power is a cumulative sum of the square of the power normalised to one, with the power summed from the start of the return time. (See Lurton and Pouliquen (1992) for examples.)

- An FFT plot. Power vs Frequency (Hz) (see Figure 12).
The FFT plot was calculated using a Radix 2 decimation (J.G. Proakis and D.G. Manolakis 1989), with the power spectrum ($\text{real}^2 + \text{imag}^2$) being displayed.

When calculating the half widths and centroid powers, the width of the return at a specific power level has to be found. To reduce the effect of the noise in the signal, the curve intercept was found at four points, two points each side of the return's peak. The inside and outside values on each side were found and then averaged (see Figure 8).

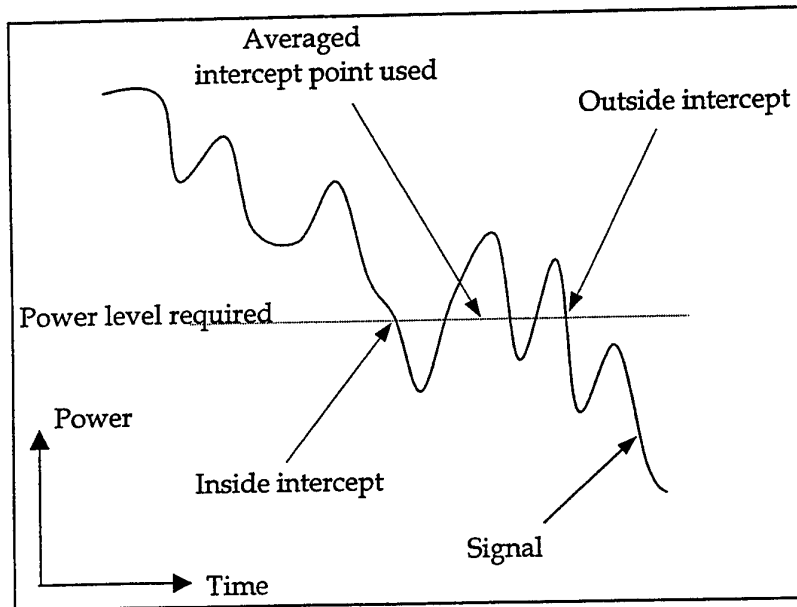

Figure 8 : Intercept point calculation for one side of the peak.

For the tail of the first return;

- The centroid power and time (time is calculated from the start of the first return).
- The energy of the tail. Called the Tail Ref. 1st Return for the reference seafloor depth and Tail 1st Return for the actual seafloor depth, in the energy results frame. The energy for the reference seafloor depth can be compared for different sites. The actual seafloor depth energy can not be used for comparison with other sites, but is more for seeing the strength of the signal returned.

The tail of the first return is from the start of the first return + the ping duration to the end of the first return (see Figure 9).

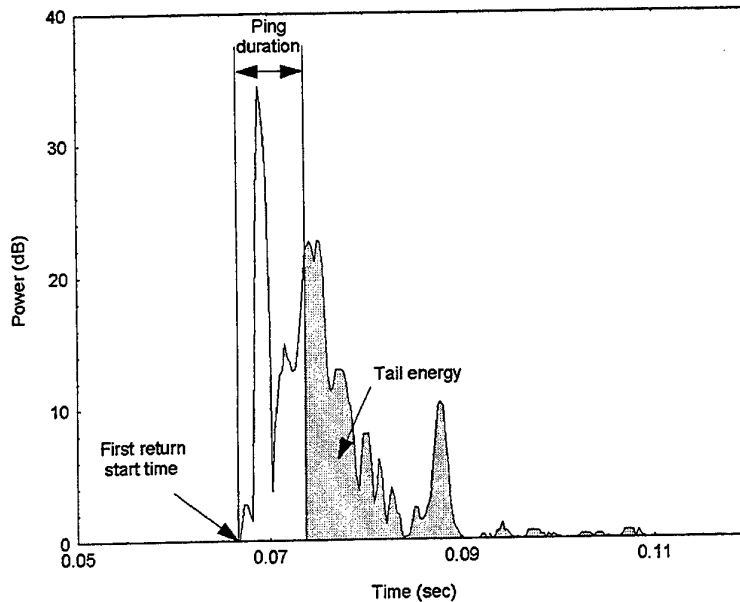

Figure 9: Tail Energy. The power is not calibrated, thus has no units.

3.3.1 Second Return Statistics

For the whole of the second return;

- The peak power and peak time (time is calculated from the start of the second return).
- The half width based on the peak power.
- The centroid position as power and time (time is calculated from the start of the second return).
- The energy of the second return. Called the Ref. 2nd Return for the reference seafloor depth and Actual 2nd Return for the actual seafloor depth, in the energy results frame.
- The median power.

Statistics for Normalized Returns			
Moments for the First Return from the Start of the Return			
1st Moment	2nd Moment	3rd Moment	4th Moment
1.18	0.0167	0.000305	0.0000064
First Return Centroid		First Return Tail Centroid	
Power	Time	Power	Time
1.22	0.00821	0.423	0.0152
Second Return Centroid		Moment Coefficients	
Power	Time	Standard Deviation	Skewness
0.113	0.00553	0.0839	0.0865
Statistics		Kurtosis	
First Return Peak Power	First Return Peak Time	0.0247	
7.16	0.0694		
Energy Results			
Second Return Peak Power	Second Return Peak Time	Tail 1st Return	Actual 2nd Return
0.333	0.144	0.213	0.0113
First Return Half Width	Second Return Half Width	Tail Ref 1st Return	Ref 2nd Return
0.0032	0.00107	0.0161	0.000855
Median Powers			
First Return	Second Return		
0.385	0.0208		

Figure 10 : Statistics Form

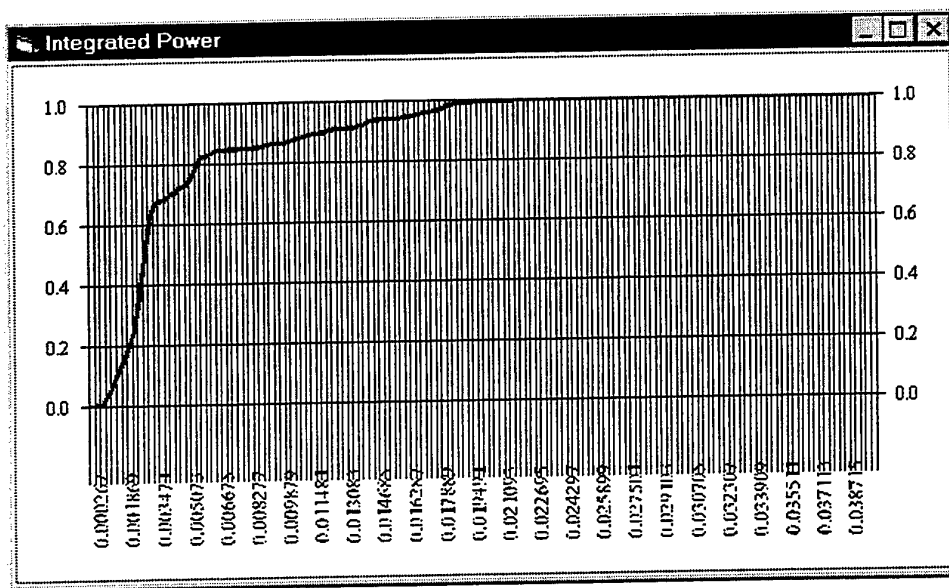

Figure 11 : Integrated Power Plot. Normalised Power² vs Time (sec) for the whole of the first return.

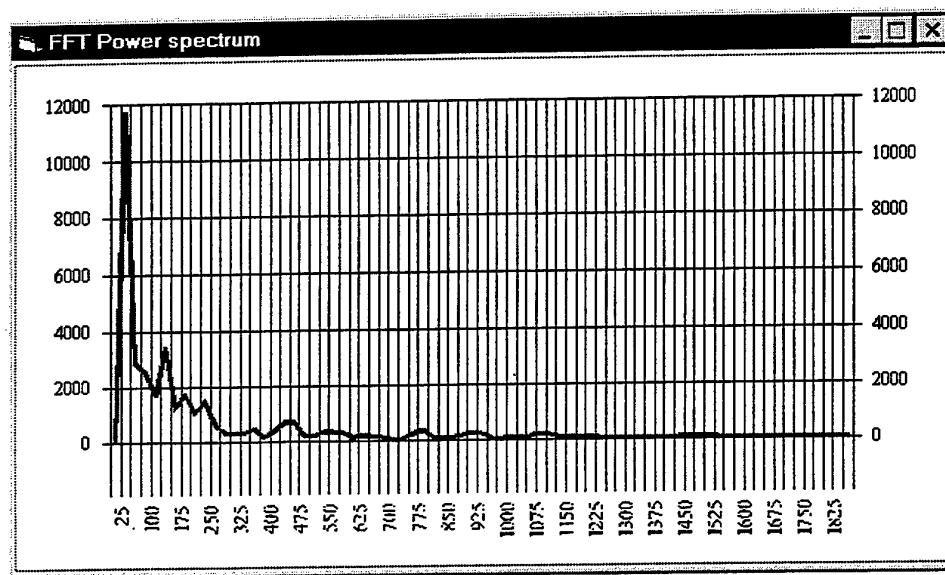

Figure 12 : FFT Plot. Power vs Frequency (Hz) for the whole of the first return.

3.4 Problems found from Analysing Test Data

The digitised test data is mostly at zero amplitude when an echo is not being heard. This shows that the Echo Listener™ is not recording the background noise, and thus producing an artificially higher noise floor. The cause of this is probably the lack of dynamic range when the depth sounder signal is being digitised. The current echo listener has a 12 bit A/D converter, which must be able to convert the ringing at the start of the signal without an over load, and thus is not recording low power signals.

The start and end points of the second return are currently not being found on a high percentage of pings. This is due to the low power levels returned to the hydrophone from the second return. Since the Echo Listener is currently producing an artificial high noise floor, this problem could cease when the artificial noise floor is removed. So no work has been done to remove this problem in the current version of ABCS, and this should be looked at when there is a better signal to noise ratio for the second return.

The Echo Listener currently being used was designed to record only the first return, which is why it only has a 12 bit A/D converter. This can be used to do acoustic bottom classification, since the QTC System uses only data from the first return to do its classification.

The Echo Listener design is currently being updated by Sonar Data to give it an extra 15 dB dynamic range. Sonar Data have tested prototypes of the new design and are currently having the new circuit boards engineered (Higginbottom 1999). This new model should remove the artificial noise floor and enable the second return to be found.

4. Conclusions

The current version of the ABCS program has manual checking for the start and end points of the echo sounder returns. The first returns are normally found correctly after one three point smoothing of the raw data, but are sometimes successfully found with no smoothing. The second return is normally not found, due to a low signal to noise ratio of this return, caused by the Echo Listener™ currently being used (see 3.4 Problems found from Analysing Test Data). This problem can either be fixed or the second return ignored. The first return has enough data to determine the acoustic bottom classification, since QTC™ uses only the first return in its classification.

When the digitised echo sounder signal has a higher dynamic range or it is decided to ignore the second return, raw data should be obtained at a number of sites where the sediment type is known. This data can then be used to refine the ABCS program, so that the finding of the returns can be totally automated, without the need to check if the returns were found correctly. Also a format for the statistical data produced can be decided and the analysis of these statistics begun.

5. References

- D.R Burns, C.B. Queen, H. Sisk, W. Mullarkey, and R.C. Chivers (1989)
Rapid and convenient acoustic sea-bed discrimination for fisheries applications. Proceedings of the Institute of Acoustics, 11, Part 3, 169-178
- D. Cato, G. Steward, A. Jones, C. Norwood, S. Taylor, J. Riley, D. Liebing, A. Madry, R. Wilkinson, and I. Jones (1995)
Basics of Under Water Acoustics. Course notes. Acoustics and Vibration Centre University of New South Wales and Australian Defence Force Academy. (Unpublished).
- D. A. Caughey and R. L. Kirilin (1996)
Blind Deconvolution of Echo Sounder Envelopes, Presented ICASS 96. 1996 International Conference on Acoustics, Speech and Signal Processing, page 3150. May 7-10. 1996. Marriott Marquis Hotel, Atlanta, Georgia. Institute of Electrical and Electronics Engineers Signal Processing Society.
- D. Caughey, B. Prager, and J. Klymak (1994)
Sea Bottom Classification from Echo Sounding Data. Contractor's Report 94-56. Document number SC93-019-FR-001. Quester Tangent Corporation, Marine Technology Centre, 99-9865 West Saanich Road, Sidney, British Columbia, V8L 3S1. 35pp

R.E. Francois and G.R. Garrison (1982)

Sound absorption based on ocean measurements: Part I: Pure water and magnesium sulfate contributions. J. Acoust. Soc. Am. 72(3), 896-907

S.L. Grossman (1984)

Calculus. Third edition. International edition. Academic Press Inc.

G.J.Heald and N. G. Pace (1996)

An Analysis of 1st and 2nd Backscatter for Seabed classification. To be published in the 3rd European Conference on Underwater Acoustics.

Higginbottom I. (1999)

Personal correspondence with L. Hamilton 29 June 1999.

X. Lurton and E. Pouliquen (1992)

Automated Sea-Bed Classification System for Echo Sounders. Laboratoire d'Acoustique Sous-Marine, IFREMER, Centre de BREST, BP 70, 29820 PLOUZANE, FRANCE, IEEE Oceans 1992 Conference Proceedings , 317-321

B.T. Prager, D.A. Caughey, and R.H. Poeckert (1995)

Bottom classification: operational results from QTC View. " OCEANS' 95 - Challenges of our Changing Global Environment " Conference, San Diego, California, USA. October 1995.

J. G. Proakis and D. G. Manolakis (1989)

Introduction to digital signal processing. MacMillan Publishing Company. New York.

M.R. Spiegel (1972)

Theory and Problems of Statistics. SI metric edition. Schaums Outline Series. McGraw-Hill Book Company. 359pp.

Appendix 1: Returned Ping Shape and Energy Variations with Seafloor Depth

The shape and energy of the returned signal can change significantly with seafloor depth (see Figure 13) as a result of ping dilation or compression, spreading losses, and absorption.

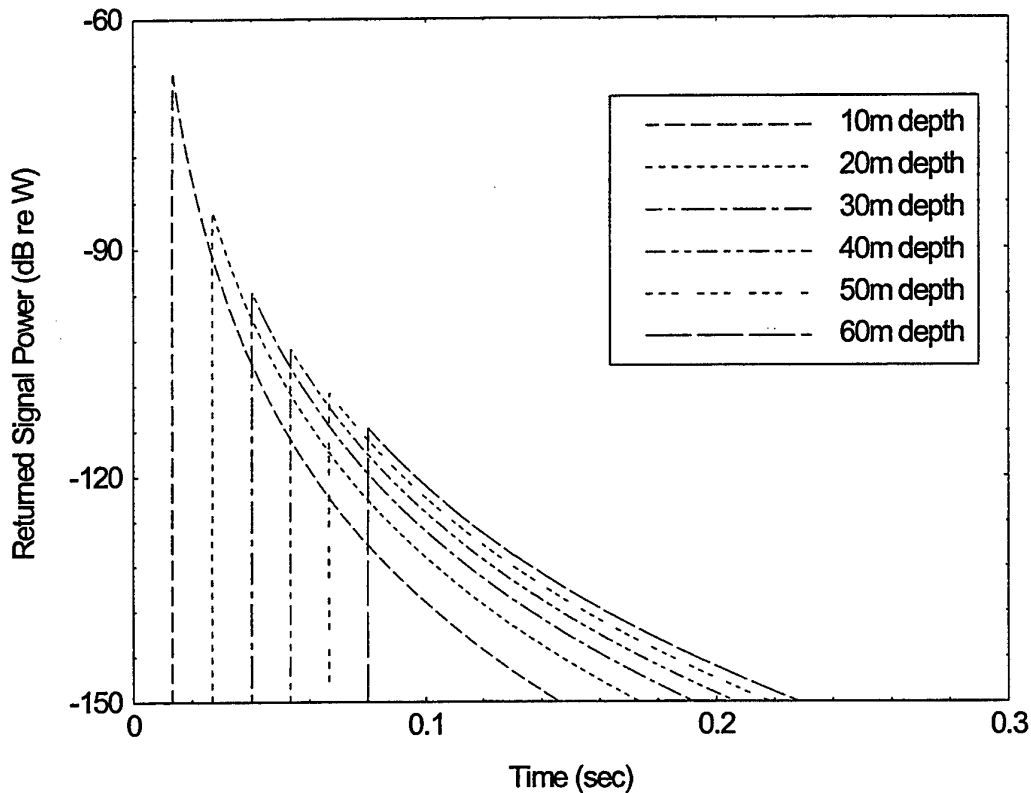

Figure 13: How seafloor depth effects the returned signal. Calculated using Levels.

Ping Dilation or Compression

When the depth of water changes, the start time of the returned ping changes along with the duration of the ping. The changing of the duration of the returned ping is called ping dilation or compression, depending on whether the ping's duration has increased or decreased.

To see how the returned ping can change duration as the seafloor depth differs, consider the same source ping insonifying the seafloor at two different depths to an angle of 2θ (see Figure 14). The wave fronts produced by the source will be spherical in shape. The leading edge of the ping will be insonifying the seafloor at an angle θ and there will be some point (point A in Figure 14) in the source ping that is just about to start insonifying the seafloor, with time between these two points being δt .

Since
 $\delta t_1 = c \delta r_1$, $\delta t_2 = c \delta r_2$ eq(7)

and
 $\delta r_1 = \frac{d_1}{\cos\theta} - d_1$, $\delta r_2 = \frac{d_2}{\cos\theta} - d_2$ eq(8)

where c = radial speed of sound
 δr = the distance between the points
 d = depth

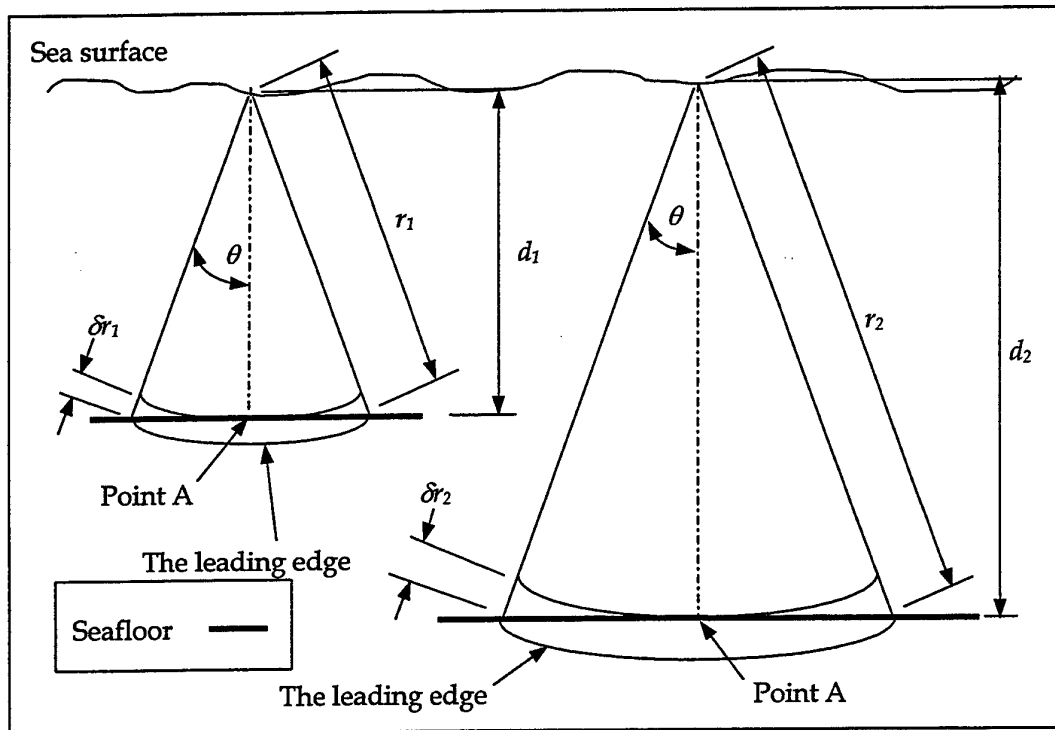

Figure 14: Two different depths with the same insonified angle, when the insonified area is a circle.

Combining eq(7) and eq(8) gives:

$$\delta t_2 = \frac{d_2}{d_1} \delta t_1 \quad \text{eq(9)}$$

Therefore the time taken to insonify the seafloor to a specific angle after the start of the ping first hits the seafloor takes longer for deeper water. The return path back to the hydrophone will have a similar delay. For a constant sampling rate, more samples will be taken before a particular angle is reached for a deeper bottom compared to a shallower bottom. Therefore the deeper the water the longer the duration of the returned pulse (see Figure 15). This result also holds for an insonified annulus on the seafloor.

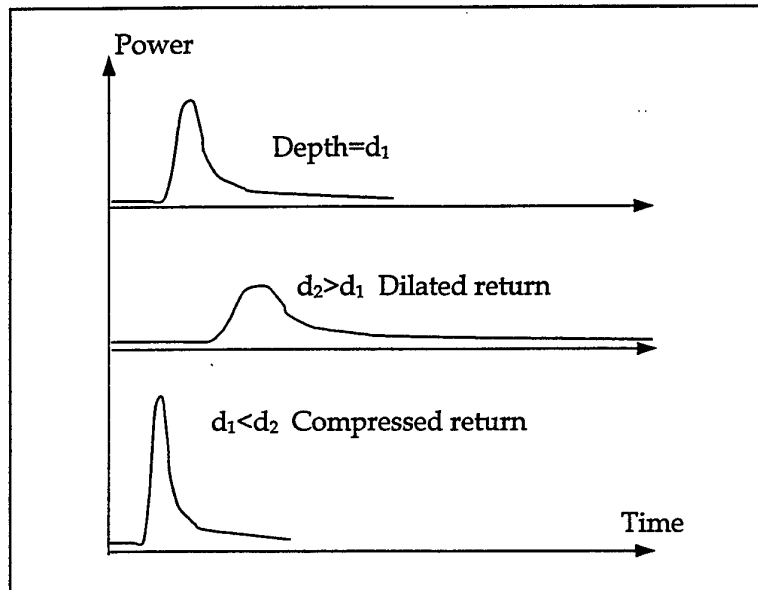

Figure 15: Ping variations due to seafloor depth changes. d_1 is the reference seafloor depth and d_2 is the new seafloor depth

Spreading Losses and Absorption

An echo sounder ping experiences only significant spherical spreading loss, due to the short distance over which it operates. Since spherical spreading is dependent on distance the amount of spreading loss will vary depending on depth.

The absorption of an echo sounder ping occurs as it passes through the water. The amount of absorption is dependent on the distance travelled through the water, and the temperature, salinity, and pressure of the water. Therefore as the seafloor depth changes the amount of absorption will change, but since the amount of absorption occurring in the distances travelled by the first two returns of an echo sounder ping is small³, the effect of absorption is minimal.

³ For a temperature of 20 °C, salinity of 35, and depth of 10 m, the absorption at 10, 30, 50, and 100 kHz is 0.761, 5.19, 13.0, and 38.0 dB/km respectively (from Francois and Garrison 1982)

DSTO-GD-0215

Appendix 2: Geometric Errors when Converting to a Reference Seafloor Depth

Consider a ping of duration Δt coming from an omnidirectional source. This energy will radiate out from the source hitting the seafloor, and some of the energy will then be backscattered back to the hydrophone. Since the energy emitted from the source will be spherical in shape and only Δt in duration, some of the beam will first insonify a circle on the seafloor. The circle will widen with time until the end of the ping reaches the seafloor. Then an insonified annulus will form on the seafloor, which will move out radially from the centre.

To show how the geometric errors occur, consider an insonified annulus on the seafloor with a reference seafloor depth of 50 m and an actual seafloor depth of 100 m which is transformed to the reference seafloor depth.

Using a realistic case where the ping duration $\Delta t = 2$ msec, $\theta = 30^\circ$, and the speed of sound $c = 1500$ m/s (see Figure 21).

For the 100 m case:

Since $\text{Cos } \theta = \frac{2d}{ct}$ (eq(36) appendix 4), therefore $t=0.15396$ sec at 100 m.

Also $\text{Cos}(\theta - \Delta\theta) = \frac{2d}{c(t - \Delta t)}$ (eq(37) appendix 4)

This gives $\Delta\theta = 1.33^\circ$ at 100 m

If this was transformed to the reference seafloor depth of 50 m using $t' = \frac{d_0 t}{d}$ the time would become $t' = 0.07698$ sec, but θ and $\Delta\theta$ would still be 30° and 1.33° respectfully. This gives an insonified area of 236 m^3 at the reference seafloor depth.

For the 50 m case:

The time t would equal 0.07698 sec, but the ping duration Δt would still be 2 msec. Doing the above calculation again gives $\Delta\theta = 2.76^\circ$ and an insonified area of 477 m^3 .

This shows that the size of the insonified annulus on the seafloor is significantly different when comparing the 100 m seafloor depth adjusted to the 50 m with the reference seafloor at 50 m depth.

DSTO-GD-0215

Appendix 3: The 'Levels' Program

The Levels program was written to calculate the expected first return from any shaped source ping envelope. The return could then be transformed to a reference depth to give an idea of how well a specific transform is working. The ping envelope shape used to simulate the Furuno echo sounder was a 2 msec half sine wave envelope (see Figure 2).

Since any source can be made up from a number of piece-wise constant power inputs of varying amplitude (see Figure 2), and the return from a constant power source can be calculated using just two equations (see appendix 4 for the derivation of the two equations below), the program was written to calculate the return using this method.

The two equations used were:

$$R = \frac{P\beta}{6d^2} \left(1 - \left(\frac{2d}{ct} \right)^3 \right)$$

which is used when $\frac{2d}{c} \leq t \leq \frac{2d}{c} + \Delta t$ (eq(28) and eq(31), appendix 4)

And

$$R = \frac{4P\beta d}{3c^3} \left(\frac{1}{(t - \Delta t)^3} - \frac{1}{t^3} \right)$$

which is used when $t \geq \frac{2d}{c} + \Delta t$ (eq(38) and eq(39), appendix 4)

where d = Depth to the seafloor.

c = Sound speed in the water.

t = Time since the start of the constant power input was produced by the source.

P = Power coming from the omnidirectional source.

R = Power received by the hydrophone.

β = The backscatter ratio.

Δt = The duration of the constant power input.

The levels program uses the above two equations to calculate the return for one constant power input of duration Δt (see Figure 16). It then simulates the return for the whole ping by adjusting the amplitude and doing a time shift of Δt for each of the constant power inputs which make up the ping (see Figure 2). All the inputs are then added to give the returned signal (to give a better idea of how the inputs are added the first four input returns are shown in Figure 17).

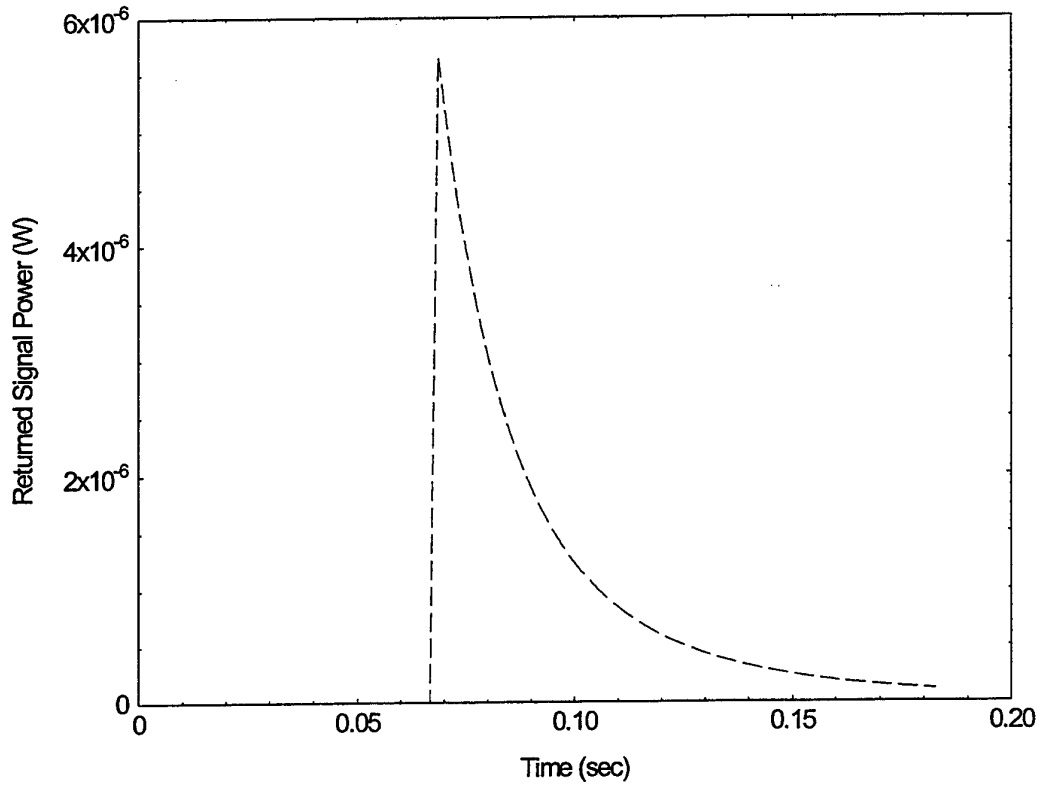

Figure 16: The returned signal at a depth of 50 m for one constant power input.

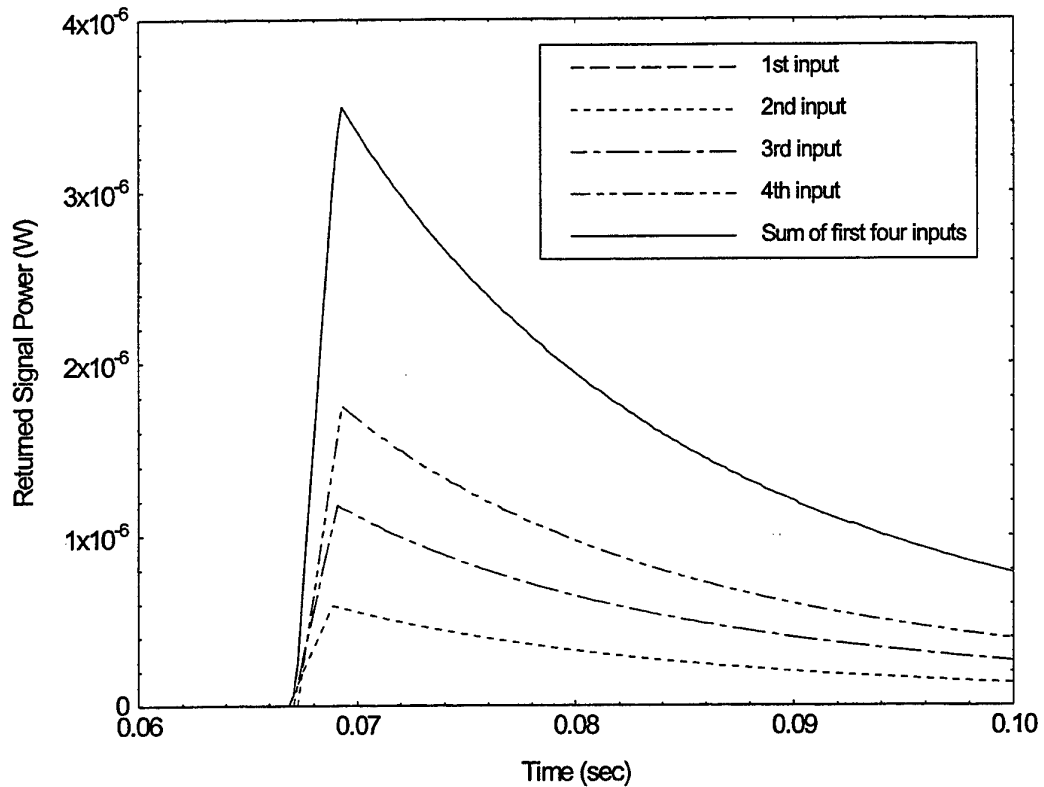

Figure 17: Summing the first four constant power inputs for the sine wave used (see Figure 2). There are more inputs to simulate the whole sine input, but these were left out so the graph is not too complicated. Each input had a duration $\Delta t = 0.01$ msec. Input 1 had zero amplitude. Input 2 had a time shift of Δt . Input 3 had a time shift of $2\Delta t$. Input 4 had a time shift of $3\Delta t$.

When calculating the returns the following assumptions were made:

- The seafloor is flat.
- The backscatter strength is constant with angle.
- An omnidirectional source and receiver.

Thus any plots produced by this program will have these assumptions.

Appendix 4: Calculation of the Power Returned from a Constant Power Input

Consider a constant power ping of duration Δt coming from an omnidirectional source. This energy will radiate out from the source hitting the seafloor, and some of the energy will then be backscattered back to the hydrophone. Since the energy emitted from the source will be spherical in shape and only Δt in duration, some of the beam will first insonify a circle on the seafloor. The circle will widen with time until the end of the ping reaches the seafloor. Then an insonified annulus will form on the seafloor, which will move out radially from the centre.

Calculation of the Power in a Beam from an Omnidirectional Source

Consider the energy emitted from the omnidirectional source of constant power and a ping duration of Δt . This energy will radiate away from the source forming a spherical shell of width Δt and radius b (assuming a constant sound speed in the water). The power level emitted by the source will be equal to the total power over the surface area of the sphere. Since the source is omnidirectional the power will be evenly distributed over the sphere.

$$P_s = \frac{P}{4\pi b^2} \quad \text{eq(10)}$$

where P_s = Power level per unit area over the sphere.

b = Radius of the sphere.

P = Power level emitted from the source.

Therefore the power level in a beam of half width ξ (see Figure 18) will be:

$$B = P_s \sigma \quad \text{eq(11)}$$

where B = Power level in the beam.

σ = Surface area of the spherical beam at radius b , with half width ξ .

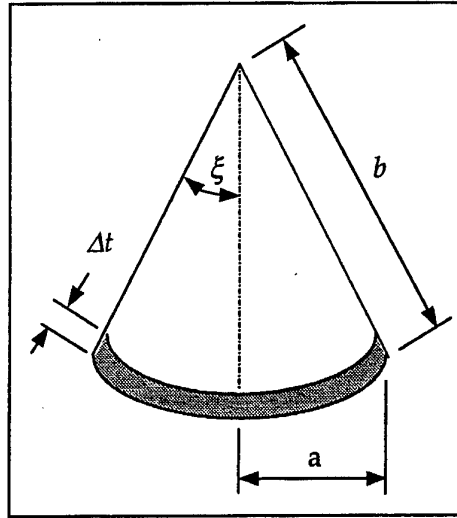

Figure 18: Beam of half width ξ and duration Δt .

The equation describing the spherical beam is:

$$z^2 = b^2 - x^2 - y^2 \quad \text{eq(12) (see Figure 18)}$$

The surface area (σ) of the spherical beam of half width ξ will be:

$$\sigma = \iint_{\Omega} \sqrt{1 + f_x^2 + f_y^2} dA \quad \text{eq(13) (Grossman 1984)}$$

where Ω = The region defining the beam at radius b

$$f_x^2 = \frac{x^2}{b^2 - x^2 - y^2}$$

$$f_y^2 = \frac{y^2}{b^2 - x^2 - y^2}$$

Therefore

$$\sigma = \iint_{\Omega} \sqrt{\frac{b^2}{b^2 - x^2 - y^2}} dA \quad \text{eq(14)}$$

Substituting $y = \mu \sin \omega$ and $x = \mu \cos \omega$ gives:

$$\sigma = \int_0^a \int_0^{2\pi} \mu \sqrt{\frac{b^2}{b^2 - \mu^2}} d\omega d\mu \quad \text{eq(15)}$$

where μ = Distance from the z axis
 ω = Angle from the x axis, centred on the z axis
 ie. a cylindrical coordinate system

Solving this gives:

$$\sigma = 2\pi b \left(b - \sqrt{b^2 - a^2} \right) \quad \text{eq(16)}$$

Since $a = b \sin \xi$ (see Figure 18) therefore:

$$\sigma = 2\pi b^2 (1 - \cos \xi) \quad \text{eq(17)}$$

Combining eq(10), eq(11), and eq(17) gives:

$$B = \frac{P}{2} (1 - \cos \xi) \quad \text{eq(18)}$$

where P = The power level emitted by the source.
 B = The power level of a beam of half width ξ .

Calculating the Insonified Circle Power Backscattered.

An insonified circle on the seafloor will exist from the time the front of the ping first reaches the seafloor, until the end of the ping reaches the seafloor.

$$\text{ie. when } \frac{d}{c} \leq t \leq \frac{d}{c} + \Delta t \quad \text{eq(19)}$$

where d = Depth to the seafloor.

c = Sound speed in the water.

t = Time since the start of the ping was produced by the source.

Δt = The duration of the ping.

assuming a constant sound speed and a flat seafloor.

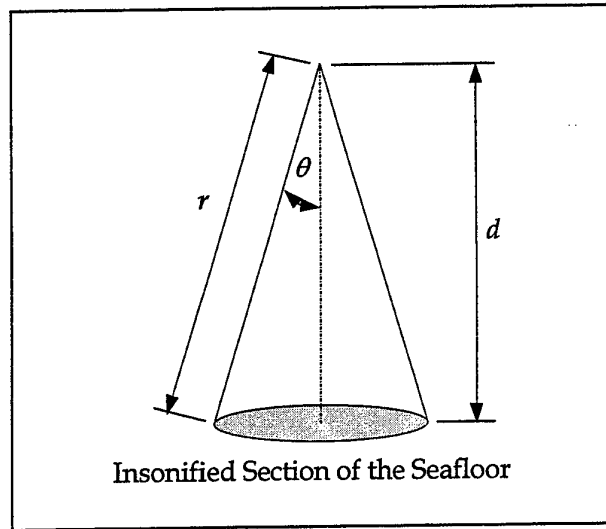

Figure 19: Insonified circle on the Seafloor

The level of insonification in the circle (shown in Figure 19) will be equal to the power in the angular beam of width 2θ which produced the circle.

Therefore the level of insonification in the circle will be:

$$B = \frac{1}{2}(1 - \cos \theta)P \quad \text{eq(20) (from eq(18))}$$

where P = Power level of the ping coming from the source.

B = Level of insonification in the circle. (see Figure 19)

Since a spherical coordinate system was used to calculate eq(20), spherical spreading has already been considered⁴.

The size of the insonified circle increases with time (ie. θ will increase with time), but only exists between the two constraining times (eq (19)). The level of insonification will vary over the circle, with the strongest insonification in the centre of the circle.

Since eq(20) is the level of insonification in the circle, and the circle is increasing in diameter with time, $\frac{dB}{d\theta}$ will equal the level of insonification at the outside edge of the insonified circle (this is only true for a constant power ping, since it requires that any point in the insonified circle have a constant insonification level with time).

⁴ For a constant angle beam, the amount of energy in the beam will be constant if there is no absorption in the water. This is because the diameter of the beam increases with range at the same rate as the signal at any one point decreases.

$$\frac{dB}{d\theta} = \frac{P}{2} \sin\theta \quad \text{eq(21)}$$

Therefore the power level emitted by an insonified ring towards the source will be:

$$\frac{P\beta}{2} \sin\phi \cdot d\phi \quad \text{eq(22) (see Figure 20)}$$

where β = The backscatter ratio.

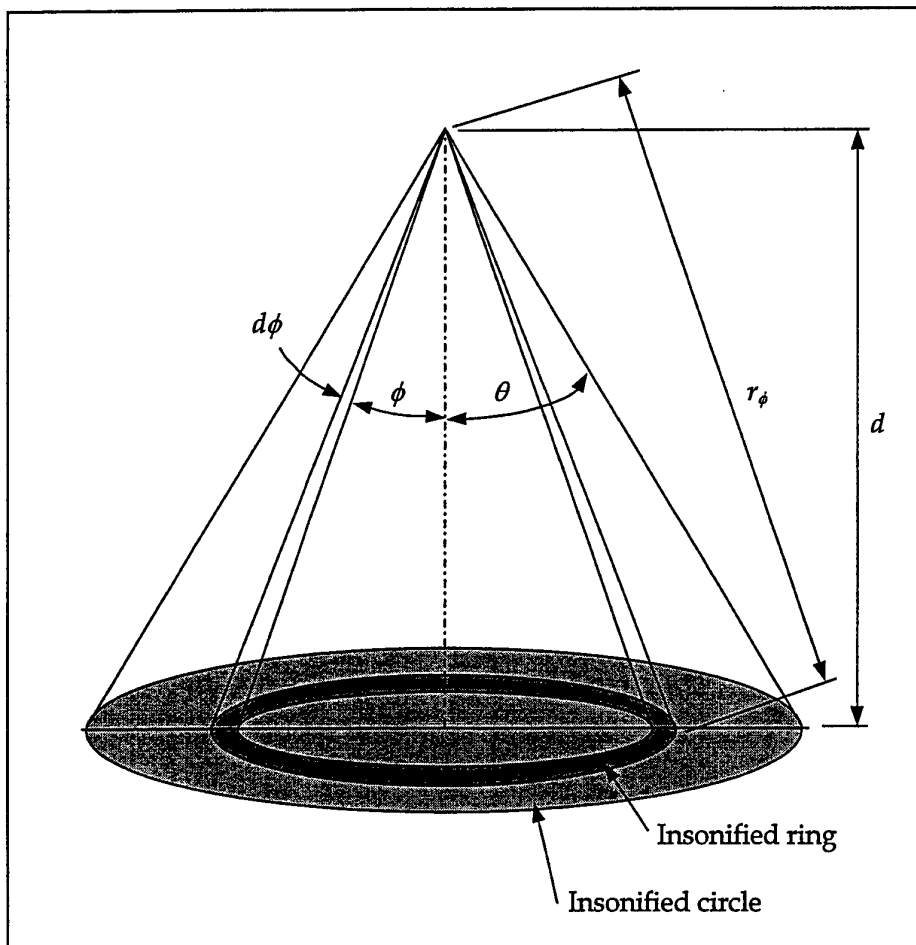

Figure 20: Insonified ring on the seafloor.

Summing the effect of all the rings and correcting for spherical spreading gives the power level backscattered by the insonified circle (see Figure 20) to the hydrophone at any one time:

$$R = \int \frac{P\beta}{2} \frac{1}{r_\phi^2} \sin\phi \cdot d\phi \quad \text{eq(23)}$$

where R = Power level received at the hydrophone.

$$\text{Since } \frac{1}{r_\phi^2} = \frac{\cos^2\phi}{d^2} \quad \text{eq(24) (see Figure 20)}$$

Therefore

$$R = \int \frac{P\beta}{2d^2} \sin\phi \cdot \cos^2\phi \cdot d\phi \quad \text{eq(25)}$$

Assuming the backscatter ratio is constant with incident angle gives;

$$R = \frac{P\beta}{2d^2} \int \sin\phi \cdot \cos^2\phi \cdot d\phi \quad \text{eq(26)}$$

Therefore

$$R = \frac{P\beta}{6d^2} (1 - \cos^3\theta) \quad \text{eq(27)}$$

This signal would arrive at the hydrophone between the times;

$$\frac{2d}{c} \leq t \leq \frac{2d}{c} + \Delta t \quad \text{eq(28)}$$

$$\text{Since } \cos\theta = \frac{d}{r} \quad \text{eq(29)}$$

$$\text{and } r = \frac{ct}{2} \quad \text{eq(30)}$$

where r = The distance travelled by the start of the ping to the seafloor (see Figure 19).

t = The travel time to the seafloor and back to the hydrophone.

Therefore the power level received by the hydrophone at any instant during the times specified by eq(28) will be;

$$R = \frac{P\beta}{6d^2} \left(1 - \left(\frac{2d}{ct} \right)^3 \right) \quad \text{eq(31)}$$

where t = Time the backscattered signal is received by the hydrophone.

Calculating the Insonified Annulus Power Backscattered.

The annulus will exist just after the end of the ping reaches the seafloor, leaving a circle in the centre that is no longer insonified.

ie. when $t \geq \frac{d}{c} + \Delta t$ eq(32)

where d = Depth to the seafloor.

c = Sound speed in the water.

t = Time since the start of the ping was produced by the source, assuming a flat seafloor.

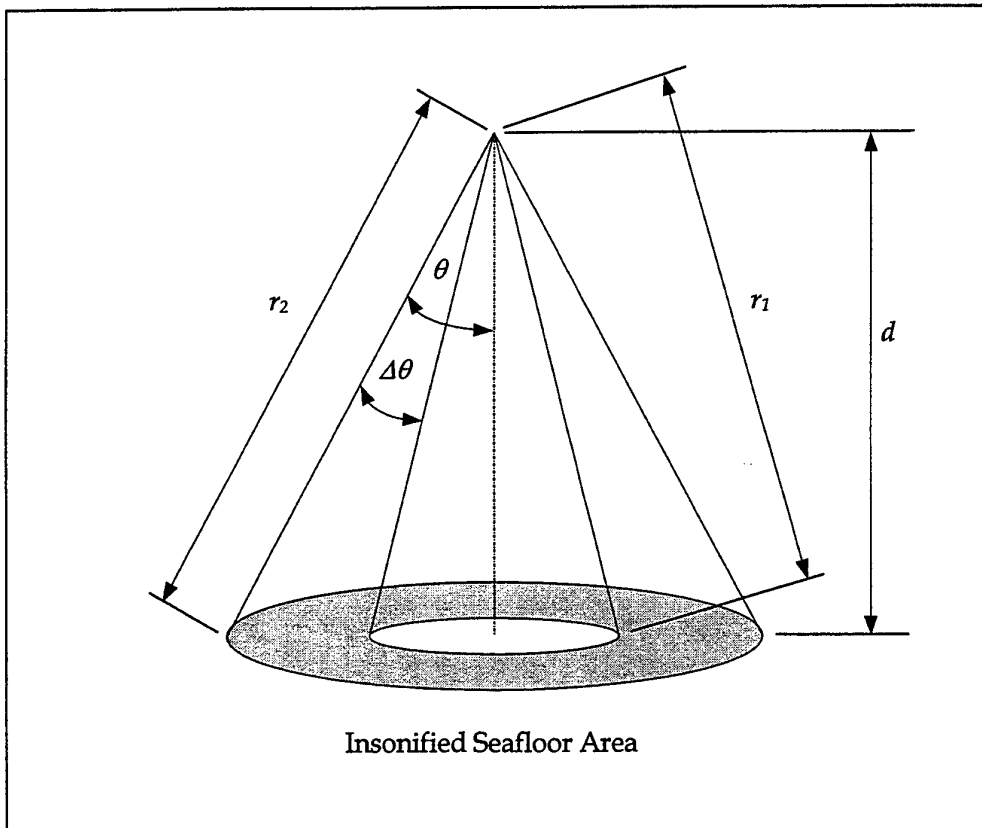

Figure 21: Insonified Annulus on the seafloor.

r_1 = The distance travelled by the end of the ping to reach the seafloor.

r_2 = The distance travelled by the start of the ping to reach the seafloor

The power backscattered by the insonified annulus (see Figure 21) to the hydrophone at a time given by eq(32) will be;

$$R = \frac{P\beta}{2d^2} \int_{\theta-\Delta\theta}^{\theta} \text{Sin}\phi \cdot \text{Cos}^2\phi \cdot d\phi \quad \text{eq(33) (see eq(26))}$$

$$R = \frac{P\beta}{6d^2} \left((1 - \text{Cos}^3\theta) - (1 - \text{Cos}^3(\theta - \Delta\theta)) \right) \quad \text{eq(34)}$$

Therefore

$$R = \frac{P\beta}{6d^2} \left(\text{Cos}^3(\theta - \Delta\theta) - \text{Cos}^3\theta \right) \quad \text{eq(35)}$$

Since

$$r_2 = \frac{ct}{2}, \quad \text{Cos}\theta = \frac{d}{r_2}, \quad r_1 = \frac{c(t-\Delta t)}{2}, \quad \text{and} \quad \text{Cos}(\theta - \Delta\theta) = \frac{d}{r_1}$$

Therefore

$$\text{Cos}\theta = \frac{2d}{ct} \quad \text{eq(36)}$$

$$\text{and} \quad \text{Cos}(\theta - \Delta\theta) = \frac{2d}{c(t-\Delta t)} \quad \text{eq(37)}$$

Combining eq(35), eq(36), and eq(37) gives the power level returned to the hydrophone for an annulus.

$$R = \frac{4P\beta d}{3c^3} \left(\frac{1}{(t-\Delta t)^3} - \frac{1}{t^3} \right) \quad \text{eq(38)}$$

$$\text{which occurs when } t \geq \frac{2d}{c} + \Delta t \quad \text{eq(39)}$$

Appendix 5: Search Areas used by 'ABCS' to find the Seafloor Returns

The ABCS program uses the seafloor depth to calculate the expected regions in which the start and finish of the returns should be (see Figure 22). To find a start or end point the program looks for 4 consecutive points of increasing value in the expected regions.

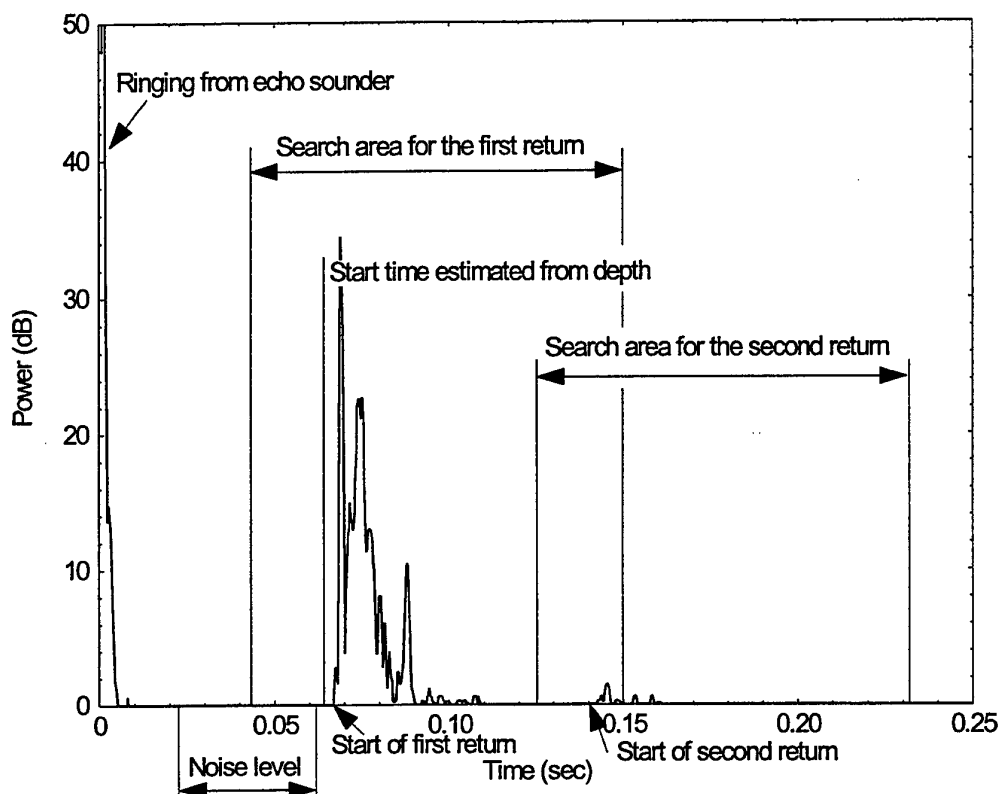

Figure 22: Areas searched by the ABCS program.

The first point searched for is the start of the first return. This search starts from $0.7 \times$ Start time estimated from the seafloor depth and goes along a time interval of the sample duration/5.0. The time estimated from the seafloor depth = $2 \times$ seafloor depth/sound speed. If the seafloor depth in this text box is off by a large amount the expected region might not contain the start point. If a start point is found, the seafloor depth is calculated from this, with all the other search regions using this new seafloor depth. If this start point is not found no other points are looked for.

The next point searched for is the start of the second return. This search starts at $1.9 \times$ Start of the first return and has a search duration of the sample duration / 5.0.

The end of the returns are looked for next, and are searched for in the reverse order. With these points the times searched depends on whether the second start point was found. If the second start point was found, the end of the first return is searched for between the two start points, and the end of the second return is searched from the end of the samples for the ping to the start of the second return. If the start of the second return is not found, the end of the first return is searched for from the end of the ping samples to the start of the first return, with no search for the second return end.

The background noise level is also calculated using the start time, this value is taken as an average of the points between the 80th sample and 0.9* the start time of the first return. The average is not taken from the first sample due to a ringing in the echo sounder appearing in the first few samples.

DISTRIBUTION LIST

The ABCS Program for the Analysis of Echo Sounder Returns for Acoustic Bottom
Classification

Paul A. Clarke and L. J. Hamilton

AUSTRALIA

DEFENCE ORGANISATION

Task Sponsor: MWSCPD, CP 2 - 2 - 19, Campbell Park, Canberra, ACT, 2600

S&T Program

Chief Defence Scientist
FAS Science Policy
AS Science Corporate Management
Director General Science Policy Development
Counsellor Defence Science, London (Doc Data Sheet)
Counsellor Defence Science, Washington (Doc Data Sheet)
Scientific Adviser to MRDC Thailand (Doc Data Sheet)
Scientific Adviser Policy and Command
Navy Scientific Adviser
Scientific Adviser - Army (Doc Data Sheet and distribution list only)
Air Force Scientific Adviser
Director Trials

} shared copy

Aeronautical and Maritime Research Laboratory

Director
Chief of Maritime Operations Division
Research Leader: Dr A. Theobald
Head: Dr D.H. Cato
Task Manager: Dr P.J. Mulhearn
Authors: Mr P. Clarke (5 copies)
 Mr L.J. Hamilton (5 copies)
Dr A.D. Jones, AMRL Salisbury

DSTO Library

Library Fishermens Bend
Library Maribyrnong
Library Salisbury (2 copies)
Australian Archives
Library, MOD, Pyrmont (2 copies)
Library, MOD, HMAS Stirling
*US Defence Technical Information Center, 2 copies
*UK Defence Research Information Centre, 2 copies
*Canada Defence Scientific Information Service, 1 copy
*NZ Defence Information Centre, 1 copy
National Library of Australia, 1 copy

Capability Development Division

Director General Maritime Development
Director General Land Development (Doc Data Sheet only)
Director General Aerospace Development (Doc Data Sheet only)
Director General C3I Development (Doc Data Sheet only)

Navy

SO (Science), Director of Naval Warfare, Maritime Headquarters Annex,
Garden Island, NSW 2000
COMAUSMINDIVFOR, HMAS Waterhen, Waverton, NSW, 2060
Director, Oceanography & Meteorology, Maritime Headquarters, Potts Point, NSW, 2011
Minehunter Coastal Project Director, Department of Defence, Campbell Park,
(CP2-3-16), CANBERRA, ACT, 2600
DDMWD, A - 3-02, Russel Offices, Canberra ACT 2600
SOMCD, DNW, Maritime Headquarters Annex, Garden Island, NSW 2000
OIC, Mine Warfare School, HMAS Waterhen, WAVERTON NSW 2060
OIC, Mine Warfare Diving School, HMAS Penguin, Balmoral Naval Post Office,
BALMORAL NSW 2091
Australian Project Officer, MWDDEA 5807/5819, Maritime Headquarters Annex,
Garden Island, NSW 2000
Officer in Charge, RAN Clearance Diving 1, HMAS Waterhen, Waverton, NSW 2060

Intelligence Program

DGSTA Defence Intelligence Organisation

Corporate Support Program (libraries)

OIC TRS, Defence Regional Library, Canberra

UNIVERSITIES AND COLLEGES

Australian Defence Force Academy
Library
Head of Aerospace and Mechanical Engineering
Serials Section (M list), Deakin University Library, Geelong, 3217
Senior Librarian, Hargrave Library, Monash University
Librarian, Flinders University

OTHER ORGANISATIONS

NASA (Canberra)
AGPS

OUTSIDE AUSTRALIA

ABSTRACTING AND INFORMATION ORGANISATIONS

Library, Chemical Abstracts Reference Service
Engineering Societies Library, US
Materials Information, Cambridge Scientific Abstracts, US
Documents Librarian, The Center for Research Libraries, US

INFORMATION EXCHANGE AGREEMENT PARTNERS

Acquisitions Unit, Science Reference and Information Service, UK

Library - Exchange Desk, National Institute of Standards and Technology, US

SPARES (5 copies)

Total number of copies: 69

DEFENCE SCIENCE AND TECHNOLOGY ORGANISATION DOCUMENT CONTROL DATA		1. PRIVACY MARKING/CAVEAT (OF DOCUMENT)		
2. TITLE The ABCS Program for the Analysis of Echo Sounder Returns for Acoustic Bottom Classification		3. SECURITY CLASSIFICATION (FOR UNCLASSIFIED REPORTS THAT ARE LIMITED RELEASE USE (L) NEXT TO DOCUMENT CLASSIFICATION) Document (U) Title (U) Abstract (U)		
4. AUTHOR(S) Paul A. Clarke and L.J. Hamilton		5. CORPORATE AUTHOR Aeronautical and Maritime Research Laboratory PO Box 4331 Melbourne Vic 3001 Australia		
6a. DSTO NUMBER DSTO-GD-0215	6b. AR NUMBER AR-011-033	6c. TYPE OF REPORT General Document	7. DOCUMENT DATE August 1999	
8. FILE NUMBER 9505/015/0170/01	9. TASK NUMBER M40 797	10. TASK SPONSOR MWSCPD	11. NO. OF PAGES 48	12. NO. OF REFERENCES 12
13. DOWNGRADING/DELIMITING INSTRUCTIONS		14. RELEASE AUTHORITY Chief, Maritime Operations Division		
15. SECONDARY RELEASE STATEMENT OF THIS DOCUMENT <i>Approved for public release</i>				
OVERSEAS ENQUIRIES OUTSIDE STATED LIMITATIONS SHOULD BE REFERRED THROUGH DOCUMENT EXCHANGE, PO BOX 1500, SALISBURY, SA 5108				
16. DELIBERATE ANNOUNCEMENT No Limitations				
17. CASUAL ANNOUNCEMENT Yes				
18. DEFTTEST DESCRIPTORS Shallow water, Sedimentation, Echo sounding, Waveforms, Underwater acoustics, Acoustic measurement, Sound transmission				
19. ABSTRACT An echo sounder can be used to indicate the type of sediment on the sea floor through analysis of the returned echo's shape and energy characteristics. This document describes the ABCS program written to analyse echosounder ping returns for simple shape and energy statistics, with the intention to investigate which statistics are important in characterising the seabed. ABCS was written in Visual Basic and can read in the data produced by the Echo Listener device manufactured by Sonar Data Tasmania. Also discussed in this paper is the need to transform all the data obtained to a reference seafloor depth and the method used by ABCS to do this.				