

DAAB07-97-C-6002

**SOLID HYDRIDE HYDROGEN SOURCE FOR
SMALL PROTON EXCHANGE MEMBRANE
(PEM) FUEL CELLS**

Werner F. Beckert, Ottmar H. Dengel
Royal Systems - 6294 Browntown Road, Front Royal , VA. 22630

Robert D. Lynch, Gary T. Bowman, Aaron J. Gresco
Atlantic Research Corp., 5945 Wellington Rd, Gainesville, VA 22065

Theodore A. Varouxis
Associated Design & Mfg. Co., 814 North Henry Street, VA 22314

Final Technical Report - Phase I SBIR

Period: October 1996 - May 1997

Approved for Public Release - Distribution is Unlimited

Prepared For:
United States Army Communication & Electronics Command
Research, Development & Engineering Center - South
10108 Gridley Road, Suite 1
Fort Belvoir, Va. 22060

DTIC QUALITY INSPECTED 4

19991202 060

REPORT DOCUMENTATION PAGE

Form Approved
OMB No. 0704-0188

Public reporting burden for this collection of information is estimated to average 1 hour per response, including the time for reviewing instructions, searching existing data sources, gathering and maintaining the data needed, and completing and reviewing the collection of information. Send comments regarding this burden estimate or any other aspect of this collection of information, including suggestions for reducing this burden, to Washington Headquarters Services, Directorate for Information Operations and Reports, 1215 Jefferson Davis Highway, Suite 1204, Arlington, VA 22202-4302, and to the Office of Management and Budget, Paperwork Reduction Project (0704-0188), Washington, DC 20503.

1. AGENCY USE ONLY (Leave Blank)		2. REPORT DATE May 1997	3. REPORT TYPE AND DATES COVERED Final Report October 1996 - May 1997	
4. TITLE AND SUBTITLE Solid Hydride Hydrogen Source for Small PEM Fuel Cells			5. FUNDING NUMBERS DAAB07-97-C-6002	
6. AUTHOR(S) Werner F. Beckert, Ottmar H. Dengel, Robert D. Lynch, Gary T. Bowman, Aaron J. Greso, Theodore A. Varouxis				
7. PERFORMING ORGANIZATION NAME(S) AND ADDRESS(ES) Royal Systems 6294 Browntown Road Front Royal, VA 22630			8. PERFORMING ORGANIZATION REPORT NUMBER RS-001	
9. SPONSORING/MONITORING AGENCY NAME(S) AND ADDRESS(ES) CECOM RD&E Center-South 10108 Gridley Road, Suite 1, AMSEL-RD-C2-PD-E Fort Belvoir, VA 22060-5817			10. SPONSORING/MONITORING AGENCY REPORT NUMBER	
11. SUPPLEMENTARY NOTES				
12a. DISTRIBUTION/AVAILABILITY STATEMENT Approved for public release, distribution unlimited			12b. DISTRIBUTION CODE	
13. ABSTRACT (Maximum 200 words) Report developed under SBIR contract 1. A solid reactant mixture was developed for incorporation in a prototype hydrogen gas generating (HGG) system. The reactant mixture consists of $1\text{NH}_4\text{Cl} + 3\text{LiAlH}_4 + 4\%\text{Fe}_2\text{O}_3$ and 4% Kraton. This mixture generates hydrogen with a yield of 7.7% hydrogen and forms a solid residue. 2. A concept for a prototype hydrogen gas generating (HGG) system was developed. The HGG system consists of a reaction chamber, a holding tank with associated valves, and a cartridge loaded with the reactant mixture, filter, and ignition system.				
14. SUBJECT TERMS SBIR Report Hydrogen Gas Generator, Fuel Cell			15. NUMBER OF PAGES	
			16. PRICE CODE	
17. SECURITY CLASSIFICATION OF REPORT Unclassified	18. SECURITY CLASSIFICATION OF THIS PAGE Unclassified	19. SECURITY CLASSIFICATION OF ABSTRACT Unclassified	20. LIMITATION OF ABSTRACT Unlimited	

PREFACE

This is the final report covering the efforts of Royal Systems in accordance with SBIR Phase 1 Contract DAAB07-97-C-6002.

This effort was conducted under the technical direction of Edward Starkovich, C2SID, the designated COTR. His support and advise were very helpful and are greatly appreciated.

The project was executed and managed by Royal Systems with Ottmar H. Dengel as principal investigator and project coordinator, and Werner F. Beckert as principal scientist.

The investigators under subcontract at Atlantic Research Corporation were Robert D. Lynch and Gary T. Bowman.

The investigator under subcontract at Associated Design & Manufacturing Co. was Theodore A. Varouxis.

Contents

I.	Introduction	5
II.	Background	6
III.	Summary	7
IV.	Hydrogen Storage and Generation Methods	9
	1. Pressurized hydrogen stored in gas cylinders or adsorbed/desorbed from suitable materials	9
	2. Wet hydrogen-generating systems	10
	3. Solid-state hydrogen-gas-generating systems	10
	A. Hydrogen generation based on the decomposition of hydrogen-rich compounds	10
	• Ammonium octahydrotriborate	11
	• Ammonia borane	11
	• Diborane diammoniate	12
	• Ammonia triborane	12
	• Hydrazine bisborane	12
	• Magnesium borohydride diammoniate	12
	B. Hydrogen generation based on the reactions between hydrogen-rich compounds	13
V.	Technical Approach	14
	• Selection of reactant mixture	14
	• Specific requirements	15
	• Thermal stability	16
	• Thermochemical calculations	16
	• DSC Testing of promising mixtures	17
	• Chemistry	18
	• Hydrogen yields	18
	• Binder usage	19
	• Burning rate modifiers (catalysts)	19
	• Burning rates	19
	• Grain design	20
	• Clinker formation	20
	• Disposal of spent cartridges	20
	• Safety test results	21
VI.	Recommended Formulation for Prototype Demonstration	22
VII.	Hydrogen Gas-Generator System	23
VIII.	Areas of Future Developmental Work to Achieve Higher Yields	25
IX.	References	26-27
X.	Figures	28-41
XI.	Tables	42-46

List of Figures

Figure 1.	DSC of LiBH_4	31
Figure 2.	DSC of LiAlH_4	32
Figure 3.	DSC of NaAlH_4	33
Figure 4.	DSC of $\text{NH}_4\text{Cl} + \text{LiAlH}_4$ at $10^\circ\text{C}/\text{min}$	34
Figure 5.	DSC of $\text{NH}_4\text{Cl} + \text{LiAlH}_4$ at $1^\circ\text{C}/\text{min}$	35
Figure 6.	Hydrogen Yield versus Thermal Stability	36
Figure 7.	DSC of $\text{NH}_4\text{Cl} + 3\text{LiAlH}_4 + 4\%\text{Fe}_2\text{O}_3 + 4\%$ Kraton	37
Figure 8.	TGA of $\text{NH}_4\text{Cl} + 3\text{LiAlH}_4 + 4\%\text{Fe}_2\text{O}_3 + 4\%$ Kraton	38
Figure 9.	DTA of $\text{NH}_4\text{Cl} + 3\text{LiAlH}_4 + 4\%\text{Fe}_2\text{O}_3 + 4\%$ Kraton	39
Figure 10.	DTA of $\text{NH}_4\text{Cl} + 3\text{LiAlH}_4 + 4\%$ Kraton (no Fe_2O_3)	40
Figure 11.	Hydrogen Gas-Generating System	41
Figure 12.	Design of Reactant Cartridge	42
Figure 13.	Engineering Drawing of Reaction Chamber	43
Figure 14.	Hydrogen Gas-Generating System -- System Weight versus Reactant Weight	44

List of Tables

Table I. Properties of Hydrogen Generating Compositions	45
Table II. Physical Constants used for Calculations	46
Table III. Calculated Values for Formulations under Consideration	47
Table IV. Hydrogen Gas-Generating Composition - Computer Calculation of Products	48
Table V. Weight Relationship for Reaction Chamber and Holding Tank	49

I. Introduction

Methods for hydrogen generation have been proposed, studied, and developed for a variety of applications, ranging from industrial uses, e.g., in the petrochemical industry, to hydrogen-fueled rockets and cars, to military applications, such as balloon inflation, hyper-velocity guns, and use of hydrogen and deuterium in chemical laser weapons. Obviously, the intended uses of the hydrogen restrict the generation methods that are feasible for specific applications.

The Communications-Electronics Command (CECOM) of the Department of the Army issued a request for proposal to develop a compact, lightweight, rechargeable hydrogen supply system for small proton exchange membrane (PEM) fuel stacks. The specific military use of the fuel-cell power system would be to replace the BA 5590 battery in long missions where high power demand must be met. More specifically, the hydrogen supply system should be capable of delivering clean hydrogen at rates up to 10g(5 moles/110L) per hour; delivering 10% hydrogen by weight (based on the system weight); and delivering a total of from 10g to 120g (60 moles/1340L) hydrogen.

II. Background

The most important conventional and some more exotic methods to generate relatively small amounts of hydrogen are discussed below, while considering the following special requirements dictated by the intended uses of the hydrogen gas-generating systems (HGGS):

- (1) The hydrogen yield of the formulation should be as high as possible. The goal is to generate 10% hydrogen by weight, based on the total weight of the HGGS.
- (2) The reactant mixture must meet military specifications as to thermal stability, that means, the hydrogen-generating grain must be stable to at least 75°C to meet these requirements.
- (3) The burning rate of the grain should be relatively slow, that means, in the range of fractions of an inch per second. A burning rate close to deflagration or explosion would require the addition of substantial additional safety features to the HGGS.
- (4) The HGGS should have a long shelflife.
- (5) No unacceptable risks should hamper production of the HGGS and its components.
- (6) The HGGS and its components must meet military safety requirements (friction, impact, electrical discharge tests, etc.).
- (7) The generated hydrogen gas should not contain any ammonia, carbon monoxide, or sulfur compounds, since these gases will deactivate the fuel cells. Water vapor, carbon dioxide, nitrogen, and other inert gases will act as undesirable diluents. These gas purity requirements were specified at a meeting on 11/22/96 between CECOM and Royal Systems representatives.
- (8) The generated hydrogen gas should not contain particulates, because they clog up the fuel cells and inactivate them. This requirement was also specified at the meeting on 11/22/96.
- (9) The hydrogen-generating reaction must be easy to start and must sustain itself without external energy supply, i.e., the overall reaction must be exothermic. The reaction temperature should be as low as possible in order to keep the hydrogen gas temperature and the total HGGS temperature acceptable. On the other hand, if a self-sustaining reaction should proceed in a mixture or chemical compound that is thermally stable up to, for example, 120°C, then the reaction temperature will, by necessity, be substantially higher than the temperature at which it fails the temperature stability test.
- (10) The disposal of the spent cartridges should pose no unacceptable environmental problem.
- (11) Size and volume of the HGGS have not been specified, but it is obvious from the intended application that both should be as small as possible. This rules out voluminous and heavy filtering and cooling arrangements for the gas stream.
- (12) Cost of the hydrogen-generating mixture and of the total HGGS should be kept as low as possible.

III. Summary

The goal of this effort was to develop a conceptual design of a hydrogen delivery system with a 10% hydrogen yield by system weight.

Hydrogen gas-generating reactant mixtures were prepared and tested, and hardware for the hydrogen gas-generator system was designed.

(1) Hydrogen gas-generating reactant mixture

Twenty-six different reaction scheme families were considered for evaluation. The available data of all promising compounds or mixtures of compounds published in the literature were carefully reviewed for thermal stability and other pertinent information. For some compounds, which are commercially available, small samples were prepared and tested for thermal stability. Unfortunately, several potentially promising compounds are not commercially available. Some of these compounds may be suitable for synthesis under the next phase of this effort. During the selection process the vast majority of the mixtures was eliminated from further consideration because of insufficient thermal stability or lack of commercial availability. The two families of mixtures selected for further experimental evaluation have hydrogen yields from 7.3% to 8.5%, depending on the formulation. Higher yields, as high as 12%, may be achievable if compounds such as Nr.7 listed in Table 1 can be used as additives. During the course of reactant preparation and testing, ARC acquired the capability to manufacture and press hydrogen gas-generating formulations. A tentative formulation for Phase II has been selected.

(2) Hydrogen gas-generating reactant cartridge

The hydrogen-generating mixtures are pressed into pellets or small cylinders, which will be stacked and loaded into a thin-walled aluminum cartridge (coke-can type). The hermetically sealed cartridge contains at its bottom a percussion primer and at its top a felt-metal screen system. The reactant cartridge is designed to fit into the reaction chamber and thus provides recharging capability.

(3) Hydrogen gas-generator reaction chamber

The reaction chamber accommodates the reactant cartridge. The chamber is closed with an end cap, which is equipped with a striker for actuating the percussion primer. The percussion primer ignites a disc of "Heat Paper" or similar material, which in turn provides the heat for starting the reaction of the hydrogen-generating mixture. The mixture reacts at a rate that depends on the composition and density of the mixture, and hydrogen is liberated during the reaction. The residue from the reaction forms a solid clinker. A minimum burning rate is required to maintain a self-sustaining reaction. Because the hydrogen consumption by the fuel cell lags behind the production rate determined by the burning rate, a holding tank for the evolved hydrogen is required.

(4) Weight and dimension of the holding tank

The holding tank is subjected to the same pressure as the reaction chamber. The higher the operating pressure, the smaller the volume of the holding tank can be kept for the same amount of hydrogen gas. Because of safety considerations, the pressure should not exceed some two or three thousand psi. The volume of the holding tank is directly proportional to the size of the reactant cartridge (all other parameters kept constant). In other words, the weight and the dimensions of the holding tank and of the reaction chamber can be reduced if the reaction chamber is frequently reloaded with small reactant cartridges. For a 150-Watt system, hourly reloading would be required when a 100-g reactant cartridge is used, whereas with a 400g cartridge, the reactant cartridge would have to be replaced every four hours. However, when the 100g cartridge is used, then the cartridge volume, the reaction chamber volume, and the holding tank volume would only be roughly $\frac{1}{4}$ of those required when the 400g cartridge is used, and corresponding substantial weight reductions of the total hydrogen gas-generator system could be achieved.

The size of the holding tank could be further reduced. This could be accomplished, for example, with a large number of disc-like pellets stacked in the reaction chamber. The pellets would have to be separated by a thermal barrier, and each pellet would require an individual ignition system being controlled by a timing device. But such a reactant cartridge would be extremely complex and costly, and the weight savings, particularly for longer mission times, would be marginal. Alternatively, a simple mechanical reloading device for individual small cartridges could be adopted that would provide some weight savings because the holding tank could be considerably smaller.

(5) Conclusion

The original goal of designing a hydrogen gas-generating system with a 10% yield per system weight has not been achieved. However, a hydrogen gas-generating system has been designed based on short reloading cycles, which consist of a reactant cartridge suitable for reloading, a reaction chamber, and a holding tank. This system offers substantial weight savings over conventional batteries for longer mission times, e.g., for missions extending over several days or even weeks.

IV. Hydrogen Storage and Generation Methods

1. Pressurized hydrogen stored in gas cylinders or adsorbed/desorbed from suitable materials

Internal gas pressure in gas cylinders used in the military was generally limited to 2,000psi. It was stated that for the present application a pressure of 7,000psi might be acceptable.

The Soldier Cooling Power Module, developed for the Army, contains a 770g hydrogen tank that holds up to 46g (23 moles) hydrogen at 7,000psi. Assuming, for simplicity, a spherical shape of the hydrogen tank, the weight of a similar tank holding 120g hydrogen at 7,000psi would be approximately 1300g (2.7L). Should, however, the maximum pressure in the tank be reduced (for safety considerations), both the total weight and the volume of the tank would increase correspondingly.

Novel hydrogen storage techniques are being researched, e.g., ab- or adsorption by carbon-based materials in the nanometer-size regime ("carbon nanotubes"); however, no immediate practical applications are envisioned (1). Another current research topic is to identify a metal hydride capable of 5 weight-percent hydrogen storage capacity with a dehydrogenation temperature of $<150^{\circ}\text{C}$ (2). A team at Sandia National Laboratories in Livermore, CA, is investigating the potential of materials like LaNi and FeTi for hydrogen storage (3). These materials operate at or near room temperature and have relatively low heats of formation, but their hydrogen weight density is low (about 2%). Lightweight hydride materials such as Mg_2Ni have higher hydrogen weight densities, but they require elevated operating temperatures and have large heats of reaction (3).

At the recently conducted "Workshop on Hydrogen Storage and Generation Technologies for Medium-Power and -Energy Applications" in Orlando, FL (April 8-10, 1997), a number of interesting hydrogen-generation approaches were presented, which are mostly still at the research stage, among others the hydrolysis of organosilanes and organoboranes (Subash Narang, SRI International); dehydrogenation/hydrogenation of a decalin/naphthalin system (Raouf Loutfy, Materials and Electrochemical Research Corp.) and other cycloalkanes (Craig Jensen, University of Hawaii); decomposition of ammonia (David P. Bloomfield, Analytic Power); adsorption/desorption of hydrogen on Fullerenes (John Van Zee, University of South Carolina); absorption/desorption of hydrogen using magnesium-based alloys (Roger Pyon, PRC); hydrogen encapsulated in micro-glass-beads (a fully developed approach; Michael Monsler, W.J. Schafer Associates, Inc.); and hydrogen absorption/desorption by graphite nanofibers (which supposedly absorb approximately 30% H_2 by weight; Nelly Rodriguez, Northeastern University).

To sum it up: The above techniques meet many of the requirements listed, but, with the exception of the system developed by W.J. Schafer Associates, they are still at the research stage, and, for most systems, the capacity (g H_2 / g system) and volume requirements (g H_2 / cm^3 system) are far from being met. Also, some of the systems would

require an external power supply. However, as research in this area is continuing, such systems might become attractive for hydrogen storage at some time in the future.

2. Wet hydrogen-generating systems

In "wet" systems, reactive metals (Li, Na, K, Mg) or metal hydrides (LiH, MgH₂, NaBH₄, LiAlH₄, NaAlH₄) are reacted with liquid protonic systems (water, acids, alcohols, etc.). These reactions are usually highly exothermic, and a large excess (up to 20-fold) of the liquid component (or another coolant) is required to prevent excessive evaporation of the liquid, which would result in diluting the evolving hydrogen gas. Such systems are quite complex. However, Roger Pyon from PRC described a wet system that is already fully developed and tested, which delivers about 9 g H₂ (system weight: 1 kg, or 0.9% yield) and is relatively inexpensive. In general, wet systems have a seemingly very attractive yield of 4-10% hydrogen, based on the reactants weight alone, but this does not include the coolant weight. When the coolant weight is included, then the yields drop to less than 1%. Obviously, a system based on water will also be of only limited use under arctic conditions. "Pseudo-wet" systems, combinations of metal hydrides and hydrates (e.g., LiOH·H₂O, (HOOC)₂·2H₂O, KAl(SO₄)₂·xH₂O, etc.) also generate hydrogen, but both the yields and the thermal stability are low.

In summary, while "wet" hydrogen-generating systems are very attractive for small-scale generation of hydrogen in laboratories, they are usually too complex for field applications, and the capacity, volume, and stability requirements for this application are not met.

3. Solid-state hydrogen gas-generating systems

Solid-state hydrogen gas-generating systems can either be based on decomposition reactions of suitable hydrogen-rich compounds, on reactions between hydrogen-rich components, with hydrogen as one of the reaction products, or on combinations of the two. All of these approaches have been investigated by a variety of research teams, with varying degrees of success.

It should be kept in mind that all of the solid-state reactions discussed below will leave a (solid) residue that represents "dead weight", and its total weight should therefore be kept to a minimum. Consequently, the non-hydrogen chemical elements in these formulations should be, to the extent possible, light-weight, and therefore preferably be selected from the first period of the Periodic System.

A. Hydrogen generation based on the decomposition of hydrogen-rich compounds

For large-scale hydrogen generation, multiple avenues have been explored, e.g., use of nuclear and solar energy for electrolysis of water, biomass conversion, petrochemicals, etc. (4), but these approaches have no bearing on our specific application and will therefore not be discussed.

Based on what was said above, compounds that contain, in addition to hydrogen, only

boron and nitrogen in the same molecule and that release their hydrogen upon activation (heating) appear almost ideal for the envisioned application, as, for example,

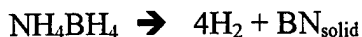

The hydrogen yield of 24.4% from this reaction, upon complete decomposition, looks extremely attractive. Unfortunately, this compound, ammonium borohydride, starts to decompose above -40°C (5).

Below are discussed other similar hydrides and formulations containing them that have been investigated and that, based on the theoretical hydrogen yields, looked attractive for this application.

Ammonium octahydrotriborate, $\text{NH}_4\text{B}_3\text{H}_8$

The theoretical hydrogen yield, upon complete decomposition, is 20.7%. Unfortunately, this compound is unstable at ambient temperature, and even when highly purified, decomposes at 60°C (6).

Ammonia borane, NH_3BH_3

This is probably the most extensively researched compound in this category, with a theoretical hydrogen yield of 19.4%, and it is therefore discussed here in greater detail. The following summary (although probably not complete) provides an historical account of the more important research efforts devoted to this compound. Rockwell International (6) synthesized this compound and, in a January 1978 report, reported a thermal stability of up to 80°C when highly purified, and a melting point of 104.5°C (dec.). A research team from Hercules Inc., funded by the U.S. Army Missile Command, presented data on hydrogen/deuterium systems based on "... NH_3BH_3 formulated with suitable co-reactants in a manner that eliminates the generation of other gases" (7). A number of formulations was tested, but the final conclusion was: "Thermal stability tests at 60°C indicate that ammonia borane formulations are not stable at elevated temperatures". Nevertheless, funding for the evaluation of this compound continued. Artz and Grant from Rockwell International reported in 1980 that thermal decomposition of NH_3BH_3 occurs in four steps, the last one (from $(\text{BNH})_x$ to $x\text{BN} + x/2 \text{H}_2$) at 900°C (8). A heat source was needed to achieve this decomposition. The hydrogen purity was 94-98%, but adequate filtration of the gas stream could not be accomplished. Chew and coworkers reported that Fe_2O_3 and CuO seemed to catalyze the decomposition (5). In June 1981, Artz and Grant reported that a temperature equal to, or higher than, 1038°K (765°C) is needed to complete the decomposition reaction. They also mentioned solids removal from the gas stream as a major problem. The hydrogen gas collected from large-scale (100 - 500g) testing contained 0.2 to 1.1% ammonia and 0.1 to 1.6% carbon monoxide (from the Kraton binder used in the formulation). In September 1983, Artz and Grant reported: "...long-term stability testing of the H_2 -generating formulations containing ammonia borane ... has revealed significant decomposition at temperatures as low as 50°C ... that (ammonia borane) did not have sufficient thermal stability to be incorporated in a fieldable system" (9). Finally, Browne and Kydd (10) evaluated NH_3BH_3 as main component in various

hydrogen-generating formulations. They used ammonia borane "... because it is stable and readily available", but later cautioned on the "... instability of the final product". However, no data on short- or long-term stability were reported.

Diborane diammoniate, $\text{BH}_2(\text{NH}_3)_2\text{BH}_4$ (DDA)

The theoretical yield is 19.6% H_2 . This compound was also investigated by the Rockwell International team (6). They found that it is stable up to 95°C , and that mixtures of DDA and hydrazine bisborane gave good hydrogen yields, but only at high temperatures (1115°C) could complete decomposition of DDA be attained. Satisfactory filtration of the gas stream could not be achieved, and the burning rate was much too fast. Artz and Grant (8) reported later that DDA is "... chemically incompatible with all the primary heat source formulations tried", and then stated that DDA is not acceptable (11). Chew *et al.* (5) stated that according to their investigations, DDA is too sensitive to decomposition to be of practical value.

Ammonia triborane, $\text{NH}_3\text{B}_3\text{H}_7$

The theoretical yield of 17.8% makes this compound look very attractive (10); however, the compound decomposes at its melting point of 74°C (6,10), and it is not deemed acceptable in hydrogen-generating mixtures (11).

Hydrazine bisborane, $\text{N}_2\text{H}_4 \cdot 2\text{BH}_3$

The theoretical yield, when completely reacted, is 16.9% hydrogen. This compound is reasonably stable to 160°C , although slow hydrogen evolution starts at about 100°C (6). However, when it was combined with ammonia borane and tested, the mixture burned much too fast (6) and tended to detonate when the hydrazine bisborane percentage in the formulation approached 30% (12,13), and no solution for the efficient filtration of the gas stream could be found (6). Results from electrostatic tests in air and in nitrogen indicate that hydrazine bisborane may not be acceptable for military applications (11).

Magnesium borohydride diammoniate, $\text{Mg}(\text{BH}_4)_2 \cdot 2\text{NH}_3$

This compound is supposed to be stable up to 100°C (6). The preparation of a mixture of this compound with lithium nitrate and Teflon powder as heat source was reported (14). The mixture looks attractive (theor. yield 13.6% hydrogen, stable for 35 days at 75°C), but the evolved gas most likely contains sizeable amounts of CO , N_2 , and possibly NH_3 . Also, the burning rate (1-2 in/sec) and reaction temperature (894 - 1075°C) are rather high.

Other potentially useful compounds with a high hydrogen content have been reported in the literature, but not enough data are available for an evaluation of their applicability to this project. In addition, these compounds are not commercially available, and custom synthesis cost would probably be in the range of \$500-800 for a 10-g sample. Examples of such compounds are $\text{N}_2\text{H}_4 \cdot \text{BH}_3$, $\text{Mg}(\text{NH}_3)_6(\text{B}_3\text{H}_8)_2$, $\text{BH}_3(\text{NH}_3)_2\text{B}_3\text{H}_6$, Li_3AlH_6 , HMgBH_4 , HMgAlH_4 , and $\text{BH}_4\text{MgAlH}_4$.

The compounds discussed above are not commercially available, except for ammonia borane (approx. \$70/10 g). The most attractive compound seems to be magnesium

borohydride diammoniate, which, if it becomes available at a reasonable price, might be added to formulations proposed later in this report.

For illustration, some hydrogen-generating compounds and formulations discussed above are listed in Table I, together with their theoretical hydrogen yields and other pertinent information. Also included are some formulations that are discussed below.

B. Hydrogen generation based on reactions between hydrogen-rich compounds

The instability of ammonium borohydride, NH_4BH_4 , at temperatures higher than -40°C prompted in 1968 a research team at the Naval Ordnance Station in Indian Head, Maryland, to attempt to generate NH_4BH_4 *in situ*, followed by the immediate decomposition of this intermediate to $\text{BN} + 4\text{H}_2$. The compositions investigated generally consisted of mixtures of dry ammonium salts and complex hydrides, with the general reaction proceeding as follows:

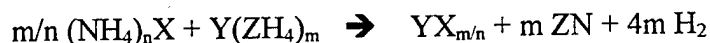

where:

X = acid radical, such as halogen, SO_4 , etc.

n = valency of the acid radical

Y = metal capable of being a ligand in complex hydrides,
such as Li, Na, K, Mg, etc.

m = valency of metal Y

Z = trivalent metal forming complex hydrides, such as B or Al.

Such and similar reactions were extensively explored and the results documented in patents and reports (15-25).

The reaction of ammonium fluoride with lithium borohydride appears especially attractive because of its high (theoretical) hydrogen yield (13.6%; see Table I) and its low heat of reaction (-48 kcal/mol, using data from Table 2). However, the mixture begins to react at temperatures as low as 50°C . The stoichiometric mixture of ammonium fluoride with sodium borohydride also shows decomposition in the same temperature range. Mixtures of ammonium chloride with sodium aluminum hydride or lithium aluminum hydride exhibit considerably greater thermal stability. For stoichiometric ammonium chloride/metal hydride mixtures, the calculated gas temperature may be as high as 1400°K (1130°C). Lower gas temperatures can be achieved by using excess amounts of LiAlH_4 , which decomposes endothermically above 120°C under hydrogen evolution.

Such mixtures, which also included a binder and a burning-rate modifier, were successfully developed and tested as hydrogen sources for a variety of military applications. The mixtures satisfied all military specifications. One particular system was developed and successfully tested for in-flight inflation of a search-and-rescue balloon: it produced approximately 120L hydrogen in 12 sec at temperatures below 150°C . Another system,

thermally stable up to 172⁰C, was developed as power supply for fluidic sequencers. During this research, burning-rate modifiers were identified that either accelerated or decelerated such reactions.

Reactions of metals and simple metal hydrides with ammonium or hydrazinium salts have also been investigated and patented by the Indian Head team. Examples are Mg, Al, LiH, MgH₂, CaH₂ + NH₄X or N₂H₆X₂. These materials are commercially available at acceptable purity and reasonable cost. Most of the combinations are stable to approximately 150⁰C. The reaction temperatures are usually high, but some combinations, e.g., CaH₂ + NH₄Cl, require an external heat source for a sustained reaction. Combinations of different components may lead to balanced formulations that may provide on/off capability, requiring only a small heat source for initiation. However, the hydrogen yields of these mixtures are considerably lower than those from the ammonium chloride/complex hydride systems.

A research team based at Edwards Air Force Base, California, carried out a project to design a solid-fuels system for a chemical laser, based on a deuterium/fluorine reaction. The deuterium-generating system was the same system that had earlier been developed by the Indian Head team, except that deuterated components were used. Extensive testing and scale-up evaluations were performed by the Edwards AFB team. The results of these evaluations confirmed that some of the formulations previously designed and tested (including binder, burning rate modifier, etc.) (15-25) generated high yields of hydrogen or deuterium at high purity (26).

V. Technical Approach

This effort was focused on ammonium salt/complex hydride systems, because they seemed to be most likely to meet the requirements specified earlier. These binary mixtures (not counting binder and catalyst) do not need auxiliary feed/control systems, and they function under a wide range of temperature conditions.

Selection of reactant mixture

From the results of already conducted experiments and tests, including our own earlier results (15-25) and the test results generated during the four-year Air Force evaluation (26), we extracted all valid information that was applicable to our basic formulation program to optimize compositions for our particular application. The experiments, which we carried out under this program, were directed toward thermal stability, ignitability, safety, and gas composition. Some data needed to be reestablished for the ingredients purchased for this program.

For the selection of the most promising mixture(s), the following criteria were applied in order of significance:

- (1) thermal stability
- (2) ignitability

- (3) temperature of the reaction
- (4) hydrogen yield
- (5) physical properties of the solid residue
- (6) commercial availability of the components.

Specific requirements

Since the intended use of the HGGS that is presently developed under this program is different from the uses for which earlier systems have been developed (15-26), the importance of various parameters is sometimes quite different. For example, when the generated hydrogen was used for in-flight inflation of a balloon (generation of 120L hydrogen in 12 sec was required), then gas impurities and minor amounts of small particulates in the gas could be tolerated, but burning rate and gas temperature (which had to be low enough so as not to melt the balloon material) were very important. For some other applications, very high burning rates (up to several inches per sec) and high gas temperatures (up to $1900^{\circ}\text{K}/1627^{\circ}\text{C}$) were crucial requirements.

The requirements for the present application specify the absence of impurities like NH_3 , CO, sulfur compounds, and particulates in the gas stream (as well as high temperatures of the hydrogen gas entering the cells), because they would impede the proper functioning of the PEM fuel cells (although research is ongoing to raise the CO tolerance of PEM cells - see ref. 27).

However, one must realize the limits in tailoring formulations to fulfill certain requirements. For example, it is not possible to develop a formulation that is stable up to 130°C , is safe (but easily ignited), and, once the reaction has been started, will proceed to generate hydrogen at only 80°C . It is obvious that the gas temperature can not be less than the reaction temperature, which, in order for self-propagation of the reaction to take place, will in our example be considerably higher than the "safe" temperature of 130°C . For a self-propagating reaction to proceed, a minimum reaction temperature and rate are dictated by the composition and environment of the specific system. In our particular case, the temperature of the evolved hydrogen will therefore be higher than desired; therefore, a holding tank is required for storage and temperature adjustment for the hydrogen that is released from the reaction of incremental charges. In this case, some cooling is provided by the hardware, which acts as a heat sink, and by funneling the gas into the holding tank where the gas can cool down further.

Based on our literature search and evaluation (1-14) and on information otherwise already available to us (15-26), we focused our efforts, as stated above, on the reaction between ammonium halides and complex metal hydrides. The following compounds were selected for investigation:

- (1) ammonium fluoride, NH_4F
- (2) ammonium chloride, NH_4Cl
- (3) hydrazine dihydrochloride, $\text{N}_2\text{H}_6\text{Cl}_2$
- (4) lithium hydride, LiH
- (5) lithium borohydride, LiBH_4

- (6) sodium borohydride, NaBH_4
- (7) lithium aluminum hydride, LiAlH_4
- (8) sodium aluminum hydride, NaAlH_4
- (9) ammonia borane, BH_3NH_3 .

The last compound was added because of its reportedly good thermal properties, as known at that time. The compounds received from the supplier had to be evaluated as to particle sizes, and, when necessary, were ground to smaller sizes, either by hand or in a hammer mill, and sieved. In addition, compounds 1-3 had to be dried in desiccators over phosphorus pentoxide. All operations that involve any of the hydrides must be conducted in a moisture- and oxygen-free atmosphere. Thus, all such operations were conducted in a (commercially available) glove box, which was modified for this particular work. The glove box was continuously flushed with dry nitrogen to remove all traces of water vapor and oxygen that may have been introduced into the box when additional materials or equipment were entered. Working with a glove box is very cumbersome, and special training, experience, and patience are needed to put the glove box to efficient use.

Thermal stability

To determine the thermal stability of the promising compounds and formulations, the values published in the literature were reviewed, and additional tests were performed, as needed. Digital scanning calorimetry (DSC) testing was conducted for compounds (1) and (4)-(9) [compounds (2) and (3) had been tested earlier]. All DSCs were performed at a heating rate of $10^\circ\text{C}/\text{min}$, which is quite rapid; and the sample sizes for DSC determinations were only 1-2 mg, therefore, these results can only be used for screening purposes.

LiH , LiAlH_4 , and NaAlH_4 (except for a small endotherm) seem to be stable to at least 100°C ; BH_3NH_3 starts decomposing around 100°C ; NaBH_4 does not show a distinct exotherm but seems to slowly decompose with increasing temperature; NH_4F shows strong endotherms that start below 60°C ; and LiBH_4 starts decomposing at about 50°C . For illustration, copies of the DSC diagrams for LiBH_4 , LiAlH_4 , and NaAlH_4 are included as Figures 1, 2, and 3.

Thermochemical calculations

Thermochemical calculations were performed with various combinations of the above compounds (BH_3NH_3 was not included at this time because of additional data discovered in the literature that characterized the use of BH_3NH_3 in formulations as risky and questionable). The values used in our calculations (and accumulated from a number of sources) are presented in Table II, and calculated results for the mixtures under consideration are presented in Table III (the effects of binder and/or catalyst were not considered in these calculations). It should be noted that some thermochemical and other compound-specific constants published in handbooks, textbooks, and scientific publications can significantly differ for the same compounds, sometimes up to a factor of

two. Since we did not have the time, experience, equipment, and inclination to verify such values, we decided to use for our calculations the values listed in Table II. Computer computations were performed with NEWPEP to evaluate the theoretical composition of the gaseous reaction products. The theoretical predictions suggest that the concentrations of NH_3 and CO are less than 10^{-15} mols per 100g reactant after expansion (see Table IV).

DSC testing of promising mixtures

Small amounts of the following two-component stoichiometric mixtures were prepared in the glove box, and portions of these mixtures were subjected to DSC:

- | | | |
|---|--|--|
| 1. $\text{NH}_4\text{F} + \text{LiBH}_4$ | 6. $\text{NH}_4\text{Cl} + \text{LiBH}_4$ | 11. $\text{N}_2\text{H}_6\text{Cl}_2 + 2 \text{LiBH}_4$ |
| 2. $\text{NH}_4\text{F} + \text{NaBH}_4$ | 7. $\text{NH}_4\text{Cl} + \text{NaBH}_4$ | 12. $\text{N}_2\text{H}_6\text{Cl}_2 + 2 \text{NaBH}_4$ |
| 3. $\text{NH}_4\text{F} + \text{LiAlH}_4$ | 8. $\text{NH}_4\text{Cl} + \text{LiAlH}_4$ | 13. $\text{N}_2\text{H}_6\text{Cl}_2 + 2 \text{LiAlH}_4$ |
| 4. $\text{NH}_4\text{F} + \text{NaAlH}_4$ | 9. $\text{NH}_4\text{Cl} + \text{NaAlH}_4$ | 14. $\text{N}_2\text{H}_6\text{Cl}_2 + 2 \text{NaAlH}_4$ |
| 5. $\text{NH}_4\text{F} + 4 \text{LiH}$ | 10. $\text{NH}_4\text{Cl} + 4 \text{LiH}$ | 15. $\text{N}_2\text{H}_6\text{Cl}_2 + 8 \text{LiH}$ |

The DSC diagrams for mixtures 1, 2, 3, 6, and 13 exhibited exotherms starting below 90°C , which is definitely too low (considering the large uncertainties associated with DSC determinations of milligram samples); mixtures 4 and 12 could be of marginal use, with exotherms starting around 100°C ; mixtures 5, 7, and 11 did not fully react, or did not react at all; mixtures 8 and 9 looked best, with exotherms starting at 150°C and 179°C , respectively; mixture 14 looks interesting, with a small exotherm at 127°C and a strong one at 180°C - it may be possible to anneal such a mixture at, for example, 140°C , to get rid of the early small exotherm (which could have resulted from a minor impurity); the same could possibly be true for mixture 12. However, this is beyond the scope of Phase 1 of this project. Mixture 10 shows a strong endotherm starting at 90°C , followed by a strong exotherm starting at 230°C . It is not clear, what this means, and more work would have to be done to characterize this mixture. Finally, mixture 15 exhibits a small exotherm at about $40\text{-}50^\circ\text{C}$, followed by a strong one starting at about 100°C . Again, the diagram does not provide a clear-cut answer to the stability of this formulation. For illustration, the DSC diagram for mixture 8 is included as Figure 4.

The most promising mixtures, #8 and #9, are combinations of ammonium chloride with lithium aluminum hydride and sodium aluminum hydride. This is in line with earlier results. Since we know from earlier experiments that mixtures based on sodium aluminum hydride exhibit much higher reaction temperatures and burning rates than those based on lithium aluminum hydride, we concentrated our efforts on formulations based on the latter. To get a better handle on the stability of mixture 8 (the "prototype" formulation), the DSC for mixture 8 was repeated at a rate of $1^\circ\text{C}/\text{min}$. As can be seen from Figure 5, the exotherm starts at about 150°C , which indicates that this combination satisfies our stability requirement. Therefore, formulations consisting of combinations of ammonium chloride, lithium aluminum hydride, binder (Kraton in toluene), and a catalyst (iron oxide, Fe_2O_3) were further evaluated. Some of these mixtures have been prepared earlier on a small scale, others up to pilot-plant and even production scale, and a number of stability and

safety tests have been performed. Some general findings that apply to essentially all of these formulations are presented below.

Chemistry

The chemistry of these reactions has not been fully explored, but we envision the following reactions to be taking place, depending of the formulations:

Primary reaction:



Secondary reaction:

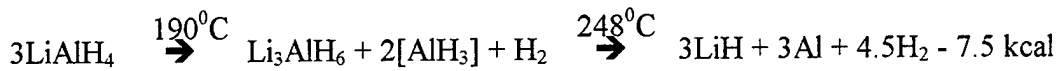

Side reactions:

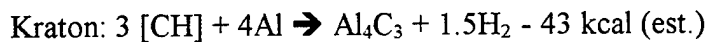
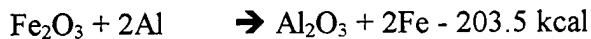

Hydrogen yields

There seems to be a general rule that the hydrogen yield of a given compound or formulation is inversely related to its thermal stability. This is illustrated in Figure 6, where the hydrogen yields of some "exotic" compounds and of some more conservative formulations are plotted against their decomposition temperatures. As can be extrapolated from this graph, the goal of producing 10% hydrogen, based on the total weight of the HGGs (including the weights of the grain, hardware, ballast tank, valves, etc.) can not be attained using the formulations evaluated under this project. Formulations that fulfill the requirements of thermal stability, gas purity, gas and residue temperature, and absence of particulates in the hydrogen gas, can only produce 7-10% hydrogen, based on the weight of the solid grain formulation. However, when the concept of using replaceable hydrogen-generating cartridges is applied, which is explained in more detail in another section of this report, hydrogen yields of 7-10%, based on the grain weight, may become attractive because the relatively high weight penalty mandated by the required hardware will become less important. Also, as will be briefly discussed later, the development of grains yielding up to 12% hydrogen seems to be possible.

Binder usage

It has been found very early that the addition of a binder to the formulation is needed to produce a cohesive grain that can easily be handled. Obviously, such a binder should not contain any reactive groups and no components that could generate unacceptable reaction products, such as H_2S or SO_2 . For all formulations, a styrene-isoprene copolymer was therefore used, which is manufactured under the tradename "Kraton" by the Shell Oil Company. Generally, 3-5% by weight of the binder, dissolved in toluene, is used in the formulations. To avoid the potential formation of undesirable hydrocarbons and CO during the reaction, the use of some inert inorganic material, which shows plastic properties at the pressure applied during grain extrusion, should be considered in future formulation improvements.

Burning rate modifiers (catalysts)

It has been experimentally determined that certain additives influence the burning rates of the mixtures. The modifier commonly used is Fe_2O_3 (iron oxide), which is effective in accelerating the reaction and is also inexpensive. Nickel acetyl acetonate has also been used in some formulations; it is about twice as effective as iron oxide. However, because of the potential formation of undesirable organic impurities resulting from the organic part of this compound, the use of nickel acetyl acetonate was not further pursued. The amount of Fe_2O_3 added to formulations varied from 0% to more than 10% by weight. For our purpose, a slow reaction is desirable, and therefore the amount of Fe_2O_3 should be kept to a minimum. However, for some formulations (especially those with a large excess of $LiAlH_4$) the addition of Fe_2O_3 is required for the reaction to go to completion.

Burning rates

The ammonium halide/aluminum hydride systems typically have burning rates of 0.1 to 1.5 cm/sec. The burning rates of the grains are obviously a function of the composition (including catalyst, as discussed above), the particle sizes of the ingredients (the smaller the particle size, the faster the burning rate - however, when very small particle sizes are used, e.g., $< 43 \mu m$, then the mixtures are more susceptible to ignition by friction during processing!), and the grain density (the higher the grain density, the faster the burning rate). But, unlike most rocket propellant burning rates, the HGG reactant burning rates are largely unaffected by the chamber pressure; they decrease with increasing chamber pressure and then reach a plateau. This has been tested with selected mixtures to up to 8000 psi chamber pressure. As discussed earlier, burning rates can also be influenced by additives that decompose under H_2 evolution, e.g., $LiAlH_4$. There is some effect of the initial temperature of the HGGs and the grain on the burning rate; for one particular formulation of NH_4Cl and (excess) $LiAlH_4$, the burning rate increased by approximately 35% when the initial temperature of the grain was increased from $-54^\circ C$ to $+93^\circ C$.

Grain design

As with propellants, the design of the grain (single- or multi-grain end burner, star configuration, pellet box, etc.) decidedly influences the burning rate. The optimum grain design is dictated by the required mass flow rate and the volume constraints. In general, an end-burner design is preferred, whenever feasible, because of its simplicity. End-burner designs (with inhibited grain sides) exhibit the slowest burning or gas-evolution rates, which is, for this particular application, most desirable.

Clinker formation

The combustion residues of formulations we are considering, especially formulations that contain an excess of LiAlH_4 , are initially mixtures of solid and liquid products, which form a cohesive "clinker" that completely retains the non-gaseous combustion products, but remains sufficiently porous to allow the passage of the evolved hydrogen through it. In fact, these clinkers are so highly cohesive that for effective filtration only filters with pore sizes of 10 to 50 μm were required, which were then only slightly clogged during test firings. This is in marked contrast to the residues resulting from the "exotic" compounds, where up to 60% of the residues were entrained in the hydrogen as very fine particles, a problem that has not been resolved. Table III lists the theoretical densities of mixtures, which form such clinkers, before and after reaction. These values demonstrate that the calculated clinker volume is in almost all cases just about 50% of the calculated volume of the original formulation. It is speculated that the reason for the cohesiveness of the clinkers is the presence of LiH , which, with its melting point of 680°C , is molten at the reaction temperature, and thus provides the "glue" for the clinker components.

Disposal of spent cartridges

As described below, the reactant grain will be encased in a reactant cartridge, with a gas-filtering unit located between the grain and the cartridge exit port. The residue from the reaction forms a clinker, which is nominally a fused mixture of LiCl (lithium chloride), AlN (aluminum nitride), LiH (lithium hydride), Al (metallic aluminum), and small amounts of Al_2O_3 (aluminum oxide), Al_4C_3 (aluminum carbide), and Fe (metallic iron). LiCl is a water-soluble salt similar to sodium chloride, and Al_2O_3 , in some of its modifications, is a normal soil constituent.

With moisture, the following (simplified) reactions occur:

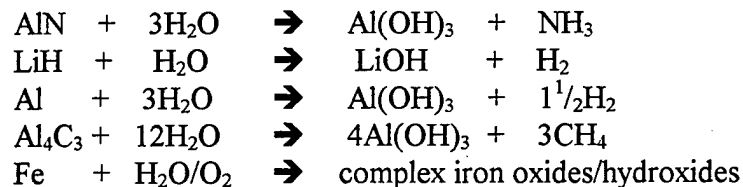

Al(OH)_3 (aluminum hydroxide) is a soil constituent; NH_3 (ammonia) is a water-soluble gas, toxic at higher concentrations - its aqueous solution is used on a large scale in

agriculture as liquid fertilizer; LiOH (lithium hydroxide) is a strong base, which, when exposed to the atmosphere, strongly absorbs carbon dioxide and is converted to Li₂CO₃ (lithium carbonate), an innocuous, only sparingly water-soluble compound (LiOH has been used as carbon dioxide absorbent in space vehicles). H₂ (hydrogen) is a non-toxic, flammable gas, but at the concentrations encountered during the disposal, it will not pose a safety hazard. CH₄ (methane), too, is a flammable gas, but the small amounts resulting from the disposal are no safety hazard (a ruminating cow produces much more methane than a spent cartridge).

In summary, disposal of spent cartridges should be no problem, if they either are left alone, exposed to the atmosphere, for a prolonged period of time, or if they are immersed in an excess of water in the open air, and the resulting basic solution is left to react with atmospheric carbon dioxide. In fact, lithium manufacturing companies may even be interested in recycling the residue from such disposal because of its high lithium content.

Safety test results

Mixtures of ammonium chloride with lithium aluminum hydride, catalyst, and binder have been subjected to standard safety and other tests. The results are listed below.

NH₄Cl + 2LiAlH₄

Formulation: 39% NH₄Cl, 51% LiAlH₄, 5% Fe₂O₃, 5% Kraton

DTA: 135C⁰

Sliding friction: 320 lbs

Impact: 100 mm/5kg

El.stat. discharge: 0.0125 joules

Gas analysis: 99.5 mole% H₂

Calculated gas temperature: 826⁰K = 553⁰C

Burning rate: 0.2 cm/sec between 400 and 8,000 psi

NH₄Cl + 3LiAlH₄

Formulation: 26.8% NH₄Cl, 56.8% LiAlH₄, 13.0% Fe₂O₃, 3.4% Kraton

This formulation has a very high Fe₂O₃ content in order to increase the burning rate.

DSC: 160⁰C

Stability in air: no ignition or decomposition after 48 hours at 75⁰C in air

Gas temperature: calculated 986⁰K = 713⁰C

measured 516-616⁰K = 243-343⁰C

Detonation tests: with explosive booster charges: no detonations

card gap tests ("zero cards"): no detonation

Impact: no detonation or reaction up to the 200-kg-cm limit of the impact tester

Ignition and unconfined burning tests: burned vigorously but smoothly

Interim hazards classification by the Air Force Systems Command, Aerospace Safety

Division:

Quantity distance class - 2
Storage compatibility group - A
DOT class - flammable solid
DOT markings - flammable solid N.O.S.

Formulation: 29.4% NH₄Cl, 62.6% LiAlH₄, 4% Fe₂O₃, 4% Kraton
ABL friction, 10 neg.: 200 psi @ 90°C
Impact, 10 neg.: 95 kg-cm
El.stat. discharge, 10 neg.: 0.38 joules.

VI. Recommended Formulation for Prototype Demonstration

Based on the information discussed above, we recommend the following formulation for use in the HGGs of Phase II of this project:

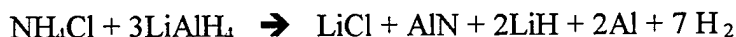

This formulation will be augmented with 4% Fe₂O₃ as catalyst and 4% Kraton as binder. The theoretical hydrogen yield for the basic reaction is 8.4%, or 0.94L/g; the presence of the catalyst and the binder will reduce this yield to 7.7%, or 0.86L/g.

This formulation is similar to the last two formulations discussed above. In one of these two formulations, the Fe₂O₃ content was 13%. The reason for using such a high Fe₂O₃ content in this formulation was to increase the burning rate of the mixture, because large amounts of hydrogen were required within seconds to feed a chemical laser system. In our case, the evolution of hydrogen should be slow in order to reduce the stress on the hardware and to give the hydrogen gas generated during the reaction more time to transfer part of its heat content to the hardware (which serves as a heat sink). Some iron oxide is required in the mixture, because its presence seems to be necessary to get the hydrogen evolution reaction to completion.

The formulation with 13% Fe₂O₃ meets military and DOT specifications as to thermal stability, impact, detonation, ignition, and unconfined burning requirements, and the mixture was classified as "flammable solid". The safety test results from our recommended formulation, with only 4% iron oxide, should be even better than those obtained for the 13%-formulation, because the reduced catalyst content should also reduce the sensitivity of the mixture.

According to the available data, the hydrogen generated from this mixture should neither contain ammonia nor carbon monoxide. Also, the solid residue (the "clinker") should prevent any significant amounts of small residue particulates from entering the gas stream.

The grains that are press-formed from this mixture are compact and can easily be handled. Once the grains have been shaped, they can be handled in air, for short durations, without negative impact.

The calculated hydrogen gas temperature for the mixture using 13% Fe_2O_3 is 713°C ; with the smaller amount of iron oxide in the mixture, the gas temperature should be closer to 670°C (because a significantly smaller amount of Fe_2O_3 can react with the formed Al in a thermite-type reaction with high heat output). Furthermore, the hardware associated with the HGGS will probably reduce the hydrogen temperature to 200 to 250°C , a temperature that will be further reduced when the gas passes through the filtering and valve system into the holding tank.

As outlined above, it may be possible to increase the hydrogen yield by 10 to 20% by modifying the composition of the mixture, without adversely affecting the temperature and safety profile.

With a small-scale mixture using the proposed formulation, several tests were performed. The DSC diagram of this mixture (Figure 7) shows an exotherm starting at 111.5°C , its thermal gravimetric analysis (Figure 8) shows the beginning of a reaction at about 115°C and a weight loss (approximately corresponding to the amount of hydrogen produced) of 8.293%, which is close to the calculated value of 7.8%, and a large-scale differential thermal analysis (DTA) test (using 1.8g of the mixture) shows an exotherm starting at about 125°C (Figure 9). A DTA test for the same formulation, but without Fe_2O_3 , is almost identical (Figure 10). The evolved gas, when analyzed with Draeger tubes, turned the color indicator in the tubes from yellow to blue, indicating the presence of a basic gas. However, no ammonia odor could be detected by the operator (the threshold for humans to smell ammonia is at about 5ppm), and subsequent GC analysis of the gas revealed that no ammonia was detectable in the gas. The likely explanation for the false positives indicating the presence of ammonia when Draeger tubes were used, is hydrolysis of very fine particles of the residue (AlN) with traces of moisture present in the tubes, generating ammonia. These particles were entrained in the gas because the burning was not confined (and the gas was not filtered); a fine dusty residue found in the Parr bomb after the reaction supports this scenario. In the envisioned application, any traces of solid AlN (or other solid residue) that might escape from the clinker-like reaction product would be trapped in the filtering system and could thus not enter the fuel cells and subsequently be hydrolyzed.

VII. Hydrogen Gas-Generator System

The hydrogen gas-generating system consists of three sub-systems:

- (1) a hydrogen gas-generator reactant cartridge,
- (2) a hydrogen gas-generator reaction chamber, and
- (3) a hydrogen gas holding tank.

A conceptual design of the hydrogen gas-generating system is depicted in Figure 11

(1) Hydrogen Gas-Generating Reactant Cartridge

The cartridge is made of thin-walled aluminum and is sealed like a coke can (see Figure 12). At the bottom of the can is a percussion primer the inside of which is in

contact with a layer of heat paper. The cylinder-like reactant pellets are stacked on top of the heat paper and covered by a disc of felt metal for particulate retention. After loading, the aluminum can is sealed in accordance with established industrial procedures.

(2) Hydrogen Gas-Generator Reaction Chamber

The hydrogen gas-generator reaction chamber (Figure 13) is opened for loading by removing the cap at the bottom of the chamber. The valve at the top of the chamber is closed to prevent air from entering the holding tank. After insertion of the reactant cartridge, which is opened like a coke can, the bottom cap is reattached to the reaction chamber, and the system is now ready for ignition of the reactant mixture. Prior to ignition, the on/off valve is opened so that the gases can expand into the holding tank. Ignition of the reactant mixture is achieved by pulling and releasing the striker. The reaction chamber is designed for 2000 psi operating pressure.

(3) Hydrogen Gas Holding Tank

The holding tank is designed, like the reaction chamber, for 2000 psi operating pressure. For first-time operation the holding tank must be free of air oxygen. This can be achieved by pre-filling the tank with hydrogen, evacuating it, or flushing it with nitrogen. The gas flow from the tank to the fuel cell is controlled by a pressure-reducing control valve (see Figure 11). When the pressure drops below a pre-set level, a new reactant cartridge is inserted to maintain a continuous flow of hydrogen gas to the fuel cell stack. A pressure indicator provides information when the system has to be reloaded.

(4) System Weight Considerations

The size of the reactant cartridge determines the weight of the gas-generating system. The smaller the weight of the reactant cartridge, the smaller can be the weight of the gas-generating system, but the time span between loadings is also shorter. The relation between gas-generating system weight and reactant cartridge weight is depicted in Figure 14 for reactant weights of 100 g, 200 g, and 400 g, respectively. Table V provides the data used for constructing the system-weight versus reactant-weight relationship. The data have been generated for aluminum 6061 with the "Under Pressure" computer program from Deep Sea Power and Light. For the holding tank, composites could be used. However, composites offer weight advantages only for larger tank sizes. In addition, because hydrogen can diffuse through composites, an aluminum container would be preferable. The trade-off between system weight and time between loadings depends on the specific application. With very small reactant cartridges, e.g., 10 g reactant weight, the holding tank could be very small, however, the time between loadings may then be of the order of minutes, which would require an automatic loading mechanism. Such a mechanism could be complex and might provide only minimal weight savings over a larger holding tank. Another alternative would be a reactant cartridge loaded with a large number of small, e.g., 10 g, disc-like pellets, separated by a thermal barrier. Each disc would have to be ignited separately. Such a system would also be complex and expensive. Thus, a simple holding tank appears to be the most viable alternative. The reactant cartridges can be produced at low cost, handled like a pyrotechnic material, and after use can readily be disposed of.

VIII. Areas of Future Developmental Work to Achieve Higher Yields

To further improve the hydrogen yield of the proposed and other similar formulations and their thermal stability, and to reduce the potential of introducing undesired impurities into the hydrogen gas stream, the following items seem to be worthy of further developmental work:

1. Replacement of the Kraton binder by an inorganic inert compound. This would eliminate the possible formation of CO during the reaction. A potential candidate could be potassium bromide, KBr, an inert salt that becomes plastic under pressure. It has been used for many decades as a matrix for organic compounds that were subjected to infrared analysis. The presence of this salt would also strengthen the "clinker" because of its relatively low melting point. Other inert inorganic compounds with similar properties should also be available.

2. One compound that definitely deserves a closer look (and that was discussed earlier) is magnesium borohydride diammoniate. Its addition to the recommended formulation should improve the hydrogen yield. The drawback of this compound, namely the formation and presence in the gas stream of a high percentage of very small particles, could most probably be overcome by entrapment of these particles in the clinker. A fairly simple (although not necessarily cheap) synthesis of $\text{Mg}(\text{BH}_4)_2 \cdot 2\text{NH}_3$ has been published. Other compounds that are unusually stable and deserve a closer look are complexes of AlH_6^{3-} , MgH_4^{2-} , MgH_3^- , and ZnH_4^{2-} ; prepared were HMgAlH_4 , HMgBH_4 , and $\text{BH}_4\text{MgAlH}_4$.

3. As briefly discussed earlier and as can be seen from the DSC data, some theoretically promising mixtures exhibit relatively small exo- or endotherms at fairly low temperatures, followed by larger exotherms at considerably higher temperatures. It is likely that these small exo- or endotherms result from impurities that, once reacted, pose no further problems. Annealing such mixtures at the temperature of the small exo- or endotherm may result in mixtures that are more stable than some of the mixtures presently under consideration.

IX. References

- 1 "Technical and economic analysis of renewables-based hydrogen production." M.K. Mann, P.L. Spath, and K. Kadam, National Renewable Energy Laboratory, Golden, CO. Paper presented at the 11th World Hydrogen Energy Conference, Stuttgart, Germany, 23-28 June 1996.
- 2 "The hydrogen research programme of the International Energy Agency (IEA)." G. Schriber, Swiss Federal Office of Energy, Berne, Switzerland. Paper presented at the 11th World Hydrogen Energy Conference, Stuttgart, Germany, 23-28 June 1996.
- 3 "Hydrogen storage and delivery system development for vehicular applications." J.L. Handrock and K. Wally, Sandia National Laboratories, Livermore, CA. Poster presented at the 11th World Hydrogen Energy Conference, Stuttgart, Germany, 23-28 June 1996.
- 4 Proceedings 11th World Hydrogen Energy Conference, Stuttgart, Germany, 23-28 June 1996.
- 5 "Solid fuel development." W.M. Chew, E.L. Andersen, and J.A. Neff, TRW Inc. Final Report, TR-RH-CR-80-13, U.S. Army Contract DAAK-79-C-0240. August 1980.
- 6 "Hydrogen-rich compounds." G.D. Artz and L.R. Grant, Rockwell International/ Rocketdyne Division, Canoga Park, CA, under Contract DAAK 40-77-C-0287-03 (U.S. Army Research and Development Command). January 1978.
- 7 "Solid fuels H₂/D₂ technology." D.T. Sauer, R.L. West, M.W. Orr, R.R. Russell, and A.H. Peterson, Hercules Incorporated, Bacchus Works, Magna, UT. Work sponsored by U.S. Army Missile R&D Command, Contract DAAH01-82-C-A234. June 1979.
- 8 "Ignition and combustion of B-N-H compounds." G.D. Artz and L.R. Grant, Rockwell International/ Rocketdyne Division, Canoga Park, CA. Work sponsored by U.S. Army Missile Command, DRCPM-HEL-7, Redstone Arsenal, AL. August 1980.
- 9 "Solid fuels (H₂/D₂) technology development." G.D. Artz and L.R. Grant, Rockwell International/Rocketdyne Division, Canoga Park, CA. Work performed under Contract DAAH01-82-C-A235 with the Directed Energy Directorate, Army Missile Laboratory, U.S. Army Missile Command, Redstone Arsenal, AL. September 1983.
- 10 "Hydrogen generating propellant." W.G. Browne and P.H. Kydd, Partnership Limited, Inc., Lawrenceville, NJ. Final Report, AFATL-TR-88-120, Air Force Armament Laboratory, Air Force Systems Command, U.S. Air Force, Eglin Air Force Base, FL. November 1988.

- 11 "H₂/D₂ Generator development." G.D. Artz and L.R. Grant, Rockwell International/Rocketdyne Division, Canoga Park, CA. TR-RH-CR-81-20, U.S. Army Missile Command, Contract DAAK40-79-C-0266. June 1981.
- 12 L.R. Grant and J.E. Flanagan, U.S. Patent 4,381,206 (1983).
- 13 G.D. Artz and L.R. Grant, U.S. Patent 4,468,263 (1984).
- 14 G.D. Artz and L.R. Grant, U.S. Patent 4,673,528 (1987).
- 15 W.F. Beckert, O.H. Dengel, and R.W. McKain, U.S. Patent 3,734,863 (1973).
- 16 W.F. Beckert, O.H. Dengel, and R.W. McKain, U.S. Patent 3,862,052 (1975).
- 17 W.H. Barber, W.F. Beckert, and O. H. Dengel, U.S. Patent 3,898,046 (1975).
- 18 W.F. Beckert, O.H. Dengel, and R.W. McKain, U.S. Patent 3,931,395 (1976).
- 19 W.F. Beckert, W.H. Barber, O.H. Dengel, and R.A. Robb, U.S. Patent 3,977,990 (1976).
- 20 W.F. Beckert, W.H. Barber, and O.H. Dengel, U.S. Patent 4,022,705 (1977).
- 21 W.F. Beckert, W.H. Barber, and O.H. Dengel, U.S. Patent 4,231,891 (1980).
- 22 W.F. Beckert, W.H. Barber, R.E. Bowen, and O.H. Dengel, U.S. Patent 4,341,651 (1982).
- 23 "Single integrated signal device." W.H. Barber, W.F. Beckert, and O.H. Dengel, Naval Ordnance Bulletin. December 1972.
- 24 "Hydrogen gas generators for actuator power sources." W.H. Barber and O.H. Dengel, NSWC/WOL TR 78-85. January 1978.
- 25 "Hydrogen gas generator as power supply for fluidic sequencer." W.H. Barber and O.H. Dengel, NSWC TR 80-169. August 1980.
- 26 "Chemical laser solid fuels program." J.E. O'Pray, R.E. Channell, and R.Q. Roberto, Air Force Propulsion Laboratory, Air Force Systems Command, Edwards Air Force Base. AFRPL-TB-76-82 (1976).
- 27 "An evaluation of the near-term competitiveness of H₂-based electricity generation systems in the changing U.S. utility industry." J.P. DiPietro and J.S. Badin, Energetics, Inc., Columbia, MD. Paper presented at the 11th World Hydrogen Energy Conference, Stuttgart, Germany, 23-28 June 1996.

Sample: H2GG #17 LIBH4
Size: 1.6400 mg
Method: DSC 10°C/MIN.
Comment: 10°C/MIN@50 ML/MIN N2, AL HERNOPH

DSC

File: D:\TA\DSC\DATA\H2GG#17.10D
Operator: ERIC GOFF
Run Date: 30-Dec-96 13:47

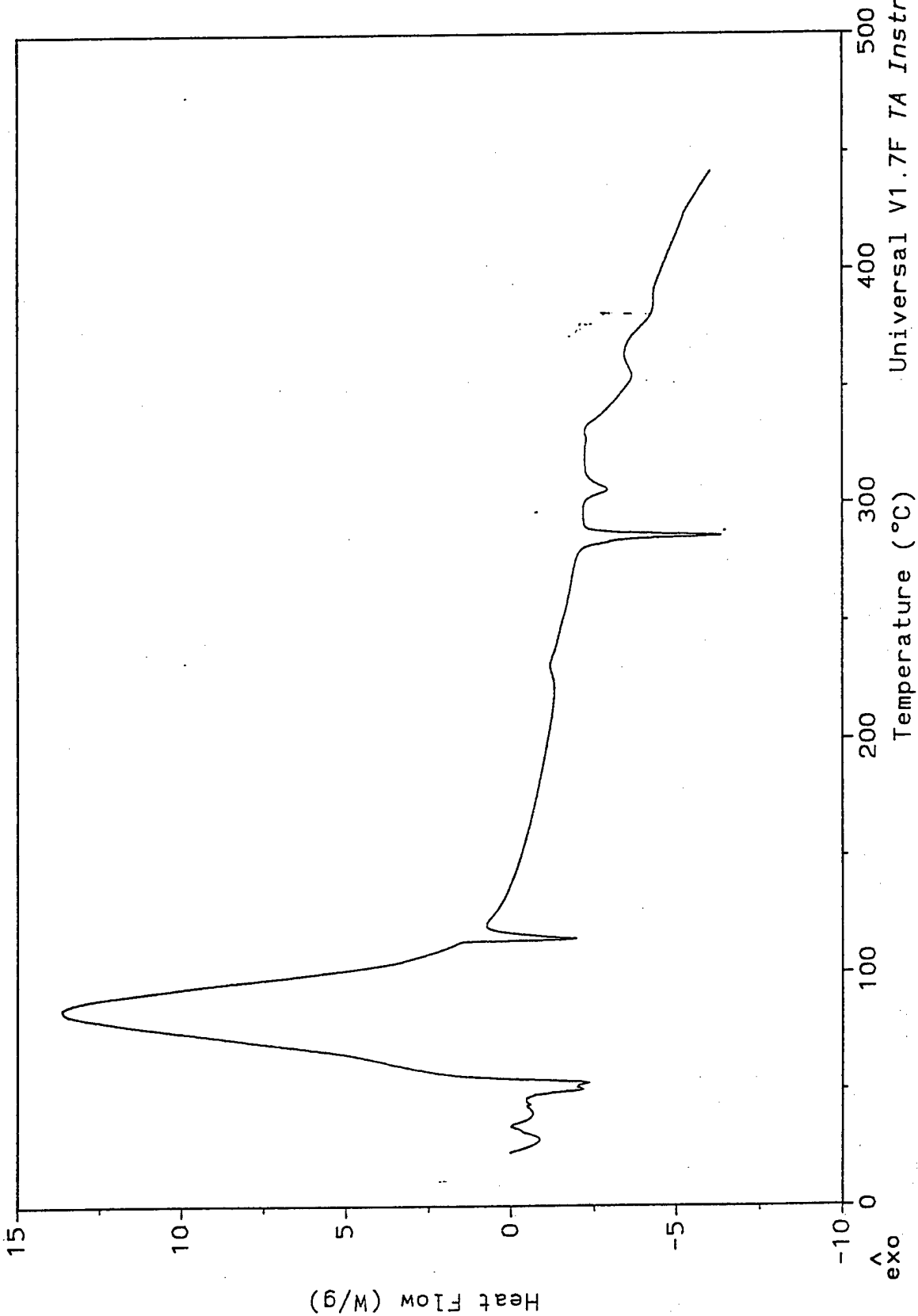

Figure 1

File: D:\TA\DSC\DATA\H2GG\IAH.19D
Operator: KEMPER EAGLE
Run Date: 2-Jan-97 17:30

DSC

Sample: H2GG #19 LIALH4
Size: 2.1200 mg
Method: DSC 10°C/MIN.
Comment: 10°C/MIN@50 ML/MIN N2, AL HERPH

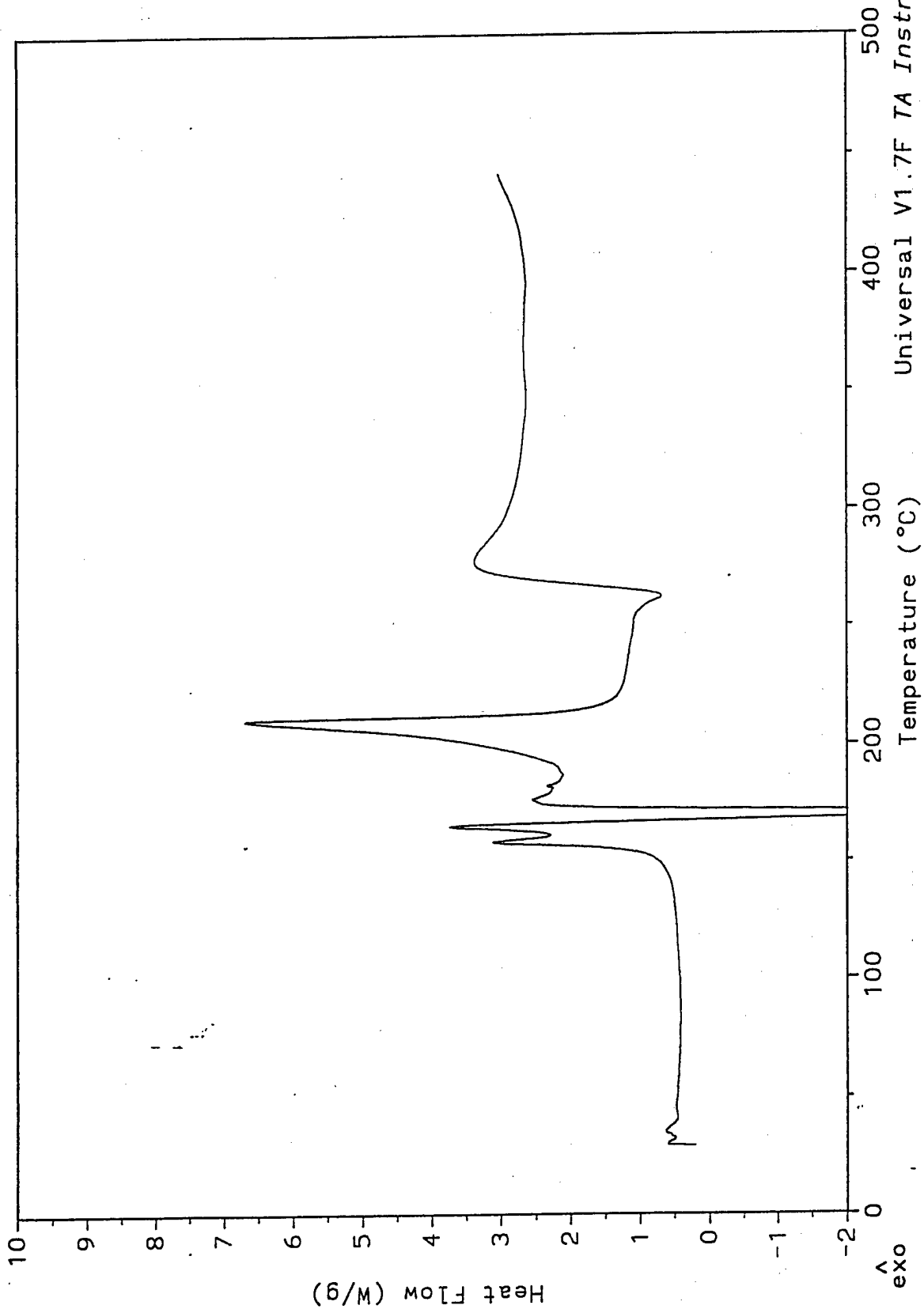

Figure 2

File: D:\TA\DSC\DATA\H2GGNAH4.20D
Operator: KEMPER EAGLE
Run Date: 2-Jan-97 16:08

DSC

Sample: H2GG #20 NAALH4
Size: 1.5300 mg
Method: DSC 10°C/MIN.
Comment: 10°C/MIN@50 ML/MIN N2, AL HERPH

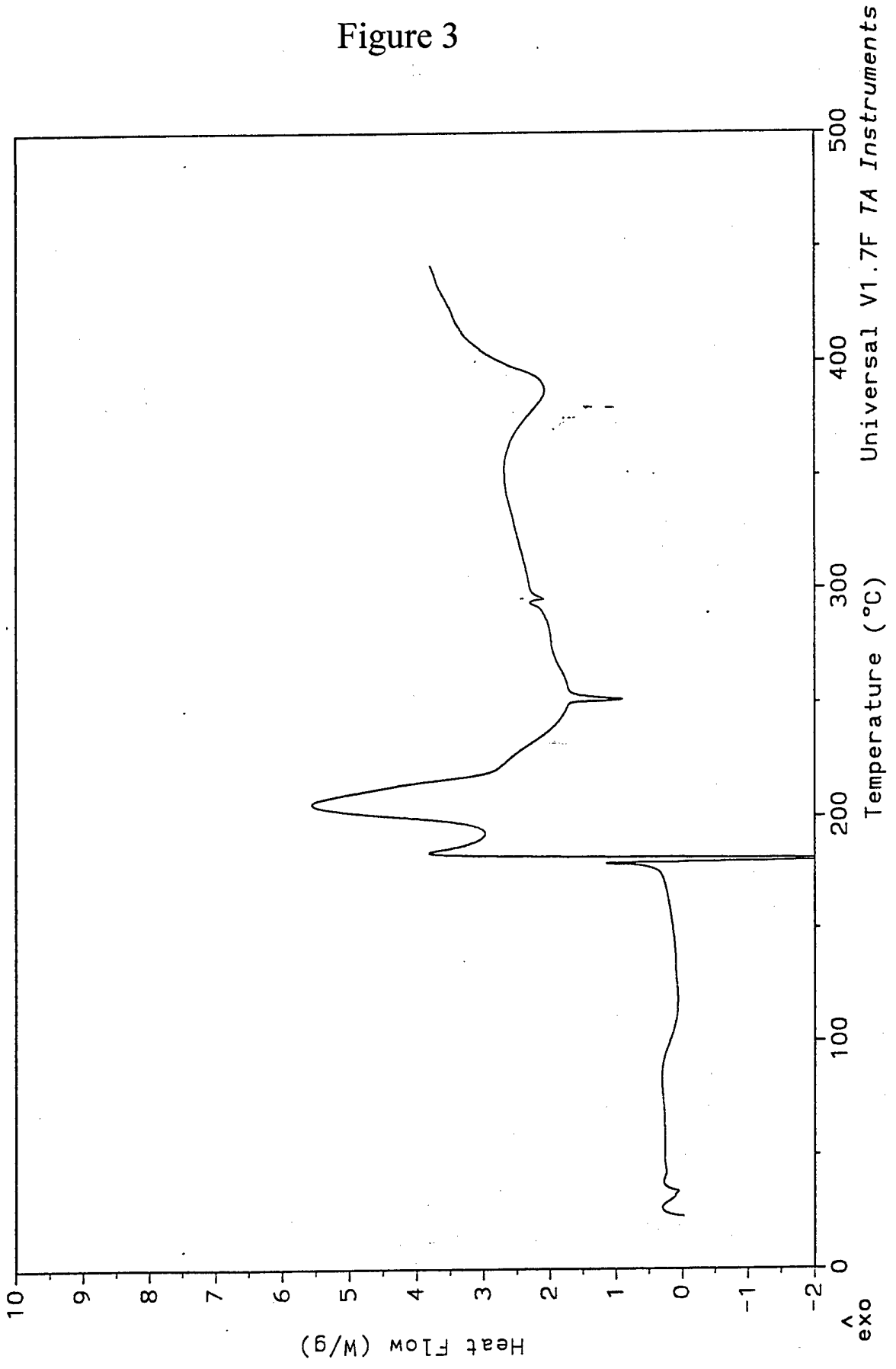

Figure 3

Sample: H2 GG: #8 MIX, NH4CL+LIALH4, #2 DSC
Size: 1.4700 mg
Method: DSC 10°C/MIN.
Comment: 10°C/MINØ50 ML/MIN N2, AL HERPH
File: C:H2GGACLA.82D
Operator: KEMPER EAGLE
Run Date: 6-Jan-97 17:25

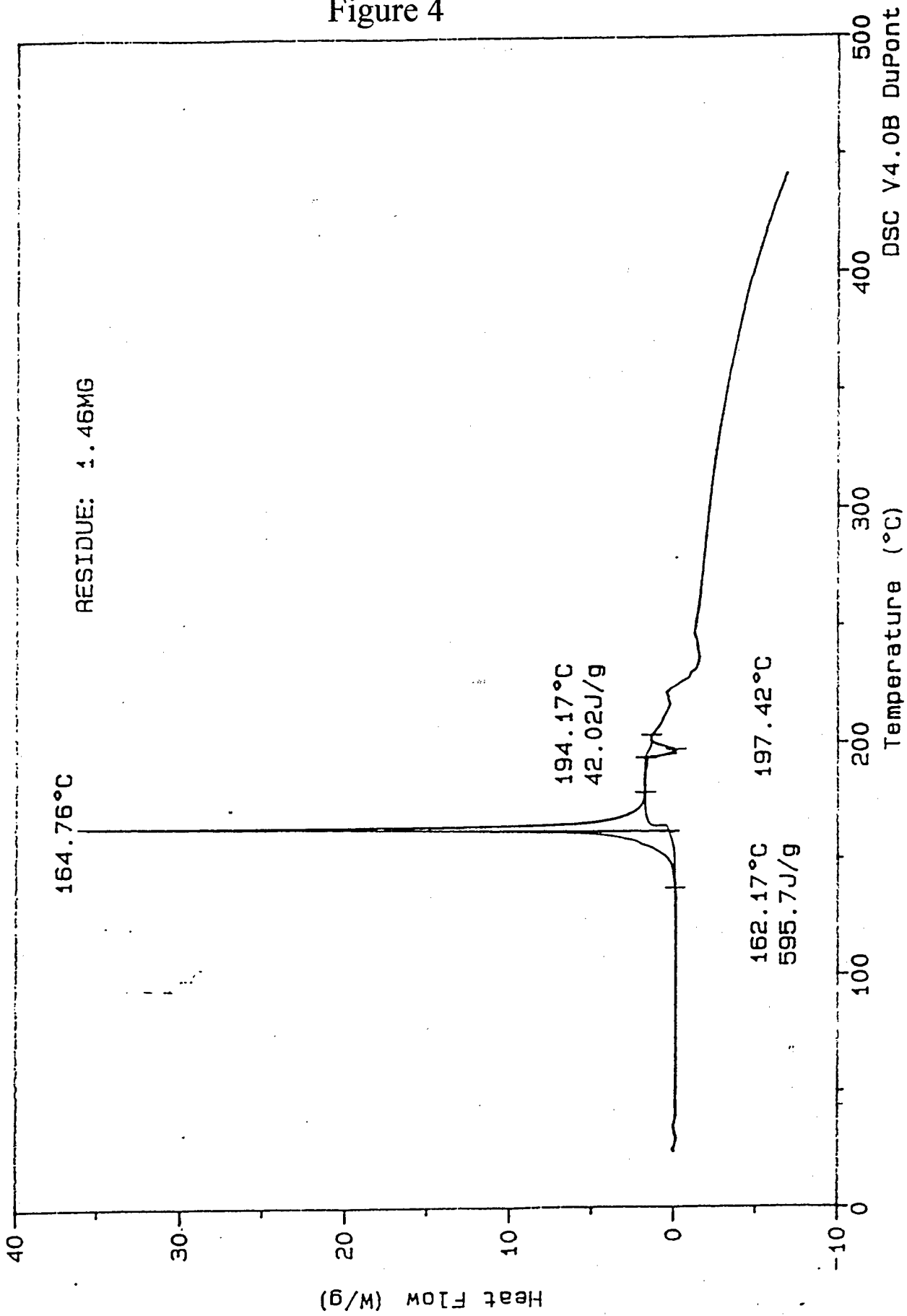

Figure 4

Sample: H2 GG: #26, NH4CL:LIALH4, 1:1
Size: 2.8300 mg
Method: H2 GG, CLIENT PROG
Comment: N2 @ 50 ML/MIN NO PIN HOLE

DSC

File: D:\TA\DSC\DATA\H2GG26AC.LAH
Operator: KEMPER EAGLE
Run Date: 19-Feb-97 15:13

Figure 5

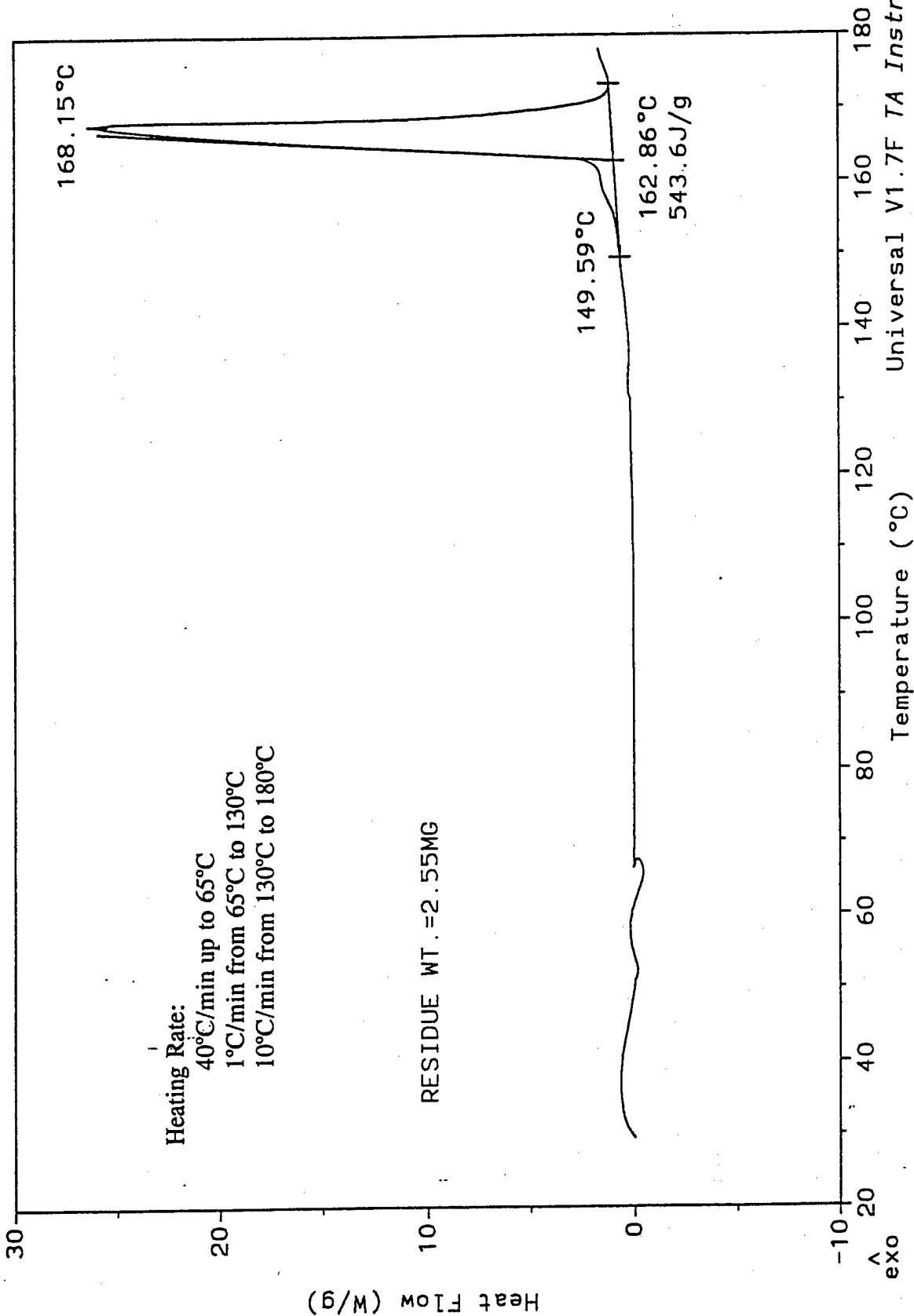
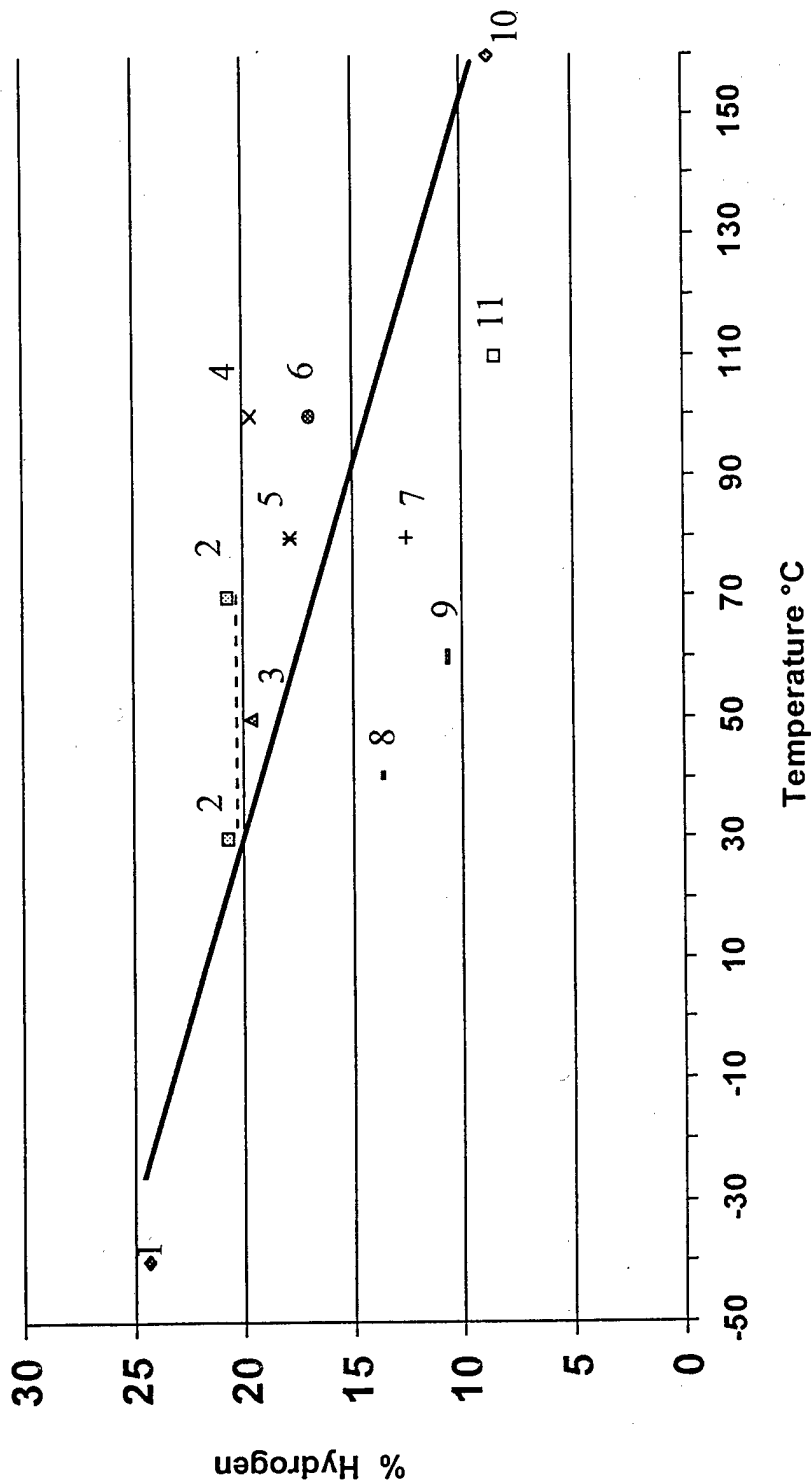

Figure 6. Hydrogen Yield vs. Thermal Stability



- | | | |
|---|---|---|
| 1. NH_4BH_4 (pure cpd) | 5. $\text{NH}_3\text{B}_3\text{H}_7$ (pure cpd) | 9. $\text{LiAlH}_4 + \text{NH}_4\text{F}$ (in formulation) |
| 2. $\text{NH}_4\text{B}_3\text{H}_8$ (pure cpd) | 6. $\text{N}_2\text{H}_4 \cdot 2\text{BH}_3$ (pure cpd) | 10. $\text{NaAlH}_4 + \text{NH}_4\text{Cl}$ (in formulation) |
| 3. NH_3BH_3 (pure cpd) | 7. $\text{Mg}(\text{BH}_4) \cdot 2\text{NH}_3$ (in formulation) | 11. $2\text{LiAlH}_4 + \text{NH}_4\text{Cl}$ (in formulation) |
| 4. $\text{BH}_2(\text{NH}_3)_2\text{BH}_4$ (pure cpd) | 8. $\text{LiBH}_4 + \text{NH}_4\text{F}$ (in formulation) | |

$\text{NH}_4\text{Cl} + 3 \text{LiAlH}_4 + 4\% \text{Kraton} + 4\% \text{Fe}_2\text{O}_3$

Sample: H2GG: "YES IRON"

Size: 2.6400 mg

Method: STANDARD DSC 10C/MIN

Comment: 10C/MIN. N2 @ 50 ML/MIN HER NOPH

DSC

File: D:\TA\DSC\DATA\H2GGYSFE.10D

Operator: DIANE ROBINSON

Run Date: 2-May-97 11:44

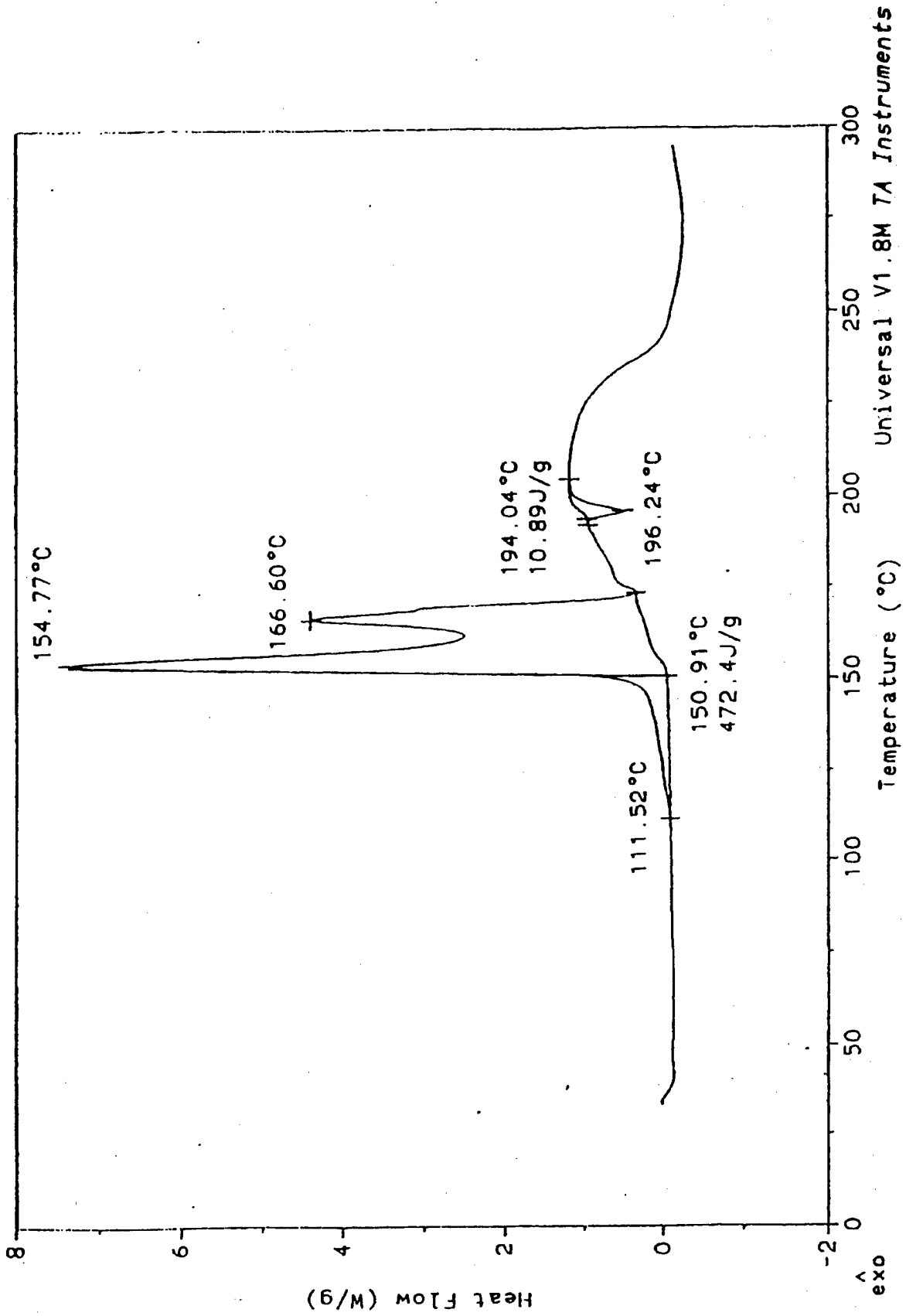

Figure 7

$\text{NH}_4\text{Cl} + 3 \text{LiAlH}_4 + 4\% \text{Kraton} + 4\% \text{Fe}_2\text{O}_3$

Sample: H2GG: "YES IRON"

Size: 14.0110 mg

Method: TGA 2°C/MIN.

Comment: 10°C/MIN. 80ML/MIN./N2. PT PAN. EQUILIBRATE @ 100°C/RAMP 2°C/MIN

TGA

File: C: H2GGYSFE.10T
Operator: DIANE ROBINSON
Run Date: 2-MAY-97 13:35

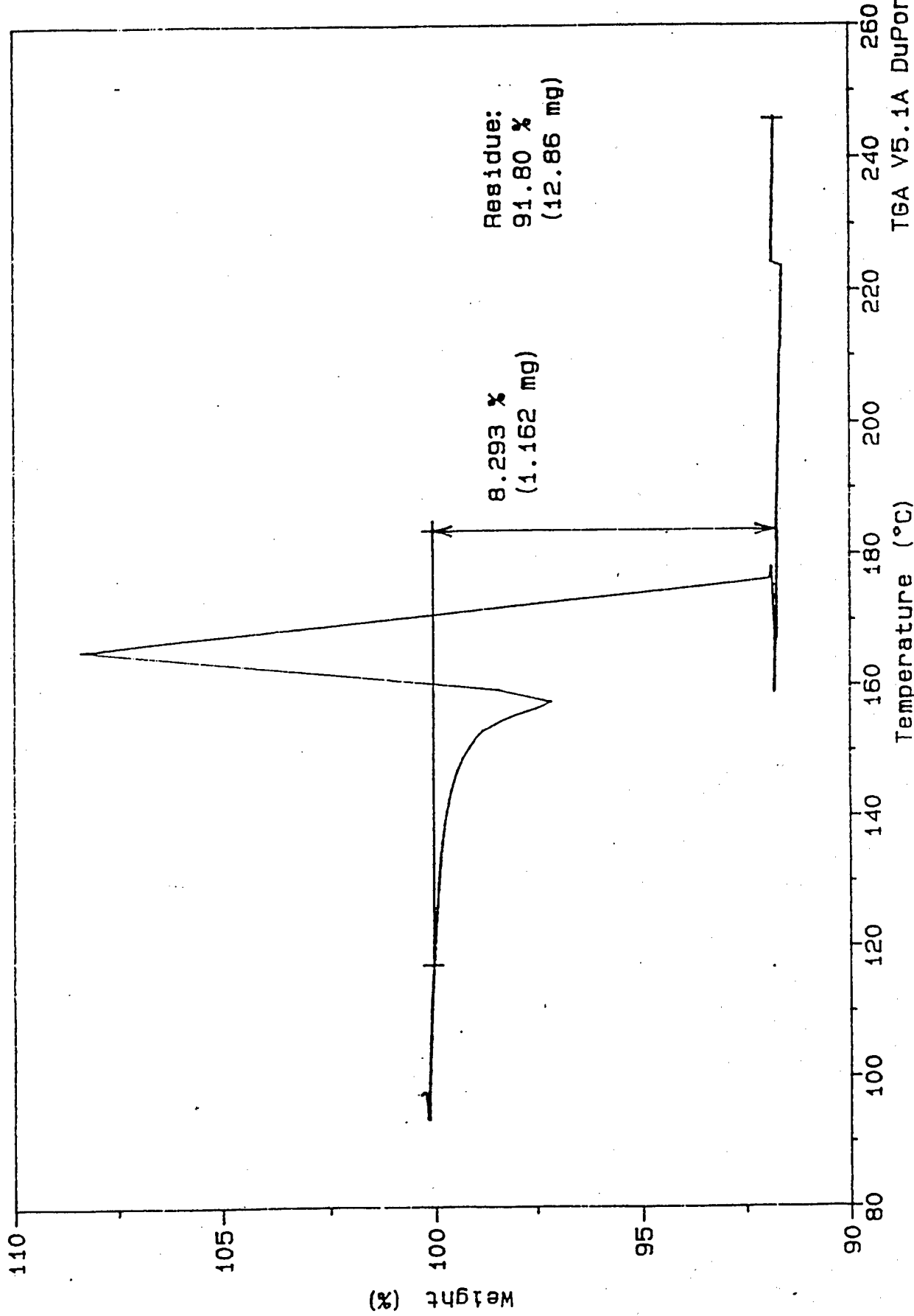

Figure 8

TGA V5.1A DuPont 2000

Differential Thermal Analysis

$\text{NH}_4\text{Cl} + 3 \text{LiAlH}_4 + 4\% \text{Kraton} + 4\% \text{Fe}_2\text{O}_3$

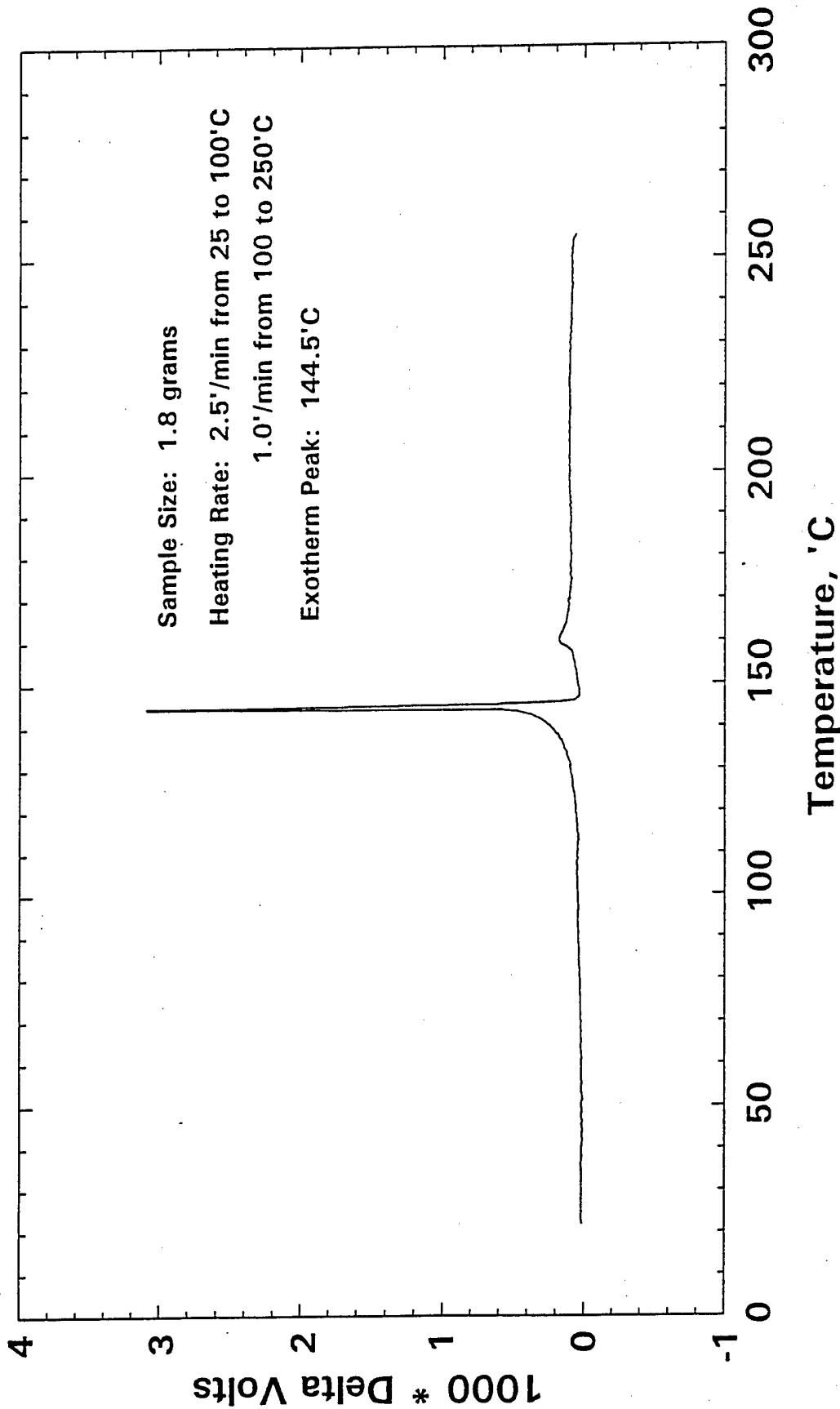

Figure 9

Differential Thermal Analysis

$\text{NH}_4\text{Cl} + 3 \text{LiAlH}_4 + 4\% \text{Kraton}$

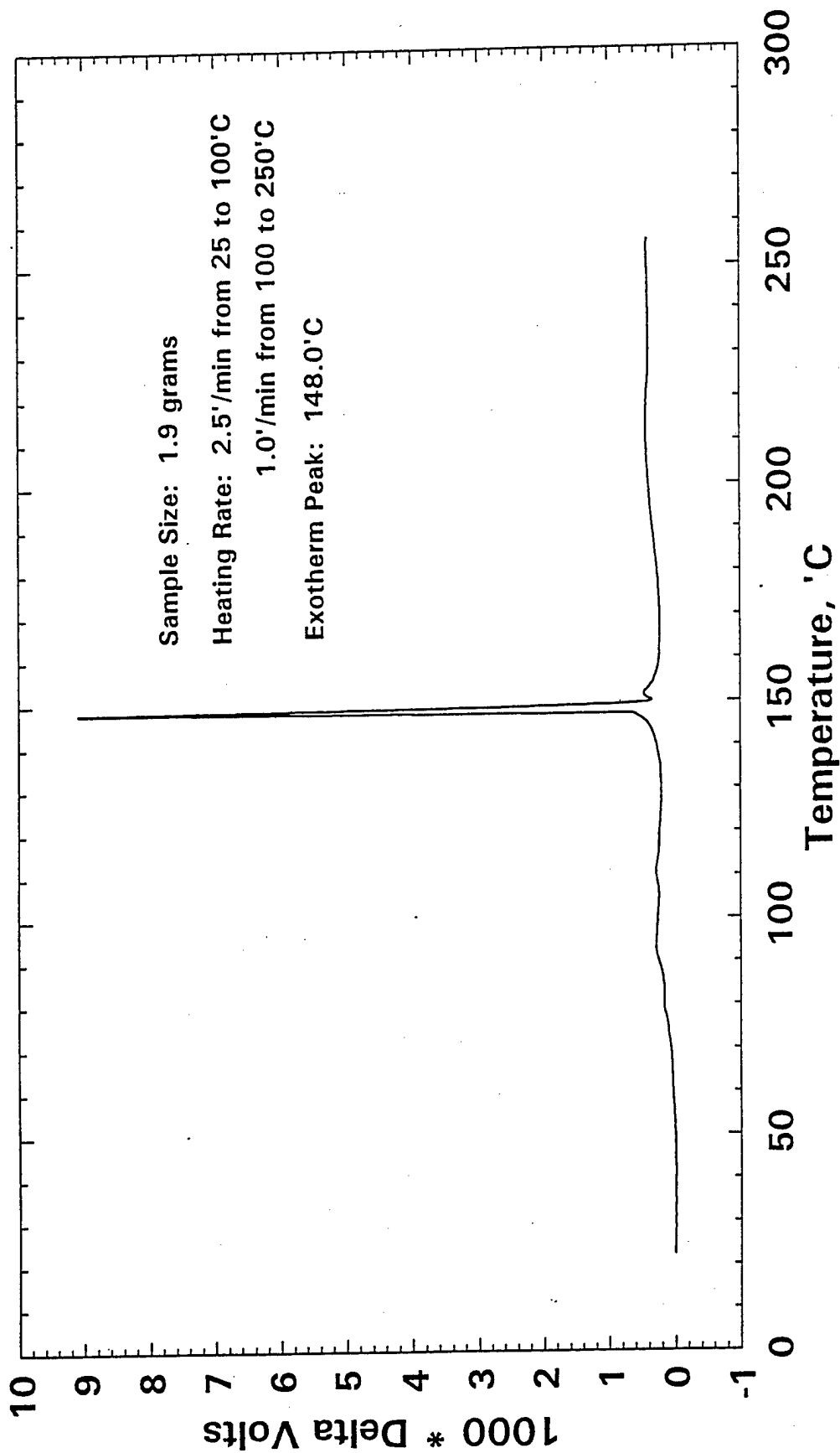

Figure 10

Figure 11
Hydrogen Gas-Generating System
(Royal Systems Design)

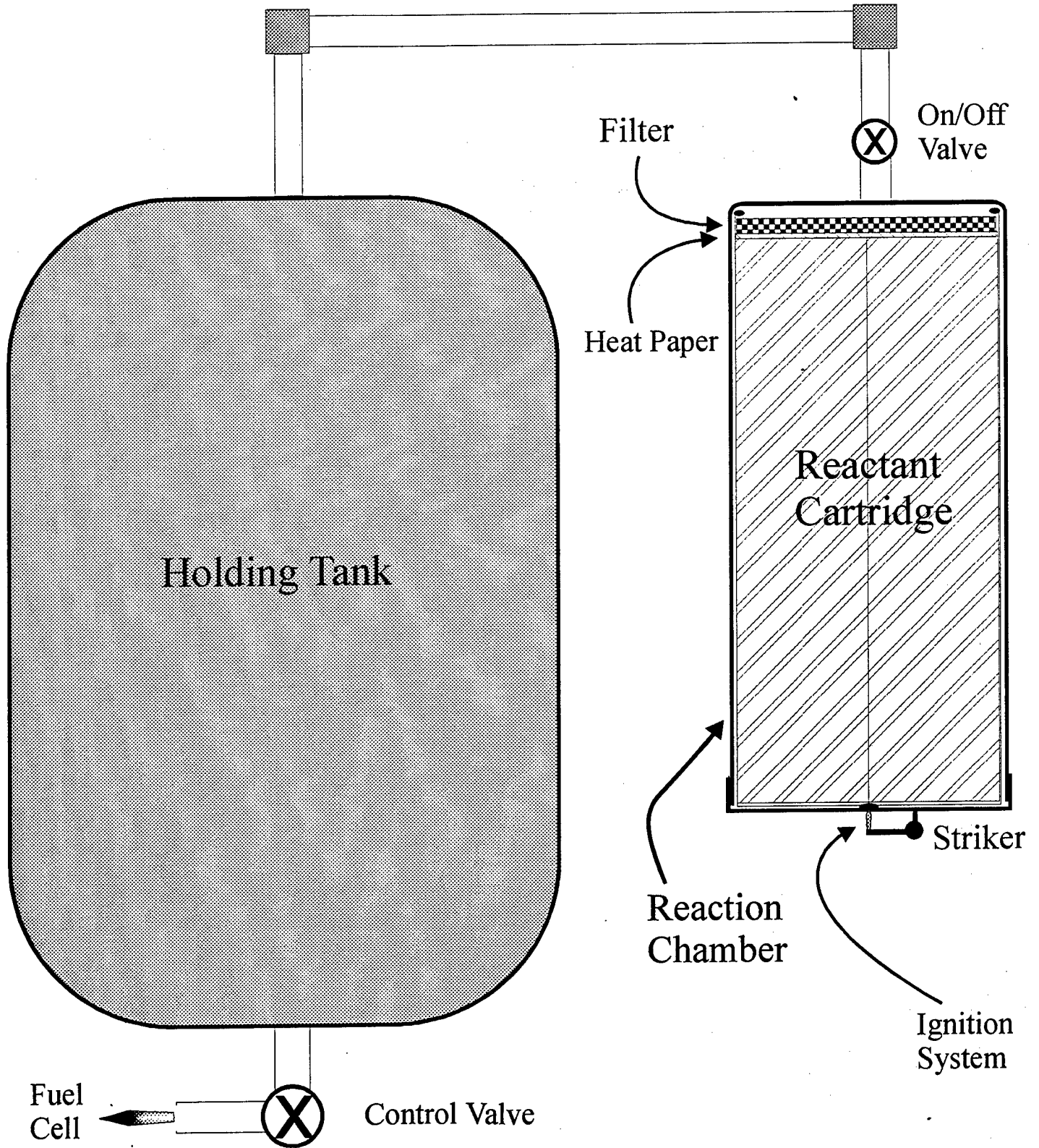
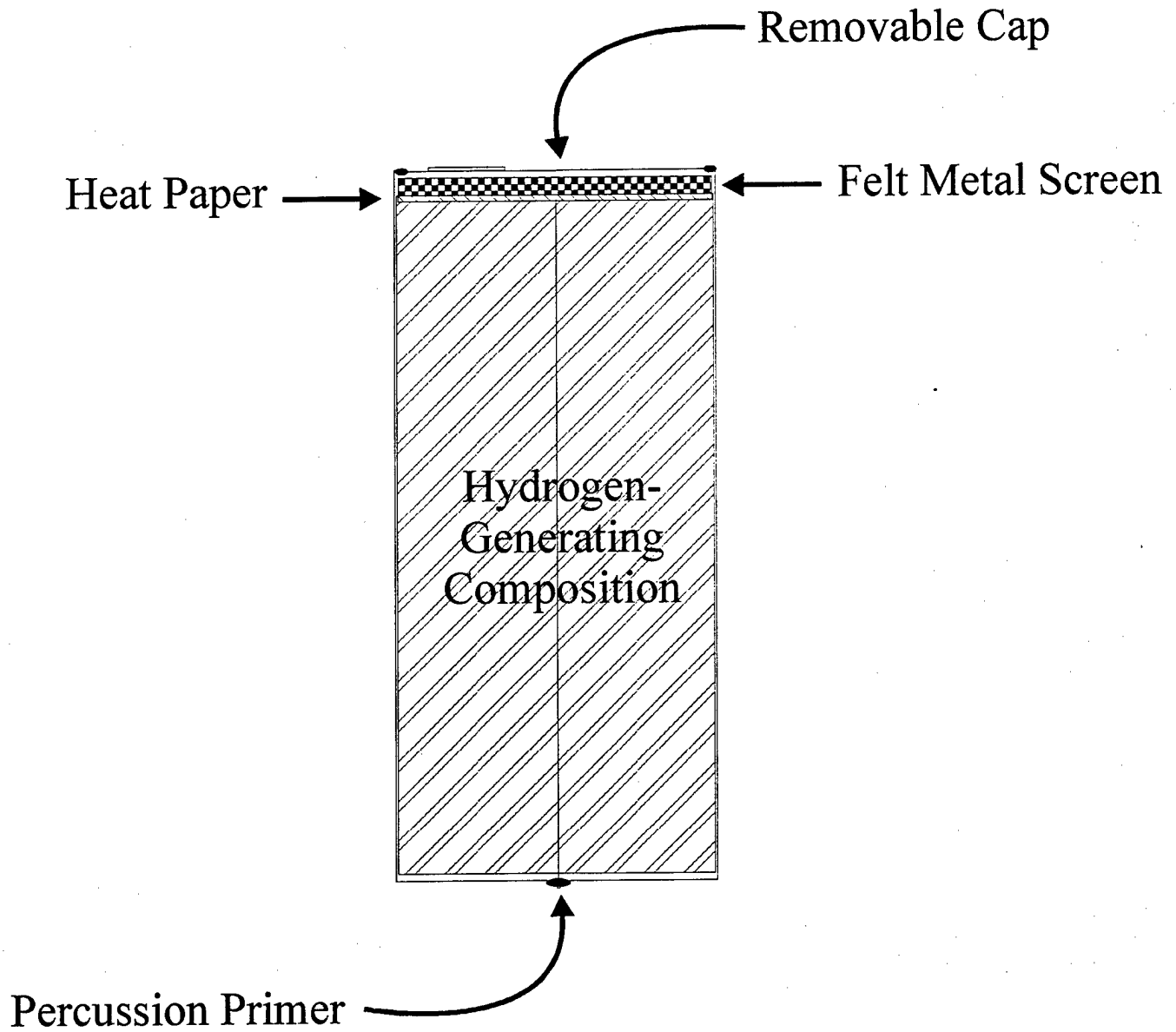

Figure 12
Reactant Cartridge
(Royal Systems Design)



NOTES:

1. REMOVE ALL SHARP EDGES AND BURRS.

PERCUSSION PRIMER

HYDROGEN GENERATING COMPOSITION

FILTER

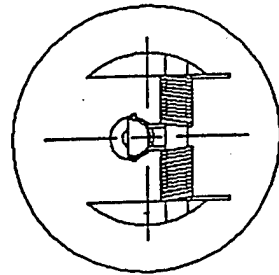

$\phi 1.520$

$\phi 1.77$

Figure 13

SEE DETAIL A-A

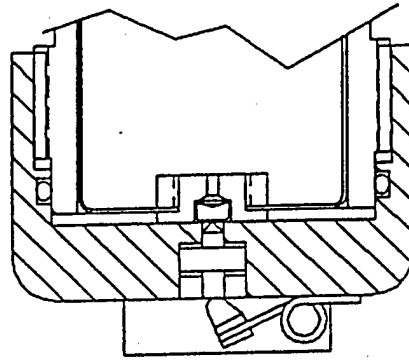

DETAIL A-A
SCALE 1.5/1

3.968

6.20

FILE NO.

UNLESS OTHERWISE SPECIFIED DIMENSIONS ARE IN INCHES	
DECIMALS	ANGULAR
.XX ±.01	±0.5
.XIX 1.000	
DO NOT SCALE THIS DRAWING	
DRAWN B.H.	DATE 2/97
CHECKED	
DESIGN	

Associated Design & Mfg.
Alexandria, Virginia 22314

108ml VESSEL

SIZE B	FCSJ NO. 50894	DWG NO. 2000-0514	REV B
SCALE 1/1	SHEET	OF	

Figure 14
System Weight vs. Reactant Weight
Hydrogen Gas-Generating System
 (Valves not included)

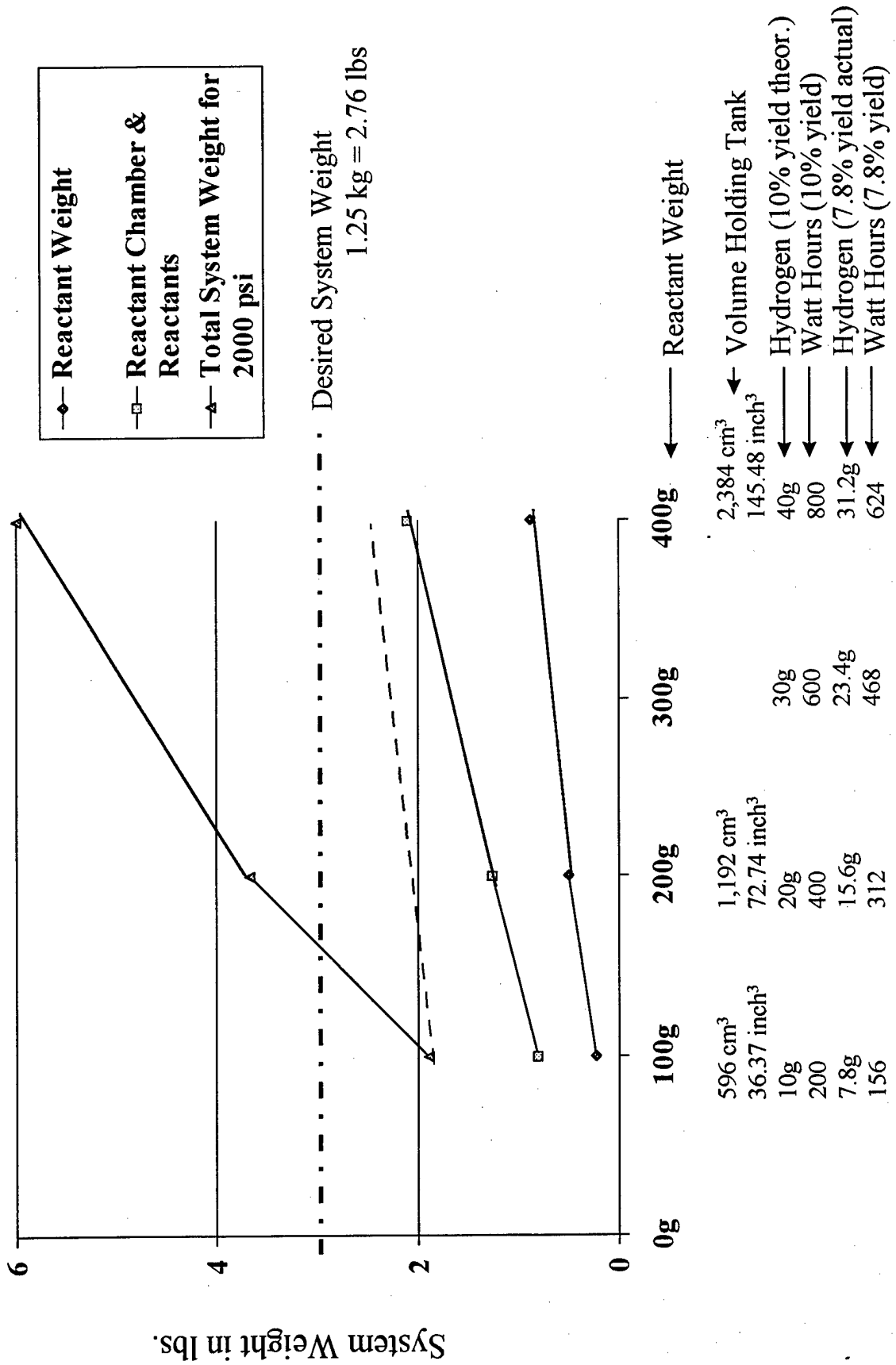

TABLE I
Properties of Hydrogen Generating Compositions¹

	H₂ - Generating Formulation	H₂ yield per reactant weight	Stability	Comments
1	NH ₄ BH ₄	24.4%	dec. -40°	unstable
2	NH ₄ B ₃ H ₈	20.7%	dec. 40° C	unstable
3	NH ₃ BH ₃	19.6%	dec. ~100°C/50° C	Mix: fine solids, high burn. rate, high T
4	BH ₂ (NH ₃) ₂ BH ₄	19.6%	dec. <95°C	Mix: fine solids, high burn rate, high T,
5	NH ₃ B ₃ H ₇	17.8%	dec. 74°C	unstable
6	N ₂ H ₄ • 2BH ₃	16.9%	dec. ~100°C	Mix: fine solids, high burn rate, el. stat.
7	Mg(BH ₄) ₂ • 2NH ₃	16.0%	dec. ~100°C	Mix: fine solids, high burn rate, high T, CO/NH ₃
8	Li + H ₂ O	4.0%	not stable	not pursued
9	LiH + H ₂ O	8.0%	not stable	not pursued
10	LiBH ₄ + H ₂ O	10.5%	not stable	not pursued
11	NH ₄ F + LiBH ₄	13.6%	dec. ~40°C	unstable (DSC); NH ₄ F toxicity
12	NH ₄ F + NaBH ₄	10.7%	dec. ~45°C	unstable (DSC); NH ₄ F toxicity
13	NH ₄ F + LiAlH ₄	10.7%	dec. 76°C	unstable (DSC); NH ₄ F toxicity
14	N ₂ H ₆ Cl ₂ + 2LiBH ₄	9.4%	no react. up to 400°C	
15	NH ₄ Cl + LiBH ₄	10.6%	dec. 60°C	unstable
16	NH ₄ F + NaAlH ₄	8.8%	dec. 107°C	not pursued - NH ₄ F toxicity
17	Li ₃ AlH ₆ + NH ₄ F	11.0%		compound not available; NH ₄ F toxicity
18	Li ₃ AlH ₆ + NH ₄ Cl	9.0%		compound not available
19	N ₂ H ₄ • 2BH ₃ + LiAlH ₄	13.0%		compound not available
20	N ₂ H ₄ • 2BH ₃ + MgH ₂	13.9%		compound not available
21	N ₂ H ₄ • 2BH ₃ + NH ₄ Cl + 3LiAlH ₄	10.3%		compound not available
22	NH ₄ Cl + 2LiAlH ₄	8.5%	dec. ~135°C (DTA)	acceptable formulation
23	NH ₄ Cl + NaAlH ₄	7.4%	dec. ~170°C (DTA)	very stable, relative low yield
24	NH ₄ Cl + 3LiAlH ₄	8.4%	dec. ~125°C (DTA)	recommended formulation
25	NH ₄ Cl + 1.2NaAlH ₄	7.3%	dec. ~160°C (DSC)	very stable, relative low yield
26	NH ₄ Cl + NaAlH ₄ + 2LiAlH ₄	7.6%	dec. ~125°C (DTA)	relative low yield

¹ The following materials are not commercially available: compounds in formulations 2-7; N₂H₄ • 2BH₃ in formulations 19-21; Li₃AlH₆ in formulations 17 and 18.

TABLE II
Physical Constants Used for Calculations

Compound	Mol. Wt.	MP, °C	BP, °C	Density g/cm ³	Δ H Kcal/mole	C _p /mole
NH ₄ F	37.04	subl.		1.01	-110.9	15.6
NH ₄ Cl	53.49	340°C subl.		1.53	-75.2	20.1
N ₂ H ₆ Cl ₂	104.97	198°C		1.42	-90.0	21.0
LiBH ₄	21.78	282°C dec		0.68	-46.4	18.3
NaBH ₄	37.83	300°C dec		1.08	-45.6	20.8
LiAlH ₄	37.95	125°C dec		0.92	-24.1	18.2
NaAlH ₄	54.0	183°C dec		1.24	-27.0	21.6
LiH	7.95	680°C		0.82	-21.6	8.3
LiF	25.94	842°C	1676°C	2.64	-144.7	8.2
LiCl	42.39	614°C	1325°C	2.07	-97.7	11.0
Li ₃ N	34.82	840°C		2(est)	-47.2	24.8(c)
NaF	41.99	988°C	1695°C	2.56	-136	10.4
NaCl	58.44	801°C	1413°C	2.17	-98.2	10.8
NaH	24.00			2(est)	-13.7	8.5(c)
BN	24.82	~3000°C		2.75	-60.8	1.63
Al	26.98	660°C	2467°C	2.70	0	5.80
AlN	40.99	>2200°C		3.26	-76	9.0
Al ₂ O ₃	101.96	2015°C	2980°C	3.5	-400.5	18.9
Al ₄ C ₃	143.96	>1400°C	2200°C d	2.36	-49.9	27.9
NH ₃	17.03	-77.7°C	-33.4°C	0.72x10 ⁻³	-11.0	8.4
Fe ₂ O ₃	159.69	1565°C		5.24	-197	24.8

(c) = calculated

(est) = estimated

TABLE III
Calculated Values for Formulations Under Consideration

Reaction Equation	ΔH Kcal	$\Delta H/\text{mole H}_2$	Theor. density before/after	Theor. Yield L/g	Theor. Yield g/100g
$\text{NH}_4\text{F} + \text{LiBH}_4 \rightarrow \text{LiF} + \text{BN} + 4\text{H}_2$	-48.2	-12.1	1.17/2.43	1.52	13.6
$\text{NH}_4\text{F} + \text{NaBH}_4 \rightarrow \text{NaF} + \text{BN} + 4\text{H}_2$	-40.3	-10.1	1.04/2.44	1.20	10.7
$\text{NH}_4\text{F} + \text{LiAlH}_4 \rightarrow \text{LiF} + \text{AlN} + 4\text{H}_2$	-85.7	-21.4	0.96/3.47	1.19	10.7
$\text{NH}_4\text{F} + \text{NaAlH}_4 \rightarrow \text{NaF} + \text{AlN} + 4\text{H}_2$	-74.1	-18.5	1.14/2.86	0.98	8.8
$\text{NH}_4\text{F} + 4\text{LiH} \rightarrow \text{LiF} + \text{Li}_3\text{N} + 4\text{H}_2$	+5.4	+1.4	0.91/2.23	1.30	11.6
$\text{NH}_4\text{Cl} + \text{LiBH}_4 \rightarrow \text{LiCl} + \text{BN} + 4\text{H}_2$	-36.9	-9.2	1.12/2.13	1.19	10.6
$\text{NH}_4\text{Cl} + \text{NaBH}_4 \rightarrow \text{NaCl} + \text{BN} + 4\text{H}_2$	-38.2	-9.6	1.30/2.20	0.98	8.8
$\text{NH}_4\text{Cl} + \text{LiAlH}_4 \rightarrow \text{LiCl} + \text{AlN} + 4\text{H}_2$	-74.4	-18.6	1.20/2.52	0.98	8.8
$\text{NH}_4\text{Cl} + \text{NaAlH}_4 \rightarrow \text{NaCl} + \text{AlN} + 4\text{H}_2$	-72.0	-18.0	1.37/2.52	0.83	7.4
$\text{NH}_4\text{Cl} + 4\text{LiH} \rightarrow \text{LiCl} + \text{Li}_3\text{N} + 4\text{H}_2$	+16.7	+4.2	1.16/2.04	1.05	9.4
$\text{N}_2\text{H}_6\text{Cl}_2 + 2\text{LiBH}_4 \rightarrow 2\text{LiCl} + 2\text{BN} + 7\text{H}_2$	-130.2	-18.6	1.08/2.13	1.06	9.4
$\text{N}_2\text{H}_6\text{Cl}_2 + 2\text{NaBH}_4 \rightarrow 2\text{NaCl} + 2\text{BN} + 7\text{H}_2$	-137.4	-19.6	1.25/2.19	0.87	7.5
$\text{N}_2\text{H}_6\text{Cl}_2 + 2\text{LiAlH}_4 \rightarrow 2\text{LiCl} + 2\text{AlN} + 7\text{H}_2$	-209.2	-29.9	1.16/2.52	0.87	7.7
$\text{N}_2\text{H}_6\text{Cl}_2 + 2\text{NaAlH}_4 \rightarrow 2\text{NaCl} + 2\text{AlN} + 7\text{H}_2$	-189.5	-27.1	1.32/2.52	0.74	6.6
$\text{N}_2\text{H}_6\text{Cl}_2 + 8\text{LiH} \rightarrow 2\text{LiCl} + 2\text{Li}_3\text{N} + 7\text{H}_2$	-26.9	-3.8	1.11/2.04	0.93	8.3
$\text{NH}_4\text{Cl} + 2\text{LiAlH}_4 \rightarrow \text{LiCl} + \text{AlN} + \text{LiH} + \text{Al} + 5.5\text{H}_2$	-71.9	-13.1	1.09/2.02	0.95	8.5
$\text{NH}_4\text{Cl} + 3\text{LiAlH}_4 \rightarrow \text{LiCl} + \text{AlN} + 2\text{LiH} + 2\text{Al} + 7\text{H}_2$	-69.4	-9.9	1.05/2.11	0.94	8.4
$\text{NH}_4\text{Cl} + 4\text{LiAlH}_4 \rightarrow \text{LiCl} + \text{AlN} + 3\text{LiH} + 3\text{Al} + 8.5\text{H}_2$	-66.9	-7.9	1.03/2.23	0.93	8.3
$\text{NH}_4\text{Cl} + \text{NaAlH}_4 + \text{LiAlH}_4 \rightarrow \text{NaCl} + \text{LiH} + \text{AlN} + \text{Al} + 5.5\text{H}_2$	-69.5	-12.6	1.21/2.18	0.85	7.6
$\text{NH}_4\text{Cl} + \text{NaAlH}_4 + 2\text{LiAlH}_4 \rightarrow \text{NaCl} + 2\text{LiH} + \text{AlN} + 2\text{Al} + 7\text{H}_2$	-67.1	-9.6	1.14/1.96	0.86	7.6
$\text{NH}_4\text{Cl} + \text{NaAlH}_4 + 3\text{LiAlH}_4 \rightarrow \text{NaCl} + 3\text{LiH} + \text{AlN} + 3\text{Al} + 8.5\text{H}_2$	-64.6	-7.6	1.1/1.8	0.86	7.7
$\text{NH}_4\text{Cl} + 1.2\text{NaAlH}_4 \rightarrow \text{NaCl} + \text{AlN} + 0.2\text{NaH} + 0.2\text{Al} + 4.3\text{H}_2$	-69.4	-16.1	1.34/2.49	0.81	7.3

TABLE IV
Hydrogen Gas-Generating Composition
Computer Calculation of Products

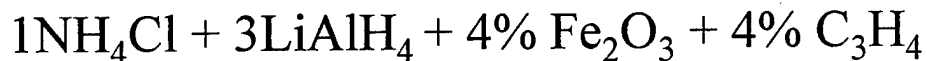

Reaction Chamber (number mols per 100g)

3.94546 H ₂	1.06299 LiH&	0.74429 Al&	0.54928 AlN&
0.54928 LiCl*	0.07967 Al ₄ C ₃ &	0.06049 CH ₄	0.05009 Fe&
0.03757 LiAlO ₂ &	0.00000 Li ₂ Cl ₂	0.00000 LiCl	0.00000 Li ₃ Cl ₃
7.2E-08 LiH	3.47E-08 Li	4.79E-11 H	2.96E-11 C ₂ H ₄
1.81E-11 AlH	1.42E-11 CH ₃	4.78E-12 AlCl	1.68E-12 Li ₂
1.37E-12 HCl	2.82E-14 Al	7.62E-15 NH ₃	

Exhaust Gas (number mols per 100g)

4.06313 H ₂	1.06299 LiH&	0.66584 Al&	0.54928 AlN&
0.54928 LiCl&	0.09929 Al ₄ C ₃ &	0.05009 Fe&	0.03757 LiAlO ₂ &
1.65E-03 CH ₄	1.43E-13 Li ₂ Cl ₂	8.03E-14 LiCl	1.55E-14 Li ₃ Cl ₃

Table V.
Weight Comparison for Reaction Chamber and Holding Tank
 (Designed for 2000 psi operating pressure)
 Material 6061 Aluminum

Weight of Reactants	Volume of Reaction Chamber	Weight of Reaction Chamber	Volume of Holding Tank	Weight of Holding Tank	Total System Weight
100g 0.22 lbs	108 cm ³ 6.63cu inch	0.55 lbs 5.7 kpsi*	596 cm ³ 36.37 cu inch	1.17 lbs 2.1 kpsi* (4" dia x 3" l)	0.22 0.55 <u>1.17</u> 1.94 lbs
200g 0.44 lbs	200 cm ³ 12.2 cu inch	0.87 lbs 5.6 kpsi*	1.192 cm ³ 72.74 cu inch	2.41 lbs 2.1 kpsi* (4" dia x 6" l)	0.44 0.87 <u>2.41</u> 3.72 lbs
400g 0.88 lbs	400 cm ³ 24.4 cu inch	1.2 lbs 3.6 kpsi*	2.384 cm ³ 145.48 cu inch	3.91 lbs 2.1 kpsi* (4" dia x 12" l)	0.88 1.20 <u>3.91</u> 5.99 lbs

* Maximum Pressure