

# REPORT DOCUMENTATION PAGE

Form Approved  
OMB No. 0704-0188

Public Reporting burden for collection of information is estimated to average 1 hour per response, including the time for reviewing instructions, searching existing data sources, gathering and maintaining the data needed, and completing and reviewing the collection of information. Send comment regarding this burden estimate or any other aspect of this collection of information, including suggestions for reducing the burden to Washington Headquarters Services, Directorate of Information Operations and Report, 1251 Jefferson David Highway, Suite 1204, Arlington, VA 22202-4302, and to the Office of Management and Budget, Paperwork Reduction Project (0704-0188) Washington, DC 20503.

1. AGENCY USE ONLY (Leave blank)	2. REPORT DATE <b>11/3/99</b>	3. REPORT TYPE AND DATES COVERED <b>06/01/97 - 10/31/99</b>
----------------------------------	----------------------------------	--

4. TITLE AND SUBTITLE <b>Resonant Tunneling Self-Assembled Quantum Dots for Memory Elements</b>	5. FUNDING NUMBERS <b>DAAG55-97-1-0301</b>
6. AUTHOR(S) <b>Pierre M. Petroff</b>	

7. PERFORMING ORGANIZATION NAME(S) AND ADDRESS(ES) <b>Materials Department College of Engineering University of California Santa Barbara, CA 93106-5050</b>	8. PERFORMING ORGANIZATION REPORT NUMBER
--	--

9. SPONSORING/MONITORING AGENCY NAME(S) AND ADDRESS(ES) <b>U. S. Army Research Office P. O. Box 1221 Research Triangle Park, NC 27709-2211</b>	10. SPONSORING/MONITORING AGENCY REPORT NUMBER  <b>ARO 35917.4-PH</b>
---	---

11. SUPPLEMENTARY NOTES  
The view, opinions and/or findings contained in this report are those of the author(S) and should not be construed as an official Department of the Army position, policy or decision, unless so designated by other documentation.

12A. DISTRIBUTION/AVAILABILITY STATEMENT <b>Approved for public release; distribution unlimited.</b>	12B. DISTRIBUTION CODE
---	------------------------

13. ABSTRACT (Maximum 200 words)  
This report covers 2 years of activity starting June, 1997(start up date of the contract) to October 31, 1999. Two main research topics were studied during this period: 1. Research on buried strain induced quantum dots (SIQDs) generated by self assembling quantum dot (QDs) layers. We investigated here a new type of quantum dots which are generated by the lateral band gap modulation of a quantum well GaAs/AlGaAs induced by a buried layer of self assembled quantum dots. Such SIQDs allow to move the OD confinement regime into the red region of the spectrum. The confinement energies for these SIQDs are function of the distance between the QDs layer and the QW and on the thickness of the QW. They also allow for a greater flexibility for integrating quantum dot devices in device structures.  
To this end, we have developed an exciton storage device based on quantum dot structures. The device uses pairs of SIQDs and QDs to store the exciton dissociated as an electron-hole pair under an internal electric field. The stored e-h pair is restored as an exciton by applying a bias to the device. This method allows for exciton lifetimes of several seconds i.e. more than a billion times the lifetimes of excitons in normal QDs.

14. SUBJECT TERMS  <div style="text-align: center; font-size: 2em; font-weight: bold;">19991215 043</div>	15. NUMBER OF PAGES  <div style="text-align: center; font-size: 1.5em; font-weight: bold;">14</div>
	16. PRICE CODE

17. SECURITY CLASSIFICATION OF REPORT <b>Unclassified</b>	18. SECURITY CLASSIFICATION OF THIS PAGE <b>Unclassified</b>	19. SECURITY CLASSIFICATION OF ABSTRACT <b>Unclassified</b>	20. LIMITATION OF ABSTRACT <b>UL</b>
--	---	--	---

## **REPORT ON ARO CONTRACT #DAAG55-97-1-0301**

### **Resonant Tunneling Self Assembled Quantum Dots for Memory Elements.**

#### **ABSTRACT:**

This report covers 2 years of activity starting June, 1997(start up date of the contract) to October 31, 1999. Two main research topics were studied during this period: 1. Research on buried strain induced quantum dots (SIQDs) generated by self assembling quantum dot (QDs) layers. We investigated here a new type of quantum dots which are generated by the lateral band gap modulation of a quantum well GaAs/AlGaAs induced by a buried layer of self assembled quantum dots. Such SIQDs allow to move the OD confinement regime into the red region of the spectrum. The confinement energies for these SIQDs are function of the distance between the QDs layer and the QW and on the thickness of the QW. They also allow for a greater flexibility for integrating quantum dot devices in device structures.

To this end, we have developed an exciton storage device based on quantum dot structures. The device uses pairs of SIQDs and QDs to store the exciton dissociated as an electron-hole pair under an internal electric field. The stored e-h pair is restored as an exciton by applying a bias to the device. This method allows for exciton lifetimes of several seconds i.e. more than a billion times the lifetimes of excitons in normal QDs.

## **FINAL PROGRESS REPORT:**

### **1) FOREWORD:**

This report covers 2 years of activity starting November 1997 (start up date of the contract) to October 30 1999. Two main research topics were studied during this period: 1) research on buried strain induced quantum dots (SIQDs) generated by self assembling quantum dot (QDs) layers. We investigated here a new type of quantum dots which are generated by the lateral band gap modulation of a quantum well GaAs/AlGaAs induced by a buried layer of self assembled quantum dots. Such SIQDs allow to move the 0D confinement regime into the red region of the spectrum . The confinement energies for these SIQDs are function of the distance between the QDs layer and the QW and on the thickness of the QW. They also allow for a greater flexibility for integrating quantum dot devices in device structures.

To this end , we have developed an exciton storage device based on quantum dot structures. The device uses pairs of SIQDs and QDs to store the exciton dissociated as an electron-hole pair under an internal electric field. The stored e-h pair is restored as an exciton by applying a bias to the device. This methods allows for exciton lifetimes of several seconds i.e. more than a billion times the lifetimes of excitons in normal QDs.

### **2) TABLE OF CONTENTS:**

ABSTRACT	1
FOREWORD	2
LIST OF FIGURES	3
STATEMENT OF PROBLEM	4
SUMMARY OF MOST IMPORTANT RESULTS	4
A) STRAIN INDUCED QUANTUM DOTS	4
B) EXCITON STORAGE IN QUANTUM DOTS	8
LIST OF PUBLICATIONS	13
LIST OF PERSONEL	14

### 3) ILLUSTRATION AND TABLE LISTS:

**Figure 1:** Band diagram schematic of the charge separation process.

**Figure 2:** Photoluminescence spectra of the quantum dots sample. Spectra were taken at  $T = 3\text{K}$  with a  $\text{Ar}^+$  laser pump power of  $150\text{ W/cm}^2$ . Inset shows origin of PL peaks in the spectra.

**Figure 3:** Power dependent photoluminescence spectra for the QDs and reference samples.

**Figure 4:** Dependence of the integrated intensities of the QDs and SIQDs PL peaks on applied bias. Data was taken at  $T = 3\text{K}$  with an  $\text{Ar}^+$  laser power of  $250\text{ W/cm}^2$ .

**Figure 5:** An electron hole pair generated by optical pumping is shown. The electron is localized and stored in the InAs QD while the hole is stored in the SIQD directly above the QD. (B) Cross sectional TEM micrograph shows the strain contrast around the buried InAs QD and in the GaAs QW.

**Figure 6:** (A) Low temperature photoluminescence spectra of the QD memory sample for increasing pump powers ( $0.32, 1.3, 6.4, 12\text{ kW/cm}^2$ ). (B) Schematic band diagram showing the radiative transitions from the QDs (line A) and the spatially indirect recombination involving the SIQDs (line B).

**Figure 7:** Time resolved luminescence from the QDs detected at  $1.25\text{eV}$ . (A) Writing the QD memory with a  $2\text{ }\mu\text{J}$  laser pulse at  $3\text{K}$  and reading with a short  $0.5\text{V}$  positive bias pulse. (B) No laser pulse but the same readout bias pulse.

**Figure 8:** Low temperature ( $3\text{K}$ ) integrated intensity of the read out signal as function of time for a forward bias of  $0.5\text{V}$ . The lines are exponential fits to the data. The storage time extrapolated to the average noise level (on this scale is  $6.10^{-3}$ ) is  $\sim 10$  seconds.

#### **4) STATEMENT OF PROBLEM STUDIED:**

##### **A) STRAIN INDUCED QUANTUM DOTS:**

We have developed a novel InAs self-assembled quantum dot structure designed to spatially separate and store photo-generated electron-hole pairs. The structure consists of pairs of strain coupled quantum dots. The separation of the electron-hole pairs into the quantum dots and strain-induced quantum dots is detected by power-dependant photoluminescence and bias-dependent photoluminescence. The resulting electric field should be detected by a blue shift of the photoluminescence signal associated with the SIQDs.

##### **B) EXCITON STORAGE DEVICE:**

The purpose of the work is to develop an all optical memory which will use the QDs and SIQDs as a storage medium. We study here the use of strain induced quantum dots (SIQDs)-QDs structure to dissociate the exciton into an e-h pair which is then stored with the electron in the QD and the hole into its associated SIQD. The e-h pair localization should be reflected in giant carrier lifetimes.

#### **5) SUMMARY OF THE MOST IMPORTANT RESULTS:**

##### **A) STRAIN INDUCED QDs AND QDs STRUCTURES FOR SEPARATING CHARGES.**

In this work we introduce a new QDs device designed to spatially separate and store photo-generated electron-hole pairs. The structure consists of two GaAs quantum wells (QW) of different thickness, separated by a thin AlAs barrier. An InAs QDs layer is inserted in the thick QW to allow carrier localization within the device. The InAs QDs layer also creates strain-induced quantum dots (SIQDs) within the thin GaAs QW that are coupled to the InAs QDs. In the structure photo-generated electrons and holes are spatially separated into the InAs QDs and SIQDs, respectively (see Fig. 1).

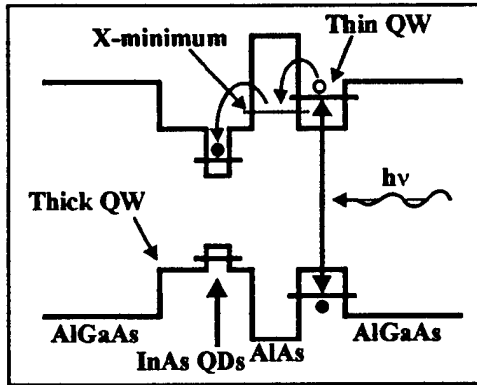
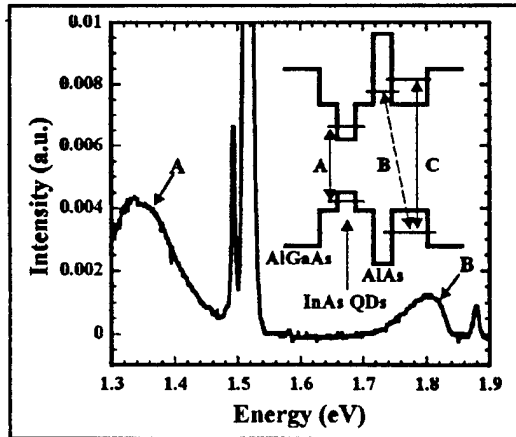

**Fig. 1:** Band diagram schematic of the charge separation process.

An incident photon pulse creates electron-hole pairs within the thin QW. The thickness of the GaAs QWs are selected such that their first electron state is either above (for the thin QW) or below (for the thick QW surrounding the InAs

QDs layer) the X-band minimum of the AlAs barrier. Electrons are able to tunnel into the InAs QDs from the thin GaAs QW through the X-band minimum, while the respective holes remain in the thin QW since there is no intermediate tunneling route available for holes.

A typical photoluminescence spectra of a QDs sample is shown in Figure 2. A typical QDs peak is present at about 1.32eV in the PL spectra of the QDs sample (transition A of inset in Fig. 2).



**Fig. 2:** Photoluminescence spectra of the quantum dots sample. Spectra were taken at  $T = 3\text{K}$  with a  $\text{Ar}^+$  laser pump power of  $150 \text{ W/cm}^2$ . Inset shows origin of PL peaks in the spectra.

As expected, PL spectra from the reference sample did not contain such a peak. The strong PL lines around 1.51 eV originate from

the GaAs buffer layer in the sample. The broad peak (FWHM = 72 meV) observed at  $\sim 1.8 \text{ eV}$  comes from the SIQDs (transition B). This peak is associated with an indirect type II recombination between electrons in the AlAs X-minimum and heavy holes in the  $25 \text{ \AA}$  QW. Previous PL studies on AlAs/GaAs superlattices have demonstrated strong luminescence from such a spatially indirect recombination due to the ultra fast transfer ( $\sim 0.4 \text{ psec}$ ) of electrons from the GaAs QW to the X-band minimum in the AlAs. The SIQDs arise from strain fields above the InAs QDs. The piezopotential bandgap modulation resulting from the strain field and the strain induced deformation potential

induce carrier localization in the 25Å QW. Results obtained from theoretical calculations of the piezoelectric and deformation potentials for a 25Å GaAs QW that is 100Å above an InAs QD are consistent with the energy reductions observed for the SIQDs luminescence, relative to an unstrained 25Å QW. The width of the 1.8 eV PL peak is due to the SIQDs size distribution induced by the size distribution of the InAs QDs. A sharper peak (FWHM = 18 meV) at 1.85 eV was observed in the reference sample PL spectra, corresponding to the same type-II recombination. The decreased line width of this peak indicates the absence of SIQDs within the reference sample, as expected. The power dependent photoluminescence (PDPL) spectra of the SIQDs are shown in Figure 3a.

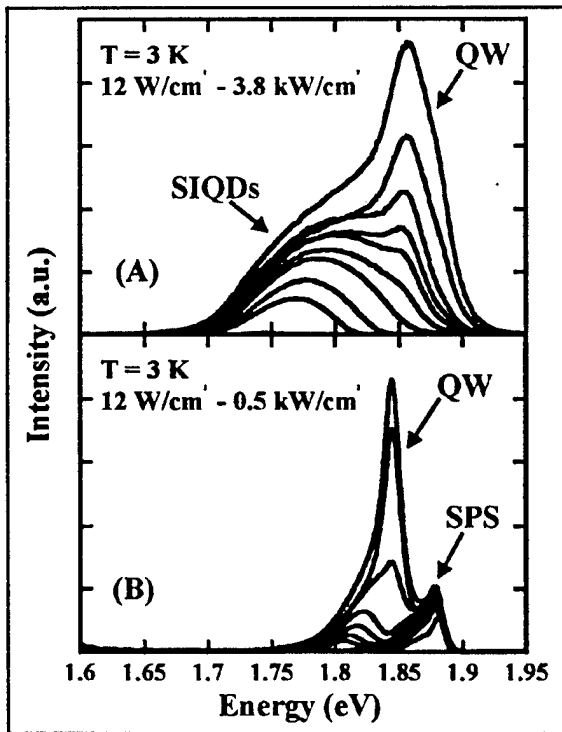

Fig. 3: Power dependent photoluminescence spectra for the QDs and reference samples.

For increasing pump powers between 12 W/cm<sup>2</sup> and 3.8 kW/cm<sup>2</sup> the SIQDs peak blue shifts 50 meV. At a pump power of 2.2 kW/cm<sup>2</sup>, the direct recombination of electrons and heavy holes in the 25Å QW (transition C in Fig. 2) begins to dominate over the SIQDs luminescence. A similar dependence on pump power is observed in the PDPL from the reference sample (Figure 3b). The PL peak from the indirect

recombination is found to shift 50 meV for increasing pump power between 12 W/cm<sup>2</sup> and 0.5 kW/cm<sup>2</sup>. As observed in the PDPL of the SIQDs from the QDs sample, the direct recombination from the 25Å QW begins to dominate at high pump powers (380 W/cm<sup>2</sup>). The blue shift in the SIQDs peak for increasing pump powers comes from: (a) an increased filling of the higher energy SIQDs (FWHM increases from 40 to 90 meV) and (b) an increase in the band bending in the structure due to a greater number of electron-hole dipoles. In contrast, the only contribution to the blue shift in the reference sample

PDPL is the increase in the number of electron-hole separations for increased pump powers. Thus, the PDPL data indicate that the structure is able to efficiently separate photo-generated electron-hole pairs into the coupled QDs.

In both the QDs and reference sample PDPL spectra, a saturation of the spatially-indirect type-II recombination occurs. This is due to the dipole-induced band bending within the structure, which increases for larger pump powers. The increased dipole strength for higher pump powers causes an increased band bending which decreases the efficiency of transfer of the electrons from the 25Å QW to the InAs QDs. At high pump powers the quasi-Fermi level in the SIQDs increases sufficiently to give rise to the direct recombination within the 25Å QW.

In order to further investigate the carrier separation kinetics of this structure, bias dependent PL (BPL) measurements were performed. The integrated intensity dependence of the SIQDs and QDs peaks on applied bias is shown in Figure 4.

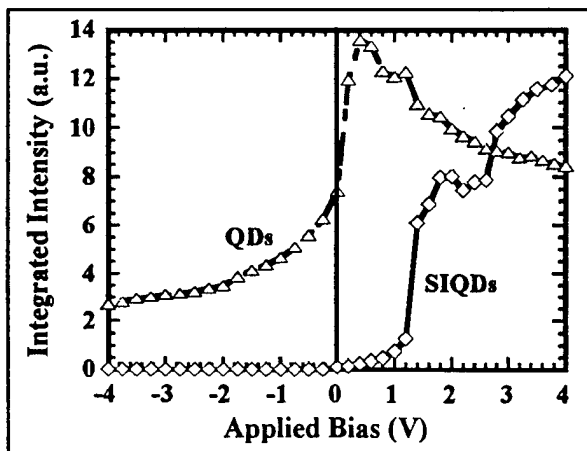

Fig.4 : Dependence of the integrated intensities of the QDs and SIQDs PL peaks on applied bias. Data was taken at  $T = 3\text{K}$  with an  $\text{Ar}^+$  laser power of  $250 \text{ W/cm}^2$ .

For negative biases, no SIQDs luminescence is observed. This is due to the highly efficient transfer of electrons

out of the 25Å QW into the InAs QDs. For negative biases a PL peak is observed for the QDs. This peak increases in intensity for decreasing negative applied bias. For the negative biases, electrons and holes are swept away by the applied electric field, giving rise to a measurable photocurrent. As the negative bias is decreased towards 0.0 V, a reduced number of carriers are swept away, leading to a decreased photocurrent and an increased QDs luminescence.

As the applied bias is increased above 0.0 V, the QDs luminescence continues to increase for applied biases up to ~0.7 V, at which point it slowly drops for increased biases.

Conversely, the SIQDs peak intensity rises quickly above ~0.7 V up to 1.8 V. This

behavior is due to the bias-induced band bending within the structure. As stated above, for applied biases between  $-3.0$  and  $-0.7$  V, electron transfer into the QDs from the SIQDs is very efficient. As the applied bias is increased above  $0.7$  V, the efficiency of the electron transfer is reduced, giving rise to an increase in the SIQDs luminescence and a reduction in the QDs PL intensity.

The BPL data indicates that not only is there efficient separation of the photo-generated electron-hole pairs, but that there may also be a regime for which an applied bias pulse can be used to cause tunneling of the holes from the  $25\text{\AA}$  QW into the QDs layer to induce the electron-hole recombination. This effect could be used for reading the stored charges in a QDs memory structure.

#### B) DEVELOPMENT OF A QDs BASED EXCITON STORAGE MEDIUM:

We have demonstrated the storage and retrieval of excitons with semiconductor self assembled quantum dots. The optically generated excitons are dissociated and stored as separated electron-hole pairs into coupled quantum dot pairs. A bias voltage restores the excitons which recombine radiatively to provide a read out optical signal. The localization of the spatially separated electron hole pair in quantum dots is responsible for the ultra long storage times which are in the order of several seconds. The present limits of this optical storage medium are discussed.

The semiconductor quantum dots (QDs) are produced by using molecular beam epitaxy (MBE). The size of the lens shape QDs ( $\sim 30\text{-}40$  nm diameter,  $\sim 3\text{-}5$  nm height) is on the order of the electron wavelength and the carrier energy levels are quantized. The sequential loading of electrons and holes and the three dimensional confinement character of the carriers in the QDs have been demonstrated. The sharp density of states yields ultra narrow luminescence lines and several studies have recently shown the importance and complexity of many body effects in the relaxation processes involved in strongly excited quantum dots.

The QDs device structure presented here is based on the splitting of an optically generated exciton into an electron-hole pair for the write cycle. The electron and hole are stored into closely spaced strain coupled QDs pairs. The effects of this strain coupling is to locally lower the band gap of the material and localize the electron-hole pair. After storing for a given time, an applied voltage bias brings the electron and hole together in the same QD where they recombine radiatively for the read out cycle.

The central part of the device structure contains an InAs QD layer and a narrow GaAs QW separated by a thin AlAs layer. The 7% lattice mismatch between InAs and GaAs creates a strain field around the coherently strained InAs QDs. This strain field extends through the thin AlAs barrier into the narrow GaAs QW where it creates a buried strain induced quantum dot (SIQD). The cross section transmission electron micrograph ( Fig. 5)

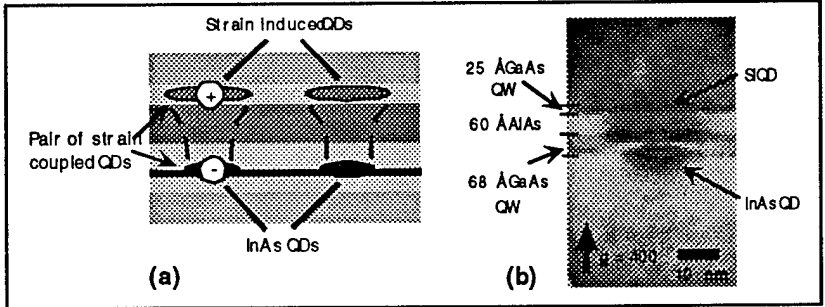

Fig. 5: (A) Schematic of the QD memory structure showing pairs of strain coupled QDs and SIQDs. An electron hole pair generated by optical pumping is shown. The electron is localized and stored in the InAs QD while the hole is

stored in the SIQD directly above the QD. (B) Cross sectional TEM micrograph shows the strain contrast around the buried InAs QD and in the GaAs QW.

indicates that the strain field of the InAs QD extends to the GaAs QW where it gives rise to a strain contrast. The QW thickness is chosen to insure that its lowest electron energy level is above the X valley minimum in the AlAs barrier. This approach allows one to engineer the ladder of electronic levels shown Fig. 6.

The cascaded energy level structure insures that under the influence of an electric field the excitons created in the QW are efficiently separated into electron-hole pairs. The relaxation of the electron from the SIQD to the X valley is a rapid process occurring in a few picoseconds as was shown for the case of QW structures. Further relaxation of the electron into the InAs QDs should also take place rapidly by tunneling and / or thermal excitation. In a quantum well structure, these relaxation processes were shown to be taking place in 30psec.

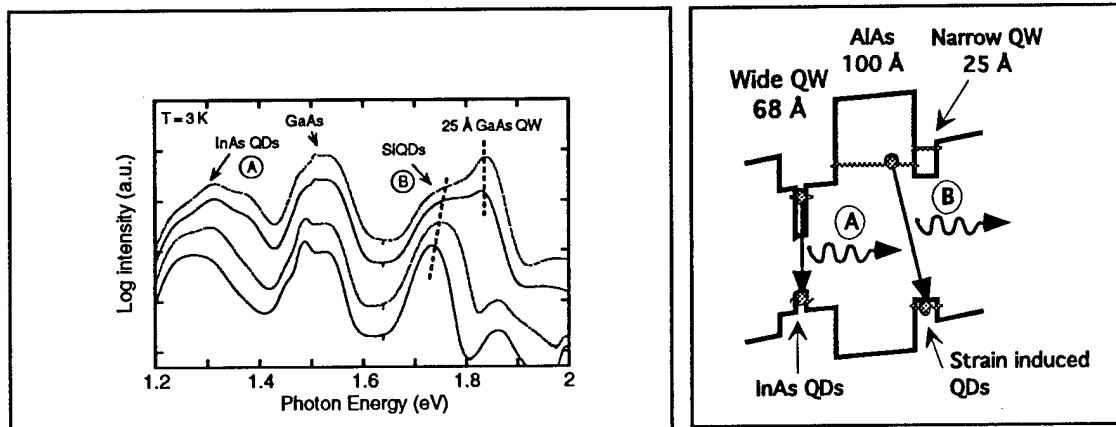

Fig. 6: (A) Low temperature photoluminescence spectra of the QD memory sample for increasing pump powers (0.32, 1.3, 6.4, 12 kW/cm<sup>2</sup>). (B) Schematic band diagram showing the radiative transitions from the QDs (line A) and the spatially indirect recombination involving the SIQDs (line B).

This transfer process can be enhanced by inserting the structure into a Metal-Insulator-Semiconductor device with an n<sup>+</sup> doped GaAs layer serving as a back contact and a semi transparent Schottky top surface contact. An applied voltage bias will provide the exciton storage function to the device. The read process will be induced by a positive bias that will induce the hole tunneling from the SIQDs to the InAs QDs.

The samples were mounted in a closed cycle helium cryostat and cooled to a temperature below 5 K. An Argon ion laser was used for excitation. The photoluminescence (PL) signal was collected through a 0.19 m single monochromator and detected by either a cooled photomultiplier tube or a liquid nitrogen cooled Si charge coupled device camera. For the time resolved PL experiments, an Argon ion laser was modulated at 0.2 Hz with a pulse width of about 50 ms. For shorter time resolved PL measurements, an acousto-optic modulator and a small aperture were used to create short (< 0.5 μs) Argon ion laser pulses. A multichannel scaler with a smallest time bin width of 5 ns was used to count and accumulate a time dependent histogram of the single photons.

The SIQDs photoluminescence for several optical pumping powers is labeled as B in Fig. 6. The luminescence lines shown on the PL spectra correspond to the transitions indicated on the band diagram schematic. The optically induced dipole created by the efficient separation of the electron and hole into adjacent QDs-SIQDs pairs induces a band bending that is responsible for the observed blue shift of the luminescence (Fig.6) as

the optical pumping power is increased. The highest pumping power results in a saturation of the SIQDs luminescence and eventually the thin QW luminescence process dominates.

After loading the electron hole pairs, their storage can be performed under various voltage bias conditions. For the present experiments, we chose a 0 V bias and the only built in field is that due to the Fermi level alignment between the  $n^+$  doped back GaAs electrode and the front semi transparent Schottky contact front electrode. Fig. 7 shows a typical result of a time resolved PL experiment along with the corresponding schematic band diagrams of the device. The detection wavelength was set to the peak of the QD luminescence (peak A at 1.25eV in Fig. 6) and only a small number ( $\sim 10\%$ ) of QDs are contributing to the signal. During the laser pulse we observe an intense emission from the QDs. As a bias read out pulse of 0.5 V is applied 3 seconds after the write laser pulse, we observe luminescence from the QDs indicating a successful readout of the stored charge. Without a laser excitation pulse, there is no detectable luminescence from the QDs (Fig.7b).

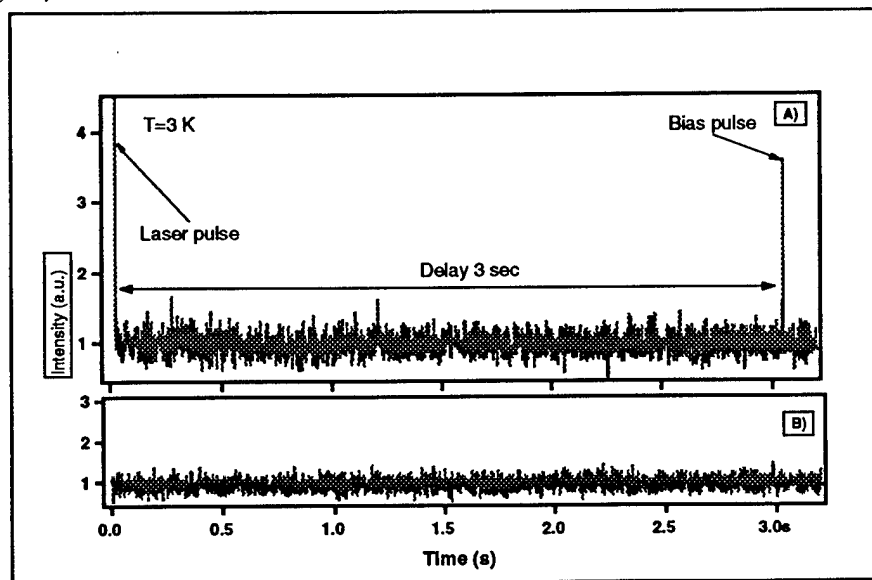

Fig. 7: Time resolved luminescence from the QDs detected at 1.25eV eV. (A) Writing the QD memory with a 2  $\mu$ J laser pulse at 3K and reading with a short 0.5V positive bias pulse. (B) No laser pulse but the same readout bias pulse.

For this device structure, the optimal read out voltage bias pulse was found to be 0.5 V with a duration of 3 $\mu$ sec. The integrated PL signal in the temperature range 10K –130K falls off with increasing temperature and from this data, the measured activation energy for the exciton loss with temperature is  $\sim 20$ meV. Analysis of the luminescence shift

with increasing temperature suggests that the temperature dependence of the band gap together with thermal evaporation of carriers out of the thinnest quantum dots in the structure are responsible for the observed red shift. From the collected signal, we obtain a rough estimate for the device efficiency of  $\sim 10^{-8}$  at  $T=10\text{K}$  and after storing the information for 100 milliseconds. This number could be improved by loading the excitons while the device is under a negative bias of  $\sim -3\text{V}$ . This will insure an efficient transfer of the electrons from the X level in the AIAs into the InAs QDs.

The time dependence of the stored luminescence at low temperature in Fig. 8 for a read out bias of  $0.5\text{V}$  shows a stored luminescence signal decay,  $I_s$ , which can be fitted to 2 exponentials. For short storage times ( $5\mu\text{sec}-800\text{msec}$ ),  $I_s \sim 4 \times 10^{-2} / \exp(0.57t)$  while for long storage time ( $800\text{msec}-3\text{sec}$ ),  $I_s \sim 3 \times 10^{-2} / \exp(0.18t)$  where  $t$  is the storage time in seconds. The stored signal decreases by  $\sim 50\%$  in 3 seconds and extrapolation to the noise level gives a storage time of nearly 10 s.

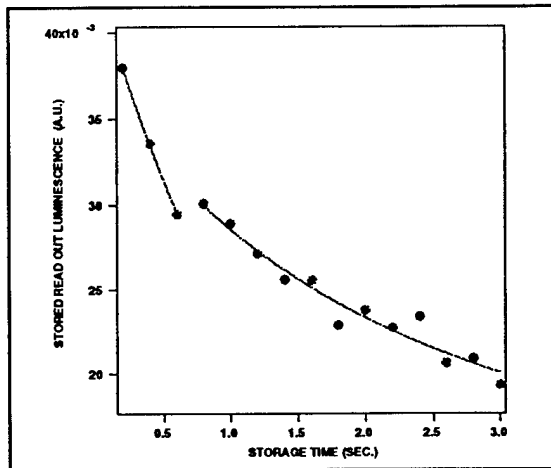

Fig. 8: Low temperature (3K) integrated intensity of the read out signal as function of time for a forward bias of  $0.5\text{V}$ . The lines are exponential fits to the data. The storage time extrapolated to the average noise level (on this scale is  $6.10^{-3}$ ) is  $\sim 10$  seconds.

The origin of these losses is still not clear but several effects could be responsible for the decreasing read out signal. First, the overlap of the electrons and holes wave functions could be significant and some of

the stored spatially indirect excitons could be lost during the storage time. Second, carriers (holes) losses could occur by capture at deep levels in the AIAs barrier by tunneling during the storage cycle. Third, since the MBE material has a Carbon acceptor background concentration of  $\sim 5.10^{15}\text{cm}^{-3}$ , it is possible that some of the electrons stored in the InAs QDs could be recombining with the residual holes.

The exciton storage times are nevertheless remarkably long:  $\sim 10^9$  times those of the excitons lifetimes in QDs ( $1-5 \times 10^{-9}\text{s}$ ). These long exciton storage times should also be compared to exciton lifetimes in n-i-p-i QW structures. Typical values of  $\sim 1\text{msec}$  at  $4\text{K}$  have been reported and in this case the structure do not exhibit a memory function. In Type I-Type II coupled QW structures which do not contain QDs, exciton lifetimes of a few microseconds have been reported. The long storage times in the present QDs

structures are consistent with electron-hole pairs localization in the QDs pairs and a low concentration of recombination centers in the QDs.

Much remains to be done to fully understand these very long exciton lifetimes and to make use of the high density of QDs as a cheap storage medium. Nevertheless writing and retrieving information using light and self assembled QDs may offer significant speed and power advantages for the next generation of devices.

#### 6) LIST OF ALL PUBLICATIONS AND REPORTS:

Warburton, R.J.; Miller, B.T.; Durr, C.S.; Bodefled, C.; Karrai, K.; Kottbaas, J.P.; Medeiros-Ribeiro, G.; Petroff, P.M.; Huant, S. **Coulomb interactions in small charge-tunable quantum dots: A simple model.** Physical Review B (Condensed Matter), vol.58, (no.24), APS through AIP, 15 Dec. 1998. p.16221-31.

Bodefled, M.C.; Warburton, R.J.; Karrai, K.; Kotthaus, J.P.; Medeiros-Ribeiro, G.; Petroff, P.M. **Storage of electrons and holes in self-assembled InAs quantum dots.** Applied Physics Letters, vol.74, (no.13), AIP, 29 March 1999.p.1839-41.

Warburton, R.J.; Miller, B.T.; Durr, C.S.; Bodefled, C.; Karrai, K.; Kottbaas, J.P.; Medeiros-Ribeiro, G.; Petroff, P.M.; Huant, S. **Coulomb interactions in small charge-tunable quantum dots: A simple model.** Physical Review B(Condensed Matter), vol.58, (no.24), APS through AIP, 15 Dec. 1998. p.16221-31.

W.Schoenfeld, T.Lundstrom and P.M.Petroff. **Charge separation in coupled InAs quantum dots and strain induced quantum dots.** Appl. Phys. Lett. 74. 15, 2194 (1999).

Ribeiro, E.; Jaggi, R.D.; Heinzl, T.; Ensslin, K.; Medeiros-Ribeiro, G.; Petroff, P.M. **Metal-insulator transition in a disordered two-dimensional electron gas in GaAs-AlGaAs at zero magnetic field.** Physical Review Letters, vol.82, (no.5), APS, 1 Feb. 1999. p.996-9.

Luyken, R.J.; Lorke, A.; Govorov, A.O.; Kotthaus, J.P.; Medeiros-Ribeiro, G.; Petroff, P.M. **The dynamics of tunneling into self-assembled InAs dots.** Appl.Phys. Lett. vol.74, (no.17), AIP, 26 1999. p.2486-8.

T.Lundstrom, W.Schoenfeld, H.Lee and P.M.Petroff " **Excitons Storage In Semiconductor Self Assembled Quantum Dots.**" Science 1999 (under press).

**LIST OF SCIENTIFIC PERSONNEL WORKING ON THE PROJECT:**

P.M.PETROFF, Principal investigator, professor

Winston Schoenfeld , graduate student, will finish is P{hD in July 2000.

Thomas Lundstrom, Postdoctoral researcher.

Hao Lee, Postdoctoral researcher.