

# REPORT DOCUMENTATION PAGE

Form Approved  
OMB No. 0704-0188

Public reporting burden for this collection of information is estimated to average 1 hour per response, including the time for reviewing instructions, searching existing data sources, gathering and maintaining the data needed, and completing and reviewing the collection of information. Send comments regarding this burden estimate or any other aspect of this collection of information, including suggestions for reducing this burden, to Washington Headquarters Services, Directorate for Information Operations and Reports, 1215 Jefferson Davis Highway, Suite 1204, Arlington, VA 22202-4302, and to the Office of Management and Budget, Paperwork Reduction Project (0704-0188), Washington, DC 20503.

1. AGENCY USE ONLY (Leave blank)		2. REPORT DATE 10 December 99	3. REPORT TYPE AND DATES COVERED Final, 27 May-26 November 99	
4. TITLE AND SUBTITLE An Automatic Self-Cleaning 5 Micron Fuel Oil Filter			5. FUNDING NUMBERS N00164-99-C-0056	
6. AUTHORS Chang-Wei Jen			8. PERFORMING ORGANIZATION REPORT NUMBER MSI TR-8040	
7. PERFORMING ORGANIZATION NAME(S) AND ADDRESS(ES) Mechanical Solutions, Inc. 1719 Route 10 East, Suite 205 Parsippany, NJ 07054			10. SPONSORING/MONITORING AGENCY REPORT NUMBER	
9. SPONSORING/MONITORING AGENCY NAME(S) AND ADDRESS(ES) Naval Surface Warfare Center, Crane Division 300 Highway 361 Crane, IN 47522-5001			11. SUPPLEMENTARY NOTES	
12a. DISTRIBUTION/AVAILABILITY STATEMENT Approved for public release; distribution unlimited.			12b. DISTRIBUTION CODE	
13. ABSTRACT (Maximum 200 words) This project demonstrated the feasibility of an innovative design that combines centrifugal separation, cross-flow filtration (CFF), Dean flow surface cleaning, and back-flush techniques into an effective micro-filtration unit. The centrifugal separation is effective in separating debris which has higher specific gravity than that of the DFM for particles as small as 20 microns. CFF makes use of the shear force parallel to the filter medium to reduce the cake formation on the filter surface, and is especially effective for feed flow with colloidal solids. Dean flow is a secondary flow created in a curved flow passage. The resulting flow profile takes the form of a toroidal vortex. The vortex profile generates a high shear rate which acts to transport material such as colloidal solids and fine debris away from the membrane surface. The combination of these features with an automatic back-flushing device forms a compact, self-cleaning, and continuously operable unit suitable for pre-filtration in Navy shipboard fuel oil systems. A bench-scale model was created which proved that all the features are feasible. The operation of Dean Flow was visually observed and documented photographically. Structural integrity of the housing was investigated with finite element analysis. Variable filter media, including ceramic and polymeric as well as metal filter membranes, were tested specifically for their suitability for fuel oil filtration applications. Parametric studies of back-flush were performed, and quantitative benefits of back-flushing were documented for the candidate filter media. All these tasks were performed to lay the foundation for the development of a prototype with a capacity of 135 gpm in Phase II.				
14. SUBJECT TERMS SBIR Report Centrifugal Separation Fuel Oil Micro-Filtration			15. NUMBER OF PAGES 53	
			16. PRICE CODE	
17. SECURITY CLASSIFICATION OF REPORT Unclassified	18. SECURITY CLASSIFICATION OF THIS PAGE	19. SECURITY CLASSIFICATION OF ABSTRACT Unclassified	20. LIMITATION OF ABSTRACT UL	

NSN 7540-01-280-5500

Computer Generated

STANDARD FORM 298 (Rev 2-89)  
Prescribed by ANSI Std Z39-18  
98-102

19991214 055

## TABLE OF CONTENTS

	Page
LIST OF FIGURES	3
LIST OF TABLES	3
LIST OF ABBREVIATIONS	4
ABSTRACT	5
1. INTRODUCTION	
1.1 Background	6
1.2 Outline of MSI's Proposed Method	7
1.3 Objectives	10
2. TEST SETUP OF THE PROPOSED DESIGN	
2.1 Bench-Top Model	11
2.2 Test Loop	12
2.3 Automatic Back-Flush	12
2.4 Filter Element Test Method	12
3. RESULTS AND DISCUSSION	
3.1 Observations of the Design Features	13
3.2 Comparison of Various Filter Media in Gravimetric Test	15
3.3 Parametric Studies of Back-Flush	18
4. CONCLUSIONS	19
5. APPENDIX A - Related CAD Drawings of Bench-Top Model	21
6. APPENDIX B - FEA Results for Housing Structure	31
7. APPENDIX C - Information of Test Loop and Test Method	38
8. APPENDIX D - Parametric Studies of Automatic Back-Flush	47

## LIST OF FIGURES

1. Dead-End Filtration with Cake Formation vs. Cross-Flow Cake-Free Filtration
2. MSI's MF Design for Fuel Oil Filtration
3. Dean Flow in the Cross Section of a Curved Pipe
4. Automatic Back-Flush
5. Air Column at Center
6. Flow Throttled Back to Show Dean Flow
7. Effect of Dean Flow on Test Cartridge used in Water Filtration
8. Effect of Dean Flow on Test Cartridge used in Diesel Fuel Filtration
- A-1 Bench-Top Model - Assembly Drawing
- A-2 Bench-Top Model - Cover
- A-3 Bench-Top Model - Upper Flange
- A-4 Bench-Top Model - Housing Tube
- A-5 Bench-Top Model - Lower Flange
- A-6 Perspective View of Bench-Top Model
- A-7 Perspective Transparent View of Bench-Top Model
- A-8 Perspective Cut-Away View of Bench-Top Model
- A-9 Membrane Cartridge for Bench-Top Model
- B-1 FEA of Bench-Top Model - Stress Contours of Bottom Plate
- B-2 FEA of Bench-Top Model - Stress Contours of Bottom Plate (different view angle)
- B-3 FEA of Bench-Top Model - Deformation Plot of Bottom Plate
- B-4 FEA of Bench-Top Model - Stress Contours of Cylindrical Housing with 1/4" wall
- B-5 FEA of Bench-Top Model - Deformation Plot of Cylindrical Housing with 1/4" wall
- B-6 FEA of Bench-Top Model - Stress Contours of Cylindrical Housing with 1/8" wall
- C-1 Bench-Top Model P&ID
- C-2 Performance Curve of Test Loop Feed Pump
- D-1 Effect of Back-Flush on Filtrate Flux (1000 PPM Contamination)
- D-2 Effect of Back-Flush on Filtrate Flux (2000 PPM Contamination)
- D-3 Effect of Back-Flush on Filtrate Flux (2000 PPM Contamination, 10 sec/5 min Back-Flush Cycles)
- D-4 Effect of Back-Flush on Filtrate Flux (1000 PPM Contamination, 10 sec/1 min Back-Flush Cycles)
- D-5 Effect of Back-Flush on Filtrate Flux (2000 PPM Contamination, 10 sec/3 min Back-Flush Cycles)
- D-6 Effect of Back-Flush on Filtrate Flux (2000 PPM Contamination, 10 sec/10 min Back-Flush Cycles)

## LIST OF TABLES

- 1 Summary of Tested Filter Media Using Tap Water as the Feed
- 2 Summary of Tested Filter Media Using Diesel Fuel as the Feed
- C-1 ISO 12103 Test Dust Particle Size Distributions List

## LIST OF ABBREVIATIONS

CAD	Computer Aided Design
CCDB	Centrifugal, Cross-Flow, Dean-Flow, and Back-Flushable
CFF	Cross-Flow Filtration
DFM	Diesel Fuel Marine
FEA	Finite Element Analysis
gpm	Gallons per Minute
hp	Horsepower
MF	Micro-Filtration
mg/L	Milligrams per Liter
NC	Normally Closed
NO	Normally Open
P&ID	Process and Instrument Diagram
PPM	Part per Million
psi	Pounds per Square Inch
RO	Reverse Osmosis
SV	Solenoid Valve
UF	Ultra-Filtration
µm	Micron

## ABSTRACT

Report developed under SBIR contract for Topic Number: N99-086. This project demonstrated the feasibility of an innovative design that combines centrifugal separation, cross-flow filtration (CFF), Dean flow surface cleaning, and back-flush techniques into an effective micro-filtration unit. The centrifugal separation is effective in separating debris which has higher specific gravity than that of the DFM for particles as small as 20 microns. CFF makes use of the shear force parallel to the filter medium to reduce the cake formation on the filter surface, and is especially effective for feed flow with colloidal solids. Dean flow is a secondary flow created in a curved flow passage. The resulting flow profile takes the form of a toroidal vortex. The vortex profile generates a high shear rate which acts to transport material such as colloidal solids and fine debris away from the membrane surface. The combination of these features with an automatic back-flushing device forms a compact, self-cleaning, and continuously operable unit suitable for pre-filtration in Navy shipboard fuel oil systems. A bench-scale model was created which proved that all the features are feasible. The operation of Dean Flow was visually observed and documented photographically. Structural integrity of the housing was investigated with finite element analysis. Variable filter media, including ceramic and polymeric as well as metal filter membranes, were tested specifically for their suitability for fuel oil filtration applications. Parametric studies of back-flush were performed, and quantitative benefits of back-flushing were documented for the candidate filter media. All these tasks were performed to lay the foundation for the development of a prototype with a capacity of 135 gpm in Phase II.

### Potential Applications and Benefits

The proposed design will offer a reliable, efficient, compact, and self-cleaning filtration system with periodic automatic back-flushing capability suitable for marine and Navy shipboard applications. It can be used as a pretreatment system for commercial Reverse Osmosis, Nano-Filtration, Ultra-Filtration, and Micro-Filtration applications. Also, fouling of membrane elements is a constant problem for commercial fuel and lube oil systems. Because the proposed design can reduce operating cost, maintenance effort, and be able to fit into any existing system, therefore it is expected to be adopted by the market.

### Keywords

SBIR Report  
Centrifugal Separation  
Fuel Oil  
Micro-Filtration

Cross-Flow Filtration  
Dean Flow  
Self Cleaning  
Back-Flush

# 1. INTRODUCTION

## 1.1 Background

In order to maintain the DFM (diesel fuel marine) quality for Navy shipboard propulsion systems, filters are essential in the fuel purification system. The current filters used for DFM prefiltration are cartridge filters, which are usually filament-wound filtration elements in a typical design. The cartridge filters usually have a very limited life and have to be replaced periodically. The replacement of the cartridge filters not only require maintenance man-hours, but also create hazardous material issues.

The cartridges filters are functional through dead-end pressure feed. The dead-end pressure feed design is prone to plugging filters easily due to cake formation as shown in Fig. 1.

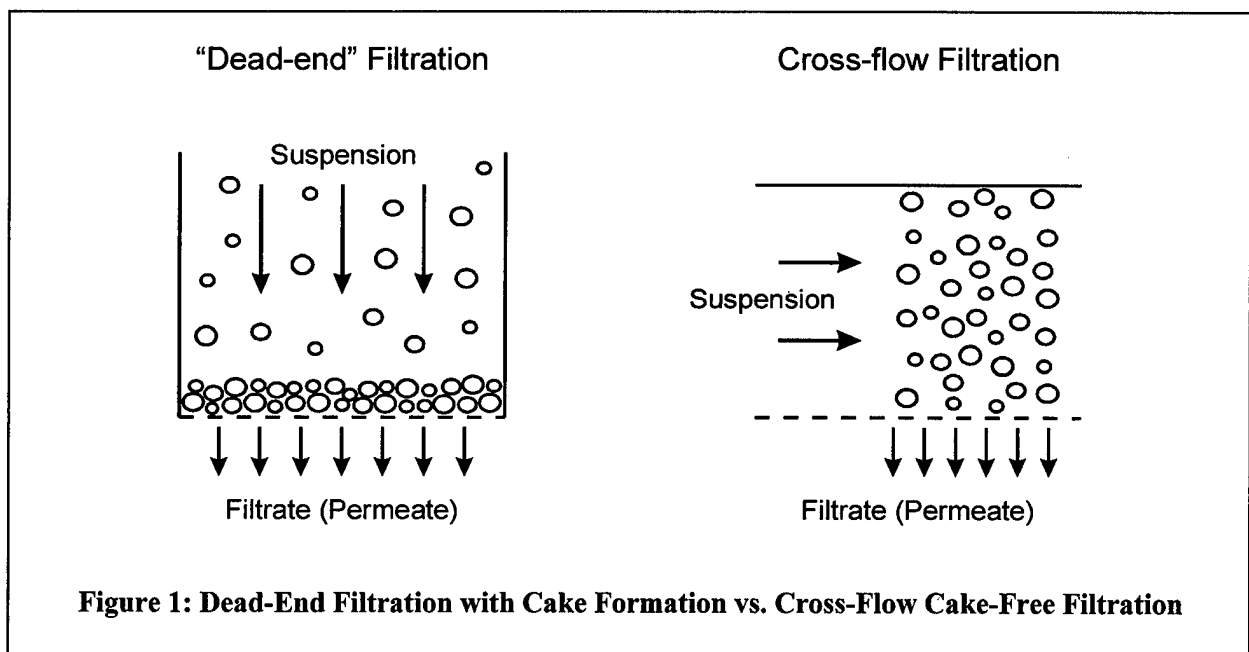

Seawater is introduced to the DFM storage system when trimming is performed to keep the ship in balance, and thus causes contamination. The contamination of the fuel with the seawater creates potential shipboard purification and operational problems. Sodium, which is a major seawater-bound impurity, is often the cause of material corrosion on the high temperature internal surfaces of an engine. In addition, a significant amount of debris that exists in the DFM is from the seawater. Among this debris, the micro-organic debris introduced by the seawater is among the toughest to handle. Micro-organisms are unlike most other debris such as carbon residue caused by pyrolysis, iron oxide, and paint chips, which can all easily be separated. The micro-organic debris from seawater are suspended solids such as colloidal solids and plankton. They are entrained to the seawater and are not likely to be separated effectively by a centrifugal fuel purifier, because their specific gravity is lighter than that of the DFM. When they are carried to the prefilter, the pressure of the dead-end filtration will cause the gelatinous colloidal solids to

extrude through the filter element's pores. Therefore, the debris will be built up rapidly on the filter surface of the dead-end filtration cartridge.

## 1.2 Outline of MSI's Proposed Method

The innovative design proposed by MSI is a compact self-cleaning filtration system with periodic automatic self-cleaning capability. It is composed of four major features, which are 1) centrifugal particulate separation, 2) cross-flow MF (Micro-Filtration), 3) Dean Flow surface cleaning, and 4) periodic automatic back-flushing, into one integral unit for application to fuel oil filtration systems. For convince, the four design features are shorten as CCDB.

The conceptual design of the system is shown in Figure 2, and the flow passage can be explained as follows:

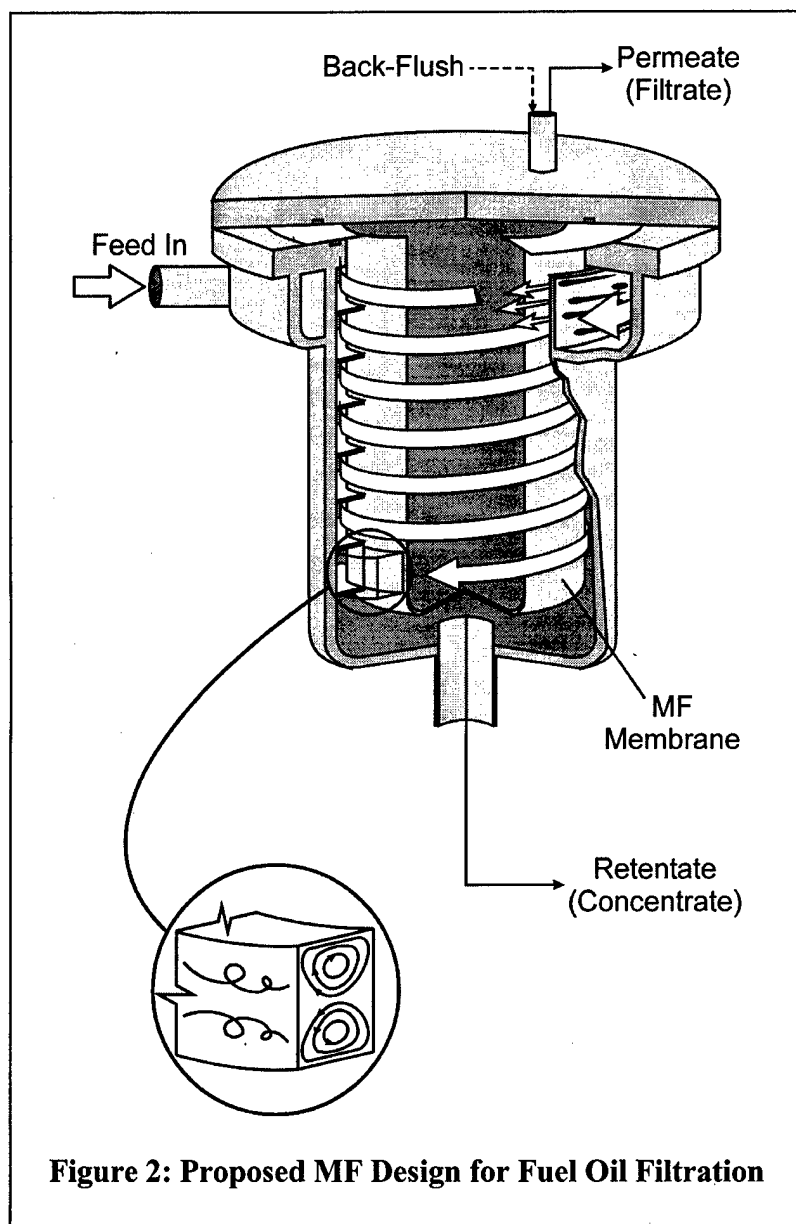

**Figure 2: Proposed MF Design for Fuel Oil Filtration**

- 1) DFM flow is fed into the donut-shaped inlet chamber tangentially, which sets up a circulating flow.
- 2) The flow passes through tangential slots which function as nozzles, and is thereby accelerated into the cylindrical chamber.
- 3) Those solids which are heavier than the liquid are thrown outward to the wall by centrifugal force and pass down along a downward spiraling guide along with the retentate (liquid that does not pass through the filter, also called concentrate).
- 4) Those particulate solids which have a higher specific gravity than that of the filtrate liquid will stay outward, while the desired liquid is forced through the filter by the applied fuel pump pressure.
- 5) The concentrate or retentate is piped to the waste storage tank or back to the transfer tank for cycling.

- 6) The liquid which passes through the MF membrane, (this liquid is called filtrate or permeate) is piped out from the top of the unit to the coalescer filters. A small part of the permeate will be used for back-flush.
- 7) The process fluid as it spirals down creates a secondary flow called Dean flow. The shear forces generated by the vortices of the Dean flow (inset of Fig. 2) create a constant cleaning motion on the membrane surface.
- 8) Periodic automatic back-flushing is performed by automatically admitting several bursts compressed air into the permeate chamber, which is centered within the cylindrical MF membrane.

### 1.2.1 Centrifugal Particulate Separation

The proposed step of centrifugal separation will be effective in accomplishing particulate filtration down to 20 microns for debris that have higher specific gravity than that of DFM based on general industrial experience. The purpose of centrifugal separation is to provide a rough screening for mechanical protection. The separation of debris of smaller size or with low specific gravity, such as iron oxide, silt, plankton, or any colloidal solids, will rely on the other features in this design. These features are cross-flow MF, Dean flow vortices, and periodic automatic back-flushing as described below.

### 1.2.2 Cross-Flow Filtration (CFF)

As opposed to dead-end filtration, cross-flow filtration (CFF) as shown in Figure 1 is a relatively new technique. Until now, it has been applied mainly to solute separation processes, such as ultra-filtration (UF) and reverse osmosis (RO). This technique is also now used for MF. The purpose of cross-flow is to prevent the formation of the cake on the surface of the filter medium. Particles deposited on the filter medium are swept away by the feed flow. The cleaning efficiency of the flowing liquid increases with its velocity. Thus, the particle and solute concentration polarization is controlled by the flow velocity.

The feed flow in this design is driven within the filter in a downward spiraling direction relative to the filter surface as shown in Figure 2. Since the flow is in parallel with the filter surface and at the same time is being pressurized against the filter surface, it forms CFF.

Flow velocity is of fundamental importance to the performance of a cross-flow filter. Should the flow velocity become zero, the cross-flow stops and the dead-end filtration (with its various drawbacks) starts. The cake which forms on the filter media at zero velocity becomes thinner when the flow velocity, parallel to the medium, increases. The thickness of the cake layer in a flow channel is determined by the shear force on the membrane surface which is roughly in direct proportion to the feed viscosity and the feed flow velocity. Therefore, higher velocity entails a thinner deposit layer, a lower hydraulic resistance, and therefore a higher filtrate flux. This explains the purpose of the slots which function as nozzles to enhance the feed flow velocity in the inlet chamber of the proposed design.

### 1.2.3 Dean Flow

A technique that will further enhance CFF is the creation of vortices generated by Dean flow on the membrane surface. The high shear force created by the circular motion of the vortices will constantly clean the membrane surface. This results in a higher flux rate and prolongs the interval before back-flushing is required.

The phenomenon of Dean flow was first conceived by W. R. Dean who studied the secondary flow created by the motion of fluid in a curved pipe. His study showed that flow in a curved channel appears unstable for small disturbances, compared with a sudden increase in the loss of head when flow passes through a straight pipe at the critical velocity (i.e. the transition between laminar and turbulent flow). No such sudden increase in the loss of head has ever been observed in a curved pipe even though flow rate is much higher than the critical rate. This phenomenon suggests that the pressure drop is much smaller in a curved pipe than in a straight pipe at the same flow rate. This unstable flow in a curved channel has been characterized as double-vortex flow, as shown in the inset of Figure 2 and Figure 3. The Dean number  $K$  is the characteristic parameter used to describe the conditions of the formation of vortices in this situation:

$$K = (v \cdot d / \nu) \cdot (d/R)^{0.5}$$

where  $v$  is the tangential velocity of the fluid,  $d$  is the diameter of the pipe,  $R$  is the radius of the pipe bend curvature, and  $\nu$  is the kinematic viscosity of the fluid. The higher the Dean number is, the stronger the vortices which are formed.

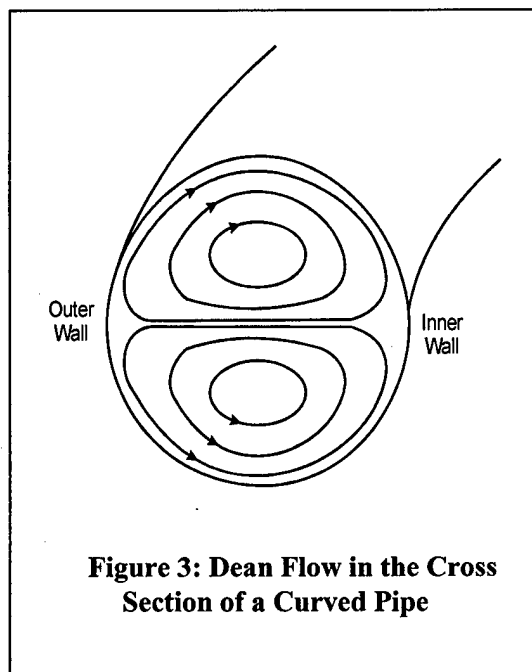

**Figure 3: Dean Flow in the Cross Section of a Curved Pipe**

The strength of the vortex action is directly proportional to the flow rate and the geometry of curved channel. Since the feed flow has the highest tangential velocity at the inlet, this means that the vortices are the strongest at the inlet end. This feature can compensate for the tendency for higher fouling at the inlet end of the CFF design mentioned in the last section. Overall, the secondary flow discussed above will not only reduce the pressure drop in the filter, but also will enhance the scrubbing shear force on membrane surfaces.

### 1.2.4 Periodic Automatic Back-Flushing

Frequently back-flushing with back pressure pulses to interrupt and penetrate the secondary membrane formed by colloidal solids is a good method to maintain a high level of flux. In the proposed design, this will be carried out by means of compressed air without interruption of the feed as shown in Figures 4A & 4B. In Fig. 4B, the compressed air is admitted into the permeate retainer to create a strong back-pressure pulse to shock off plugs. The arrangement in Fig. 4A has an extra air-operated diaphragm pump. The back pulse is created by the pump instead by air

directly. The pump will create extra kinetic energy for back pulsing as opposed to using the compressed air directly. In either the direct air or air-operated pump arrangements, the operation will be timer-controlled, occurring at preset time intervals and for a preset duration of time. The setup in Figure 4B requires an enclosed holding tank and was not investigated in Phase I study. However this will be investigated in Phase II.

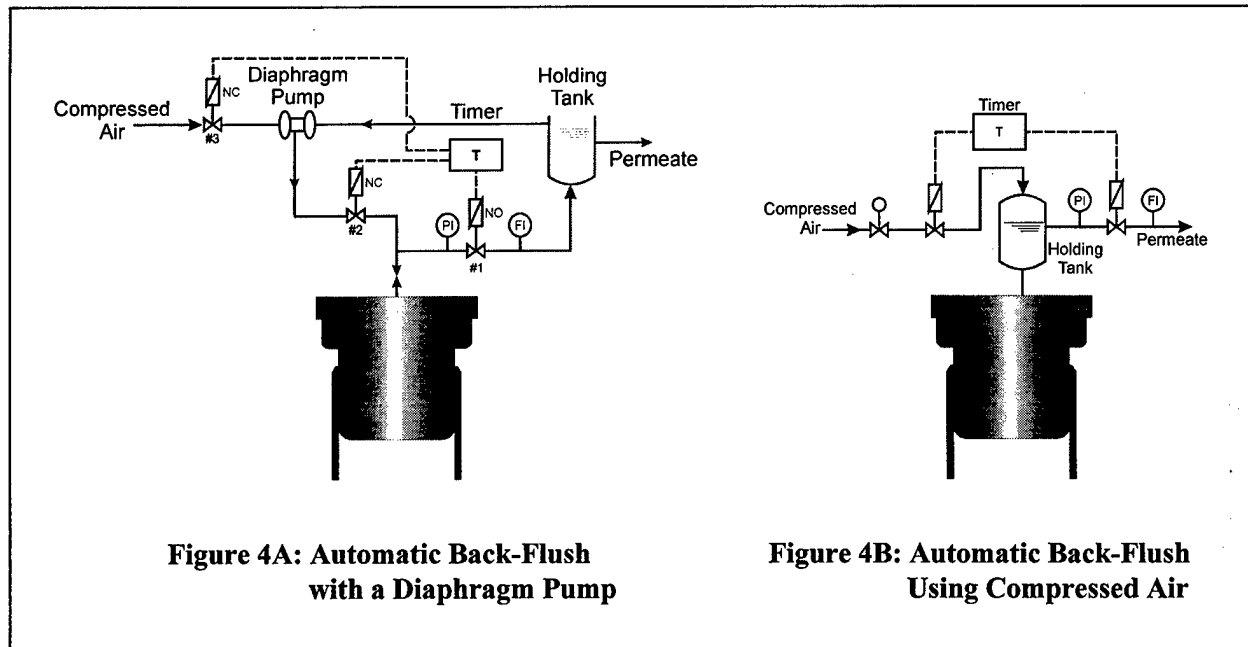

**Figure 4A: Automatic Back-Flush with a Diaphragm Pump**

**Figure 4B: Automatic Back-Flush Using Compressed Air**

### 1.3 Objectives

The objective of Phase I of this proposal was to demonstrate the feasibility of an innovative fuel filter design that combines centrifugal separation, cross-flow filtration, Dean Flow surface cleaning, and back-flush techniques into an integrated unit. Phase I demonstrated that such a unit would be compact, self-cleaning, and suitable for continuous operation, with no moving parts, and with minimal requirement for maintenance or replacement parts.

The primary objective set for Phase I was to construct and evaluate a workable bench-scale model to demonstrate the feasibility of this innovative design. The secondary goal was to lay the foundation for the development of a 135 gpm prototype in Phase II. Specific objectives of this project included:

1. Demonstrate that a particulate separator of the type described can be designed to effectively separate particles bigger than 20 microns with specific gravity greater than fuel oil.
2. Demonstrate that the designed MF filter, including increased surface flow velocity and scrubbing vortex enhancements, can work with the particulate separator and perform micro-filtration effectively in the integrated system.
3. Demonstrate that the back-flush device can work effectively to maintain high flux rate over time without significantly interfering with normal operation in the integrated filtration system.

4. Demonstrate the general superiority of the innovative filtration system as opposed to the conventional existing systems, due to the new system's superior flux rate, and the system's long times between periods required for service or cleaning.
5. Test various types of filter media, such as metal, ceramic, and polymeric filters for fuel oil application.
6. Test the automatic back-flush system, and establish preliminary cleaning and operating protocols.

## **2. TEST SETUP OF THE PROPOSED DESIGN**

### **2.1 Bench-Top Model**

A bench-top model was created along with a simple hydraulic test loop to address the above stated objectives. The housing of the bench-top model was designed to accommodate a filter cartridge with a dimension of 3" in diameter and 6" in length. The membrane area of the filter cartridge was about 0.3 ft<sup>2</sup>. To facilitate observation for testing and demonstration, the bench-top model was fabricated using Acrylic, which is a transparent thermoplastic material. Also, FEA (finite element analysis) was performed on the housing to ensure structural integrity under operating conditions (60 psi and less). The design working pressure of the housing (i.e. its capability as a pressure vessel) was 100 psi. The CAD (Computer Aided Design) drawings of the bench-top model are shown in Figures A-1 to A-8 of Appendix A, and the dimensions of a typical membrane cartridge used in the testing is shown in Figure A-9. The finite element analysis results are shown in Figures B-1 to B-6 of Appendix B.

The housing is composed of four discrete components: cover, upper flange, housing tube, and lower flange. The housing tube will be made from a 4" outside diameter tube with variable wall thicknesses. Changing the wall thickness will change the width of the flow passage between the filter cartridge and the wall. The flow passage width is a parameter that will affect the Dean Flow in the test, therefore it is useful to make the tube wall thickness variable. Since the idea is to make the tube changeable, the components can not be welded together. They are assembled using bolts.

The filter cartridge is situated between the cover and the top flange. The O-rings on the top and bottom of the cartridge flange will be clamped when the cover is bolted down to the top flange. The housing tube is situated between the top and bottom flanges. Four bolts are used to hold down the tube-flange assembly under operating pressure with an O-ring built in at both the top and bottom flanges to seal the tube. When the tube thickness is changed, the four bolts have to be taken off, but the six bolts for the cover do not have to be removed. When the filter cartridge is replaced, however, the six bolts for the cover have to be taken off, while the four bolts for the tube-flange assembly remain fastened.

## 2.2 Test Loop

The test loop consisted of the designed bench-top model, a 1¼ hp explosion-proof feed pump, a 15 gallon tank, and the designed automatic back-flush unit. The capacity of the test loop was able to handle flow rates of up to 15 gpm. The test loop plot shown as a P&ID (Process and Instrument Diagram) in Figure C-1 is attached in Appendix C. The characteristic performance curve of the feed pump is shown in Figure C-2.

## 2.3 Automatic Back-Flush

The back-flush arrangement is shown in Figure C-1. The back-flush system is composed of one diaphragm pump, and 3 two-way Solenoid Valves (SV's) controlled by two programmable timers installed in an electrical enclosure. Timer #1 controls SV #1 which is NO (Normally Open), and Timer #2 controls SV's #2 & #3 which are NC (Normally Closed). At the beginning of each cycle, Timer #1 is on and Timer #2 is off. When Timer #1 reaches the preset time it closes SV #1, and at the same time actuates Timer #2. As soon as Timer #2 is actuated, SV #2 & #3 are open and the back-flush gets started at the preset time. When the preset time is reached, Timer #2 resets Timer #1. When Timer #1 gets reset it shuts Timer #2 off and starts a new cycle. The preset time of each timer is individually controlled, which makes the adjustment of back-flush frequency and duration very flexible. The control logic has been tested satisfactorily.

## 2.4 Filter Element Test Method

For safety and economic reasons, tap water was used in the initial test, and Diesel fuel from a local gas station was used in the last test in Phase I. In the filter element test, viscosity is an important factor that affects the filtration flux rate. However it does not have any direct effect, as far as the filter element efficiency is concerned. The filter element efficiency is determined by the pore size and the structure of the filter media. Since the objective of this project is to prove the feasibility of the design concept, the primary concern should be the filter element efficiency and its continuously self-cleaning capability. Therefore using water as process fluid in the early stage of the test can be justified.

The gravimetric test of D 5452 - 98 (attached in Appendix C) with the title "Standard Test Method for Particulate Contamination in Aviation Fuels by Laboratory" was used as the test method. The reasons are a) this method is adopted by MIL-DTL-5624T mentioned above, b) the standard is relatively new compared to others, e.g. the AC test dust mentioned in MIL-F-8815 D is out of date, c) the test equipment for the gravimetric method is relatively easy to attain.

The principle of the test is to check the filter media's ability to remove the particle contents in the filtrate, which can then be measured in terms of PPM. This is done by passing one gallon of filtrate (permeate) through the ASTM specified test membranes under 30 psi feed pressure. After the filtration, the tested membranes are dried and the extra weight retained on the membrane surface is determined by calculating the difference of the test membrane weight before and after the filtration. In order not to count the weight of dissolved elements in the tested fluid, two test membrane filters with matched weight were stacked together for filtration during the test.

After being dried, the first membrane has the weight of contaminants (undissolved particles) and dissolved mineral elements, and the second membrane has the weight of dissolved mineral elements. By subtracting the weight of the second membrane from the first membrane, the weight of contaminants can be determined. The required test membrane filters (47 mm diameter, with the pore size of 0.8  $\mu\text{m}$  as specified in the ASTM spec) were acquired from Millipore.

To simulate the contaminants, Arizona test dust (ISO 12103-A4) will be used. The test dust will be mixed into the water to form various concentration for testing purposes. The test dust particle size distribution is shown in Table C-1.

To qualify as a potential filter element for production, the permeate (filtrate) that passes the element should have a contaminant removal rate of 10 mg/L (PPM) or better.

### 3. RESULTS AND DISCUSSION

#### 3.1 Observation of the Design Features

The four design features of the proposed filtration system, known as CCDB, were all proven by the testing to be attainable. The investigation of each feature will be described in the following paragraphs:

##### 3.1.1 Centrifugal Particulate Separation

The test showed that the feed stream had been accelerated successfully through the inlet nozzle. Figure 5 shows that the flow was rotating at a high speed. The figure can not show directly that the flow is rotating, however, the air column formed at the center of the cylinder can be seen. Since the fluid is heavier than the trapped air inside the cylinder, the fluid is pushed to the outside by centrifugal force and the air remains at the center.

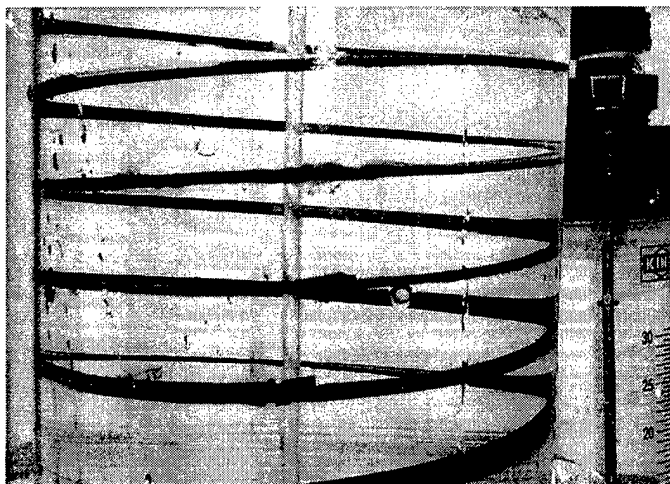

Figure 5: Air Column at Center

##### 3.1.2 Cross-Flow Filtration

The power of CFF can be observed by control the retentate (concentrate) valve. By closing the retentate valve totally, a dead end filtration can be created. Under dead-end filtration, the filter cartridge (Pall 3  $\mu\text{m}$  Nylon) can be totally plugged in less than 5 minutes using a 1000 PPM test dust in the tap water as the feed and a feed pressure of 60 psi.

A similar test was done under CFF with the same feed, feed pressure set at 54 psi, feed rate at 15 gpm, and retentate pressure of 12 psi. In this case, the filtrate dropped greatly initially from 3 gpm to 0.2 gpm in 5 minutes, then gradually stabilized after 5 minutes. Without doing back-flushing, the filtrate flow was maintained at around 0.2 gpm even after 30 minutes of filtration.

### 3.1.3 Dean Flow

Dean flow was also observed during the testing. The circular motion generated by the vortices could not be observed without some kind of help from an outside medium. Successful observation was achieved through the injection of a small amount of air into the feed flow. Since air is very light, it is carried by the flow through its movement. The motion is especially obvious when the flow is throttled down. When the flow is throttled down to a critical speed, it can be observed that the flow is twisting within the spiral flow guide (Figure 6). Because the Dean Flow (vortex action) strength is directly proportional to the flow rate, the air bubbles move to the center of the flow stream when flow speed is increased (open the throttle). The higher the speed is, the narrower the air bubble stream is, allowing relative assessment of the flow velocity. This situation is similar to the method of observation of the air column shown in Figure X, in that case the air column being caused by the high spinning speed.

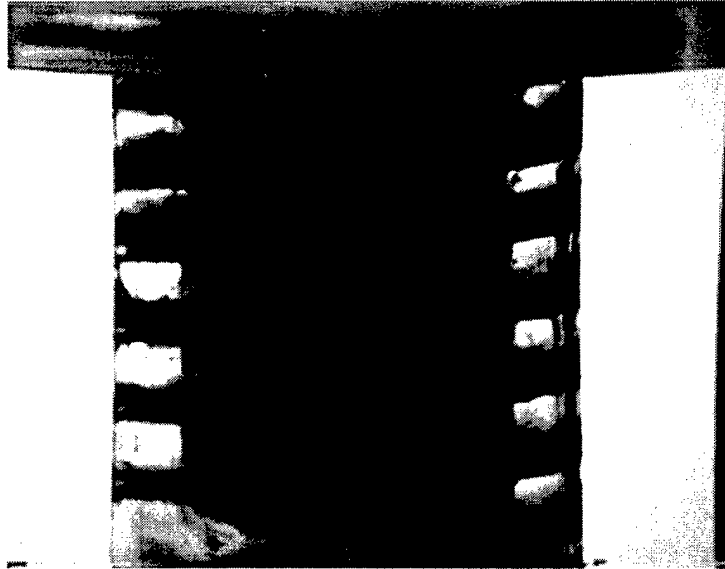

Figure 6: Flow Throttled Back to Show Dean Flow

Figure 7 clearly reveals the advantage of the Dean Flow. It shows a cartridge tested in tap water with 0.1% of test dust. The upper 1/3 of the cartridge was located in the housing without spiral guides to promote the Dean Flow and the lower 2/3 of the cartridge was located in the housing with spiral guides. The lower part has no visible cake formation due to the vortices generated by the Dean Flow which kept the surface clean.

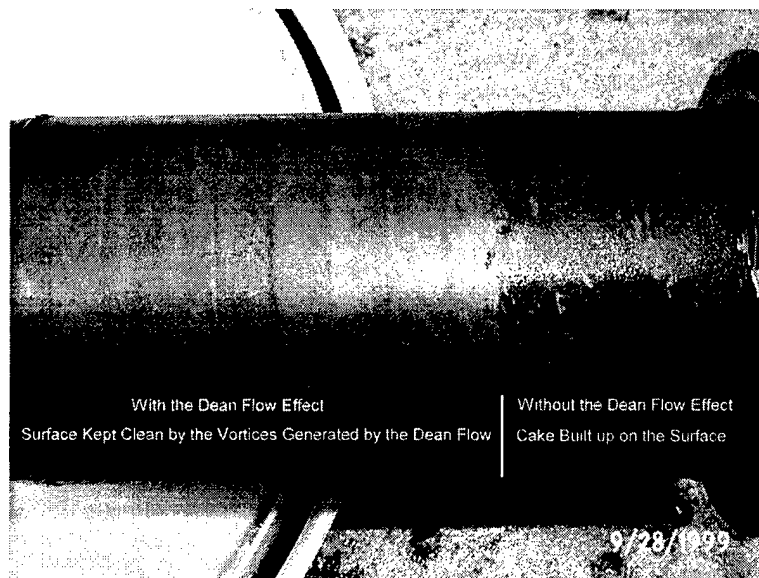

Figure 7: Effect of Dean Flow on Test Cartridge Used in Water Filtration

Figure 8 shows a cartridge tested in Diesel fuel with 0.1% of test dust. The boundary between surface with the Dean Flow effect and without the Dean Flow effect was even more obvious. This is because the Diesel fuel has higher viscosity than tap water, it makes cross-flow surface cleaning more difficult. It takes flow with high shear force such as the vortices generated by the Dean Flow to do the surface cleaning effectively. Also the test dust looks darker in the Diesel fuel than in the water, making surface contrast in the two areas more distinct.

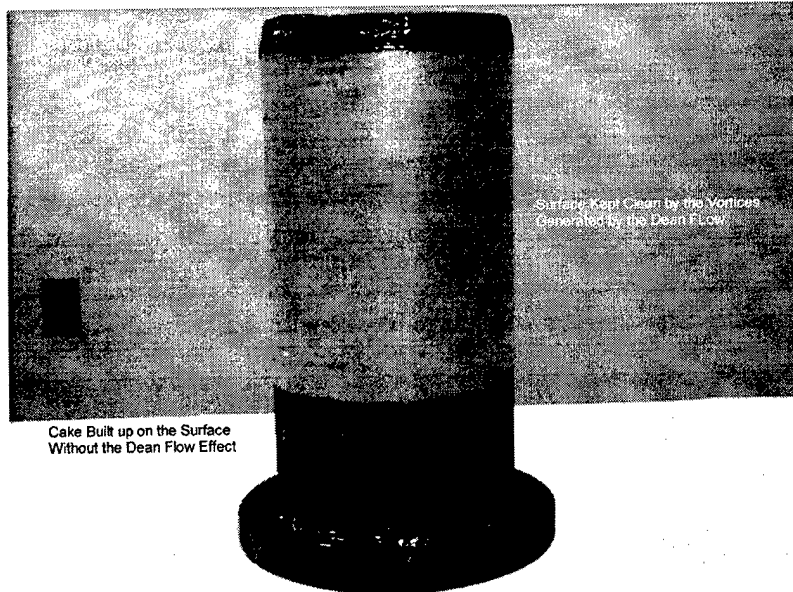

Figure 8: Effect of Dean Flow on Test Cartridge used in Diesel Fuel Filtration

### 3.2 Comparison of Various Filter Media in Gravimetric Test

#### 3.2.1 Test Using Tap Water as the Feed

Various media of different materials and pore sizes were tested. The purpose was to identify the filter medium that was most likely to meet the Navy's fuel oil filtration requirement. The characteristics of the tested filter media is listed in Table 1:

Test No.	Manufacturer, Model	Filter Media Type	Pore Size ( $\mu\text{m}$ )	Dust Concentration in Feed (PPM)	Dust Concentration in Filtrate (PPM)
1	Bekaert, Bekipor 3AL3	SS 316L, Sintered Fiber	3	10,000	1.6
2	Pall, Biodyne	Nylon 66	3	3000	5.8
3	Ferro, FAO-5	Ceramic (Alumina)	5	1000	12.1
4	Bekaert, Bekipor 3AL3	SS 316L, Sintered Fiber	3	1000	1.5
5	Mott	SS 316L, Sintered Powder	0.2	1000	6.0
6	Bekaert, Bekipor 5AL3	SS 316L, Sintered Fiber	5	1000	37.6

Table 1: Summary of Tested Filter Media Using Tap Water as the Feed

The performance of three different types of filter media were tested. They may be described as follows:

#### 1. Porous Metal Filter Media

As shown in Table 1, both the Bekaert and Mott filter are considered to be a sintered porous metal filter, but the structure of the filters is different. A sintering process is performed by maintaining compacted metal powder, fiber, or mesh at a temperature near the material's melting

point (approximately 90%, in terms of absolute temperature) for a set period of time. Counter diffusion of metal atoms occurs at the micro-structural level of the metal at contact points, and crystal formation takes place between the metals (powders, fibers, or mesh layers) to form a completely integrated metal structure. This gives a very strong bond between the metal subcomponents. The Mott membrane was made with sintered powder, and the Bekaert was made with non-woven fibers sintered together.

The filter cartridge with 3 $\mu$ m Bekaert filter media has tested several time in Phase I with dust concentration ranging from 1,000 to 10,000 PPM, the test result were very good and consistent. The measured dust concentration in the filtrate was always below 2 PPM. The initial filtrate flux rate of the test with 1,000 PPM test dust concentration in the feed was 13.7 gpm/ft<sup>2</sup>, this is 30 % higher than the initial filtrate flux rate of the test with 10,000 PPM test dust concentration in the feed which was 10.6 gpm/ft<sup>2</sup>.

With the same 0.1% test dust concentration in the feed, the filtrate quality generated by the 0.2  $\mu$ m Mott filter was not as good as that generated by the 3  $\mu$ m Bekaert filter, and the flux rate of the Mott (the initial filtrate flux rate was only 5.3 gpm/ft<sup>2</sup> which is less than 50% of the 3 $\mu$ m Bekaert filter) was inferior to Beakeart. The pore size rating of the 0.2  $\mu$ m Mott filter was based on the 50% efficiency (this by itself is not necessarily bad). The test results revealed that the pore size distribution range or the filter media was very wide, and the pore density was low. Using the pore size rating to judge the permeate quality may be deceiving.

A 5  $\mu$ m Bekaert filter cartridge was also created for a similar test. The measured dust concentration in the filtrate was 37.6 PPM, and the initial filtrate flux rate was 15.9 gpm/ft<sup>2</sup>. The filtrate quality was not good enough to be considered for a fuel oil filtration application. In addition, the initial flux rate was only 16% better than the 3  $\mu$ m Bekaert filter cartridge.

## 2. Ceramic Membranes

As an alternative material, ceramic membranes were used for bench-top testing. Both Aluminum Oxide and Silicon Carbide based ceramic materials can have very good mechanical properties. Also the pore sizes can be accurately controlled. The pore size distribution range is comparable to a polymeric membrane, which typically has a very narrow range for a given pore size.

The permeate quality of the tested ceramic filter cartridge, 5  $\mu$ m Ferro, was not up to the minimum requirement of 10 PPM. Because the requirement of the physical size and membrane pore size of the ceramic samples, it was relatively hard to get an appropriate sample. The test may not be representative. It is worth to try other ceramic cartridges with smaller pore size in Phase II.

## 3. Polymeric Membranes

Polymeric membranes are relatively inexpensive compared to other types of membranes. In addition, most polymeric membranes have consistent pore shape and have a pore size distribution in a very narrow range. The only disadvantage is that polymeric membranes need adequate

support under pressure. Therefore, particularly for the process of back-flushing, supports need to be created for both sides of the membrane. Based on MSI's previous experience in polymeric membranes, the Pall Nylon 66 (Biodyne) membrane has a good mechanical properties that can be designed with a proper support to survive back-flush in a prolonged period of time.

Although the 3  $\mu\text{m}$  Nylon membrane was qualified as a potential candidate, the 3  $\mu\text{m}$  Bekaert porous metal filter cartridge has a better debris remove capability than the 3  $\mu\text{m}$  Nylon membrane filter cartridge based on the test results shown in Table 1. Also from the point of view of back-flushing, the porous metal filter cartridge will be easier to fabricate than the polymeric cartridge. The polymeric cartridge requires an extra support on the filter surface for back-flushing, while the porous metal cartridge can be self-supportive. The cost-effectiveness based on material cost, fabrication cost, and service life shall all be taken into account. This will be determined in Phase II when more extensive test data in the potential candidates are available.

### 3.2.2 Test Using Diesel Fuel as the Feed

Totally, three different types of filter cartridges were tested, and their information is listed in Table 2.

Test No.	Manufacturer, Model	Filter Media Type	Pore Size ( $\mu\text{m}$ )	Dust Concentration in Feed (PPM)	Dust Concentration in Filtrate (PPM)
1	Bekaert, Bekipor 3AL3	SS 316L, Sintered Fiber	3	1000	Negligible
2	Osmonics, Desal JY	PVDF	0.5	1000	Negligible
3	Filtros	Ceramic (Alumina)	5	1000	24

Table 2: Summary of Tested Filter Media Using Diesel Fuel as the Feed

Although the same gravimetric test procedures (ASTM D5452-98) were followed in the test using Diesel fuel as the previous tests done by tap water, it took much longer time to get the test results as shown in Table 2. The test filters (47 mm diameter coupon) used in the tap water test can be dried in the oven (set at 80  $^{\circ}\text{C}$ ) in about 30 minutes. The test filters used in the Diesel fuel test were not fully dry after being left in the oven (set at 80  $^{\circ}\text{C}$ ) for two full days. The reason is because Diesel is difficult to fully evaporate. According to specifications for Diesel fuels (such as ASTM D975 and MIL-F-16884G) ASTM grade 1-D Diesel is only 90% evaporated at a distillation temperature of 550  $^{\circ}\text{F}$ .

The Bekaert cartridge which was tested several times previously with tap water had a consistent test result. The permeate quality was acceptable and the initial flux rate was 6.3  $\text{gpm}/\text{ft}^2$  using Diesel fuel as the feed. The flux rate of the previous test was about 13.7  $\text{gpm}/\text{ft}^2$  with tap water as the feed. The flux rate should be in reverse proportion to the feed viscosity. For a typical ASTM Grade 1-D Diesel, the kinematic viscosity is between 1.4 to 2.5 centistokes at 100  $^{\circ}\text{F}$ . The kinematic viscosity for water at the same temperature is 0.69 centistokes. Based on the viscosity information, the flux rate of 6.3  $\text{gpm}/\text{ft}^2$  in the Diesel fuel is in the right range. Since the contamination concentration is not likely as high as 1000 PPM in the real application, it is

safe to use 6 gpm/ft<sup>2</sup> as the minimum criteria for initial flux rate in the selection of filter media in Phase II.

The permeate quality of the Osmonic Desal cartridge was good. However the flux rate was low. The flux rate was only 1/10 of the flux rate of the Bekaert cartridge in the Diesel fuel test. The Filtros ceramic cartridge was not acceptable based on the permeate quality. The flux rate was not as good as Bekaert either. The flux rate was roughly 1/2 of the flux rate of the Bekaert cartridge.

### 3.3 Parametric Studies of Back-Flush

The 3 μm Bekaert metal filter cartridge which is a good candidate for the use in the prototype was chosen for the parametric studies of back-flush. The back-flush arrangement is explained in Sec. 2.3, and the schematic drawing is shown in Figure C-1.

#### 3.3.1 Use concentration rate of contamination as the parameter

Using the concentration rate of contamination as the parameter in the back-flush study, the first test had a feed with 0.1% of coarse grade Arizona test dust. Because of the high concentration of contamination, the back-flush frequency was set at 1 minute with a duration of 10 seconds. Figure D-1 shows the flux fluctuation of each cycle under 26 psi trans-membrane pressure; the average flux is around 5.4 gpm/ft<sup>2</sup>. Note that the back-flush pressure is 10 psi higher than the feed pressure with a back-flow rate of less than 2 gpm.

The second test had the concentration rate of contamination increased to 0.2%, i.e. doubled the concentration rate of contamination in the first test. Figure D-2 shows the flux fluctuation of each cycle under the same trans-membrane pressure; the average flux is around 4.7 gpm/ft<sup>2</sup>. This confirmed that the concentration rate of contamination has a crucial effect on the flux rate.

An extension of the second test was done by changing the back-flush cycles to five minutes instead of 1 minute, the back-flush duration was still kept at 10 seconds. The test still had the same feed and same flow condition. Figure D-3 shows the flux fluctuation of each cycle under the same trans-membrane pressure; the average flux is around 4.3 gpm/ft<sup>2</sup>, which was reduced to less than 10%.

#### 3.3.2 Use the rate of back-flush cycle as the parameter

With the back-flush frequency used as the test parameter, the concentration of 0.1% of Arizona test dust was used in the feed for the test. The first test had the back-flush frequency set at 1 minute with a duration of 10 seconds. Figure D-4 shows the flux fluctuation of each cycle under 23 psi trans-membrane pressure, the average flux was around 7.2 gpm/ft<sup>2</sup>. Note that the back-flush pressure is 10 psi higher than the feed pressure with a back-flow rate of less than 2 gpm. The cartridge used for this test was brand new.

In Figure D-4, it can be noticed that the initial flux rate was very high, about 50% higher than the stabilized flux rate immediately after back-flush at each cycle. This is a characteristic of cross-flow filtration. The flux rate had a great drop initially, then a secondary membrane (dynamic membrane) formed consisting of a thin layer of cake. The cross-flow dynamics will control the growth of the thin layer, and keep the flux rate stabilized. This is opposed to dead end filtration, in which the thickness of the layer will get thicker and thicker until the membrane pores get plugged totally.

It can also be noticed that the contamination rate and back-flush cycle rate were the same between the tests shown in Figures D-1 and D-4, but the stabilized flux rate was different. Other than caused by the 3 psi difference in trans-membrane pressure, the major difference was that the filter cartridge used in Figure D-4 was a brand new one and the cartridge used in Figure D-1 has been used in a prolonged period in several tests. Despite the flux rate was about 25% difference between the two tests, the flux variation range was about the same. The variation range was 4 gpm/ft<sup>2</sup> before and after back-flush. Since the major purpose of the parametric studies was to investigate the effect (relative difference) of flux rate within a chosen parameter, the test should be valid as long as the same cartridge was used in the chosen parameter and the test was progressed from less challenge condition to more challenge condition

Figure D-5 shows the same test with the back-flush cycle extended to 3 minutes instead of 1 minute, the duration of the back-flush was still 10 seconds. The test showed that although the maximum flux rate could not be recovered to the same level as the 1 minute cycle, the maximum and minimum flux can still be stabilized over time. The average flux was around 6 gpm/ft<sup>2</sup>. Although the flux rate was reduced as expected, the most important feature of the back-flush, which is that the flux rate can be recovered to a certain level on a continuous basis, was still maintained. The test showed that with a 3-minute back-flush cycle, the cartridge can stay in service for a prolonged period of time without maintenance.

Figure D-6 shows the same test with the back-flush cycle further extended to 10 minutes instead of 3 minutes, while the duration of the back-flush was still 10 seconds. The test showed that the maximum flux rate (after back-flush) and minimum flux rate (before back-flush) were deteriorating constantly. Although the deterioration rate was not linear, it seemed that it would eventually reach a stabilized level. The test was not carried on until the flux rate became stabilized because it would take a very long time to achieve this, and temperature control would be a problem in a closed test loop. The test results only serve as a reference for the future application. The actual fuel filtration application may not have such a high level (1000 PPM) of contamination, and therefore the back-flush cycle can still go up to or beyond 10 minutes in such a case. This remains to be established in Phase II efforts on an actual fuel sample.

#### 4. CONCLUSIONS

Based on the studies undertaken, the following conclusions were drawn:

- 1) The CCDB design features are all feasible in water as well as in fuel oil.

- 2) The porous metal filter cartridge made of sintered metal fiber of 3 $\mu$ m Bekaert is the best candidate for fuel oil filtration in terms of filtrate quality and flux rate.
- 3) The Nylon 66 polymeric membrane with proper support can be a good candidate for the application of fuel oil filtration.
- 4) An initial flux rate of 6 gpm/ft<sup>2</sup> is achievable in ASTM Grade 1-D Diesel fuel under room temperature and can be used as the minimum criteria in the selection of proper filter media in Phase II.
- 5) The proposed back-flush arrangement is very effective. A back-flush duration of 10 seconds is enough to penetrate most of the plugged membrane pores. The frequency from 1 minute to 10 minutes per back-flush cycle will give a constant flux rate for a prolonged period of time based on 3 $\mu$ m Bekaert membrane. The best frequency shall be determined by the contamination rate of the real sample.
- 6) The Phase I project met all of its goals and expectations. The new fuel oil concept has been proven to be feasible and effective. Funding for a vigorous Phase II project appears to be justified.

**APPENDIX A**

**Related CAD Drawings of Bench-Top Model**

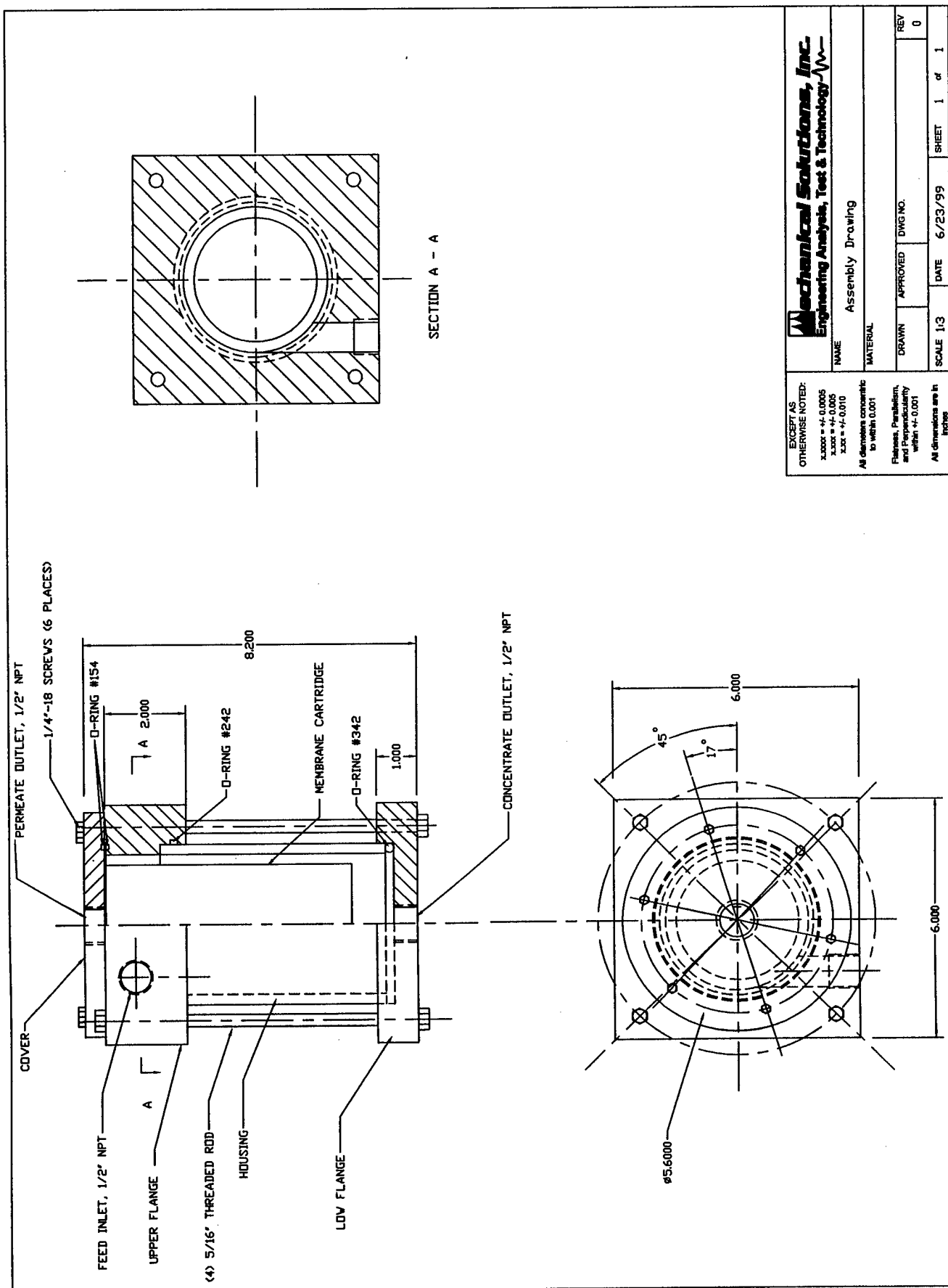

EXCEPT AS OTHERWISE NOTED:  
 x.xxx = ± 0.0005  
 x.xx = ± 0.005  
 x.x = ± 0.010  
 All dimensions concentric to within 0.001  
 Finish, Parallelism, and Perpendicularity within ± 0.001  
 All dimensions are in inches

**Mechanical Solutions, Inc.**  
 Engineering Analysis, Test & Technology

NAME: Assembly Drawing  
 MATERIAL:

DRAWN	APPROVED	DWG NO.	REV
SCALE 1:3	DATE 6/23/99	SHEET 1 of 1	0

Figure A-1

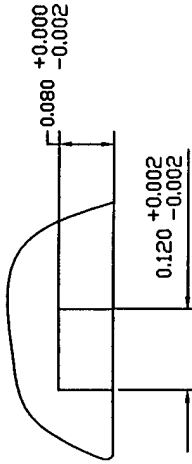
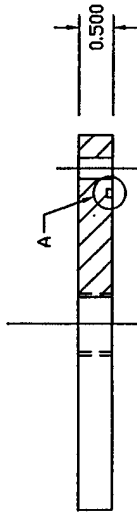

SECTION A  
10:1

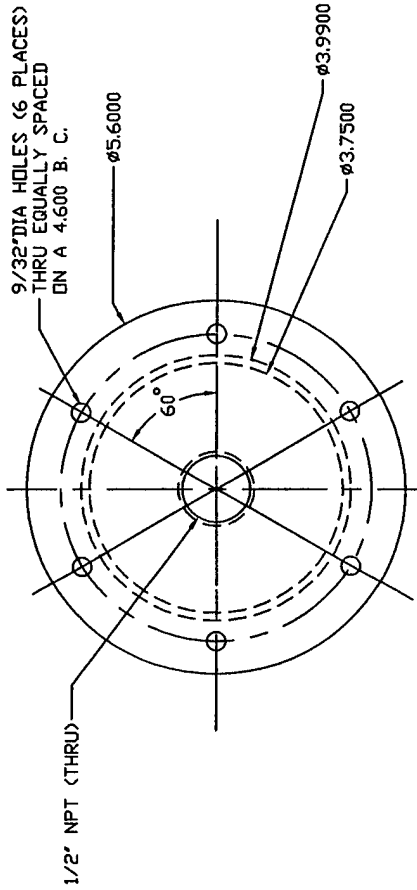

<b>Mechanical Solutions, Inc.</b> Engineering Analysts, Test & Technology			
NAME	Cover		
MATERIAL			
DRAWN	APPROVED	DWG NO.	REV
SCALE 1:2.5	DATE 6/23/99	SHEET 1 of 1	0

EXCEPT AS OTHERWISE NOTED:  
 X.XXX = ±0.0005  
 X.XX = ±0.0005  
 X.X = ±0.0010  
 All diameters concentric to within 0.001  
 Flatness, Parallelism, and Perpendicularity within ±0.001  
 All dimensions are in inches

Figure A-2

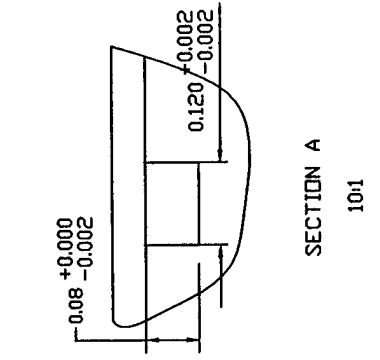

SECTION A  
10:1

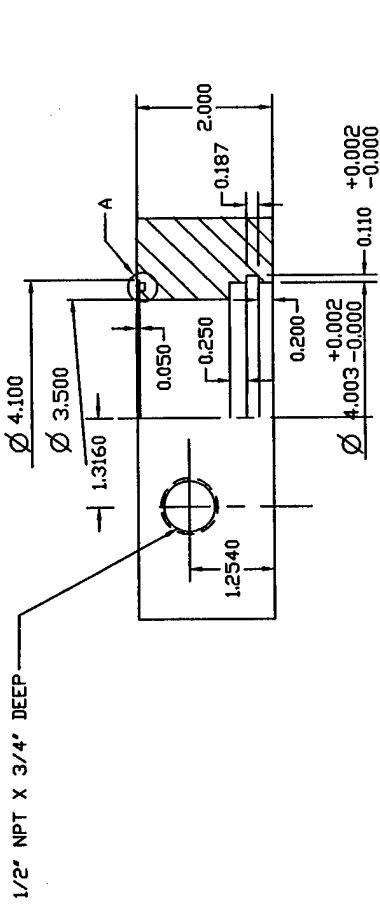

1/2" NPT X 3/4" DEEP

11/32" DIA. HOLES THRU EQUALLY SPACED ON A 6.800 B. C.

1/4" -20 TAP (6 PLACES) 3/8" DP. EQUALLY SPACED ON A 4.700 B.C.

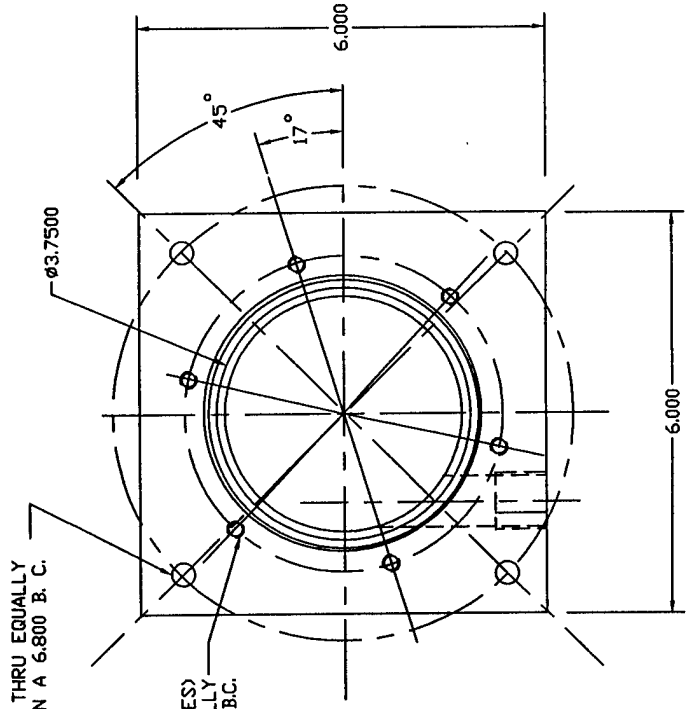

<b>Mechanical Solutions, Inc.</b> Engineering Analysts, Test & Technology	
NAME	Upper Flange
MATERIAL	
DRAWN	APPROVED
DWG NO.	REV
DATE	6/23/99
SHEET	1 of 1

EXCEPT AS OTHERWISE NOTED:  
 X.XXXX = +/- 0.0005  
 X.XXX = +/- 0.005  
 X.XX = +/- 0.010  
 All diameters concentric to within 0.001  
 Flatness, Parallelism, and Perpendicularity within +/- 0.001  
 All dimensions are in inches

Figure A-3

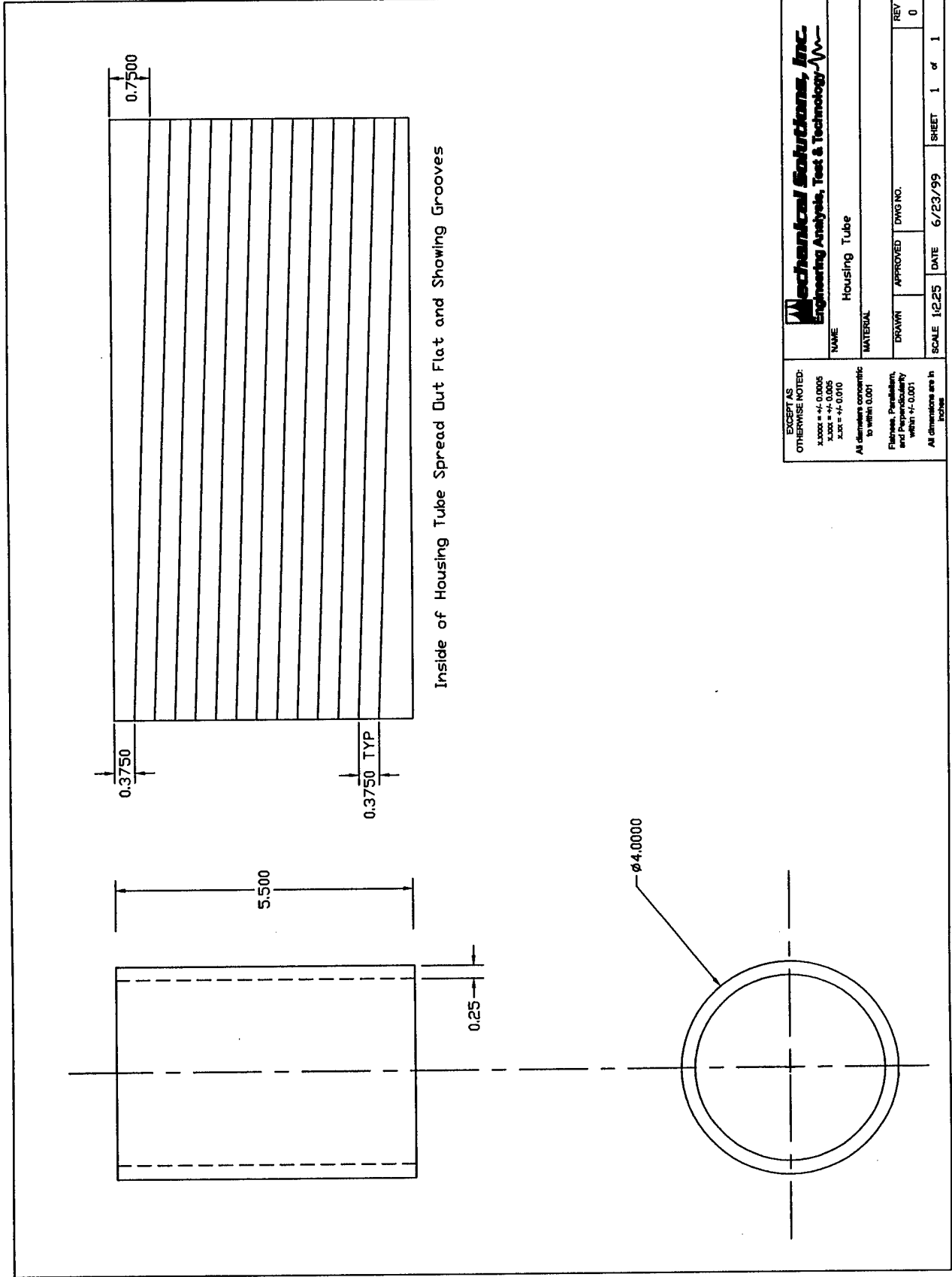

<b>Mechanical Solutions, Inc.</b> Engineering Analysis, Test & Technology		NAME Housing Tube MATERIAL	
EXCEPT AS OTHERWISE NOTED: X.0002 = +/- 0.0005 X.000 = +/- 0.005 X.XX = +/- 0.010 All dimensions concentric to within 0.001 Flatness, Parallelism, and Perpendicularity within +/- 0.001 All dimensions are in inches	DRAWN APPROVED	DWG NO. DATE	REV 0
SCALE 1:2.25		DATE 6/23/99	SHEET 1 of 1

Figure A-4

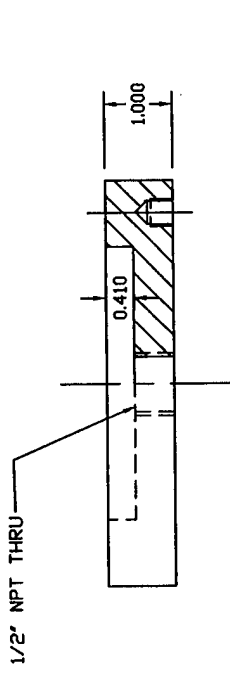

SECTION A-A

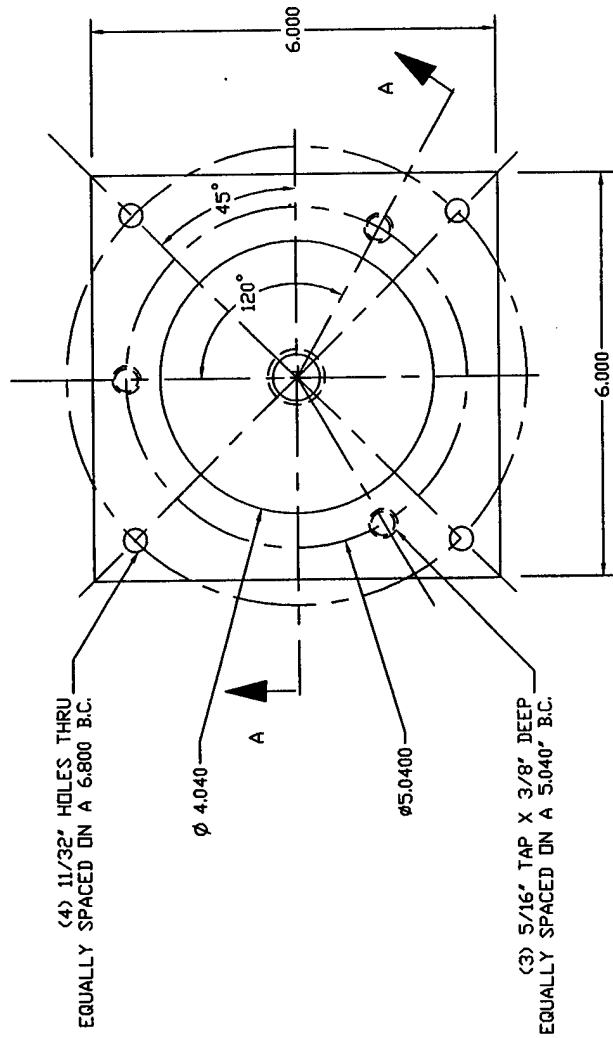

(4) 11/32" HOLES THRU  
EQUALLY SPACED ON A 6.800" B.C.

(3) 5/16" TAP X 3/8" DEEP  
EQUALLY SPACED ON A 5.040" B.C.

<b>Mechanical Solutions, Inc.</b> Engineering Analysis, Test & Technology	
NAME	Lower Flange
MATERIAL	
DRAWN	APPROVED
DWG NO.	
SCALE 1:2.5	DATE 6/23/99
SHEET 1	of 1
REV	0

EXCEPT AS OTHERWISE NOTED:  
 X.XXX = +/- 0.0005  
 X.XX = +/- 0.005  
 X.X = +/- 0.010  
 All diameters concentric to within 0.001  
 Flatness, Parallelism, and perpendicularity within +/- 0.001  
 All dimensions are in inches

Figure A-5

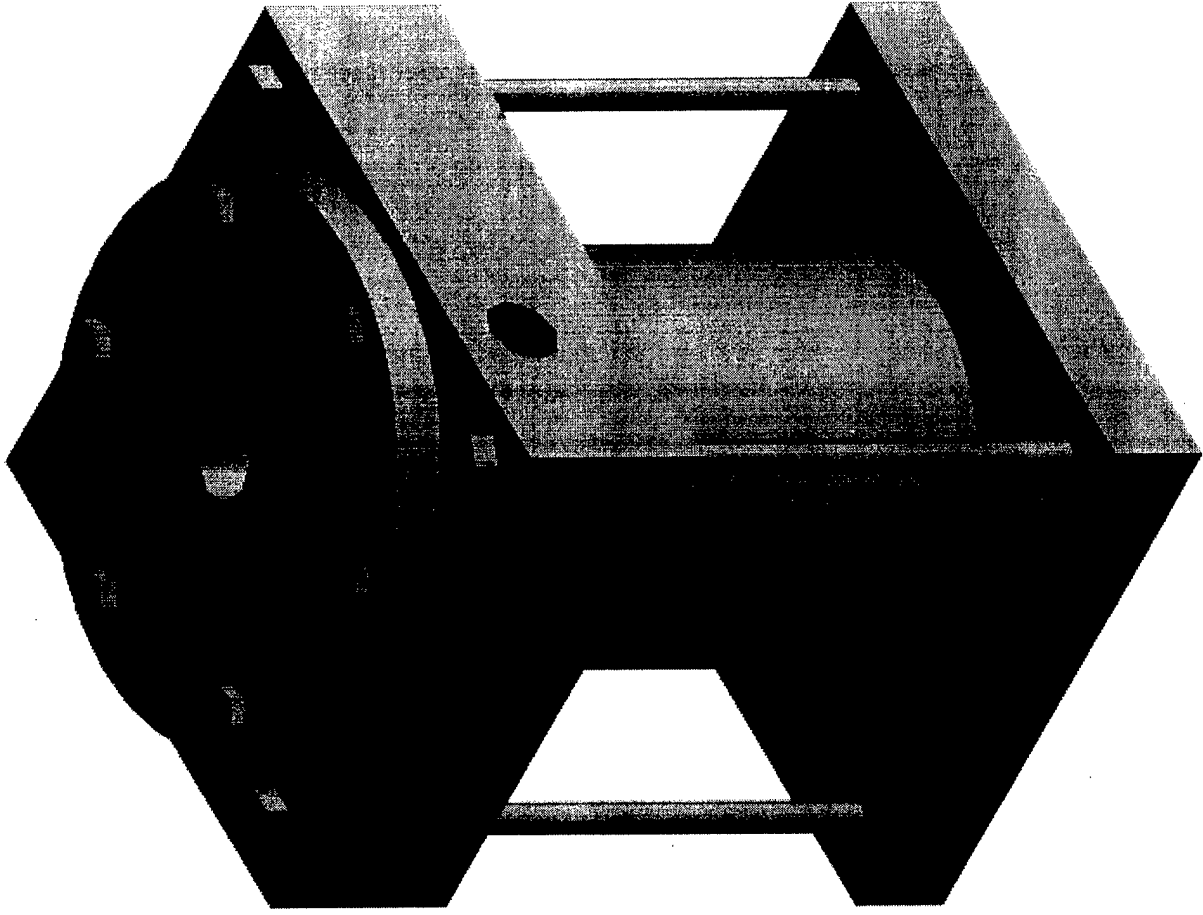

Figure A-6: Perspective View of Bench-Top Model

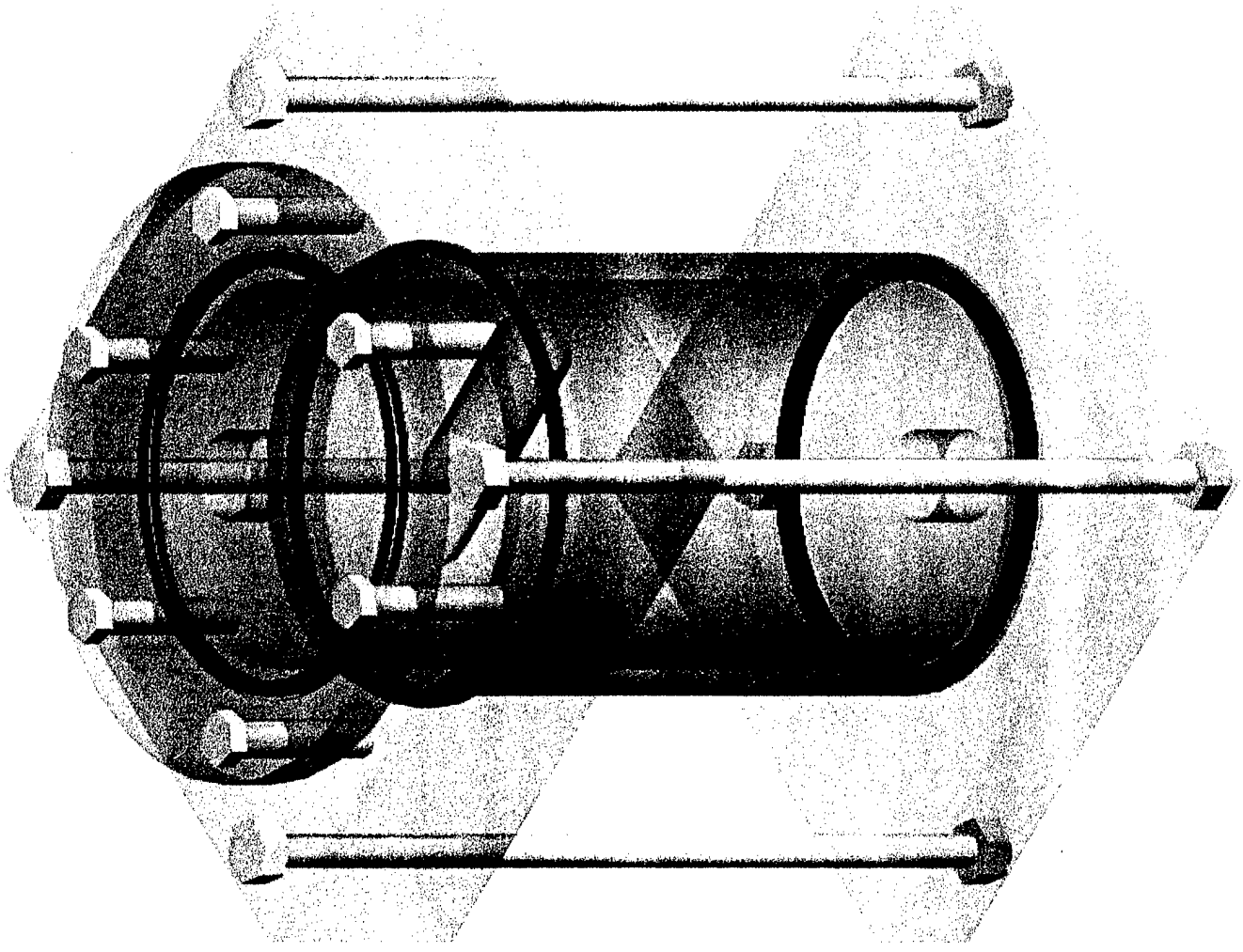

Figure A-7: Perspective Transparent View of Bench-Top Model

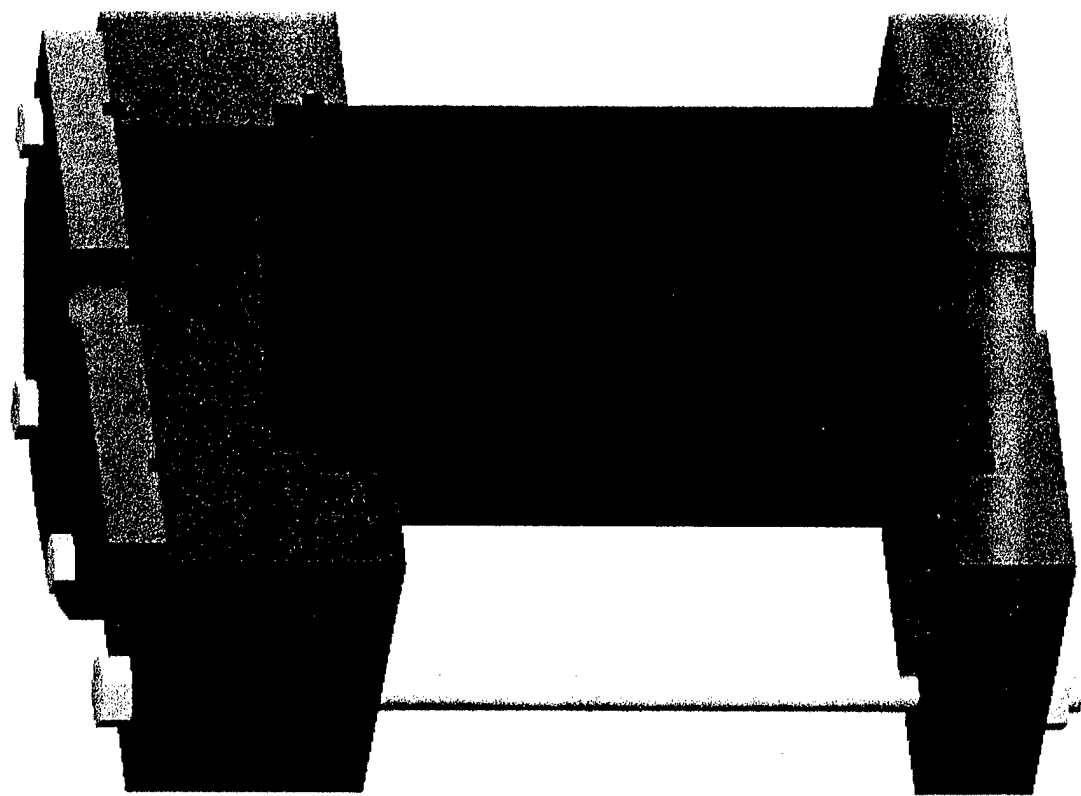
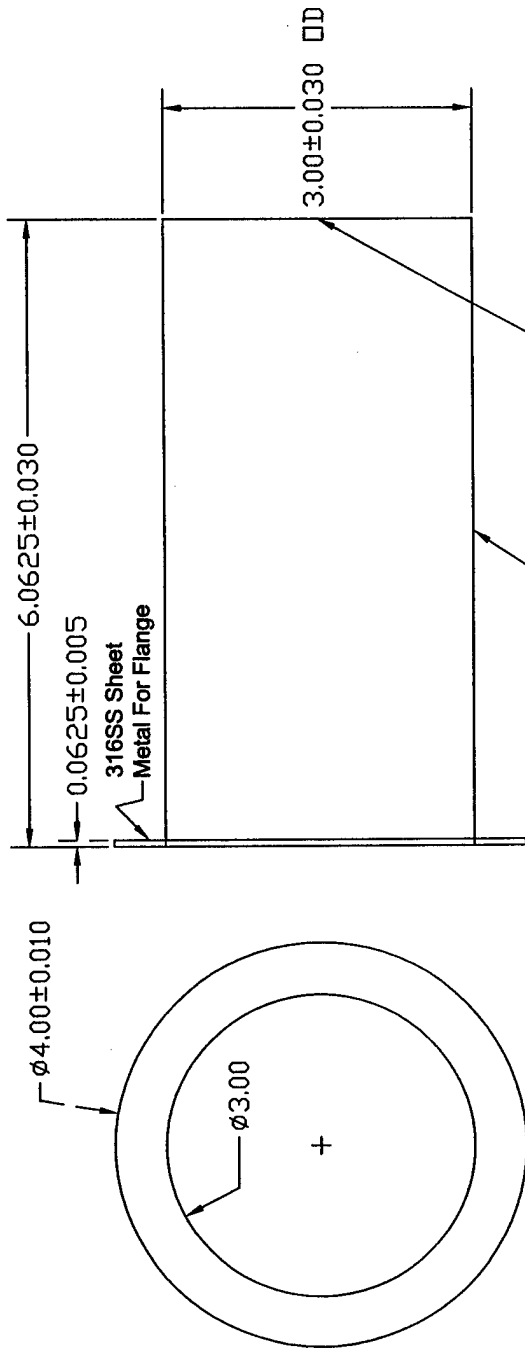

Figure A-8: Perspective Cut-Away View of Bench-Top Model



Blank

Perforated Tube or Porous Metal Filter Media

EXCEPT AS OTHERWISE NOTED:

X.XXXX = +/- 0.0005  
 X.XXX = +/- 0.005  
 X.XX = +/- 0.010

All diameters concentric to within 0.001

Flatness, Parallelism, and Perpendicularity within +/- 0.001

All dimensions are in inches

**Mechanical Solutions, Inc.**  
 Engineering Analysis, Test & Technology

NAME

Membrane Cartridge for Bench-Top

MATERIAL

DRAWN

APPROVED

DWG NO.

REV

0

SCALE NTS

DATE 7/15/99

SHEET 1 of 1

Figure A-9

**APPENDIX B**

**FEA Results for Housing Structure**

```

ANSYS 5.5.1
JUN 25 1999
13:59:36
NODAL SOLUTION
STEP=1
SUB =1
TIME=1
SEQV      (AVG)
DMX =.019315
SMN =12.906
SMX =2852
SMXB=3089
12.906
328.342
643.778
959.213
1275
1590
1906
2221
2536
2852

```

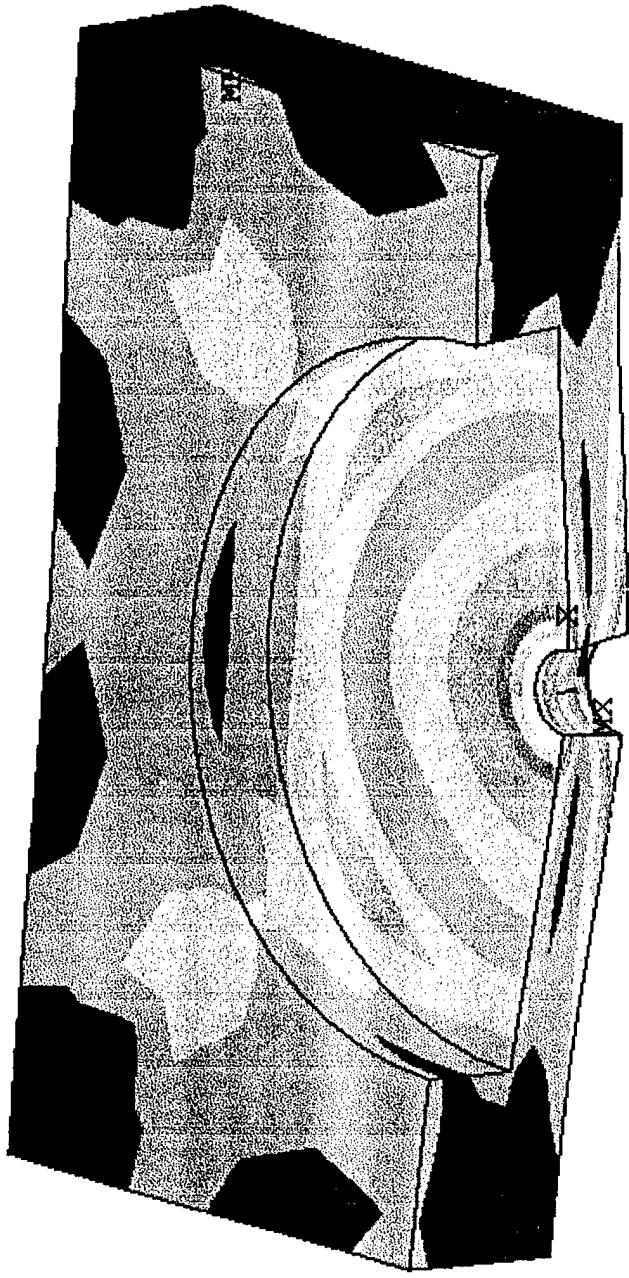

Stress Contours of Bottom Plate under 100 PSI Pressure

Figure B-1

```

ANSYS 5.5.1
DEC 9 1999
13:24:51
NODAL SOLUTION
STEP=1
SUB =1
TIME=1
SEQV      (AVG)
DMX  =.019315
SMN  =12.906
SMX  =2852
SMXB=3089
      12.906
      328.342
      643.778
      959.213
      1275
      1590
      1906
      2221
      2536
      2852

```

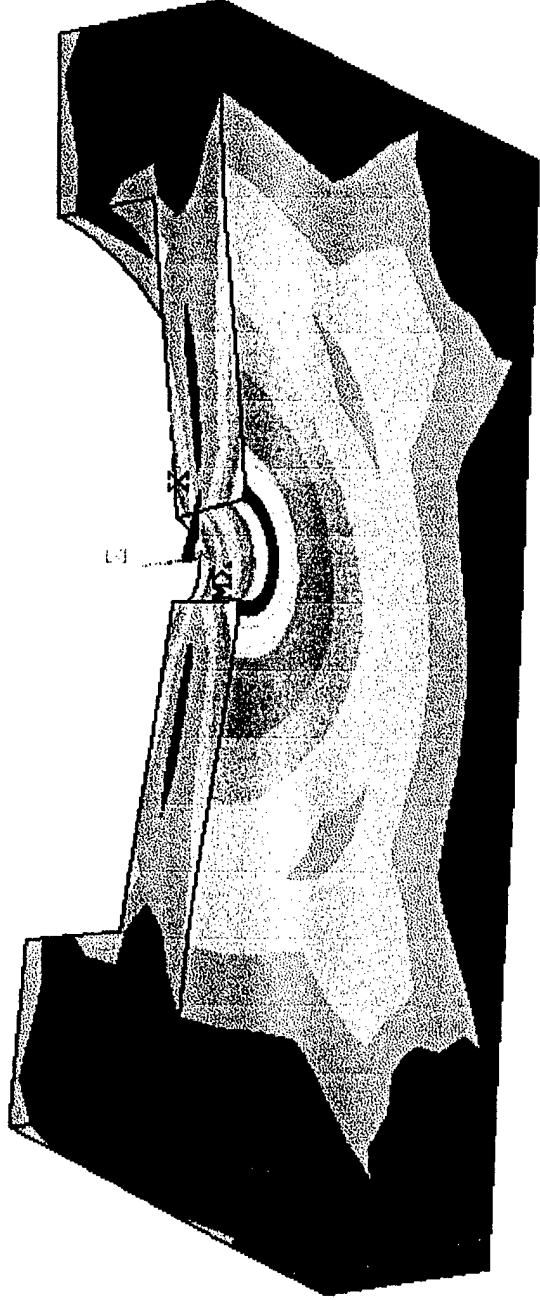

Stress Contours of Bottom Plate under 100 PSI Pressure

Figure B-2

ANSYS 5.5.1  
JUN 25 1999  
14:17:51  
DISPLACEMENT  
STEP=1  
SUB =1  
TIME=1  
RSYS=0  
DMX =.019315  
SEPC=41.864

DSCA=15.532  
XV =.232403  
YV =-.696277  
ZV =.679107  
\*DIST=3.618  
\*YF =1.507  
\*ZF =.355412  
A-ZS=-16.893  
Z-BUFFER  
EDGE

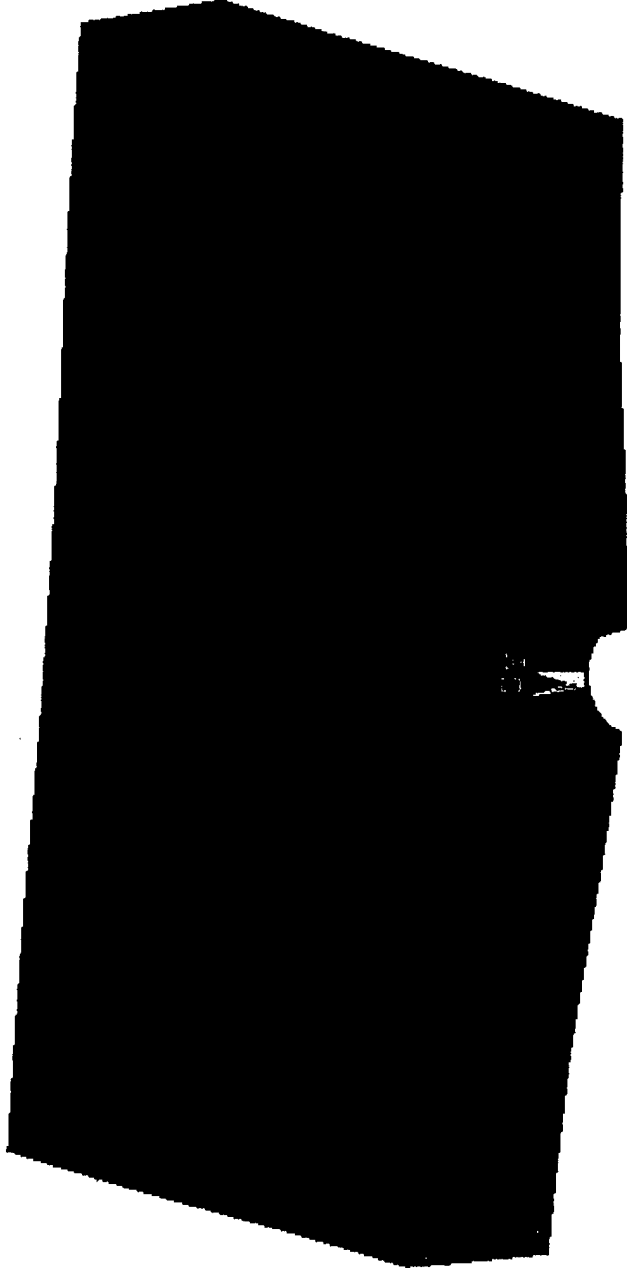

Deformation of bottom plate, exaggerated 15 times

```

ANSYS 5.5.1
JUN 25 1999
12:55:16
NODAL SOLUTION
STEP=1
SUB =1
TIME=1
SEQV      (AVG)
PowerGraphics
EFACET=1
AVRES=Mat
DMX =.002935
SMN =44.452
SMX =761.249
44.452
124.096
203.74
283.385
363.029
442.673
522.317
601.961
681.605
761.249

```

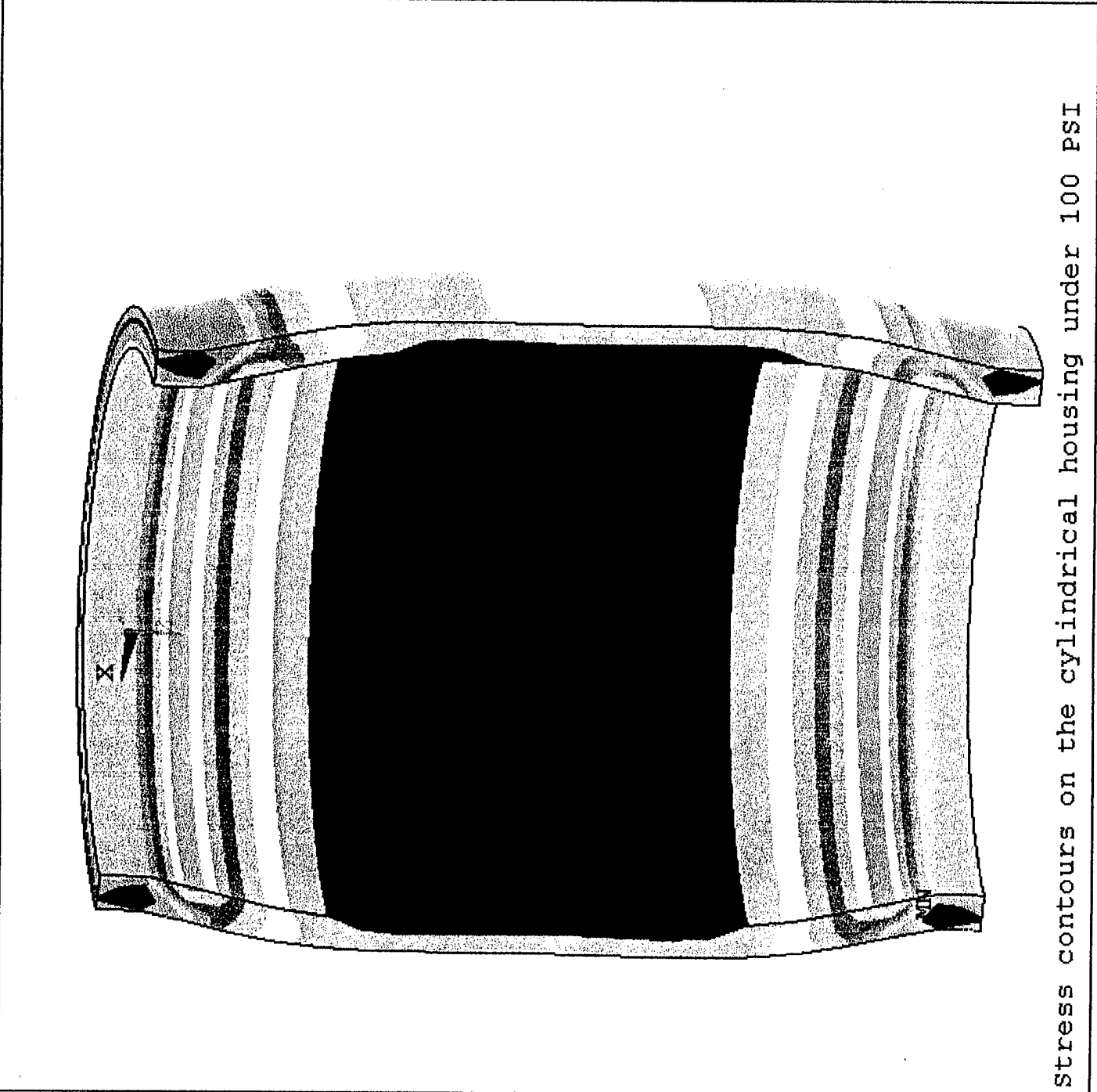

Stress contours on the cylindrical housing under 100 PSI

```
ANSYS 5.5.1
JUN 25 1999
12:59:36
DISPLACEMENT
STEP=1
SUB =1
TIME=1
PowerGraphics
EFACET=1
AVRES=Mat
DMX =.002935

DSCA=93.696
XV =-.49096
YV =-.85799
ZV =-.15106
DIST=3.364
YF =1.124
ZF =2.75
A-ZS=-76.184
Z-BUFFER
EDGE
```

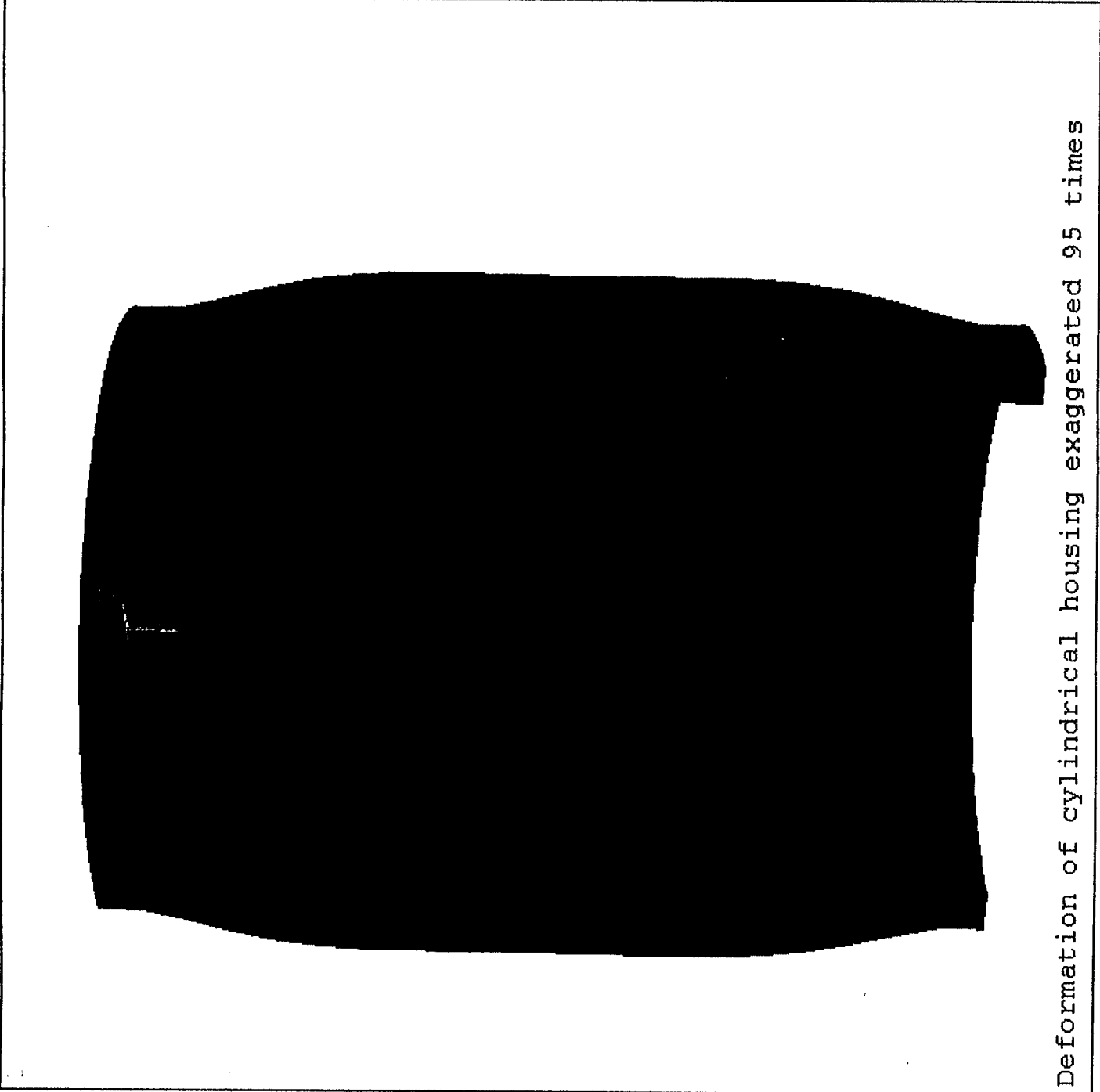

Deformation of cylindrical housing exaggerated 95 times

Figure B-5

```

ANSYS 5.5.1
JUN 25 1999
13:40:17
NODAL SOLUTION
STEP=1
SUB =1
TIME=1
SEQV      (AVG)
PowerGraphics
EFACET=1
AVRES=Mat
DMX =.00634
SMN =55.054
SMX =1503
55.054
215.895
376.735
537.575
698.416
859.256
1020
1181
1342
1503

```

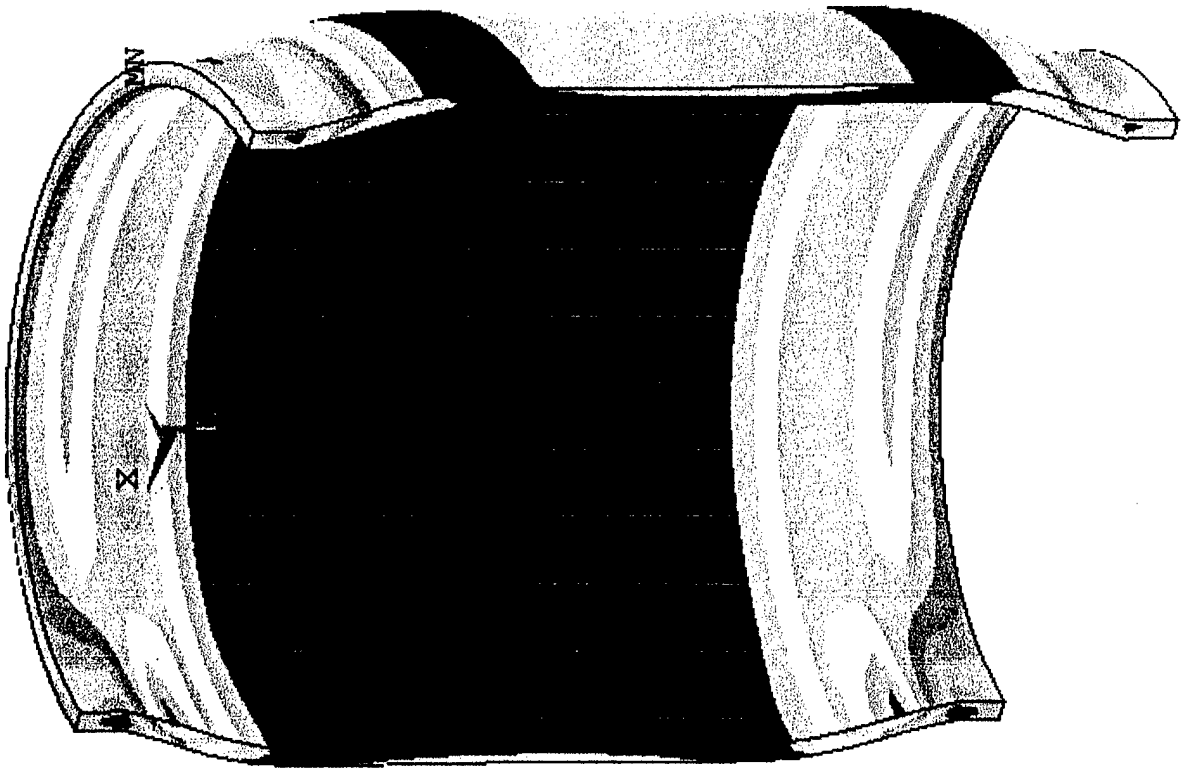

stress contours on the cylindrical housing under 100 PSI,  $t=1/8"$

Figure B-6

**APPENDIX C**

**Information of Test Loop and Test Method**

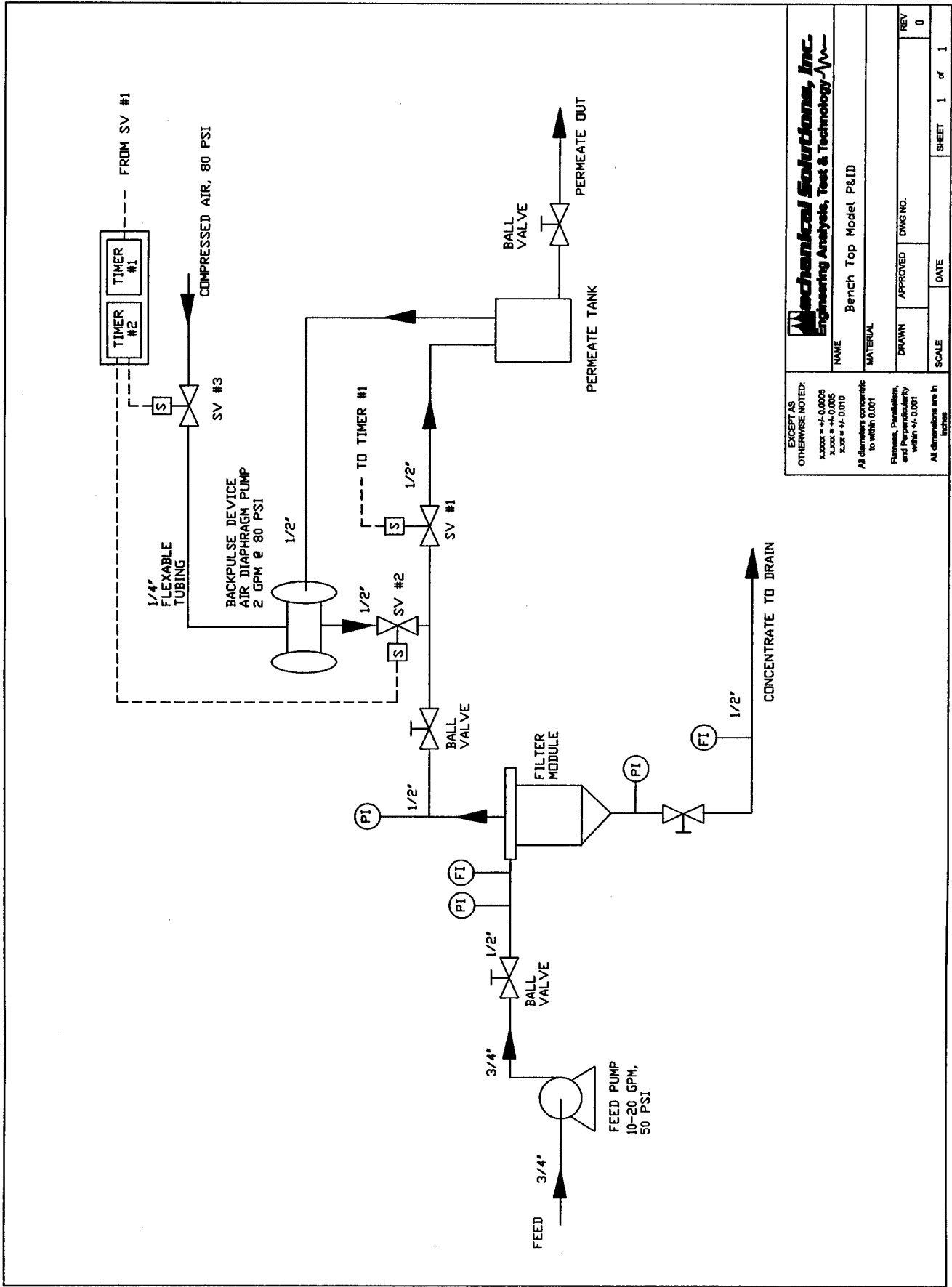

Figure C-1

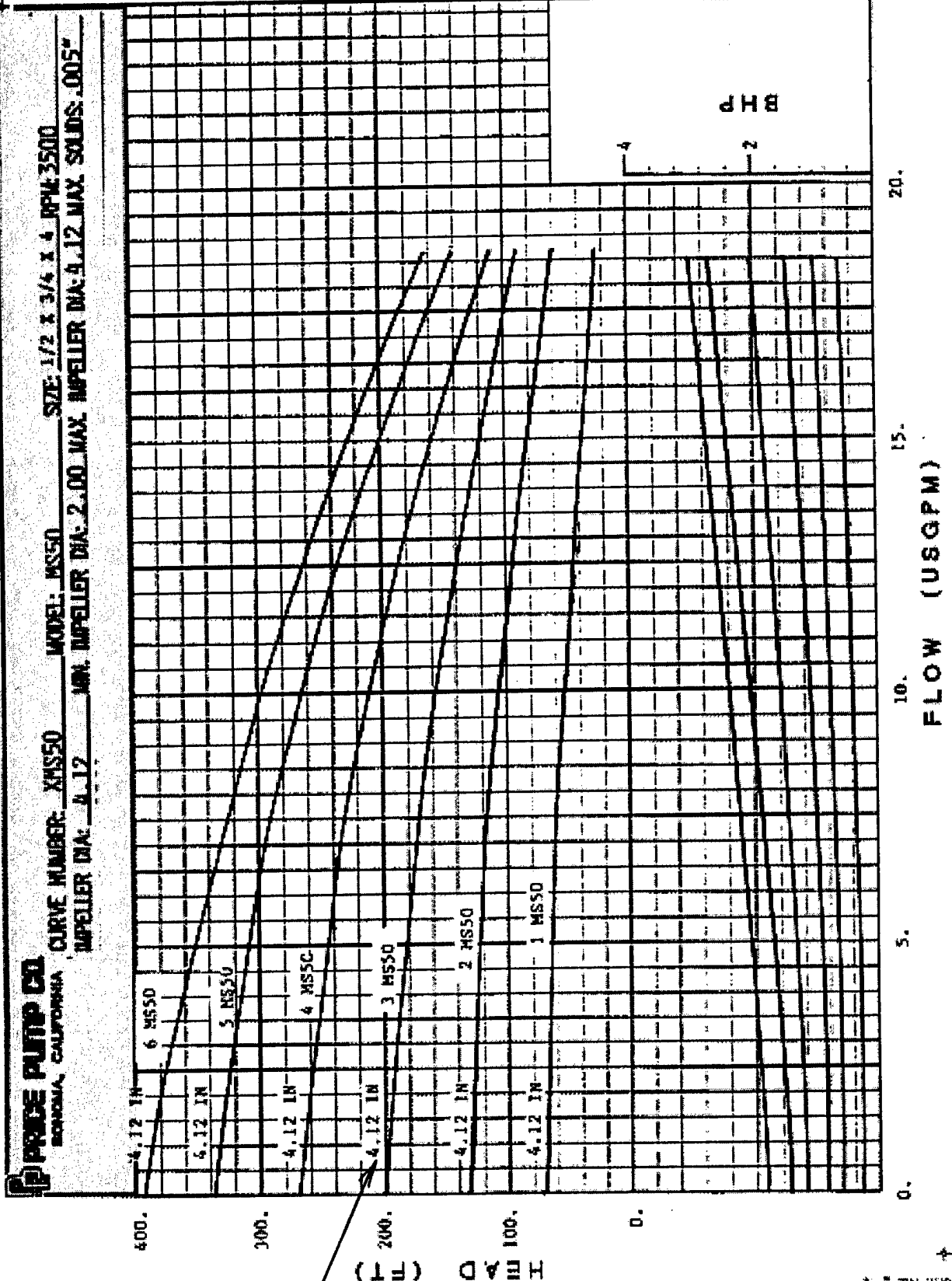

Figure C-2: Performance Curve of Test Loop Feed Pump

**POWDER  
TECHNOLOGY  
INCORPORATED**

**PRODUCT LIST PP2G1  
ISO 12103-1 ARIZONA  
TEST DUST CONTAMINANTS  
FINE AND COARSE GRADES**

P.O. BOX 1464, BURNSVILLE, MINNESOTA 55337  
PHONE: (612) 894-8737

FAX: (612) 894-0734

TYPICAL CHEMICAL ANALYSIS

<u>Chemical</u>	<u>% of Weight</u>	<u>Chemical</u>	<u>% of Weight</u>
SiO <sub>2</sub>	68 - 76	MgO	1 - 2
Al <sub>2</sub> O <sub>3</sub>	10 - 15	TiO <sub>2</sub>	0.5 - 1.0
Fe <sub>2</sub> O <sub>3</sub>	2 - 5	K <sub>2</sub> O	2 - 5
Na <sub>2</sub> O	2 - 4		
CaO	2 - 5	Loss on Ignition	2 - 5

ISO TEST DUST PARTICLE SIZE DISTRIBUTIONS BY VOLUME %

<u>Size in Microns</u>	<u>ISO 12103-A2</u>	<u>ISO 12103-A4</u>
	<u>Fine Grade % Less Than</u>	<u>Coarse Grade % Less Than</u>
1	2.5 - 3.5	6 - 1
2	10.5 - 12.5	2.2 - 3.7
3	18.5 - 22.0	4.2 - 6.0
4	25.5 - 29.5	6.2 - 8.2
5	31 - 36	8.0 - 10.5
7	41 - 46	12.0 - 14.5
10	50 - 54	17.0 - 22.0
20	70 - 74	32.0 - 36.0
40	88 - 91	57.0 - 61.0
80	99.5 - 100	87.5 - 89.5
120	100	97.0 - 98.0
180		99.5 - 100
200		100

PACKAGING OPTIONS AND COST

<u>Container</u>	<u>ISO FINE</u>	<u>ISO COARSE</u>
	<u>(3.5 kg/jar) \$/Container</u>	<u>(4.5 kg/jar) \$/Container</u>
4 Liter Jar, 1 - 5 jars	\$ 45.00	\$ 45.00
4 Liter Jar, 6 - 23 jars	\$ 40.00	\$ 40.00
4 Liter Jar, 24 - 51 jars	\$ 37.00	\$ 37.00
4 Liter Jar, 52+ jars	\$ 35.00	\$ 35.00
120 Liter Drum	\$1030.00	\$1030.00
220 Liter Drum	\$1840.00	\$1840.00

**NOTE:**

- 1) Orders less than \$200.00 are subject to a \$20.00 handling fee.
- 2) Prices are in U.S. Dollars.
- 3) Each shipment will contain a minimum number of batches.
- 4) Typical batch size is 4000 pounds.
- 5) Each batch shipped with particle size distribution as analyzed with a Coulter Multisizer IIe.
- 6) F.O.B. - Shipping Point
- 7) Prices are subject to change without notice.

1 July 1996



# Standard Test Method for Particulate Contamination in Aviation Fuels by Laboratory Filtration<sup>1</sup>

This standard is issued under the fixed designation D 5452; the number immediately following the designation indicates the year of original adoption or, in the case of revision, the year of last revision. A number in parentheses indicates the year of last reapproval. A superscript epsilon ( $\epsilon$ ) indicates an editorial change since the last revision or reapproval.

## 1. Scope

1.1 This test method covers the gravimetric determination by filtration of particulate contaminant in a sample of aviation turbine fuel delivered to a laboratory.

1.1.1 The sample is filtered through a test membrane and a control membrane using vacuum. The mass change difference identifies the contaminant level per unit volume.

1.2 The values stated in SI units are to be regarded as the standard. The values given in parentheses are for information only.

1.3 *This standard does not purport to address all of the safety concerns, if any, associated with its use. It is the responsibility of the user of this standard to establish appropriate safety and health practices and determine the applicability of regulatory limitations prior to use.* For specific hazard statements, see 4.2, 7.3, 7.5, 11.3, and Appendix X1. Before using this standard, refer to supplier's safety labels, material safety data sheets, and technical literature.

## 2. Referenced Documents

### 2.1 ASTM Standards:

- D 56 Test Method for Flash Point by Tag Closed Tester<sup>2</sup>
- D 93 Test Methods for Flash Point by Pensky-Martens Closed Cup Tester<sup>2</sup>
- D 1193 Specification for Reagent Water<sup>3</sup>
- D 1535 Practice for Specifying Color by the Munsell System<sup>4</sup>
- D 1655 Specification for Aviation Turbine Fuels<sup>2</sup>
- D 2244 Test Method for Calculation of Color Differences from Instrumentally Measured Color Coordinates<sup>4</sup>
- D 2276 Test Method for Particulate Contaminant in Aviation Fuel by Line Sampling<sup>2</sup>

D 3828 Test Methods for Flash Point by Small Scale Closed Tester<sup>5</sup>

D 4306 Practice for Aviation Fuel Sample Containers for Tests Affected by Trace Contamination<sup>5</sup>

D 4865 Guide for Generation and Dissipation of Static Electricity in Petroleum Fuel Systems<sup>6</sup>

## 3. Terminology

### 3.1 Definitions:

3.1.1 *bond, v*—to connect two parts of a system electrically by means of a bonding wire to eliminate voltage differences.

3.1.2 *ground, vt*—to connect electrically with ground (earth).

3.1.3 *membrane filter, n*—a porous article of closely controlled pore size through which a liquid is passed to separate matter in suspension.

3.1.3.1 *Discussion*—Material of closely controlled pore size meeting tests specified in RR: D02-1012.

3.1.4 *particulate, adj*—of or relating to minute separate particles.

3.1.4.1 *Discussion*—Solids generally composed of oxides, silicates, and fuel insoluble salts.

3.1.5 *volatile fuels*—relatively wide boiling range volatile distillate.

3.1.5.1 *Discussion*—These are identified as Jet B in Specification D 1655 or the military grade known as JP-4. Any fuel or mixture having a flash point less than 38°C must be considered volatile.

## 4. Summary of Test Method

4.1 A known volume of fuel is filtered through a pre-weighed test membrane filter and the increase in membrane filter mass is weight determined after washing and drying. The change in weight of a control membrane located immediately below the test membrane filter is also determined. The particulate contaminant is determined from the increase in mass of the test membrane relative to the control membrane filter.

4.2 In order to ensure safety in handling, the method requires that volatile fuels be transferred from the sample container to the funnel without pouring. Fuels having a verified flash point greater than 38°C (refer to Test Methods D 56,

<sup>1</sup> This test method is under the jurisdiction of ASTM Committee D-2 on Petroleum Products and Lubricants and is the direct responsibility of Subcommittee D02.J0.10 on Fuel Cleanliness.

Current edition approved June 10, 1998. Published November 1998. This document was previously published as ES 19. Last previous edition D 5452 – 97.

This standard has been separated from D 2276 and has been modified primarily to establish improved safety measures. Last previous edition was D 2276 – 89.

<sup>2</sup> *Annual Book of ASTM Standards*, Vol 05.01.

<sup>3</sup> *Annual Book of ASTM Standards*, Vol 11.01.

<sup>4</sup> *Annual Book of ASTM Standards*, Vol 06.01.

<sup>5</sup> *Annual Book of ASTM Standards*, Vol 05.02.

<sup>6</sup> *Annual Book of ASTM Standards*, Vol 05.03.

D 93, or D 3828) may be transferred by pouring the sample from the sample container directly into the funnel. Bonding the sample container to the funnel is required.

NOTE 1—Warning: Volatile fuels such as JP-4 and Jet B or mixtures having flash points below 38°C have been ignited by electrostatic discharges when poured through membrane filters.

4.3 Appendix X1 describes safety precautions to avoid static discharge in filtering fuel through membranes.

5. Significance and Use

5.1 This test method provides a gravimetric measurement of the particulate matter present in a sample of aviation turbine fuels delivered to a laboratory for evaluation. The objective is to minimize these contaminants to avoid filter plugging and other operational problems. Although tolerable levels of particulate contaminants have not yet been established for all points in fuel distribution systems, the total contaminant measurement is normally of most interest.

6. Apparatus

6.1 Analytical Balance, single- or double-pan, the precision standard deviation of which must be 0.07 mg or better.

6.2 Oven, of the static type (without fan-assisted air circulation), controlling to 90 ± 5°C.

6.3 Petri Dishes, approximately 125 mm in diameter with removable glass supports for membrane filters.

6.4 Forceps, flat-bladed with unserrated, non-pointed tips.

6.5 Vacuum System.

6.6 Test Membrane Filters, <sup>7,8</sup> plain, 47-mm diameter, nominal pore size 0.8-µm (see Note 2).

<sup>7</sup> All available membrane filters are not suitable for this application. Apparatus considered for this application shall be checked by the user for suitability in accordance with the requirements of RR:D02-1012, 1994 revision.

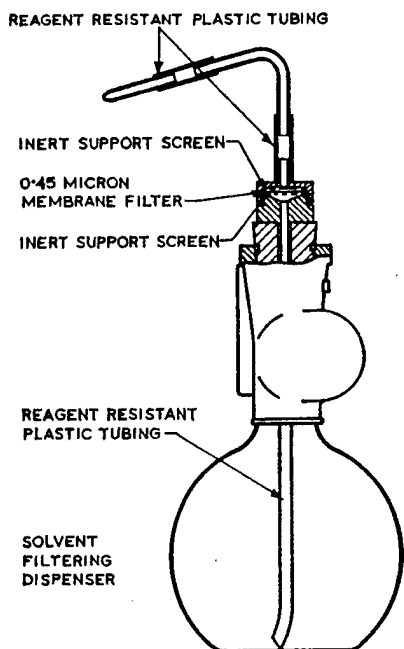

FIG. 1 Apparatus for Filtering and Dispensing Flushing Fluid

6.7 Control Membrane Filters, <sup>7,8</sup> 47-mm diameter, nominal pore size 0.8-µm. (Gridded control membrane filters may be used for purpose of identification.)

NOTE 2—Matched weight membrane filters, <sup>7</sup> 47-mm diameter, nominal pore size 0.8 µm, may be used as test and control membrane filters if so desired. Use of matched-weight membrane filters precludes the necessity for carrying out subsequently the procedures detailed in Section 10.

6.8 Dispenser for Flushing Fluid, 0.45-µm membrane filters to be provided in the delivery line (see Fig. 1).

6.9 Air Ionizer, for the balance case. See Note 3 and Note 4.

NOTE 3—When using a solid-pan balance the air ionizer may be omitted provided that, when weighing a membrane filter, it is placed on the pan so that no part protrudes over the edge of the pan.

NOTE 4—Air ionizers should be replaced within 1 year of manufacture.

6.10 Filtration Apparatus, of the type shown in Fig. 2. It consists of a funnel and a funnel base with a filter support such that a membrane filter can be gripped between the sealing surface and the base by means of a locking ring. Use a metal funnel with at least a 70-mm diameter at the top.

6.11 Support Apparatus, as shown in Fig. X3.1, having adjustable height, integral spill collection pan at the base and an edge on the can shelf to prevent the can from slipping off. The shelf is slotted. Refer to Appendix X2 for fabrication details.

6.12 Dispensing Cap or Plug, with approximately 9.5 mm inside diameter hose barb 32 mm long on which a 75 to 100 mm long piece of fuel resistant, flexible, plastic tubing is installed (see Fig. 2). The closure gasket shall be made of a fuel resistant material. A paper composition material is not acceptable.

6.13 Feed Container, shall be a 3.8 to 5 L (1 gal) epoxy lined sample can, preferably the same container in which the sample was collected.

6.14 Receiving Flask, shall be glass or metal. A graduated glass flask is preferred so that the space remaining for fuel can be observed. The filtration apparatus is fitted to the top of the flask. The flask shall be fitted with a side arm to connect the vacuum system. The flask should be large enough to contain the sample and flushing fluids.

6.15 Safety Flask, shall be glass containing a sidearm attached to the receiving flask with a fuel and solvent resistant rubber hose and shall be connected to the vacuum system.

6.16 Ground/Bond Wire, #10 thru #19 (0.912–2.59 mm) bare stranded flexible, stainless steel or copper installed in the flasks and grounded as shown in Fig. 2. If a metallic flask(s) is used instead of glass, the flask(s) must be grounded.

6.17 Plastic Film, polyethylene or any other clear film not adversely affected by flushing fluids.

6.18 Multimeter/VOM, used for determining whether electrical continuity is 10 ohms or less between 2 points.

7. Reagents

7.1 Purity of Reagents—Reagent grade chemicals shall be used in all tests. Unless otherwise indicated, it is intended that

<sup>8</sup> A list of suppliers who have provided data indicating their membranes, field monitors, and field monitor castings are in accordance with the requirements of RR:D02-1012 is available from ASTM Headquarters. To obtain the research report, data, and list of suppliers request RR:D02-1012, 1994 revision.

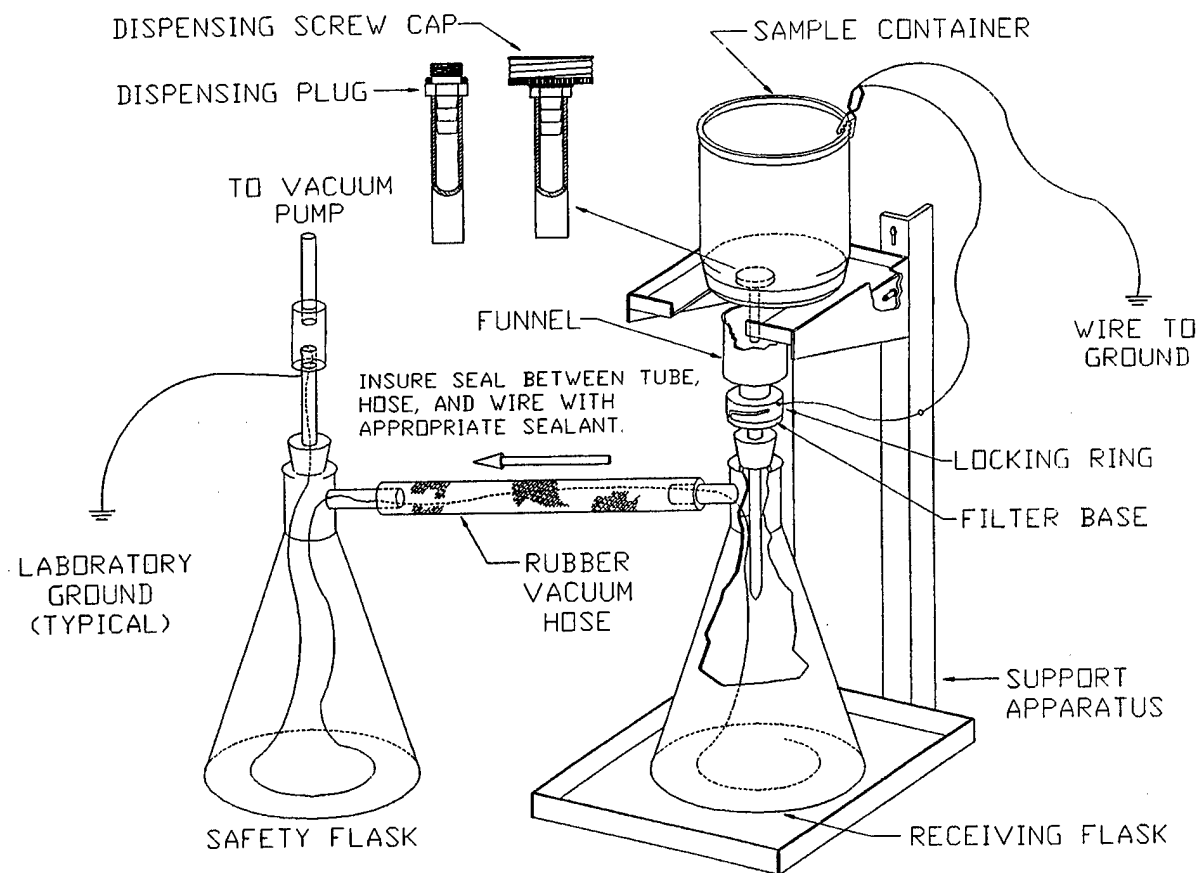

FIG. 2 Apparatus for Determining Total Contaminant

all reagents shall conform to the specifications of the Committee on Analytical Reagents of the American Chemical Society, where such specifications are available.<sup>9</sup> Other grades may be used, provided it is first ascertained that the reagent is of sufficiently high purity to permit its use without lessening the accuracy of the determination.

7.2 *Purity of Water*—Unless otherwise indicated references to water shall be understood to mean reagent water as defined by Type III of Specification D 1193.

7.3 *Isopropyl Alcohol*, (**Warning**—See Note 5.)

NOTE 5—**Warning:** Flammable.

7.4 *Liquid Detergent*, water-soluble.

7.5 *Flushing Fluids*—Petroleum spirit (also known as petroleum ether or IP Petroleum Spirit 40/60) (**Warning**—see Note 6) having boiling range from 35 to 60°C.

NOTE 6—**Warning:** Extremely flammable. Harmful if inhaled. Vapors are easily ignited by electrostatic discharges, causing flash fire.

7.6 *Filtered Fluids*—Filtered fluids are fluids filtered through a nominal 0.45- $\mu$ m membrane filter. Filtered fluids are

most conveniently obtained by means of the solvent filtering dispenser described in Fig. 1.

## 8. Sampling

8.1 All containers and their closures, sampling lines, and other equipment used in obtaining the sample for analysis must be thoroughly cleaned as described in Section 9. Containers used must conform to the criteria set forth in Practice D 4306.

8.2 To obtain a representative sample from a fuel stream and to avoid external contamination, the sample may be drawn from the flushing line of a field sampling kit. Ensure that the line is first flushed with the fuel to be sampled and that the line is externally clean.

8.3 Whether or not a sampling kit is available, suitable precautions must be taken to avoid sample contamination by the use of a suitable sampling point in accordance with Test Method D 2276. If the quick-disconnect sampling connection is not used, a stainless steel ball or plug type valve should be selected as its internal design avoids the possibility of trapping or generating solid contaminant. Samples that are collected for general laboratory or chemical analysis are not necessarily suitable for this test method because insufficient care may have been taken to avoid particulate contamination.

8.4 Where possible a 3.8 to 5-L (1-gal) fuel sample should be taken, preferably in the same container that will be used in the test to avoid the need to transfer from one container to another with increased possibility of contamination. Results

<sup>9</sup> *Reagent Chemicals, American Chemical Society Specifications*, American Chemical Society, Washington, DC. For suggestions on the testing of reagents not listed by the American Chemical Society, see *Analar Standards for Laboratory Chemicals*, BDH Ltd., Poole, Dorset, U.K., and the *United States Pharmacopoeia and National Formulary*, U.S. Pharmacopoeial Convention, Inc. (USPC), Rockville, MD.

obtained by taking other sample volumes may have different precisions.

8.5 The sample volume must be quoted with the results. If the sample was transferred from one container to another before the test was performed, this must also be noted with the test results.

## 9. Preparation of Apparatus and Sample Containers

9.1 Clean all components of the filtration apparatus, sample containers, and their closures as described in 9.1.1-9.1.7. Clean petri dishes as described in 9.1.2-9.1.7.

9.1.1 Remove any labels, tags, and so forth.

9.1.2 Wash with warm tap water containing detergent.

9.1.3 Rinse thoroughly with warm tap water.

9.1.4 Rinse thoroughly with reagent water. Container caps should be handled only externally with clean laboratory crucible tongs during this and subsequent washing.

9.1.5 Rinse thoroughly with filtered isopropyl alcohol.

9.1.6 Rinse thoroughly with filtered flushing fluid.

9.1.7 Keep a clean piece of plastic film rinsed with filtered flushing fluid over the top of the sample container until the closure is installed. Similarly protect the funnel opening of the assembled filtration apparatus with clean plastic film until ready for use.

## 10. Preparation of Test and Control Membrane Filters

10.1 Two 47-mm membrane filters of nominal pore size 0.8- $\mu\text{m}$  are required: a test and a control membrane filter. Matched-weight membrane filters may be used if so desired (see Note 2). If matched-weight membrane filters are used, it is unnecessary to carry out the procedures detailed in this section because they had been carried out previously by the membrane filter supplier. The two membrane filters used for each individual test should be identified by marking the petri dishes used as containers. Glassware used in preparation of membrane filters must be cleaned as described in 9.1.

10.1.1 Using forceps place the test and control membrane filters side by side in a clean petri dish. To facilitate handling, the membrane filters should rest on clean glass support rods in the petri dish.

10.1.2 Place the petri dish with its lid slightly ajar, in an oven at  $90 \pm 5^\circ\text{C}$  and leave it for 30 min.

10.1.3 Remove the petri dish from the oven and place it near the balance. The petri dish cover should be ajar but still protecting the membrane filters from contamination from the atmosphere. Allow 30 min for the membrane filters to come to equilibrium with the ambient air temperature and humidity.

10.1.4 Remove the control membrane filter from the petri dish with forceps, handling by the edge only, and place it centrally on the weighing pan. Weigh it and return it to the petri dish.

10.1.5 Repeat 10.1.4 for the test membrane filter. Record the membrane filter masses.

10.1.6 Using clean forceps, place the weighed control membrane filter centrally on the membrane filter support of the filtration apparatus (see Fig. 2). Place the weighed test membrane filter on top of the control membrane filter. Install the funnel. Do not remove the plastic film from the funnel opening until ready to start filtration.

## 11. Procedure

11.1 Take precautions to minimize apparatus contamination from airborne dust. Use a protective hood or cover. Clean all equipment used for handling samples and membrane filters before use as described for petri dishes in 9.1.

11.2 With the membrane filter in place, perform a continuity test using a multimeter between the funnel and the filter holder. The meter shall read 10 ohms or less.

11.3 The assembled apparatus shall be grounded as shown in Fig. 2, by connecting a wire to a laboratory ground from the locking ring of the filtration assembly to the support stand and to the sample container. Another ground wire is required from the inside of the receiving and safety flasks and from the sample container.

11.4 Thoroughly clean the outside of the sample container in the region of the closure by washing with detergent in water and rinsing with tap water and filtered isopropyl alcohol. Shake the container vigorously for about  $\frac{1}{2}$  min. Remove the closure; remove any external contaminant that may be present in the threads on the sample container by washing with filtered flushing fluid ensuring that none of the washings enter the container.

11.5 Transfer the fuel in the container to the filter funnel.

11.5.1 After removing the closure from the sample container and cleaning the threads, screw the closure from 6.12 on the container. If the closure is not clean, rinse thoroughly with filtered flushing fluid and dry with compressed air before use. Slip a length of plastic tubing mentioned in 6.12 snugly over the hose barb. If the closure will not fit the original sample container, shake the original container briefly and quickly transfer the sample to an appropriate container that has been rinsed as described in Section 9. Tighten the dispensing cap or plug on this container.

11.5.2 Assemble the receiving flask, preweighed filter(s) and funnel as a unit, and place on the pan of the support. Snap the support shelf on the support apparatus described in 6.11. The shelf should be positioned approximately 25 to 50 mm above the top of the funnel. Secure a grounding clip and wire to the container support and electrically ground in series as shown in Fig. 2.

NOTE 7—All of this apparatus should be mounted in an exhaust hood to minimize operator exposure to fumes.

11.5.3 Remove any labels from the container top, fold down any container handle present and double over or crimp the plastic tubing installed on the cap in 11.5.1 above. Grasp the container firmly and shake gently or agitate the container briefly and carefully release vapor pressure from the container by venting through the plastic tubing away from the face. Quickly crimp the tubing again and hold in place.

11.5.4 Carefully invert the container and position it over the shelf and funnel, releasing the tubing into the funnel just before resting it on the shelf.

NOTE 8—A small clamp, pinchcock or fingertip pressure may be used to assist in crimping the tubing.

11.5.5 As the funnel is filling, secure a grounding clip and wire to the container and electrically ground in series with all other grounds. When the fuel has ceased flowing into the

funnel, switch on vacuum source, stand well clear and allow the fuel to filter. Agitate the container every minute during filtration by grasping firmly on both sides of the container and lifting the can approximately 12 mm off of the base and briefly shake the container for approximately five seconds.

11.5.6 Move (swirl) the container about in order to drain any residual fuel into the funnel.

11.5.7 After fuel has filtered completely, disconnect the vacuum and record the volume of the filtered sample.

11.5.8 Rinse the inside and outside of cap or plug and tubing with approximately thirty millilitres of filtered flushing fluid, flushing directly into the funnel. Also rinse the test container with four 50 mL quantities of filtered flushing fluid to complete transference of the contaminant to the membrane filter. Reapply vacuum as necessary.

11.5.9 If the sample had been transferred from another container, rinse the original container with four 50 ml quantities of filtered flushing fluid to complete transference of the contaminant to the membrane filter. Attach ground wires as specified in 11.5.2. Reapply vacuum as needed to the funnel/flask assembly to flush rinse fluid through the filters. If a funnel was used to transfer to an appropriate container, rinse the funnel with 30 mL of filtered flushing fluid and on to the membrane filter.

11.5.10 Wash down the inside of the funnel and the outside joint between the funnel and filter base with filtered flushing fluid. With the vacuum applied, carefully separate the funnel from the filter base by releasing the locking ring. Wash the periphery of the membrane filter with filtered flushing fluid by directing a gentle stream of filtered flushing fluid from the edge to the center, taking great care not to wash any of the contaminant from the surface of the membrane filter. Maintain vacuum after the final washing only for the few seconds necessary to remove excess filtered flushing fluid from the membrane filter.

11.6 Using clean forceps, carefully remove the test and control membrane filters from the filter base, and place them in a clean, covered Petri dish. Dry and reweigh the membrane filters as described in 10.1.2-10.1.5, taking great care not to disturb the contaminant on the surface of the test membrane filter.

## 12. Calculation and Report

12.1 Subtract the initial mass of the test membrane filter,  $W_1$ , from the final mass,  $W_2$ .

12.2 Subtract the initial mass of the control membrane filter,  $W_3$ , from the final mass,  $W_4$ .

12.3 Calculate total contaminant in milligrams per litre as follows:

$$\frac{(W_2 - W_1) - (W_4 - W_3)}{\text{Volume filtered, } L} \quad (1)$$

NOTE 9—If matched-weight membranes have been used for the test (see Note 2), then  $W_1 = W_3$  and the corrected weight of contaminant in 12.3 becomes  $W_2 - W_4$ .

12.4 Report the particulate contamination to the nearest 0.01 mg/L, and also report the sample volume used in the test.

## 13. Precision and Bias

13.1 The precision of this test method as determined by interlaboratory results<sup>10</sup> is as follows:

13.1.1 *Repeatability*—The difference between successive results obtained by the same operator with the same apparatus under constant operating conditions on identical test material would, in the long run, in the normal and correct operation of the test method, exceed the following values in only one case in twenty:

Range	Repeatability
0 to 0.6 mg/L	$0.415x^{0.5}$

where:

$x$  = the mean of the two results.

13.1.2 *Reproducibility*—The difference between two single and independent results obtained by different operators working in different laboratories on identical test material would, in the long run, exceed the following values only in one case in twenty:

Range	Reproducibility
0 to 0.6 mg/L	$0.726x^{0.5}$

where:

$x$  = the mean of the two results.

13.1.3 Repeatability and reproducibility values for various values of  $x$  are given in Table 1.

13.2 *Bias*—The procedure given for the Determination of Particulate Contamination in Aviation Turbine Fuel by Laboratory Filtration has no bias since this property can be defined only in terms of a test method.

## 14. Keywords

14.1 aviation fuel; gravimetric contaminant; membrane color; membrane filter; particulate

<sup>10</sup> A report of the interlaboratory results and statistical analysis is available from ASTM by requesting RR:D02-1384.

**TABLE 1 Statistical Information for Particulate Contaminant**

Average Results, mg/L	0.1	0.2	0.3	0.4	0.5	0.6
Repeatability	0.13	0.18	0.22	0.26	0.29	0.32
Reproducibility	0.23	0.32	0.40	0.46	0.52	0.56

**APPENDIX D**

**Parametric Studies of Automatic Back-Flush**

Membrane: 3  $\mu$ m, SS 316L Sintered Fiber of Bekaert  
Trans-Membrane Pressure: 26 psi  
Back-Flush Cycle: 10 seconds / 1 minute

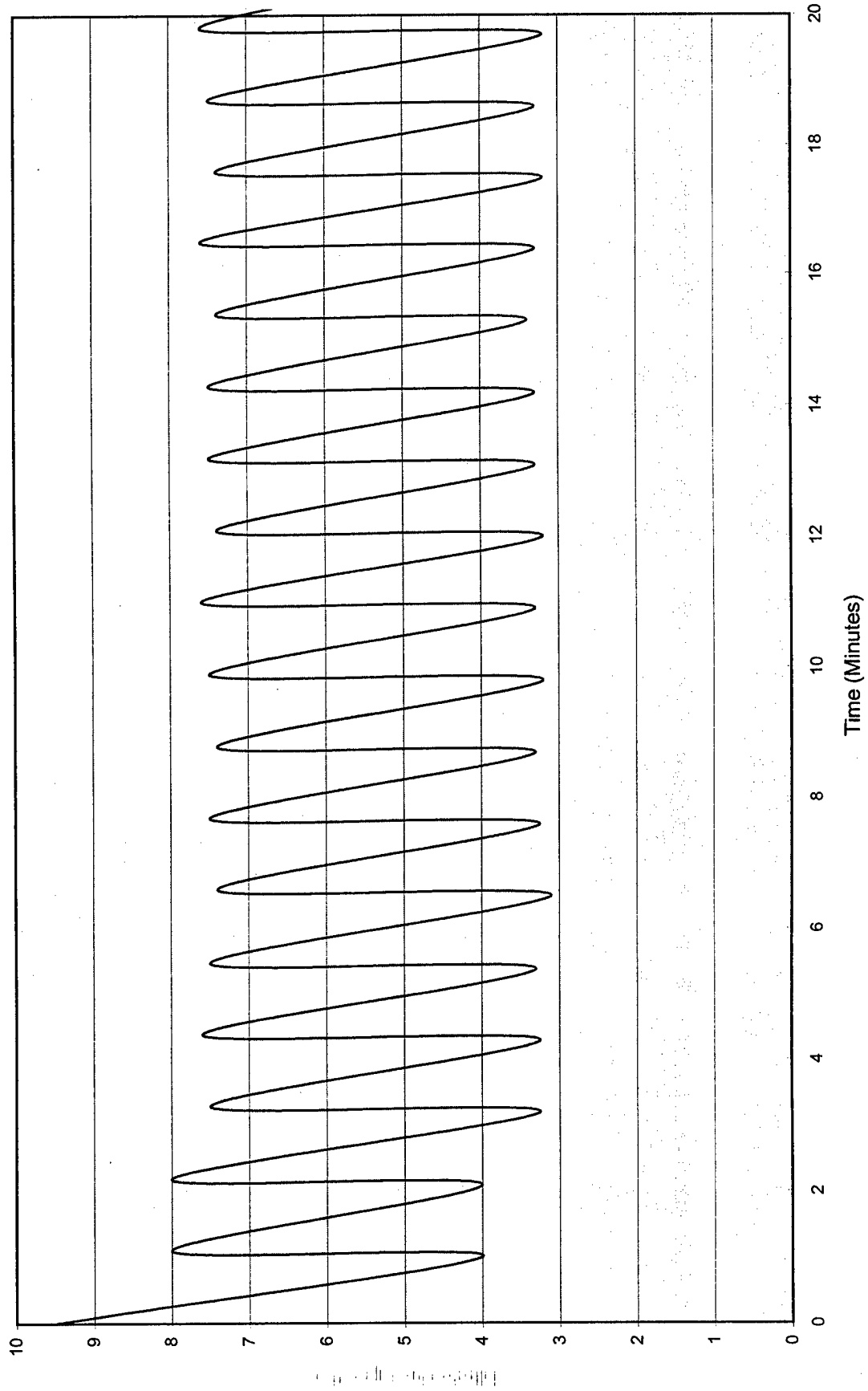

Figure D-1: Effect of Back-Flush on Filtrate Flux (1000 ppm Contamination)

Membrane: 3  $\mu$ m, SS 316L Sintered Fiber of Bekaert  
Trans-Membrane Pressure: 26 psi  
Back-Flush Cycle: 10 seconds / 1 minute

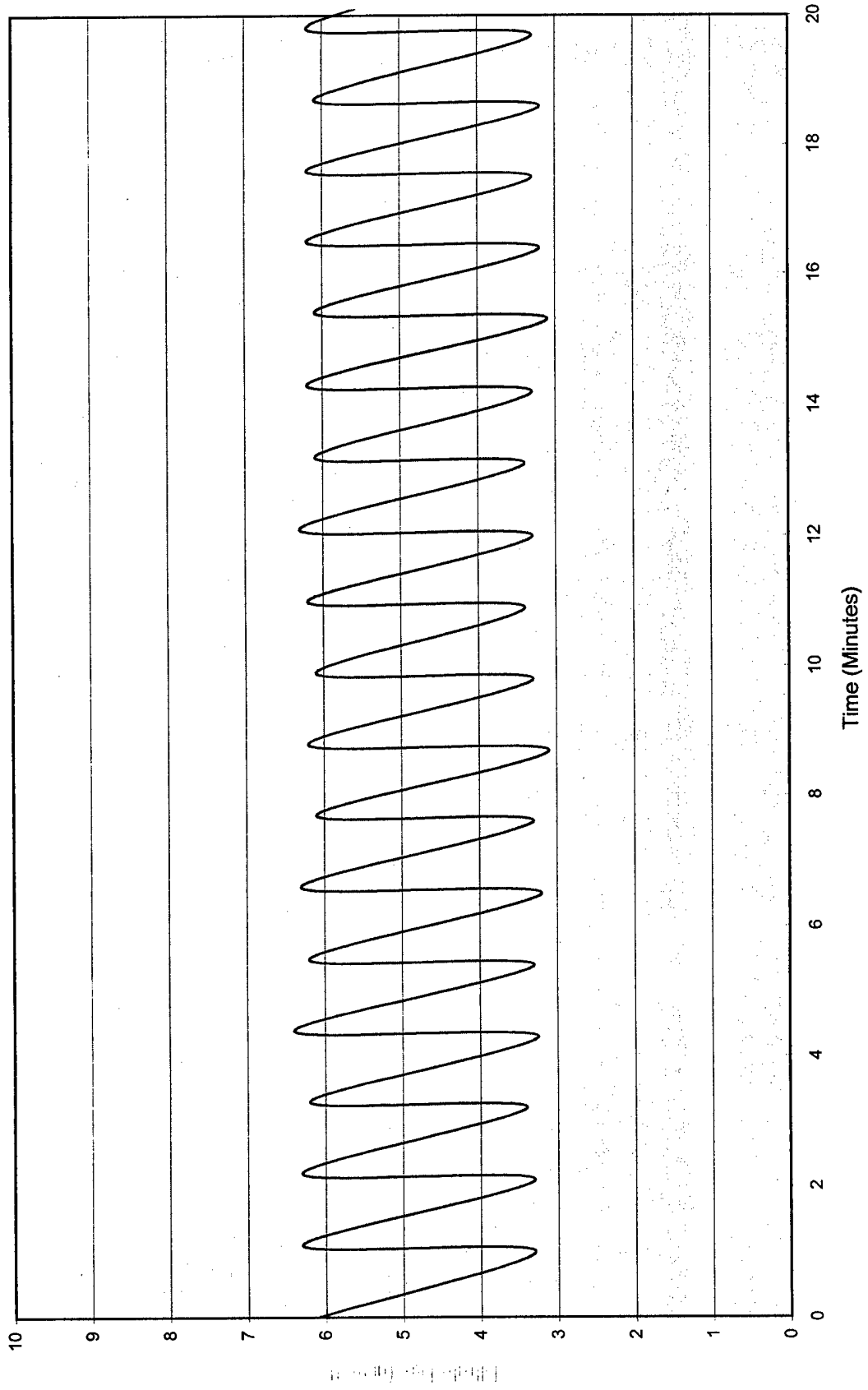

Figure D-2: Effect of Back-Flush on Filtrate Flux (2000 ppm Contamination)

Membrane: 3  $\mu\text{m}$ , SS 316L Sintered Fiber of Bekaert  
Trans-Membrane Pressure: 26 psi  
Back-Flush Cycle: 10 seconds / 5 minute

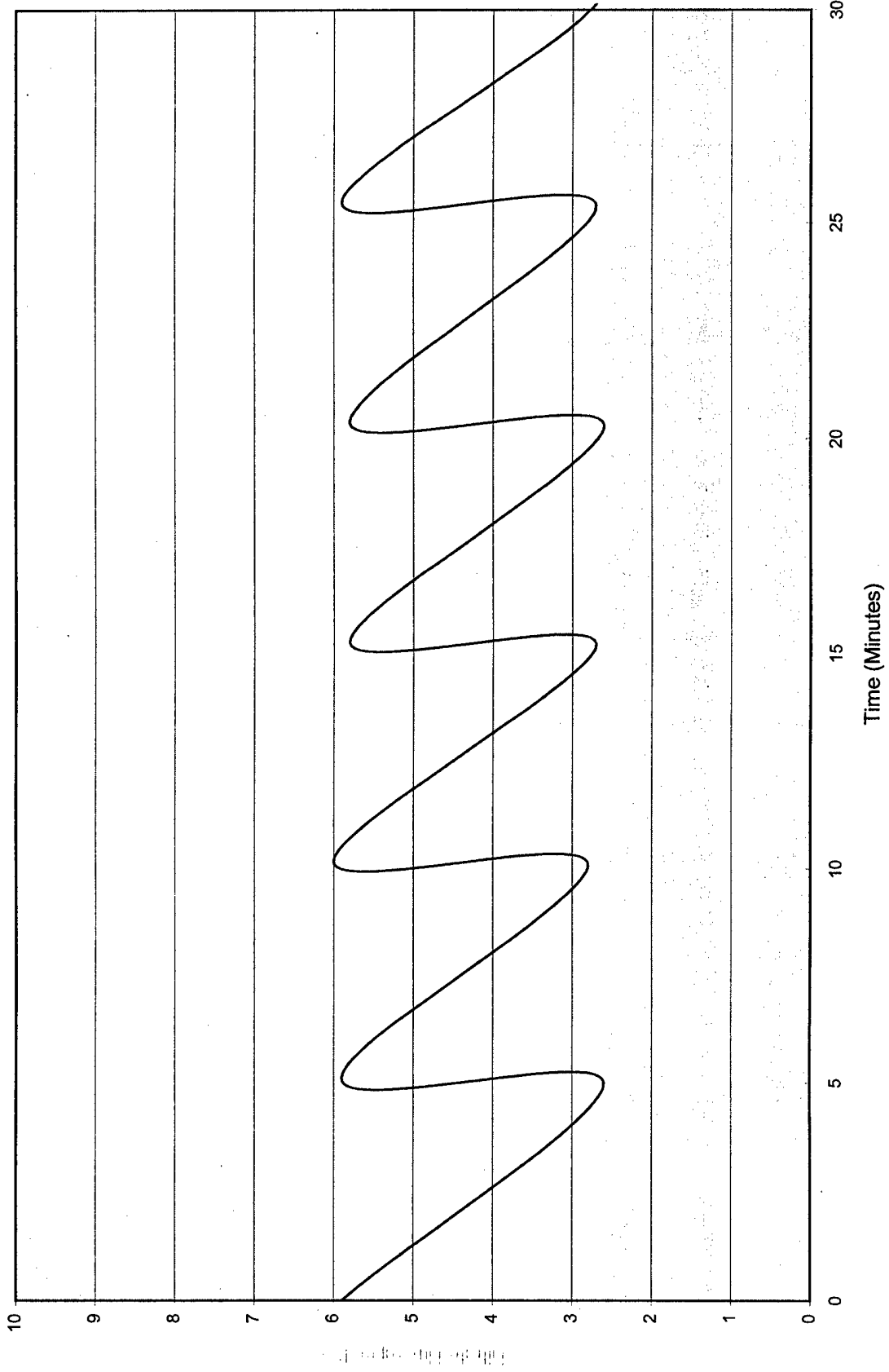

Figure D-3: Effect of Back-Flush on Filtrate Flux (2000 PPM Contamination, 10sec/5min Back-Flush Cycles)

Membrane: 3  $\mu\text{m}$ , Bekaert, SS 316L Sintered Fiber  
Trans-Membrane Pressure: 23 psi  
Back-Flush Cycle: 10 seconds / 1 minute

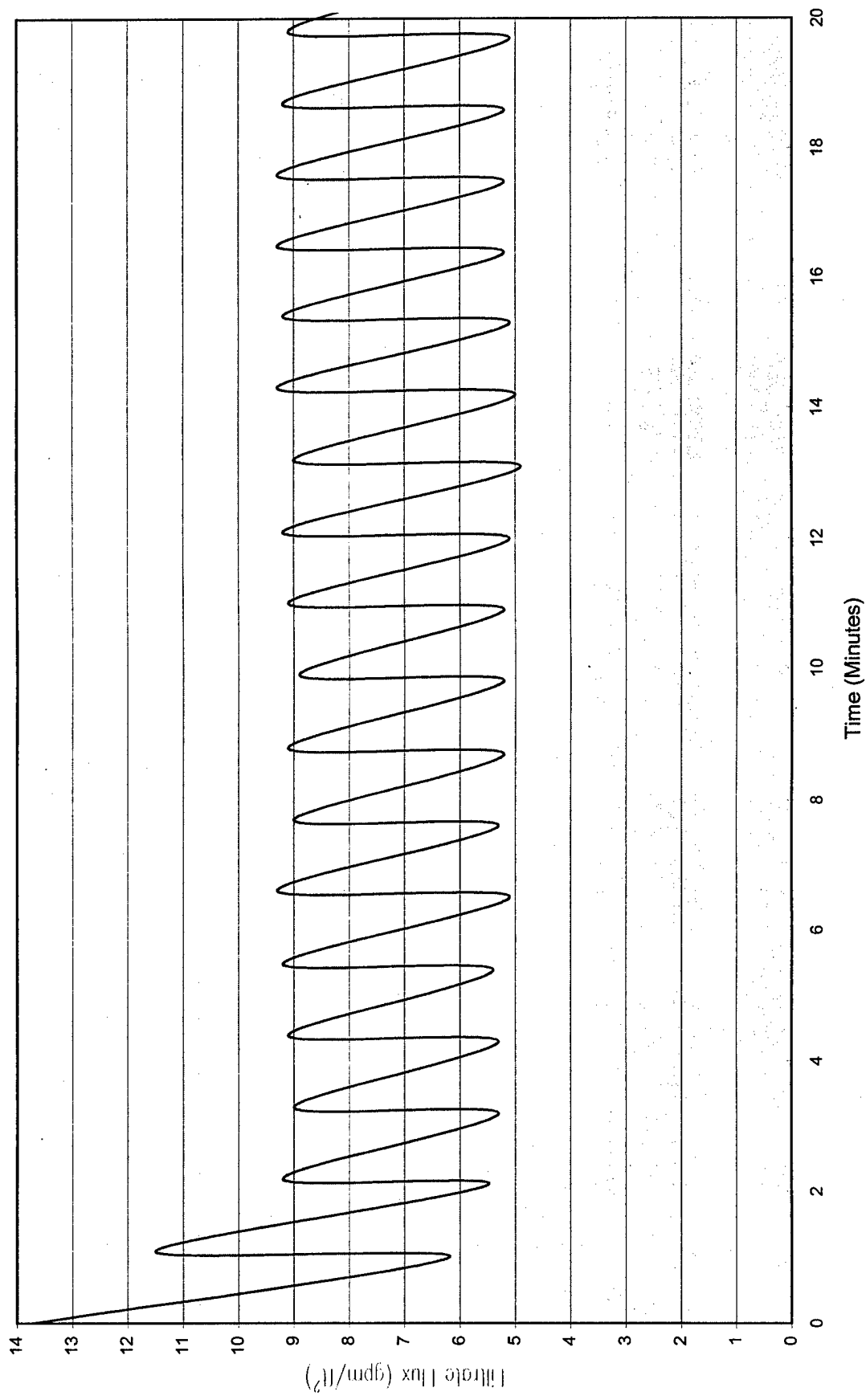

Figure D-4: Effect of Back-Flush on Filtrate Flux (1000 PPM Contamination)

Membrane: 3  $\mu\text{m}$ , Bekaert, SS 316L Sintered Fiber  
Trans-Membrane Pressure: 23 psi  
Back-Flush Cycle: 10 seconds / 3 minute

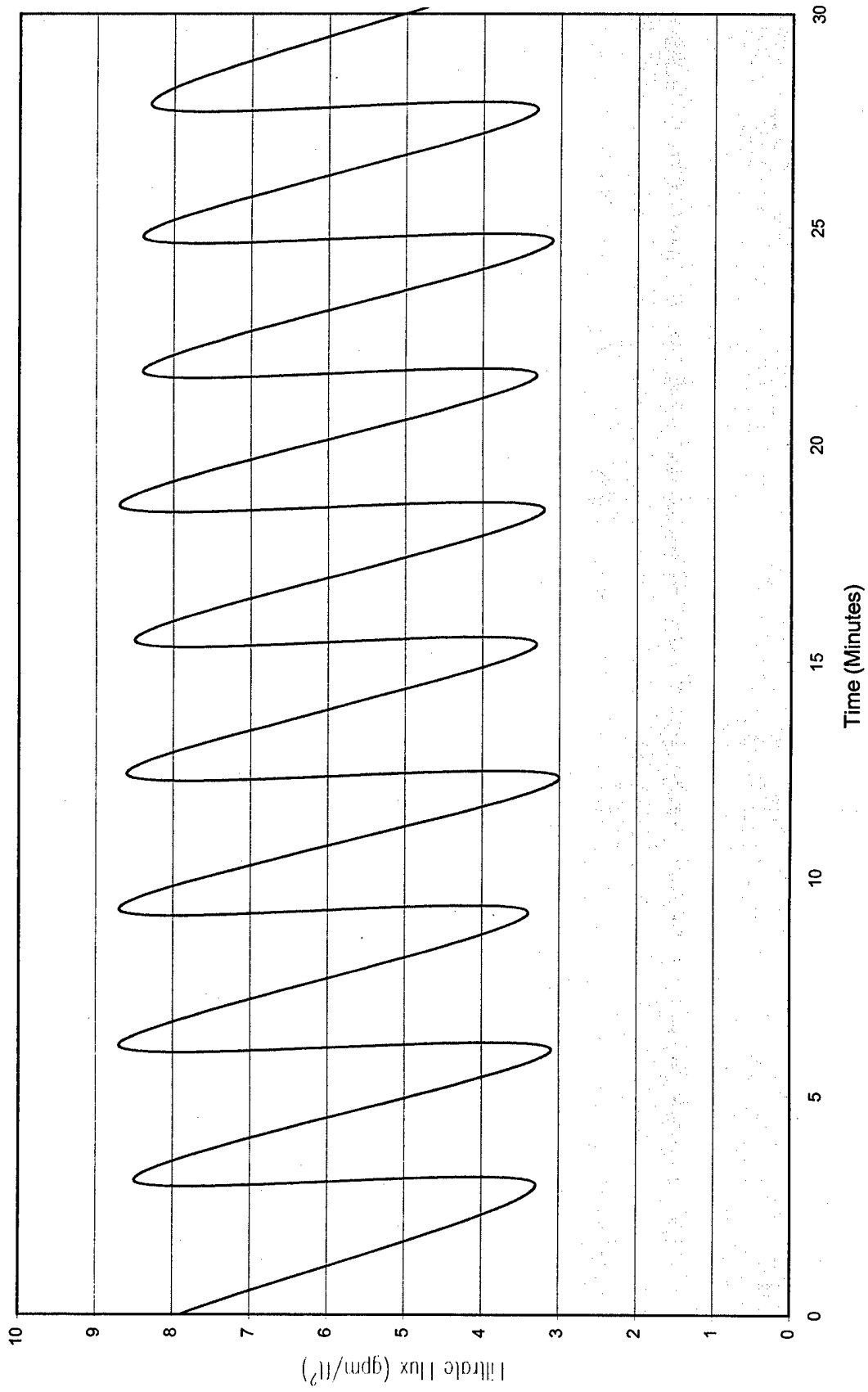

Figure D-5: Effect of Back-Flush on Filtrate Flux (1000 PPM Contamination)

Membrane: 3  $\mu\text{m}$ , Bekaert, SS 316L Sintered Fiber  
Trans-Membrane Pressure: 23 psi  
Back-Flush Cycle: 10 seconds / 10 minute

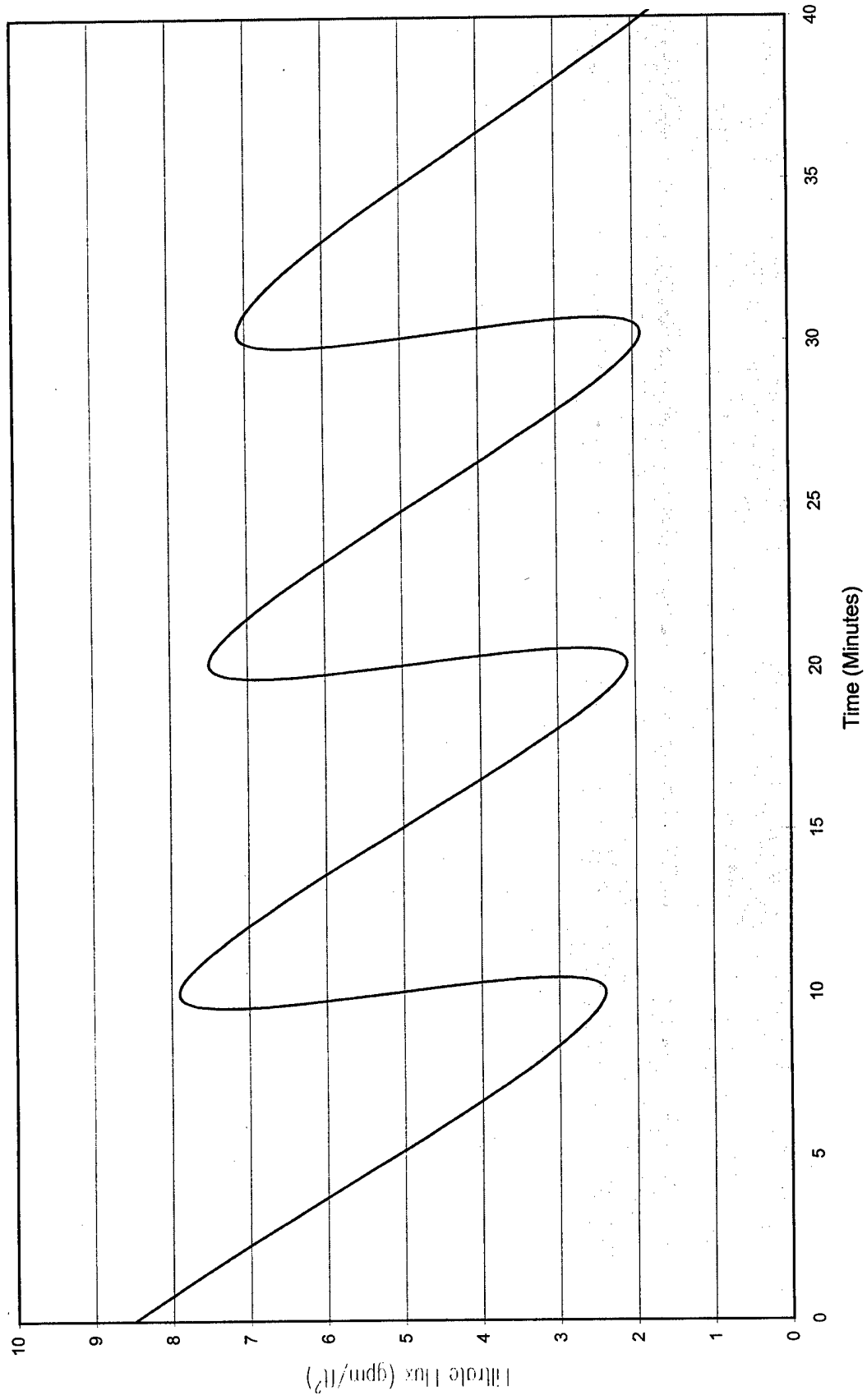

Figure D-6: Effect of Back-Flush on Filtrate Flux (1000 PPM Contamination)