

NAVAL POSTGRADUATE SCHOOL Monterey, California



THESIS

INVERSION OF SHALLOW WATER BOTTOM
SEDIMENT PROPERTIES USING AN/SQS-53C
REVERBERATION LEVEL DATA FROM EXERCISE
LWAD 99-1

by

David A. Schalm

September 1999

Thesis Advisors:

Robert H. Bourke
James H. Wilson

Approved for public release; distribution is unlimited.

DTIC QUALITY INSPECTED 2

19991227 028

REPORT DOCUMENTATION PAGE

Form Approved
OMB No. 0704-0188

Public reporting burden for this collection of information is estimated to average 1 hour per response, including the time for reviewing instruction, searching existing data sources, gathering and maintaining the data needed, and completing and reviewing the collection of information. Send comments regarding this burden estimate or any other aspect of this collection of information, including suggestions for reducing this burden, to Washington headquarters Services, Directorate for Information Operations and Reports, 1215 Jefferson Davis Highway, Suite 1204, Arlington, VA 22202-4302, and to the Office of Management and Budget, Paperwork Reduction Project (0704-0188) Washington DC 20503.

1. AGENCY USE ONLY (Leave blank)

2. REPORT DATE
September 1999

3. REPORT TYPE AND DATES COVERED
Master's Thesis

4. TITLE AND SUBTITLE
INVERSION OF SHALLOW WATER BOTTOM SEDIMENT PROPERTIES USING
AN/SQS-53C REVERBERATION LEVEL DATA FROM EXERCISE LWAD 99-1

5. FUNDING NUMBERS
N660499WR90135

6. AUTHOR(S)
Schalm, David A.

7. PERFORMING ORGANIZATION NAME(S) AND ADDRESS(ES)
Naval Postgraduate School
Monterey, CA 93943-5000

8. PERFORMING
ORGANIZATION REPORT
NUMBER

9. SPONSORING / MONITORING AGENCY NAME(S) AND ADDRESS(ES)
Naval Undersea Warfare Center - Newport Division
176 Howell Street
Newport, RI 02841-1708

10. SPONSORING /
MONITORING
AGENCY REPORT NUMBER

11. SUPPLEMENTARY NOTES

The views expressed in this thesis are those of the author and do not reflect the official policy or position of the Department of Defense or the U.S. Government.

12a. DISTRIBUTION / AVAILABILITY STATEMENT

Approved for public release; distribution unlimited.

12b. DISTRIBUTION CODE

13. ABSTRACT

Inversion techniques are used to infer bottom sedimentary characteristics using AN/SQS-53C Reverberation Level (RL) data gathered during Exercise LWAD 99-1. Analysis was conducted to determine the correlation between sediment type and beam RL time series statistics, including slope and detrended higher order statistics (standard deviation, skew, and kurtosis). A geographic contour plot of the spatial distribution of sediments was generated from the deviation of the RL slope of individual beamform data from the area-wide average RL slope. The resulting plot shows features similar to that of the pre-exercise sedimentary characterization map. Higher order statistics are found to be non-Gaussian which has signal processing implications.

14. SUBJECT TERMS

Acoustics, Bottom Scattering Strength, Geo-acoustics, Reverberation, Inversion Techniques, AN/SQS-53C Active Sonar Performance, LWAD

15. NUMBER OF
PAGES
121

16. PRICE CODE

17. SECURITY CLASSIFICATION OF
REPORT
Unclassified

18. SECURITY CLASSIFICATION OF
THIS PAGE
Unclassified

19. SECURITY CLASSIFI- CATION
OF ABSTRACT
Unclassified

20. LIMITATION
OF ABSTRACT
UL

NSN 7540-01-280-5500

Standard Form 298 (Rev. 2-89)
Prescribed by ANSI Std. Z39-18

Approved for public release; distribution is unlimited

**INVERSION OF SHALLOW WATER BOTTOM SEDIMENT PROPERTIES USING
AN/SQS-53C REVERBERATION LEVEL DATA FROM EXERCISE LWAD 99-1**

David A. Schalm
Lieutenant, United States Navy
B.S., United States Naval Academy, 1991

Submitted in partial fulfillment of the
requirements for the degree of

MASTER OF SCIENCE IN PHYSICAL OCEANOGRAPHY

from the

NAVAL POSTGRADUATE SCHOOL

September, 1999

Author: David A. Schalm
David A. Schalm

Approved by: Robert H. Bourke
Robert H. Bourke, Thesis Advisor

James H. Wilson
James H. Wilson, Thesis Advisor

Roland W. Garwood Jr.
Roland W. Garwood Jr., Chairman
Oceanography Department

ABSTRACT

Inversion techniques are used to infer bottom sedimentary characteristics using AN/SQS-53C Reverberation Level (RL) data gathered during Exercise LWAD 99-1. Analysis was conducted to determine the correlation between sediment type and beam RL time series statistics, including slope and detrended higher order statistics (standard deviation, skew, and kurtosis). A geographic contour plot of the spatial distribution of sediments was generated from the deviation of the RL slope of individual beamform data from the area-wide average RL slope. The resulting plot shows features similar to that of the pre-exercise sedimentary characterization map. Higher order statistics are found to be non-Gaussian which has signal processing implications.

TABLE OF CONTENTS

I. INTRODUCTION.....	1
A. OBJECTIVE	1
B. SHALLOW WATER ASW PROBLEM.....	2
C. REVERBERATION.....	3
D. BOTTOM BACKSCATTERING.....	4
E. INVERSION TECHNIQUES.....	5
F. EXERCISE LWAD 99-1.....	6
1. Geo-Acoustics of the South Florida Platform.....	7
2. Event Weather and Oceanography.....	9
3. Bottom Backscattering Measurements.....	10
II. TREATMENT OF DATA.....	15
A. DESCRIPTION OF LWAD 99-1 REVERBERATION DATA.....	15
B. HYPOTHESIS.....	16
C. PROCESSING METHOD.....	18
1. Example Using Slope Data, SD-Mode, 1/0.75 Moving Statistics.....	19
III. ANALYSIS.....	21
A. ANALYSIS OF RL SLOPE DATA.....	21
1. SD-Mode.....	21
2. VD-Mode.....	23
B. HOS ANALYSIS.....	24

C. DISCUSSION	26
1. Tactical Implications of Sediment Map	26
2. Tactical Significance of Non-Gaussian HOS	26
IV. CONCLUSIONS AND RECOMMENDATIONS.....	31
APPENDIX A. FIGURES	33
APPENDIX B. MATLAB FILES	65
LIST OF REFERENCES	107
INITIAL DISTRIBUTION LIST	111

I. INTRODUCTION

A. OBJECTIVE

The objective of this thesis is to develop a real time, high-resolution method for determining bottom sediment acoustic properties in a shallow water environment. This study sought to determine those properties through the analysis of the slope characteristics of beam reverberation data and higher order statistics (HOS) related to the RL beam time series.

Current fleet anti-submarine warfare (ASW) operations are limited in shallow water in part because of their dependence on bottom sediment type maps that are based on large area averages (low resolution) derived from few samples [Ref. 1]. Such maps provide limited or no information on the bottom roughness or the sediment composition beneath the water-sediment interface. They further limit the accuracy of ASW operations because of the high spatial variability of the sedimentary composition, both laterally and vertically, that is a common feature of shallow water continental shelf areas.

This thesis examines the possibility of using inversion techniques to deduce sedimentary properties from beam reverberation level (RL) data. The use of RL data is practical not only because a large amount of data is

available for research, but because the RL data is gathered by active fleet assets rather than an oceanographic research vessel. In this study, the RL data was gathered during the Littoral Warfare Advanced Development (LWAD) Exercise 99-1, aboard a Ticonderoga class cruiser, using the AN/SQS-53C tactical sonar.

B. SHALLOW WATER ASW PROBLEM

Since the end of the cold war, anti-submarine warfare (ASW) operations have moved geographically from the deep, open ocean environment, to the nearshore, shallow water, littoral environment. Cold war ASW operations had their primary emphasis on locating and tracking Soviet ballistic missile submarines (SSBN) on patrol in the open ocean. Over the last 10 years, significant geo-political events have occurred which have shifted ASW emphasis to the littoral environment. With the downfall of the Soviet Union came a significant decrease in their SSBN patrols, while concurrently new threats arose in such places as the Middle East and the Korean peninsula. Smaller countries looked to acquire diesel-powered submarines for coastal defense. These vessels have become relatively affordable causing their numbers and countries of ownership to proliferate. The U.S. Navy ASW doctrine has responded to this paradigm change by placing increased emphasis on shallow water operations [Ref. 2].

Shallow water ASW operations are significantly more challenging than those conducted in the deep, open ocean. The littoral environment includes ocean fronts and eddies, stronger currents, extensive, often steep topographic changes, increased sea life, varied bottom sediment distributions, and increased shipping traffic. These factors combine to create a challenging ASW environment.

C. REVERBERATION

One of the most significant factors contributing to the complexity of shallow water ASW operations is the spatial variability of the sea bottom composition. The reflective nature of the overlying sediment exerts a significant effect on active sonar reverberation levels (RL). Reverberation is the sum of all random scattering mechanisms in the ocean [Ref. 3, p. 237]. In deep water (Figure 1) reverberation primarily exists as a combination of two scattering mechanisms, volume scattering and sea surface scattering. Volume scattering occurs due to scattering from marine life within the water column and from inhomogeneities in the ocean thermal/density structure. Sea surface scattering is due to random reflections (scattering) from a roughened air-ocean interface, and is a function of wind speed or wave height.

In shallow water (Figure 2) reverberation from the sea bottom typically dominates that due to volume or sea surface

reverberation. The contribution of bottom scattering to the total reverberation level (RL) is often so severe that a target echo that may have been detected in deep water can not be detected in shallow water (Figures 1 and 2).

D. BOTTOM BACKSCATTERING

Unlike RL, which is scattering in all azimuthal directions, backscattering is only that component of the scattered energy that returns to the receiver in monostatic (co-located transmitter/receiver) systems. The intensity of the backscattered energy from the sea floor that arrives at the sonar receiver is parameterized as the scattering strength, $S_b = 10 \log \frac{I_{scat}}{I_{inc}}$ [Ref. 3, pp. 238-239]. I_{scat} is the intensity of the scattered sound per unit area at a unit distance and I_{inc} is the incident plane wave intensity impinging on the scattering area. Measurements of RL and S_b , arising from sea bed backscattered energy, have indicated that S_b is a function of grazing angle (θ) and bottom type. Backscattering strength traditionally is represented using a Lambert's law relationship where $S_b = 10 \log \mu + 10 \log \sin^2(\theta)$. θ is the grazing angle and μ represents the degree of reflectivity of the sediment interface. Based on the deep water data of Mackenzie [Ref. 4] and others, Urlick [Ref. 3, pp. 271-273] reports that over

moderately rough topography of varying sedimentary makeup and small to intermediate grazing angles Mackenzie's constant ($k = 10 \log \mu$) averaged about -29 dB, being essentially invariant in frequency and grazing angle. More recently, shallow water experiments have indicated an association of Mackenzie's constant to the bottom sediment type and that the grazing angle dependence may be scaled as $\sin(\theta)$ over muddy, absorptive bottoms where volume reverberation from the upper layers of the sediment may be important [Ref. 5]. This finding suggests a direct correlation exists between backscattering strength and sediment type. With this knowledge, it is possible to use inverse techniques to infer the nature of the sediment type as a function of its reflectivity from RL data.

E. INVERSION TECHNIQUES

The "forward problem" in acoustics are those methods in which one predicts the characteristics of the acoustic propagation field from a knowledge of the governing oceanic parameters (e.g., sound speed structure, sea surface roughness, geo-acoustic properties, etc.) through which the sound is travelling. "Inverse" (or inversion) techniques are the exact opposite such that one infers one or more oceanic parameters through the analysis of acoustic propagation data. [Ref. 6]

Inverse techniques have a wide variety of applications including high resolution geo-acoustic modeling [Ref. 7] and simulation of broadband signal propagation [Ref. 8].

Inversion techniques (IT) are used in this study to identify features in the beam reverberation time series from which bottom sedimentary properties can be deduced. RL features such as the slope of the RL time series and higher order statistics (HOS) describing the shape of the RL time series are analyzed to identify correlations to sediment type.

F. EXERCISE LWAD 99-1

The Littoral Warfare Advanced Development (LWAD) Exercise 99-1 was conducted from 8 to 15 February 1999 in the Gulf of Mexico approximately 200 km WNW of Key West, Florida, on the southwest Florida continental shelf (Figure 3). This test was the ninth in a series of exercises performed as part of the LWAD project, a program of shallow water exercises designed to identify new technologies which have a potential to be transitioned to fleet systems in the near future. The LWAD program efforts are concentrated on technologies that will aid in the location and classification of diesel-electric submarines and mines in a shallow water littoral environment. [Ref. 9]

LWAD 99-1 included several experiments, one of which was for the continued development of inversion techniques.

The inversion technique experiment had the following objectives: (1) record AN/SQS-53C data in a geographically variable environment and (2) collect ground truth information in order to test monostatic and bistatic inversion techniques [Ref. 10].

The data examined in this thesis was collected during event 31 conducted on 9 February 1999 from 0730Z to 1800Z at LWAD 99-1 site 1 (Figure 3). The USS Vicksburg ship's track during this event is shown in Figure 4; over 900 pings from the AN/SQS-53C tactical sonar were recorded during the event. Event 31 was conducted with a target present; the target track history is also shown in Figure 4.

1. Geo-Acoustics of the South Florida Platform

The LWAD 99-1 exercise area lies on the southwest portion of the continental shelf bordering the west coast of Florida. The shelf is composed of a karstic Miocene platform that is under Pliocene-Pleistocene and Holocene sediments [Ref. 11]. The composition of the surface sediment was analyzed by Holmes from a variety of sources including sediment core samples and seismic data. Figure 5 is a depiction of the surface sedimentary distribution at LWAD 99-1 site 1 based upon Holmes' analysis and represents the most definitive characterization of the upper ocean sediment composition prior to the commencement of LWAD 99-1.

Howell Hook reef, lying along the western portion of site 1 at a depth of 150 m is a natural border between the inner shelf and the shelf slope. Howell Hook is composed of coral reef material, while immediately to the east is a region of inter-reef sediments. The inner shelf, a region of recent sedimentary processes (depositional), contains a variety of surficial sediments and is characterized by a gentle slope of 0.07° . Farther eastward on the inner shelf is a region of foraminiferal sands with sandwaves common. Westward of Howell Hook the slope is approximately 0.2° and increases through a series of steps until the escarpment is reached with slopes as much as 45° [Ref. 12].

As part of the environmental characterization for Exercise LWAD 99-1, sediment samples were collected. However, the results were not available in time for inclusion in this study. Preliminary analysis indicates that Howell Hook is overlain by a layer of silty sand, while the inter-reef region is composed of a clay silt mixture. East of the inter-reef region the sediment is composed of fine to coarse grain sand particles [Ref. 13].

Based on the geo-acoustic modeling methods of Hamilton and Bachman [Ref. 14], a characterization of the reflective properties of the sediments can be accomplished. From Table 1, the mean grain size can be determined from a description

of the sediment type. Grain size can then be correlated to porosity and saturated bulk density as illustrated in Figures 6 and 7. Porosity, which is a measure of the amount of voids occupied by water in a material, can then be used to determine the compressional wave speed of the sediment (Figure 8). The characteristic impedance, the product of the sediment density and wave speed, is an indicator of the reflective nature of a particular sediment composition.

The geo-acoustic method described above indicates that the degree of reflectivity can be determined from the sediment type. In particular, reflectivity is proportional to grain size. It is anticipated, therefore, that the region on the eastern side of site 1 should be the most reflective and should have higher reverberation levels. The Howell Hook region should be less reflective, but still more reflective than the inter-reef region which should be the least reflective and have correspondingly lower reverberation levels.

2. Event Weather and Oceanography

All acoustically relevant meteorological and oceanographic parameters were essentially invariant during the 12-hour duration of event 31, making for near-laboratory conditions. The sky was free of clouds with wind speeds less than 5 m/s. The sea surface was calm with a significant wave height of 0.5-0.7 m. The surface current

measured during the event averaged around 0.25 m/s in a northerly direction. [Ref. 15]

A total of 23 CTD observations were taken throughout site 1 between 6 - 9 February. Figure 9 shows the sound speed profiles (SSP) calculated from the CTD observations. Little spatial or temporal variability between the profiles is observed (< 1 m/s), reflective of the near constant oceanic-atmospheric forcing. The mixed layer is seen to oscillate between 18 - 25 m. The downward refracting nature of the SSP ensures strong bottom interactions of the acoustic signal. [Ref. 15]

3. Bottom Backscattering Measurements

Bottom backscattering measurements taken with a vertical array during LWAD 99-1 [Ref. 16] indicated that the bottom scattering strength (S_b) exhibited a $\sin(\theta)$ dependence, not the $\sin^2(\theta)$ dependence of Lambert's Law. Previous results obtained from a shallow water area south of Long Island [Ref. 5] established a $\sin(\theta)$ bottom scattering strength relationship with a silty clay bottom having a surface sediment compressional wave speed of less than 1600 m/s. Over sandy bottoms S_b suggested a $\sin^2(\theta)$ dependence in agreement with Lambert's Law.

It is common practice to make backscattering measurements in just one location and then extend those

results to a wider area [Ref. 12], but this practice can be misleading. The spatial distribution of sediments in shallow water is generally highly variable over short spatial scale lengths. Scanlon et al. [Ref. 5] showed that the spatial scale can grade from hard sand to mud/silt clay sediments over distances less than 500 m.

In this thesis, a bottom sediment map is constructed based upon spatially-varying changes in the beam reverberation data from an AN/SQS-53C tactical active sonar. While the results are considered preliminary due to a lack of high resolution bottom samples, they do indicate a high degree of spatial variability of sediment types that, only on the average, agree with the pre-exercise wide-area sediment assessment [Ref. 12]. It will be instructive to compare the results of the frequent sediment grab samples taken during LWAD 99-1 with the results of this thesis. A conclusion that can be stated now is:

Single point bottom backscattering measurements can not predict the high spatial sediment variability and inverse techniques must be developed to estimate this variability.

Another limitation of bottom backscattering analysis is the assumption that the scattering occurs at the sediment-water interface. Recent studies [Ref. 17] show that the scattering occurs from inhomogeneities in the sediment sub-bottom for slow (i.e., clay, mud) sediments at low grazing

angles (Figure 10). Therefore, a full wave model with an accurate three-dimensional model of the sub-bottom geoacoustic properties must be used to estimate TL in shallow water. Just a few years ago it did not seem possible to run a full wave model at 3500 Hz, but with today's computing power, it is feasible. Within a few years it will be commonplace to run these full wave models in near real time and the real time IT sediment-mapping algorithm developed here is intended for this future application.

Sediment type	No. samples	Mean grain size		Sand, %	Silt, %	Clay, %	Bulk grain density g/cm ³
		mm	phi size				
Sand							
Coarse	2	0.5285	0.92	100.0	0.0	0.0	2.710
Fine	28	0.1638	2.61	92.2	4.1	3.7	2.709
Very Fine	16	0.0988	3.34	81.0	12.5	6.5	2.680
Silty Sand	40	0.0529	4.24	57.0	30.9	12.1	2.677
Sandy Silt	47	0.0340	4.88	30.3	57.8	11.9	2.664
Silt	19	0.0237	5.40	7.8	80.1	12.1	2.661
Sand-silt-clay	29	0.0177	5.82	31.7	42.9	25.4	2.689
Clayey silt	105	0.0071	7.13	7.4	58.3	34.3	2.656
Silty clay	54	0.0022	8.80	3.9	34.8	61.3	2.715

Table 1. Continental terrace (shelf and slope) environment; Average sediment size analyses and bulk grain densities. From Ref. [14].

THIS PAGE INTENTIONALLY LEFT BLANK

II. TREATMENT OF DATA

A. DESCRIPTION OF LWAD 99-1 REVERBERATION DATA

The beam reverberation data used in this study was collected using the AN/SQS-53C fleet tactical sonar aboard the USS Vicksburg, during event 31 of exercise LWAD 99-1 on 9 February 1999 [Ref. 10]. Beam reverberation data were analyzed from two modes of operation of the AN/SQS-53C, the SD (surface duct) and VD (variable depression) modes. For consistency, all pings that were analyzed used either a linear phase modulated pulse or a CP (coded pulse) waveform.

The SD-mode uses a 300 millisecond pulse length and has a 360° azimuthal transmit coverage employing 72 receive beams. The VD-mode uses a 500 millisecond pulse length and has a 120° azimuthal transmit coverage employing 24 receive beams. In both modes, the 3-dB beamwidth is 5 degrees. The frequency range is from 2400 to 4500 Hz. The depression angle was 3°, while the range scale was set to 20 kyds.

Event 31 was conducted such that the VD-mode pings were directed toward the center of the CG box. This was done to get complete coverage of the box and have RL information about the same geographic location from different directions. When the CG was traversing the western portion of the box, on a course of 000°T, the sonar center section

true bearing was 090°T (Figure 11); during the northern leg (course 090°T) the sonar center section true bearing was 180°T (Figure 12), etc. The center section true bearing for the VD-mode is the bearing between beams 12 and 13.

All SD-mode pings (omni-directional) had a center section true bearing of 180°T. The center section true bearing for the SD-mode is the bearing between beams 36 and 37. Beam 1 would therefore cover from 000°T to 005°T, beam 2 from 005°T to 010°T, etc. Beam 72 would cover bearings 355°T to 360°T.

B. HYPOTHESIS

Reverberation is a combination of backscattered energy from within the water column (volume), the sea surface and the sea floor. For this study it is assumed that the volume and sea surface components of reverberation were constant. Therefore, it is hypothesized that for a single ping from the AN/SQS-53C different RL beam (bearing) time series should only differ because of variations in backscattered energy from differing bottom types. This hypothesis is further extended to encompass a set of pings (as many as 41 pings were used in one data set), as long as they occur in the same general area and there are no changes to the ping type.

The following assumptions were made to support this hypothesis:

(1) The sound speed profile in the area around the source (within ~20 kyds) is constant.

- As seen in Figure 9, there is little spatial or temporal variability of the sound speed profile.

(2) The output source level (SL) from the AN/SQS-53C in any direction does not vary (i.e., the AN/SQS-53C SL is independent in azimuth).

- The difference in performance of the AN/SQS-53C in any direction is considered negligible for this experiment. Analysis of individual RL time series, though, indicates that within 45° of the CG stern an increase in ambient (background) noise (AN) due to own ship noise is observed (Figures 13 and 14). This phenomenon was accounted for in the processing of the RL data.

(3) There are no major topographic changes that would significantly change the RL curve (i.e., no upslope/downslope effects, no pinnacles, etc.)

- Based on the geologic characterization, there were no bottom topography features that would significantly effect the received reverberation levels.

C. PROCESSING METHOD

An example of how the sediment effects reverberation can be seen by comparing two different RL time series in which distinctly different characteristics can be seen. Figure 13 is a single beam (beam 17) RL time series bearing 082.5°T. One sees that the RL curve reduces to the background noise level at around 18 s where the AN level at 3.5 kHz is approximately 35 dB. In contrast, Figure 15 (beam 37, bearing 182.5°T) shows an example with the same AN level, for which the RL curve does not reach the AN level until about 23.5 s. Clearly the beam data is RL-limited longer in Figure 15. It is suggested that this heightened RL is due to the presence of a more reflective bottom. The relationship between RL and AN as a function of detection range is illustrated in Urick [Ref. 3, Figure 2.2].

The general method proposed for RL curve analysis is as follows: (1) determine a characteristic RL curve for an area determined from the average of many pings and (2) compare individual beam data to determine its difference from the area-wide mean.

A variety of statistical parameters derived from the beam RL time series can be examined to determine if the characteristics of the RL curve bear any correlation to sediment type. The statistical parameters investigated

include the mean slope, standard deviation, skew, and excess kurtosis.

Before continuing, some background about the statistical method used in this thesis is required. The statistics calculated are not based on the entire time series but rather from segments of the time series partitioned into 0.5, 1, or 2 second increments. In addition, a degree of overlap of the data is often useful, e.g., 0.25, 0.5, 0.75 (or 25/50/75% of the interval). The statistics derived from the overlapped segments are referred to as "moving" statistics (moving average, moving skew, etc.). For example, a 25-second time series, with 320 data points per second, contains 8000 data points. With an interval/overlap combination of 1/0.75 the first data point of the moving mean would be the mean of points 1 to 320, the second point would be the mean of points 81 to 400, the third would be the mean of points 161 to 480, etc. Figure 16 shows an individual RL time series (black) overlaid by the 1/0.75 moving mean (white) RL curve.

1. Example Using Slope Data, SD-Mode, 1/0.75 Moving Statistics

From a data set of 41 pings an area-wide average slope is calculated by first taking the 1/0.75 moving mean for all of the beams (72) in each transmitted ping. The slope of each beam is determined by calculating the gradient (d/dt) of the mean RL curve. Calculating the mean from all (72x41)

slope data sets generates the area-wide average slope data. The area-wide average RL slope for all the pings examined is comprised of over 2500 individual RL slope time series. Figure 17 shows the area-wide average (solid line) RL slope and its standard deviation (--).

Figure 17 also shows the beam slope for a particular beam/ping relative to the area-wide average slope. Each point along the single beam slope has an associated range and bearing which corresponds to a geographic position. By determining the difference between the area-wide average slope and the individual beam slope, a geographic contour plot can be generated to display the anomaly from the mean (Figure 18). Subsequently, different pings can be compared to determine if any geographic correlation exists between sets of pings to identify a unique but consistent area exhibiting similar RL characteristics.

The other statistical parameters (STD, skew, and excess kurtosis) can be analyzed using an identical method to that used for the slope.

III. ANALYSIS

A. ANALYSIS OF RL SLOPE DATA

1. SD-Mode

A thorough analysis of all the RL slope plots was conducted to create a geographic representation of sediment type based on consistent spatial variations in the RL slopes. From a continuous sequence of 41 SD-mode pings a contour plot was created based on the deviations of the individual RL slopes from the area-wide average.

Through the analysis of the slope data and comparisons to that from different pings, RL slope features can be seen that are consistent in their geographic location. The RL curves from ping 34 exhibit slope characteristics that are common in all pings in the set and will be discussed in detail. Figure 18 is a geographic contour plot of the deviations of each of the 72 azimuthal beams of ping 34 RL slope from the area-wide average RL slope. It is anticipated that regions where the deviations (from the average RL slope) are positive correspond to more reflective areas, while regions with a negative deviation are less reflective. For example, Figure 19 shows the RL and slope data of ping 34, beam 22. At approximately 8.5 s a region of increased RL is observed with a corresponding increase in RL slope. Figure 20 depicts the region of beam 22 enlarged

to show the RL slope details. The same geographic region of increased RL can be seen on contour plots of different pings (Figures 21 - 23). Note that the RL slope anomaly seen here is consistent in its geographic location indicating that it is due to a geographic feature, and not to a random occurrence.

Figure 24 is similar to that of Figure 18 but is derived from a composite plot of all 41 SD-mode pings. It is the average deviation of RL slope from the area-wide average RL slope at each geographic location. Being an average of the RL slope deviations, this plot will show RL slope features that have geographic consistency, while eliminating those features that are not geographically consistent. Note that the area within $\pm 45^\circ$ of the CG stern were not included in the composite map and accounts for the notches, especially to the west, seen in the figure.

An analysis of Figure 24 shows clear similarities to the pre-exercise sedimentary characterization (Figure 5). There are 3 distinct geographic locations observed in Figure 24; east of 84.05°W is the foraminiferal sands area, Howell Hook is west of 84.3°W and the middle is the inter-reef area which is interspersed with low and high reflective zones. The highly reflective zones could be uncovered (or thinly covered) reef segments whereas the less reflective spots may

be due to depressions/basins filled with unconsolidated sediments. It is notable that the foraminiferal sands and Howell Hook regions are relatively uniform, while the inter-reef region shows high spatial variability of sediment types.

2. VD-Mode

Due to the limited data available the VD-mode data were not used to create a composite map of the exercise area. However, individual pings were analyzed to see if there were any geographically consistent RL slope features as determined from the analysis of the SD-mode data.

Due to the nature of the exercise the VD-mode pings were directed towards the center of the CG box. This was done to obtain full coverage of the area within the box but unfortunately created limitations for this study. In particular, sedimentary features such as Howell Hook and the foraminiferal sands region, which were beyond the boundaries of the exercise box, would not be visible on the RL plots.

The VD-mode pings did, however, demonstrate similar geographically consistent features as seen in the SD-mode. Figures 25 and 26 are individual VD-mode pings from which geographic features can be seen. Note that the high and low bottom reflection areas observed in Figures 25 and 26 are also seen at the same location in the SD-mode composite plot (Figure 24).

B. HOS ANALYSIS

The same analysis methods used on the RL slope data were employed to identify the correlation of HOS to sediment type. Figures 27-29 are plots of RL and the corresponding STD, skew, and excess kurtosis. The RL STD and skew plots show deviations that can be correlated to RL features. The RL kurtosis deviations, however, appeared random and showed no apparent correlation to sediment type. The observed RL STD and skew features are marginally useful in that they only provide an inference that some sedimentary change is present. They do not provide information about the characteristics of that feature (i.e., whether or not it is due to a more or less reflective sediment).

In order to further investigate RL statistics, a distribution analysis was conducted. Figure 30 is a plot of skew versus excess kurtosis for the detrended RL beam data of ping 189. The skew and excess kurtosis data shown are highly correlated with negative skew (characterized by an extended low amplitude tail compared to a Gaussian curve) correlated to positive excess kurtosis (characterized by a peaked distribution with more data centered around the mean compared to a Gaussian distribution). Preliminary distribution analysis indicates that the reverberation data is not only non-Gaussian, but the data spans several distribution types [Ref. 18].

It is important to note that statistical properties of the detrended beam time series are not commonly analyzed in classical detection theory applications. Instead, the output of a replica correlator is normally the input to a statistical analysis, and normalizations, such as whitened matched filters, etc., attempt to remove the amplitude decay, or slope, of the beam reverberation time series from the analysis [Ref. 18]. In this thesis we have taken a quite different approach by using the beam time series slope to invert bottom properties with the HOS of the detrended time series as derived product. If the thesis objective were focused on detection performance, we could have done a replica correlation analysis of the residual, or detrended beam time series. Instead, we are simply trying to correlate the HOS of the detrended time series to the environment. Since little is known about the HOS of the detrended beam time series, we are just reporting that they were highly non-Gaussian and further investigation concerning their distribution function is needed. Although the HOS did not correlate well with sediment type, this does not imply that they will not correlate with some other environmental parameter, such as water depth or sound speed profile.

C. DISCUSSION

1. Tactical Implications of Sediment Map

The high variability of bottom sediment type in shallow water exerts a strong tactical significance because it can unexpectedly affect, often times adversely, the results of an acoustic search which is executed under the assumption that the bottom sediment is homogenous. Figure 31(A) is indicative of a search plan that was executed assuming that detection ranges were constant (regardless of sediment type). This "mowing the lawn" technique could result in a lower probability of detection (PD) than anticipated due to regions where detection ranges are degraded because of a less reflective bottom. Prior to an acoustic search an environmental update could be conducted which includes an RL survey from which a sediment map, similar to the one in Figure 24, could be used to modify the search plan. "Searching by sediments", as seen in Figure 31(B), would account for detection range differences due to the bottom sediment type. In this case, the acoustic search would be executed under the appropriate, spatially-varying PD.

2. Tactical Significance of Non-Gaussian HOS

The analysis of the detrended beam reverberation data indicated that the backscattered energy is non-Gaussian, i.e., the values of skew and excess kurtosis are non-zero, and this also has important tactical implications. The

signal processing design incorporated into the AN/SQS-53C and other sonar systems is based on the assumption that the RL distribution is Gaussian. Challenging the Gaussian assumption raises two important questions:

(1) Is the non-Gaussian nature of the beam reverberation HOS due to environmental effects (e.g., shallow water acoustic propagation) or because of sonar signal processing design?

(2) If the RL HOS are due to the environment, will the HOS change when calculated for a different environment (e.g., deep water, continental slope or soft, muddy bottoms)?

The first question could be answered by performing the same statistical analysis of AN/SQS-53C RL data but taken from another environment. If the HOS are similar in varied environments, the nature of the HOS is probably due to the signal processing equipment. In this case, the non-Gaussian issue would be resolved by making equipment modifications.

If the non-zero HOS are in fact caused by environmental factors, then the existing signal processing algorithms, from which sonar system design is based, are not valid. Currently correlation detectors or energy threshold detectors are optimized, in the probability of detection/probability of false alarm (PD/PFA) sense for Gaussian beam reverberation statistics. If the signal is

not Gaussian, then non-Gaussian treatment of the RL data must be used to process the reverberation. Solinsky [Refs. 19-21] has shown that non-zero HOS algorithms can be designed which will efficiently mitigate the effects of reverberation.

A fundamental conclusion from this study is that the statistical distribution and its associated properties of the reverberation HOS needs to be determined in-situ and incorporated into the PD/PFA algorithms to improve echo to reverberation processing of the AN/SQS-53C sonar system. The HOS characteristics of the environment can be quantified through analysis of the abundant AN/SQS-53C data available in the Naval Undersea Warfare Center (NUWC) active sonar data base.

The non-Gaussian reverberation statistics problem can be addressed in several ways, including the development of a neural net (NN) algorithm, schematically illustrated in Figure 32. The NN approach can be adapted to the changing environment and this technique is highly recommended for further development for the AN/SQS-53C.

Another deterministic approach to addressing non-Gaussian statistics is to apply matched field processing (MFP) concepts. Here the transmitted signal replica is propagated through the shallow water environment using an accurate propagation model based upon accurate environmental

parameters determined by ITs such as the one developed in this thesis. Any procedure to process the transmitted waveform to accurately reflect the non-Gaussian characteristics of the environment will improve the correlation of the received energy which has been propagated in the environment and reflected off the target and other scatterers. If the transmitted waveform is not similar to that of the received energy, the correlation will be low and detection performance poor. On the other hand, if the volume, bottom and surface scattered returns correlate "too well" with the transmitted waveform, the active sonar system will be overloaded with false targets. MFP or neural net algorithms are ways to address the problem of non-Gaussian statistics by including the realities of propagation and scattering in shallow water in the processing of the transmitted waveform prior to correlation with received beam data.

THIS PAGE INTENTIONALLY LEFT BLANK

IV. CONCLUSIONS AND RECOMMENDATIONS

Exercise LWAD 99-1, which took place in February 1999, included an inversion technique experiment during which AN/SQS-53C reverberation data was collected. The reverberation data was used to investigate the possibility of employing inversion techniques to infer bottom sedimentary properties.

The hypothesis presented in this thesis was based on the assumption that the magnitude of backscattered energy and its rate of spatial decay were directly related to the acoustic reflectivity of the seabed. By examining the slope of the RL curves from various sedimentary provinces, one should be able to identify and associate various reverberant areas with unique sediment types. This study examined various reverberation level statistics including RL slope, standard deviation, skew, and excess kurtosis, to test this hypothesis. Of the various statistical parameters the RL slope was found to be most clearly aligned with the degree of bottom reflectivity. Over less reflective (mud/silt) bottoms a decrease in RL slope was noted while acoustic interactions with a more reflective bottom (sand) causes an increase in RL slope. Based on this finding, a technique was developed using the deviation of the RL slope for a particular ping/beam from an area-wide average RL slope to

generate a geographic map illustrating bottom sedimentary characteristics.

Analysis of higher order statistics (HOS), which included standard deviation, skew and excess kurtosis, revealed no clear correlation to sediment type. Variations in standard deviation and skew did provide indications of sedimentary change.

An analysis of the statistical distribution of the HOS indicated that the RL data did not derive from a Gaussian population. It also showed that the distribution did not appear to come from any well-known distribution (e.g., Poisson, log normal, Rayleigh, etc.). The non-Gaussian nature of the RL data has serious implications for sonar signal processing because most signal processing algorithms assume a Gaussian distribution to the noise field.

It is recommended that the RL slope technique for generating a sediment map be used by fleet assets as part of efforts to develop in-situ and archived bottom reflection databases and that these results be incorporated into shallow water ASW search planning. In addition, further investigation into the nature of RL statistics and its impact on sonar system performance should be undertaken.

APPENDIX A. FIGURES

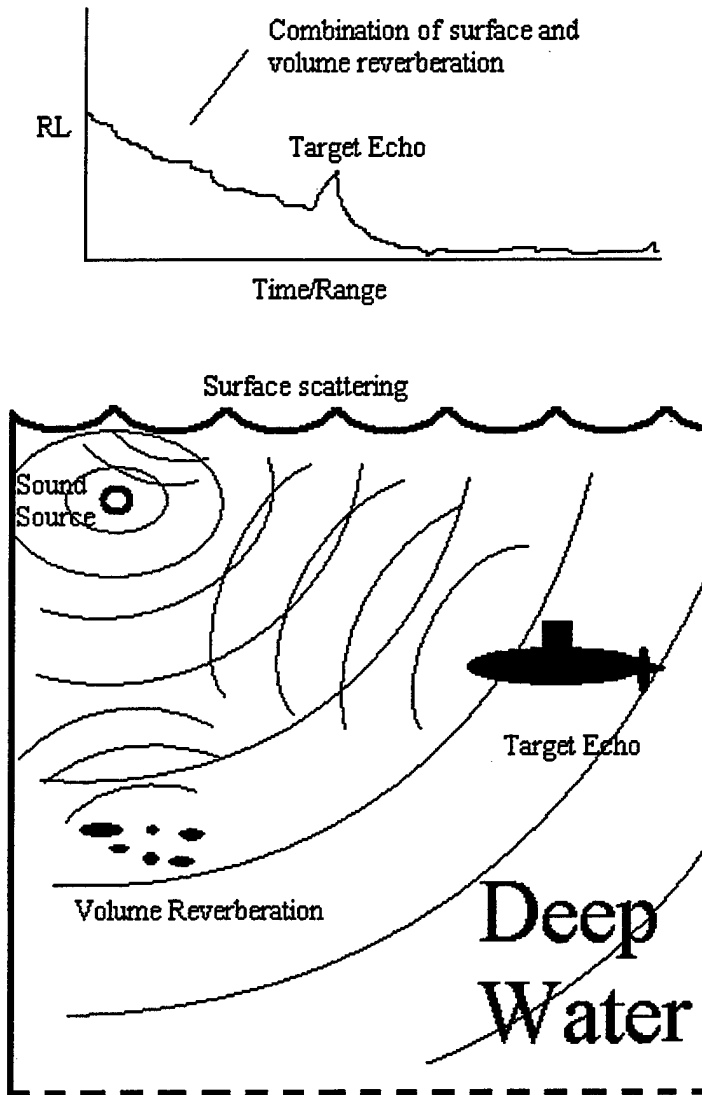
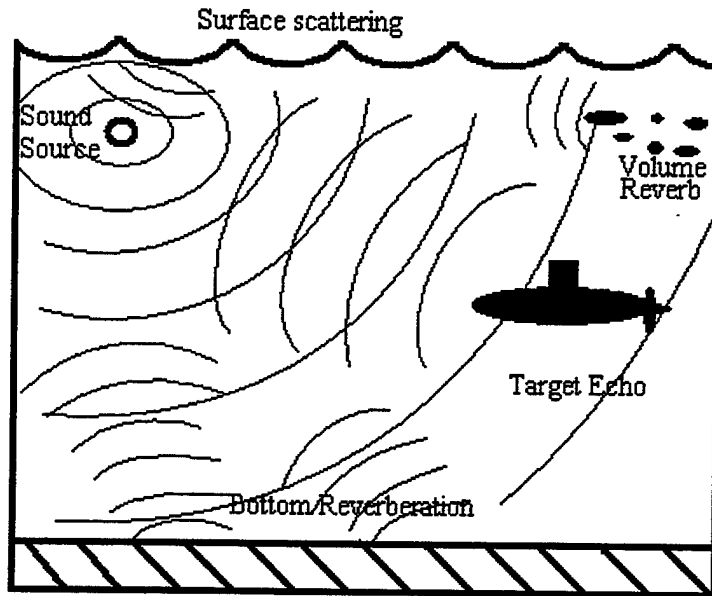
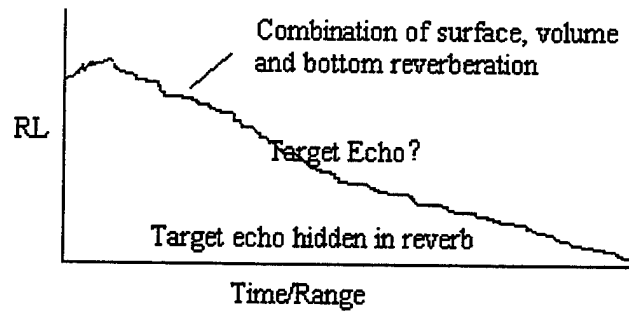

Figure 1. Schematic and characteristic RL curve for a deep water environment. Reverberation is due primarily to backscattering from volume and sea surface scatterers.



Shallow Water

Figure 2. Schematic and characteristic RL curve for a shallow water environment. Reverberation is generally louder being a function of volume, sea surface, and bottom backscatterers. High RL levels often mask the target echo.

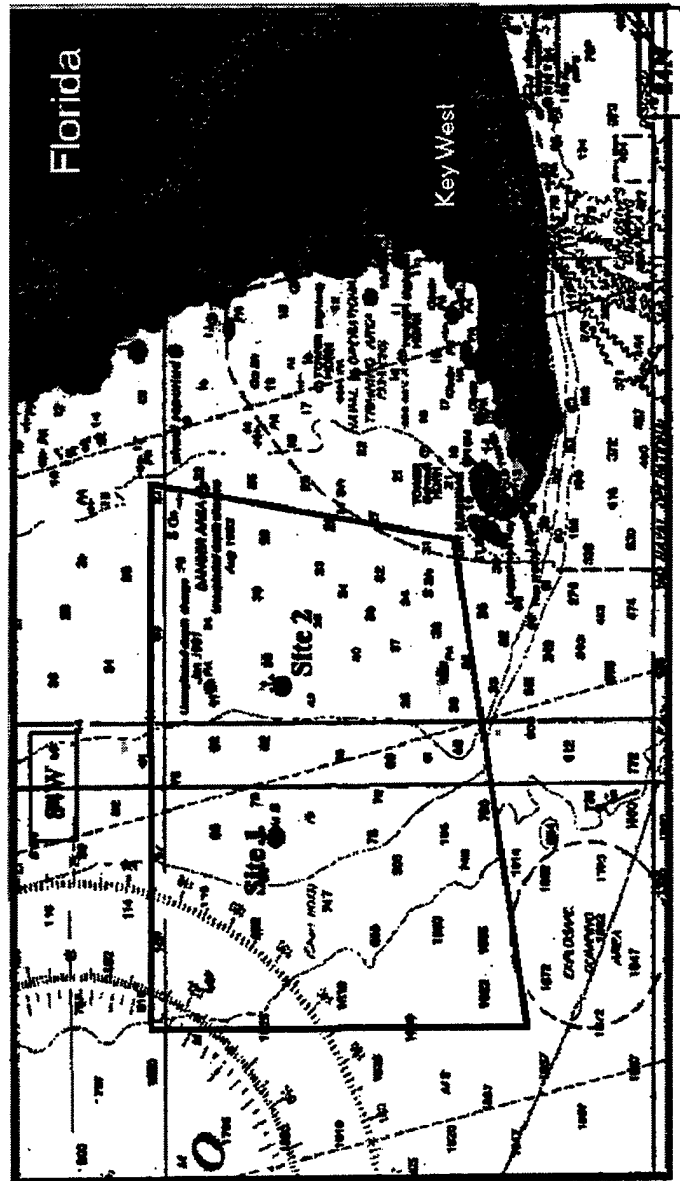

Figure 3. LWAD 99-1 Exercise Area. Event 31 (Inversion Techniques) was conducted at site 1. Depths in meters. From Ref. [9].

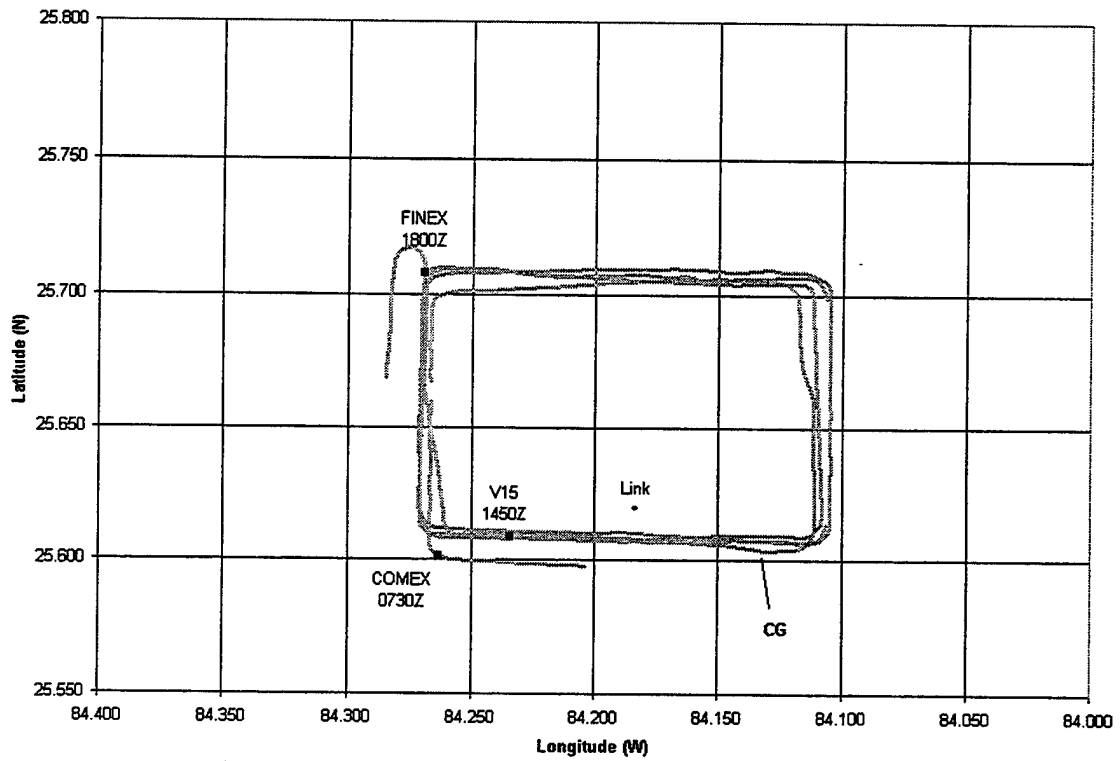

Figure 4. Event 31 experiment geometry. Over 900 pings of the AN/SQS-53C tactical sonar were completed between 0730Z and 1800Z on 9 February 1999. From Ref. [10].

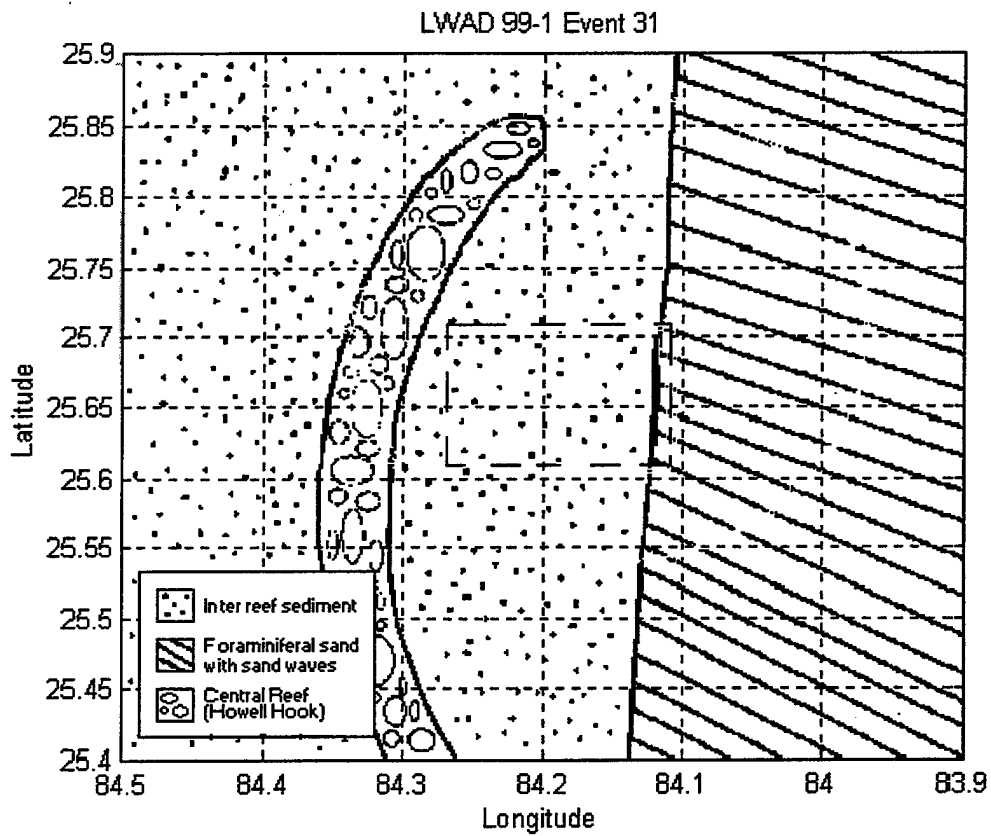

Figure 5. Exercise LWAD 99-1 surface sediment distribution. After Ref. [11].

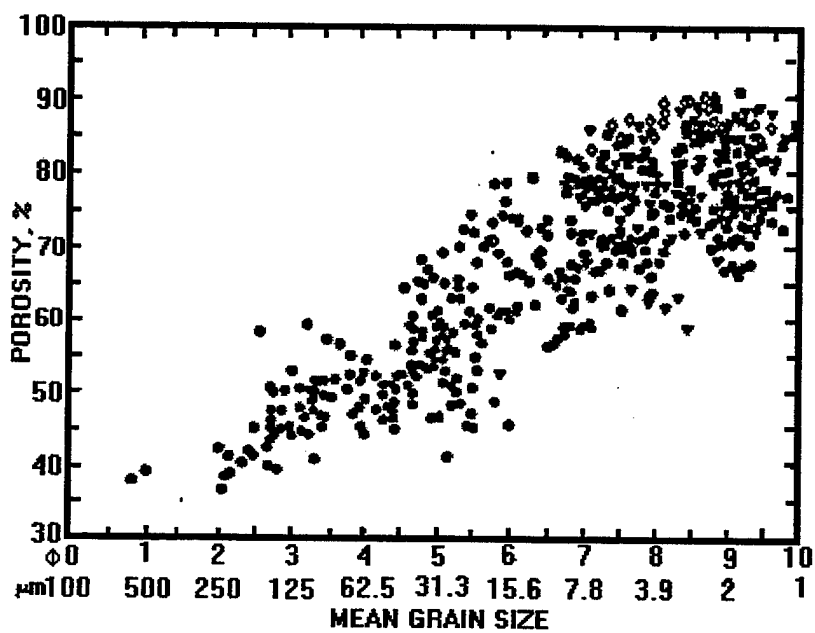

Figure 6. Mean grain size versus porosity. Round dots represent continental terrace (shelf and slope) samples. From Ref. [14].

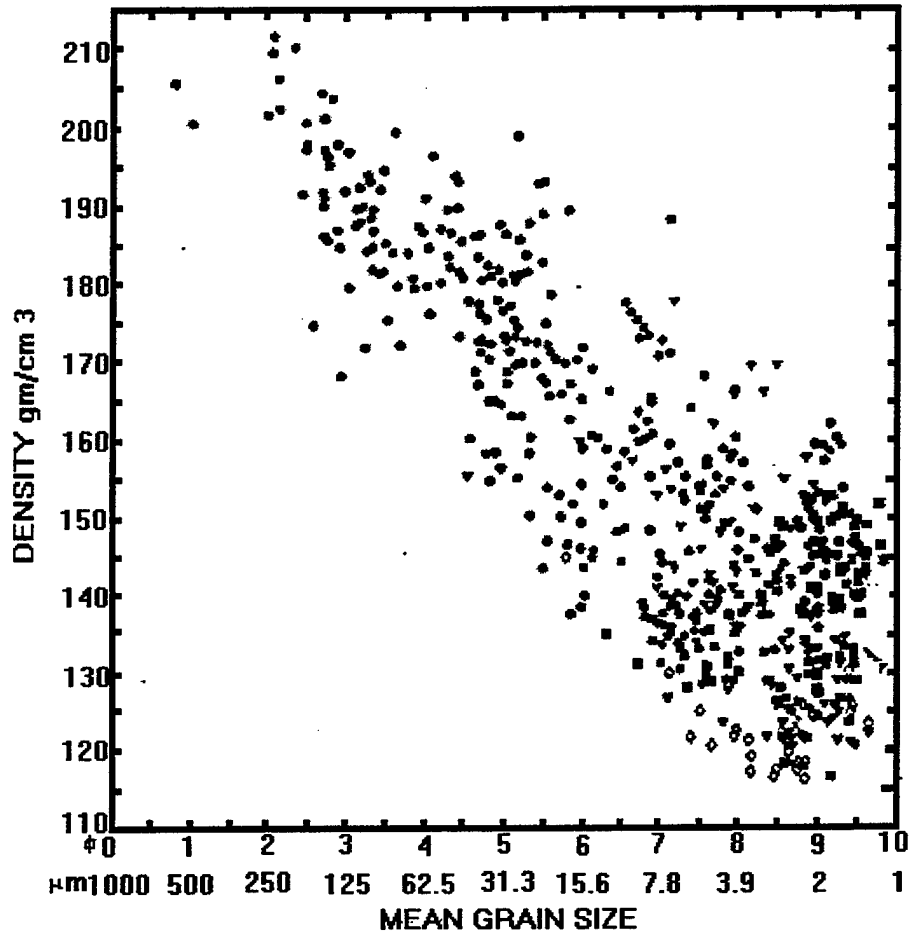

Figure 7. Mean grain size versus saturated bulk density. Round dots represent continental terrace (shelf and slope) samples. From Ref. [14].

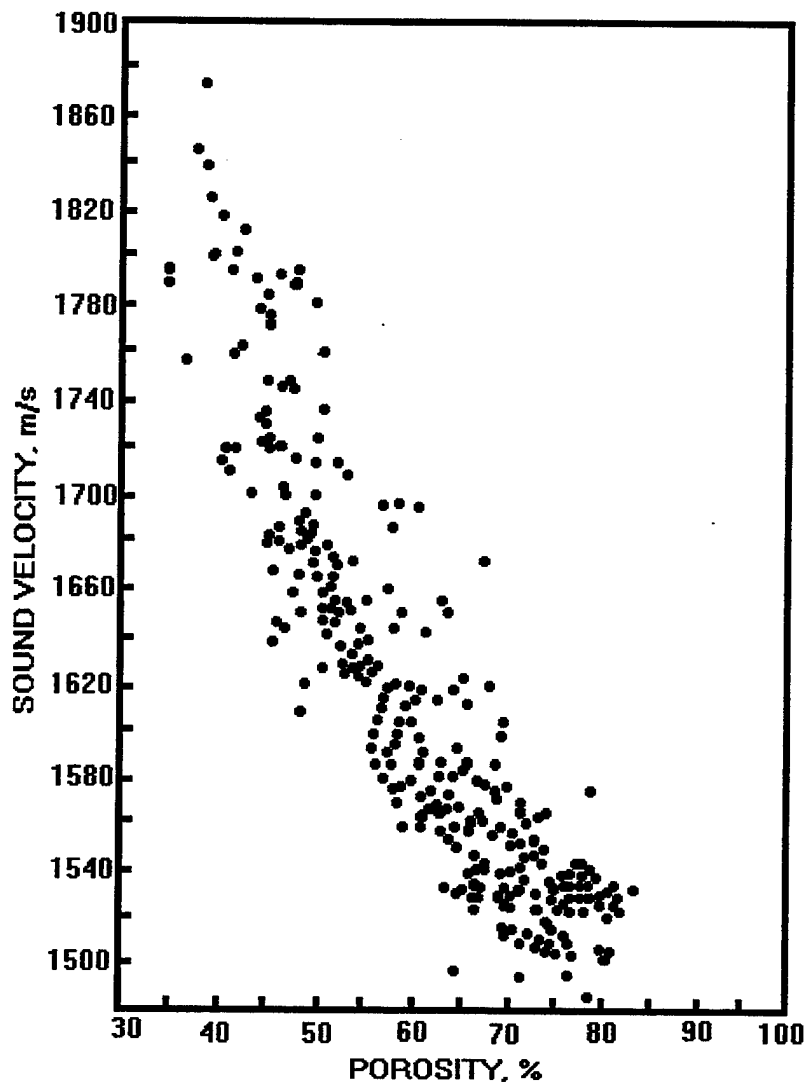

Figure 8. Porosity versus sound velocity, continental terrace (shelf and slope). From Ref. [14].

SITE 1 CTD DOWNCASTS

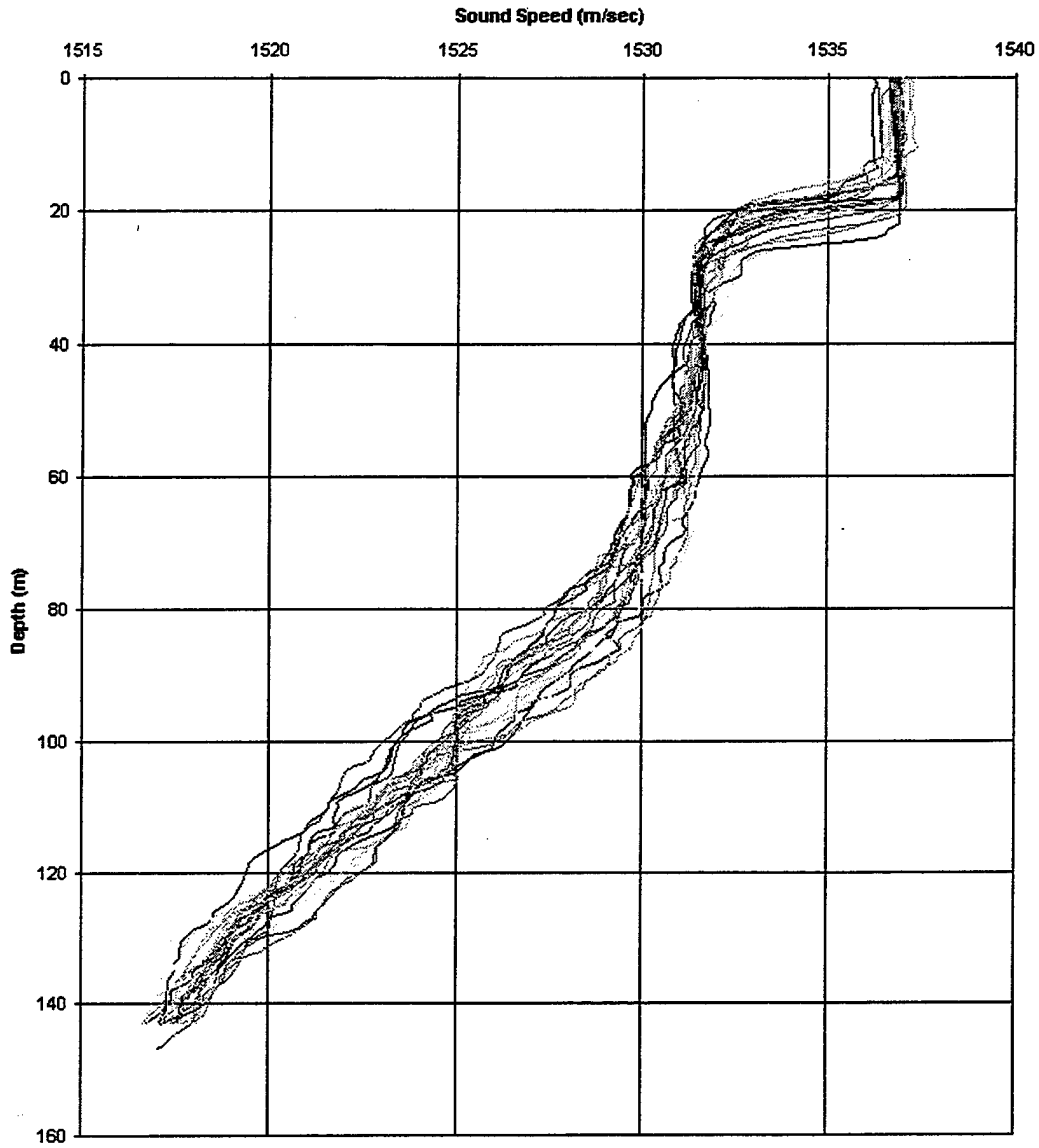

Figure 9. 23 total CTD downcasts were taken at site 1 from 2/6/99 to 2/9/99. Bottom interaction of acoustic energy is ensured due to downward refracting nature of sound speed profile (SSP). From Ref. [15].

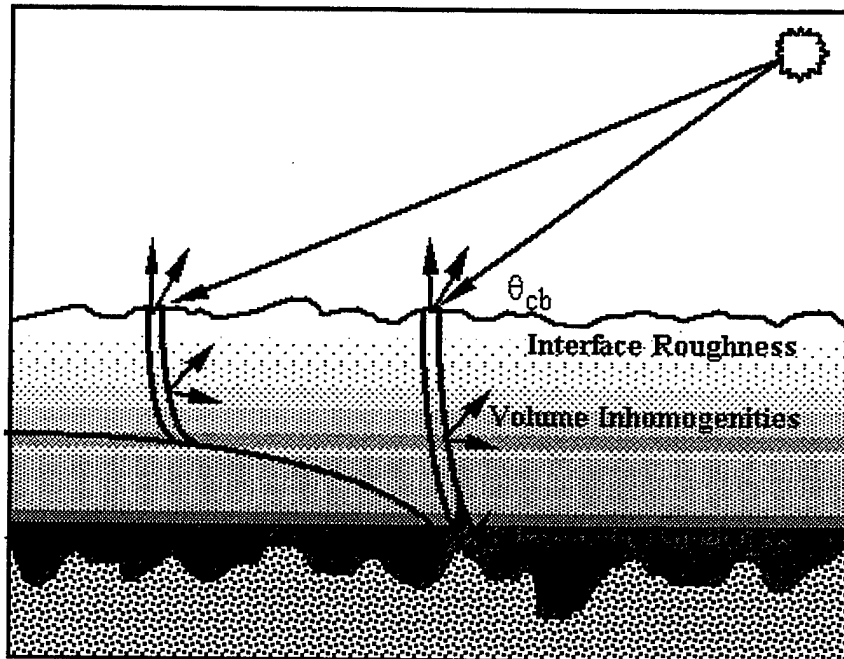

Figure 10. Scattering mechanisms are from (1) the water-sediment interface, (2) sub-bottom volume, and (3) the sediment-basement interface. From Ref. [17].

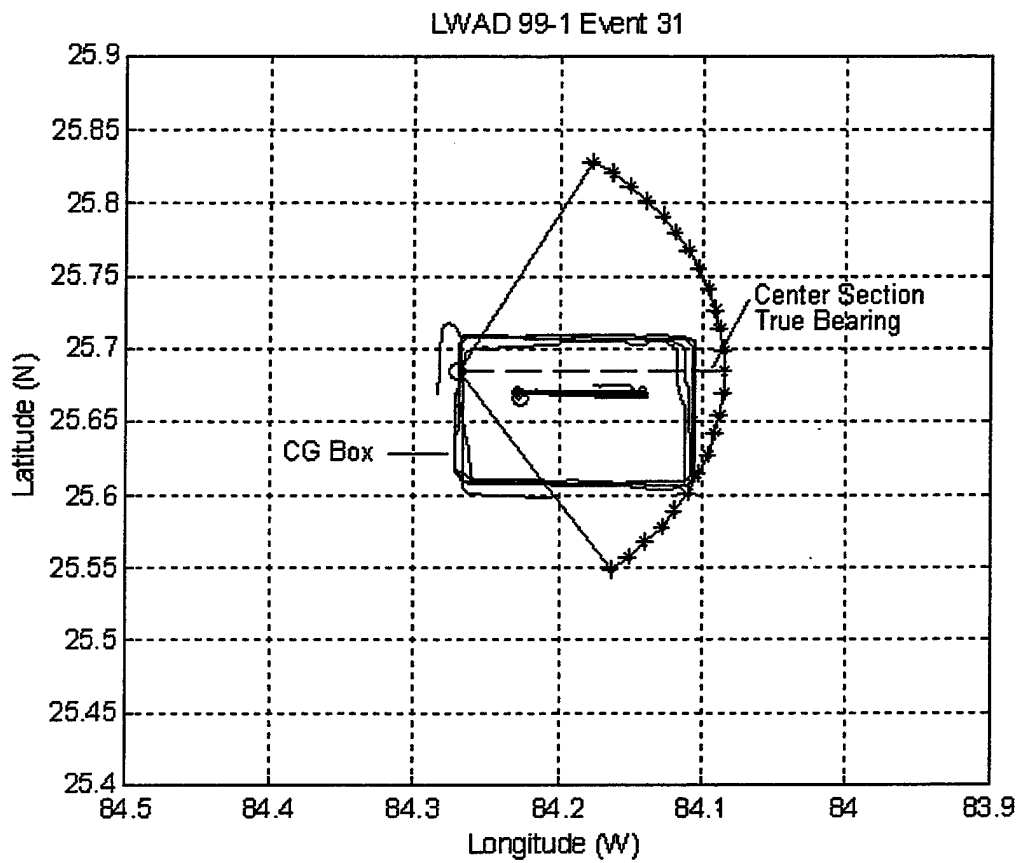

Figure 11. VD-mode ping with center section true bearing of $090^{\circ}T$. VD-mode pings are steered toward the center of the CG box.

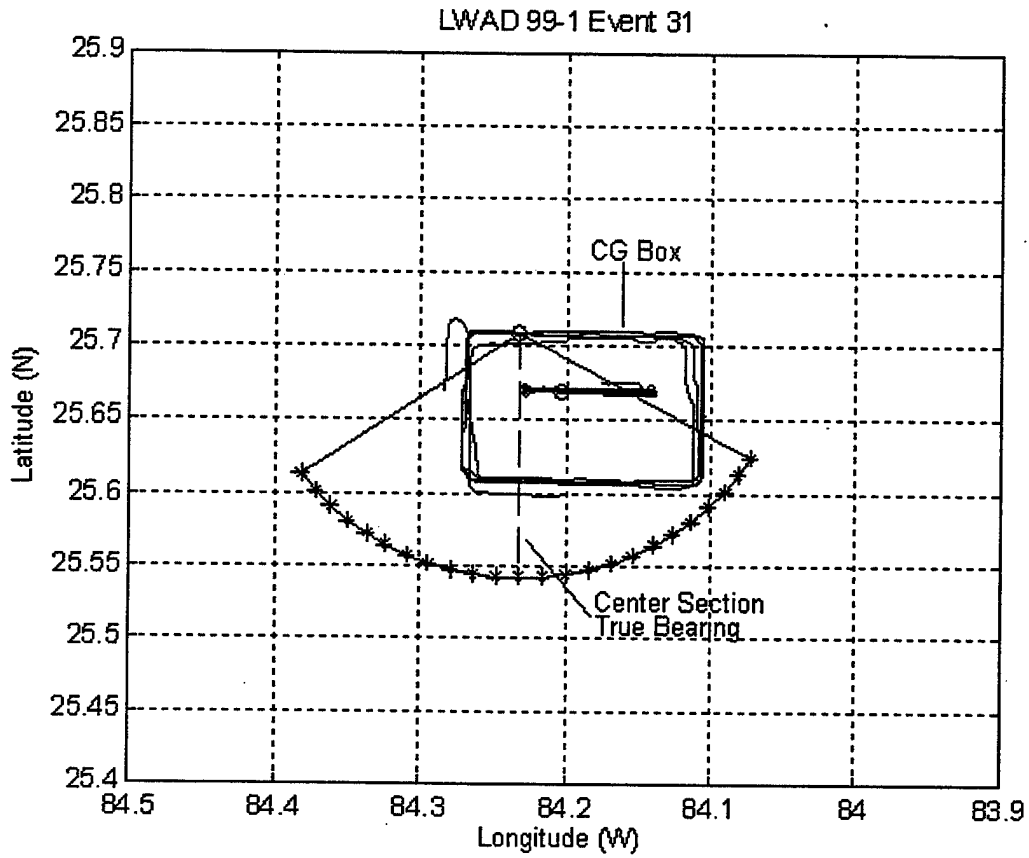

Figure 12. VD-mode ping with center section true bearing of $180^{\circ}T$. VD-mode pings are steered toward the center of the CG box.

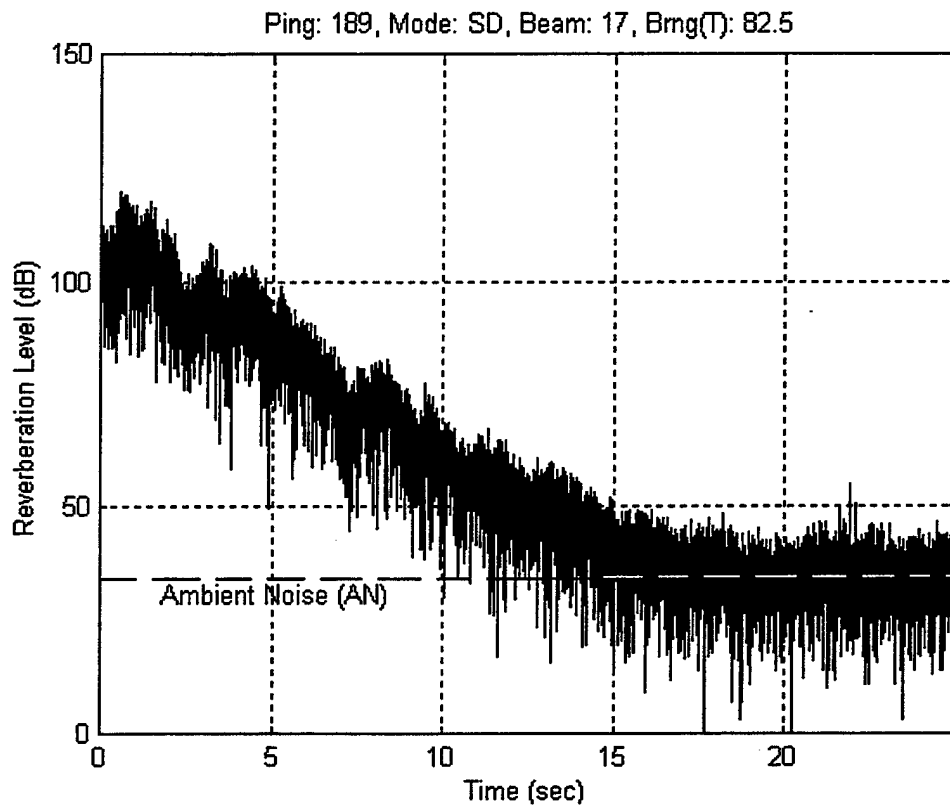

Figure 13. RL time series for a forward projected beam. RL reduces to the ambient noise (AN) level of approximately 35 dB at about 18s. Compare with Figure 14 (stern beam) to see difference in AN level.

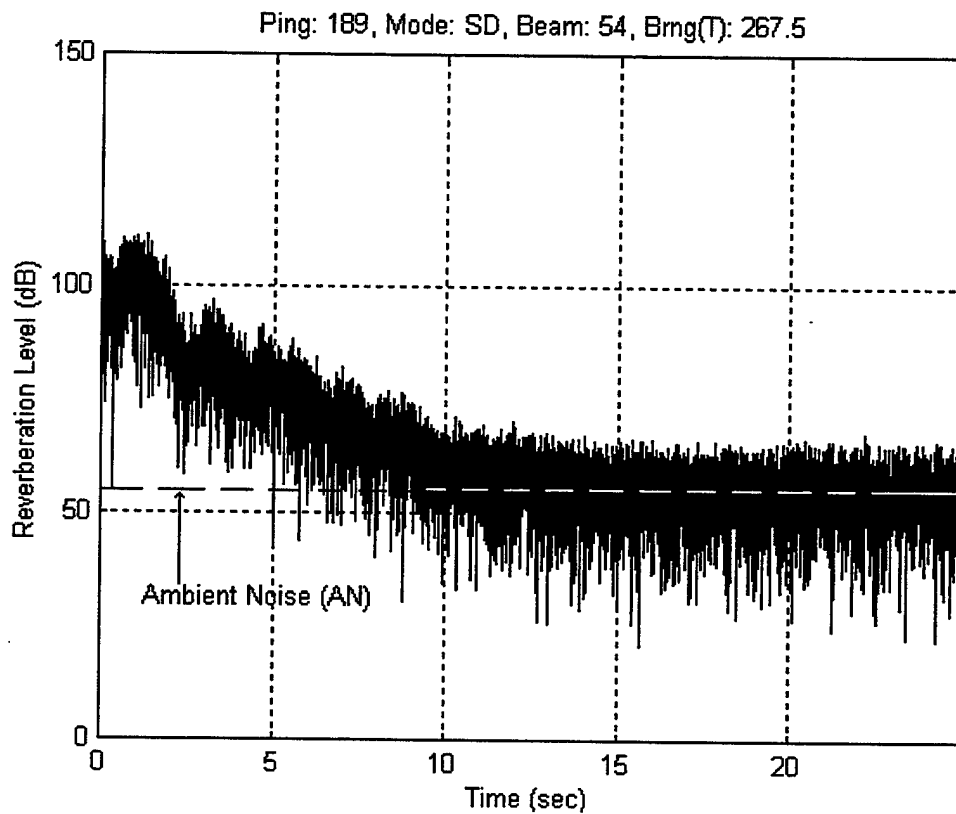

Figure 14. RL time series of stern beam. The ambient noise (AN) level is approximately 20 dB greater than non-stern beam due to ship noise.

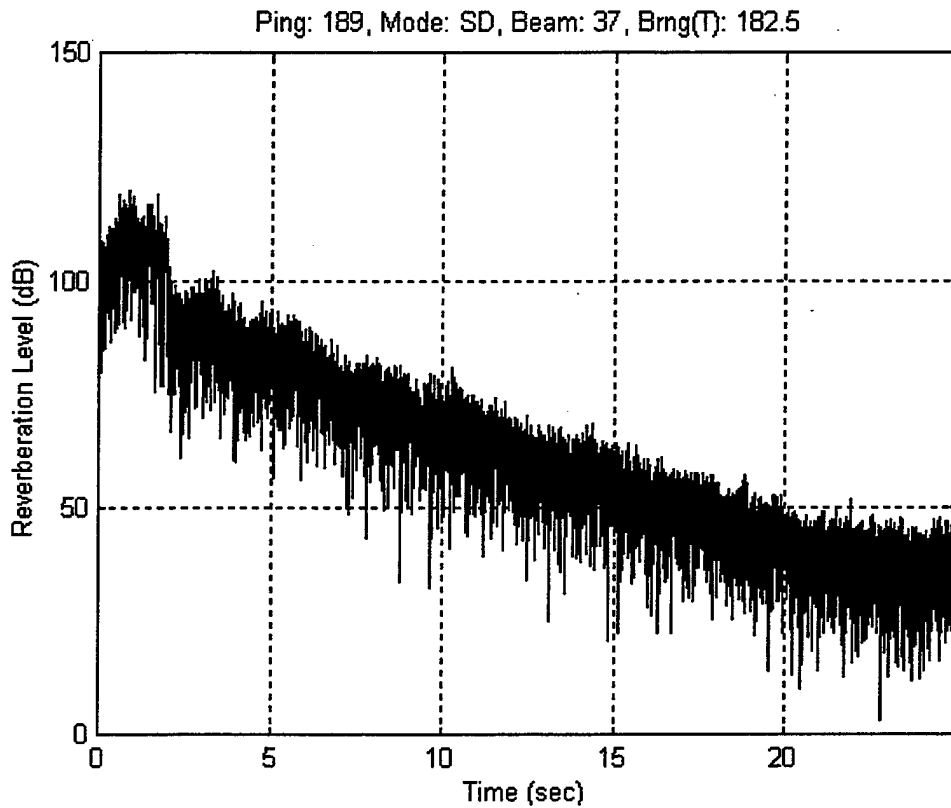

Figure 15. RL curve reduces to background noise level at around 23.5 s. Compared to figure 13 the longer RL decay time is associated with backscattering from a more reflective bottom.

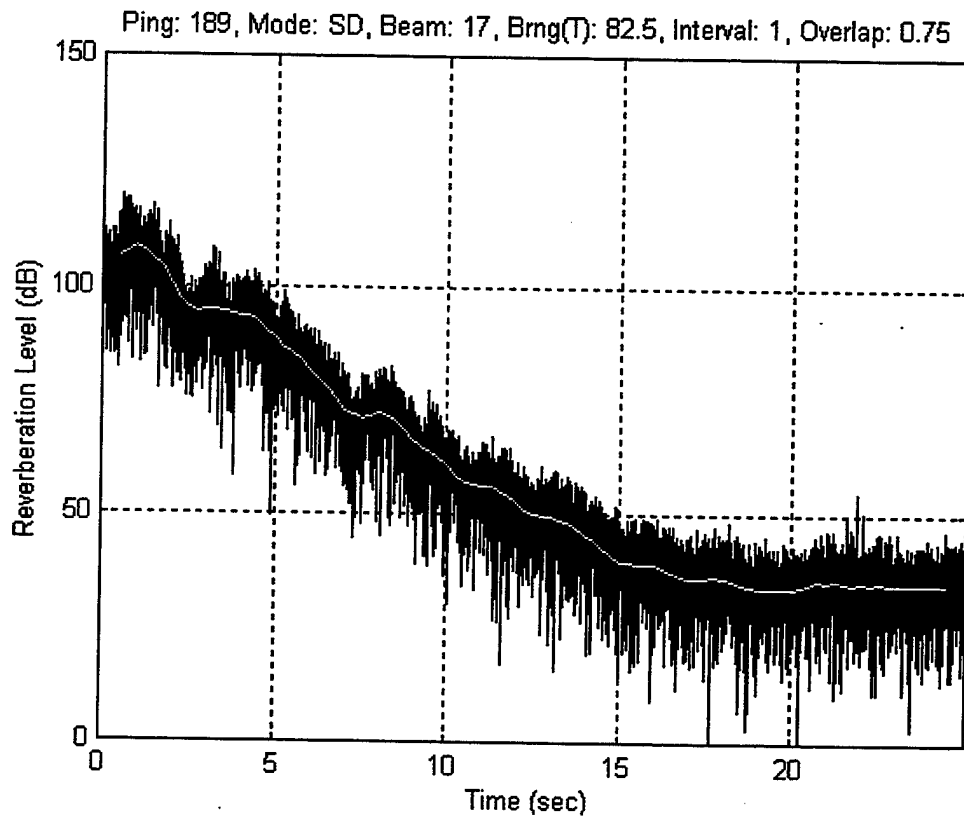

Figure 16. Individual RL time series (black) overlaid by the 1/0.75 moving mean (white) RL curve.

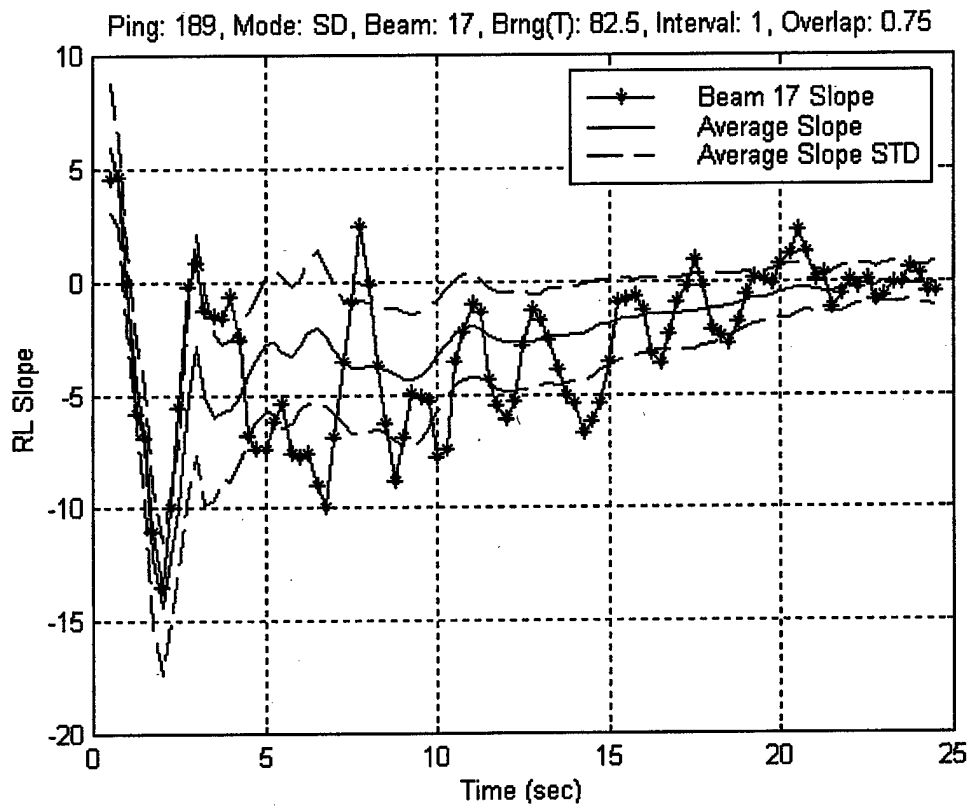

Figure 17. Slope of the 1/0.75 moving mean (-*) for an individual beam compared with the area-wide average slope (solid line) and its standard deviation (--).

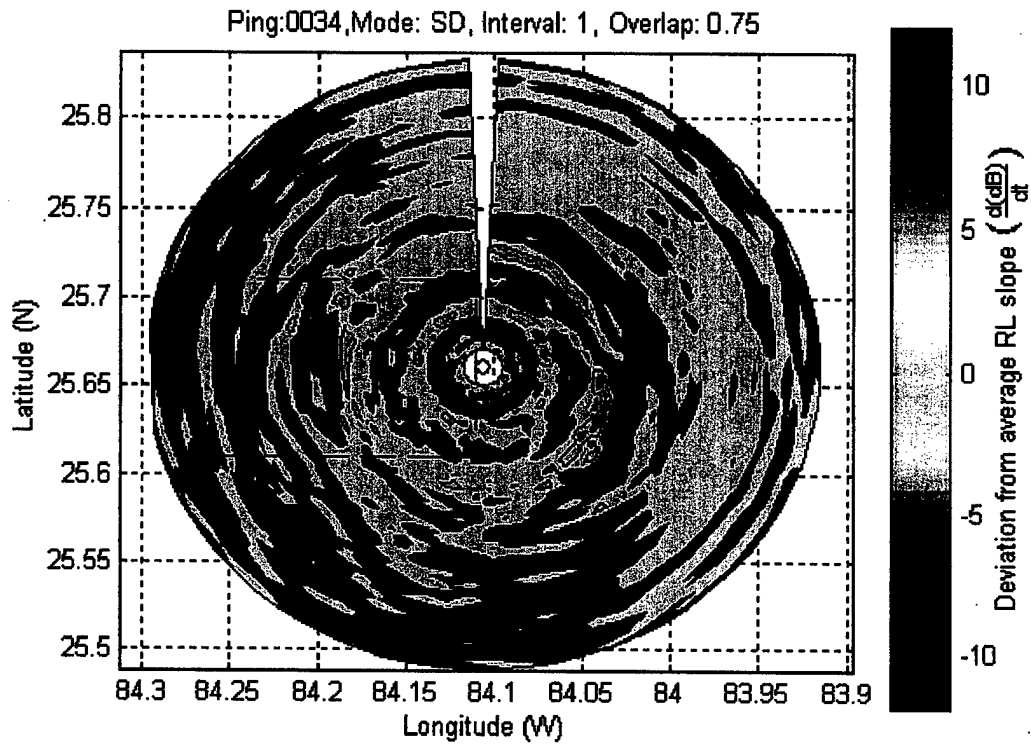

Figure 18. Ping 34. Geographic contour plot of deviations of all 72 beams of slope data from the area-wide average slope. Warmer colors represent more reflective sedimentary areas than the cooler colors.

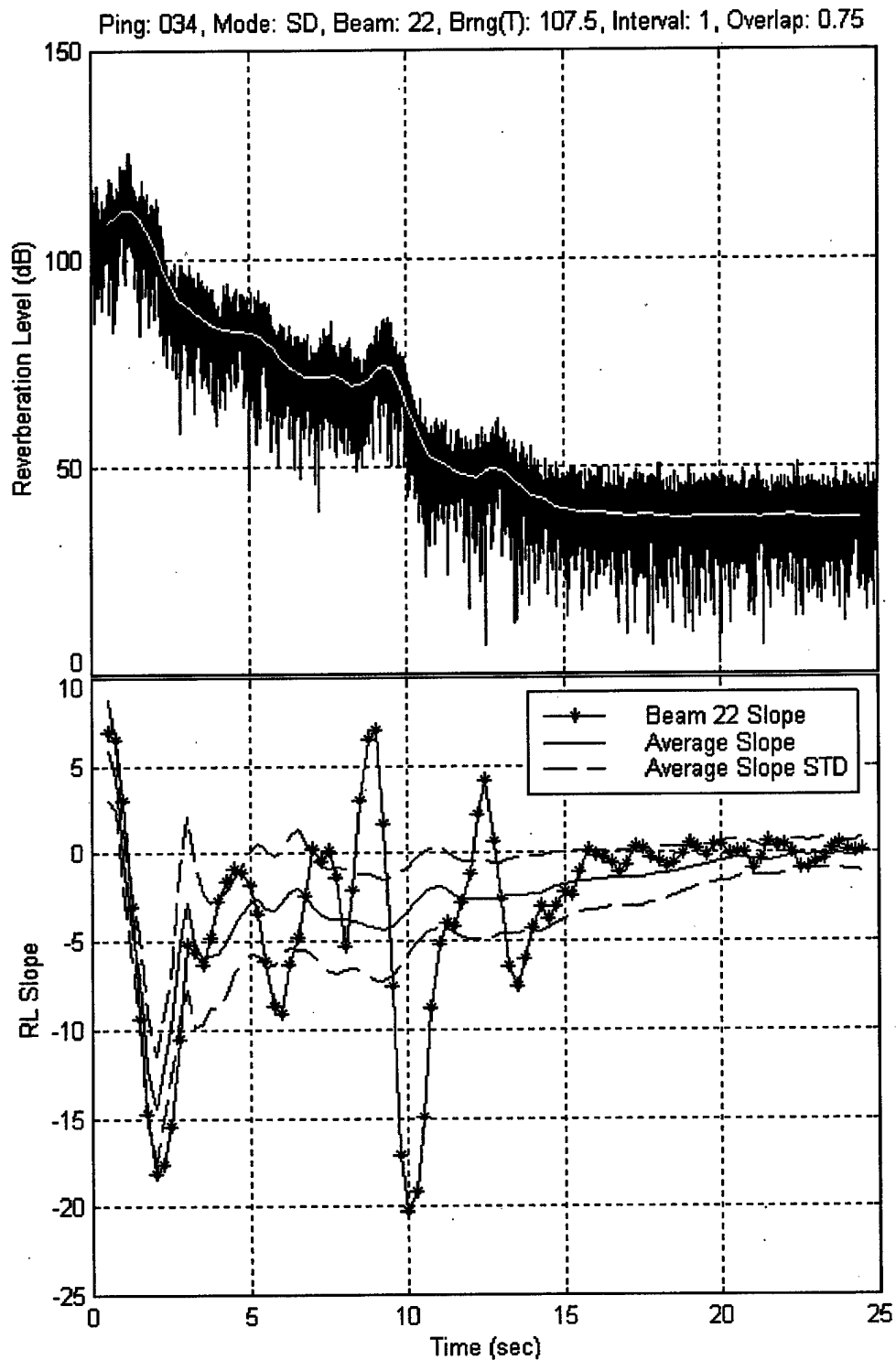

Figure 19. Ping 34, beam 22. An increase in RL at 8.5 s corresponds with an increase in RL slope.

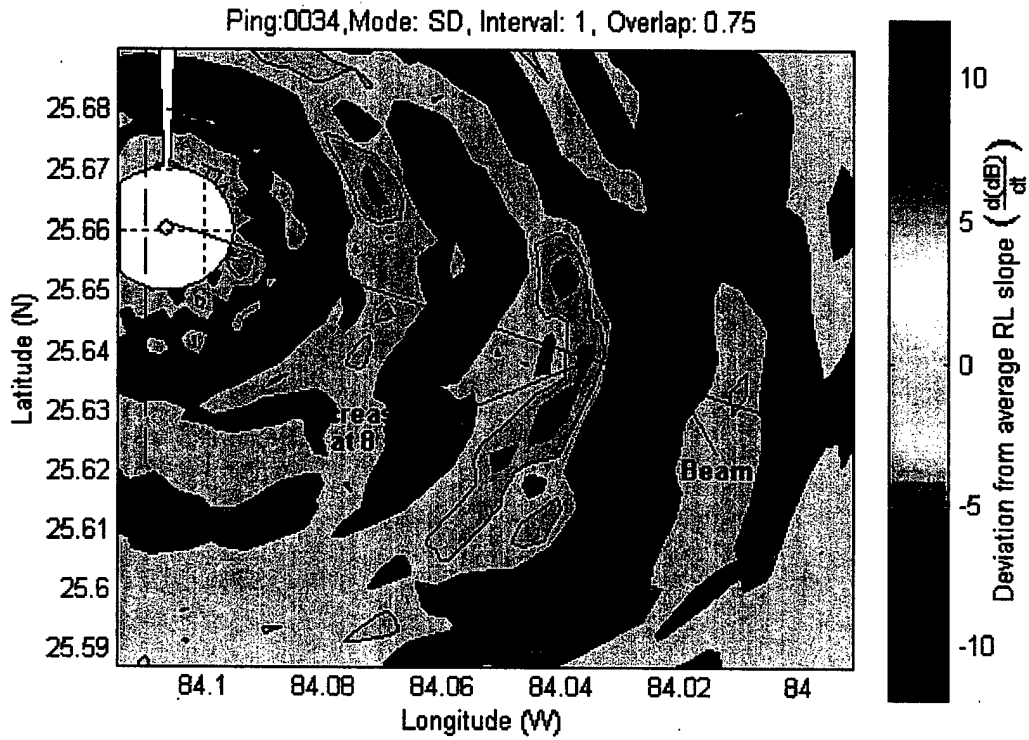

Figure 20. Ping 34, beam 22. Enlarged contour plot to display the region of increased RL.

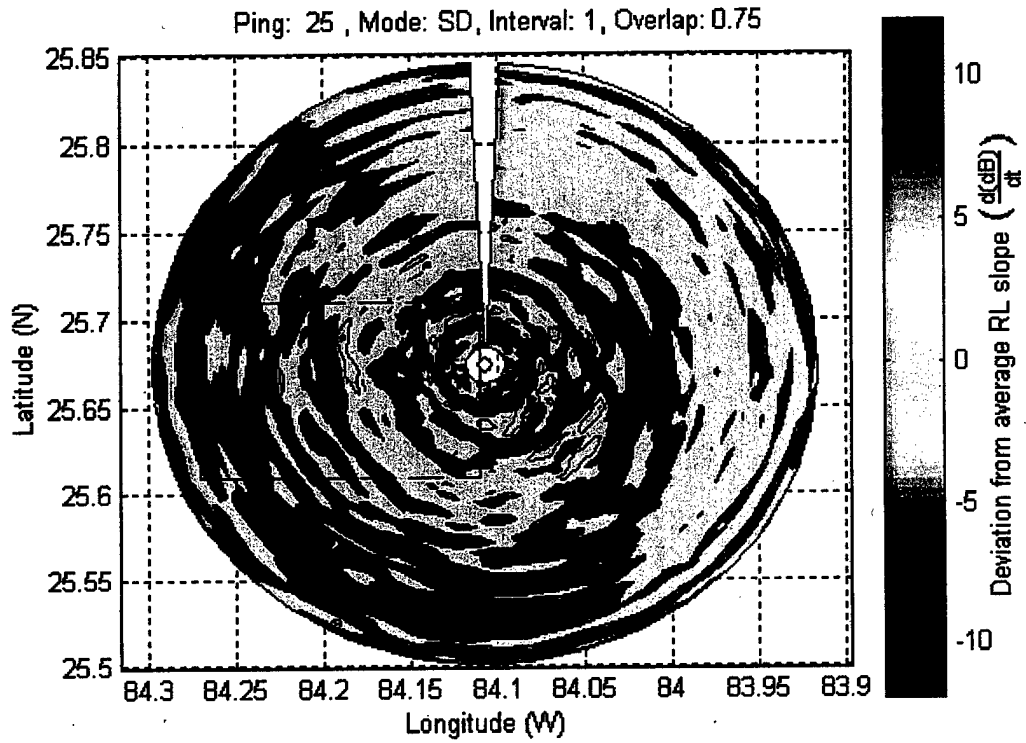

Figure 21. Ping 25. Note region of increased RL at same geographic location as Ping 34.

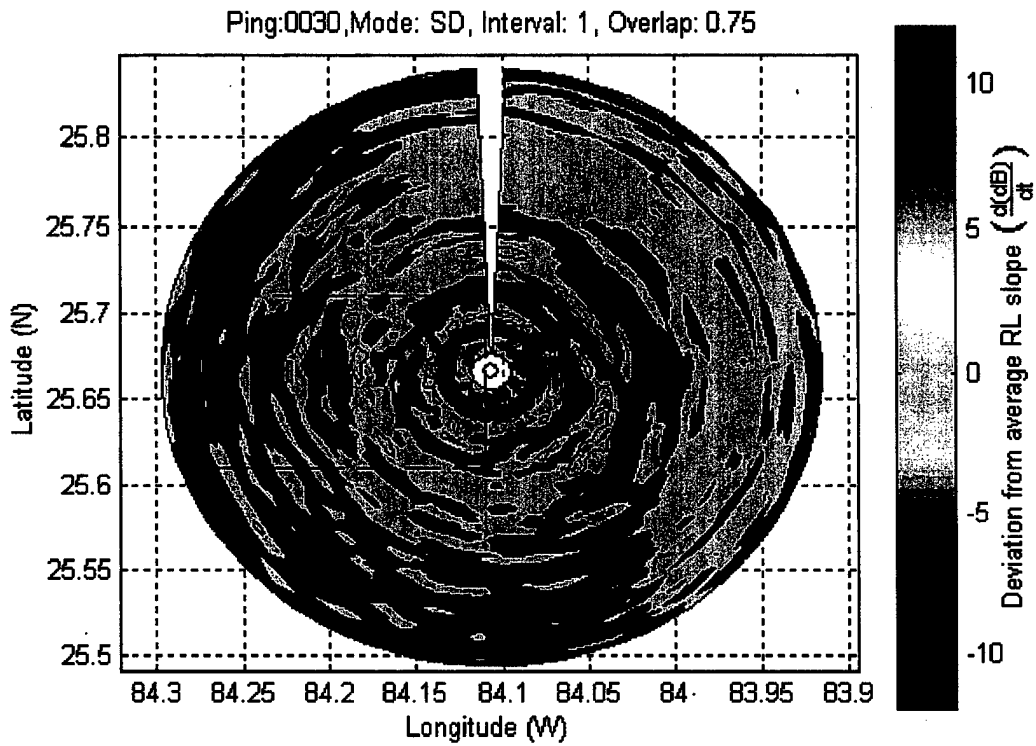

Figure 22. Ping 30. Note region of increased RL at same geographic location as Ping 34.

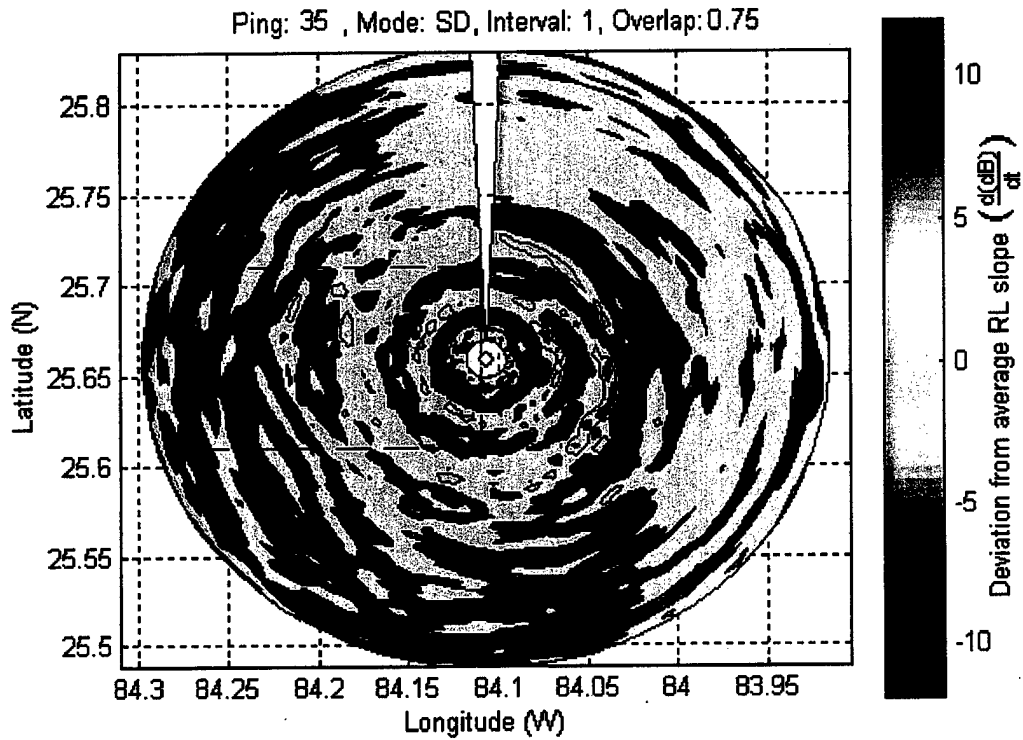

Figure 23. Ping 35. Note region of increased RL at same geographic location as Ping 34.

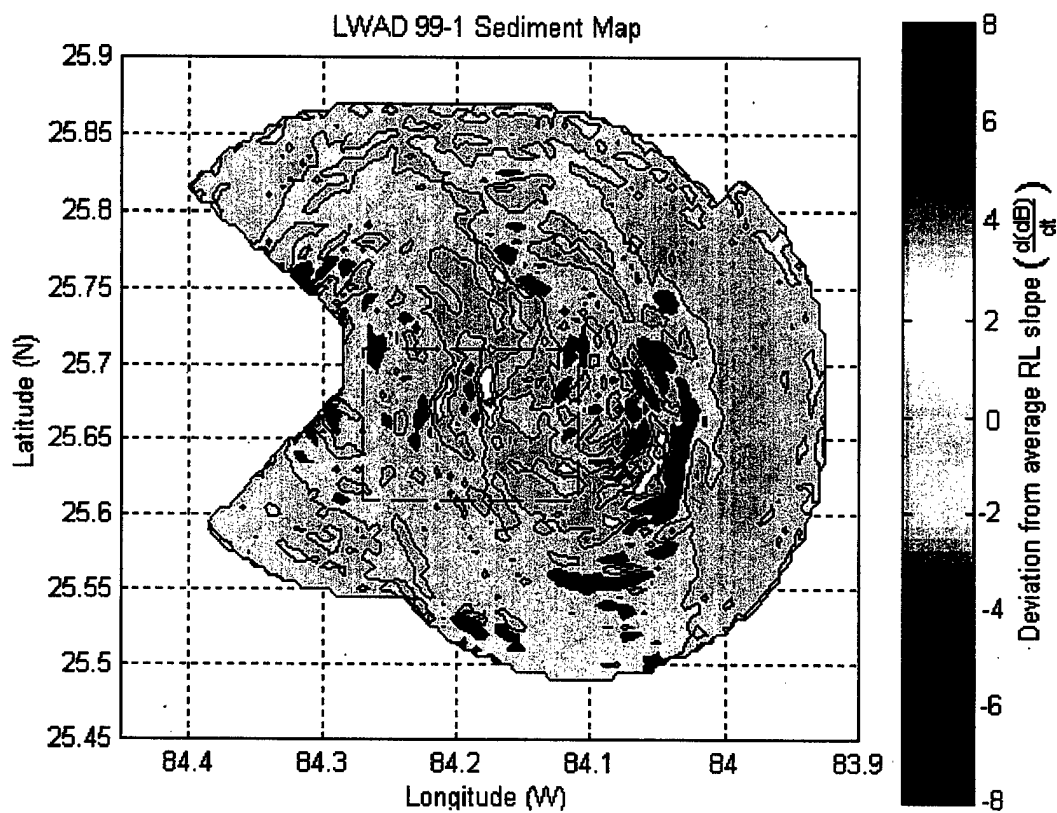

Figure 24. Composite plot of deviation of RL slope from the area-wide average for 41 SD mode pings. Warmer colors represent more reflective sedimentary areas than the cooler colors.

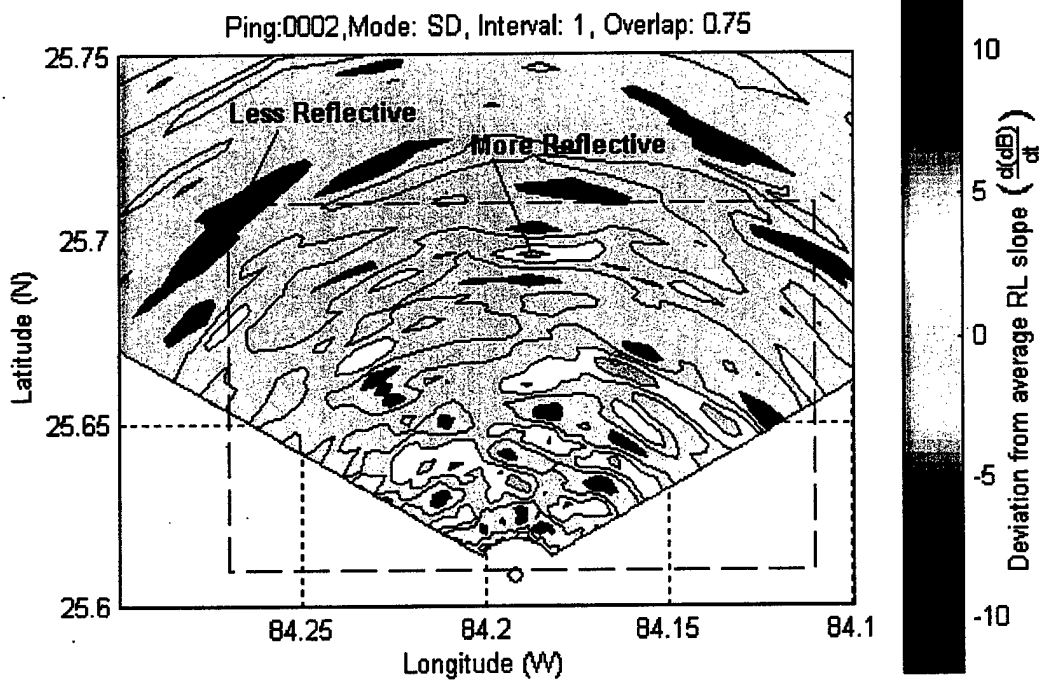

Figure 25. VD-mode ping 2. Note that the features pointed out are also seen in the SD-mode composite plot.

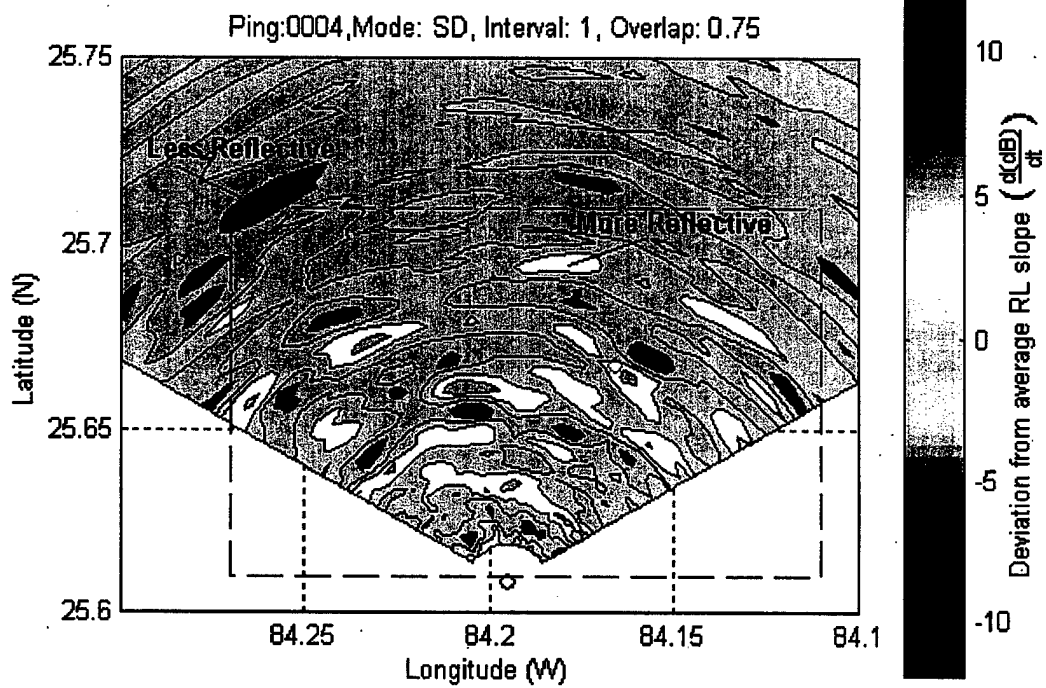

Figure 26. VD-mode ping 4. Note that the features pointed out are also seen in the SD-mode composite plot.

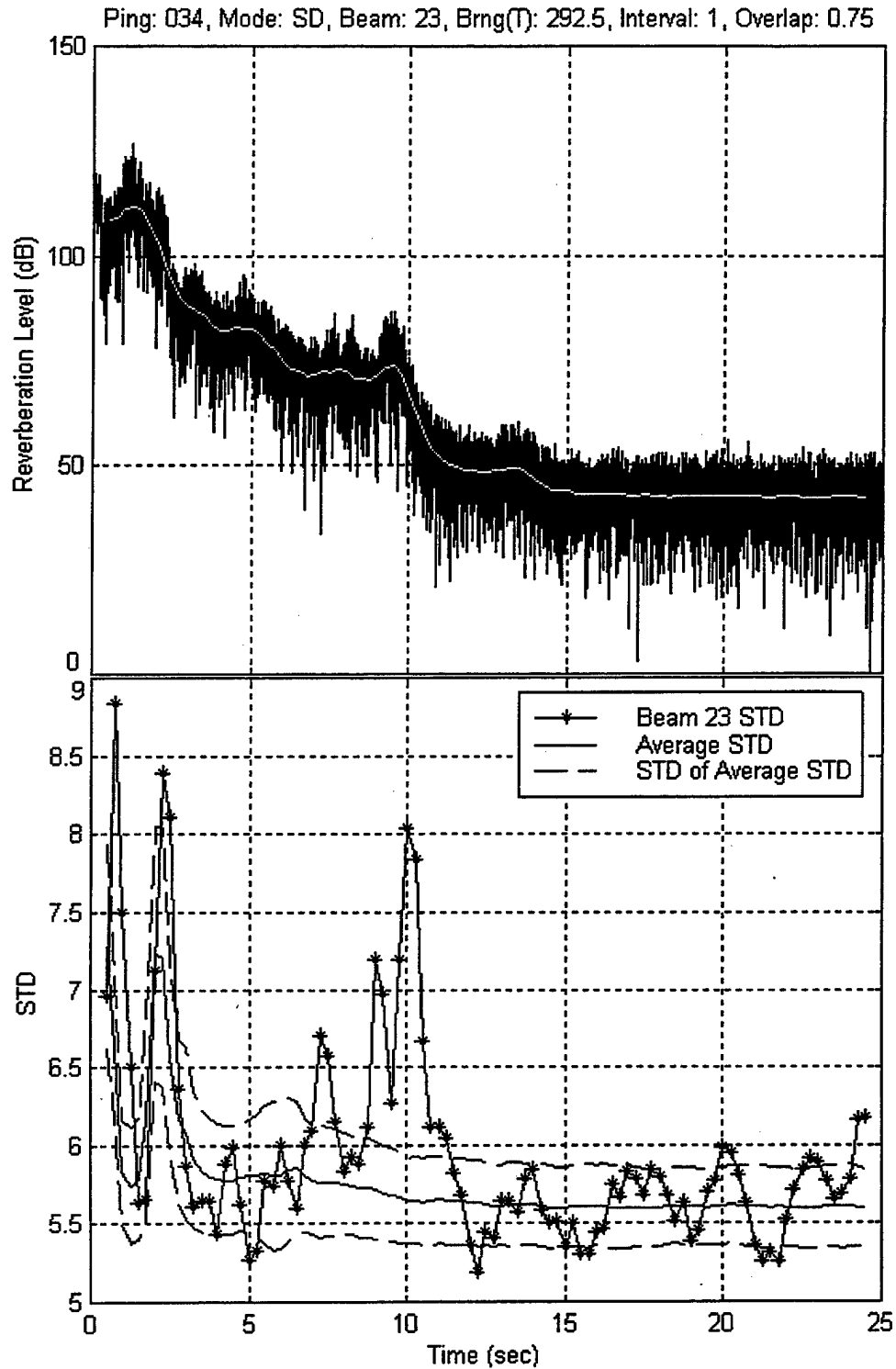

Figure 27. Ping 34, beam 22. An increase in RL at 8.5 s corresponds to an increase in RL STD.

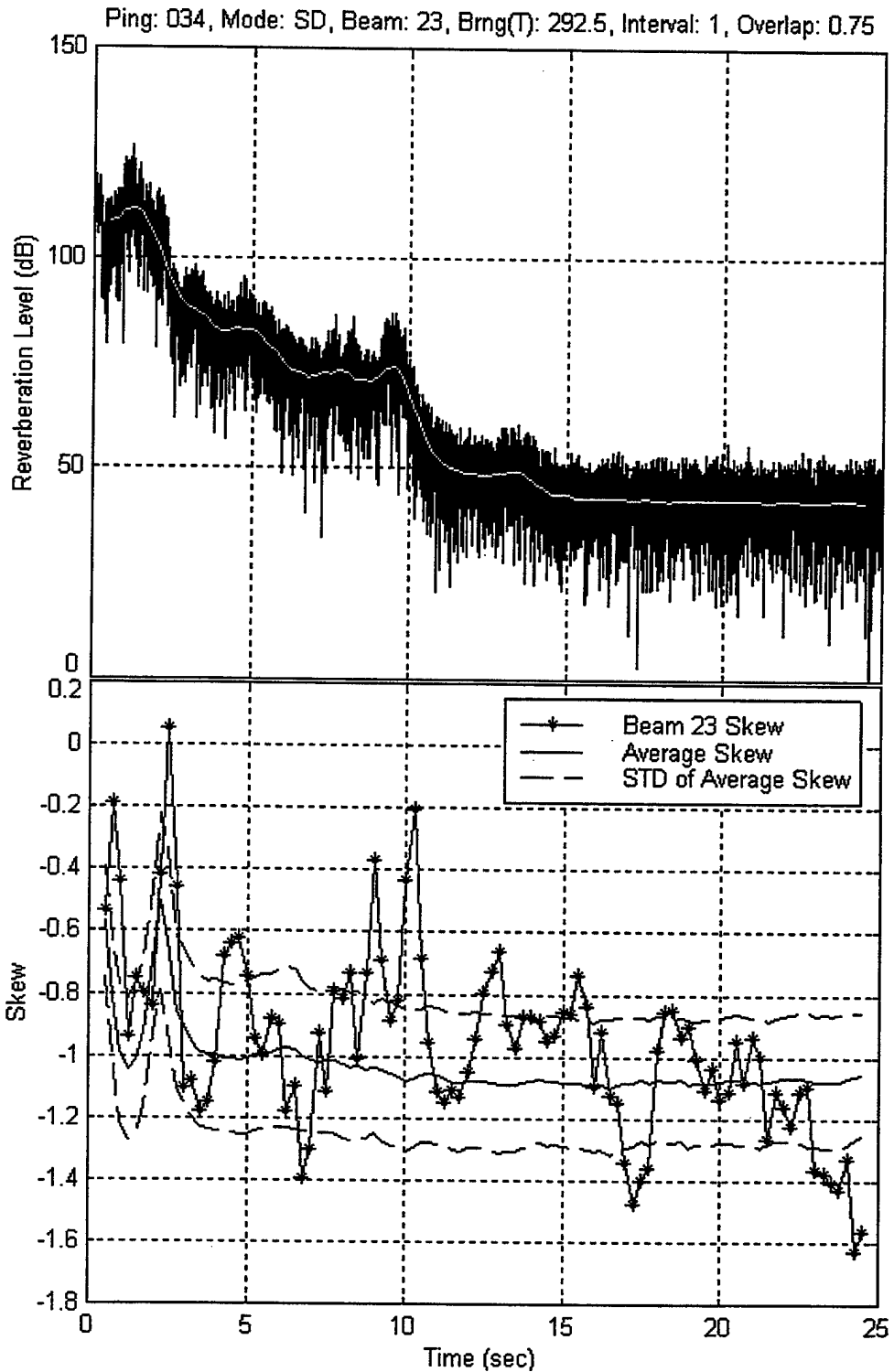

Figure 28. Ping 34, beam 22. An increase in RL at 8.5 s corresponds to an RL skew feature.

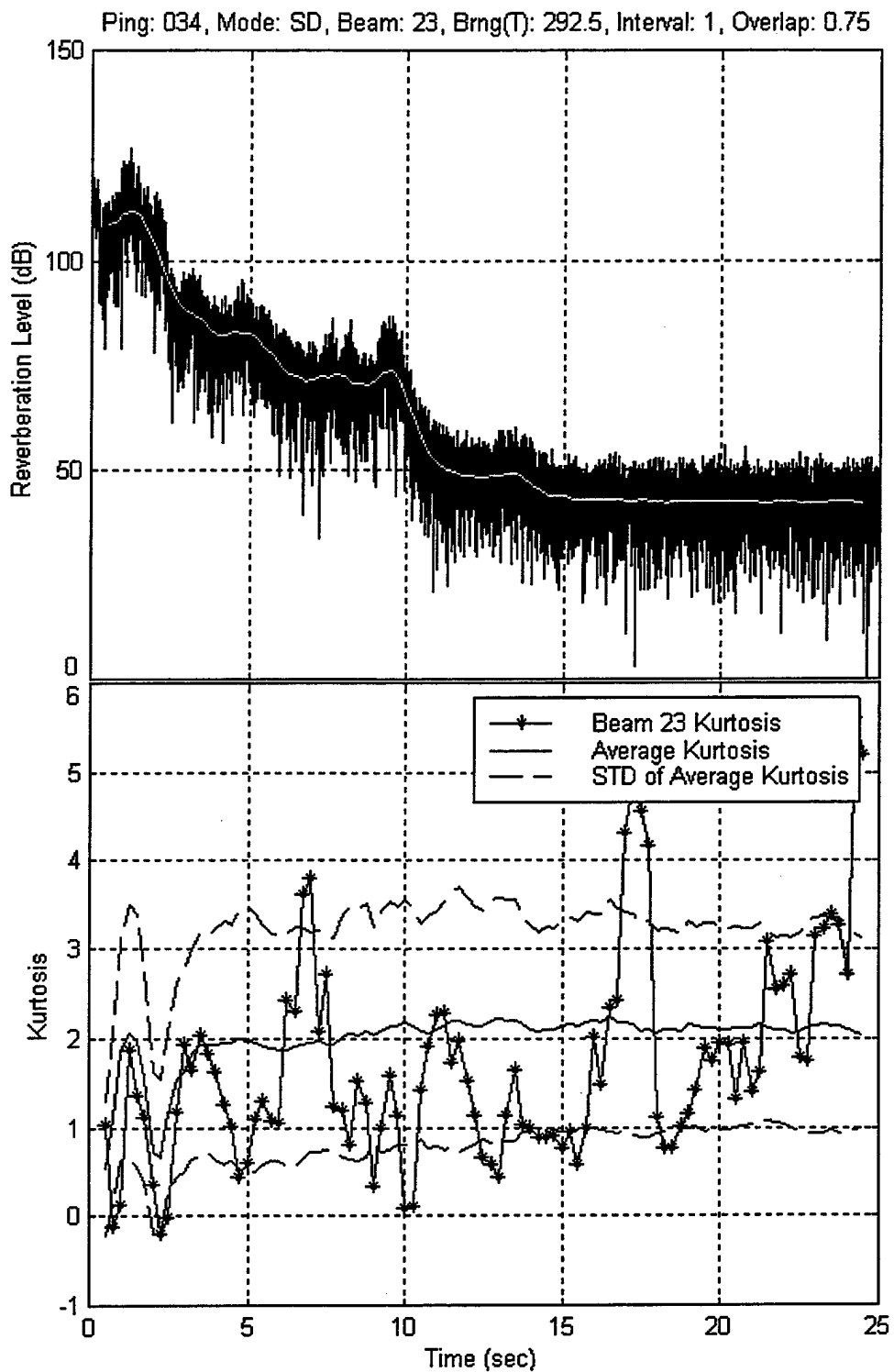

Figure 29. Ping 34, beam 22. The RL kurtosis features appear random with no apparent correlation to RL.

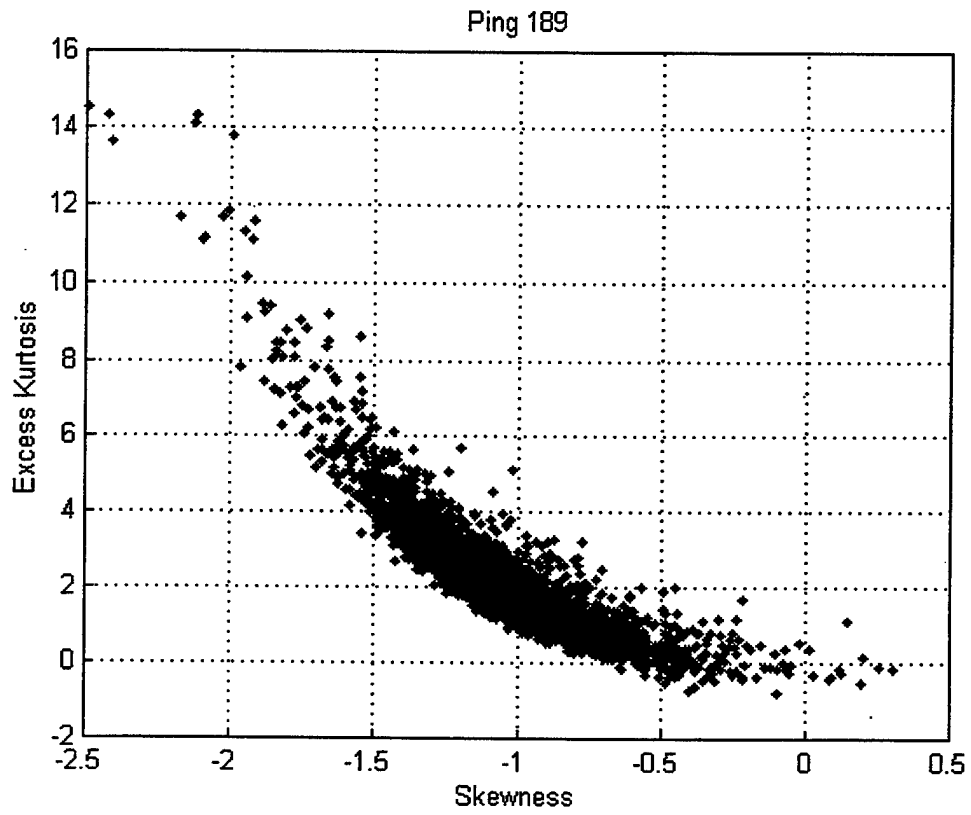

Figure 30. Skew vs. excess kurtosis for the detrended beam reverberation data of ping 189.

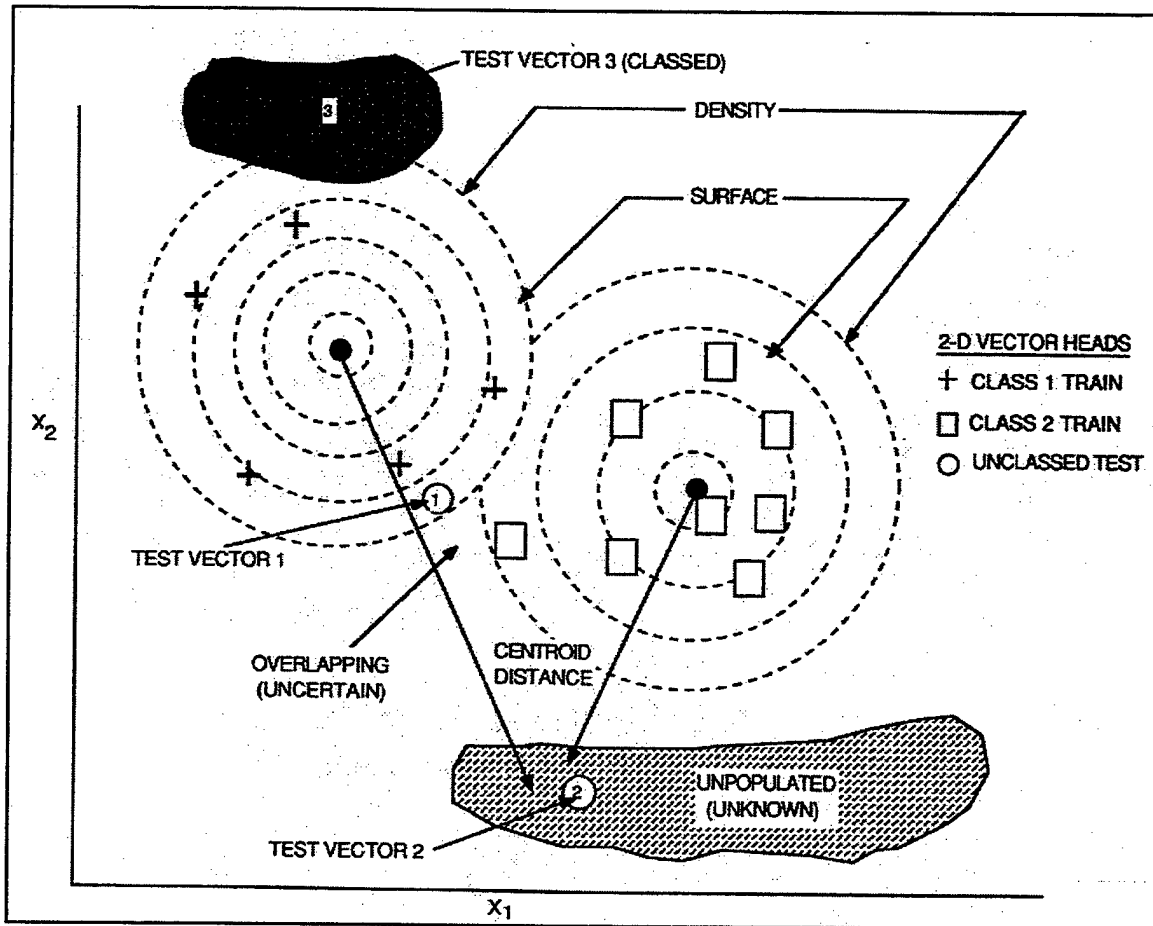

Figure 32. Two-Dimension feature space. From Ref. [21].

APPENDIX B. MATLAB FILES

The matlab program files enclosed are for analyzing beamform data from exercise LWAD 99-1. The program files do not include the actual beamform ping data, or the ping parameter files. The matlab files included here are for guidance in creating a graphical user interface (GUI) for analyzing beamform data.

Beamform data files contain the following variables:

bandwidth - bandwidth(Hz)
bmf - complex beamform data
centerfreq - center frequency (Hz)
ping_date - date (e.g. '02/09.99')
ping_time - time (e.g. '11:18:15')
pulselength - pulse length (ms)
samplerate - samplerate (Hz)

The parameter file 'evt31.mat' contains a vector of times and corresponding CG and TGT positions from LWAD 99-1 event 31:

evt31_time - time in seconds from midnight
evt31_date - event 31 date (e.g. '02/09.99')
cg_lat - vector of CG latitudes
cg_lon - vector of CG longitudes
tgt_lat - vector of TGT latitudes
tgt_lon - vector of TGT longitudes

The parameter file 'evt31prm.mat' contains a vector of times and corresponding ping parameters:

botdepth - bottom depth (fm)

course - CG course ($^{\circ}$ T)

ctrbrng - Center of ping section bearing ($^{\circ}$ T)

deangle - sonar depression angle

speed - CG speed (kts)

timeday - time in seconds from midnight

```

%LWAD
%
% Run a GUI to analyze LWAD 99-1 data
%
% A. Begin by selecting a ping to analyze
% The following will occur:
% (1) A map of the LWAD 99-1 exercise will be created
% showing the following:
% (a) blue cg track history, red circle is cg
% current location
% (b) red tgt track history, blue circle is tgt
% current location
% (c) ping section is shown in yellow with dashed
% yellow center
% section true bearing line. Yellow asterisks
% show 10nm range.
% (d) latitude/longitude grid lines (black dashed
% lines)
% (e) Sediment map showing Howell hook (black circles)
% with phi size approx 4-7, clay silt (black dots)
% with phi size approx 6-8, and sand
% (black slashed lines) with phi size approx 1.
% This map is based on data received from
% J. Fulford (NRL Stennis).
%
% (2) A list of ping parameters will be displayed in
% the 'LWAD Parameters' section.
%
% (3) A data analysis section will be created
% in the GUI.
%
% B. To create a contour plot press 'Contour Plot' button.
% - This plot is created by determining the
% difference between area averaged slope data and
% slope of individual beam data.
% - The plot is a filled contour plot.
% - A regular(non-filled) contour plot may be
% created by using the function 'lwad_contour.m'.
%
% Note: when the 'contour plot' button is pressed, the
% contour plot is created
% using an interval of 1 second and an overlap of
% .75. The interval/overlap is not what is selected
% in the LWAD Data Processing Program GUI. If you
% want to investigate different interval/overlap
% combinations, you'll probably want to run
% 'lwad_contourf' function separate from the LWAD

```

```

%           Data Processing Program GUI.
%
% C. To analyze beamform data
%   (1) select the type of plot(s) to display
%       - 20log|data| - is RL data in dB with averaged
%         data in red
%       - Slope - slope of RL data in blue with area
%         averaged slope in red. Dashed red
%         line is +/- 1 standard dev.
%       - STD - standard deviation in blue with area
%         averaged std in red. Dashed red line
%         is +/- 1 standard dev.
%       - Skew - Skewness in blue with area averaged
%         skewness in red. Dashed red line is
%         +/- 1 standard dev.
%       - Kurtosis - Excess Kurtosis in blue with area
%         averaged excess kurtosis in red.
%         Dashed line is +/- 1 std.
%   (2) Select the beam you would like to analyze
%       1-24(VD) or 1-72(SD)
%   (3) Select the interval and overlap to be used by
%       mmean.m, mstd.m, mskewness.m, mkurtosis.m. I
%       usually use 1 sec and .75 overlap. Other
%       combinations may be used to see the effect.
%   (4) Press 'Finish' to see the plot(s).
%   (5) Press 'Close plots' to close all plots but the
%       event map, and the LWAD GUI.
%
% D. To analyze another file press 'Browse'.
%
% E. Press 'Quit' to end your session and close all
%     open plots.
%
%     See also LWAD_CONTOUR, LWAD_CONTOURF, LWAD_MAP,
%             LWAD_POSIT, LWAD_PRM, MMEAN, MSTD, MKURTOSIS,
%             MSKEWNESS.
%
%     Created: May 8, 1999
%             David Schalm
%
%     Last Modified: July 26, 1999
%             David Schalm

menu_num = 1;
figure
load 'e:\schalm\lwad 99-1\data_drive'
lwad_menu1

```

```

%LWAD_MENU1
%
%   This will create a UI to select a file for the LWAD
%   program
%
%   See also LWAD

%   Created: April 29, 1999
%           David Schalm
%
%   Last Modified: July 26, 1999
%           David Schalm

fig = gcf;

set(fig,...
    'Units','points', ...
    'Color',[0.8 0.8 0.8], ...
    'MenuBar','none', ...
    'NumberTitle','off', ...
    'Name','LWAD Data Processing Program', ...
    'Position',[450 240 300 300], ...
    'Resize','off');
uicontrol('Units','points', ...
    'BackgroundColor',[0.8 0.8 0.8], ...
    'HorizontalAlignment','left', ...
    'Position',[10 280 180 10], ...
    'String','LWAD Data file', ...
    'FontWeight','bold', ...
    'Style','text');
h0 = uicontrol('Units','points', ...
    'BackgroundColor',[1 1 1], ...
    'HorizontalAlignment','left', ...
    'Position',[10 260 180 15], ...
    'String',[data_drive '*.mat'], ...
    'Style','edit');
callback1 = ['[data_file,data_drive] = '...
    'uigetfile(data_drive, ' ''*. *'' ');' ...
    'set(fig, ' ''Name'' ', ' ''Loading File...'' ' ...
    ');' 'if data_file == 0, load ' ...
    ''e:\schalm\lwad 99-1\data_drive'' ';'...
    'set(fig, ' ''Name'' ', ' ...
    ''LWAD Data Processing Program'' ');' ...
    ',else, lwad_menu2, end'];
uicontrol('Units','points', ...
    'Callback',callback1, ...
    'Position',[200 260 40 15], ...

```

```

    'String','Browse');
callback2 = ['ButtonName=questdlg(' ...
    '''Are you sure you want to quit?'''...
    ', ' '''Quit LWAD''' ', ' '''Yes''' ', ' ...
    '''No''' ', ' '''Yes''' ');'...
    'if length(ButtonName) == 3, close all, end'];
uicontrol('Units','points', ...
    'Callback',callback2, ...
    'Position',[10 10 40 15], ...
    'String','Quit');
uicontrol('Units','points', ...
    'BackgroundColor',[0.5 0.5 0.5], ...
    'HorizontalAlignment','left', ...
    'Position',[5 250 290 1], ...
    'String',' ', ...
    'Style','text');

```

```

%LWAD_MENU2
%
%   This will display the file parameters, and add a UI
%   section for selecting plot(s) and plot options.
%
%   Note: when the 'contour plot' button is pressed, the
%   contour plot is created using an interval of 1
%   second and an overlap of .75. The interval/overlap
%   is not what is selected in the LWAD Data Processing
%   Program GUI. If you want to investigate different
%   interval/overlap combinations, see
%   'lwad_contourf.m'. You'll probably want to run
%   'lwad_contourf' separate from the LWAD GUI.
%
%   See also LWAD, LWAD_CONTOURF
%
%   Created: April 29, 1999
%           David Schalm
%
%   Last Modified: July 26, 1999
%           David Schalm

```

```
fig = gcf;
```

```

save 'e:\schalm\lwad 99-1\data_drive.mat' data_drive
fname = [data_drive data_file];
load(fname, '-mat')
[course, speed, ctrTbrng, botdepth, deangle] = lwad_prm(fname);
[cglat, cglon, tglat, tgton] = lwad_posit(fname);
num_of_beams = size(bmf, 2);
set(h0, 'string', data_file);

```

```

uicontrol('Units','points', ...
    'BackgroundColor',[0.8 0.8 0.8], ...
    'HorizontalAlignment','left', ...
    'Position',[10 230 180 10], ...
    'String','LWAD Parameters', ...
    'FontWeight','bold', ...
    'Style','text');
uicontrol('Units','points', ...
    'BackgroundColor',[0.8 0.8 0.8], ...
    'HorizontalAlignment','left', ...
    'Position',[10 210 140 10], ...
    'String',['Ping date: ' ping_date], ...
    'Style','text');
uicontrol('Units','points', ...
    'BackgroundColor',[0.8 0.8 0.8], ...

```

```

    'HorizontalAlignment','left', ...
    'Position',[150 210 140 10], ...
    'String',['Ping Time: ' ping_time], ...
    'Style','text');

lwad_map(fname);
figure(fig)
uicontrol('Units','points', ...
    'BackgroundColor',[0.8 0.8 0.8], ...
    'HorizontalAlignment','left', ...
    'Position',[10 200 140 10], ...
    'String',['CG Position: ' num2str(cglat) 'N ' ...
        num2str(cglon) 'W'], ...
    'Style','text');
uicontrol('Units','points', ...
    'BackgroundColor',[0.8 0.8 0.8], ...
    'HorizontalAlignment','left', ...
    'Position',[150 200 140 10], ...
    'String',['TGT Position: ' num2str(tgtlat) 'N ' ...
        num2str(tgtlon) 'W'], ...
    'Style','text');
uicontrol('Units','points', ...
    'BackgroundColor',[0.8 0.8 0.8], ...
    'HorizontalAlignment','left', ...
    'Position',[10 190 140 10], ...
    'String',['CG Course(T)/Speed(kts): ' ...
        num2str(course) '/' num2str(speed)], ...
    'Style','text');
uicontrol('Units','points', ...
    'BackgroundColor',[0.8 0.8 0.8], ...
    'HorizontalAlignment','left', ...
    'Position',[150 190 140 10], ...
    'String',['Center Bearing: ' num2str(ctrTbrng)], ...
    'Style','text');
uicontrol('Units','points', ...
    'BackgroundColor',[0.8 0.8 0.8], ...
    'HorizontalAlignment','left', ...
    'Position',[10 180 140 10], ...
    'String',['Bottom Depth(fm): ' num2str(botdepth)], ...
    'Style','text');
uicontrol('Units','points', ...
    'BackgroundColor',[0.8 0.8 0.8], ...
    'HorizontalAlignment','left', ...
    'Position',[150 180 140 10], ...
    'String',['Depression Angle: ' num2str(deangle)], ...
    'Style','text');
uicontrol('Units','points', ...

```

```

    'BackgroundColor',[0.8 0.8 0.8], ...
    'HorizontalAlignment','left', ...
    'Position',[10 170 140 10], ...
    'String',['Bandwidth: ' num2str(bandwidth) ' Hz'], ...
    'Style','text');
uicontrol('Units','points', ...
    'BackgroundColor',[0.8 0.8 0.8], ...
    'HorizontalAlignment','left', ...
    'Position',[150 170 140 10], ...
    'String',['Center Freq: ' num2str(centerfreq) ...
    ' Hz'],'Style','text');
uicontrol('Units','points', ...
    'BackgroundColor',[0.8 0.8 0.8], ...
    'HorizontalAlignment','left', ...
    'Position',[10 160 140 10], ...
    'String',['Pulse length: ' num2str(pulselength) ...
    ' msec'],'Style','text');
uicontrol('Units','points', ...
    'BackgroundColor',[0.8 0.8 0.8], ...
    'HorizontalAlignment','left', ...
    'Position',[150 160 140 10], ...
    'String',['Sample rate: ' num2str(samplerate) ...
    ' Hz'],'Style','text');

% Create time vector
data_start = 1;
data_duration = length(bmf)/samplerate - (1/samplerate)...
+ data_start;
time = (data_start:1/samplerate:data_duration)';

uicontrol('Units','points', ...
    'BackgroundColor',[0.8 0.8 0.8], ...
    'HorizontalAlignment','left', ...
    'Position',[10 150 140 10], ...
    'String',['Data Duration: ' num2str(data_duration)...
    ' Sec'], ...
    'Style','text');

uicontrol('Units','points', ...
    'BackgroundColor',[0.5 0.5 0.5], ...
    'HorizontalAlignment','left', ...
    'Position',[5 140 290 1], ...
    'String',' ', ...
    'Style','text');
uicontrol('Units','points', ...
    'BackgroundColor',[0.8 0.8 0.8], ...
    'HorizontalAlignment','left', ...

```

```

    'Position',[10 120 180 10], ...
    'String',...
    'Select the plots you would like to display.', ...
    'FontWeight' , 'bold', ...
    'Style','text');
h1 = uicontrol('Units','points', ...
    'BackgroundColor',[0.8 0.8 0.8], ...
    'HorizontalAlignment','left', ...
    'Position',[10 100 60 10], ...
    'String','20 log |data|', ...
    'Style', 'checkbox');
h2 = uicontrol('Units','points', ...
    'BackgroundColor',[0.8 0.8 0.8], ...
    'HorizontalAlignment','left', ...
    'Position',[10 85 60 10], ...
    'String','Slope', ...
    'Style', 'checkbox');
h3 = uicontrol('Units','points', ...
    'BackgroundColor',[0.8 0.8 0.8], ...
    'HorizontalAlignment','left', ...
    'Position',[10 70 60 10], ...
    'String','STD', ...
    'Style', 'checkbox');
h4 = uicontrol('Units','points', ...
    'BackgroundColor',[0.8 0.8 0.8], ...
    'HorizontalAlignment','left', ...
    'Position',[10 40 60 10], ...
    'String','Kurtosis', ...
    'Style', 'checkbox');
h5 = uicontrol('Units','points', ...
    'BackgroundColor',[0.8 0.8 0.8], ...
    'HorizontalAlignment','left', ...
    'Position',[10 55 60 10], ...
    'String','Skew', ...
    'Style', 'checkbox');
uicontrol('Units','points', ...
    'BackgroundColor',[0.8 0.8 0.8], ...
    'HorizontalAlignment','left', ...
    'Position',[85 100 65 10], ...
    'String','Beam Selection:', ...
    'Style','text');
beam = {1:1:num_of_beams};
h6 = uicontrol('Units','points', ...
    'HorizontalAlignment','left', ...
    'BackgroundColor',[1 1 1], ...
    'Position',[85 40 65 55], ...
    'String',beam, ...

```

```

        'Style','listbox', ...
        'ListBoxTop', 1);
uicontrol('Units','points', ...
    'BackgroundColor',[0.8 0.8 0.8], ...
    'HorizontalAlignment','left', ...
    'Position',[160 100 65 10], ...
    'String','Interval (sec)', ...
    'Style', 'text');
interval_sel = {.5 1 2};
h7 = uicontrol('Units','points', ...
    'BackgroundColor',[1 1 1], ...
    'HorizontalAlignment','left', ...
    'Position',[160 40 60 55], ...
    'String',interval_sel, ...
    'Style', 'listbox');
uicontrol('Units','points', ...
    'BackgroundColor',[0.8 0.8 0.8], ...
    'HorizontalAlignment','left', ...
    'Position',[230 100 65 10], ...
    'String','Overlap (0-1)', ...
    'Style', 'text');
overlap_sel = {0 .25 .5 .75};
h8 = uicontrol('Units','points', ...
    'BackgroundColor',[1 1 1], ...
    'HorizontalAlignment','left', ...
    'Position',[230 40 60 55], ...
    'String',overlap_sel, ...
    'Style', 'listbox');
callback4 = ['set(fig, ' "'Name'" ', ' ...
    "'Getting Contour Plot...'" ');'...
    'lwad_contourf(fname,1,.75);'...
    'set(fig, ' "'Name'" ', ' ...
    "'LWAD Data Processing Program'" ');'];
uicontrol('Units','points', ...
    'Callback', callback4, ...
    'Position',[80 10 60 15], ...
    'String','Contour Plot');
callback3 = ['set(fig, ' "'Name'" ', ' ...
    "'Getting Plots...'" ');'...
    'lwad_menu3'];
uicontrol('Units','points', ...
    'Callback', callback3, ...
    'Position',[250 10 40 15], ...
    'String','Finish');
set(fig,'Name','LWAD Data Processing Program')

```

```

%LWAD_MENU3
%
%   This script file is used to create the selected plots.
%
%   See also LWAD

%   Created: April 29, 1999
%           David Schalm
%
%   Last Modified: July 26, 1999
%           David Schalm

beam_selection = beam{1}(get(h6,'value'));
data_file = get(h0,'string');
interval = interval_sel{get(h7,'value')};
overlap = overlap_sel{get(h8,'value')};
spacing = interval - interval*overlap;
N = round(interval*samplerate);

% Create time vector
[mtime,ao] = mmean(time,N,overlap);
if ao ~= overlap
    overlap = ao;
    disp(['Note: actual overlap is ' num2str(ao)]);
end

%%%%%%%% P L O T   T H E   D A T A   %%%%%%%%%%%%%%%
% Display plots of data/mean, slope, kurtosis, skewness

if data_file(5:6) == 'SD'
    area_stats_fname = ['e:\schalm\lwad 99-1\area_stats\'...
        data_file(5:6) '_stats' ...
        num2str(interval) '.mat'];
else
    area_stats_fname = ['e:\schalm\lwad 99-1\area_stats\'...
        data_file(19:20) '_stats' ...
        num2str(interval) '.mat'];
end

load(area_stats_fname)

if get(h8,'value') == 1
    area_stats = stats_0;
elseif get(h8,'value') == 2
    area_stats = stats_25;
elseif get(h8,'value') == 3
    area_stats = stats_5;

```

```

elseif get(h8,'value') == 4
    area_stats = stats_75;
end

log_data = 20*log10(abs(bmf(:,beam_selection)));
thetal = ctrTbrng - num_of_beams*5/2 + 5/2;
theta = thetal + 5*(beam_selection - 1);
if theta < 0, theta = theta + 360; end

title_string = ['Ping: ' data_file(14:16) ', Mode: SD' ...
    ', Beam: ' num2str(beam_selection)...
    ', Brng(T): ' num2str(theta) ...
    ', Interval: ' num2str(interval) ', Overlap: ' ...
    num2str(overlap)];

% plot 20log|data|
if get(h1,'value') == 1
    figure, b = gcf;
    plot(time,log_data,'k'), title(title_string),
    ylabel('Reverberation Level (dB)'), xlabel('Time (sec)')
    axis([0 data_duration 0 150]), grid on, hold on
    [mean_data] = mmean(log_data,N,overlap);
    plot(mtime,mean_data,'w')
end

% plot the slope of 20log|data|
if get(h2,'value') == 1
    figure, b = gcf;
    [mean_data] = mmean(log_data,N,overlap);
    slope_data = gradient(mean_data);
    plot(mtime,slope_data/spacing,'k*-'),title(title_string)
    ylabel('RL Slope'),xlabel('Time (sec)'),grid on, hold on
    plot(mtime, area_stats(1,:)/spacing,'k')
    plot(mtime, (area_stats(1,:)-area_stats(2,:))/...
        spacing,'--k')
    plot(mtime, (area_stats(1,:)+area_stats(2,:))/...
        spacing,'--k')
    legend(['Beam ' num2str(beam_selection)...
        ' Slope'],'Average Slope','Average Slope STD')
end

% detrend the data w/ a 3rd order polynomial
log_data = log_data-polyval(polyfit(time,log_data,3),time);

% Plot the STD
if get(h3,'value') == 1
    figure, b = gcf;

```

```

    [std_data] = mstd(log_data,N,overlap);
    plot(mtime,std_data,'k*-'), title(title_string)
    ylabel('STD'), xlabel('Time (sec)')
    grid on, hold on
    plot(mtime, area_stats(3,:), 'k')
    plot(mtime, (area_stats(3,:)-area_stats(4,:)), '--k')
    plot(mtime, (area_stats(3,:)+area_stats(4,:)), '--k')
    legend(['Beam ' num2str(beam_selection) ' STD'],...
           'Average STD', 'STD of Average STD')
end

% Plot the Kurtosis
if get(h4, 'value') == 1
    figure, b = gcf;
    [kurtosis_data] = mkurtosis(log_data,1,N,overlap);
    plot(mtime,kurtosis_data,'k*-'), title(title_string)
    ylabel('Kurtosis'), xlabel('Time (sec)')
    grid on, hold on
    plot(mtime, area_stats(7,:), 'k')
    plot(mtime, (area_stats(7,:)-area_stats(8,:)), '--k')
    plot(mtime, (area_stats(7,:)+area_stats(8,:)), '--k')
    legend(['Beam ' num2str(beam_selection) ' Kurtosis'],...
           'Average Kurtosis', 'STD of Average Kurtosis')
end

% Plot the Skew
if get(h5, 'value') == 1
    figure, b = gcf;
    [skew_data] = mskewness(log_data,N,overlap);
    plot(mtime,skew_data,'k*-'), title(title_string)
    ylabel('Skew'), xlabel('Time (sec)')
    grid on, hold on
    plot(mtime, area_stats(5,:), 'k')
    plot(mtime, (area_stats(5,:)-area_stats(6,:)), '--k')
    plot(mtime, (area_stats(5,:)+area_stats(6,:)), '--k')
    legend(['Beam ' num2str(beam_selection) ' Skew'],...
           'Average Skew', 'STD of Average Skew')
end

set(fig, 'Name', 'LWAD Data Processing Program')
figure(fig)
uicontrol('Units', 'points', ...
          'Callback', ['closebut([fig 100])'], ...
          'Position', [165 10 60 15], ...
          'String', 'Close Plots');

```

```

function [area_stats] = lwad_stats(file_type,interval...
,overlap)
%LWAD_STATS Determine the statistics for the LWAD 99-1
% exercise area.
% [AREA_STATS,ERROR_LOG] = LWAD_STATS(FILE_TYPE,
% INTERVAL,OVERLAP) will return the statistics for the
% selected parameters. The function will calculate
% statistics for each individual beam, average these
% statistics, and determine the standard deviation.
%
% FILE_TYPE is either 'sd', 'cp', or 'cw' ... depending
% on which mode you want to analyze.
%
% INTERVAL and OVERLAP are required by funtions MMEAN,
% MSKEWNESS, and MKURTOSIS to calculate the respective
% statistics. If no INTERVAL or OVERLAP are specified,
% the program defaults to INTERVAL = 1, OVERLAP = .75.
%
% The mean and std for the following statistics are
% determined:
%     (1) Slope
%     (2) STD
%     (3) Skewness
%     (4) Excess Kurtosis
%
% Note: STD, Skewness, and Excess Kurtosis are determined
% from 'detrended' data. The data is detrended by
% subtracting a best fit 3rd order polynomial from
% the data. Slope is not detrended.
%
% The output file AREA_STATS is organized as such:
%     Row 1: mean of the slope
%     Row 2: std of the slope
%     Row 3: mean of the std
%     Row 4: std of the std
%     Row 5: mean of the skewness
%     Row 6: std of the skewness
%     Row 7: mean of the kurtosis
%     Row 8: std of the kurtosis
%
% The number of columns will be a function of the
% selected INTERVAL and OVERLAP.
%
% If the time series data contains a zero value this will
% cause errors in the statistics because log(0) = -inf.
% All beams which contain a zero value are discarded.
% An error log may be obtained as an output.

```

```

% Created: May 25, 1999
% David Schalm
%
% Last Modified: May 25, 1999
% David Schalm

load data_drive
drive_num = data_drive(1);

if nargin == 0
    file_type = input('Select file type (sd,cp,cw)...');
end

if file_type == 'sd'
    filepath = {[drive_num ...
                ':\LWAD 99-1 Data\Tape 17\sd\' ] ...
                [drive_num ':\LWAD 99-1 Data\Tape 18\sd\' ]};
elseif file_type == 'cp'
    filepath = {[drive_num ...
                ':\LWAD 99-1 Data\Tape 17\vd\cp\' ] ...
                [drive_num ':\LWAD 99-1 Data\Tape 18\vd\cp\' ]};
elseif file_type == 'cw'
    filepath = {[drive_num ...
                ':\LWAD 99-1 Data\Tape 17\vd\cw\' ] ...
                [drive_num ':\LWAD 99-1 Data\Tape 18\vd\cw\' ]};
end

row_index = 0;
error_index = 0;

for b = 1:1:2
    clear fname
    D = dir(char(filepath(b)));
    [fname{1:length(D)}] = deal(D.name);

    % get rid of '.' and '..' filenames
    fname = fname(3:length(fname));

    for m = 1:1:length(fname)
        load([char(filepath(b)) char(fname(m))])
        disp(['Current file is ' filepath{b} fname{m}])
        X = (1:1:length(bmf))';
        N = round(samplerate*interval);
        num_of_beams = size(bmf,2);

        % Create time vector

```

```

    data_start = 1;
    data_duration = length(bmf)/samplerate -
(1/samplerate)...
    + data_start;
    time = (data_start:1/samplerate:data_duration)';
    [mtime,ao] = mmean(time,N,overlap);

    for n = 1:1:num_of_beams

        % Skip over data with 0 values --> cause errors
        % in statistics
        if sum(bmf(:,n) == 0) > 0
        else

            row_index = row_index + 1;

            % Calculate amplitude of data (dB)
            log_data = 20*log10(abs(bmf(:,n)));

            mean_data = mmean(log_data,N,overlap);
            lwad_stats_slope(row_index,:) = ...
                gradient(mean_data);

            % Detrend the data
            data = log_data - ...
                polyval(polyfit(X,log_data,3),X);

            lwad_stats_std(row_index,:) = ...
                mstd(data,N,overlap);
            lwad_stats_skewness(row_index,:) = ...
                mskewness(data,N,overlap);
            lwad_stats_kurtosis(row_index,:) = ...
                mkurtosis(data,1,N,overlap);
        end
    end
end
end
end

[M,N] = size(lwad_stats_slope);

lwad_stats_slope((M+1),:) = mean(lwad_stats_slope);
lwad_stats_slope((M+2),:) = std(lwad_stats_slope(1:M,:));

lwad_stats_std((M+1),:) = mean(lwad_stats_std);
lwad_stats_std((M+2),:) = std(lwad_stats_std(1:M,:));

lwad_stats_skewness((M+1),:) = mean(lwad_stats_skewness);

```

```
lwad_stats_skewness((M+2),:) = ...
    std(lwad_stats_skewness(1:M,:));

lwad_stats_kurtosis((M+1),:) = mean(lwad_stats_kurtosis);
lwad_stats_kurtosis((M+2),:) = ...
    std(lwad_stats_kurtosis(1:M,:));

area_stats(1:2,:) = lwad_stats_slope((M+1):(M+2),:);
area_stats(3:4,:) = lwad_stats_std((M+1):(M+2),:);
area_stats(5:6,:) = lwad_stats_skewness((M+1):(M+2),:);
area_stats(7:8,:) = lwad_stats_kurtosis((M+1):(M+2),:);
```

```

function [y,actual_overlap] = mmean(x,N,overlap)
%MMEAN   Moving mean value.
%   MMEAN(x,N,overlap) should be used to calculate a "moving
%   average" where N is the number of points to use for each
%   interval, and OVERLAP is the ammount of overlap to use.
%   In some cases an assigned overlap may not result in an
%   integer value for STEP (i.e. number of points to advance
%   after each calculation).  In this case, OVERLAP will be
%   rounded to the nearest value which will result in an
%   integer value for STEP.  The ACTUAL_OVERLAP can be
%   displayed if desired.
%
%   See also MEAN, MSTD, MKURTOSIS, MSKEWNESS, LWAD.

%   Created: May 8, 1999
%           David Schalm
%
%   Last Modified: July 26, 1999
%           David Schalm

if nargin == 2
    overlap = 0;
end

step = round((1-overlap)*N); % Number of points to advance

i = 1;
while (N+(i-1)*step) <= length(x)
    y(i) = mean(x((1+(i-1)*step):(N+(i-1)*step)));
    i = i + 1;
end

if nargin == 2
    actual_overlap = 1-(step/N);
end

```

```

function [y,actual_overlap] = mstd(x,N,overlap)
%MSTD Moving standard deviation
%
% MSTD(x,N,overlap) should be used to calculate a "moving
% std" where N is the number of points to use for each
% interval, and OVERLAP is the ammount of overlap to use.
% In some cases an assigned overlap may not result in an
% integer value for STEP (i.e. number of points to advance
% after each calculation). In this case, OVERLAP will be
% rounded to the nearest value which will result in an
% integer value for STEP. The ACTUAL_OVERLAP can be
% displayed if desired.
%
% See also MEAN, MEDIAN, STD, MIN, MAX, COV, LWAD.
%
% Created: May 8, 1999
%         David Schalm
%
% Last Modified: July 26, 1999
%         David Schalm

if nargin == 2
    overlap = 0;
end

step = round((1-overlap)*N); % Number of points to advance
i = 1;
while (N+(i-1)*step) <= length(x)
    y(i) = std(x((1+(i-1)*step):(N+(i-1)*step)));
    i = i + 1;
end

if nargin == 2
    actual_overlap = 1-(step/N);
end

```

```

function [s,actual_overlap] = mskewness(x,N,overlap)
%MSKEWNESS Moving Skewness.
% MSKEWNESS(x,N,overlap) should be used to calculate a
% "moving skewness" where N is the number of points to use
% for each interval, and OVERLAP is the ammount of overlap
% to use. In some cases an assigned overlap may not
result
% in an integer value for STEP (i.e. number of points to
% advance after each calculation). In this case, OVERLAP
% will be rounded to the nearest value which will result
% in an integer value for STEP. The ACTUAL_OVERLAP can be
% displayed if desired.
%
% See also SKEWNESS, MMEAN, MSTD, MKURTOSIS, LWAD.

% Created: May 8, 1999
% David Schalm
%
% Last Modified: July 26, 1999
% David Schalm

if nargin == 2
    overlap = 0;
end

step = round((1-overlap)*N); % Number of points to advance
i = 1;
while (N+(i-1)*step) <= length(x)
    s(i) = skewness(x((1+(i-1)*step):(N+(i-1)*step)));
    i = i + 1;
end

if nargout == 2
    actual_overlap = 1-(step/N);
end

```

```

function [k,actual_overlap] = mkurtosis(x,flag,N,overlap)
%MKURTOSIS Moving Kurtosis.
% MKURTOSIS(x,flag,N,overlap) should be used to calculate
% a "moving kurtosis" where N is the number of points to
% use for each interval, and OVERLAP is the ammount of
% overlap to use. In some cases an assigned overlap may
% not result in an integer value for STEP (i.e. number of
% points to advance after each calculation). In this
% case, OVERLAP will be rounded to the nearest value
% which will result in an integer value for STEP. The
% ACTUAL_OVERLAP can be displayed if desired.
%
% MKURTOSIS(x,1,N,overlap) calculates excess kurtosis.
%
% See also KURTOSIS, MSTD, MSKEWNESS, MMEAN, LWAD.

% Created: May 8, 1999
% David Schalm
%
% Last Modified: July 26, 1999
% David Schalm

if nargin == 3
    overlap = 0;
end

step = round((1-overlap)*N); % Number of points to advance
i = 1;
while (N+(i-1)*step) <= length(x)
    if flag == 1
        k(i) = kurtosis(x((1+(i-1)*step):(N+(i-1)*step))) - 3;
    else
        k(i) = kurtosis(x((1+(i-1)*step):(N+(i-1)*step)));
    end
    i = i + 1;
end

if nargin == 2
    actual_overlap = 1-(step/N);
end

```

```

function [cglatout,cglonout,tgtlatout,tgtlonout] = ...
    lwad_posit(data_file)
%LWAD_POSIT
%   Determine the coordinates of the DD (lat/lon) based on
%   the ping time.
%
%   See also LWAD

%   Created: May 15, 1999
%           David Schalm
%
%   Last Modified: July 26, 1999
%           David Schalm

load(data_file,'-mat')
load evt31.mat
ref_time = str2num(ping_time(1:2))*3600 + ...
    str2num(ping_time(4:5))*60 + str2num(ping_time(7:8));

i = 1;
while evt31_time(i) <= ref_time
    i = i + 1;
end

interp_factor = (evt31_time(i) - ref_time)/60;
cglatout = cg_lat(i) - (cg_lat(i) - cg_lat(i-1))*...
    interp_factor;
cglonout = cg_lon(i) - (cg_lon(i) - cg_lon(i-1))*...
    interp_factor;
tgtlatout = tgt_lat(i) - (tgt_lat(i) - tgt_lat(i-1))*...
    interp_factor;
tgtlonout = tgt_lon(i) - (tgt_lon(i) - tgt_lon(i-1))*...
    interp_factor;

```

```

function [course,speed,ctrbrng,botdepth,deangle] = ...
    lwad_prm(data_file)
%LWAD_PRM
%   This function will access the parameter file
%   'evt31prm.mat' to determine the ping parameters
%   associated with the selected data file.
%
%   course:  ships course in degrees True
%   speed:   ships speed in knots
%   ctrbrng: center of ping section in degrees True
%   botdepth: bottom depth in fathoms
%   deangle: sonar depression angle in degrees
%
%   See also LWAD

%   Created: May 11, 1999
%           David Schalm
%
%   Last Modified: July 26, 1999
%           David Schalm

load(data_file,'-mat')
load evt31prm.mat
ref_time = str2num(ping_time(1:2))*3600 + ...
    str2num(ping_time(4:5))*60 + str2num(ping_time(7:8));

i = 1;
while timeday(i) < ref_time
    i = i + 1;
end
i = i-1;

course = course(i);
speed = speed(i);
ctrbrng = ctrbrng(i);
botdepth = botdepth(i);
deangle = deangle(i);

```

```

function lwad_map(fname)
%LWAD_MAP
%   Create a map of the exercise area
%   (1) A map of the LWAD 99-1 exercise will be created
%       showing the following:
%       (a) blue cg track history, red circle is cg
%           current location
%       (b) red tgt track history, blue circle is tgt
%           current location
%       (c) ping section is shown in yellow with dashed
%           yellow center section true bearing line.
%           Yellow asterisks show 10nm range.
%       (d) latitude/longitude grid lines (black dashed
%           lines)
%       (e) Sediment map showing hal hook (black circles)
%           with phi size approx 4-7, clay silt (black dots)
%           with phi size approx 6-8, and sand
%           (black slashed lines) with phi size approx 1.
%           This map is based on data received from
%           J. Fulford (NRL Stennis).
%
%   If no filename is specified, a gui will open to allow
%   the user to select a file.
%
%   See also LWAD
%
%   Created: May 15, 1999
%           David Schalm
%
%   Last Modified: July 26, 1999
%           David Schalm

if nargin == 0
    load data_drive
    [filename,pathname] = uigetfile([data_drive]);
    fname = [pathname filename];
    data_drive = pathname;
    save 'e:\schalm\lwad 99-1\data_drive.mat' data_drive
end

load(fname, '-mat')
[cglat,cglon,tgtlat,tgtlon] = lwad_posit(fname);
[course,speed,ctrTbrng,botdepth,deangle] = lwad_prm(fname);
load evt31.mat;
num_of_beams = size(bmf,2);

figure(100)

```

```

clf
set(100,...
    'NumberTitle', 'off', ...
    'Name','LWAD 99-1 Event 31');

% Plot the sediment
pic = imread('florida','bmp');
sed_lon = linspace(-84.5,-83.9,600);
sed_lat = linspace(25.4,25.9,600);
image(sed_lon,sed_lat,pic);
hold on, grid on, axis xy

%plot cg and tgt track history
plot(-cg_lon,cg_lat), hold on
xlabel('Longitude (W)'), ylabel('Latitude (N)')
title(['LWAD 99-1 Event 31']), axis equal, axis image
plot(-cglon,cglat,'ro')
plot(-tgt_lon,tgt_lat,'r')
plot(-tgtlon,tgtlat,'bo')

% Plot a 10nm range circle, and ctr bearing line
theta_one = ctrTbrng - num_of_beams*5/2;
theta = theta_one:5:(theta_one+(num_of_beams-1)*5);
theta(num_of_beams+1) = theta_one;

for i = 1:1:(num_of_beams+1)
    circle_lat(i) = cglat + 10*cos(theta(i)*pi/180)/60;
    circle_lon(i) = -(cglon - 10*sin(theta(i)*pi/180)/...
        (60*cos(cglat*pi/180)));
end

if num_of_beams == 24
    plot(circle_lon,circle_lat,'y*')
    plot([-cglon circle_lon(13)],...
        [cglat circle_lat(13)], '--y')
    circle_lat = [cglat circle_lat(1:24) cglat];
    circle_lon = [-cglon circle_lon(1:24) -cglon];
    plot(circle_lon,circle_lat,'y')
else
    plot(circle_lon,circle_lat,'y*')
    plot([-cglon circle_lon((num_of_beams/2) + 1)],...
        [cglat circle_lat((num_of_beams/2) + 1)], '--y')
    plot(circle_lon,circle_lat,'y')
end
end

```

```

function [cout] = lwad_contour(fname,interval,overlap)
%LWAD_CONTOUR
%   Create a sediment contour based on the selected ping.
%
%   This plot is created by determining the difference
%   between area averaged slope data and slope of
%   individual beam data.
%
%   If no filename, interval, or overlap are specified, a
%   gui will open to allow the user to select a file.
%   The interval and overlap will default to 1 sec and
%   .75.  Modify this file in order to change the
%   defaults.
%
%   The plot shows the cg current position (black circle),
%   target current position (red circle), and exercise
%   area (black dashed lines).
%
%   This function uses code from the Matlab function
%   'contour.m'
%
%   See also LWAD_CONTOURF, CONTOUR, LWAD.
%
%   Created: May 15, 1999
%           David Schalm
%
%   Last Modified: July 26, 1999
%           David Schalm

if nargin == 0
    load data_drive
    [filename,pathname] = uigetfile([data_drive '*.*']);
    fname = [pathname filename];
    data_drive = pathname;
    save 'e:\schalm\lwad 99-1\data_drive.mat' data_drive

    %%%%%% Default values %%%%%%
    interval = 1;
    overlap = .75;
    spacing = interval - interval*overlap;
    %interval = input('What is the interval (.5,1,2): ');
    %overlap = input('What is the overlap (0,.25,.5,.75): ');
    %%%%%%%%%%%%%%%

else
    if fname((length(fname)-2):length(fname)) == 'mat'
        filename = fname((length(fname)-23):length(fname));

```

```

        else
            filename = fname((length(fname)-19):length(fname));
        end
    end
end

% Load the data file
load(fname, '-mat')
[cglat, cglon, tglat, tglon] = lwad_posit(fname);
[course, speed, ctrTbrng, botdepth, deangle] = lwad_prm(fname);

if filename(5:6) == 'SD' | filename(5:6) == 'sd'
    file_type = filename(5:6);
else
    file_type = filename(19:20);
end

% Load the average statistics
area_stats_fname = ['e:\schalm\lwad 99-1\area_stats\' ...
    file_type '_stats' num2str(interval) '.mat'];
load(area_stats_fname)
if overlap == 0
    area_stats = stats_0;
elseif overlap == .25
    area_stats = stats_25;
elseif overlap == .5
    area_stats = stats_5;
else
    area_stats = stats_75;
end

% Create time\range vector
sound_speed = .81; %nm/s
N = round(interval*samplerate);
data_start = 1;
data_duration = length(bmf)/samplerate - (1/samplerate)...
    + data_start;
time = (data_start:1/samplerate:data_duration)';
[mtime, ao] = mmean(time, N, overlap);
mrange = sound_speed*mtime/2;

% Create bearing vector
num_of_beams = size(bmf, 2);
theta_one = ctrTbrng - num_of_beams*5/2 + 5/2;
theta = theta_one:5:(theta_one+(num_of_beams-1)*5);

index = 0;
for i = 1:1:num_of_beams

```

```

if sum(bmf(:,i) == 0) > 0
    % skip this beam
else
    log_data = 20*log10(abs(bmf(:,i)));
    index = index + 1;
    theta1(index) = theta(i);
    mean_data = mmean(log_data,N,overlap);
    slope_data = (gradient(mean_data));
    diff_data(index,:) = slope_data - area_stats(1,:);
end
end

c1 = contourc(mrange,theta1,diff_data);

i = 1;
while i < length(c1)
    nexti = i + c1(2,i);
    c_new(:,i) = c1(:,i);

    % convert range/brng to lat/lon
    for k = (i+1):1:nexti
        c_new(1,k) = -(cglon - sin(c1(2,k)*pi/180)*...
            c1(1,k)/(60*cos(cglat*pi/180)));
        c_new(2,k) = cglat + cos(c1(2,k)*pi/180)*...
            c1(1,k)/60;
    end
    i = nexti + 1;
end
c = c_new;

figure
lims = [-84.4 -84 25.5 25.8];

colortab = get(newplot,'colororder');
[mc,nc] = size(colortab);

% Create the plot
newplot;
if ~ishold
    view(3); grid on
    set(gca,'xlim',lims(1:2),'ylim',lims(3:4))
end

limit = size(c,2);
i = 1;
h = [];
color_h = [];

```

```

while(i < limit)
    z_level = c(1,i);
    npoints = c(2,i);
    nexti = i+npoints+1;

    xdata = c(1,i+1:i+npoints);
    ydata = c(2,i+1:i+npoints);
    zdata = z_level + 0*xdata; % Make zdata the same size
                                % as xdata

    % Create the patches or lines
    cu = patch('XData',[xdata NaN],'YData',[ydata NaN], ...
              'ZData',[zdata NaN],'CData',[zdata NaN], ...
              'facecolor','none','edgecolor','flat',...
              'userdata',z_level);
    h = [h; cu(:)];
    color_h = [color_h ; z_level];
    i = nexti;
end

for i = 1:length(h)
    set(h(i),'Zdata',[]);
end

view(2);
set(gca,'box','on');

axis equal, grid on, zoom on, hold on
axis([-84.5 -83.9 25.4 25.9])
xlabel('Longitude (W)'), ylabel('Latitude (N)')
warning off
title(['Event 31/' filename(13:16) ', ' ...
      ping_date ', ' ping_time])
caxis([-12 12])
colorbar
plot(-cglon,cglat,'ko')
plot(-tgtlon,tgtlat,'ro')

% Plot cg box
plot([-84.27 -84.27 -84.11 -84.11 -84.27],...
     [25.61 25.71 25.71 25.61 25.61],'k--')
zoom on
brighten(1)

if nargout > 0
    cout = c;
end

```

```

function [cout] = lwad_contourf(fname,interval,overlap)
%LWAD_CONTOURF
%   Create a filled sediment contour based on the selected
%   ping.
%
%   This plot is created by determining the difference
%   between area averaged slope data and slope of
%   individual beam data.
%
%   If no filename, interval, or overlap are specified, a
%   gui will open to allow the user to select a file.
%   The interval and overlap will default to 1 sec and
%   .75. Modify this file in order to change the
%   defaults.
%
%   The plot shows the cg current position (black circle),
%   target current position (red circle), and exercise
%   area (black dashed lines).
%
%   This function uses code from the Matlab function
%   'contourf.m'
%
%   See also LWAD_CONTOUR, CONTOURF, LWAD.
%
%   Created: May 15, 1999
%           David Schalm
%
%   Last Modified: July 26, 1999
%           David Schalm

if nargin == 0
    load data_drive
    [filename,pathname] = uigetfile([data_drive '*.*']);
    fname = [pathname filename];
    data_drive = pathname;
    save 'e:\schalm\lwad 99-1\data_drive.mat' data_drive

    %%%%% Default values %%%%%
    interval = 1;
    overlap = .75;
    %interval = input('What is the interval (.5,1,2): ');
    %overlap = input('What is the overlap (0,.25,.5,.75): ');
    %%%%%%%%%%%%%%%

else
    if fname((length(fname)-2):length(fname)) == 'mat'
        filename = fname((length(fname)-23):length(fname));

```

```

    else
        filename = fname((length(fname)-19):length(fname));
    end
end

% Load the data file
load(fname, '-mat')
[cglat, cglon, tgtlat, tgtlon] = lwad_posit(fname);
[course, speed, ctrTbrng, botdepth, deangle] = lwad_prm(fname);
spacing = interval - interval*overlap;

if filename(5:6) == 'SD' | filename(5:6) == 'sd'
    file_type = filename(5:6);
else
    file_type = filename(19:20);
end

% Load the average statistics
area_stats_fname = ['e:\schalm\lwad 99-1\area_stats\' ...
    file_type '_stats' num2str(interval) '.mat'];
load(area_stats_fname)
if overlap == 0
    area_stats = stats_0;
elseif overlap == .25
    area_stats = stats_25;
elseif overlap == .5
    area_stats = stats_5;
else
    area_stats = stats_75;
end

% Create time\range vector
sound_speed = .81; %nm/s
N = round(interval*samplerate);
data_start = 1;
data_duration = length(bmf)/samplerate - (1/samplerate)...
    + data_start;
time = (data_start:1/samplerate:data_duration)';
[mtime, ao] = mmean(time, N, overlap);
mrange = sound_speed*mtime/2;

% Create bearing vector
num_of_beams = size(bmf, 2);
theta_one = ctrTbrng - num_of_beams*5/2 + 5/2;
theta = theta_one:5:(theta_one+(num_of_beams-1)*5);

```

```

index = 0;
for i = 1:1:num_of_beams
    if sum(bmf(:,i) == 0) > 0
        % skip beams w/ bad data
    else
        log_data = 20*log10(abs(bmf(:,i)));
        index = index + 1;
        thetal(index) = theta(i);
        mean_data = mmean(log_data,N,overlap);
        slope_data = (gradient(mean_data));
        diff_data(index,:) = (slope_data - area_stats(1,:));
    end
end

diff_data = diff_data/spacing;

lin = '';
col = '';
x = mrange;
y = thetal;
z = diff_data;
nv = [];
%nv = 4;
if (size(y,1)==1), y=y'; end;
if (size(x,2)==1), x=x'; end;
[mz,nz] = size(z);
lims = [-84.4 -84 25.5 25.8];

i = find(isfinite(z));
minz = min(z(i));
maxz = max(z(i));

if length(nv) <= 1
    if isempty(nv)
        CS=contourc([minz maxz ; minz maxz]);
    else
        CS=contourc([minz maxz ; minz maxz],nv);
    end

    % Find the levels
    ii = 1;
    nv = minz; % Include minz so that the contours are
    %totally filled
    while (ii < size(CS,2)),
        nv=[nv CS(1,ii)];
        ii = ii + CS(2,ii) + 1;
    end
end

```

```

end

% Don't fill contours below the lowest level specified in
% nv. To fill all contours, specify a value of nv lower
% than the minimum of the surface.
draw_min=0;
if any(nv <= minz),
    draw_min=1;
end

% Get the unique levels
nv = sort([minz nv(:)']);
zi = [1, find(diff(nv))+1];
nv = nv(zi);

% Surround the matrix by a very low region to get closed
% contours, and replace any NaN with low numbers as well.

zz=[ repmat(NaN,1,nz+2) ; repmat(NaN,mz,1) z ...
      repmat(NaN,mz,1) ; repmat(NaN,1,nz+2)];
kk=find(isnan(zz(:)));
zz(kk)=minz-1e4*(maxz-minz)+zeros(size(kk));

xx = [2*x(:,1)-x(:,2), x, 2*x(:,nz)-x(:,nz-1)];
yy = [2*y(1,:)-y(2,:); y; 2*y(mz,:)-y(mz-1,:)];
if (min(size(yy))==1),
    [CS,msg]=contours(xx,yy,zz,nv);
else
    [CS,msg]=contours(xx([ 1 1:mz mz],:),yy(:,[1 1:nz nz])...
        ,zz,nv);
end;
if ~isempty(msg), error(msg); end

c_new = [];
i = 1;
while i < length(CS)
    nexti = i + CS(2,i);
    c_new(:,i) = CS(:,i);

    % convert range/brng to lat/lon
    for k = (i+1):1:nexti
        c_new(1,k) = -(cglon - sin(CS(2,k)*pi/180)*...
            CS(1,k)/(60*cos(cglat*pi/180)));
        c_new(2,k) = cglat + cos(CS(2,k)*pi/180)*...
            CS(1,k)/60;
    end
    i = nexti + 1;

```

```

end
CS = c_new;

figure

% Find the indices of the curves in the c matrix, and get
% the area of closed curves in order to draw patches
% correctly.
ii = 1;
ncurves = 0;
I = [];
Area=[];
while (ii < size(CS,2)),
    nl=CS(2,ii);
    ncurves = ncurves + 1;
    I(ncurves) = ii;
    xp=CS(1,ii+(1:nl)); % First patch
    yp=CS(2,ii+(1:nl));
    Area(ncurves)=sum( diff(xp).*(yp(1:nl-1)+yp(2:nl))/2 );
    ii = ii + nl + 1;
end

newplot;
if ~ishold,
    view(2);
    set(gca,'xlim',lims(1:2),'ylim',lims(3:4))
end

% Plot patches in order of decreasing size. This makes sure
% that all the levels get drawn, not matter if we are going
% up a hill or down into a hole. When going down we shift
% levels though, you can tell whether we are going up or
% down by checking the sign of the area (since curves are
% oriented so that the high side is always the same side).
% Lowest curve is largest and encloses higher data always.

H=[];
[FA,IA]=sort(-abs(Area));
if ~isstr(get(gca,'color')),
    bg = get(gca,'color');
else
    bg = get(gcf,'color');
end
if isempty(col)
    edgec = get(gcf,'defaultsurfaceedgecolor');
else
    edgec = col;

```

```

end
if isempty(lin)
    edgestyle = get(gcf,'defaultpatchlinestyle');
else
    edgestyle = lin;
end
for jj=IA,
    nl=CS(2,I(jj));
    lev=CS(1,I(jj));
    if (lev ~=minz | draw_min ),
        xp=CS(1,I(jj)+(1:nl));
        yp=CS(2,I(jj)+(1:nl));
        if (sign(Area(jj)) ~=sign(Area(IA(1))) ),
            kk=find(nv==lev);
            if (kk>1+sum(nv<=minz)*(~draw_min)),
                lev=nv(kk-1);
            else
                lev=NaN;          % missing data section
            end;
        end;
    end;

    if (isfinite(lev)),
        H=[H;patch(xp,yp,lev,'facecolor','flat',...
            'edgecolor',edgex,'linestyle',edgestyle)];
    else
        H=[H;patch(xp,yp,lev,'facecolor',bg,...
            'edgecolor',edgex,'linestyle',edgestyle)];
    end;
end;
end;
end;

numPatches = length(H);
if numPatches>1
    for i=1:numPatches
        set(H(i), 'faceoffsetfactor', 0, ...
            'faceoffsetbias', (1e-3)+(numPatches-i)/...
            (numPatches-1)/30);
    end
end

% Set the plot options
axis equal, grid on, zoom on, hold on
axis([-84.5 -83.9 25.4 25.9])
xlabel('Longitude (W)'), ylabel('Latitude (N)')
warning off
title(['Ping:' filename(13:16) ...
    ',Mode: SD, Interval: 1, Overlap: .75'])

```

```
% Uncomment the next line for a b/w plot
%colormap(gray)

caxis([-12 12])
colorbar
plot(-cglon,cglat,'ko')
plot(-tgtlon,tgtlat,'ro')

% Plot cg box
plot([-84.27 -84.27 -84.11 -84.11 -84.27],...
      [25.61 25.71 25.71 25.61 25.61],'k--')
zoom on

if nargout > 0
    cout = c;
end
```

```

% COMPOSIT
%
% This script file will create a composite graph of many
% separate pings. For now, it will only work for SD mode
% pings.

% Location of the pings to combine
filepath = {'e:\schalm\LWAD 99-1 Data\Tape 17\sd\'};

%%% Default values (Modify if desired) %%%
interval = 1;
overlap = .75;
spacing = interval - interval*overlap;
%%%%%%%%%%%%%%%%%%%%%%%%%%%%%%%%%%%%%%%%%%%%%%%%%%%%%%%%%%%%%%%%%%%%%%%%

% Load the area stats file
area_stats_fname = ['e:\schalm\lwad 99-1\area_stats\'...
    'sd_stats' num2str(interval) '.mat'];

load(area_stats_fname)

if overlap == 0
    area_stats = stats_0;
elseif overlap == .25
    area_stats = stats_25;
elseif overlap == .5
    area_stats = stats_5;
elseif overlap == .75
    area_stats = stats_75;
end

% Get a directory of the pings to combine
D = dir(char(filepath));
[fname{1:length(D)}] = deal(D.name);

% get rid of '.' and '..' filenames
fname = fname(3:length(fname));

% Select the Lat/Lon you want to look at
% and the grid resolution
lon = -84.45:.01:-83.9;
lat = 25.45:.01:25.9;

composit_graph = zeros(length(lon),length(lat));
ref_matrix = zeros(length(lon),length(lat));

% Fill in the values of composit_graph one ping at a time

```

```

for m = 1:1:1
%for m = 1:1:length(fname)
    load([char(filepath) char(fname(m))], '-mat')
    disp(['Current file is ' char(filepath) char(fname(m))])
    [cglat,cglon,tgtlat,tgtlon] = lwad_posit...
        ([char(filepath) char(fname(m))]);
    [course,speed,ctrTbrng,botdepth,deangle] = ...
        lwad_prm([char(filepath) char(fname(m))]);
    cglon = -cglon;

for lon_index = 1:1:length(lon)
    for lat_index = 1:1:length(lat)
        % check to see if lat/lon is in range of the cg
        dx = 60*cos(cglat*pi/180)*(lon(lon_index)-cglon);
        dy = 60*(lat(lat_index) - cglat);
        range = sqrt(dx^2 + dy^2);

        if range > 9.9
            % do nothing because this is out of range
            % of the cg
        else
            brng = atan2(dy,dx);

            % Convert bearings to true (north up) bearings
            if brng < 0
                brng1 = -1*(brng*180/pi-90);
            else
                brng1 = 90-brng*180/pi;
            end

            if brng1 < 0
                brng1 = brng1+360;
            end
            brng1;
            beam_num = ceil(brng1/5);

            % Skip over data with 0 values --> cause errors
            % in statistics
            if sum(bmf(:,beam_num) == 0) > 0
                %do nothing

                % Skip over beams that are +/- 45 degrees
                % of the stern
            elseif course > 075 & course < 105 & ...
                beam_num > 45 & beam_num < 63
                % do nothing
            elseif course > 165 & course < 195 & ...

```

```

        (beam_num < 9 | beam_num > 63)
    % do nothing
else
    N = round(interval*samplerate);
    log_data = 20*log10(abs(bmf(:,beam_num)));
    mean_data = mmean(log_data,N,overlap);
    slope_data = (gradient(mean_data));
    diff_data = (slope_data - area_stats...
        (1,:))/spacing;
    sound_speed = .81; %nm/s
    data_time = range*2/sound_speed;
    index = round((data_time-.25)/.25);
    if index < 1
        index = 1;
    end
    diff_point = diff_data(index);
    composit_graph(lon_index,lat_index) = ...
        composit_graph(lon_index,lat_index)+...
        diff_point;
    ref_matrix(lon_index,lat_index) = ...
        ref_matrix(lon_index,lat_index) + 1;
end
end
end
end
end

% Divide the lat/lon matrix values by the number of
% entries at each point
composit_graph = composit_graph./ref_matrix;

% Plot the composite graph
figure
contourf(lon,lat,composit_graph'), hold on

% Uncomment the next line for a b/w plot
%colormap(gray)
caxis([-8 8]),
grid on,colorbar

xlabel('Longitude (W)'), ylabel('Latitude (N)')
title(['Composite Plot'])

% Plot cg box
plot([-84.27 -84.27 -84.11 -84.11 -84.27],...
    [25.61 25.71 25.71 25.61 25.61],'k--')
zoom on

```

```
%LWAD_FILE
%
% Use this script to open and load an LWAD 99-1 file

load data_drive
[filename,pathname] = uigetfile([data_drive]);
fname = [pathname filename];
data_drive = pathname;
save 'e:\schalm\lwad 99-1\data_drive.mat' data_drive

% Load the data file
load(fname, '-mat')
```

THIS PAGE INTENTIONALLY LEFT BLANK

LIST OF REFERENCES

1. Hopkins, C.K., "Shallow Water Issues for Meteorology and Oceanography (SWIM) Report," prepared for SPAWAR, San Diego, CA, 1999.
2. Johnson, J.L., "Forward ... From the Sea. The Navy Operational Concept," CNO, Washington, DC, 1997.
3. Urick, J., *Principles of Underwater Sound, 3rd ed.*, 237-287, McGraw Hill, New York, 1983.
4. Mackenzie, K.V., "Bottom Reverberation for 530 and 1030 cps Sound in Deep Water," *J. Acoust. Soc. Am.*, 33, 1498-1504, 1961.
5. Scanlon, G.L., R.H. Bourke and J.H. Wilson, "Estimation of Bottom Scattering Strength from Measured and Modeled Mid-Frequency Sonar Reverberation Levels," *IEEE J. of Oceanic Engineering*, 21(4), 440-451, 1996.
6. Medwin, H., and C.S. Clay, *Fundamentals of Acoustical Oceanography*, 1, Academic Press, Boston, 1998.

7. Osler, J., and C. Holland, "High Resolution Geo-Acoustic Models for the Surficial Sediments in the Capraia Basin, Northern Tyrrhenian Sea," Large Scale Acoustics and Oceanography Group, SACLANT Undersea Research Centre, Le Spezia, Italy, 1997.
8. Westwood, E.K., and P.J. Vidmar, "Eigenray Finding and Time Series Simulation in a Layered-Bottom Ocean," *J. Acoust. Soc. Am.*, 81, 912-924, 1987.
9. Erskine, F.T., J.F. McEachern and S.M. Tilden, "LWAD 99-1 Experiment Test Plan," Office of Naval Research, Washington, DC, 1999.
10. Fabre, J.P., and J.H. Wilson, "LWAD 99-1 Inversion Technique Experiment Trip Report," in LWAD 99-1 Quicklook Briefing Proceedings, Neptune Sciences Inc., encl(12), 1999.
11. Holmes, C.W., "Accretion of the South Florida Platform, Late Quaternary Development," *Bull., Am. Assoc. Pet. Geolog.*, 69, 149-160, 1985.

12. Gomes, B.R., J.K. Fulford and R. Nero, "Environmental Characterization for the Littoral Warfare Advanced Development Experiment (LWAD 99-1)," Naval Research Laboratory, NRL/MR/7184-99-8218, 1998.
13. Fulford, J.K., Personal Communication, Naval Research Laboratory, Stennis Space Center, MS, 25 May 1999.
14. Hamilton, E.L., and R.T. Bachman, "Sound Velocity and Related Properties of Marine Sediments," *J. Acoust. Soc. Amer.*, 72, 1891-1904, 1982.
15. Gomes, B.R., and R.A. Fisher, "Quicklook: Environmental Measurements During LWAD 99-1," in LWAD 99-1 Quicklook Briefing Proceedings, NRL Stennis, encl(6), 1999.
16. Kunz, E.L., "Bottom Backscattering Measured off the Southwest Coast of Florida During the Littoral Warfare Advanced Development 99-1 Experiment," Naval Research Laboratory, NRL/MR/7140-99-8389, 1999.

17. Neumann, P., and G. Muncill, "Bottom Scattering Inversion, PMW-185 Inversion Technique R&D Kick-Off Meeting," METOC Technology Division, Planning Systems Inc., McLean, VA, 11 August 1999.
18. Solinsky, J.C., Personal Communication, Neptune Sciences, Inc., San Diego, CA, May 1999.
19. Solinsky, J.C., "Clutter Rejection Approaches for Active Sonar Using Coherent, Non-Gaussian Statistics," *U.S. Navy J. of Underwater Acoustics*, 47(1), 98-118, 1997.
20. Solinsky, J.C., J.H. Howard and M.H. Miller, J.J. Feeney, "Classification of Acoustic Transients by Expert and Naïve Listeners," *U.S. Navy J. of Underwater Acoustics*, 45(2), 557-571, 1995.
21. Solinsky, J.C., "Trispectrum Utilization in Higher Order Statistical Applications," presented at the International Signal Processing Workshop on Higher Order Statistics Statistics, Chamrousse, France, 10-12 July 1991.

INITIAL DISTRIBUTION LIST

	No. Copies
1. Defense Technical Information Center.....	2
8725 John J. Kingman Road, STE 0944	
Ft. Belvoir, VA 22060-6218	
2. Dudley Knox Library.....	2
Naval Postgraduate School	
411 Dyer Rd.	
Monterey, CA 93943-5101	
3. Chairman, Code OC.....	2
Department of Oceanography	
Naval Postgraduate School	
833 Dyer Rd. Room 328	
Monterey, CA 93943-5122	
4. Dr. Robert H. Bourke, Code OC/BF.....	2
Department of Oceanography	
Naval Postgraduate School	
833 Dyer Rd. Room 342B	
Monterey, CA 93943-5122	
5. Commanding Officer.....	1
Naval Research Laboratory	
Code 5100/5123	
Washington, DC 23037-5000	
Attn: Dr. Fred Erskine	
6. Dr. James H. Wilson.....	4
Neptune Sciences, Inc.	
3834 Vista Azul	
San Clemente, CA 92674	
7. Mr. Ed Jensen.....	1
Naval Undersea Warfare Center Division	
1176 Howell St.	
Newport, RI 02841-1708	
8. Program Executive Office (PMS-411).....	1
Surface Ship ASW Systems	
Washington, DC 20362-5104	
Attn: Capt. W.D. Morris	
Attn: Dr. Wayne Beers	

- 9. CAPT Charles Hopkins/Mr. Kim Koehler..... 1
 Naval Space and Warfare Command
 PMW-185
 153560 Hull St.
 San Diego, CA 92152-5002
 Attn: LCDR Daphne Kapolka (PMW-181)

- 10. Mr. Ken Dial/Ms. Nancy Harned..... 2
 Office of Naval Research
 Code 321
 800 North Quincy Street
 Arlington, VA 22217-5660

- 11. Dr. Adam Cohan (Code-4454)..... 1
 Naval Aviation Warfare Center/Aircraft Division
 22347 Cedar Point Road
 Bldg. 2185, Rm. 1160
 Patuxent River, MD 20670

- 12. ADM B. Smith..... 1
 Naval War College
 Naval Warfare Development Command
 686 Cushing Road
 Newport, RI 02841-1207
 Attn: D. Summer (Code-253)

- 13. LT David A. Schalm..... 1
 5918 Hadrians Crescent
 Anaheim, CA 92807