

AFRL-ML-TY-TR-1998-4513

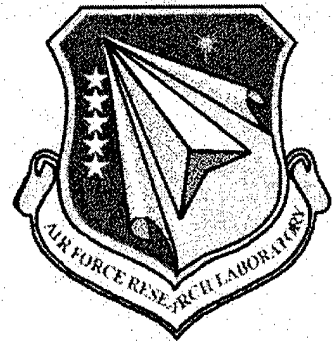

HAZARDOUS WASTE MINIMIZATION OF PAINT OVERSPRAY VIA MEDIALESS DYNAMIC PARTICLE FILTRATION

**STEVE R. WRIGHT
JEFFREY H. BOND**

**INNOVATECH, INC.
4608-D INDUSTRY LANE
DURHAM NC 27713-5414**

25 MARCH 1998

FINAL REPORT 25 APR 97 - 25 JAN 98

Approved for Public Release; Distribution Unlimited

20000104 044

**AIR FORCE RESEARCH LABORATORY
MATERIALS & MANUFACTURING DIRECTORATE
AIRBASE & ENVIRONMENTAL TECHNOLOGY DIVISION
TYNDALL AFB FL 32403-5323**

DTIC QUALITY INSPECTED 2

NOTICES

USING GOVERNMENT DRAWINGS, SPECIFICATIONS, OR OTHER DATA INCLUDED IN THIS DOCUMENT FOR ANY PURPOSE OTHER THAN GOVERNMENT PROCUREMENT DOES NOT IN ANY WAY OBLIGATE THE US GOVERNMENT. THE FACT THAT THE GOVERNMENT FORMULATED OR SUPPLIED THE DRAWINGS, SPECIFICATIONS, OR OTHER DATA DOES NOT LICENSE THE HOLDER OR ANY OTHER PERSON OR CORPORATION; OR CONVEY ANY RIGHTS OR PERMISSION TO MANUFACTURE, USE, OR SELL ANY PATENTED INVENTION THAT MAY RELATE TO THEM.

THIS REPORT IS RELEASABLE TO THE NATIONAL TECHNICAL INFORMATION SERVICE (NTIS). AT NTIS, IT WILL BE AVAIABLE TO THE GENERAL PUBLIC, INCLUDING FOREIGN NATIONS.

THIS TECHNICAL REPORT HAS BEEN REVIEWED AND IS APPROVED FOR PUBLICATION.



JOSEPH D. WANDER, PhD
Program Manager



CHRISTINE WAGENER-HULME, Lt Col, USAF, BSC
Chief, Environmental Technology Development Branch



RANDY L. GROSS, Lt Col, USAF, BSC
Chief, Airbase & Environmental Technology Division

REPORT DOCUMENTATION PAGE

Form Approved
OMB No. 0704-0188

Public reporting burden for this collection of information is estimated to average 1 hour per response, including the time for reviewing instructions, searching existing data sources, gathering and maintaining the data needed, and completing and reviewing the collection of information. Send comments regarding this burden estimate or any other aspect of this collection of information, including suggestions for reducing this burden, to Washington Headquarters Services, Directorate for Information Operations and Reports, 1215 Jefferson Davis Highway, Suite 1204, Arlington, VA 22202-4302, and to the Office of Management and Budget, Paperwork Reduction Project (0704-0188), Washington, DC 20503.

1. AGENCY USE ONLY (Leave blank)	2. REPORT DATE 25 Mar 98	3. REPORT TYPE AND DATES COVERED FINAL 25 Apr 97 - 25 Jan 98
----------------------------------	-----------------------------	---

4. TITLE AND SUBTITLE Hazardous Waste Minimization of Paint Overspray Via Medialess Dynamic Particle Filtration	5. FUNDING NUMBERS F41624-97-C-0018 65502F 3005EM7E
--	--

6. AUTHOR(S) Steven R. Wright and Jeffrey H. Bond	8. PERFORMING ORGANIZATION REPORT NUMBER 98-AF-Phase I
--	---

7. PERFORMING ORGANIZATION NAME(S) AND ADDRESS(ES) InnovaTech, Inc. 4608-D Industry Lane Durham, NC 27713-5414	10. SPONSORING/MONITORING AGENCY REPORT NUMBER AFRL-ML-TY-TR-1998-4513
---	---

9. SPONSORING/MONITORING AGENCY NAME(S) AND ADDRESS(ES) AFRL/MLQE 139 Barnes Drive, Ste 2 Tyndall AFB FL 32403-5323	11. SUPPLEMENTARY NOTES Technical Monitor: Dr. Joe Wander; AFRL/MLQE; (850) 283-6240; DSN 523-6240
--	--

12a. DISTRIBUTION AVAILABILITY STATEMENT Approved for Public Release; Distribution Unlimited	12b. DISTRIBUTION CODE A
---	-----------------------------

13. ABSTRACT (Maximum 200 words)
A novel medialess dynamic particle filtration technique, extending patented Boundry Layer Momentum Transfer (BLMT) technology, removes sticky aerosols without contaminating mechanical collection media. In this filter, incoming air passes through boundry layers generated on parallell stacks of rotating disks, excluding particles larger than a critical size, and allowing their agglomeration and collection. Because no paint solids accumulate on the rotating surfaces, flow, back pressure and filtration efficiency remain constant. It thus met the two project goals of decreasing HazWaste generation and removing paint as well as a conventional arrestor.
An 800-ACFM prototype BLMT, spinning 180 eight-inch-diameter disks at 4,000 RPM, excluded > 98% (by mass) of a directly sprayed aerospace paint without fouling. In combination with a downstream volatile organic compound (VOC) control unit, this BLMT device will abate hazardous paint overspray emissions at or below Clean Air Act standards. Paint solids may be recovered for recycling. Unlimited scale-up is feasible using multiple modular devices, which can also tailor air movement. Projected annual operating and initial acquisition costs for a 25,000-ACFM BLMT system are - 35% less than for an equivalent, conventional three-stage filter system.

14. SUBJECT TERMS Paint Overspray, Aerosol, Aerospace NESHAP, Environmental, PM-2.5, Filtration, Chromates, Particle Arrestor, Inertial Seperator, Boundry Layer, Filter	15. NUMBER OF PAGES 62
	16. PRICE CODE

17. SECURITY CLASSIFICATION OF REPORT UNCLASSIFIED	18. SECURITY CLASSIFICATION OF THIS PAGE UNCLASSIFIED	19. SECURITY CLASSIFICATION OF ABSTRACT UNCLASSIFIED	20. LIMITATION OF ABSTRACT UL
---	--	---	----------------------------------

PREFACE

This is the final report for a phase I feasibility study, "Hazardous Waste Minimization of Paint Overspray Via Medialess Dynamic Particle Filtration." It documents significant results and major accomplishments for work performed between 25 April 1997 and 25 January 1998. This study was funded, in part, by DoD, through the Air force, under the Small Business Innovation Research program, Contract No. F41624-97-C-0018.

The authors acknowledge the valuable contributions of and technical consultation provided by our Contracting Officer Technical Representative (COTR), Dr. Joseph Wander, at AFRL/MLQE, Tyndall AFB, FL. The following InnovaTech executive personnel contributed to the production and review of the report: Mr. H. Steven Crouch (President/CEO), Dr. Steve R. Wright (Vice President/R&D), and Mr. Jeff Bond (Manager/New Product Development). Mr. Crouch also administered the Air Force SBIR Phase I contract.

The research was conducted in InnovaTech's facilities in Durham, N.C. Mr. Tony Knight, Mr. Joe Voelker and Mr. Jeff Storm conducted in-house filter testing. Mr. Knight (Sr. Mechanical Engineer) provided all of the CAD schematics and drawings for the report and interfaced with local vendors for prototype component modifications and fabrication. Mr. Voelker (Engineering Test Manager) performed both mass balance and fractional efficiency filter testing of the prototypes, with assistance from Mr. Storm (Project Engineering Manager). All three were responsible for component assembly and construction of the individual prototypes. Mr. Storm was instrumental in fine tuning the balancing of the disk packs for shakedown rig tests.

This research and development support does not constitute an endorsement by DoD of the views or conclusions expressed in this report.

EXECUTIVE SUMMARY

A. OBJECTIVE

The objective of this phase I Small Business Innovation Research (SBIR) project was to test the feasibility of using a developmental technology, Boundary-Layer Momentum Transfer (BLMT), to remove overspray particles from air used to ventilate spray-painting processes.

B. BACKGROUND

Disposal of contaminated filter medium is a significant cost element of spray painting operations. The National Emission Standard for Hazardous Air Pollutants [NESHAP] applicable to aerospace coating processes excludes the use of waterfall particle controls, specifying stationary filters or alternative devices affording equivalent or better control performance at each of three particle-size ranges defined in Method 319. Toxic exposure to painters when recirculating ventilation is employed is affected by the amount of respirable overspray particles penetrating the filter system.

Boundary-Layer Momentum Transfer (BLMT) is achieved by delivery of a particle-containing fluid through an evenly spaced stack of annular plates while the stack of plates is spun in plane. Centripetal acceleration is imparted to particles approaching the spinning annuli, and particles experiencing centrifugal force greater than the pressure gradient are actively excluded and eventually collected behind the BLMT. BLMT is presently being tested for applications involving dry particulate matter [containment of radioactive fines (DOE) and exclusion of abrasive dusts (Army)]. The same principle has also been proposed as a method for classifying the size of particles as small as 10 μm in water.

C. SCOPE

This report describes the results and conclusions of a phase I Small Business Innovation Research (SBIR) project performed in the laboratory of InnovaTech, Inc., under contract F41624-97-C-0018, from 25 April 1997 to 25 January 1998.

D. METHODOLOGY

Overspray particles were collected on specimen pedestals and analyzed by scanning electron microscopy (SEM) to determine size and by energy-dispersive X-ray spectroscopy (EDX) to estimate the amount of chromium present. Pressure drop across the BLMT was measured by difference. Paint particles were generated by a standard HVLP spray gun delivering a polyurethane topcoat (MIL-C-83286B) or a chromated epoxy primer (MIL-P-23377F), all supplied by the Air Force. Spraying was performed in a temporary, 4-foot-by-4-foot-by-8-foot plywood enclosure, the back wall of which was cut out as needed to accommodate installation of BLMT rotors.

E. TEST DESCRIPTION

Separate sets of overspray samples were collected for primer and topcoat to verify representative distribution of particle sizes, and to determine the distribution of chromium in primer particles as a function of size [to support selection of a size cutoff to design for]. An existing 100-cfm BLMT rotor in a housing that allowed radial approach to the channels was installed and challenged with paint spray during an uninstrumented, qualitative, initial test. After 30 of the 100 annular plates were coated with Teflon™, the rotor was again challenged with paint spray. SEM measurements were made of annular surfaces after each exposure.

A pilot BLMT rotor was fabricated from 180 uncoated annular plates, 8 inches outer and 7 inches inner diameter by 0.762 mm, that were bent 30° out-of-plane from 7.5 inches to the outer edge. The plates were uniformly spaced at 1 mm. The rotor was mounted in a scroll housing, which created cyclonic circulation that enforced tangential approach to the BLMT and actively collected the excluded particles on its inner surface of the housing. While 800 cfm of air was drawn through the BLMT, the HVLP gun sprayed 705 g of paint into the enclosure [35 minutes delivery time], which had been lined with tared contact paper. Increases of weight of the lining paper and of a 95-percent ASHRAE filter downstream of the BLMT, plus composition data reported in the supplier's material safety data sheet [MSDS] were used to calculate capture efficiency.

F. RESULTS

In the initial pedestal studies, the distribution of primer particles was in acceptable agreement with expectation, and chromium concentrations were generally uniform down to about 6 μm, the apparent resolution limit of the EDX for these samples. The topcoat particles flowed together, so these data were inconclusive. In the qualitative test of the 100-cfm BLMT, excluded particles were seen to persist around the entrance to the BLMT, which inspired reconfiguration of the housing for the 800-cfm model. SEM analyses determined that paint particles had settled on the faces of the annular plates, and that (as predicted) deposition was decreased by application of a Teflon™ coating and by increasing the rate of rotation of the BLMT. The housing surface of the 800-cfm model captured enough paint that it collected as a flowing liquid. Accumulation was also observed in the exhaust housing from the BLMT and on a rotating seal inside the BLMT. Only a thin film collected on the exposed edge of the rotor. Of 256 g (calculated) of paint solids delivered into the enclosure, 220 g entered the BLMT and 7.5 g collected on the 95-percent ASHRAE filter, giving a capture efficiency of 96.6 percent. This was recalculated as 98 percent after the 95-percent filter eventually decreased in mass by 3 g. Pressure drop in projected operating ranges is several inches w.g. Cost estimates in Appendix A suggest that cost avoidance for waste disposal will exceed installation and operating costs for the BLMT.

G. CONCLUSIONS

The capture data indicate that the BLMT is an effective device for removal of >95 percent of paint solids from a small paint booth. The paint delivery rate was high [2.5 g/ft²-min at 100 lfm], the distance from the gun to the BLMT was only a few feet, and the design tested was not optimized. Also, evaporation causes the dimensions and composition of the droplets to change in flight, and leakage around the rotating seal cannot be estimated. Therefore, an upper bound cannot confidently be estimated for removal by the BLMT [although it appears to be at least as effective as a cyclone separator], but significant potential exists for optimization of the design. Controlling accumulation of paint on interior surfaces may prove to be a challenge for this technology. A significant bonus is that judicious scaling and placement of a set of BLMTs across the exhaust wall would allow adjustment of airflow patterns in large painting facilities.

No data exist to address the size cutoff for either paint tested in this BLMT; however, data measured earlier for vegetable-oil mists imply that 80-percent removal at 1 μm can be attained at a ΔP of approximately 12 inches w.g. If a device that meets the standards of Method 319 proves to cause an intolerably large ΔP, the BLMT may still be useful as a lower-waste-generating replacement for the coarse filters preceding the final stage.

H. RECOMMENDATIONS

The BLMT concept merits further attention. Several issues critical for eventual commercialization will be addressed during phase II R&D activities:

1. Particle size discrimination. This will determine the role [prefilter or complete particle-control system] of the BLMT.
2. Removal of collected paint solids. A disposable liner for the BLMT housing could collect much greater loadings of paint than a stationary filter, which would realize a reduction in solid waste. However, material or energy recovery may become practical for so concentrated a treatment residue.
3. Accumulation of paint in the BLMT. The same liner would protect most of the static elements of the BLMT. If the fluffiness of the dried residue remains constant, a combination of close tolerances and centrifugal acceleration may be sufficient to limit the accumulation acceptably.
4. Device scale-up. An 800-cfm flow can service only two 24-inch-by-24-inch filters at the minimum flow rate specified in 29 CFR 1910. Issues will be material stability of the larger rotors and ΔP.

Life-cycle cost. Data from pilot testing will be used to produce more-reliable estimates of the acquisition, operation and maintenance, and disposal costs to replace static filters with BLMT(s).

TABLE OF CONTENTS

	Page
1. INTRODUCTION	1
2. BACKGROUND AND TECHNICAL APPROACH	4
2.1 Discussion.....	4
2.2 Theory Description	8
2.3 Regulatory Requirements	11
3. PHASE I TECHNICAL OBJECTIVES	13
4. EXPERIMENTAL RESULTS	14
4.1 Task 1	14
4.2 Task 2	21
4.3 Task 3	24
4.4 Task 4	26
5. RECOMMENDATIONS FOR PHASE II.....	28
6. CONCLUSIONS.....	31
7. POTENTIAL POST APPLICATIONS	31
REFERENCES	32
APPENDIX A--Economic Analysis: BLMT vs. Conventional Media (3-Stage) Overspray Systems.....	35
APPENDIX B--Data to Support Table 16: Pressure Recovery Using a BLMT Exit Scroll	47

LIST OF FIGURES

<u>Figure</u>	<u>Page</u>
FIGURE 1. Typical Paint Arrestor Overspray Efficiency Curve, Contrasting Paint Overspray Size Range with Respirable Aerosol Size Range [6]	1
FIGURE 2. Fractional Filtration Efficiency Curves for Various Types of Filters as a Function of Aerodynamic Particle Diameter [6]	3
FIGURE 3. Force Balance on Different Sized Particles Attempting to Enter the BLMT Filter at the Boundary Layers	5
FIGURE 4. Cut-Away Illustration of the BLMT Exclusion Filter	6
FIGURE 5. Schematic of an 800-ACFM BLMT Paint Overspray Arrestor Prototype	8
FIGURE 6. BLMT Correlation Coefficient vs. Disk Spin Rate	11
FIGURE 7. Fractional Filtration Efficiency as a Function of Aerodynamic Particle Diameter for a Typical Two-Stage Paint Overspray Arrestor [6]	12
FIGURE 8. Schematic of the BLMT Paint Overspray Experimental Setup	15
FIGURE 9. SEM Photomicrograph of Several Primer Overspray Particles at 110X Magnification	16
FIGURE 10. Typical Cumulative Size Distributions of Strontium Chromate Particles Suspended in Aerospace Paints, Showing Count and Volume Distributions [21, 22]	17
FIGURE 11. BLMT Particle Size Distributions for ISO-Ultrafine Dust as a Function of Aerodynamic Particle Size for Various Disk Spin Rates	19
FIGURE 12. BLMT Particle Size Distributions for Vegetable Oil as a Function of Aerodynamic Particle Size for Various Disk Spin Rates	19
FIGURE 13. 800-ACFM BLMT Disk Pack With Exhaust Port	21
FIGURE 14. Pressure Drop vs. Flow Rate for the 800-ACFM BLMT Filter at Incremental Disk Spin Rates	23
FIGURE 15. Fractional Filtration Efficiency vs. Particle Size for Various Disk Spin Rates at Constant Volumetric Flow	24
FIGURE 16. Pressure Recovery Using a BLMT Exit Scroll	26

LIST OF FIGURES (CONTINUED)

<u>Figure</u>	<u>Page</u>
FIGURE 17. Interleaving Seal Design Modification Enhancement for Phase II Incorporation.....	30
FIGURE 18. Clearance Seal Design Modification Enhancement for Phase II Incorporation.....	30

LIST OF TABLES

<u>Table</u>	<u>Page</u>
TABLE 1. Theoretical vs. Empirical Particle Cut-Off Sizes for Various Spin Rates for a Specific BLMT Filter/Housing Combination.....	10
TABLE 2. Minimum Filtration Efficiencies as a Function of Aerodynamic Particle Size for Compliance With the 1998 Aerospace NESHAP (Existing Facilities) [6].....	11
TABLE 3. Minimum Filtration Efficiencies as a Function of Aerodynamic Particle Size for Compliance With the 1998 Aerospace NESHAP (New Facilities) [6].....	12
TABLE 4. Summary of Phase I Tasks.....	14
TABLE 5. Test Parameters Used in the 100-ACFM BLMT Overspray Filter.....	18
TABLE 6. Annual Cost Comparison Summary for Conventional Three-Stage and BLMT Paint Overspray Filters.....	27
TABLE 7. Projected First-Year Total Cost/ACFM Comparison Summary for Conventional Three-Stage and BLMT Paint Overspray Filters.....	28
TABLE 8. Design Parameters Required for a 2,500-ACFM BLMT Overspray Filter.....	29

1. INTRODUCTION

Military painting operations generate very fine, sticky aerosol particles containing chromates and other toxic metals, or isocyanates, all considered hazardous air pollutants (HAPs). Conventional paint spray booths/rooms must contain these HAPs under EPA emission regulations. At present, conventional filtration systems for military paint overspray tend to be expensive to install, service and maintain. Operation and maintenance (O&M) costs for these treatment systems have become a major environmental clean-up budget component [2]. These filtration systems must comply with EPA PM₁₀ standards under the 1990 Clean Air Act Amendments (CAAA). According to recently released government documents, more-restrictive PM_{2.5} regulations may soon augment PM₁₀ as the standard emission compliance requirement for fine particles. Military paint overspray conditions are regulated by the EPA's Aerospace NESHAP. Even high-efficiency (*i.e.*, 99-percent arrestance *by weight*) paint overspray arrestors allow penetration by respirable-sized aerosol particles [4, 5, 20, 21]. This is important when those penetrating particles contain hazardous components, such as chromates found in aerospace paint formulations.

Figure 1 [6] exhibits a typical paint arrestor efficiency curve with typical paint overspray particle sizes, normal respirable size ranges, and the typical mass median diameter (MMD) size ranges. Arrestor efficiency is extremely low for particles below 1 μm in diameter, climbs substantially between for particles ranging between 1 and 6 μm , and generally becomes absolute for particles exceeding 10 μm . Note that a substantial fraction of particles in the 2-to-3- μm range, which represents the low range of chromate particle sizes in paint typically used in US military applications, can pass through paint arrestor media.

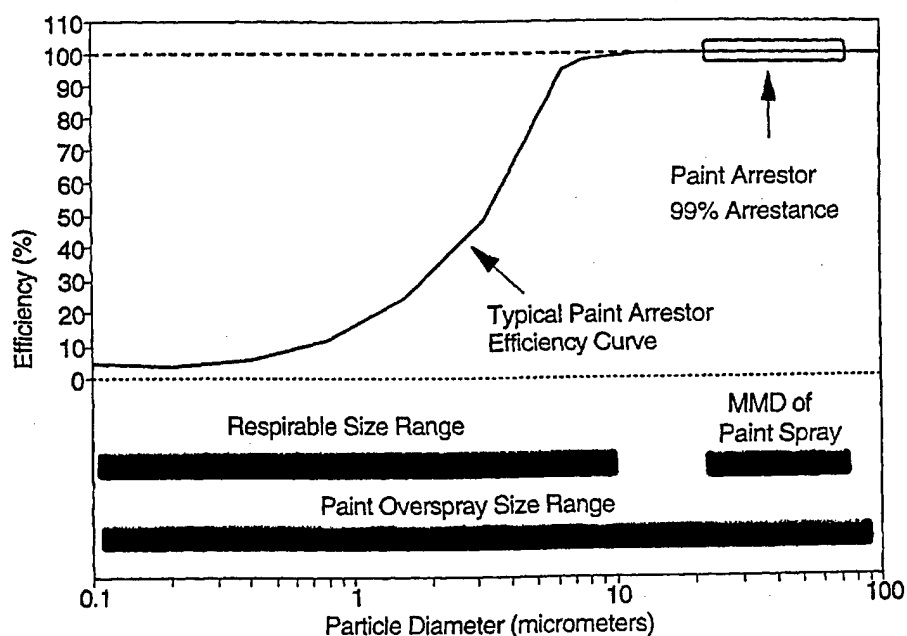

FIGURE 1. Typical Paint Arrestor Overspray Efficiency Curve, Contrasting Paint Overspray Size Range with Respirable Aerosol Size Range [6]

To reduce hazardous waste production from current levels in military painting operations, a filtration methodology must either mitigate paint sludge capture/handling from water curtain overspray filters or significantly reduce contaminated filtration media disposed at hazardous waste landfills or by incineration. One potential technique that would mitigate environmental consequences of these USAF operations is a newly introduced, medialess, dynamic inertial filter (InnovaTech's BLMT technology) that operates by rejection of particulate matter passing through defined boundary layers; air is allowed to pass through the device while particles are expelled. Overspray particles can therefore be captured for disposal or recycling without contaminating filtration media, thus significantly reducing the physical volume of hazardous waste that must be disposed. Alternatively, dry (or semi-dry) capture of the paint overspray aerosol solids would drastically reduce the sludge handling/separation problems of water curtain overspray filters. For a complete system, the BLMT methodology must also be combined with effective VOC capture downstream (*e.g.*, activated carbon, etc.); efficient capture of particles upstream with the BLMT filter may extend the service lifetime of the VOC control devices.

New environmental emission regulations will place an additional burden on the traditional barrier-type filter systems that utilize media to capture and retain overspray particles. Figure 2 [3, 6] shows a wide range of particle filtration efficiency curves for various types of conventional media-based filters as a function of particle size. The relative cost of these filters increases dramatically as their overall efficiencies rise, particularly in the smaller size ranges (less than 10 μm). Whereas single-stage particle arrestors can cost on the order of pennies per square foot, high-efficiency particulate air (HEPA) filters can cost many tens of dollars per square foot. Thus, HEPA filter performance (as exemplified in Figure 2) can meet any of the foreseeable particle emission criteria for paint overspray particle arrestors [7, 8], but unacceptably high costs preclude their widespread use. Even 95-percent American Society of Heating, Refrigeration, and Air Conditioning Engineers (ASHRAE) filters are perceived too costly, particularly when they must be frequently replaced. With relatively high particle loadings (specifically for particles below 10 μm) common in the generation of paint overspray, these high-efficiency filters foul very quickly, requiring frequent replacement. Paint overspray arrestors differ significantly from typical solid particle filters. Quasi-liquid, sticky paint particles that accumulate in overspray arrestors generally reduce collection efficiency over time (since the collected particles can coalesce and block fine penetration channels through the media). This is in contrast to solid particle filters, which typically build up a porous surface cake that actually enhances collection efficiency over time [9-11].

Unfortunately, media-based barrier filters that are used to collect paint overspray particles will quickly generate a large pressure drop due to this sticky particle accumulation on the media face. Thus, frequent periodic maintenance and replacement of the filter is required due to progressive fouling, resulting in a varying operational pressure profile (*i.e.*, a sawtooth pressure drop pattern). Although water curtain paint overspray filters remove significant amounts of hazardous particulate matter from the air, they also generate a hazardous sludge entrained in large quantities of process water, which must then be separated/removed, thus shifting the pollution problem from air to water.

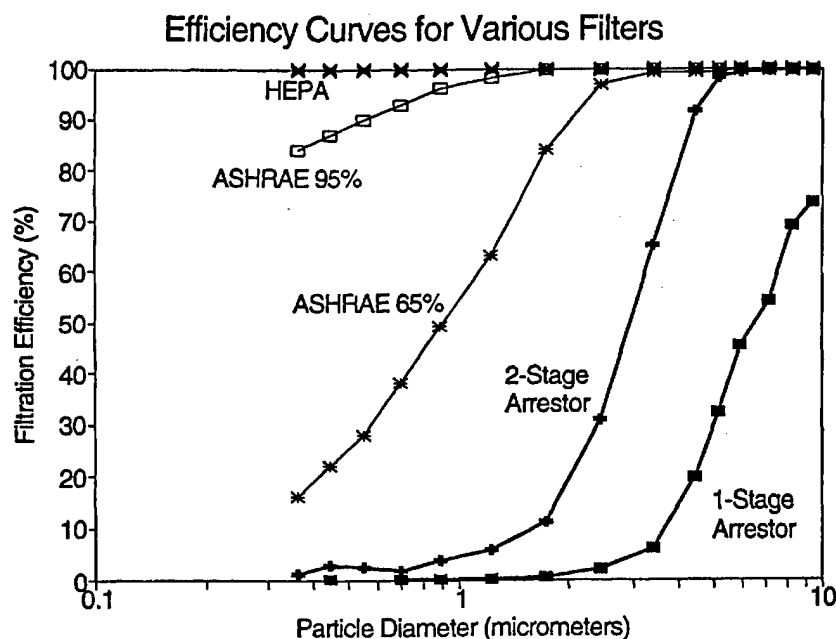

FIGURE 2. Fractional Filtration Efficiency Curves for Various Types of Filters as a Function of Aerodynamic Particle Diameter [6]

InnovaTech, Inc., formerly Micro Composite Materials Corporation, has developed a new *dynamic* filtration technology that has many characteristics far superior to conventional filters. The mechanical filtration device actively "excludes" particles of a specified size and mass from entering the device, thus it is inherently self-cleaning and does *not* require replacement of the filter element. Moreover, periodic replacement and back-pulse cleaning, common in conventional media filters, would be eliminated entirely, greatly simplifying and further reducing operational costs, as well as enhancing worker safety. As previously mentioned, the disposal of contaminated filtration media would also be eliminated, significantly minimizing the volume of hazardous waste generated by the DoD operations traditionally requiring these types of filtration systems.

Additionally, previous application-specific studies for this new type of filter show that the pressure drop across the filter can be designed to be on the order of three percent (*i.e.*, 12 inches w.g.) or less. The pressure drop across the InnovaTech device would remain constant and not increase with time as it does with conventional porous barrier-type filters when they begin to foul or clog. Filter performance with the exclusion filter would therefore be a predictable constant.

Examples of other military processes generating contaminated airstreams that would also benefit from this filtration research include jet engine test cells (exhaust gases), abrasive depainting operations, incineration, fossil fuel-fired boiler operations, as well as numerous civilian industrial and power generation processes. Oil and/or cutting fluid mists could also be eliminated in machining operations. Although the methodology presented in this report addresses only aerosol particle collection, the device could be combined with other technologies to encompass VOC

elimination, as well. The results of redesign and testing of this novel particle extraction methodology will be presented as applied to the problem of **sticky liquid aerosol particles**. Several potential problem areas were addressed in this Phase I study which would be barriers to industry acceptance of this new type filter for liquid aerosol separation, or critical issues that would preclude its use without further investigation and resolution. These included

- Significant device scale-up to much larger inlet flow rates,
- Inlet vs. outlet particle size distribution for accurate filtration efficiency measurements,
- Redesign with the possible incorporation of an upstream mister to accommodate efficient wet sludge collection/removal and possible recycle,
- Potential sticky particle build-up if the aerosol is allowed to dry or adheres to the edges of the filtration disks or housing, and
- Accurate estimates of anticipated cost per ACFM of the device, including any design changes, for economic comparisons with conventional technologies.

In summary, successful resolution of the above issues in this investigation will provide the DoD with a novel aerosol particle exclusion filter having the following characteristics:

- A constant, predictable pressure drop across the filter,
- Constant, predictably high level of aerosol particle removal,
- Adjustable device operational parameters to vary separation efficiency and/or pressure drop,
- No need to dispose of contaminated filter media,
- Reduced sludge-handling complexity as compared to water curtain filtration systems,
- Enhanced worker operational safety (reduced exposure to hazardous wastes),
- Compliance with new EPA requirements for fine particle emissions,
- Decreased environmental consequences of Air Force operations,
- Capability to collect aerosol paint for recycling or reuse, and
- Applicability to other DoD and civilian operations (besides painting).

2. BACKGROUND AND TECHNICAL APPROACH

2.1 Discussion

Conventional filtration systems can be based on the concepts of inertial particle separation (such as cyclones) or particle entrapment (media-based barrier-type filters) from the gas flow, or a combination of the two. During cyclonic separation, dirty gas is forced to flow through a spiral pathway. The sharp spiral turns cause centripetal acceleration, forcing entrained particles in the gas to separate from the primary flow stream. Because much greater inertia is developed by larger particles than smaller ones, the larger particles are easier to separate from the gas stream, resulting in exit "cleaned" gas entraining primarily smaller particles. Cyclonic filters are typically capable of removing larger particles (greater than 20 μm) entrained in the incoming airstreams. Finally, barrier-type filters (*i.e.*, cartridge, bag, HEPA, etc.) are used to remove the finer particles (less than 20 μm).

The patented **Boundary Layer Momentum Transfer (BLMT)** exclusion filter developed by InnovaTech has been designed from the outset to achieve extremely fine particle de-entrainment capabilities at a low, constant pressure drop. The physics of the device can be expressed in a simple force balance equation as illustrated in Figure 3: the inward drag force on the particles is opposite that of the outward centrifugal force transferred to the particles through the boundary layers created by the spinning disks. At a critical particle diameter defined by the geometry and operational parameters of the device, the two forces are exactly balanced (*i.e.*, the particle "orbits" the device).

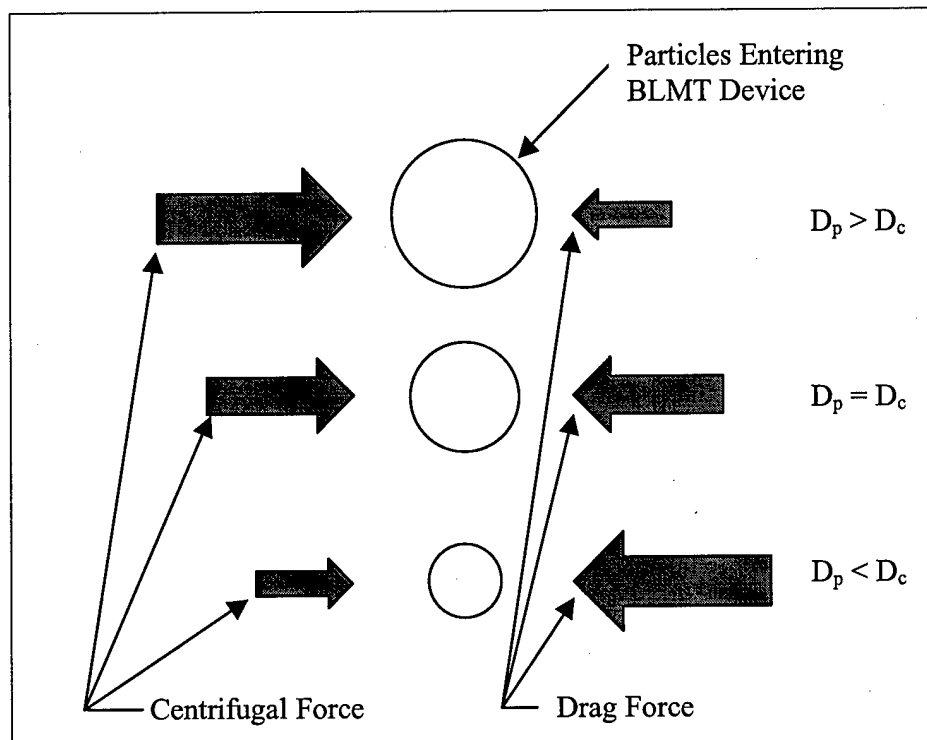

FIGURE 3. Force Balance on Different Sized Particles Attempting to Enter the BLMT Filter at the Boundary Layers
 (D_p = particle diameter; D_c = critical cut-off diameter)

The set of close-spaced spinning disks that constitute the filter establish a multiple series of boundary layers between each disk pair in the set. A schematic of a vertically-oriented BLMT filter is illustrated in Figure 4, identifying flow paths and critical components. The housing/inlet area, disk pack and air exit areas are shown as cross sectional views. The air flows into the housing, flows around the disk pack until it is drawn into the center of the disk pack, and exits through the central exhaust port connected to the plenum at the bottom of the housing. The geometric and operational parameters to which the filter has been designed establishes the particle cut-off size, above which particles are actively **excluded** from the filter. For example, at this critical cut-off size, the drag force on the particle due to the suction of a downstream blower or exhaust stack exactly balances the expulsion force due to the imparted centripetal acceleration on the particle entering the boundary layer between the disks. If the particle size is above this

critical diameter, the centrifugal expulsion force dominates the force balance equation (*i.e.*, the particle is ejected from the perimeter of the device). Conversely, if the particle size is below this critical diameter, the inward drag force on the particle is sufficient to overcome the centrifugal force, and the particle can therefore enter and pass through the device.

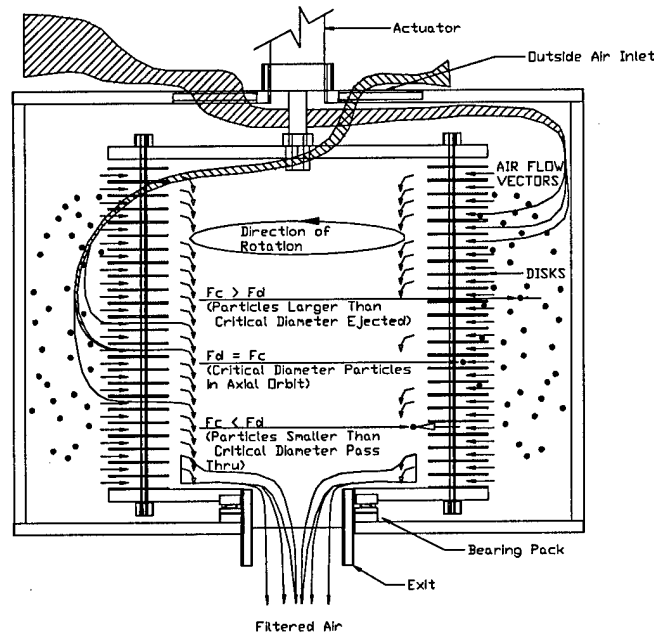

FIGURE 4. Cut-Away Illustration of the BLMT Exclusion Filter

The device can be visualized as a stack of evenly-spaced circular disks, each having large concentric holes. For ease of visualization, think of this as analogous to a stack of old 45-RPM records on a hollow turntable spindle. Assume that the disk widths and the spacing between each of the disks are a few millimeters or less. If one end of the core is capped and this hollow core stack of disks is rotated at several thousand revolutions per minute (RPM), the gas pressure will be reduced at the core due to the gas flow requirements of the downstream blower and particle-laden gas will be drawn to the perimeter of the rotating disks. The rotation of the disks establishes a boundary layer on each side of every disk in the stack. The pressure drop (from outer edge to inner edge) is caused by the frictional drag of the filtered gas traversing the boundary layers.

The operational and geometric parameters of the filter for this application show that only laminar boundary layers will be established on both sides of each of the rotating disks in the stack [12–16]. Since only laminar (creeping) flow will be encountered in the present design configuration, disk surface roughness (important in turbulent flow regimes) will not be a factor in determining flow characteristics through the device. Filter system parameters (such as disk size, spacing between disks, rotational speed, downstream pressure, ambient gas conditions, etc.) establish the pressure drop across the rotating exclusion filter (see Equation 2 in Section 2.2). Particle-laden process gas enters the disk stack from the perimeter and, after exclusion of particles larger than the size cut-off, only the filtered process gas exits the device through the uncapped end of the

disk stack. Angular momentum transfer from the rotating disks via the inter-disk boundary layers causes any particles above the critical diameter that are entrained in the incoming gas to be immediately expelled away from the device perimeter.

For low volumetric flow rates (*i.e.*, less than 1,000 ACFM), the rotational requirement for the device can easily be supplied by a small-horsepower (HP) electric motor. Power requirements are minimal due to relatively low boundary layer drag losses, since the rotating (non-aerodynamic) disks easily maintain constant velocity with little power drain once accelerated.

Subject to device parameters, particles that attempt to enter the airflow envelope of the device will be automatically ejected due to the momentum gained by the particles by centripetal acceleration imparted from the rotating disks by means of the boundary layers on the rotating disks. Gas molecules, which have orders of magnitude less mass than particles, can flow against the "stationary" boundary layers established by the rotating disks. There is an associated drop in pressure due to this aerodynamic drag loss. Particles, however, enveloped in one of the multiple series of parallel boundary layers in the rotating disk pack, accumulate enough momentum to be ejected from the outer perimeter of the filter.

An additional attribute of this filter, besides its inherent self-cleaning capability, is the relatively easy variability of the system parameters so that any size range of particles can be excluded from the inlet process gas stream. Complementary research projects at InnovaTech have demonstrated micron and even submicron separation capabilities with this unique device. The inter-disk spacing, the disk outside diameters or their rotational speed can be varied to tailor the separation efficiency of the filter.

The disk material can be made of a wide variety of corrosion- and abrasion-resistant materials to suit specific applications. The disks do not need to be very thick (*i.e.*, metal foils are often acceptable) to operate effectively. Material choice will, of course, depend upon the design conditions and desired operational life expectancy of the device. For this application, a polymer disk or coating (*e.g.*, TeflonTM) having a low affinity for paint particles would be the best candidate.

Figure 5 presents an illustration of InnovaTech's 800-ACFM BLMT Paint Overspray Arrestor arrangement. Note the filter housing resembles a fan scroll housing, but the airflow is reversed from that traditional arrangement. Airflow exits the BLMT disk pack as a tightly-wound vortex that "de-spins" in the pressure recovery exit scroll.

Unlike barrier filters where the particles are collected on the filter medium, the BLMT exclusion filter is innately self-cleaning and cannot foul, blind or clog. Because the particles are quickly expelled away from the perimeter of the rotating filter disks, the particles never really broach the filter perimeter. For this application, the BLMT filter(s) could be placed at the top section of an enclosed settling chamber, allowing excluded particles to gradually fall out of the primary gas stream under the influence of gravity. Hoppers placed directly beneath the exclusion filter would collect particles ejected from the gas stream for subsequent recycling or disposal. Alternatively, if set up as a modified cyclone insert, the conventional cyclone design would allow removal of most of the particles (primarily the larger sizes down to 20 μ m). The BLMT filter, operating in

the upper core (just before the top exit) would provide secondary filtration of small particles, keeping particles above the critical cut-off size within the unit to be eventually swept away with the larger particles. Much lower maintenance costs, easier operation and less downtime for the filtration system are envisioned over conventional systems, since there will be no need to clean or replace fouled media.

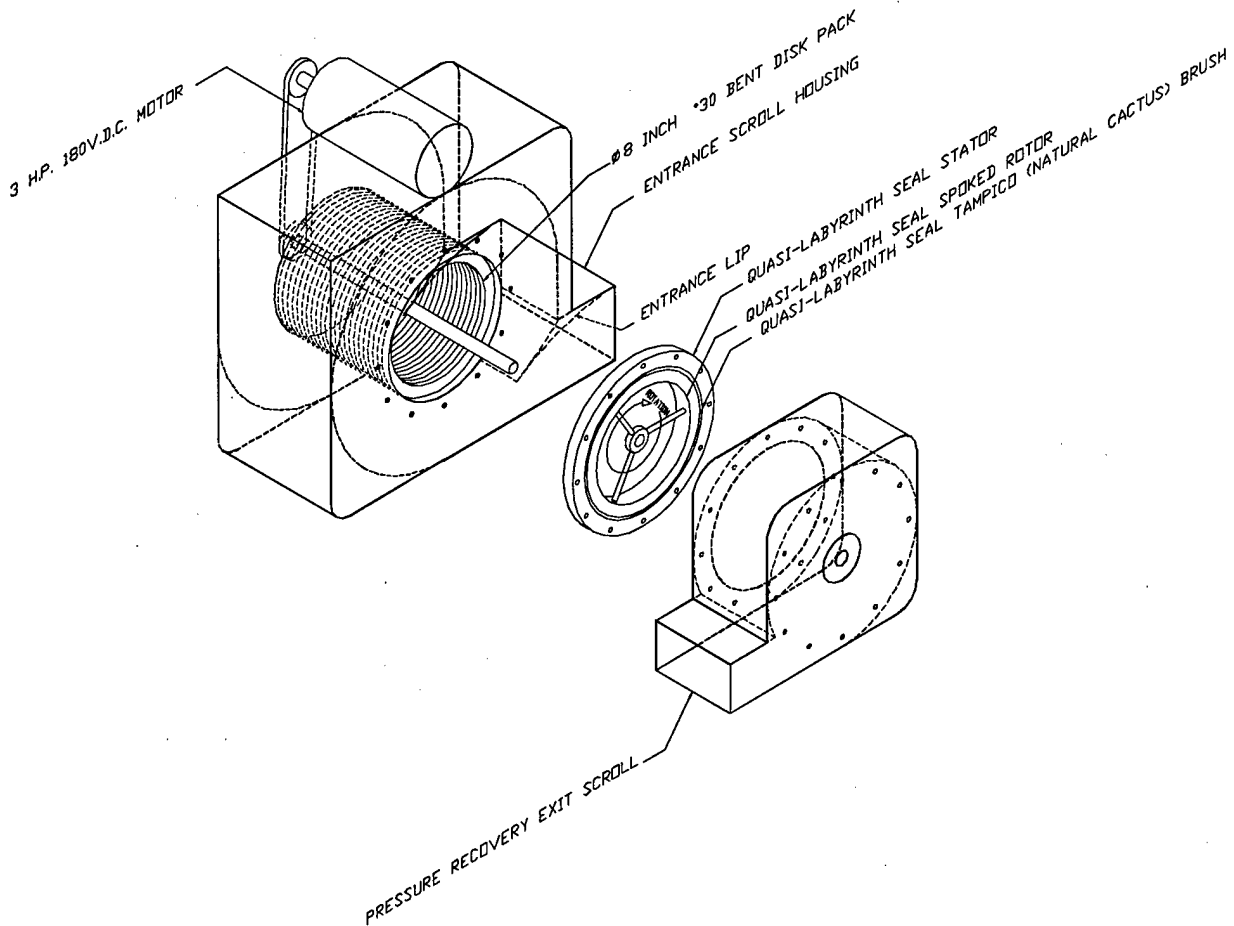

FIGURE 5. Schematic of an 800-ACFM BLMT Paint Overspray Arrestor Prototype

2.2 Theory Description

In previous investigations, InnovaTech generated a proprietary computer flow simulation code [12–14] to model flow characteristics of BLMT-based devices. Empirical validation is underway in concurrent DoD and DOE investigations [15, 16]. Computer simulation modeling using this proprietary code can therefore be performed in the laboratory to optimize particle separation efficiency while minimizing pressure drop across the device prior to actual prototype construction for many varied applications. The results of these investigations [12–16] (which use this concept as the basis for *solid* particle separation) establish several basic governing equations that BLMT filtration devices must follow from basic engineering principles. These equations neglect any effects due to the containment housing, assuming flow into the device is

radial (as opposed to tangential). First, the governing equation for approximating particle rejection (the critical cut-off diameter) in the BLMT exclusion filter [17, 18] was found to be

$$D_p \geq \frac{3}{R_o \omega} \sqrt{\frac{v \dot{M}}{dn \pi \rho_p}} \quad \text{Equation 1}$$

where

- \dot{M} is the mass flow rate,
- D_p is the critical particle diameter excluded,
- R_o is the outside radius of the filtration disks,
- ρ_p is the density of the particle,
- v is the kinematic viscosity of air ($v = \mu / \rho$, dynamic viscosity divided by density),
- ω is the rotational velocity of the disks,
- d is the inter-disk spacing, and
- n is the number of disk spaces in the filter.

The governing equation for approximating the pressure drop across the BLMT filter [17, 18] was found to be

$$P = \frac{\rho_g}{2} \left(\left(\frac{\dot{M}}{2 \rho_g \pi d n} \right)^2 \left(\frac{1}{R_o^2} - \frac{1}{R_i^2} \right) + 2(R_o^2 - R_i^2) \right) \quad \text{Equation 2}$$

where

- ΔP is the total pressure drop across the filter,
- R_i is the inside radius of the filtration disks, and
- ρ_g is the air density.

Equation 2 does not account for pressure drop due to the BLMT housing, which in high vorticity situations can dominate the actual pressure drop of the entire device.

Finally, the equation defining the velocity of the gas entering the perimeter of the filter [17, 18] was found to be

$$V_g = \frac{\dot{M}}{2 \pi d R_o} \quad \text{Equation 3}$$

where

- V_g is the velocity of the incoming gas (at the entrance).

With respect to Equation 1, where the critical particle cut-off size (D_c) is defined as a function of operational and geometric parameters, if the only variable that is experimentally changed is the rotational velocity of the disks (ω), then this equation can be expressed as

$$D_c \geq \frac{KC_f}{\omega} \quad \text{Equation 4}$$

where

C_f is the theoretical-to-empirical correlation coefficient, and
 K is the effect of all other parameters.

For example, for the fractional efficiency data shown in Figure 15, an empirical particle cut-off size can be approximated at 5-percent penetration (*i.e.*, 95-percent separation efficiency), which is presented in Table 1. If the appropriate BLMT parameter data is input to Equation 1, then theoretical particle cut-off sizes can be generated at three disk spin rates, as seen in Table 1. Dividing the theoretical particle cut-off size by the empirical particle cut-off size provides the correlation coefficient (C_f).

Disk Velocity (RPM)	Disk Velocity (radians/sec)	1/ω	Theoretical D_c (in μm)	Empirical D_c (in μm)	C_f
5,000	523.6	0.00191	1.83	1.8	1.02
2,000	209.4	0.00478	4.57	2.7	1.69
1,500	157.1	0.00637	6.09	3.0	2.03

TABLE 1. Theoretical vs. Empirical Particle Cut-Off Sizes for Various Spin Rates for a Specific BLMT Filter/Housing Combination.

Plotting the correlation coefficient (C_f) as a function of BLMT disk velocity (ω) yields a near-linear relationship that describes the anticipated particle cut-off size with that experimentally measured, as exhibited in Figure 6. There are two lines plotted: (a) where the particle cut-off size is defined as 5 percent penetration (95 percent filtration efficiency) and (b) where the particle cut-off size is defined as 50-percent penetration (50-percent filtration efficiency). The slopes and y-intercepts of these lines represent a specific empirically-derived geometric BLMT filter/housing combination operating at only one volumetric flow rate (use of either plot depends on the definition of particle cut-off size utilized).

Establishing at least two empirical cut-off sizes for the BLMT filter at different spin rates (preferably intervals above 2,000 RPM) appears to provide a relatively accurate measure of the actual performance of the device in relation to its predicted behavior. The coefficient would take into account the influence of the housing, as well as possibly particle loading and other dependent variables. InnovaTech has not performed enough testing yet on various BLMT prototypes (different disk sizes, shapes, flow rates, etc.) to fully explore all of the ramifications of this correlation. For example, how would the slope of this line change as influenced by disk size over the same spin velocity range and volumetric flow rate? Is it always linear? This will be exploited further in subsequent investigations, since this type of data was generated only during the late stages of this study.

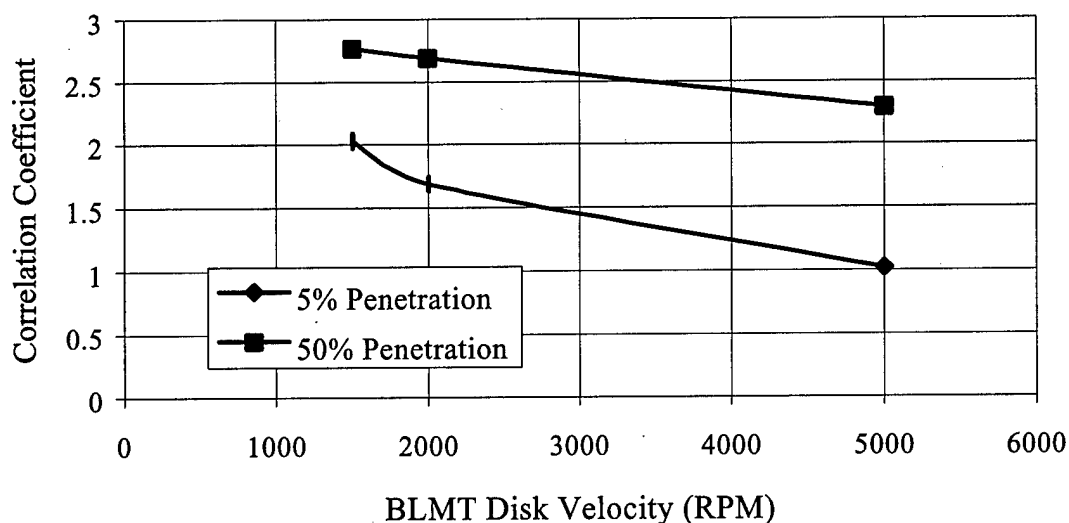

FIGURE 6. BLMT Correlation Coefficient vs. Disk Spin Rate

2.3 Regulatory Requirements

For the technology to be acceptable to the military for retrofit on existing DoD paint spraying operations, at a minimum the BLMT particle filter must meet the Aerospace NESHAP, which utilizes EPA Method 319 [3, 6] as the basis for determination of filtration efficiency compliance for both liquid and solid overspray particles. The current method of compliance for aerospace overspray uses particle *weight* arrestance, which does not provide information on the control of respirable-size aerosol particles in the 0.1-to-10- μm size range (refer to Fig. 1). Method 319 does not utilize aerospace paint aerosols for testing compliance, but instead uses polydisperse challenge aerosols of potassium chloride (KCl) as the solid phase and oleic acid as the liquid phase. Accordingly, to meet the new Aerospace NESHAP emissions criteria [3] will require paint overspray arrestors to have minimal fractional efficiencies as a function of aerodynamic particle sizes as set forth in Table 2 (for *existing* aerospace painting facilities) [3, 6].

	Filtration Efficiency, percent	Aerodynamic Particle Size, μm
Liquid Phase	>90	>5.7
	>50	>4.1
	>10	>2.2
Solid Phase	>90	>8.1
	>50	>5.0
	>10	>2.6

TABLE 2. Minimum Filtration Efficiencies as a Function of Aerodynamic Particle Size for compliance with the 1998 Aerospace NESHAP (Existing Facilities) [6]

The filtration efficiencies for the Aerospace NESHAP allow the use of a typical two-stage paint arrestor for minimal compliance at existing paint facilities. Figure 7 illustrates typical two-stage

arrestor efficiency curves. As can be seen in the efficiency curves for the two-stage arrestor, the minimum NESHAP efficiencies of Table 2 are just to the right along the entire (typical) S-shaped efficiency curves for both solid and liquid aerosols.

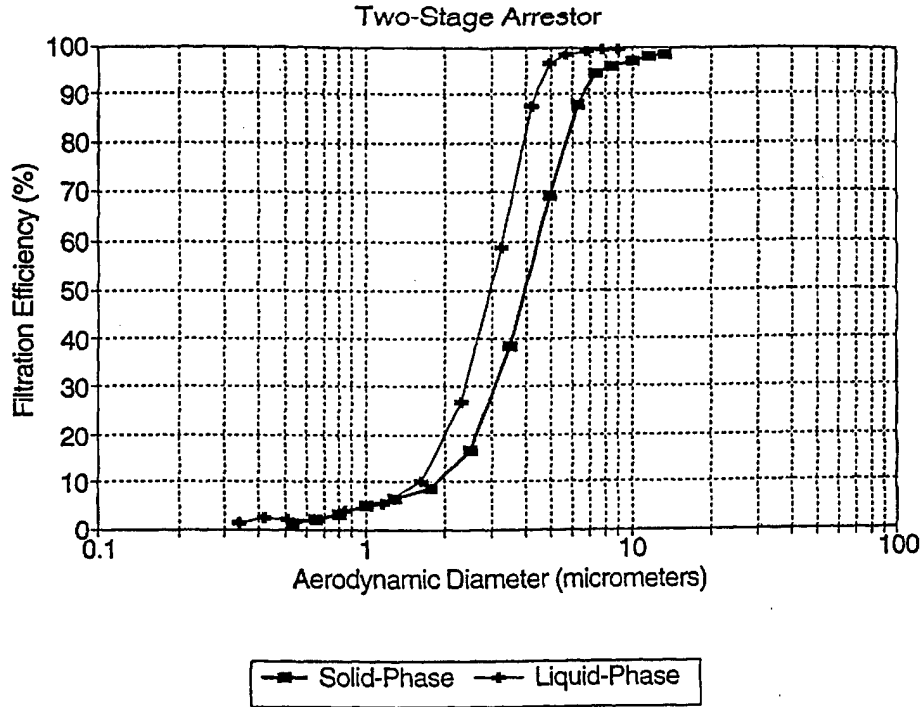

FIGURE 7. Fractional Filtration Efficiency as a Function of Aerodynamic Particle Diameter for a Typical Two-Stage Paint Overspray Arrestor [6]

The Aerospace NESHAP requires much higher particle filtration efficiencies for *new* aerospace painting facilities (*i.e.*, those constructed after September 1, 1995) as set forth in Table 3 [6], thus requiring these paint operators to use the equivalent of three-stage paint overspray arrestors to be in regulatory compliance.

	Filtration Efficiency, percent	Aerodynamic Particle Size, μm
Liquid Phase	>95	>2.0
	>80	>1.0
	>65	>0.42
Solid Phase	>95	>2.5
	>85	>1.1
	>75	>0.70

TABLE 3. Minimum Filtration Efficiencies as a Function of Aerodynamic Particle Size for Compliance with the 1998 Aerospace NESHAP (New Facilities) [6]

3. PHASE I TECHNICAL OBJECTIVES

The specific objectives of the Phase I work were to

- Modify an existing BLMT exclusion filter used for solid particulate separation to accommodate sticky, liquid aerosol paint particles under relatively high volumetric flow rate conditions,
- Empirically evaluate the device in terms of particle removal efficiency and pressure drop,
- Determine inlet and outlet particle size distributions of representative paint samples,
- Demonstrate (via the prototype) scale-up of the device over current flow rates,
- Establish an adequate sludge collection/removal technique that mitigates sticky particle build up on any of the critical prototype components,
- Estimate the cost/ACFM for the module.

The specific questions that were addressed in Phase I were

- What is the change in particle separation efficiency and pressure drop as a function of volumetric flow rate and rotational speed of the disk pack with the modified prototype?
- Can empirical data from the prototype be used to modify the proprietary computer flow simulation model to optimize flow parameters for larger scale devices?
- What are the inlet and outlet size distributions of representative particles tested on the filter?
- What is the highest volumetric flow rate that can be achieved in the prototype and still maintain PM_{2.5} compliance?
- Can sticky particle build-up be mitigated or eliminated within the BLMT exclusion filter by (a) choice of materials of construction and/or (b) upstream humidity/moisture enhancement and/or (c) manipulation of the flowstream through the device?
- Will the modular prototype offer quantifiable advantages over conventional filtration systems in terms of the potential reduction in maintenance and downtime costs?
- Can a larger-scale BLMT exclusion filter be designed to be incorporated into an existing military paint spraying operation without extensive re-engineering?
- What is the best method (cyclone, drop bin, involute housing, etc.) and choice of materials to remove sticky paint particles/sludge to a collection vessel for disposal or recycling?
- What is the approximate anticipated cost per ACFM of a scaled-up BLMT device?

For reasonable filtration parameters and operating conditions, this unique filter technology can be used to efficiently remove particles from numerous airflow streams. Operational BLMT improvements developed during the course of related BLMT development projects [12, 16] are applied to the solution for this project. Examples include the tangential inlet flow housing developed to increase separation efficiency and the inlet flow lip that enhances the airflow vortical structure in the housing.

4. EXPERIMENTAL RESULTS

Five tasks were delineated in the project to accomplish the Phase I objectives. The objectives included tasks associated with development of a PM_{2.5}-compliant filter for this application. As indicated earlier, recent contacts with EPA and industry organizations indicate that PM_{2.5} emission requirements are expected to soon augment the current PM₁₀ regulations. A task summary is provided below in tabular form:

Task 1	Modify a solid particulate BLMT filter to allow sticky liquid aerosol filtration at high volumetric flow rates.
Task 2	Measure particle separation efficiency and pressure drop as a function of operational and design parameters.
Task 3	Experiment with materials of construction, gas flow channeling and upstream moisture/humidity control to enhance sticky liquid aerosol capture and removal efficiencies.
Task 4	Contrast BLMT filtration economics and potential environmental impact with conventional paint overspray filtration technologies.
Task 5	Prepare a comprehensive <u>Final Report</u> covering all Phase I activities with recommendations for Phase II continuation.

TABLE 4. Summary of Phase I Tasks

The tasks are discussed in the following sections.

4.1 Task 1

Modify a solid particulate BLMT filter to allow sticky liquid aerosol filtration at high volumetric flow rates.

Test Setup

BLMT filters previously used in solid particulate matter applications were modified to accommodate sticky liquid aerosol paint overspray using two different design scenarios and two different (respective) flow rates: 100 ACFM and 800 ACFM. Figure 8 presents a schematic of the BLMT paint overspray experimental setup. The following narrative provides an overview of

preliminary test results and the rationale in design changes and experimental set-up for both units.

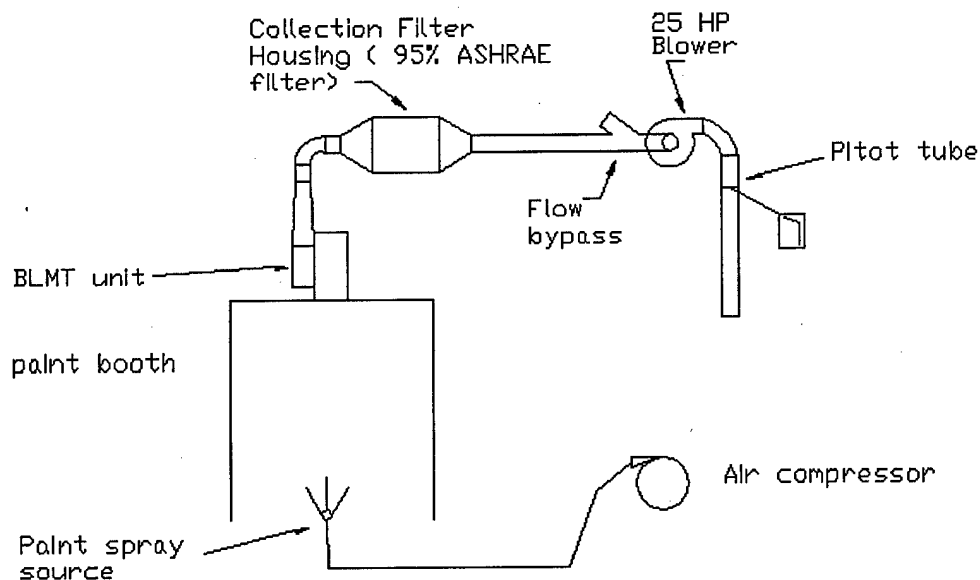

FIGURE 8. Schematic of the BLMT Paint Overspray Experimental Setup

Paint and Primer Evaluation

Preliminary aerosol testing consisted of spraying, collecting, and analyzing the aerosol primer and paint samples (supplied by Tyndall AFB) to visually confirm anticipated particle size ranges generated from a high-volume, low-pressure (HVLP) paint gun. Under simulated spray painting conditions, the primer and paint were (separately) sprayed into a 4-foot x 4-foot x 8-foot paint spray booth for the purpose of collecting typical overspray samples on scanning electron microscope (SEM) specimen pedestals located in the rear of the booth.

The primer adhered to the specimen pedestals as particles, and provided sufficient samples to permit viewing, photography, and further evaluation. The primer overspray particles ranged in size from submicron to tens of microns in diameter. Figure 9 presents an SEM photomicrograph of several large primer particles captured on a specimen pedestal. The paint sprayed into the booth during this step tended to coat the specimen pedestals rather than deposit on them as particles, and both visual and SEM examinations of paint particles were not particularly revealing in this step.

Following the SEM evaluation, energy dispersive x-ray (EDX) analyses were performed on samples of both the primer and paint to determine the presence of chromium. Substantial chromium content was present in the larger primer particles. Detection for chromium content in smaller primer particles (those less than 6- μm) was limited by EDX analyzer beam width, so this analysis was unable to determine the smallest particle size to exhibit chromium content. EDX analysis of the paint samples was once again unrevealing due to the manner in which the paint coated the specimen pedestals.

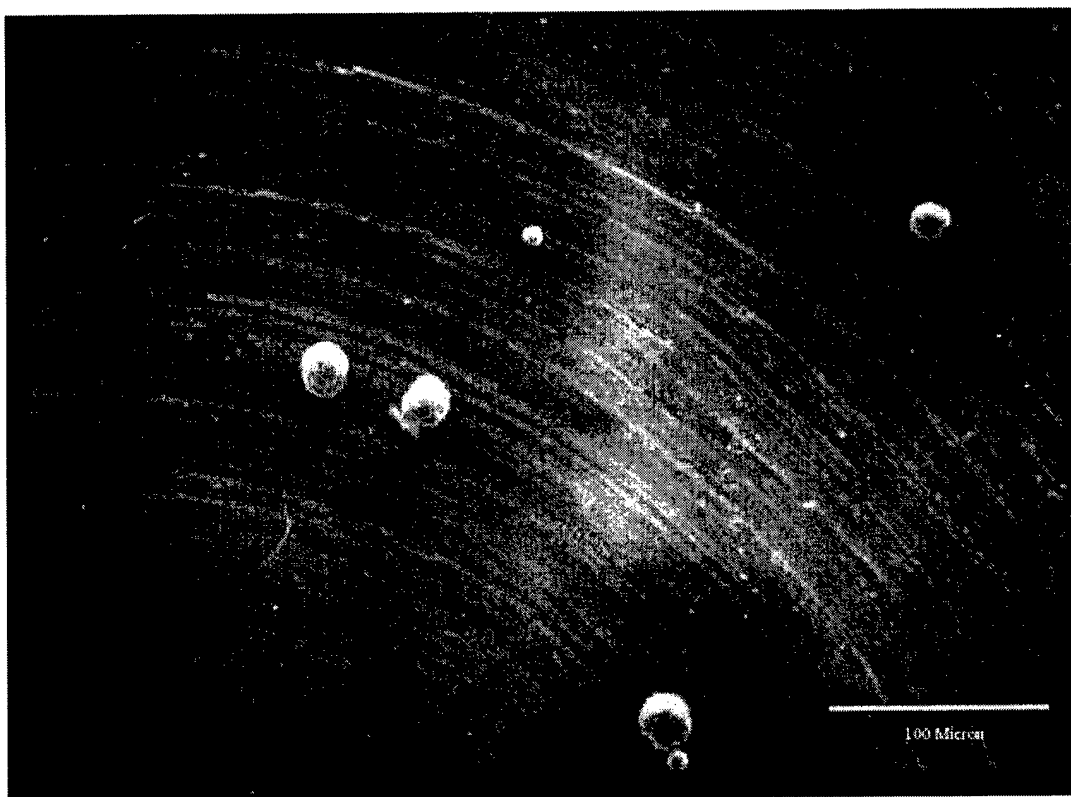

FIGURE 9. SEM Photomicrograph of Several Primer Overspray Particles at 110X Magnification

A target filter cut-off size was required to establish initial BLMT filter design parameters. Since SEM and EDX analyses were unable to conclusively determine the minimum cut-off size for chromate-containing particles, a literature search was conducted to identify prior work in this area. Research of recent publications related to measurement of aerospace coating (both primer and paint) chemical and physical properties yielded recent technical papers by Michael Stolle (Air Technologies, Inc.) [21, 22]. The minimum size aerosol particle containing toxic chromates is typically on the order of 1 to 2 μm . Presuming a thin (approximately 0.5- μm) primer or paint coating surrounds these small hexavalent chromate particles during spraying operations, we have assumed that a minimum primer or paint hazardous particle size is on the order of 2.5 μm . This is the basis for our established target BLMT filter cut size of 2.5 μm . Note that this also corresponds to the anticipated requirements for compliance with EPA's PM_{2.5} emission regulations.

Figure 10 was generated from the Stolle [21, 22] data for paint pigments produced by Wayne Pigment Corporation of Milwaukee, Wisconsin, and analyzed by Particle Data Laboratories, Ltd. of Elmhurst, Illinois. This figure shows a typical cumulative particle size distribution of strontium chromate pigment suspended in aerospace paints, showing both count (number) and volume distributions. Statistical analysis of the count distribution curve established a median particle size of 2.622 μm , while the volume distribution curve established a median particle size of 4.156 μm .

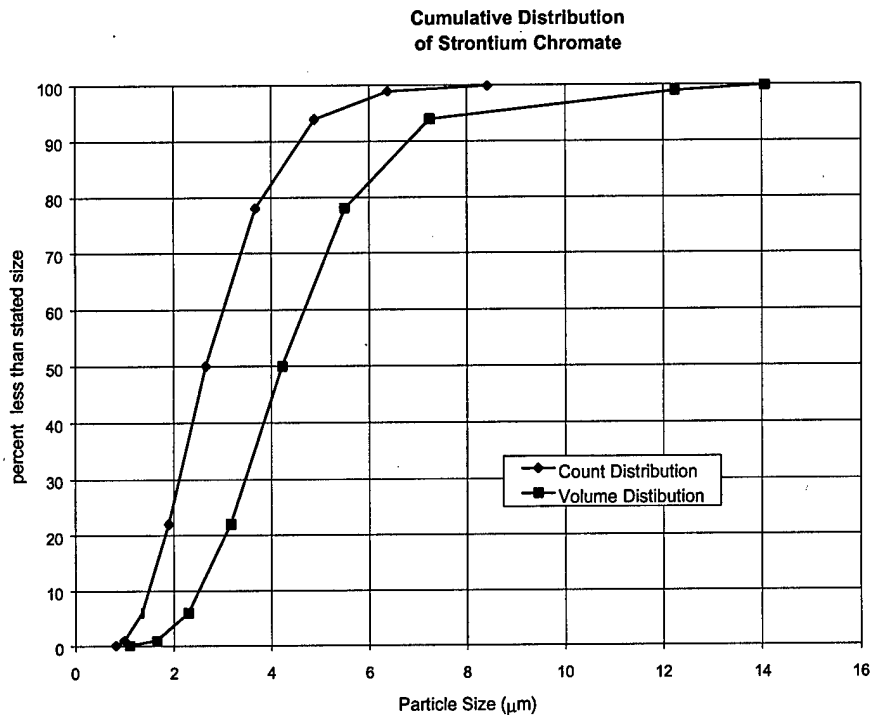

FIGURE 10. Typical Cumulative Size Distributions of Strontium Chromate Particles Suspended in Aerospace Paints, Showing Count and Volume Distributions [21, 22]

100-ACFM Filter Discussion

The first BLMT test performed as part of this task involved use of an existing 100-ACFM disk pack and external plenum. This test relied entirely on BLMT effect to separate paint particles from airflow, because the particles approached the rotating disk pack along radial flow lines in a relatively large open plenum. Some of the particles were large enough to settle out in the plenum under the influence of gravity before they reached the disk pack, and the remainder attempted to enter the rotating disk pack. This disk pack used flat disks eight inches in diameter with a 5.5-inch-inner-diameter plenum. The purpose of this test was to observe paint spray behavior when exposed to BLMT flow activity and subjectively gage filtration/separation effectiveness. No attempt was made to measure BLMT filtration efficiency in this step. Further testing with mass-based efficiency evaluations were planned for later experiments. Fractional efficiency evaluations using optical time-of-flight calculation laboratory equipment or laser particle measurement were not practical with the equipment available in the InnovaTech laboratory during this step.

These early experiments highlighted an area of concern for sustained long-term operation of the device with sticky particles. In the 100-ACFM configuration, it was observed that airborne particles constantly challenge the BLMT device (*i.e.*, there was no active extraction of the excluded particles away from the perimeter entrance of the device). In operation, the suspended aerosol particles surrounded the device and constantly attempt to penetrate between the disks when following the fluid flow lines. This observation has driven the development of a housing

to facilitate tangential air flow around the BLMT disk pack (termed “spin-up”) while at the same time providing a means for collecting particles that are excluded from the flow.

The disk pack for the 100-ACFM unit was modified to include a group of 30 (out of 100) disks covered with Teflon™ thin film coatings. The purpose of this was to compare the rate of sticky paint deposition on disks treated to exhibit high contact angle (*i.e.*, low affinity for adherence) to those fabricated from conventional materials (*e.g.*, stainless steel or aluminum). Less deposition would confirm reduced or eliminated potential for clogging or bridging of the spaces between the disks during operation. As anticipated, there were fewer instances of paint particle deposition on the Teflon™-coated disks than those uncoated, but deposition was not completely eliminated. The amount of build-up on the disks was observed to be a function of disk rotational speed; higher disk speed resulted in reduced build-up (which, again, was anticipated). Operational and geometric parameters for this device are delineated in Table 5.

Design Parameters	Parameter Values (for 2.5 μm filter)
No. of Disks in Disk Set	100
Disk Spaces (n)	99
Intra-Disk Spacing (d)	1.0 mm = 1.0 x 10 ⁻³ m
Disk Thickness	0.762 mm = 7.62 x 10 ⁻⁴ m
Disk Outside Radius (R _o)	4 inches = 0.1016 m
Disk Inside Radius (R _i)	2.75 inches = 0.0699 m
Particle Density (ρ _p)	2.25 g/cm ³ = 2250 kg/m ³
Density of the Gas (ρ _g)	1.1 kg/m ³
Angular Velocity (ω)	4,000 RPM (419 radians/sec)
Mass Flow Rate (Ṁ)	100 CFM = 0.0472 m ³ /sec 0.0472 m ³ /sec = 0.052 kg/sec
Dynamic Gas Viscosity (μ _g)	1.8 x 10 ⁻⁵ kg/m sec

TABLE 5. Test Parameters Used in the 100-ACFM BLMT Overspray Filter

In the last year, InnovaTech has performed several comparable filtration or particle penetration tests on BLMT prototype filters in the 100-ACFM range [16]. These tests have included filtration of a variety of dry, solid particles, such as ISO-UltraFine test dust, and liquid mists, such as aerosolized vegetable oil or oleic acid. This data is presented here due to the general similarity of the tests, identified BLMT behavior, and comparable anticipated results.

Testing with ISO-UltraFine test dust resulted in BLMT size distributions that were highly dependent on the rotational spin rate. Figure 11 presents ISO-UltraFine test dust filtration (cumulative particle size distribution) as a function of particle size for a selection of BLMT disk pack spin rates. Figure 12 presents similar size distribution results for aerosolized vegetable oil tests.

**Cumulative Particle Size Distributions
of ISO-UltraFine Dust Penetrating the BLMT Filter**

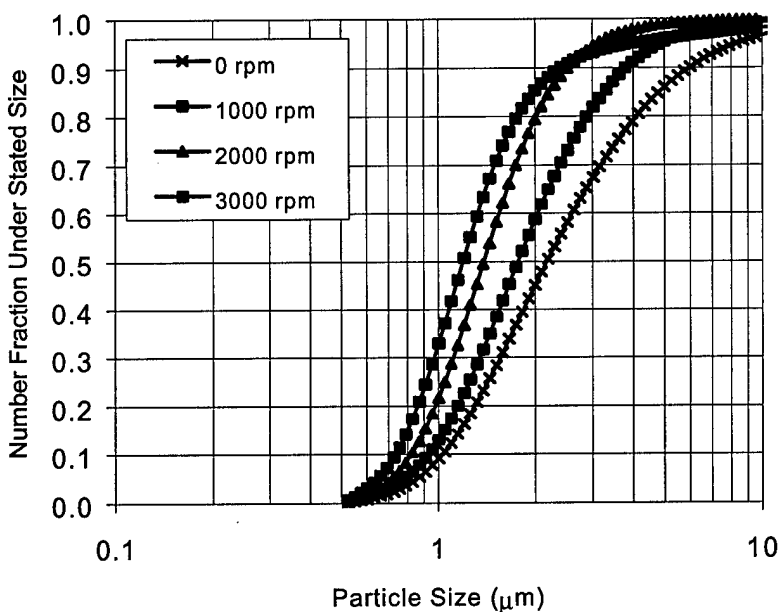

FIGURE 11. BLMT Particle Size Distributions for ISO-UltraFine Dust as a Function of Aerodynamic Particle Size for Various Disk Spin Rates

**Cumulative Particle Size Distribution of Vegetable Oil
Penetrating the BLMT Filter**

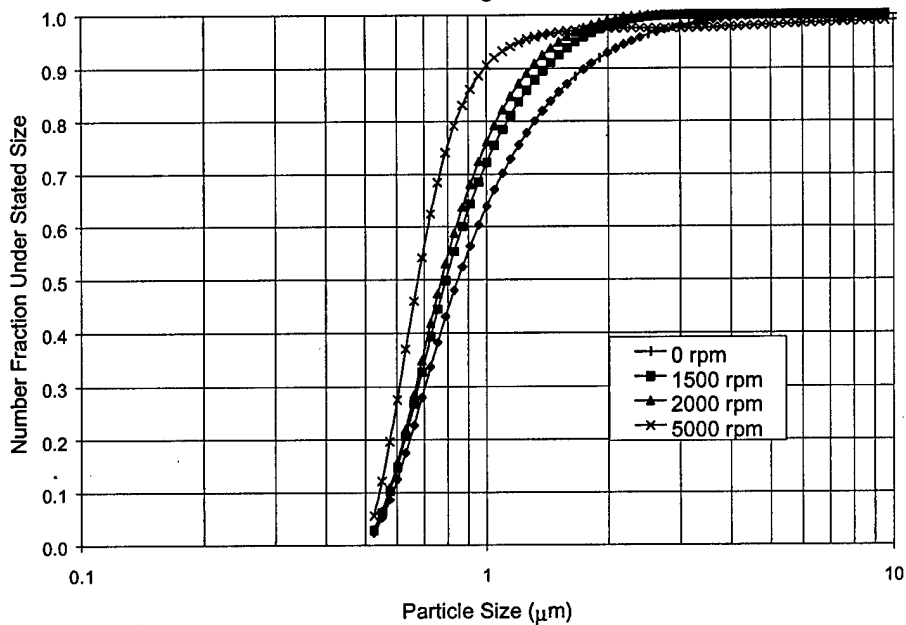

FIGURE 12. BLMT Particle Size Distributions for Vegetable Oil as a Function of Aerodynamic Particle Size for Various Disk Spin Rates

800-ACFM Filter Discussion

As previously mentioned, the scaled-up 800-ACFM prototype was assembled from a BLMT unit formerly used as a solid particle filter. It was modified as necessary to address the issues and difficulties encountered with the 100-ACFM unit, which were primarily the channeling of flow towards the BLMT disk pack and collection of paint solids. Figure 5 presents a drawing of the high-flow prototype, showing the scroll housing with the flow conditioning lip, the disk pack, the seal and rotor combination, and pressure recovery exit scroll.

As discussed earlier, during normal operations, rejected particles orbit the disk pack. In this case, 2.5- μm and larger aerosol particles orbit the pack and eventually coalesce as a result of particle interaction. As the individual particles increase in size and mass the orbit will eventually expand until contact with the housing side occurs, and the particle no longer challenges the disk pack. During paint overspray collection tests, the paint solids were allowed to pool in the bottom of the scroll housing, which was large enough to permit collection of a substantial volume of the paint solids.

The BLMT disk pack incorporated disks of the same dimensions as the 100-ACFM disk pack, except they were bent at a 30-degree angle to assist with wet/sticky paint particle removal. The particle force diagram illustrated in Figure 1 illustrates a flat disk arrangement where the drag force on each particle is opposed by the centrifugal force developed by transfer of momentum from the boundary layer to the particle. In a bent disk arrangement the drag force is factored by the sine of the inclined angle, and the other component of drag is directed into the adjacent disk boundary layer. It was felt this disk arrangement would further prevent particles from landing on and attaching to the disks.

The individual disks in the 800-ACFM disk pack were not treated with TeflonTM for this series of tests. It was felt that concept feasibility had been demonstrated with the 100-ACFM disk pack, and required no further demonstration. This design attribute will be examined and studied in the follow-on Phase II project.

Figure 13 presents a photograph of the BLMT bent-disk pack mounted on a one-inch solid shaft rotor. The 8-inch diameter disk pack and exhaust port are shown. Discussions under Tasks 2 and 3 further describe both the BLMT paint overspray collection filter and the results of performance tests.



FIGURE 13. 800-ACFM BLMT Disk Pack With Exhaust Port

4.2 Task 2

Measure particle separation efficiency and pressure drop as a function of operational and design parameters.

This Phase I project successfully demonstrated feasibility of BLMT filtration as a means to capture paint overspray collection and minimize waste products generated at Air Force aircraft maintenance facilities. Filtration efficiency was determined through mass balance. Particle size fractional efficiencies will be developed during the follow-on Phase II project.

The following summarizes InnovaTech's most successful high-flow paint overspray test. The test was arranged in the manner schematically presented in Figure 7. The paint booth, connecting ductwork, and BLMT housing were all lined with contact paper to collect deposited paint spray. The paper lining was weighed prior to the test to take into account the effects on the mass efficiency calculation. During this test, a volume (705 grams) of Air Force-issued paint was released into our paint booth using a standard HVLP spray gun over a period of 35 minutes. The aerospace paint was composed of 36.3 percent solids, with the remainder being VOCs, so 255.9 grams of solids were sprayed during the test. Approximately 36 grams of the solids (14 percent of solids) were deposited on spray booth interior surfaces, never making it to the BLMT

filter inlet. This left 219.9 grams of paint solids left to challenge the BLMT device. Upon completion of the test, the downstream media filter (a 95-percent-efficient ASHRAE filter) had increased in weight by 7.5 grams, resulting in an efficiency of 96.6 percent by weight. Post-test visual inspection revealed light coatings of paint on various BLMT components. These included the exhaust bell, which seemed to have the highest coating concentration, and the inside (dirty-side) brush seal, which had the next highest coating concentration. Finally, the BLMT disk pack itself had an extremely light coating just on the outer edges of the disks.

One post-test concern was the weight increase registered by the ASHRAE filter, because visual inspection yielded no trace of paint solids. One possible explanation was the filter media absorbed a quantity of the VOC. Weighing the same filter a month later showed an overall weight loss of 3 grams from the post-test measurement. Assuming this circumstance to be due to post-test VOC off-gassing, the net filter weight gain due to particle collection was 4.5 grams, resulting in BLMT filtration of approximately 98 percent by weight.

Particle size fractional efficiency testing during the follow-on Phase II project will include use of API AeroSizer™ particle-sizing equipment with isokinetic sampling and an MIE laser particle counter downstream (for dilute loading). The API measures aerodynamic aerosol particles ranging in size from less than 1 μm to greater than 200 μm via conventional time-of-flight data evaluation, but will require additional special additional optical equipment to perform these measurements on paint particles.

Pressure drop across the device was assessed with traditional differential pressure gages and manometers. Establishing a disk pack spin rate and varying the flow rate through the 800-ACFM filter permitted development of a series of pressure drop curves. This was performed for spin rates between 1,500 and 5,000 RPM, in addition to a reference curve developed for zero rotation. Figure 14 presents the results of this effort, and graphically demonstrates the pressure drop increase that accompanies increased spin rate. Work to date on this and other projects clearly indicate that particle removal efficiency increases with disk pack spin rate, and the energy penalty in the form of pressure drop across the device increases as well. Follow-on Phase II project emphasis will be placed on optimizing the design to maximize particle removal efficiency and minimize pressure drop for a given flow rate capacity.

**Pressure Drop vs. Flow Rate
8 Inch BLMT
2nd Design**

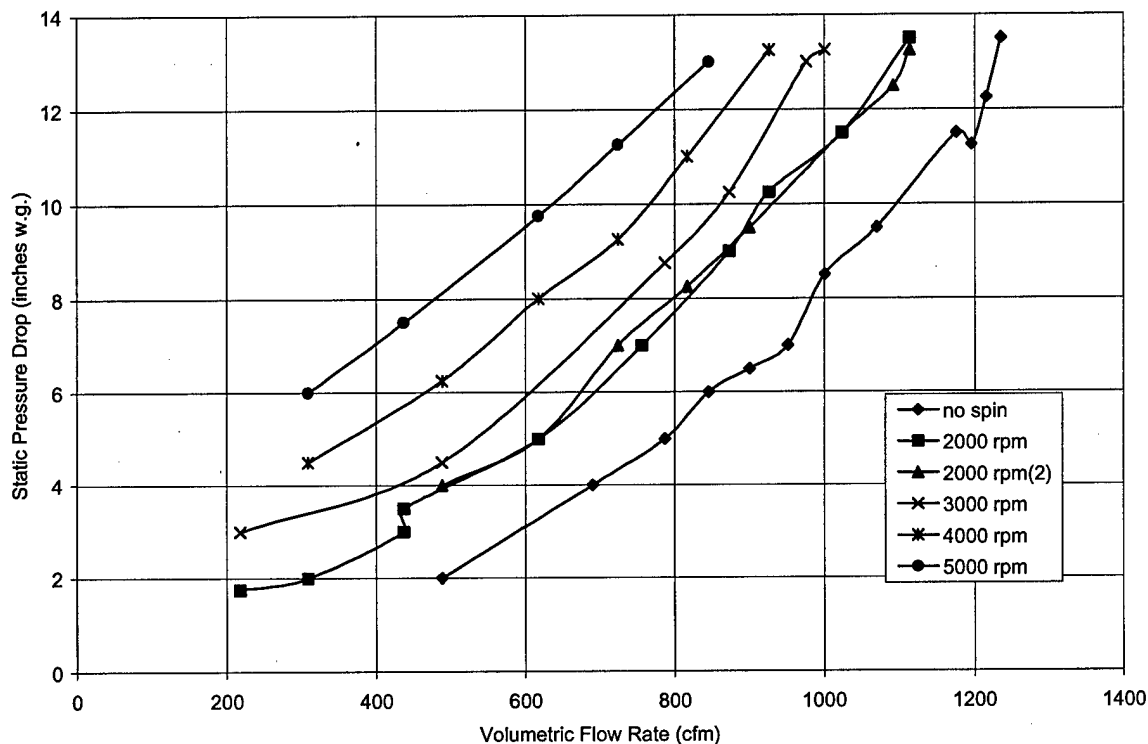

FIGURE 14. Pressure Drop vs. Flow Rate for the 800-ACFM BLMT Filter at Incremental Disk Spin Rates

As explained earlier in this report, modifications and additional components will be required before using InnovaTech's existing laboratory equipment for particle size measurement, evaluation, and fractional efficiency determination. This effort will be included in the follow-on Phase II project. Figure 15 presents fractional efficiency curves resulting from a low-flow test of an 8-inch diameter BLMT filter for removal of aerosolized vegetable oil. The data presented in this figure are felt to be representative of the paint behavior, and are included here for information purposes. This is also representative of the paint arrestor performance data required to meet EPA Method 319 test requirements [6].

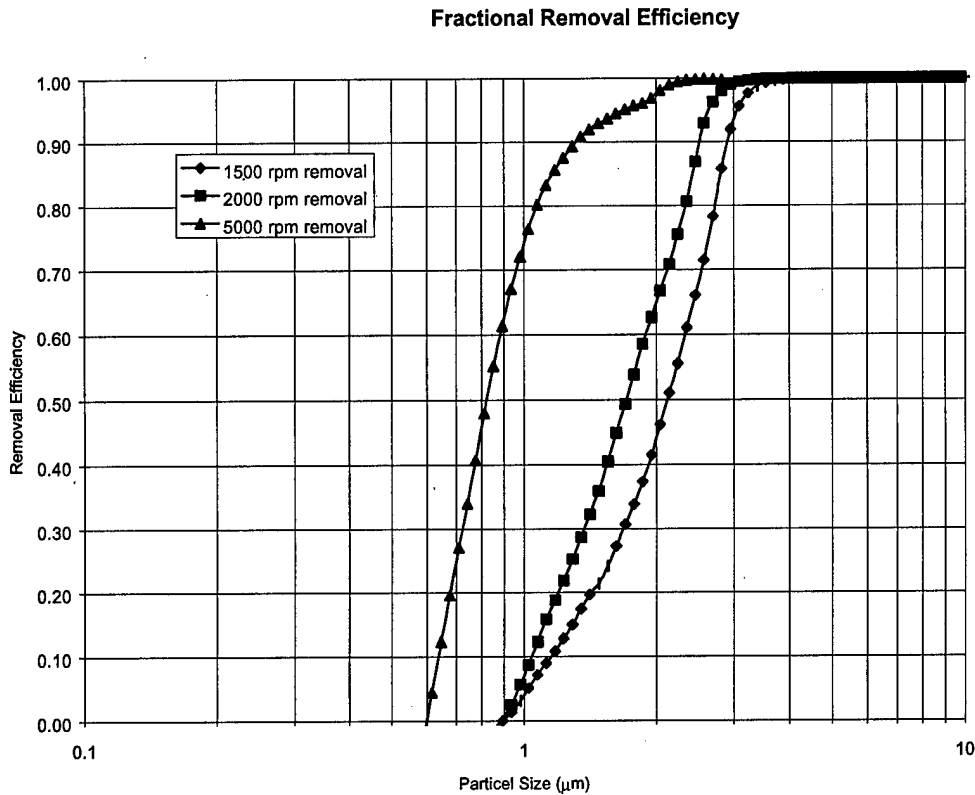

FIGURE 15. Fractional Filtration Efficiency vs. Particle Size for Various Disk Spin Rates at Constant Volumetric Flow

4.3 Task 3

Experiment with materials of construction, gas flow channeling and upstream moisture and humidity control to enhance sticky liquid aerosol capture and removal efficiencies.

The intention of this task was to allow for experimental variations of components and/or design of the 800-ACFM BLMT filter. The bases for these variations included the results of the initial testing with the 100-ACFM filter and experience in other projects [12, 14].

Coatings

As discussed in Task 1, one-third of the disks in the 100-ACFM disk pack were coated with Teflon™ to minimize adherence of paint to the disk pack. The purpose of this Phase I experiment was to determine the feasibility or usefulness of such coatings on BLMT filter components.

In an early test of Teflon™-coated materials, paint was deposited and checked for adherence as the paint began dried. Adherence was minimal as the paint cured from wet to sticky or tacky. After drying overnight, the paint was found to stick tenaciously on the Teflon™ coating. Similar tests were performed on polymeric materials (e.g., HDPE) because they are considered

candidates for future disk pack fabrication. This material did not provide a sufficiently non-stick surface for the very tacky paint aerosol particles, as adherence was quite strong. The use of Teflon™ coatings on the inside surface of the BLMT scroll housing will be considered in our follow-on Phase II project as a means to enhance paint overspray residue collections.

Gas Flow Channeling

Gas flow channeling was implemented in several areas of the 800-ACFM filter. The air entry of the housing uses a lip to direct flow in a circular path adjacent to the housing wall around the disk pack. Without this lip, the filter housing inlet opening permitted particle-laden airflow to immediately challenge the disk pack. As discussed in Task 1, the housing facilitates particle collection by encouraging coalescence of paint particles as they orbit the disk pack. The inlet lip channels the flow towards the housing wall, encouraging the individual paint particles to circle the pack for at least a single orbit before the drag force pulls them toward the edges of the rotating disk pack.

The implementation of a bent disk design was presented in Task 1. Analysis related to concurrent BLMT projects in other application areas showed that a bent disk arrangement would provide higher separation efficiencies (*i.e.*, smaller particle cut-off sizes) under identical flow and spin rates than those obtained using flat disks [15, 16]. The bent disks contribute to gas flow channeling by directing the flow at an entrance angle greater than 90 degrees. In addition to the explanation of particle free body forces given in discussion for Task 1, the sharp entrance angle provides an opportunity for inertial separation of aerosolized particles from the airflow.

The final opportunity for gas flow channeling relates to the treatment of air exiting the BLMT filter. Air exits the disk pack as a focused and compact vortex. Our experience with alternate BLMT filter sizes and configurations in concurrent Army and DOE investigations [15, 16] has led to development of a pressure recovery exhaust housing that directs and organizes the exiting gas into a more stable flow field. This device has exhibited as much as 60-percent pressure recovery when compared to just exhausting to ductwork and a downstream blower [15]. Figure 16 presents pressure drop data collected on a larger BLMT unit to demonstrate the energy recovery associated with the housing. A 12-inch diameter disk pack was operated with and without the pressure recovery exhaust housing, and the results were plotted as pressure drop versus flow rate. The follow-on Phase II project will further optimize this BLMT component.

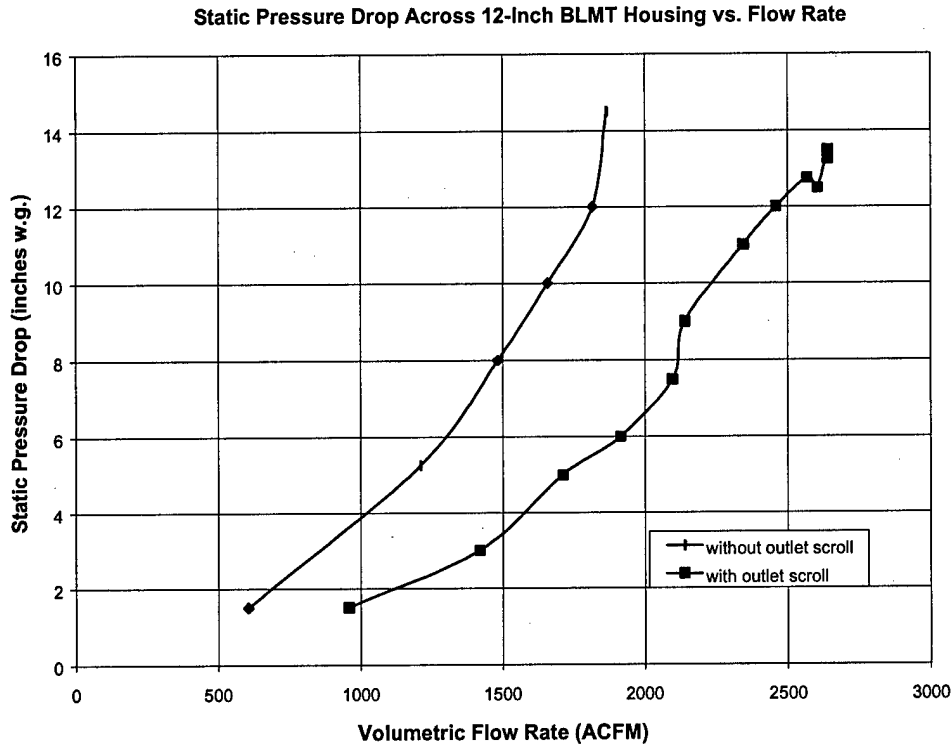

FIGURE 16. Pressure Recovery Using a BLMT Exit Scroll

4.4 Task 4

Contrast BLMT filtration economics and potential environmental impact with conventional paint overspray filtration technologies.

BLMT filter attributes were used to evaluate the device with respect to existing conventional filtration equipment, specifically media-based panel filtration systems. It was deemed that water-curtain filtration systems could not be adequately compared without much more data collected on their waste disposal systems. With the physical dimensions of the BLMT filter defined for two separate maximum air flow throughput ratings (*i.e.*, 2,500 ACFM and 25,000 ACFM), a modular set of BLMT units can be grouped together to provide a convenient "common ACFM threshold" for comparative purposes. A representative BLMT filter can then be compared with other similarly sized military or industrial emission control techniques for PM_{2.5} compliance. By making assumptions about the type of materials for construction of the device, the weight of the device and its physical size, with appropriate assumptions for larger-quantity production, the approximate cost for fabrication of similar units can be estimated. An Appendix to this report summarizes these assumptions and provides the basis for all economic calculations and comparisons. Initial capital acquisition of the 2,500-ACFM BLMT system was estimated to cost approximately \$8K, while the 25,000-ACFM was projected to be around \$80K. An overview of the estimated annual operational cost (including disposal cost) for both the BLMT and conventional systems is presented in Table 6. It is projected that the capital cost of the BLMT filter systems would initially be over ten times the cost of comparable conventional

media-based systems, but the annual operational costs would be significantly lower (by approximately three times), assuming equivalent or higher performance levels.

Capacity	Description	Conventional Spray Booth	BLMT Unit
2,500 CFM	Energy Cost	501.30	2,807.28
	Filter/Media Cost plus Disposal	16,648.50	407.88
	Paint Residue Disposal	5,040.00	5,040.00
	Annual Operating Cost	\$ 22,189.80	\$ 8,255.16
25,000 CFM	Energy Cost	2,005.20	12,532.50
	Filter/Media Cost plus Disposal	166,485.00	3,708.00
	Paint Residue Disposal	50,400.00	50,400.00
	Annual Operating Cost	\$ 218,890.20	\$ 66,640.50

TABLE 6. Annual Cost Comparison Summary for Conventional Three-Stage and BLMT Paint Overspray Filters

As explained in the Appendix, comparative costs for operation of each type of filter were approximated, including a breakdown for typical filter media costs, estimates of change-out frequency, disposal costs for spent paint and media, irrespective of additional personnel costs for handling and contaminated filter panel removal. A qualitative (subjective) comparison can also be made for personnel safety or reduction in hazardous waste handling during routine maintenance/removal/repair operations for each filtration system; BLMT filtration has a distinct advantage in reduction of these HAZMAT personnel operations. Furthermore, an assessment in the potential reduction of the volume (and type) of hazardous waste generated by each filtration method was attempted. Preliminary quantification of the potential minimization of the environmental impact of USAF painting operations (if BLMT overspray collection methodology is implemented) was the primary objective of this task.

Table 7 provides a summary of the cost/ACFM for the BLMT when contrasted with a conventional three-stage media filtration system. First-year annual operating costs, which include the capital cost of overspray collection equipment, are 30 to 35 percent lower using BLMT technology.

Capacity	Description	Conventional Spray Booth	BLMT Unit
2,500 CFM	Capital Cost	870.00	8,000.00
	Capital Cost/ACFM	0.35	3.20
	Annual Operating Cost	22,190.00	8,255.00
	Annual Oper. Cost/ACFM	8.88	3.30
	Total Cost/ACFM (1st Year)	\$ 9.23	\$ 6.50
25,000 CFM	Capital Cost	6,550.00	80,000.00
	Capital Cost/ACFM	0.26	3.20
	Annual Operating Cost	218,890.00	66,641.00
	Annual Oper. Cost/ACFM	8.76	2.67
	Total Cost/ACFM (1st Year)	\$ 9.02	\$ 5.87

TABLE 7. Projected First-Year Total Cost/ACFM Comparison Summary for Conventional Three-Stage and BLMT Paint Overspray Filters

The economic comparison was conducted for the most reasonable conventional paint overspray collection system used to meet Aerospace NESHAP regulations for hazardous particulate matter control. The addition of HEPA filtration as a final stage is an alternative to the conventional paint booth or traditional multi-stage paint overspray collection system. Although this approach may be effective in collection of paint overspray, it is also extremely expensive. HEPA filters typically cost between \$150 and \$250, and the expense of disposal will be high due to filter bulk-volume and weight. Since this scenario would be more expensive than a more traditional multi-stage system, the HEPA alternative was not considered in the economic analysis.

The economic scenario outlined in the Appendix provides paint overspray filtration performance comparable to that required for California emissions control (for new emission sources); the scenario looks only at particle collection, *not* VOC control. A separate VOC collection and regeneration device (*e.g.*, activated carbon, bio-engineered capture bed, etc.) would be required downstream of the aerosol particle collection to meet upcoming stringent EPA VOC emission regulations under the Aerospace NESHAP.

5. RECOMMENDATIONS FOR PHASE II

Table 8 presents the recommended basic geometric and operational design criteria for a higher-capacity and more efficient BLMT prototype for the follow-on Phase II project. The bases for these criteria were developed as a result of this Phase I study, parallel efforts related to DoD/Army and DOE Phase II projects, and current regulatory requirements related to paint overspray collection.

Design Parameters	Parameter Values (for 2.5 μm filter)
No. of Disks in Disk Set	180
Disk Spaces (n)	179
Intra-Disk Spacing (d)	1.0 mm = 1.0×10^{-3} m
Disk Thickness	0.762 mm = 7.62×10^{-4} m
Disk Outside Radius (R_o)	6 inches = 0.1524 m
Disk Inside Radius (R_i)	5 inches = 0.1270 m
Particle Density (ρ_p)	2.25 g/cm ³ = 2250 kg/m ³
Density of the Gas (ρ_g)	1.1 kg/m ³
Angular Velocity (ω)	4,000 RPM (419 radians/sec)
Mass Flow Rate (\dot{M})	2,500 CFM = $1.18 \text{ m}^3/\text{sec}$
Dynamic Gas Viscosity (μ_g)	1.8×10^{-5} kg/m sec

TABLE 8. Design Parameters Required for a 2,500-ACFM BLMT Overspray Filter

Field testing of InnovaTech's Phase II prototype paint overspray collection filter is expected to be assessed under actual operating conditions at the Tyndall AFB maintenance facility.

Design modifications, enhancements, or additional research identified in this report will be addressed in Phase II. These include capacity scale-up, paint residue removal from the housing, reduced particle re-entrainment, TeflonTM coatings on disks and housing, determination of paint particle size fractional efficiencies, maximize removal efficiency and minimize pressure drop, and optimize the pressure recovery exhaust housing.

Other design modifications not explored in Phase I will be assessed in Phase II for further anticipated enhancements to the collection efficiency or reduced costs. For example, the chemistry of Air Force primers and coatings will dictate the most reasonable manner in which to collect and maintain paint overspray captured by the BLMT filter (e.g., as solid particles, sludge, or in chemical solution). InnovaTech will work with the Air Force and aerospace paint manufacturers to define the most favorable method for overspray capture and/or storage for eventual reuse or disposal.

Several potential problem areas associated with the use of the BLMT exclusion filter for sticky particle aerosol removal and collection were anticipated and addressed in the Phase I project. For instance, details relating to bearing support, lubrication, and sealing of the rotating disk set were taken into account in the Phase I project design. Sticky particle bridging or clogging in BLMT components and particle "sneakage" from the dirty side to the clean side remains a potential problem for long-term operation, and will be further addressed in the Phase II project. We anticipate a combination of sealing techniques will be required to fully address this issue. Figures 17 and 18 schematically present options for non-contact interleaving- or clearance-type seals that develop torturous paths to mitigate particle sneakage. Combining these mechanical

seals with traditional contact or brush seals (such as those used in the Phase I feasibility demonstration) will be evaluated in Phase II.

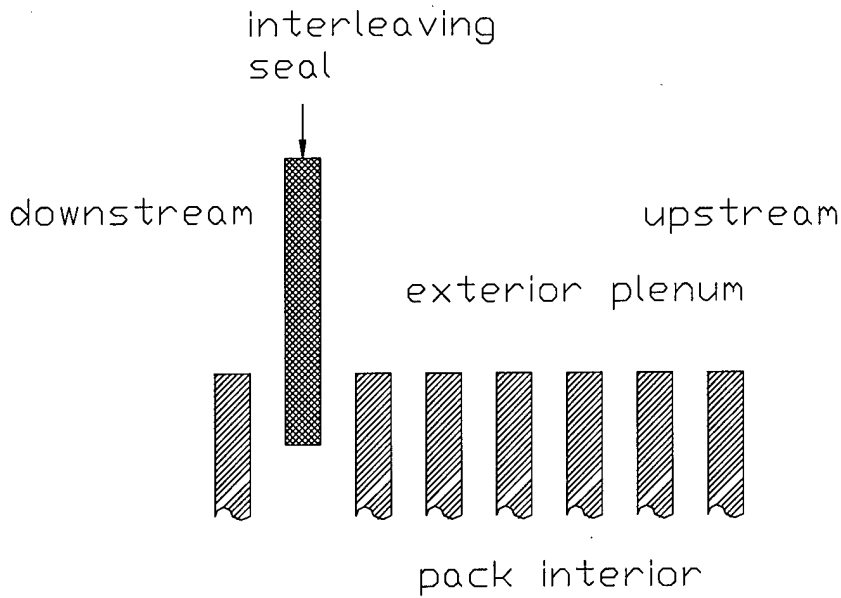

FIGURE 17. Interleaving Seal Design Modification Enhancement for Phase II Incorporation

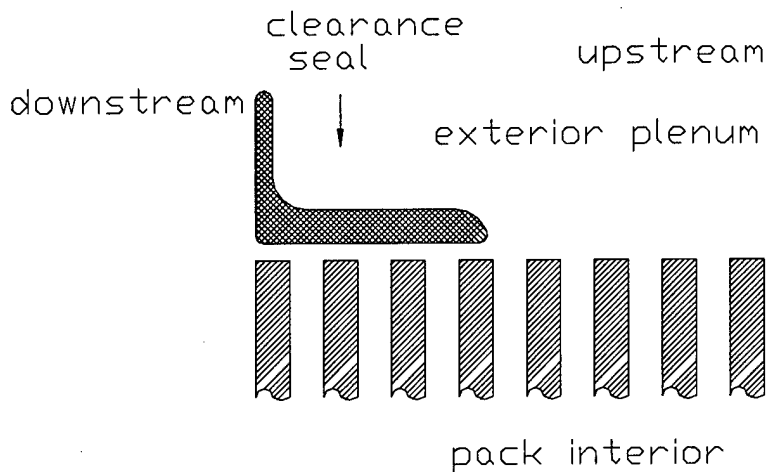

FIGURE 18. Clearance Seal Design Modification Enhancement for Phase II Incorporation

Scale-up to higher volumetric flow rates while maintaining particle collection efficiency will be achieved via two methods:

- Increasing the disk pack and housing size (with attendant issues associated with the size of the disks, *i.e.*, stability of the disk annuli at large diameters, reduced bearing rotational speed with larger radius, etc.) and

- Combining multiple standard-sized BLMT units in parallel to achieve air flow and particle collection requirements typical of DoD painting operations.

Further testing and evaluation of complementary larger-scale BLMT units in other concurrent investigations [15,16] will add to our knowledge of physical scale-up during the proposed Phase II investigation.

6. CONCLUSIONS

This Phase I feasibility study successfully demonstrated the innovative BLMT filter, which was designed to efficiently collect paint overspray and minimize related waste treatment requirements. Using the cost model developed in this report, the cost of implementing BLMT filtration technology will pay for itself in less than a year, and will continue to save on a yearly basis as the cost for used filter replacement and disposal is substantially reduced. The results of this project address specific Air Force aircraft maintenance conditions and EPA regulatory requirements, such as PM₁₀, PM_{2.5}, and the Aerospace NESHAP.

Successful completion of this project provides the basis for design, fabrication, and performance demonstration testing of a scaled-up BLMT paint overspray collection system as a follow-on Phase II project. The ultimate goal is a modular system of BLMT components capable of filtering hundreds of thousands to millions of ACFM throughput flow capacity when combined together in a parallel arrangement.

Successful completion of the proposed Phase II project will provide an appropriate design and filtration methodology for paint overspray collection system scale-up and commercialization in Phase III. This will have a profound effect on environmental compliance, significantly minimizing hazardous waste in DoD painting operations. This, in turn, will provide a beneficial economic effect on military and industrial paint spray operations. Note that this technology is adaptable to abrasive depainting operations, as well. Development of a more efficient overspray filter will substantially decrease the amount of contaminated medium (containing hazardous chromates) that will have to be disposed and concomitantly reduce the costs of operation. Employing BLMT technology would also reduce HAZMAT exposure to base personnel and outside subcontractors.

7. POTENTIAL POST APPLICATIONS

Many applications, both military and commercial, requiring efficient removal of particles from a gas stream will benefit from this new technology. Examples include abrasive depainting, mining, woodworking, foundry processes, metalworking, welding, industrial HVAC, agricultural products processing, and many others. As discussed above, self-cleaning particle air filters based on the BLMT concept have application in numerous sectors of private industry. Submicron BLMT filters could be designed to remove soot from diesel exhaust or waste incinerators to meet ever-stringent EPA air quality emission guidelines, particularly under the 1990 Clean Air Act Amendments. High-efficiency filtration of powders/dust from pharmaceutical and

semiconductor/microelectronics manufacturing processes, as well as the protection of turbine engines, are other potential applications of this technology. As previously indicated, there are numerous industries with applications amenable to BLMT filtration technology. Application examples in the military include filtration of exhaust gases associated with jet engine test cells, both painting and abrasive depainting operations, incineration and coal-fired boiler operations. Commercial applications include cleanup of gas streams in industrial, agricultural, mining, construction, power generation, and chemical industry processes.

REFERENCES

- [1] Vickers, T. W. "Selecting Your Best Route to Proper Overspray Collection," *Metal Finishing*, '97 Organic Finishing Guidebook & Directory Issue, pp. 334 – 339.
- [2] Chapman, T. E.; Mook, Jr., P. H.; and Wong, K. B. "A Comparison of Innovative Air Pollution Control Technology Demonstrations at McClellan Air Force Base," Paper # 97-MP5.04 in the *Proceedings of the Air & Waste Management Association's 90th Annual Meeting & Exhibition*, Toronto, Ontario, Canada, June 8 – 13, 1997.
- [3] Szykman, J. Data presented at the Aerospace Manufacturing and Rework Facilities NESHAP Roundtable Meeting, March 13 – 14, 1996, Durham, N.C.
- [4] Darwin, C.H. *Fractional Penetration of Paint Overspray Arrestors*, U.S. EPA, Office of Research and Development, Washington, DC, Document Number EPA-600 / R-97-011, February 1997.
- [5] Chan, T. T.; D'Arcy, J. B.; and Schreck, R. M. "High-Solids Paint Overspray Aerosols in a Spray Painting Booth: Particle Size Analysis and Scrubber Efficiency," *American Industrial Hygiene Association (AIHA) Journal*, Vol. 47, July 1986, pp. 411–418.
- [6] Hanley, J. T. "Method 319: Determination of Filtration Efficiency for Paint Overspray Arrestors," data to be presented at the Air Pollution Control Technology: Environmental Technology Verification (ETV) Program, Stakeholders Advisory Committee Meeting, Research Triangle Park, N.C., February 12–13, 1998.
- [7] Bergman, W.; Biermann, A. H.; and Sawyer, S. R. "New Test Methods for Ultra-Low Penetration Aerosol (ULPA) Filters," in *Hazards Control Department Annual Technology Review 1985*. Livermore, California: Lawrence Livermore National Laboratory, 1986, pp. 43–47.
- [8] Payet, S.; Boulard, D.; Madelaine, G.; and Renoux, A. "Penetration and Pressure Drop of a HEPA Filter During Loading with Submicron Liquid Particles," *Journal of Aerosol Science*, Vol. 23, 1992, pp. 723–735.
- [9] Mohrmann, H. "Loading of Fiber Filters with Aerosols Consisting of Liquid Particles," *Staub - Reinhaltung Luft*, Vol. 30, No. 8, 1970, pp. 1–6.

- [10] Mohrmann, H., and Marchlewitz, W. "Loading of Fiber Filters with Aerosols," *Staub – Reinhaltung Luft*, Vol. 34, No. 3, 1974, pp. 91–93.
- [11] Leith, D.; Raynor, P. C.; Boundy, M. G.; and Cooper, S. J. "Performance of Industrial Equipment to Collect Coolant Mist," *American Industrial Hygiene Association (AIHA) Journal*, Vol. 57, Dec. 1996, pp. 1142–1148.
- [12] Wright, S. R., and Shaughnessy, E. J., *Novel Inlet Protection System for Auxiliary Power Units Using Boundary-Layer Momentum Transfer for Fine Particle Separation*, DoD SBIR Phase I Final Report # AATD-94-1, Contract Number DAAJ02-93-C-0015, May 31, 1994.
- [13] Wright, S. R. *Airborne Toxic Particulate Emission Control Via a Boundary Layer Momentum Transfer Exclusion Filter*, EPA SBIR Phase I Final Report # EPA-96-1, Contract Number 68D50106, March 6, 1996.
- [14] Wright, S. R. *Advanced Nuclear Air Precleaner*, DOE SBIR Phase I Final Report, Grant Number DE-FG02-95ER82026, March 23, 1996.
- [15] Wright, S. R. *Novel Inlet Protection System for Auxiliary Power Units*, DoD SBIR Phase II Proposal, Army contract Number DAAJ02-95-C-0009, March 23, 1995.
- [16] Wright, S. R. *Advanced Nuclear Air Precleaner*, DOE SBIR Phase II Proposal, Grant Number DE-FG02-95ER82026, January 29, 1996.
- [17] Bond, J. H.; Shaughnessy, E. J., Jr.; and Wright, S. R. "Boundary Layer Momentum Transfer (BLMT) Theory as it Relates to Dynamic Particle Separation," *Advances in Filtration and Separation Technology—Technology Wins*, Vol. 9, Valley Forge, Pa., April 21–24, 1996, pp. 83–88.
- [18] Wright, S. R.; Bond, J. A.; Crouch, H. S.; Knight, D. A.; and Shaughnessy, E. J., Jr.; "Self-Cleaning, High-Efficiency Dynamic Particle Exclusion Filter," *Advances in Filtration and Separation Technology —Technology Wins*, Vol. 9, Valley Forge, Pa., April 21–24, 1996, pp. 68–73.
- [19] Stolle, M. "Filtration Efficiency Study: ATI Aerospace 3000 Filter System," Figures 1 and 2, Air Technologies, Inc., Ottawa, Kansas, April 17, 1997, pp. 6–7.
- [20] Stolle, M. "Filtration Technology for the Control of Solid Hazardous Air Pollutants in Paint Booth Operations," Paper # 97-TP160.05 in the *Proceedings of the Air & Waste Management Association's 90th Annual Meeting & Exhibition*, Toronto, Ontario, Canada, June 8–13, 1997.
- [21] Kwok, K. C. "Fractional Efficiency and Loading Tests for Paint Filters," *Fluid/Particle Separation Journal*, Vol. 10, No. 3, December 1997, pp. 255–264.

APPENDIX A

Economic Analysis of Filter Usage in Spray Booths

Cases 1 through 4 represent conventional, three-stage spray booth scenarios, two at 2,500 cfm (150 and 100 feet per minute face velocity cases), plus two at 25,000 cfm (with similar face velocities). The next two cases present BLMT spray booth scenarios, one at 2,500 cfm and the other at 25,000 cfm. Both of these cases assume 520 feet per minute face velocities, which was demonstrated in our Phase I tests.

In conventional systems, to maintain a face velocity of 100 feet per minute, the 2,500-cfm system requires 9 filters in parallel. A face velocity of 150 feet per minute requires 6 filters in parallel. Similarly for the 25,000-cfm system, the 100- and 150-foot per minute systems require 90 and 60 filters in parallel, respectively.

Representatives of a commercial paint spray booth manufacturer provided initial capital cost and performance data for conventional, three-stage spray booths. Costs for power consumption are based on \$0.07 per kilowatt-hour, and power consumption for BLMT was assumed to be a five-fold increase over that for the conventional unit.

Data for various filters in the conventional system include:

- 1st stage - low efficiency, weighs ½ pound, replaced after accumulating 8 pounds of loading, cost \$5.00 each.
- 2nd stage - medium efficiency, weighs 1-1/2 pounds, replaced each week, cost \$27 each.
- 3rd stage - 95 percent ASHRAE filter, high-efficiency, weighs 2-3/4 pounds, replaced each month, cost \$68 each.

Data for BLMT collection (sponge) pad is based on information supplied by a commercial filter media manufacturer. The collection pad material costs \$0.51 per square foot and weighs 0.25 pounds per square foot. The collection pads are expected to hold 10 pounds of paint solids per square foot. A 2,500-cfm unit requires 4.4 square feet of pad material to cover the inside of the scroll housing. The 25,000-cfm unit is assumed to require approximately 20 square feet of pad material.

A disposal cost for paint solid residue of \$1.05 per pound is used based on data obtained from a Ft. Bragg study [A1]. This value is common to both conventional and BLMT systems.

Appendix Reference

[A1] "Minimizing Hazardous Waste," *Pollution Engineering*, June 1996, pp. 68-70.

Assumptions for Spray Booth Case 1:

2,500	cfm capacity
150	fpm flow (filter face velocity)
1	pound of paint overspray per hour of operation per 1,000 cfm, or 0.001 lb/hr/cfm
6	filter "bays" per unit
8	pounds of paint held per filter
1,920	hours of booth operation per year

1st stage filters:

Booth capacity between filter replacements:

6 filters x 8 lb/filter = 48 pounds of paint

Amount of time to reach capacity:

48 pounds/(2,500 cfm x 0.001 lb/hr/cfm) = 19.2 hours

Number of filter changes required:

1920 hrs/year/19.2 hrs/filter set = 100 sets/year

Total number of filters required per year (1st stage)

100 sets/year x 6 filters/set = **600 filters/year**

2nd stage filters:

6 filters x 48 weeks = **288 filters/year**

3rd stage filters:

6 filters x 12 months = **72 filters/year**

Assumptions for Spray Booth Case 2:

2,500	cfm capacity
100	fpm flow (filter face velocity)
1	pound of paint overspray per hour of operation per 1,000 cfm, or 0.001 lb/hr/cfm
9	filter "bays" per unit
8	pounds of paint held per filter
1,920	hours of booth operation per year

1st stage filters:

Booth capacity between filter replacements:

$$9 \text{ filters} \times 8 \text{ lb/filter} = 72 \text{ pounds of paint}$$

Amount of time to reach capacity:

$$72 \text{ pounds} / (2,500 \text{ cfm} \times 0.001 \text{ lb/hr/cfm}) = 28.8 \text{ hours}$$

Number of filter changes required:

$$1920 \text{ hrs/year} / 28.8 \text{ hrs/filter set} = 66.7 \text{ sets/year}$$

Total number of filters required per year (1st stage)

$$66.7 \text{ sets/year} \times 9 \text{ filters/set} = \mathbf{600 \text{ filters/year}}$$

2nd stage filters:

$$9 \text{ filters} \times 48 \text{ weeks} = \mathbf{432 \text{ filters/year}}$$

3rd stage filters:

$$9 \text{ filters} \times 12 \text{ months} = \mathbf{108 \text{ filters/year}}$$

Assumptions for Spray Booth Case 3:

25,000	cfm capacity
150	fpm flow (filter face velocity)
1	pound of paint overspray per hour of operation per 1,000 cfm, or 0.001 lb/hr/cfm
60	filter "bays" per unit
8	pounds of paint held per filter
1,920	hours of booth operation per year

1st stage filters:

Booth capacity between filter replacements:
 $60 \text{ filters} \times 8 \text{ lb/filter} = 480 \text{ pounds of paint}$

Amount of time to reach capacity:
 $480 \text{ pounds} / (25,000 \text{ cfm} \times 0.001 \text{ lb/hr/cfm}) = 19.2 \text{ hours}$

Number of filter changes required:
 $1920 \text{ hrs/year} / 19.2 \text{ hrs/filter set} = 100 \text{ sets/year}$

Total number of filters required per year (1st stage)
 $100 \text{ sets/year} \times 60 \text{ filters/set} = 6,000 \text{ filters/year}$

2nd stage filters:

$60 \text{ filters} \times 48 \text{ weeks} = 2,880 \text{ filters/year}$

3rd stage filters:

$60 \text{ filters} \times 12 \text{ months} = 720 \text{ filters/year}$

Assumptions for Spray Booth Case 4:

25,000	cfm capacity
100	fpm flow (filter face velocity)
1	pound of paint overspray per hour of operation per 1,000 cfm, or 0.001 lb/hr/cfm
90	filter "bays" per unit
8	pounds of paint held per filter
1,920	hours of booth operation per year

1st stage filters:

Booth capacity between filter replacements:
 $90 \text{ filters} \times 8 \text{ lb/filter} = 720 \text{ pounds of paint}$

Amount of time to reach capacity:
 $720 \text{ pounds} / (25,000 \text{ cfm} \times 0.001 \text{ lb/hr/cfm}) = 28.8 \text{ hours}$

Number of filter changes required:
 $1920 \text{ hrs/year} / 28.8 \text{ hrs/filter set} = 66.7 \text{ sets/year}$

Total number of filters required per year (1st stage)
 $66.7 \text{ sets/year} \times 90 \text{ filters/set} = 6,000 \text{ filters/year}$

2nd stage filters:

$90 \text{ filters} \times 48 \text{ weeks} = 4,320 \text{ filters/year}$

3rd stage filters:

$90 \text{ filters} \times 12 \text{ months} = 1,080 \text{ filters/year}$

Assumptions for BLMT Case 1:

2,500	cfm
10	pounds of paint held per square foot of "sponge"
4.4	square feet of "sponge" needed per unit
1	pound of paint overspray per hour of operation per 1,000 cfm, or 0.001 lb/hr/cfm
1920	hours of booth operation per year

Sponge capacity between replacements:

$$10 \text{ lb/sq. ft.} \times 4.4 \text{ sq. ft.} \times 2,500 \text{ cfm} \times 0.001 \text{ lb/hr/cfm} \\ = 17.6 \text{ hrs (use 16 hours or change out every other day)} = 16 \text{ hrs}$$

Amount of sponge required per year:

$$1920 \text{ hrs/yr} / 16 \text{ hrs/sponge set} = 120 \text{ sponge sets}$$

$$120 \text{ sets} \times 4.4 \text{ sq. ft./set} = 528 \text{ sq. ft.}$$

Assumptions for BLMT Case 2:

25,000	cfm
10	pounds of paint held per square foot of "sponge"
20	square feet of "sponge" needed per unit
1	pound of paint overspray per hour of operation per 1,000 cfm, or 0.001 lb/hr/cfm
1920	hours of booth operation per year

Sponge capacity between replacements:

$$10 \text{ lb/sq. ft.} \times 20 \text{ sq. ft.} \times 25,000 \text{ cfm} \times 0.001 \text{ lb/hr/cfm} = 8 \text{ hrs}$$

Amount of sponge required per year:

$$1920 \text{ hrs/yr} / 8 \text{ hrs/sponge set} = 240 \text{ sponge sets}$$

$$240 \text{ sets} \times 20 \text{ sq. ft./set} = 4,800 \text{ sq. ft.}$$

Annual Cost Summary for Spray Booth Case 1:

Power cost:

motor size	cost rate		total cost
5 HP	x \$100.26 /HP/year	=	\$501.30

Filter purchase cost:

1st stage:	filter cost		total cost
600 filters	x \$5.00 /filter	=	\$3,000.00

2nd stage:			
288 filters	x \$27.00 /filter	=	\$7,776.00

3rd stage:			
72 filters	x \$68.00 /filter	=	\$4,896.00

Filter disposal cost:

1st stage:	weight per filter	disposal cost	total cost
600 filters	x 0.5 lbm/filter	x \$1.05 /pound	= \$315.00

2nd stage:			
288 filters	x 1.5 lbm/filter	x \$1.05 /pound	= \$453.60

3rd stage filter:			
72 filters	x 2.75 lbm/filter	x \$1.05 /pound	= \$207.90

Waste disposal cost:

number of filters	capture per filter	disposal cost	total cost
600 filters	x 8 lbm/filter	x \$1.05 /pound	= \$5,040.00

Total cost: \$22,190

Capital Cost:	\$ 870.00
Capital Cost per CFM:	\$ 0.35
Yearly Maintenance Cost:	\$22,190.00
Yearly Maintenance Cost per CFM:	\$ 8.88

Annual Cost Summary for Spray Booth Case 2:

Power cost:

motor size			cost rate		total cost
5	HP	x	\$100.26 /HP/year =		\$501.30

Filter purchase cost:

1st stage filter:			filter cost		total cost
600	filters	x	\$5.00 /filter =		\$3,000.00

2nd stage filter:			filter cost		total cost
432	filters	x	\$27.00 /filter =		\$11,664.00

3rd stage filter:			filter cost		total cost
108	filters	x	\$68.00 /filter =		\$7,344.00

Filter disposal cost:

1st stage:		weight per filter		disposal cost		total cost
600	filters	x	0.5 lbm/filter	x	\$1.05/pound =	\$315.00

2nd stage:		weight per filter		disposal cost		total cost
432	filters	x	1.5 lbm/filter	x	\$1.05 /pound =	\$680.40

3rd stage:		weight per filter		disposal cost		total cost
108	filters	x	2.75 lbm/filter	x	\$1.05 /pound =	\$311.85

Waste disposal cost:

number of filters		capture per filter		disposal cost		total cost
600	filters	x	8 lbm/filter	x	\$1.05 /pound =	\$5,040.00

Total cost: \$28,856.55

Capital Cost:	\$ 870.00
Capital Cost per CFM:	\$ 0.35
Yearly Maintenance Cost:	\$28,856.55
Yearly Maintenance Cost per CFM:	\$ 11.54

Annual Cost Summary for Spray Booth Case 3:

Power cost:

motor size	cost rate	total cost
20 HP x	\$100.26 /HP/year =	\$2,005.20

Filter purchase cost:

1st stage:	filter cost	total cost
6,000 filters x	\$5.00 /filter =	\$30,000.00

2nd stage:		
2,880 filters x	\$27.00 /filter =	\$77,760.00

3rd stage:		
720 filters x	\$68.00 /filter =	\$48,960.00

Filter disposal cost:

1st stage:	weight per filter	disposal cost	total cost
6,000 filters x	0.5 lbm/filter x	\$1.05 /pound =	\$3,150.00

2nd stage:			
2,880 filters x	1.5 lbm/filter x	\$1.05 /pound =	\$4,536.00

3rd stage:			
720 filters x	2.75 lbm/filter x	\$1.05 /pound =	\$2,079.00

Waste disposal cost:

number of filters	capture per filter	disposal cost	total cost
6,000 filters x	8 lbm/filter x	\$1.05 /pound =	\$50,400.00

Total cost: \$218,890.20

Capital Cost:	\$ 6,550.00
Capital Cost per CFM:	\$ 0.26
Yearly Maintenance Cost:	\$218,890.20
Yearly Maintenance Cost per CFM:	\$ 8.76

Annual Cost Summary for Spray Booth Case 4:

Power cost:

motor size	cost rate	total cost
20 HP x	\$100.26 /HP/year =	\$2,005.20

Filter purchase cost:

1st stage:	filter cost	total cost
6,000 filters x	\$5.00/filter =	\$30,000.00

2nd stage:		
4,320 filters x	\$27.00/filter =	\$116,640.00

3rd stage:		
1,080 filters x	\$68.00/filter =	\$73,440.00

Filter disposal cost:

1st stage:	weight per filter	disposal cost	total cost
6,000 filters x	0.5 lbm/filter x	\$1.05/pound =	\$3,150.00

2nd stage:			
4,320 filters x	1.5 lbm/filter x	\$1.05/pound =	\$6,804.00

3rd stage:			
1,080 filters x	2.75 lbm/filter x	\$1.05/pound =	\$3,118.50

Waste disposal cost:

number of filters	capture per filter	disposal cost	total cost
6,000 filters x	8 lbm/filter x	\$1.05/pound =	\$50,400.00

Total cost: \$285,557.70

Capital Cost:	\$ 6,550.00
Capital Cost per CFM:	\$ 0.26
Yearly Maintenance Cost:	\$285,557.70
Yearly Maintenance Cost per CFM:	\$ 11.42

Annual Cost Summary for BLMT Case 1:

BLMT power :

motor size	cost rate	total cost
3 HP x	\$100.26/HP/year =	\$300.78

Downstream blower power:

motor size	cost rate	total cost
25 HP x	\$100.26/HP/year =	\$2,506.50

Sponge Cost:

sponge area	cost rate	total cost
528 sq. ft. x	\$0.51/sq. ft =	\$269.28

Sponge Disposal Cost:

sponge area	cost rate	disposal cost	total cost
528 sq. ft. x	0.25 lb/sq. ft. x	\$1.05 /pound =	\$138.60

Waste Disposal Cost :

2,500 cfm x 0.001 lb/hr/cfm x 1,920 hrs/year x \$1.05 pound = \$5,040.00

Total Cost: \$8,255.16

Capital Cost:	\$8,000.00
Capital Cost per CFM:	\$ 3.20
Yearly Maintenance Cost:	\$8,255.16
Yearly Maintenance Cost per CFM:	\$ 3.30

Annual Cost Summary for BLMT Case 2:

Power cost:

BLMT motor size	cost rate		total cost
25 HP x	\$100.26 /HP/year	=	\$2,506.50
Downstream blower	cost rate		total cost
100 HP x	\$100.26 /HP/year	=	\$10,026.00

Sponge Cost:

sponge area	cost rate		total cost
4,800 sq. ft. x	\$0.51/sq. ft	=	\$2,448.00

Sponge Disposal Cost:

sponge area	cost rate	disposal cost	total cost
528 sq. ft. x	0.25 lb/sq. ft. x	\$1.05/pound	= \$138.60

Waste Disposal Cost :

$$2,500 \text{ cfm} \times 0.001 \text{ lb/hr/cfm} \times 1,920 \text{ hrs/year} \times \$1.05 \text{ pound} = \$50,400.00$$

Total Cost: \$66,640.50

Capital Cost:	\$80,000.00
Capital Cost per CFM:	\$ 3.20
Yearly Maintenance Cost:	\$66,640.50
Yearly Maintenance Cost per CFM:	\$ 2.67

APPENDIX B

Data to Support Figure 16: Pressure Recovery Using a BLMT Exit Scroll

Without Pressure Recovery Scroll			With Pressure Recovery Scroll		
Velocity Pressure (inches w.g.)	Volumetric Flow Rate (scfm)	Static Pressure (inches w.g.)	Velocity Pressure (inches w.g.)	Volumetric Flow Rate (scfm)	Static Pressure (inches w.g.)
0.02	605.48	1.50	0.05	957	1.50
0.08	1210.96	5.25	0.11	1420	3.00
0.12	1483.12	8.00	0.16	1713	5.00
0.15	1658.18	10.00	0.2	1915	6.00
0.18	1816.45	12.00	0.24	2097	7.50
0.19	1866.22	14.50	0.25	2141	9.00
			0.3	2345	11.00
			0.33	2459	12.00
			0.36	2569	12.75
			0.37	2604	12.50
			0.38	2639	13.50
			0.38	2639	13.25