

ARMY RESEARCH LABORATORY

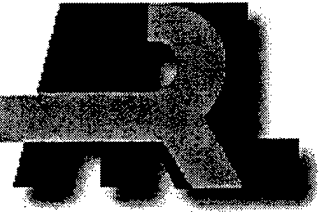

Design and Analysis of a Fuze-Configurable Range Correction Device for an Artillery Projectile

Michael S.L. Hollis
Fred J. Brandon

ARL-TR-2074

DECEMBER 1999

20000111 108

Macor[®] is a registered trademark of Dow-Corning.

The findings in this report are not to be construed as an official Department of the Army position unless so designated by other authorized documents.

Citation of manufacturer's or trade names does not constitute an official endorsement or approval of the use thereof.

Destroy this report when it is no longer needed. Do not return it to the originator.

Army Research Laboratory

Aberdeen Proving Ground, MD 21005-5066

ARL-TR-2074

December 1999

Design and Analysis of a Fuze-Configurable Range Correction Device for an Artillery Projectile

Michael S.L. Hollis
Fred J. Brandon
Weapons and Materials Research Directorate

DTIC QUALITY INSPECTED

Approved for public release; distribution is unlimited.

Abstract

The primary purpose of the low cost competent munitions (LCCM) program was to improve the effectiveness of indirect fire support from cannon artillery (D'Amico 1996). With the advances in microelectronics, sensor technology, and packaging design, the reality of a range correction device for artillery is conceivable. One of the main objectives of the range correction device concept was to contain all the mechanical and electrical components within a fuze-like envelope, while maintaining certain constraints that would allow the fuze to fit into a variety of artillery shells used by North Atlantic Treaty Organization (NATO) countries. Another objective of the range correction device concept was to avoid any changes within the ogive of any of the projectiles in the existing stockpile.

This report is a culmination of many design iterations, numerical analyses, shock tests, and actual cannon launchings. Most of the design iterations and numerical analyses are not mentioned in this report simply because they were stepping stones that led to the final design. Structural analyses indicated that the overall prototype design was durable enough to withstand the most severe artillery cannon launching available today. The design should be capable of withstanding a 15,000 g inertial set-back load with 150,000 rad/s² of angular acceleration. In addition, the design should be capable of deploying while the projectile has velocity of 650 m/s and is spinning at 250 cycles per second. The next step would be to fabricate and test the design in order to truly verify the integrity of the structure and to determine the overall effect of the deployed drag blades on the range of flight.

ACKNOWLEDGMENTS

The authors would like to thank the following people for their help and expertise. Mrs. Lisa (Jara) Paolucci is acknowledged for her mathematical talents. Messrs. Eugene Ferguson and David Vasquez are commended for the actual field testing and data reduction of the 80-mm D-ring dragster prototype, which was fired at the National Aeronautics and Space Administration Wallops Island facility. Messrs. Ferguson and Craig Myers are also to be commended for their novel electronic packaging design and fabrication for the flight test. In addition, the authors would like to thank Mr. David Hepner for his continual use of the windshield product which further validates the design. Also, Messrs. George Eckstein and Fred Oliver are thanked for providing parts and drawings of the multi-option fuze artillery (MOFA).

INTENTIONALLY LEFT BLANK

TABLE OF CONTENTS

	<u>Page</u>
LIST OF FIGURES	vii
LIST OF TABLES	ix
1. INTRODUCTION	1
2. DESIGN CRITERIA	3
3. DRAG BLADE DESIGN	4
4. ANALYSIS OF THE DRAG BLADES	6
5. ANALYSIS OF THE HEXAGONAL SPLINE	7
6. BOUNDARY CONDITIONS FOR THE HEXAGONAL SPLINE ANALYSIS .	7
7. RESULTS	8
8. DESIGN OF THE DRAG BLADE RELEASE DEVICE	11
9. DESIGN AND ANALYSIS OF THE WINDSHIELD	12
10. BOUNDARY CONDITIONS OF THE WINSHIELD FINITE ELEMENT ANALYSIS	14
11. RESULTS	14
12. TESTING OF THE WINDSHIELD	16
13. CONCLUSION	16
REFERENCES	19
APPENDICES	
A. Schematics for Range Correction Concept With Variable Deployment D-rings	21
B. Photographs of Flight Test Hardware	41
DISTRIBUTION LIST	55
REPORT DOCUMENTATION PAGE	59

INTENTIONALLY LEFT BLANK

LIST OF FIGURES

<u>Figure</u>		<u>Page</u>
1.	Range Correction Concept With the D-rings Deployed to 80 mm	2
2.	Range Correction Concept With the D-rings Deployed to 100 mm	2
3.	Electro-Mechanical Assembly of the Range Corrector, Gun-Launched Prototype .	3
4.	The Prototype Assembly for the Drag Blades and Guides	5
5.	Lowermost Blade Guide and the Uppermost Blade Guide	5
6.	A Lowermost Drag Blade and an Uppermost Drag Blade	6
7.	Simplified Geometries of the Lowermost and Uppermost Blade Guides	8
8.	The Finite Element Model of the Assembled Lowermost and Uppermost Blade Guides	8
9.	Von Mises Stress Contour Plot of the Hexagonal Spline	10
10.	Von Mises Stress Contour Plot of the Uppermost Guide Plate	10
11.	Exploded View of the Drag Blade Release Device	11
12.	An Isometric View of a Crank Arm From the Drag Blade Release Device Assembly	12
13.	Schematic of the Nylon Windshield	13
14.	Schematic of the Ceramic Nose Tip	14
15.	Boundary Conditions and Restraints of the Windshield Model	15
16.	Finite Element Model of the Windshield	15
17.	Axial Stress Contour Plot of the Windshield Model	16
18.	The M773 MOFA and a Possible Incorporation of the Range Corrector Device . .	17

INTENTIONALLY LEFT BLANK

LIST OF TABLES

<u>Table</u>		<u>Page</u>
1.	4
2.	Material Properties Used for the Finite Element Analysis	9
3.	Material Properties of Surveyed Plastics	13

INTENTIONALLY LEFT BLANK

DESIGN AND ANALYSIS OF A FUZE-CONFIGURABLE TRAJECTORY CORRECTION DEVICE FOR AN ARTILLERY PROJECTILE

1. INTRODUCTION

The primary purpose of the low cost competent munitions (LCCM) program was to improve the effectiveness of indirect fire support from cannon artillery (D'Amico 1996). With the advances in microelectronics, sensor technology, and packaging design, the reality of a range correction device is conceivable. A previous report entitled "Preliminary Design of a Range Correction Module for an Artillery Shell" (Hollis 1996) demonstrated a possible concept called the D-ring range correction device. One of the main objectives of the range correction device concept was to contain all the mechanical and electrical components within a fuze-like envelope, while maintaining certain constraints that would allow the fuze to fit into a variety of artillery shells used by North Atlantic Treaty Organization (NATO) countries. Another objective of the range correction device concept was to avoid any changes within the ogive of any of the projectiles in the existing stockpile.

Range correction is achieved by a mechanism that symmetrically deploys four D-shaped blades, or drag blades, with the sole purpose of increasing drag. Estimates have been made of the percent change in drag as related to increases in frontal area. Before deployment of the drag blades, the frontal area of the fuze would be the largest diameter of the fuze geometry, which is approximately 60.7 mm. When deployed, the frontal area will resemble figure (a) in Figure 1. The deployed D-rings, with a spread of 80 mm, will increase the frontal area by 1.63 times. In an effort to improve the range correction concept, the D-rings are extended a centimeter farther to a deployment diameter of 100 mm, as seen in Figure 2. The increase in frontal area is 2.39 times. An initial study by Brandon and Jara has indicated that reasonable maneuver authorities can be achieved for frontal areas of 7.3 in² (47.1 cm²) and 10.7 in² (69.0 cm²), which corresponds, respectively, to the 80-mm and 100-mm deployment diameters.

This report describes the final design for a prototype gun-launched range correction device for an artillery shell. The design considered the future of artillery launching platforms, such as Crusader, and incorporated the possible launch and flight conditions. The windshield, or radome, was designed to withstand artillery cannon launching and aerodynamic heating from a Mach 3 flight. The mechanisms involved in the deployment of the D-rings are designed to take the abusive launch, flight conditions, and deployment phases of cannon-launched artillery projectiles. In addition, the design also allowed flexibility in deployment diameters of the blades. Depending on the desired deployment diameter, 80 mm or 100 mm, one could assemble the device with

different blades. The 80-mm deployment diameter version would require blade stops and would deploy the blades to the 80-mm diameter, whereas the 100-mm deployment diameter version would simply require a different stop. The stops would be located only on the blades so that no further modifications of the rest of the drag device would be necessary. This report discusses the final design and the structural analyses involved. Figure 3 displays the gun launch configuration of the prototype.

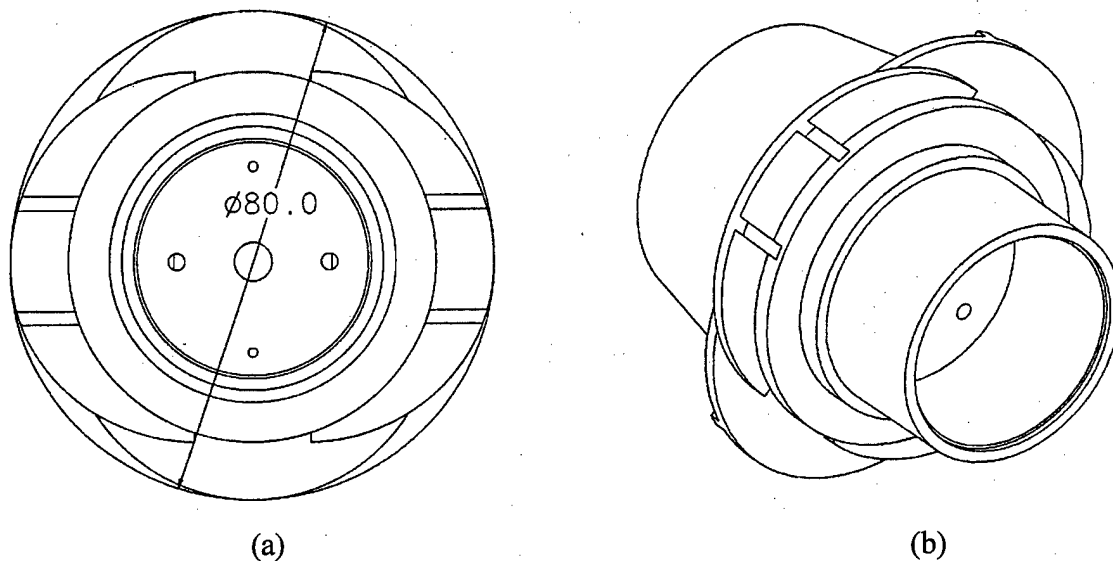

Figure 1. Range Correction Concept With the D-Rings Deployed to 80 mm.

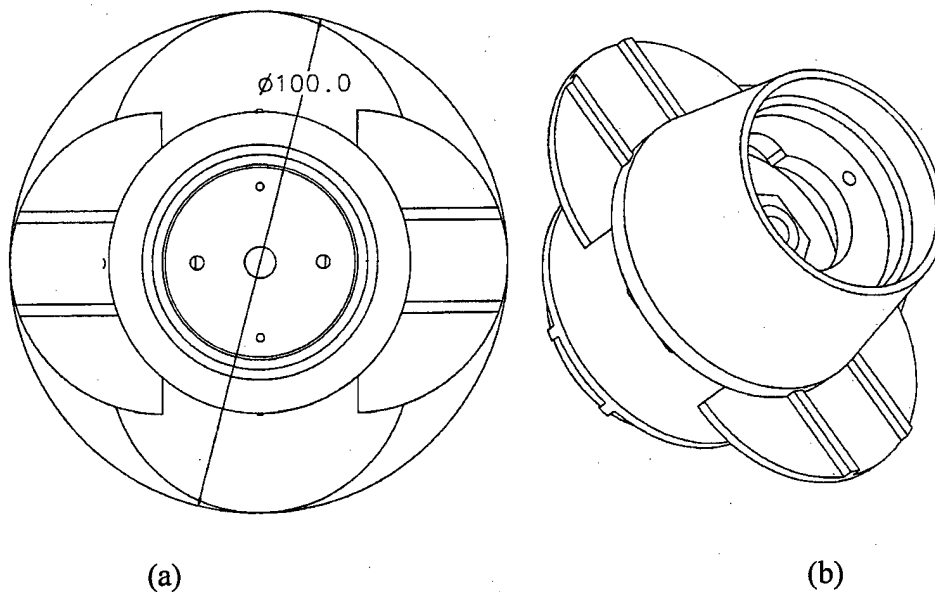

Figure 2. Range Correction Concept With the D-rings Deployed to 100 mm.

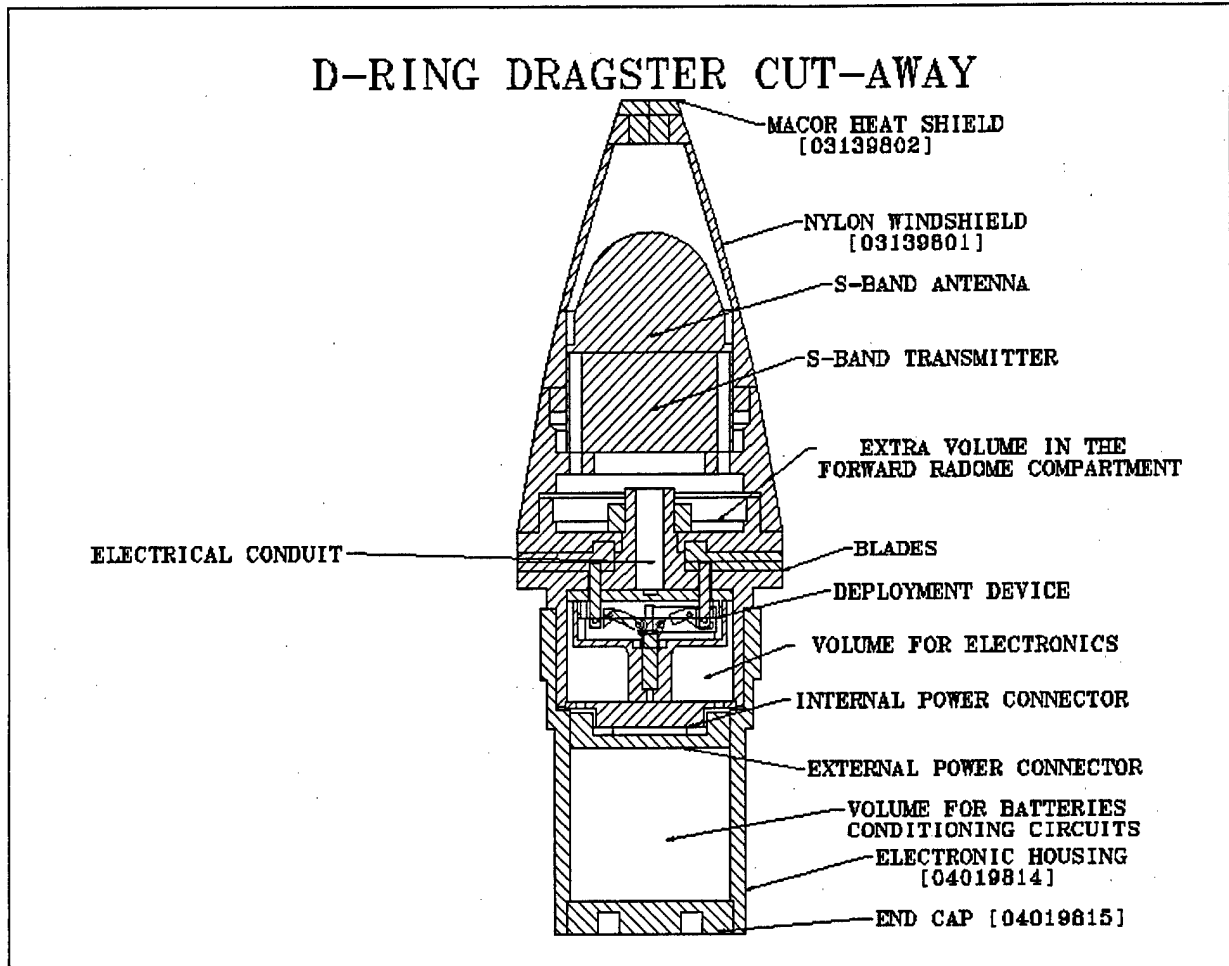

Figure 3. Electro-Mechanical Assembly of the Range Corrector, Gun-Launched Prototype.

2. DESIGN CRITERIA

The three main criteria for the prototype are structural integrity during launch and flight, size, and room for supporting electronics. The cannon-launching environment would produce the conditions shown in Table 1.

The criterion for room is to keep the extension of the device to a minimum. When the projectile is fitted with the device, the assembly should be no longer than 1 meter long. The device also cannot protrude too far into the ogive so that it interferes with existing hardware in the projectile. However, this being a prototype, the latter criterion is relaxed to allow for relatively large, off-the-shelf electronics that would support the prototype device. Figure 3 displays the amount of available volume for supporting electronics. The maximum volume totals 8.7 in³.

Table 1. Conditions of the Cannon-Launching Environment

Condition	Quantity
muzzle velocity	<u>825</u> m/s
muzzle exit spin rate	300 Hz (1885 rad/s)
inertial set-back load	15,000 g's
maximum angular acceleration	150,000 rad/s ²

3. DRAG BLADE DESIGN

“Show me your successes; don’t show me your failures” (anonymous 1997). The prototype assembly for the drag blades and the guides is depicted in Figure 4. It is the intent of this design, for the uppermost blade guide bulkhead and the drag blades to stack on top of the lowermost blade guide bulkhead. The hex thin nut would then thread onto the circular boss on the lowermost guide thus locking the assembly together. The blades can slide outward along the grooves provided in the uppermost and lowermost guides. The uppermost and lowermost guides are depicted in Figure 5a and b, respectively. During the pre-deployment part of flight, the lowermost blades would be locked in place by two pins (not shown). The pins would protrude through holes in the lowermost guide and into holes in the lowermost blades. Figure 6a depicts a lowermost blade, while Figure 6b shows an uppermost blade. Notice that on the uppermost blade is a small wedge-shaped projection that fits into a notched region on the lowermost blade, as seen in Figure 6a. When the blades are assembled, and a high spin rate is applied, centrifugal forces are pulling the blades outward. The uppermost blades are restrained because the wedge projection on each blade is trying to force the lowermost blades apart. However, the lowermost blades are locked in place by pins. Therefore, with the pins in place, the blades are locked into position for gun launch and free flight.

Several design iterations were necessary to develop a viable solution for the drag blade design. Early concepts incorporated extra parts such as a cam plate and guide pins as a means of restraining and synchronizing the ejection of the blades. However, with the possibility of faster muzzle velocities and more abusive boundary conditions, these parts required further structural scrutiny. Quasi-static, finite element analyses revealed weaknesses in the design of the cam plate and the guide pins. Similar analyses that were performed on the current design indicated significantly improved performance during the launch and free flight conditions.

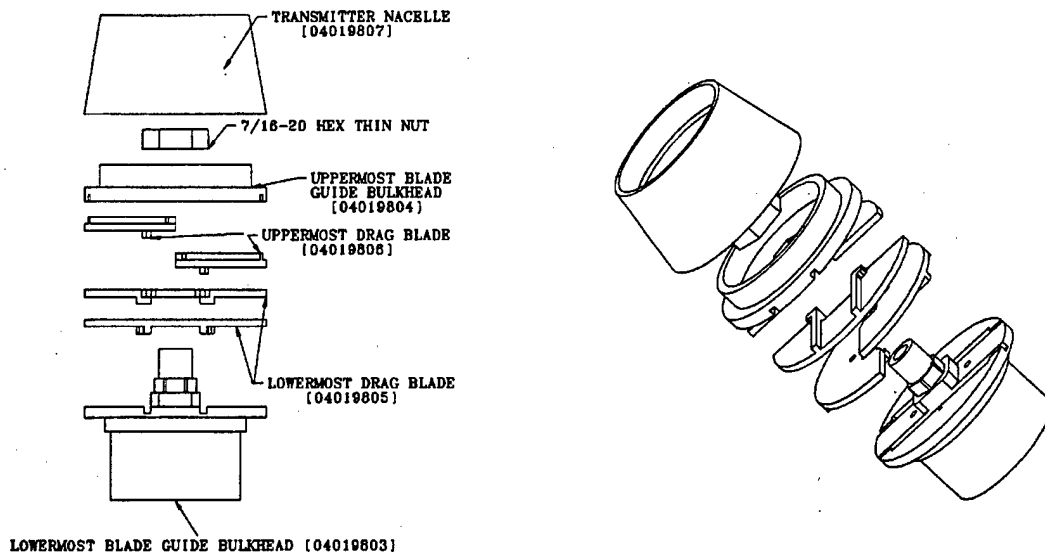

Figure 4. The Prototype Assembly for the Drag Blades and Guides.

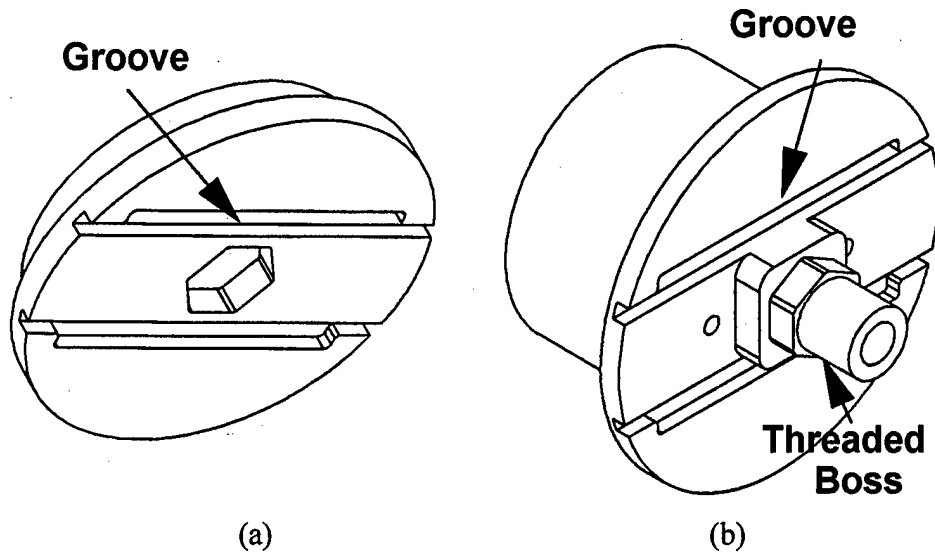

Figure 5. Uppermost Blade Guide and the Lowermost Blade Guide.

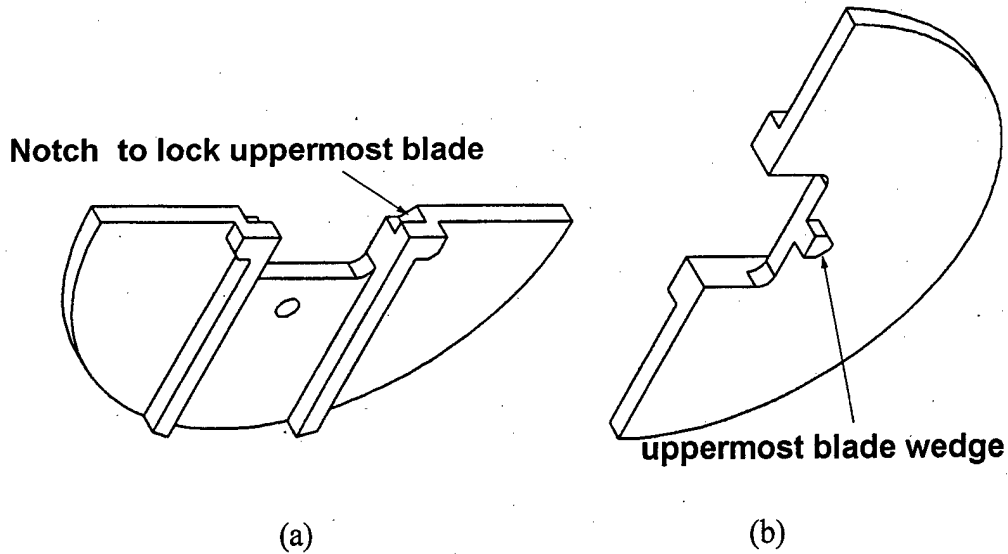

Figure 6. A Lowermost Drag Blade and an Uppermost Drag Blade.

The design for the uppermost and lowermost guides, as seen in Figure 5, required a few iterations and structural analyses. In order for the device to survive the torque loading of gun launch and also integrate the relatively large drag blades, a hexagonal spline was required. The hexagonal spline on the lowermost guide, coupled with a hexagonal hole in the uppermost guide, allowed enough surface area to effectively transmit the torque produced by the $150,000 \text{ rad/s}^2$ angular acceleration. This angular acceleration, combined with the predicted moment of inertia of the upper portion of the drag device, 0.79 lb-in^2 ($2.3 \times 10^{-4} \text{ kg-m}^2$), produces a torque of 307.5 lb-in. (34.7 N-m). As a result of a quasi-static finite element analysis (FEA), the lowermost guide was required to be made of steel with a minimum yield strength of $150,000 \text{ psi}$, and the uppermost guide is to be made of aluminum 7075-T651 that has a yield strength of $73,000 \text{ psi}$ (503 MPa). The FEA is discussed in detail later in the report.

4. ANALYSIS OF THE DRAG BLADES

Several analyses were performed on the blades in an effort to determine the effects of various loading conditions. A possible worst case deployment scenario occurs when the projectile has a velocity of 650 m/s and a spin rate of 250 Hz . The details of this analysis are presented in Hollis (1998). This report documents an earlier design of the blades that are locked in place by guide pins that connect the blades to a central cam plate. The results of Hollis (1998) indicated that the blades, deployed to 100 mm in diameter, with the 250-Hz spin rate and an

aerodynamic load applied, would remain structurally intact. However, analysis of the same blades during the pre-deployment conditions of 300 Hz showed structural problems. The analysis indicated that the guide pins were bending and the drag blade and the cam plate were possibly plastically deforming. The final blade design, as seen in Figure 6, were the most successful in handling the loads attributable to the high spin rate.

5. ANALYSIS OF THE HEXAGONAL SPLINE

The purpose of the hexagonal spline is twofold. The first is to provide support to the upper portion of the drag device during launch and free flight. The launch forces include a 15,000-g inertial load and a torque load of 307.5 lb-in (34.7 N-m). Secondly, the spline must be small enough to allow the drag blades to be the desired size.

6. BOUNDARY CONDITIONS FOR THE HEXAGONAL SPLINE ANALYSIS

As mentioned previously, the loads on the spline during launch are 15,000 g's of inertial loading and 304.5 lb-in (34.7 N-m) of torque loading. The inertial loading is of concern, since the load has to be absorbed by a small "lip" at the top of the hexagonal portion of the lowermost blade guide bulkhead (see Figure 5). Hand calculations found that this surface area was large enough to withstand the inertial load of 9660 lb. This amount is derived from multiplying 15,000 g's by the intended weight of the uppermost region of the drag device. If relatively large displacement of the uppermost guide occurred, it was assumed that the drag blades would aid in support. Therefore, this boundary condition was not analyzed with the finite element method, but the torque load was.

Figure 7 shows the geometry that was used to perform a three-dimensional, quasi-static, finite element analysis of the hexagonal spline. The geometries have been simplified to allow the analysis to focus on the hexagonal spline. Notice that the spline in the lowermost blade guide is hollow. Common engineering practice dictates that the best torque-transmitting geometry is a hollow tube, which also provides a conduit for wires. Figure 8 shows the finite element model of the assembled lowermost and uppermost blade guides. The model consists of 11,088 linear quadrilateral brick elements, 13,824 nodes, and 384 linear transient contact elements. The contact elements are used to simulate the contact between the sides of the spline and the hexagonal hole. The spline geometry has the material properties of steel, whereas the upper plate that contains the hexagonal hole is made of aluminum 7075-T651. The density of the ring that is attached to the upper plate has been tailored so that the moment of inertia would match the intended moment

of inertia for the entire upper region of the drag device. The material properties of interest for the FEA are shown in Table 2.

FINITE ELEMENT MODEL OF THE HEXAGONAL SPLINE

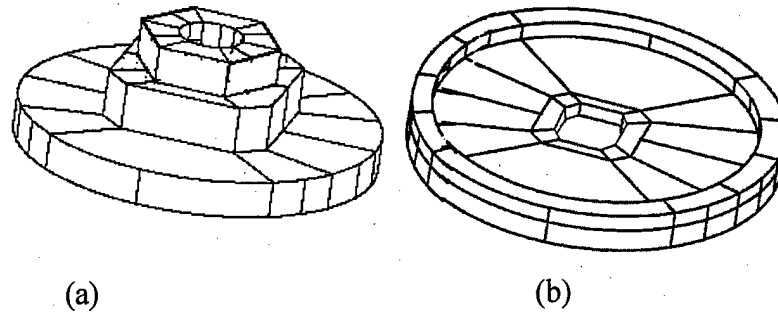

Figure 7. Simplified Geometries of the Lowermost and Uppermost Blade Guides.

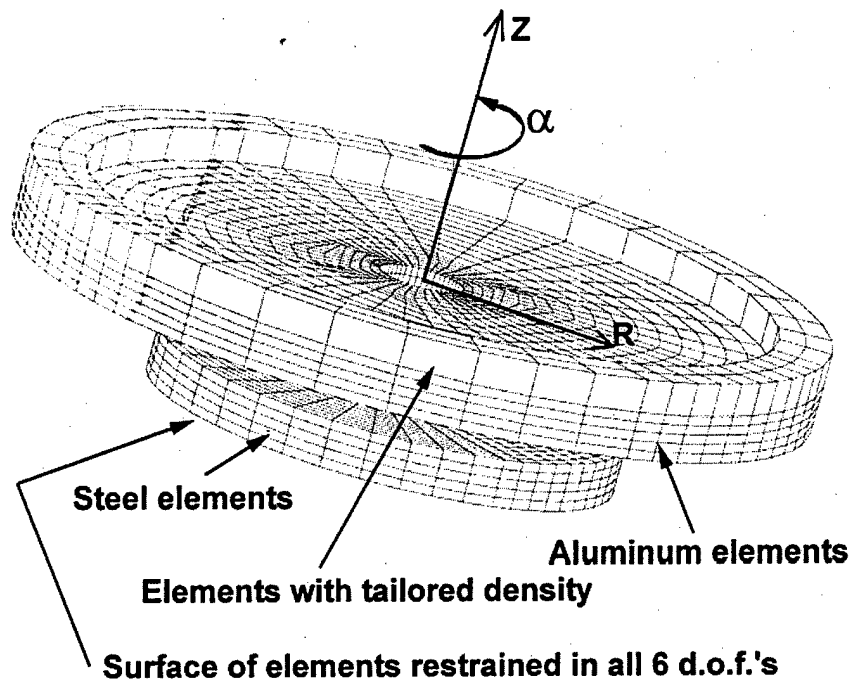

Figure 8. The Finite Element Model of the Assembled Lowermost and Uppermost Blade Guides.

7. RESULTS

The results presented are based on the von Mises stress criterion. This theory specifies that plastic (deformable) yielding will occur when the combined stresses of a body equal or

exceed the tensile stress of a metal. The von Mises stress failure criterion has been validated by previous empirical studies (Sorenson 1992).

Table 2. Material Properties Used for the Finite Element Analysis

Material	Young's Modulus of Elasticity psi [MPa]	Specific Gravity	Poisson's Ratio
Generic Isotropic Steel	30x10 ⁶ [207]	7.83	.29
Aluminum 7076-T651	10x10 ⁶ [69]	2.79	.33
Tailored Mass	10x10 ⁶ [69]	133.58	.29

Von Mises stress, σ' , can be represented by the following equation:

$$\sigma' = \left\{ \left[(\sigma_1 - \sigma_2)^2 + (\sigma_2 - \sigma_3)^2 + (\sigma_1 - \sigma_3)^2 \right] / 2 \right\}^{1/2}$$

in which σ_1 , σ_2 , and σ_3 are the principal stresses and

$$\sigma_1 > \sigma_2 > \sigma_3.$$

Plastic yielding is predicted to occur when the von Mises stress is equal to or greater than the yield stress, σ_{yield} , of the material. If the design has extensive areas of plastic yielding, then it is likely to suffer unacceptable deformations and possibly even fracture in service. However, if only small, localized regions of yielding are predicted, then it is presumed that some redistribution of material through plastic flow will alleviate these high stress areas (Hollis 1997).

Figure 9 shows a cut-away contour plot of the hexagonal spline. Notice that the largest von Mises stress is 77 ksi and is localized to the vertices of the hexagon. This stress is of no concern because the vertices would either be chamfered or filleted, and the choice of steel would have a yield strength of approximately 150 ksi. Figure 10 shows a contour plot of the von Mises stresses on the uppermost blade guide because of the torque loading. Notice that the maximum von Mises stress is 76 ksi, which is 3 ksi higher than the yield strength of aluminum 7075-T651. This does cause some concern; however, the stresses are localized to the vertices of the geometry. Again, the vertices would not exist because the fabrication process would call for the corners to be replaced with small fillets, thus eliminating the stress riser effect of corners.

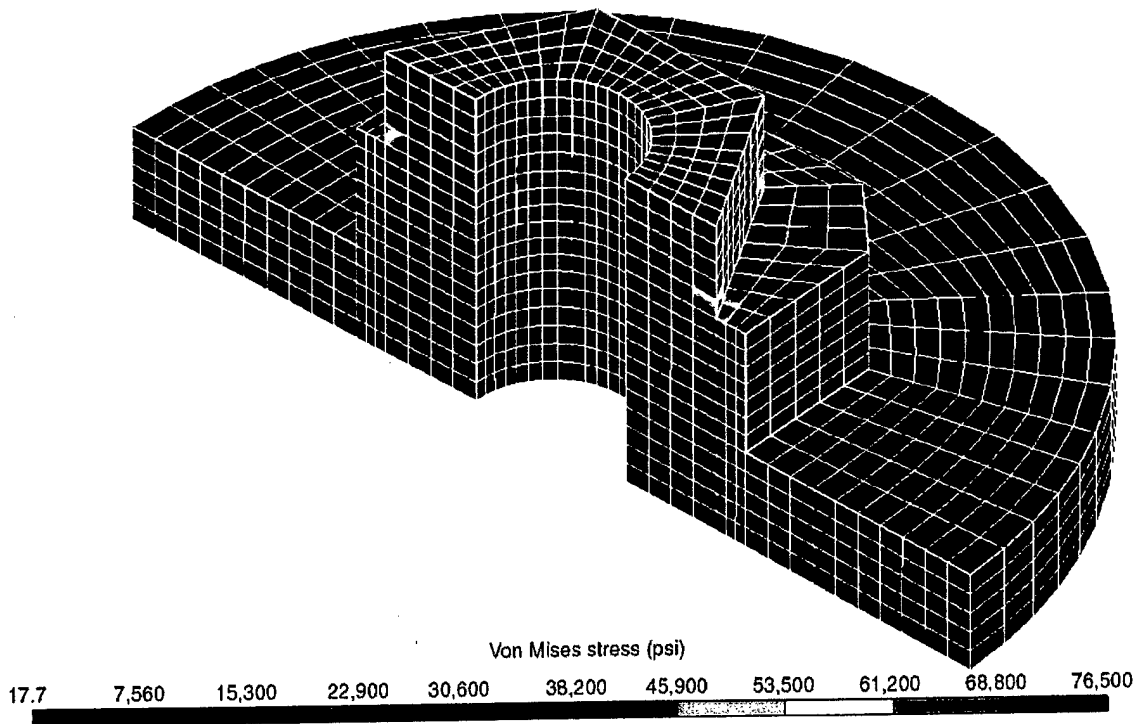

Figure 9. Von Mises Stress Contour Plot of the Hexagonal Spline.

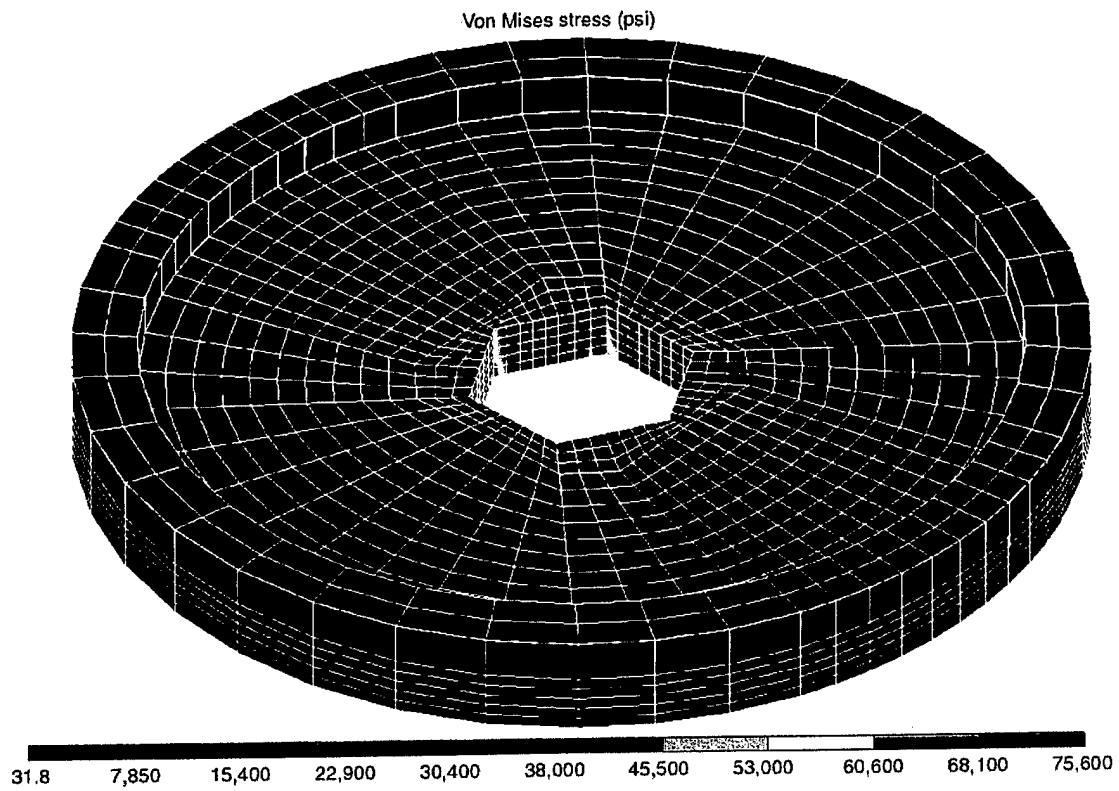

Figure 10. Von Mises Stress Contour Plot of the Uppermost Guide Plate.

8. DESIGN OF THE DRAG BLADE RELEASE DEVICE

Figure 11 displays the drag blade release device and the components, which would retract the pins from the lowermost drag blades. The device is a simple lever type mechanism, in which a micro-miniature piston actuator (MMPA) pushes the crank arm slider and the crank arm alignment pin. The crank arm slider, which can only translate in one direction because of the alignment pin, is linked to two crank arms. The crank arm, as seen in Figure 12, rotates about the pivot point while maintaining a connection with the release pin. The release pin is limited to one degree of freedom, which is a translation only because the pins must slide through guide holes in the release device bulkhead. In addition, the pivot points are maintained in the release device bulkhead. The nacelle houses the entire mechanism, protecting it from electrical potting compound. The MMPA is capable of producing a 60-lbf impulse. The force of the impulse is distributed by the crank arm slider to the crank arms. The crank arm represents a 2.7:1 lever ratio, which amplifies the imparted force of the crank arm slider. A device similar to this was successfully used in bench tests in late 1996 and in an actual flight test at Wallops Island in January 1997.

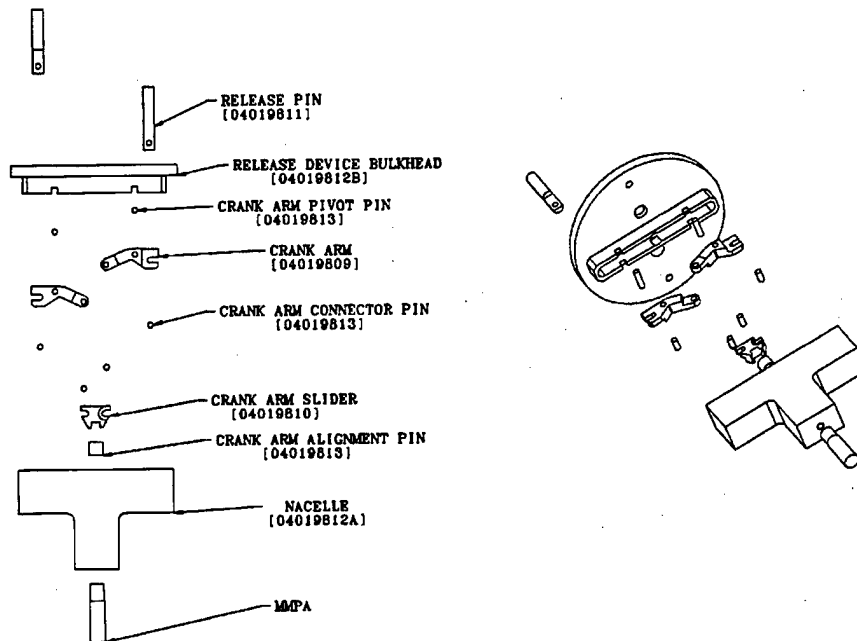

Figure 11. Exploded View of the Drag Blade Release Device.

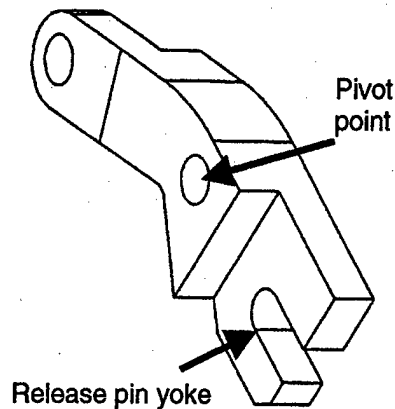

Figure 12. An Isometric View of a Crank Arm From the Drag Blade Release Device Assembly.

9. DESIGN AND ANALYSIS OF THE WINDSHIELD

With the future of artillery projectiles being launched at higher muzzle velocities, i.e., Mach 3, there comes the concern about aerodynamic heating. At Mach 3, there is a possibility of a stagnation temperature of 600° to 700° F (589° to 644°K) occurring on the nose of the windshield. Thorough aerodynamic heating and heat transfer analyses are beyond the scope of this report. Therefore, the design was intentionally over-compensated to handle possible aerodynamic heating for flights with an initial muzzle velocity of Mach 3. Since this design intended to have hardware that telemetered data, the material of the windshield needed to allow for the transmission of radio frequencies. Therefore, a high strength, heat-resistant plastic was chosen. Table 3 lists plastics that were surveyed.

This report focuses on the use of Nylon 66 as the polymer of choice. Nylon 66 is relatively strong, has a high melting point and has the lowest cost. Since none of the plastics surveyed had a melting temperature high enough to withstand the stagnation temperature of 316° to 371° F, a ceramic nose tip was designed. The ceramic of preference was Macor[®], which is produced by Dow Corning. Macor[®] is a machinable ceramic that can withstand temperatures as great as 1000° C and has a thermal conductivity of 1.46 w/m/C°. Both the nylon windshield and the Macor[®] nose tip are shown in Figures 13 and 14. The nose tip merely screws into the windshield. This design was intended to survive the angular acceleration and inertial loading conditions used in the hexagonal spline analysis mentioned earlier. A quasi-static, linear analysis was performed on the assembly of the windshield and the nose tip. Even though the windshield is nylon, the analysis was intended to determine how much linear deformation the windshield would incur. If the deformation and the stresses diverged from the linear regime, then the

analysis would not be valid. On the other hand, if the analysis remained linear, the assembly would then be fabricated and tested on a shock table.

Table 3. Material Properties of Surveyed Plastics

Polymer Description at 73° F	Nylon 101 Type 66	Unfilled Polycarbonate	Unfilled Polyetherimide	Polyphenylene Sulfide	Unfilled Polyetherether Ketone	Polyamideimide
Tensile Strength (psi)	11,500	10,500	16,500	13,500	16,000	18,000
Compressive Strength, 10% Deformation (psi)	12,500	11,500	22,000	21,500	20,000	28,000
Tensile Modulus (psi)	425,000	320,000	475,000	500,000	500,000	600,000
Melting Point (F)	500	n/a	n/a	540	644	n/a
Tg-Glass Transition (F)	n/a	293	419	n/a	n/a	527
Dielectric Constant, 10 ⁶ Hz	3.6	3.17	3.15	3.0	3.3	3.9
Relative Cost	\$	\$\$	\$\$\$	\$\$\$\$	\$\$\$\$\$	\$\$\$\$\$

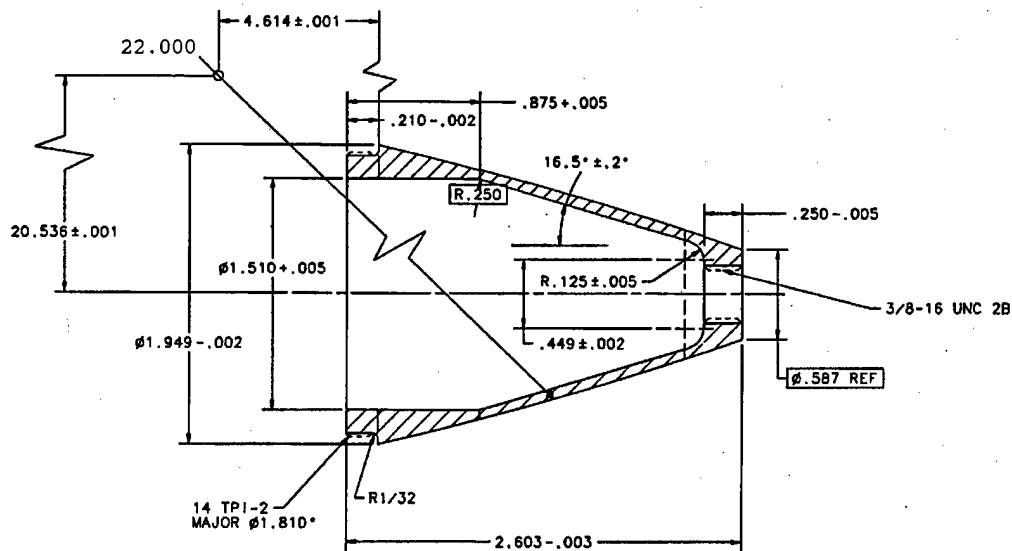

Figure 13. Schematic of the Nylon Windshield.

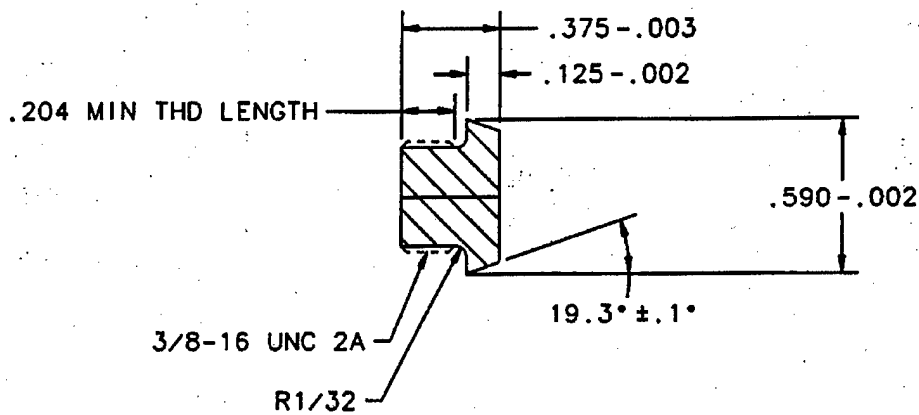

Figure 14. Schematic of the Ceramic Nose Tip.

10. BOUNDARY CONDITIONS OF THE WINDSHIELD FINITE ELEMENT ANALYSIS

The loads that were used in the hexagonal spline analysis were also used in this analysis. Figure 15 depicts how the loads were applied to the geometry. The inertial set-back load of 15,000 g's is applied along the centerline axis, while an angular acceleration of 150,000 rad/s² is also applied along the positive sense of this axis. In addition, the surface where the threads are to be located is restrained in the axial, radial, and theta directions. The bottom surface of the windshield is also restrained in the axial direction. Figure 16 represents the finite element model used to evaluate the windshield assembly. The nodes at the threaded interface between the nose tip and the windshield were merged to simulate the threads. Four hundred twenty (420) transient contact elements were used to model the interface between the bottom of the insert and the top of the windshield. The model incorporated 13,260 linear quadrilateral brick elements and 18,872 nodes.

11. RESULTS

The axial, radial, and hoop stresses were used to evaluate the windshield assembly. Figure 17 displays the axial stresses that were present in the finite element model. One can see that the maximum stress is approximately -2070 psi (-14.3 MPa) with a maximum axial displacement of -0.0056 inch (-0.14 mm). The axial deflection is on the order of 0.2% of the overall length, and the level of stress is well below the 12,000-psi compressive strength of Nylon type 66.

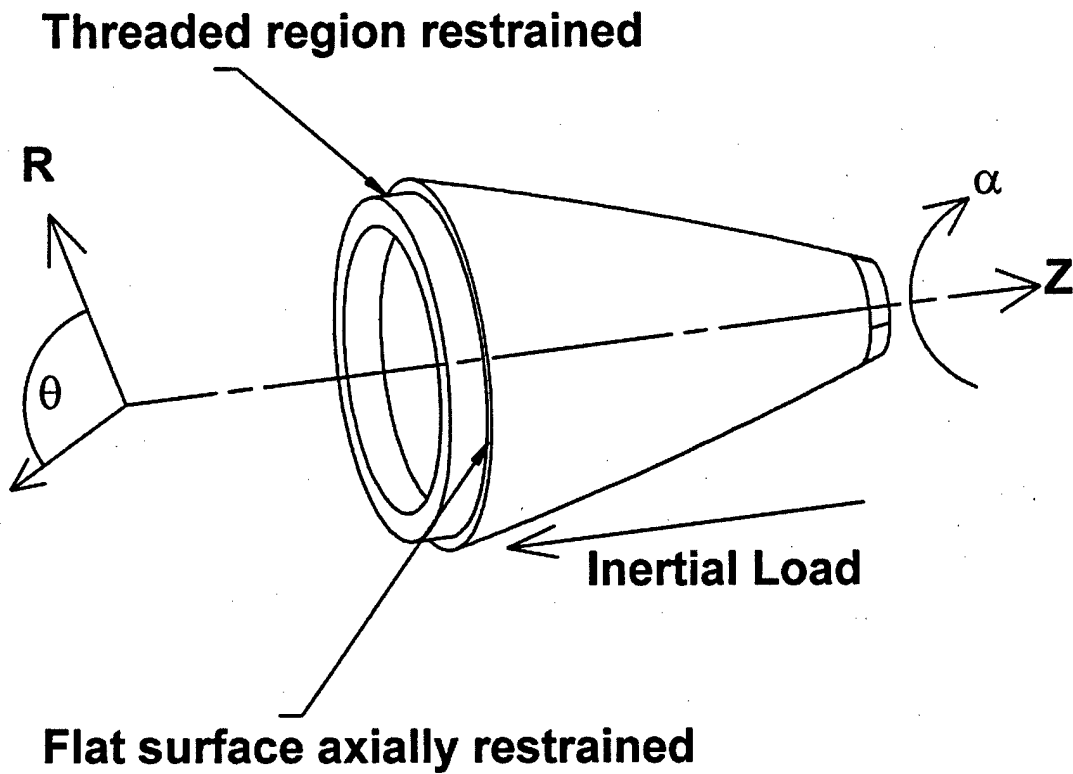

Figure 15. Boundary Conditions and Restraints of the Windshield Model.

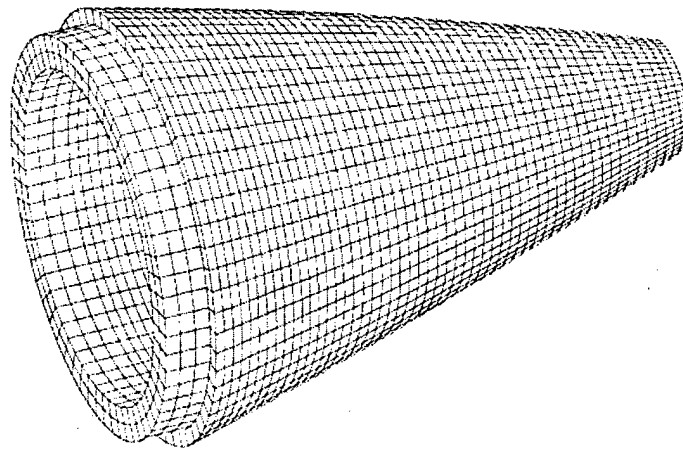

Figure 16. Finite Element Model of the Windshield.

The radial and hoop stresses were much lower in magnitude of stress than the axial component. The maximum radial component of stress was 1,450 psi (10 MPa) and the maximum component of the hoop stress was 860 psi (6 MPa).

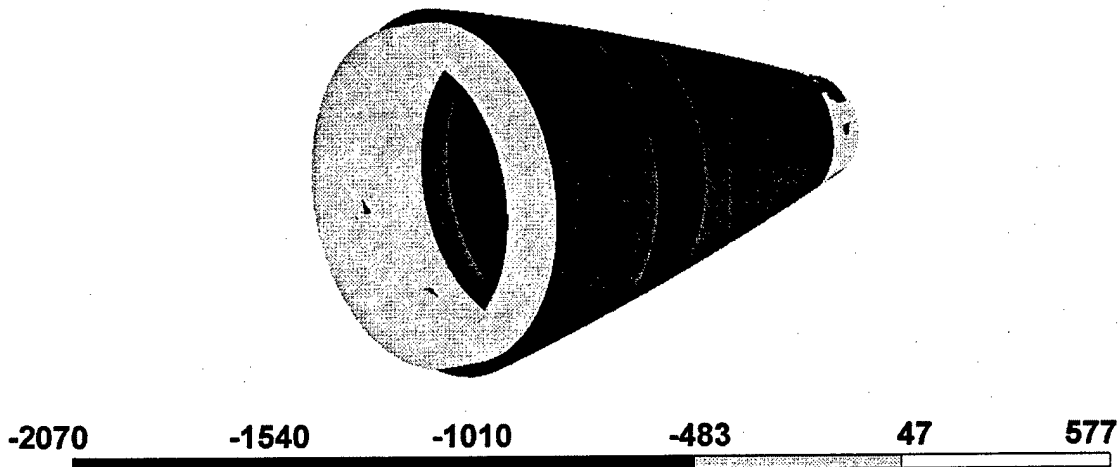

Figure 17. Axial Stress Contour Plot of the Windshield Model.

12. TESTING OF THE WINDSHIELD

In addition to the structural analysis, the windshield assembly was shocked on an Impact shock test machine. Two separate windshield assemblies were tested. The test applied 15,000 g's for approximately 0.01 millisecond. No noticeable permanent deformation was witnessed, thus verifying the inertial loading part of the analysis. However, one will argue that nylon is a rate-dependent material and that this analysis does not cover this topic. This much is true. The scope of this report was to estimate the viability of the design using linear numerical tools. Since the shock table testing, several windshield assemblies have been fabricated and successfully flight tested. To date, the fastest launch was from a smooth bore, 120-mm gun tube at Mach 3. The fastest artillery gun launch to date was Mach 2.4 with a spin rate of approximately 250 Hz.

13. CONCLUSION

This report is a culmination of many design iterations, numerical analyses, shock tests, and actual cannon launchings. Most of the design iterations and numerical analyses are not mentioned in this report simply because they were stepping stones that led to the final design. Structural analyses indicate that the overall prototype design is durable enough to withstand the most severe artillery cannon launching available today. The design should be capable of withstanding 15,000 g's of inertial set-back loads with 150,000 rad/s² of angular acceleration. In addition, the design is also capable of deploying at a velocity of 650 m/s while spinning at 250 cycles per second. The next step would be to fabricate the design in order to truly verify the integrity of the structure and to determine the overall effect of the deployed drag blades on the range of flight.

Further development would be to incorporate the drag mechanism into an actual fuze. Figure 18 displays the M773 multi-option fuze artillery (MOFA) and a layout of the incorporation of the range corrector concept within the MOFA. This figure demonstrates that the range corrector-MOFA could be a possibility. A portion of the fuze would be extended enough to insert the drag-producing blades and to re-route wires via a central conduit which the range corrector provides.

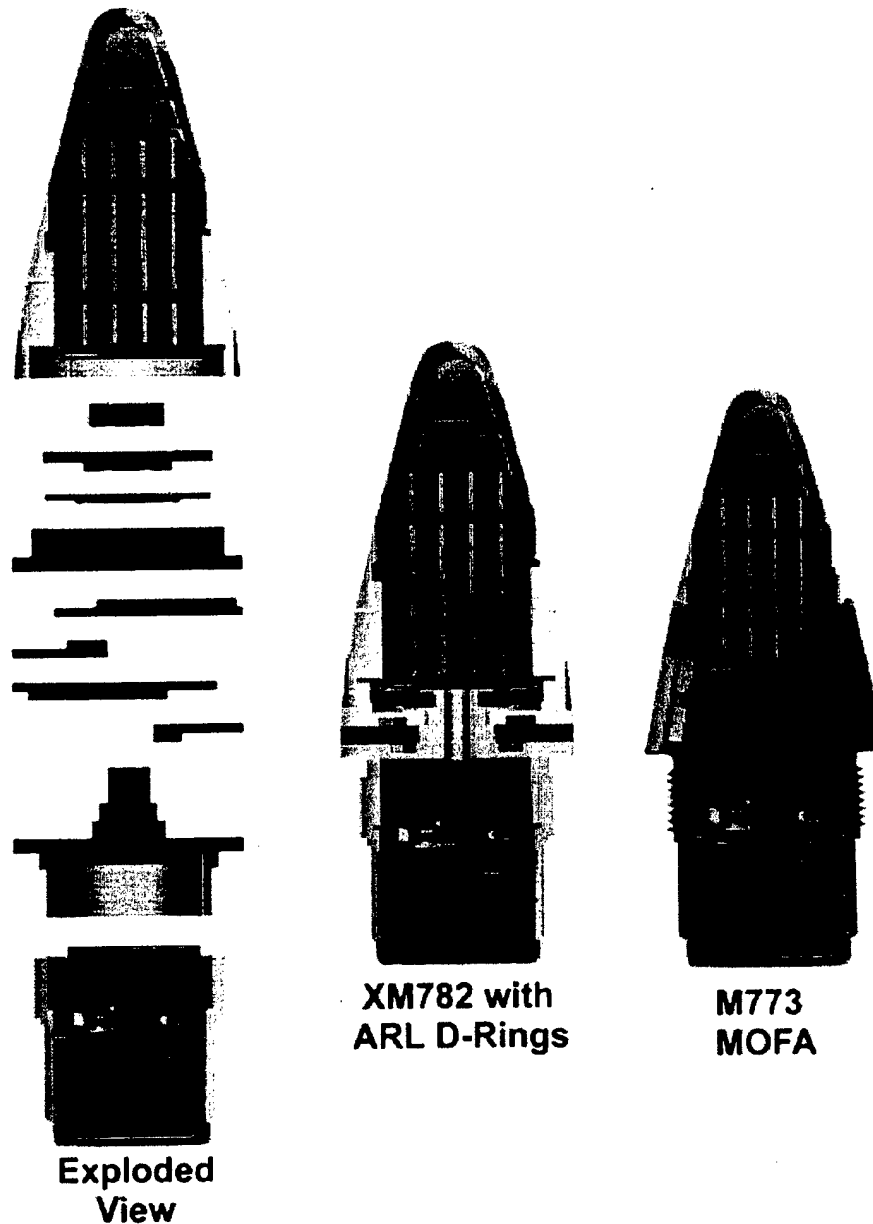

Figure 18. The M773 MOFA and a Possible Incorporation of the Range Corrector Device.

INTENTIONALLY LEFT BLANK

REFERENCES

- D'Amico, W. "Low-cost Competent Munitions (LCCM) Self-Correction Devices-An Initial Study and Status," ATL-TR-1178, U.S. Army Research Laboratory, Aberdeen Proving Ground, Maryland, 1996.
- Hollis, M. "Preliminary Design of a Range Correction Module for an Artillery Shell," ARL-MR-298, U.S. Army Research Laboratory, Aberdeen Proving Ground, Maryland, 1996.
- Hollis, M. "Structural Analysis of the Deployed Drag Surfaces of a Range Correction Module concept for Low Cost Competent Munitions (LCCM)," ARL-TN-103, U.S. Army Research Laboratory, Aberdeen Proving Ground, Maryland, 1998.
- Sorenson, B. "Design and Analysis of Kinetic energy Projectile Using Finite-Element Optimization," Proceedings of the ANSYS fifth International conference and Exhibition, Vol 3, 1992.

INTENTIONALLY LEFT BLANK

APPENDIX A

SCHEMATICS FOR RANGE CORRECTION CONCEPT
WITH VARIABLE DEPLOYMENT D-RINGS

INTENTIONALLY LEFT BLANK

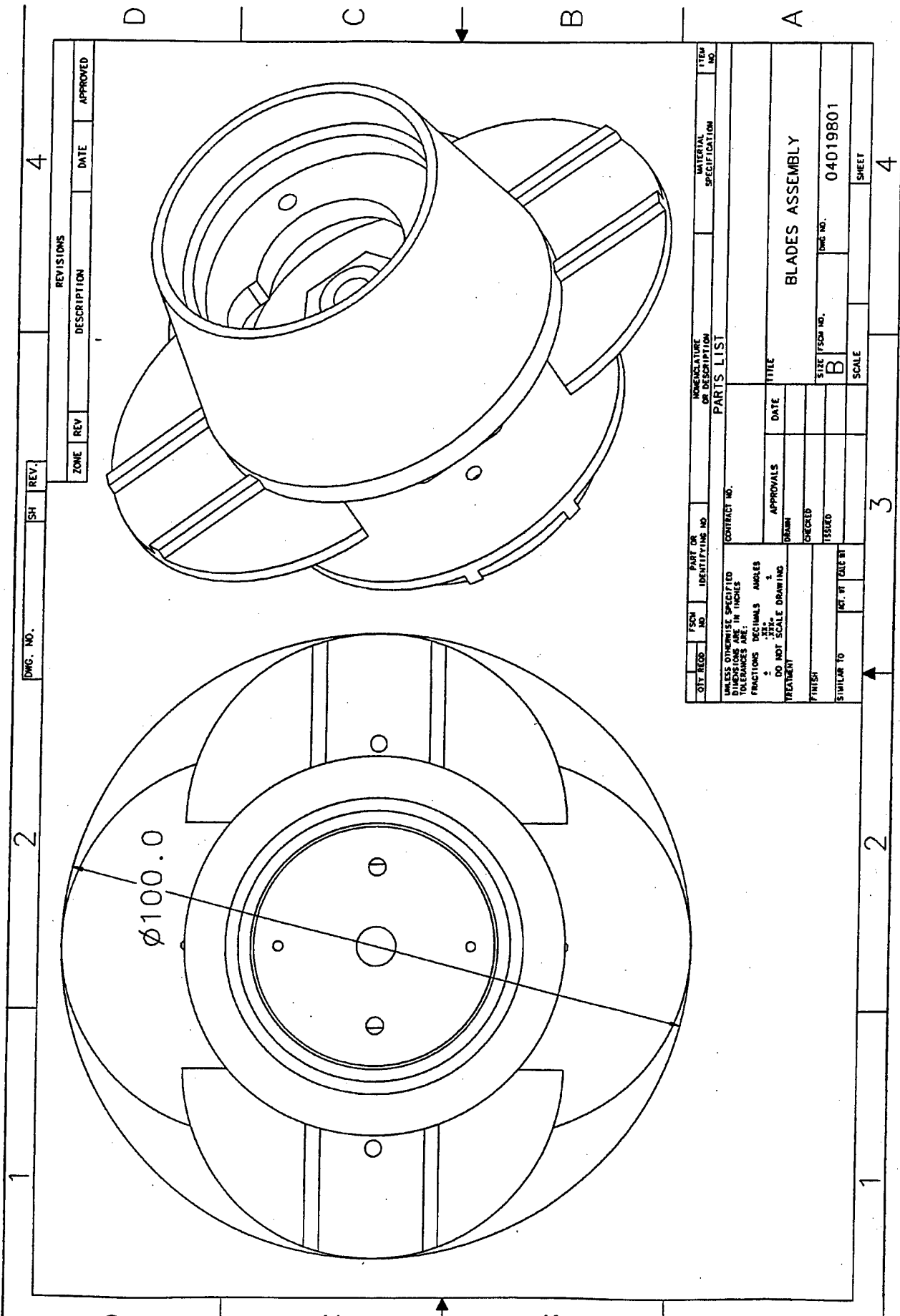

REVISIONS		DATE	APPROVED
ZONE	REV		

DWG. NO. SH REV. 4

CITY	FSCH NO.	PART OR IDENTIFYING NO.	NOMENCLATURE OR DESCRIPTION	MATERIAL SPECIFICATION	STEP NO.
PARTS LIST					
UNLESS OTHERWISE SPECIFIED DIMENSIONS ARE IN INCHES			CONTRACT NO.		
FRACTIONS DECIMALS ANGLES			TITLE		
DO NOT SCALE DRAWING			BLADES ASSEMBLY		
TREATMENT	APPROVALS	DATE	SITE TECH. NO. B 04019801		
FINISH	CHECKED		SCALE		
SIMILAR TO	TESTED		SHEET		
NET WT	DATE BY		4		

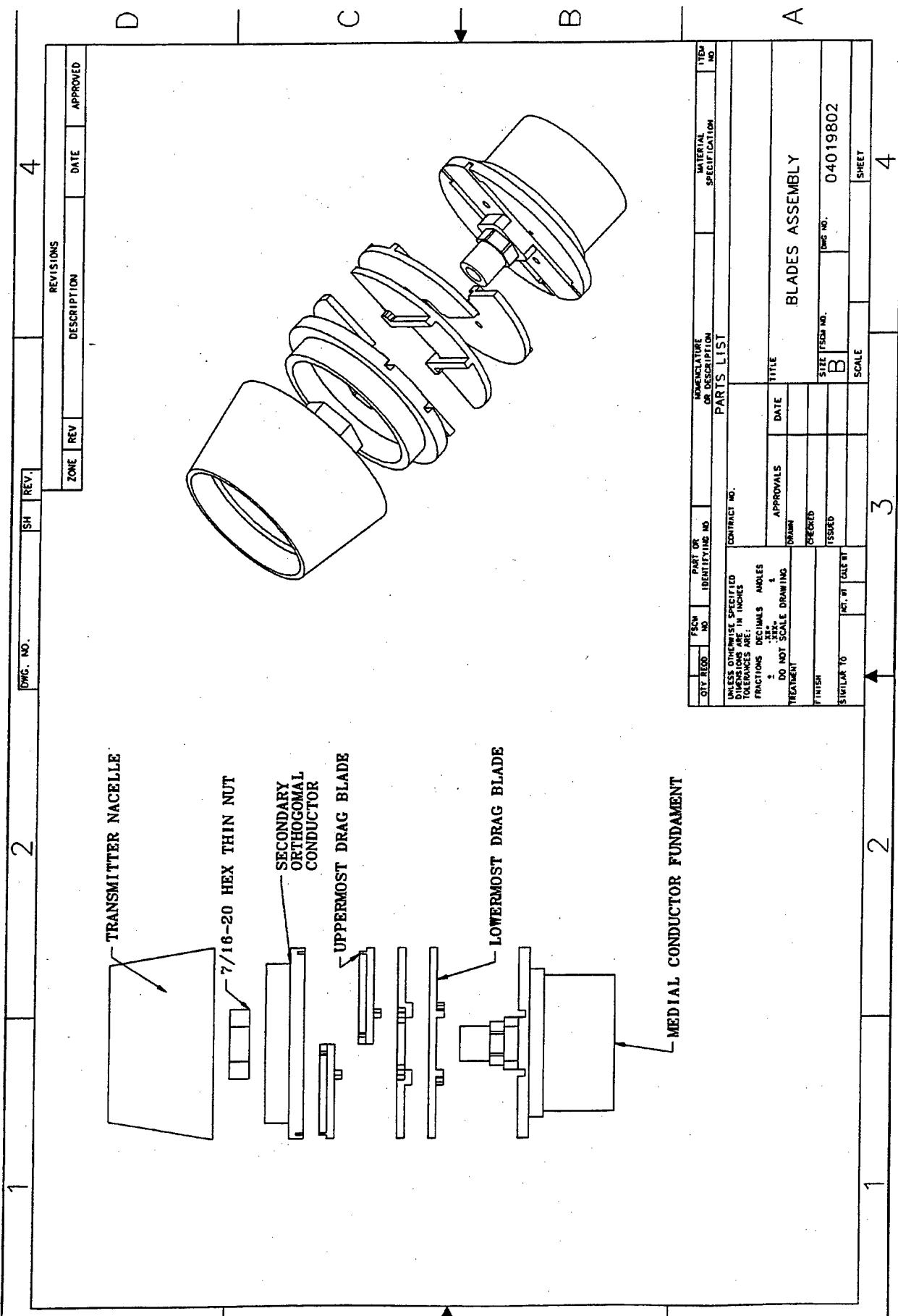

DWG. NO.	SH	REV.	REVISIONS	
1	2	4	DESCRIPTION	DATE
1	2	4	APPROVED	

QTY.	TSCH. NO.	PART OR IDENTIFYING NO.	INVENTORY OR DESCRIPTION	MATERIAL SPECIFICATION	ITEM NO.
PARTS LIST					
UNLESS OTHERWISE SPECIFIED IN INCHES TOLERANCES ARE:			CONTRACT NO.		
1	2	3	4	5	6
FRACTIONS	DECIMALS	ANGLES	DO NOT SCALE DRAWING	APPROVALS	DATE
TREATMENT	FINISH	SIMILAR TO	ACT. WT. (G/LB. W)	CHECKED	ISSUED
TITLE			BLADES ASSEMBLY		
SIZE (TSCH. NO.)			DWG. NO. 04019802		
SCALE			SHEET		
1			2		
3			4		

REV	DESCRIPTION	DATE	APPROVED

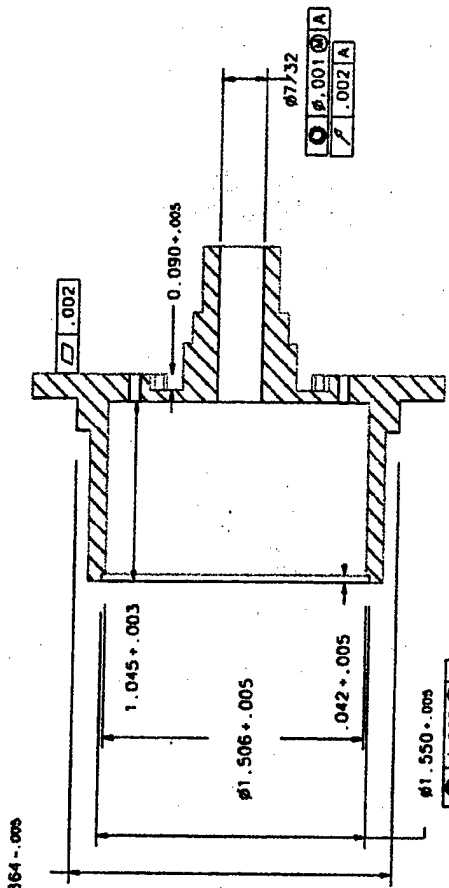

VIEW A-A

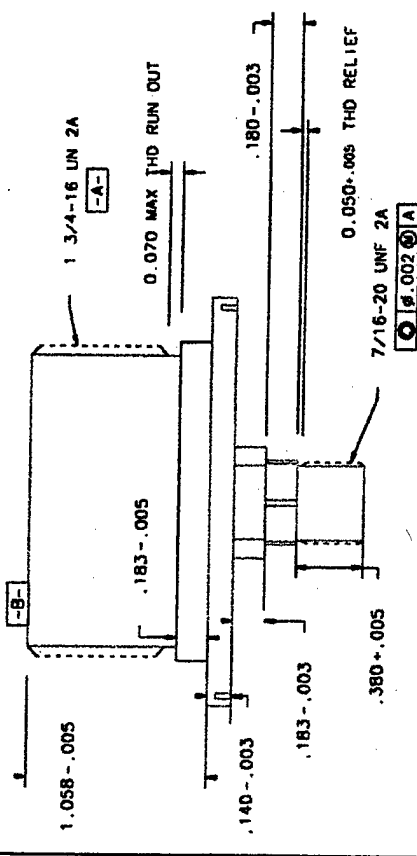
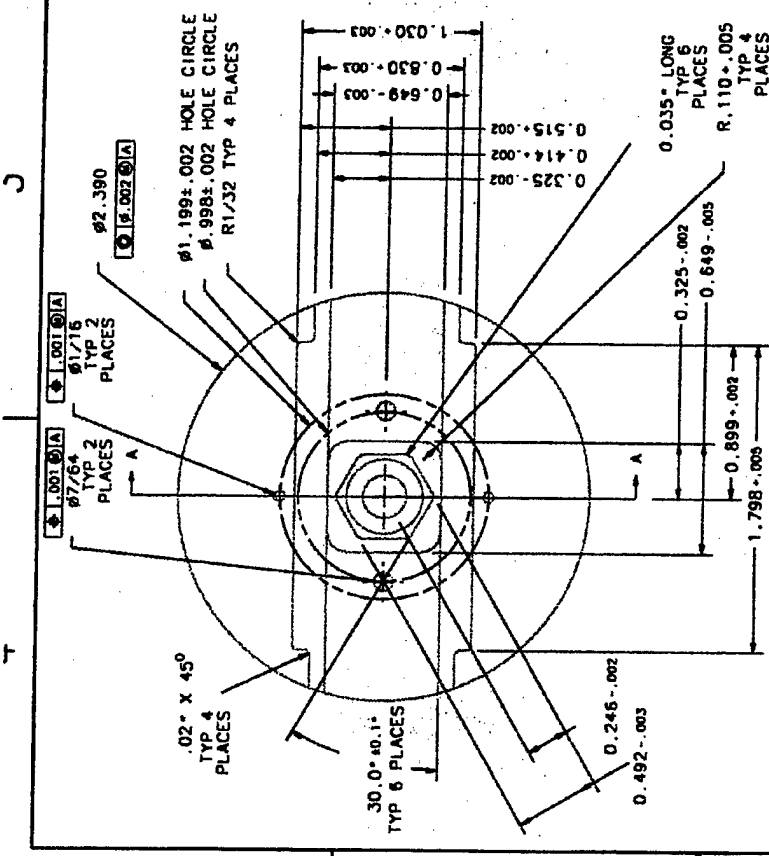
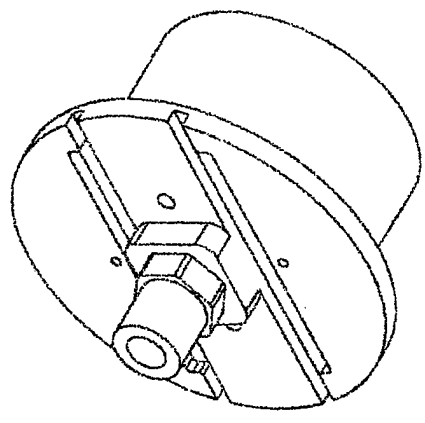

NOTE: NEED 7/16-20 HEX THIN NUT GRADE 8-5 UNITS

REV	DATE	DESCRIPTION	APPROVED

MATERIAL: STEEL MIN YIELD: 150,000 PSI

PARTS LIST

ITEM NO.	QTY	DESCRIPTION	UNIT

LOWERMOST BLADE GUIDE BULKHEAD

DATE: 04019803

SCALE: 1:1

SHEET: 1

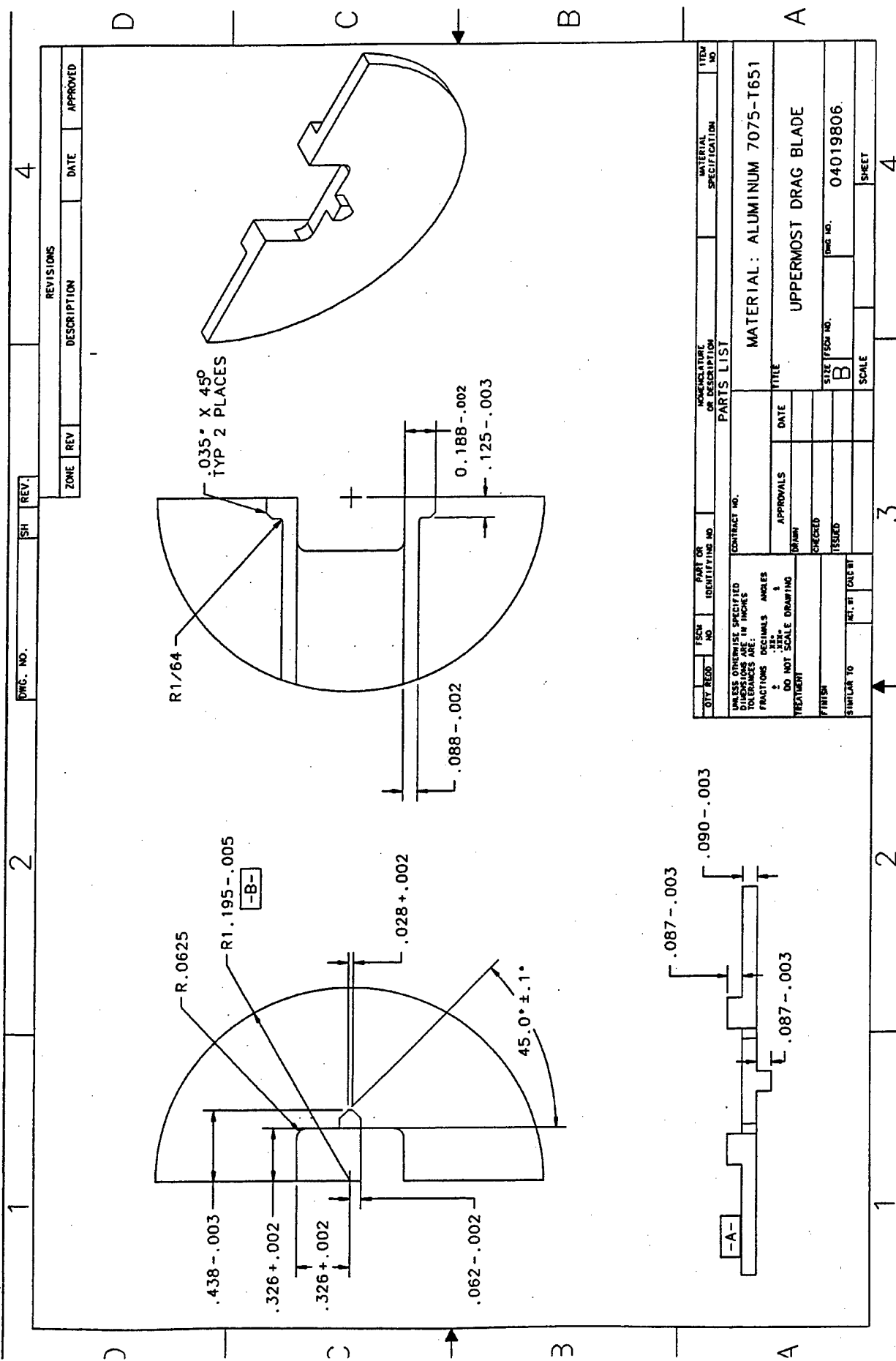

REV. NO.		SH		REV.	
1	2	3	4		

REVISIONS				
ZONE	REV	DESCRIPTION	DATE	APPROVED

CITY	ESCH. NO.	PART OR IDENTIFYING NO.	UNLESS OTHERWISE SPECIFIED	TITUM NO.
			PARTS LIST	
MATERIAL: ALUMINUM 7075-T651			TITLE	
UPPERMOST DRAG BLADE			DATE	
CONTRACT NO.			APPROVALS	
FINISH			DRAWN	
CHECKED			ISSUED	
STUBS TO			SCALE	
AS. PT. CAL. PT.			SHEET	
1			4	
2			3	
3			4	

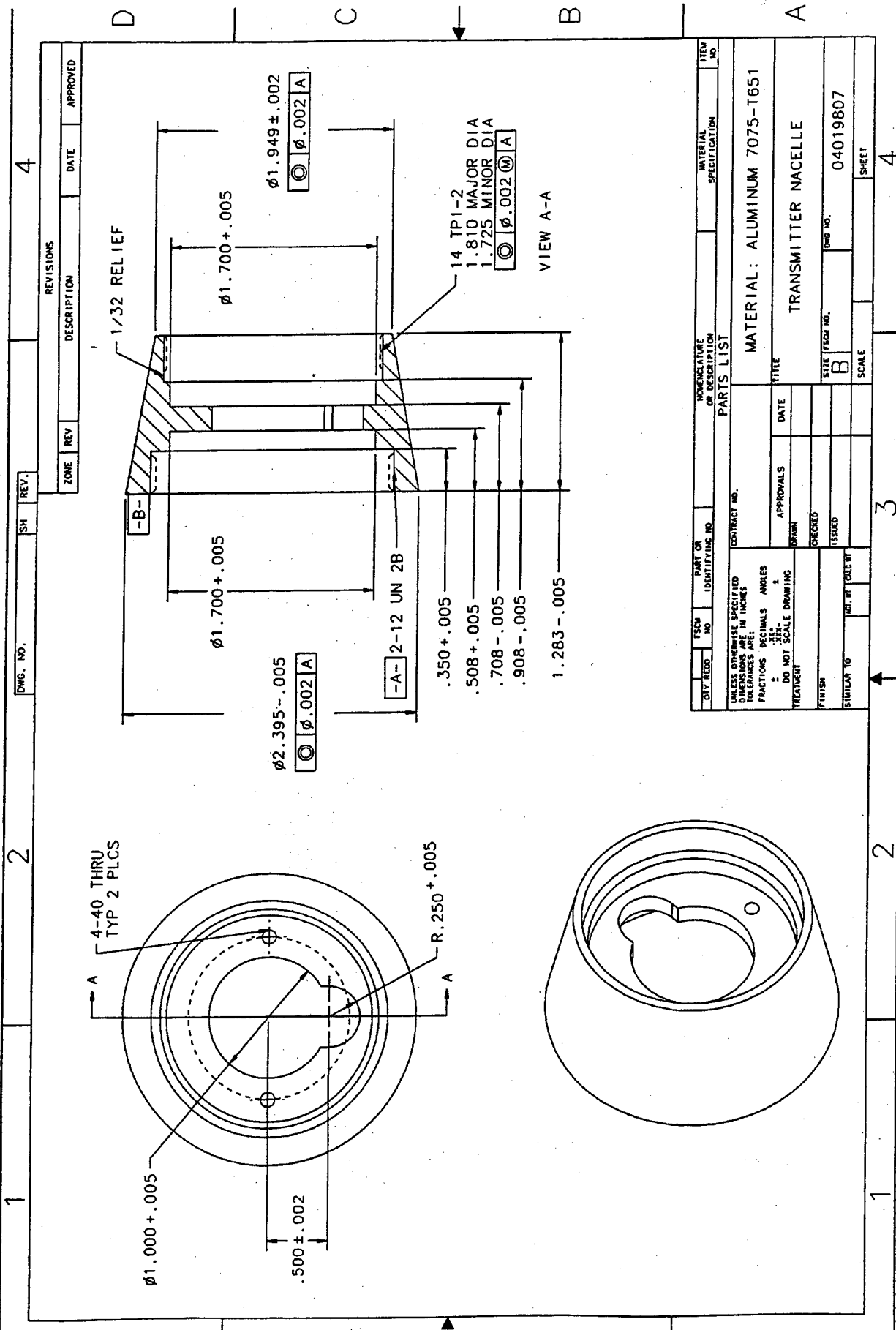

1	2	4
REV.	DATE	APPROVED
DESCRIPTION	REVISIONS	
ZONE	REV	

DWG. NO.	SH	REV.
----------	----	------

CITY	FEED	PART OR IDENTIFYING NO.	SIGNATURE OR DESCRIPTION	TITLE
UNLESS OTHERWISE SPECIFIED DIMENSIONS ARE IN INCHES TOLERANCES ARE: FRACTIONS DECIMALS ANGLES				
DO NOT SCALE DRAWING TREATMENT				
CONTRACT NO.				
PARTS LIST				
MATERIAL: ALUMINUM 7075-T651				
TRANSMITTER NACELLE				
FINISH				
SIMILAR TO				
APPROVALS				
DATE				
SIZE				
DWG. NO. 04019807				
SCALE				
SHEET				

1	2	3	4
---	---	---	---

1	2	3	4
---	---	---	---

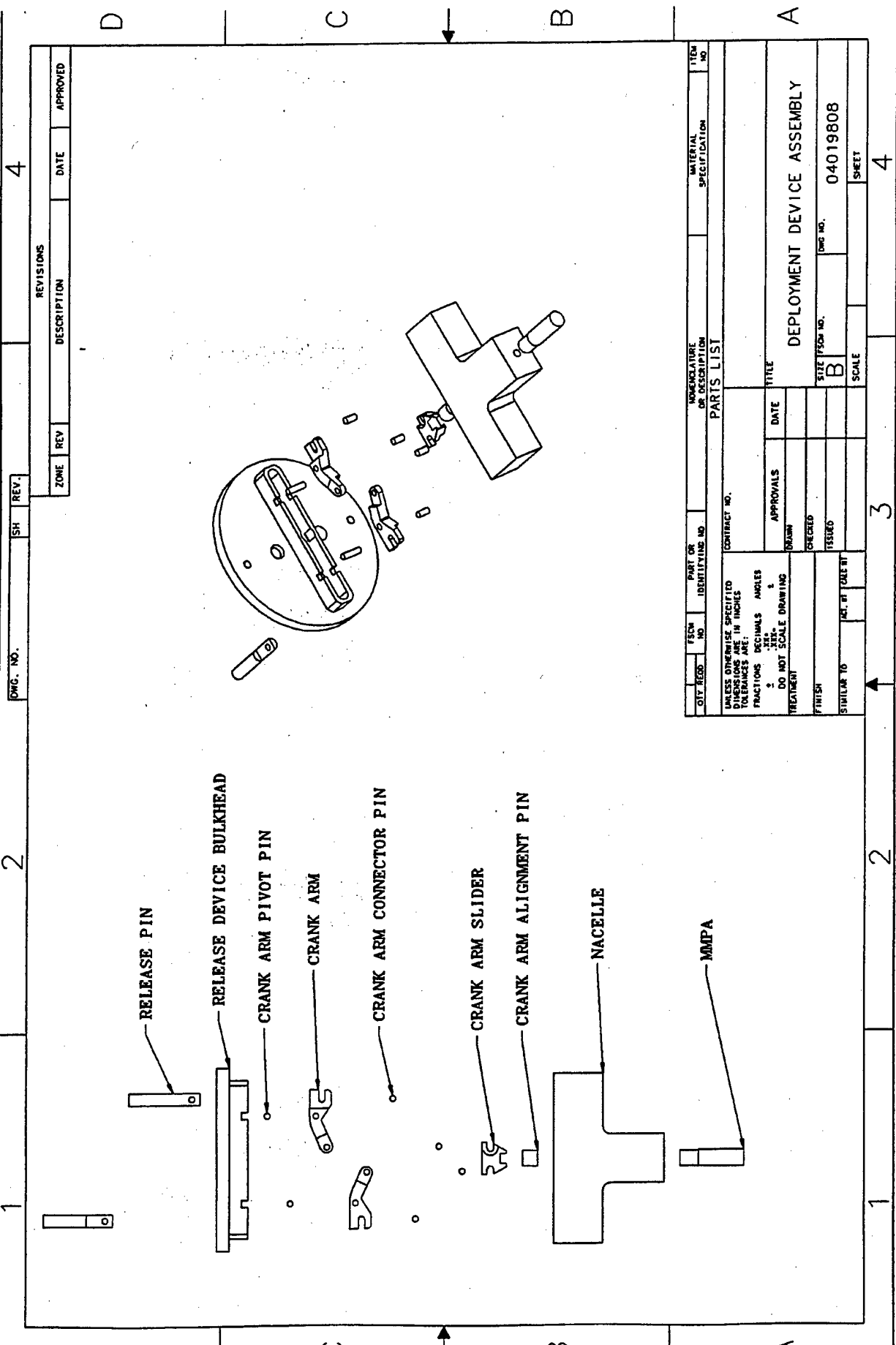

DMG. NO.	SH	REV.	REVISIONS	
1	2	4	DESCRIPTION	DATE
1	2	4	APPROVED	

CITY	FROM NO.	PART OR IDENTIFYING NO.	SIGNATURE OR DESCRIPTION	MATERIAL SPECIFICATION	ITEM NO.
			CONTRACT NO.		
UNLESS OTHERWISE SPECIFIED DIMENSIONS ARE IN INCHES TOLERANCES ARE:			PARTS LIST		
1	2	3	4	5	6
FRAC.	DEC.	ANGLES	APPROVALS	DATE	TITLE
2	3	4	5	6	7
DO NOT SCALE DRAWING			DEPARTMENT		
TREATMENT			CHECKED		
FINISH			TESTED		
SIMILAR TO			SCALE		
MATERIAL			DWG. NO.		
			04019808		
			SHEET		
			4		

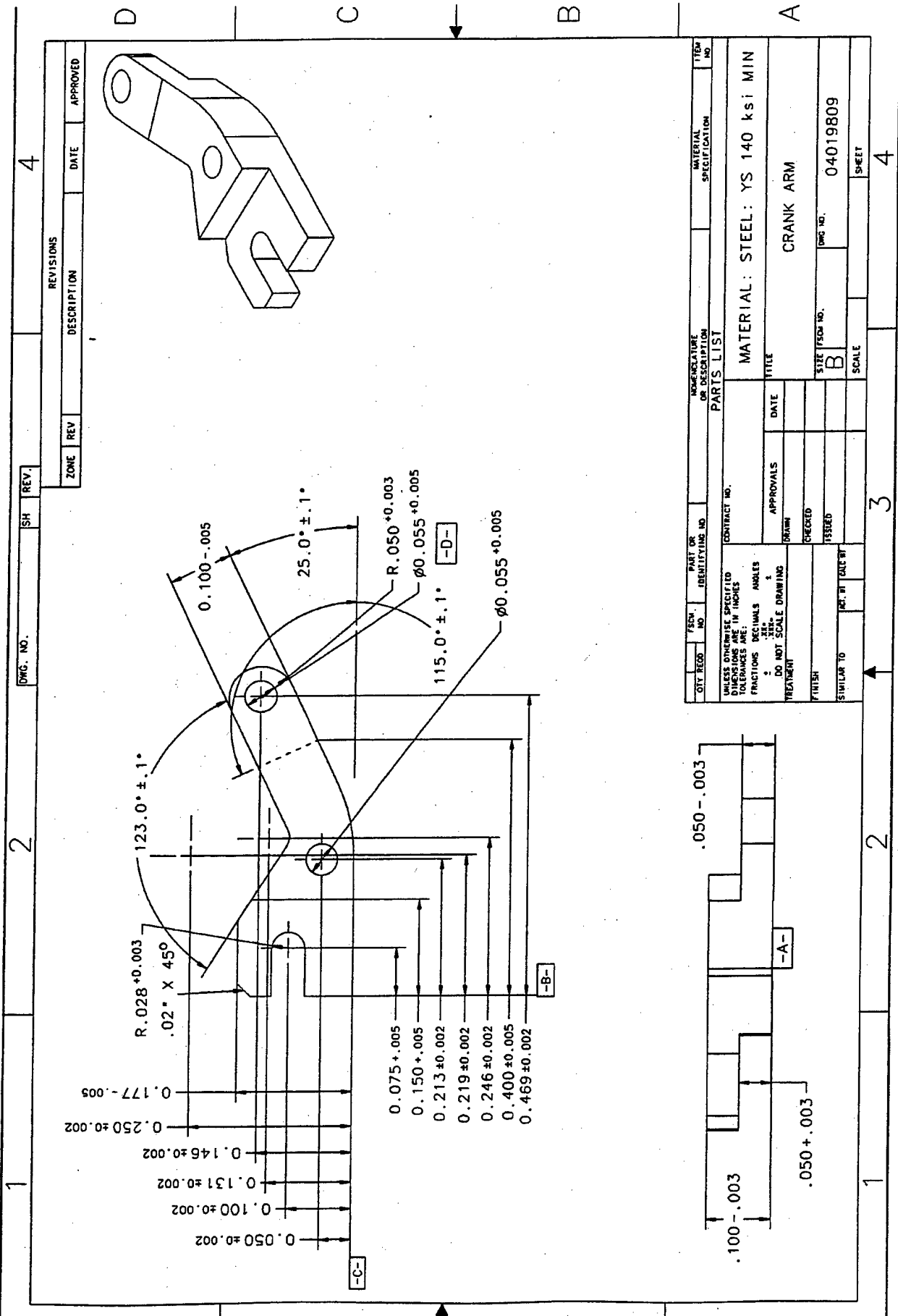

1 2 3 4

ZONE	REV	DESCRIPTION	DATE	APPROVED

SH REV.

4

3

2

1

4

3

2

1

4

3

2

1

4

3

2

1

4

3

2

1

4

3

2

1

4

3

2

1

4

3

2

1

30

4

3

2

1

4

3

2

1

4

3

2

1

4

3

2

1

4

3

2

1

4

3

2

1

4

3

2

1

4

3

2

1

4

3

2

4

3

2

1

4

3

2

1

4

3

2

1

4

3

2

1

4

3

2

1

4

3

2

1

4

3

2

1

4

3

2

1

4

3

2

1

4

3

2

1

4

3

2

1

4

3

2

1

4

3

2

1

4

3

2

1

4

3

2

1

4

3

2

1

4

3

2

1

4

3

2

1

4

3

2

1

4

3

2

1

4

3

2

1

4

3

2

1

4

3

2

1

4

3

2

1

4

3

2

1

4

3

2

1

4

3

2

1

4

3

2

1

4

3

2

1

4

3

2

1

4

3

2

1

4

3

2

1

4

3

2

1

4

3

2

1

4

3

2

1

4

3

2

1

4

3

2

1

4

3

2

1

4

3

2

1

4

3

2

1

4

3

2

1

4

3

2

1

4

3

2

1

4

3

2

1

4

3

2

1

4

3

2

1

4

3

2

1

4

3

2

1

4

3

2

1

4

3

2

1

4

3

2

1

4

3

2

1

4

3

2

1

4

3

2

1

4

3

2

1

4

3

2

1

4

3

2

1

4

3

2

1

4

3

REVISIONS		
ZONE	REV	APPROVED

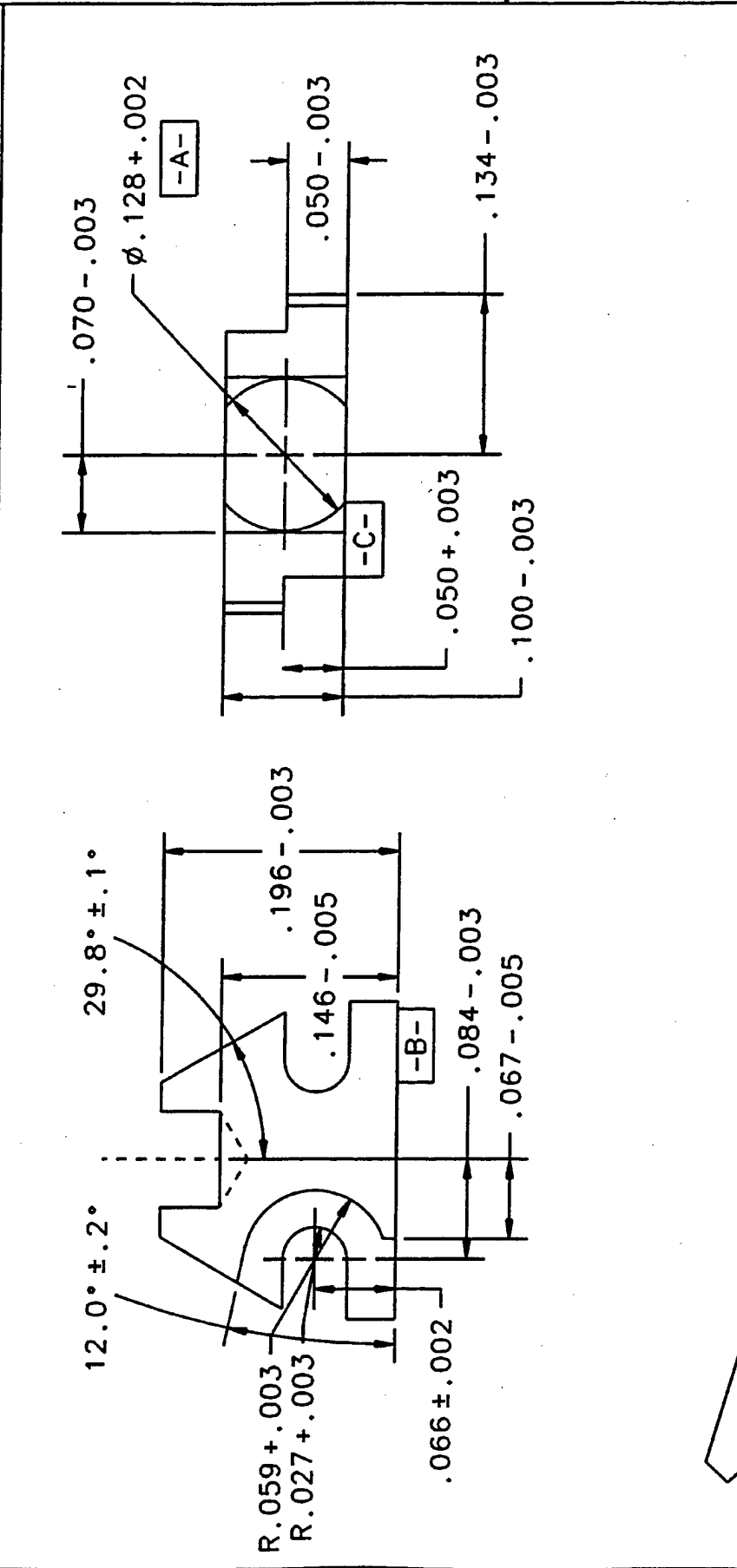

QTY	FSCM NO	PART OR IDENTIFYING NO	NOMENCLATURE OR DESCRIPTION	MATERIAL SPECIFICATION	ITEM NO
PARTS LIST					
UNLESS OTHERWISE SPECIFIED DIMENSIONS ARE IN INCHES			MATERIAL: STEEL 4340		
FRACTIONS DECIMALS ANGLES			TITLE		
= .XX = .XXX = °			CRANK ARM SLIDER		
DO NOT SCALE DRAWING			SIZE FSCM NO. DWG NO.		
TREATMENT			A		
FINISH			SCALE		
SIMILAR TO			SHEET		
ACT. WT (CALC WT)					
APPROVALS			DATE		
DRAWN					
CHECKED					
ISSUED					

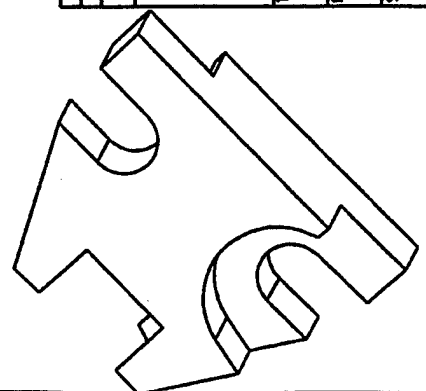

DWC. NO.		SH		REV.	
REVISIONS					
ZONE	REV	DESCRIPTION	DATE	APPROVED	

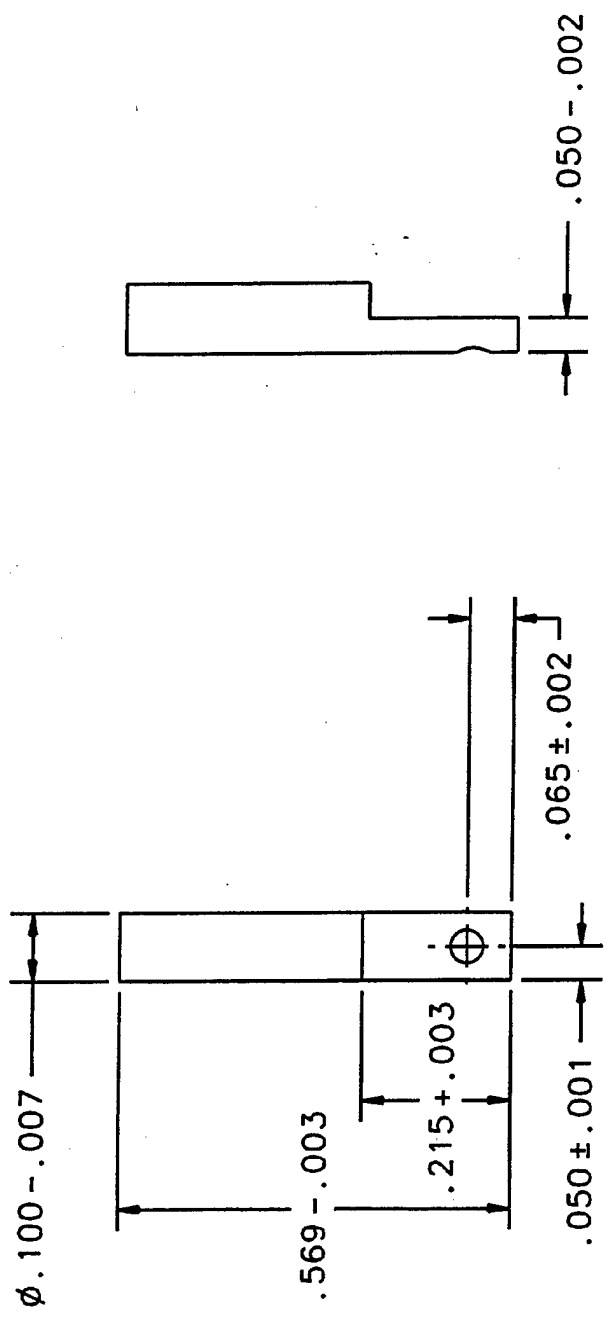

QTY RECD	FSCM NO	PART OR IDENTIFYING NO	NOMENCLATURE OR DESCRIPTION	MATERIAL SPECIFICATION	ITEM NO
PARTS LIST					
UNLESS OTHERWISE SPECIFIED DIMENSIONS ARE IN INCHES TOLERANCES ARE: FRACTIONS DECIMALS ANGLES 1/16 .001 1/2 1/32 .0005 1/4 DO NOT SCALE DRAWING			CONTRACT NO.		
TREATMENT	APPROVALS	DATE	TITLE		
FINISH	CHECKED		RELEASE PIN		
SIMILAR TO	ISSUED		SIZE FSCM NO.	DWG NO.	
			A	04019811	
			SCALE	SHEET	

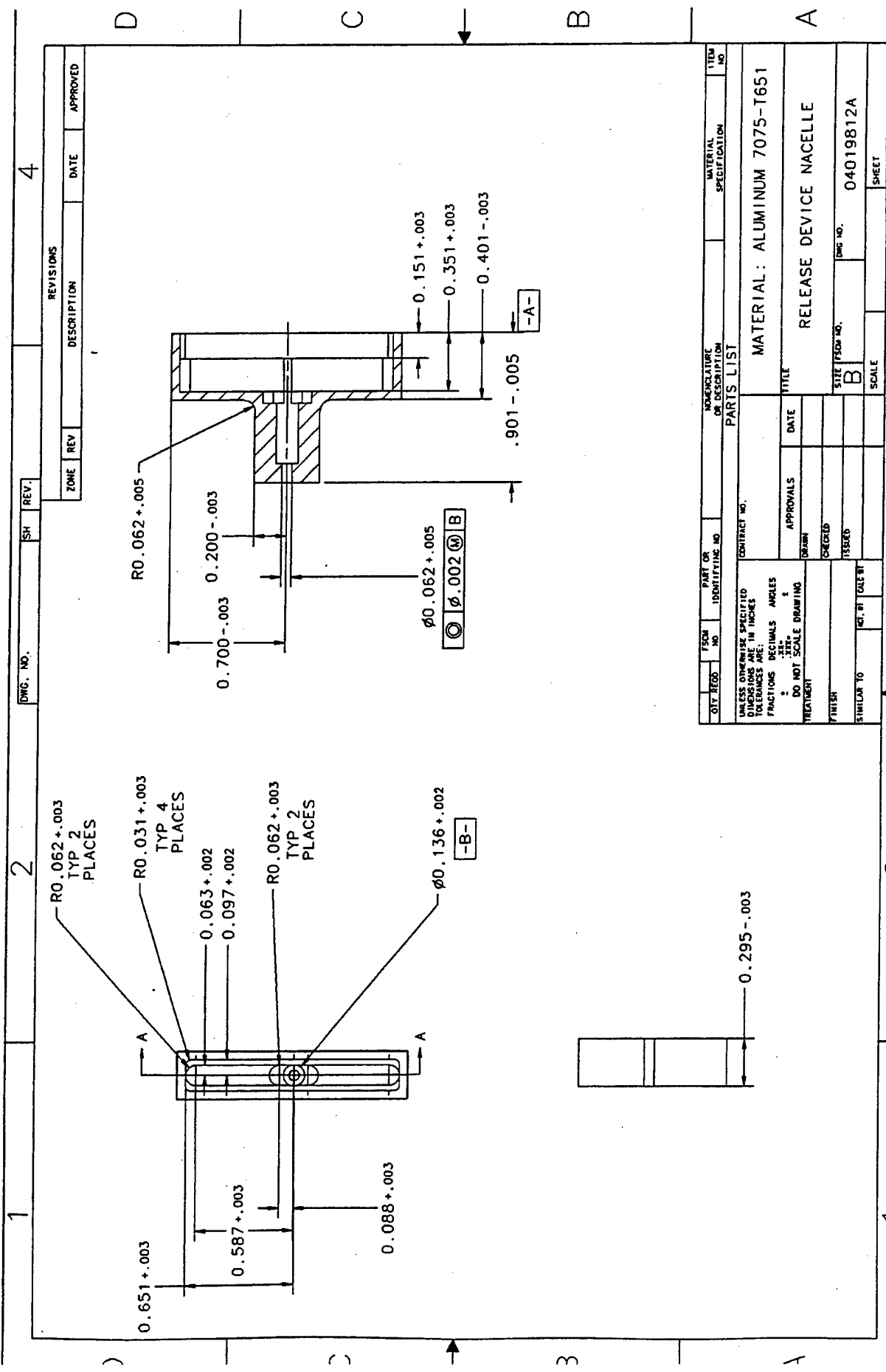

Dwg. No.		SH		REV.		4	
REVISIONS				DATE		APPROVED	
ZONE	REV	DESCRIPTION		DATE		APPROVED	

QTY	REQD	FECH	NO	PART OR IDENTIFYING NO	ALPHABETIC OR DESCRIPTION	MATERIAL SPECIFICATION	ITEM NO
PARTS LIST							
MATERIAL: ALUMINUM 7075-T651				TITLE			
RELEASE DEVICE NACELLE				DATE			
CONTRACT NO.				DRAWN			
APPROVALS				CHECKED			
DO NOT SCALE DRAWING				TESTED			
FINISH				SCALE			
SIMILAR TO				SHEET			
1				3			
2				4			

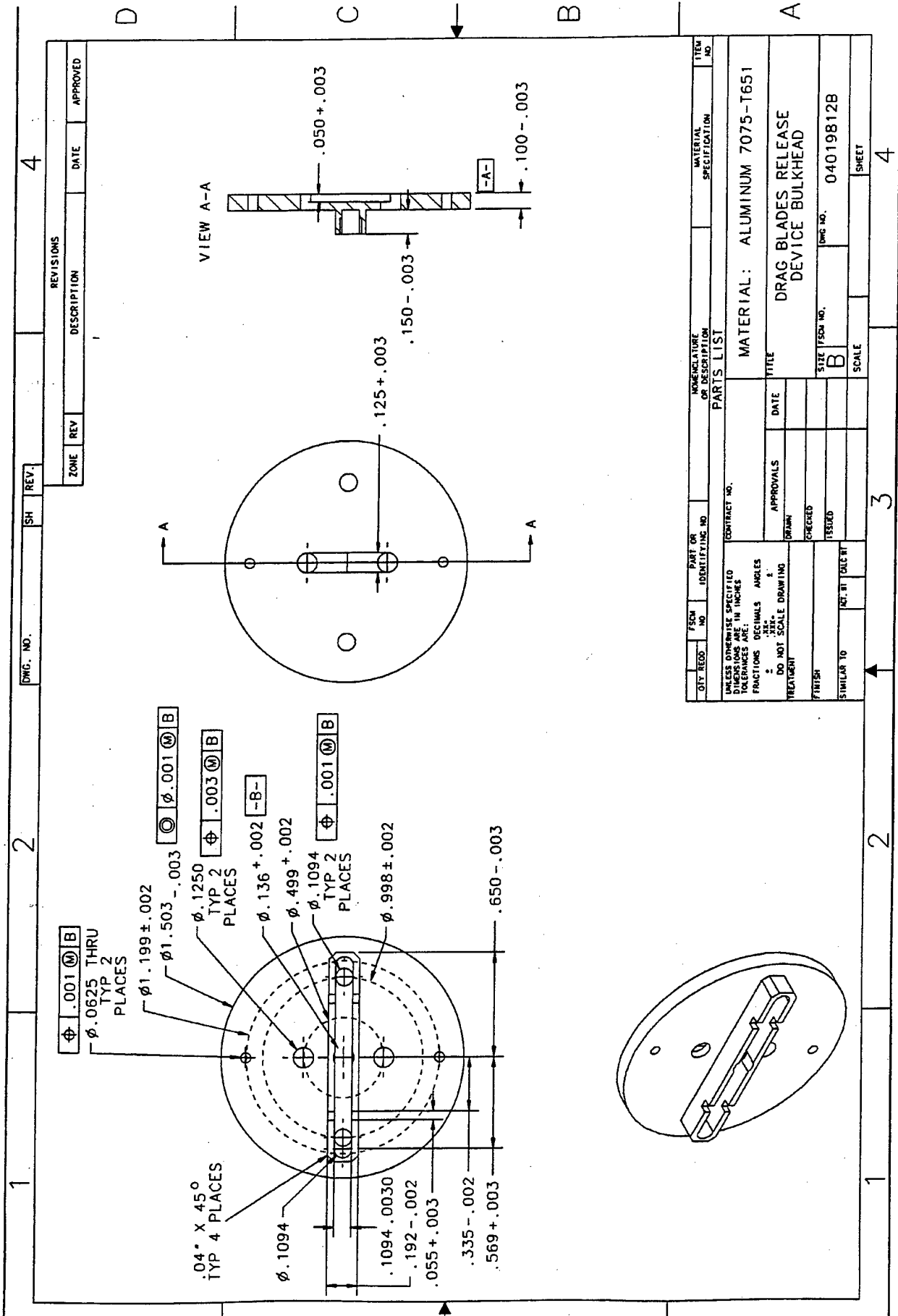

DWG. NO.		SH	REV.	4	
REVISIONS		DESCRIPTION	DATE	APPROVED	
ZONE	REV				

QTY	RECD	FSCN NO	PART OR IDENTIFYING NO	INVENTORY OR IDENTIFYING NO	MATERIAL SPECIFICATION	ITEM NO
PARTS LIST						
MATERIAL: ALUMINUM 7075-T651						
TITLE						
DRAG BLADES RELEASE DEVICE BULKHEAD						
CONTRACT NO.						
APPROVALS						
DATE						
DRAWN						
CHECKED						
TESTED						
FINISH						
SIMILAR TO						
QTY. BY						
SCALE						
SHEET						

DWG. NO.		SH	REV.
REVISIONS			
ZONE	REV	DESCRIPTION	DATE
			APPROVED

NEEDED:
 1/16 - "LONG DOWEL PINS
 2 PER ASSEMBLY
 DEPLOYMENT DEVICE ALIGNMENT PINS

SLIDER ALIGNMENT PIN
 1 PER ASSEMBLY

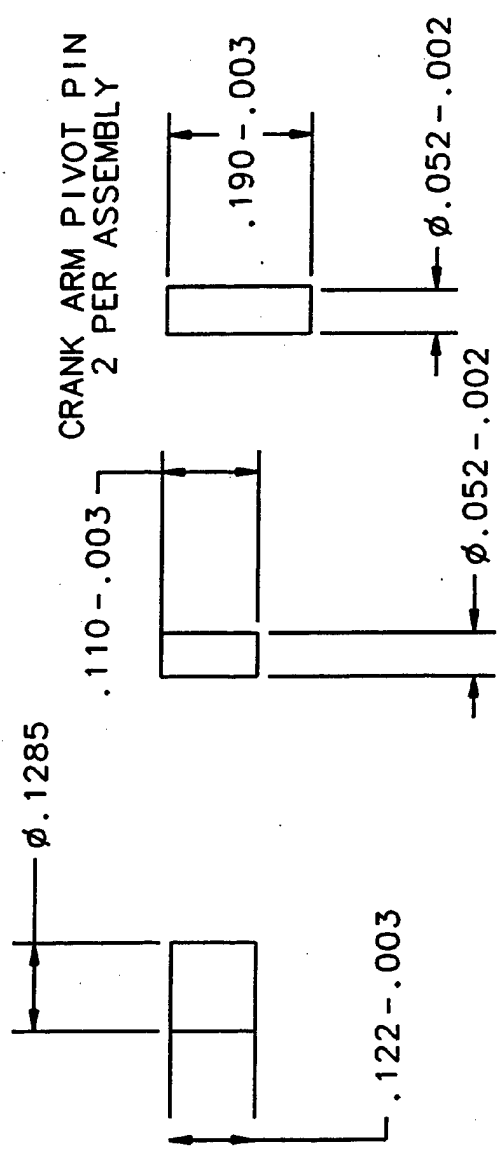

CRANK ARM CONNECTOR PIN
 4 PER ASSEMBLY

QTY RECD	FSCM NO	PART OR IDENTIFYING NO	NOMENCLATURE OR DESCRIPTION	MATERIAL SPECIFICATION	ITEM NO
PARTS LIST					
UNLESS OTHERWISE SPECIFIED DIMENSIONS ARE IN INCHES TOLERANCES ARE: FRACTIONS DECIMALS ANGLES - .XX- .XXX- ± DO NOT SCALE DRAWING			CONTRACT NO.		
TREATMENT			APPROVALS	DATE	TITLE
FINISH			DRAWN		ASSORTED PINS
SIMILAR TO			CHECKED		
NET WT			ISSUED		
CALC WT			SCALE		SIZE FSCM NO.
			A		DWG NO. 04019813
			SHEET		

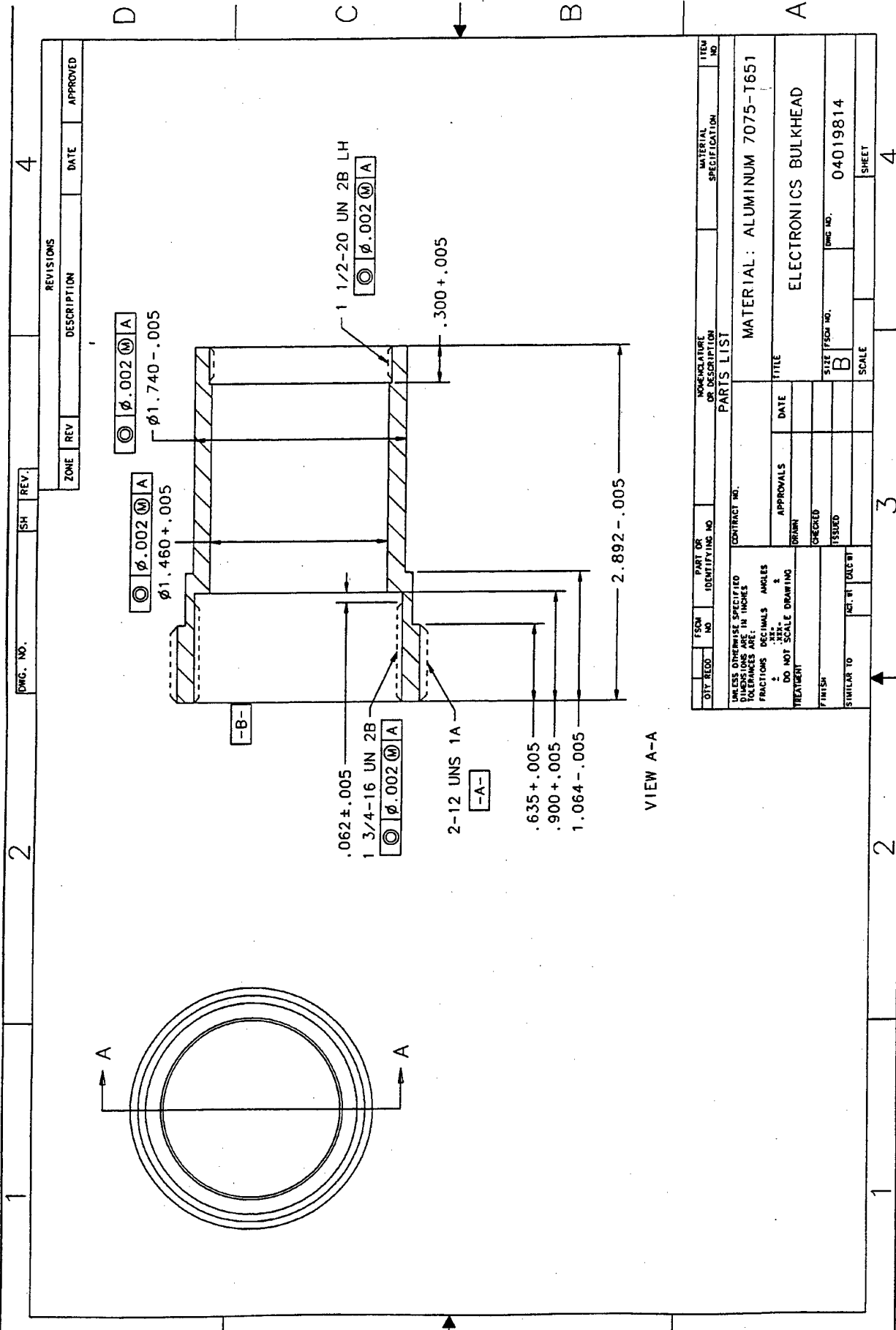

VIEW A-A

DWG. NO.		SH		REV.		REVISONS	
2		4		4		4	
ZONE	REV	DESCRIPTION	DATE	APPROVED			

DWG. NO.	REV. NO.	DATE	SHEET
2	4		4

DITY RECD		FSOM NO		PART OR IDENTIFYING NO		INVENTORY OR DESCRIPTION		MATERIAL SPECIFICATION		ITEM NO	
						PARTS LIST		MATERIAL: ALUMINUM 7075-T651			
UNLESS OTHERWISE SPECIFIED DIMENSIONS ARE IN INCHES TOLERANCES ARE:		CONTRACT NO.		APPROVALS		DATE		TITLE			
FRACTIONS DECIMALS ANGLES				DATE				ELECTRONICS BULKHEAD			
.XXX .XXX .XXX				CHECKED		ISSUED		SCALE		B	
DO NOT SCALE DRAWING TREATMENT				FINISH		SIMILAR TO		SIZE		FSOM NO.	
						REV. DATE		04019814		04019814	
								SCALE		SHEET	
								3		4	

DWG. NO.		SH		REV.	
REVISIONS			APPROVED		
ZONE	REV	DESCRIPTION	DATE		

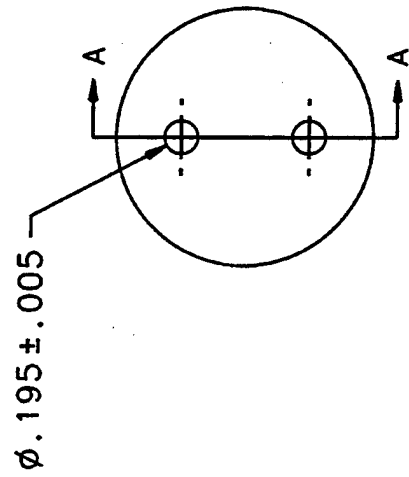
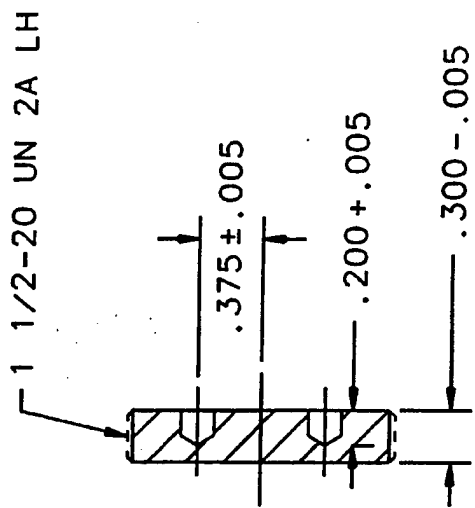

VIEW A-A

QTY RECD	FSCM NO	PART OR IDENTIFYING NO	INDEMNITY OR DESCRIPTION	MATERIAL SPECIFICATION	ITEM NO
CONTRACT NO.			PARTS LIST		
UNLESS OTHERWISE SPECIFIED DIMENSIONS ARE IN INCHES TOLERANCES ARE:		MATERIAL: ALUMINUM 7075-T651			
FRACTIONS	DECIMALS	ANGLES	TITLE		
±	.XX	±	END CAP		
DO NOT SCALE DRAWING		APPROVALS	DATE	SIZE	FSCM NO.
TREATMENT		DRAWN		A	DWG NO. 04019815
FINISH		CHECKED		SCALE	
SIMILAR TO	ACT. WT	ISSUED		SHEET	

4 3 2 1

REVISIONS			DATE	APPROVED
ZONE	REV	DESCRIPTION		

#42 HOLE TYP 7 PLACES

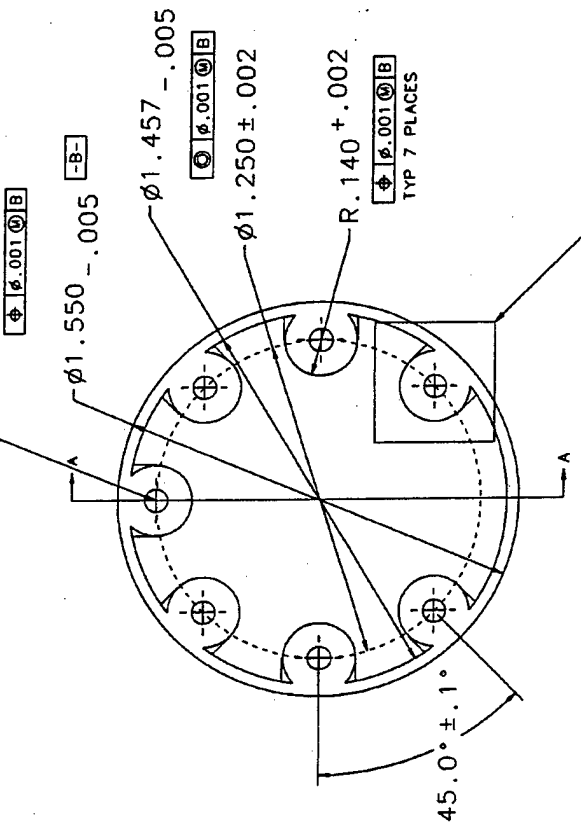

DETAIL B

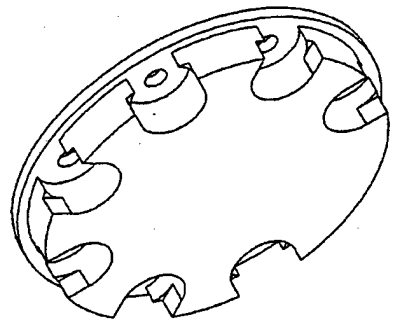
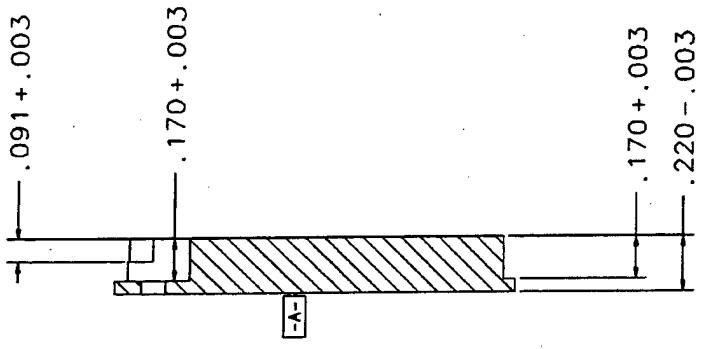
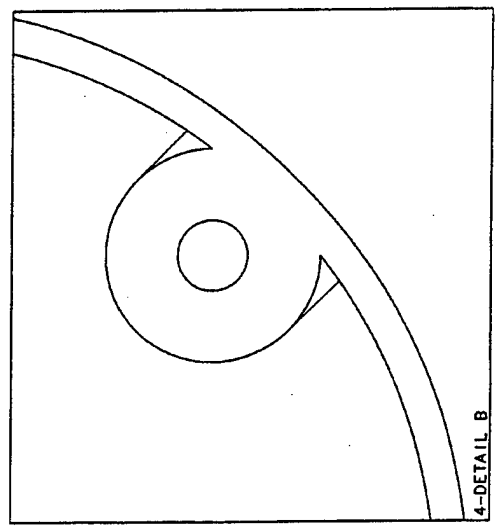

ITEM NO.	ITEM	QUANTITY	DESCRIPTION	UNIT	REVISION NO.
PARTS LIST					
MATERIAL: ULTEM					
INTERNAL POWER CONNECTOR					
DATE: 04/19/81					
DRAWN BY: C					
SCALE: 1					
SHEET: 1					

1	2	3	4	1	2	3	4
Dwg. No.		SH REV.		REVISIONS			
				ZONE	REV	DATE	APPROVED
				1			
D				C			
B				A			
39				3			

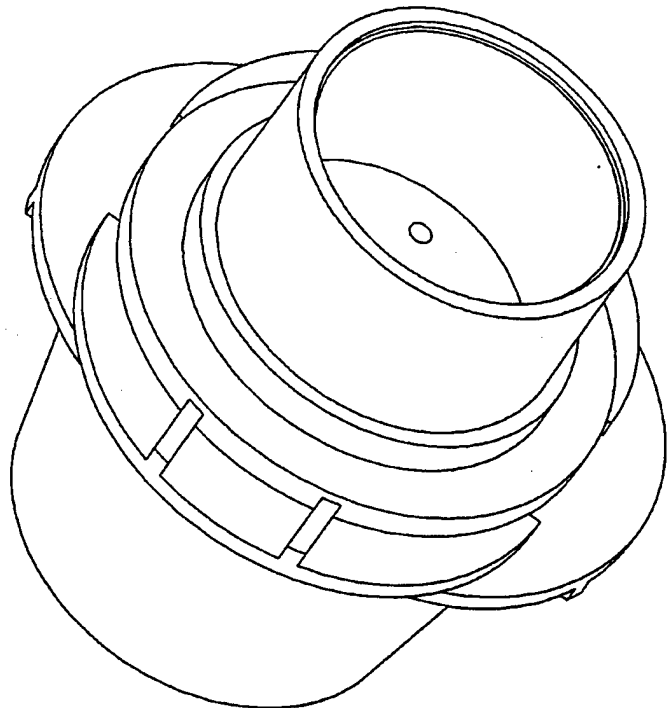
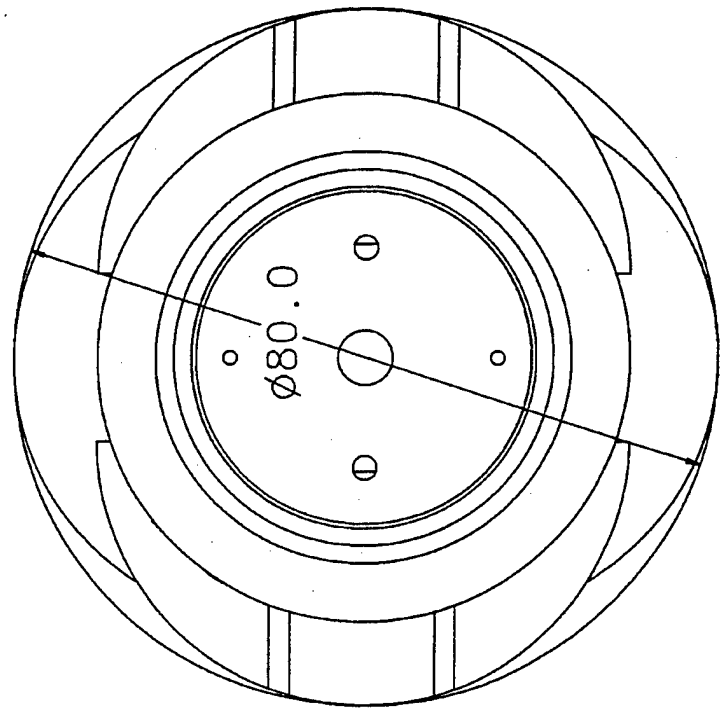

CITY	FSCN NO.	PART OR IDENTIFYING NO.	NOMENCLATURE OR DESCRIPTION	MATERIAL SPECIFICATION	ITEM NO.
PARTS LIST					
UNLESS OTHERWISE SPECIFIED DIMENSIONS ARE IN INCHES FRACTIONS DECIMALS ANGLES			TITLE		
DO NOT SCALE DRAWING			80 mm BLADES ASSEMBLY		
TREATMENT			DRAWN		
FINISH			CHECKED		
SIMILAR TO			TESTED		
REF. BY			SCALE		
			SHEET		
			4019817		

DWG. NO.		SH		REV.	
REVISIONS					
ZONE	REV	DESCRIPTION	DATE	APPROVED	

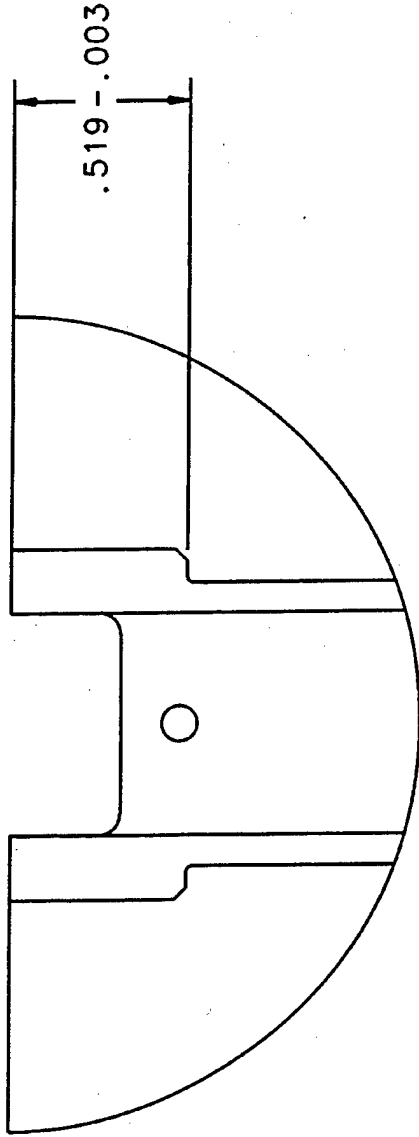

NOTE: ALL DIMENSIONS CONCERNING THE FABRICATION OF THIS
BLADE ARE GOVERNED BY DWG#04019805

QTY	FSQM NO	PART OR IDENTIFYING NO	NOMENCLATURE OR DESCRIPTION	MATERIAL SPECIFICATION	ITEM NO
PARTS LIST					
UNLESS OTHERWISE SPECIFIED DIMENSIONS ARE IN INCHES TOLERANCES ARE:			CONTRACT NO.		
FRACTIONS DECIMALS ANGLES			TITLE		
.			LOWERMOST DRAG BLADE		
DO NOT SCALE DRAWING			80 mm ASSEMBLY		
TREATMENT			APPROVALS		
FINISH			DRAWN		
SIMILAR TO			CHECKED		
ACT. WT			ISSUED		
CALC WT			DATE		
SCALE			DRAWN		
SHEET			CHECKED		
A			ISSUED		
04019818			DATE		
04019818			DRAWN		
04019818			CHECKED		
04019818			ISSUED		
04019818			DATE		

APPENDIX B
PHOTOGRAPHS OF FLIGHT TEST HARDWARE

INTENTIONALLY LEFT BLANK

PHOTOGRAPHS OF FLIGHT TEST HARDWARE

In early January 1997, a D-ring range correction concept with an 80-mm deployment diameter was tested at Wallops Island National Aeronautics and Space Administration (NASA) flight test facility. Four 155-mm M483A1, inert artillery shells were fitted with D-ring range correction devices that deployed the drag plates at specified times in the flights. The devices were instrumented with a timing circuit, a deployment sensor, and telemetry electronics. After being successfully cannon launched, the mechanisms were deployed at either 10- or 20-second intervals, depending on the timing circuit setting (Hollis 1998). This appendix presents photographs of the hardware that was flown for that test.

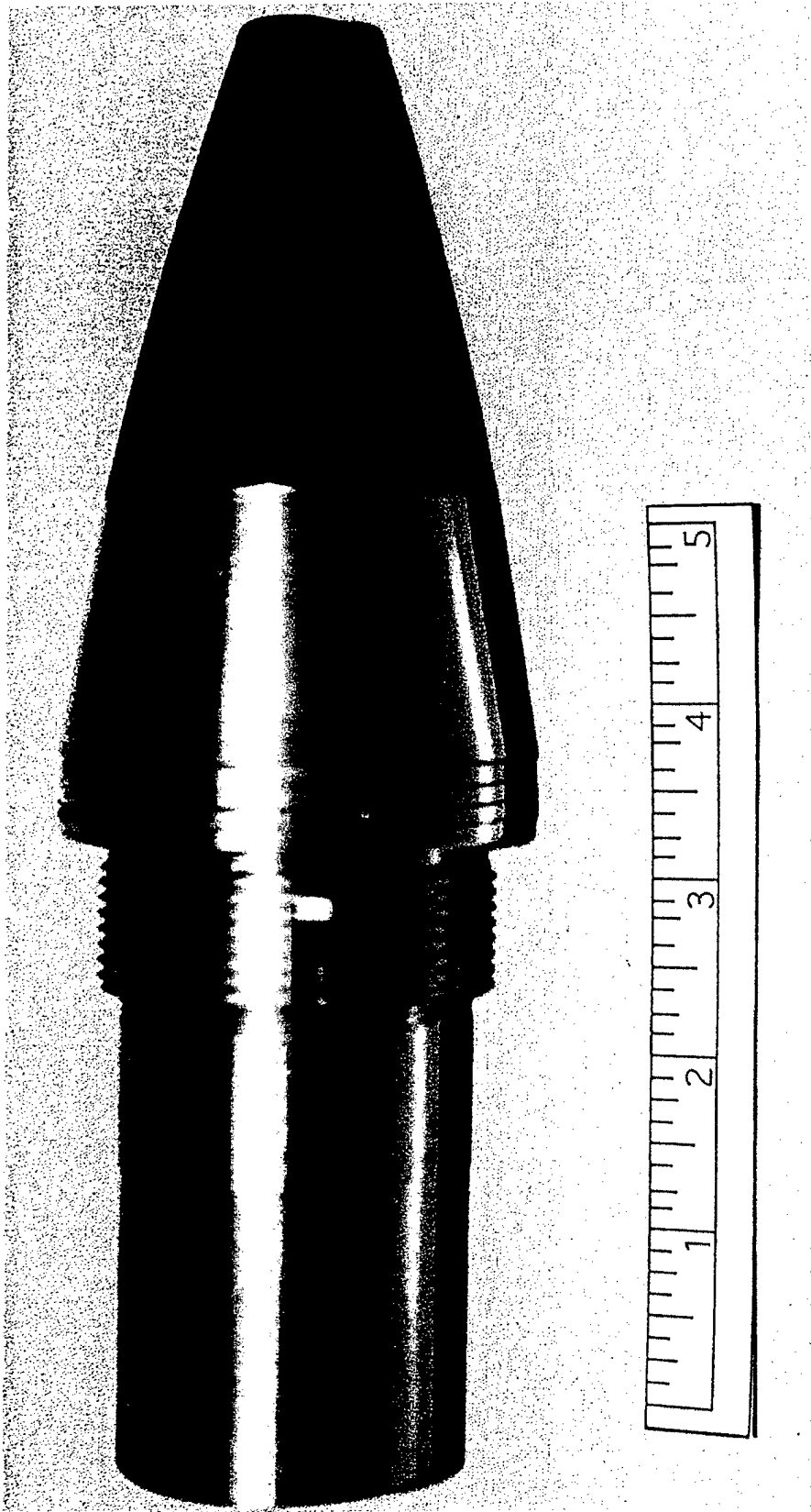

Figure B-1. Assembled D-ring Range Correction Device in the Pre-deployed Configuration.

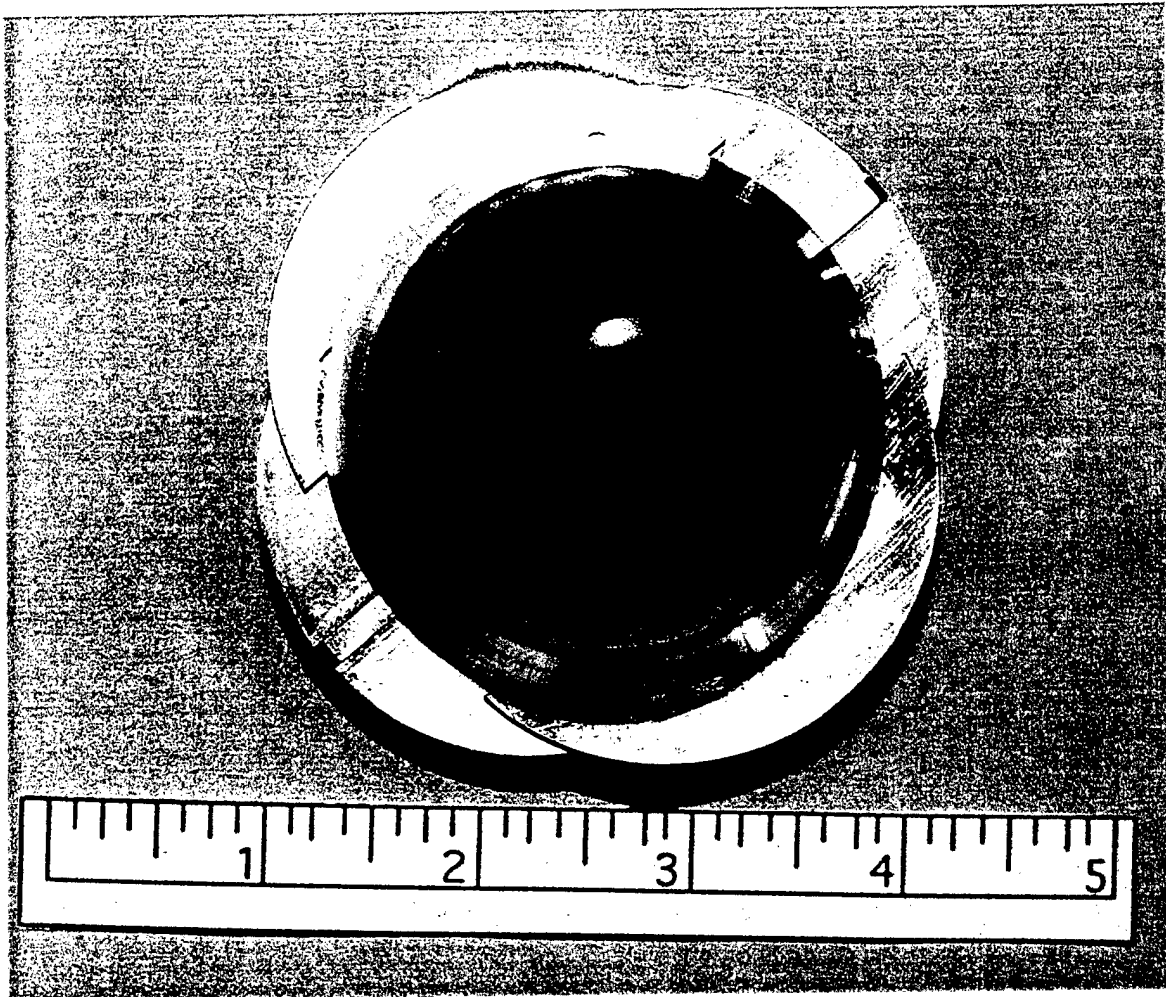

Figure B-2. A Top-down View of the Range Correction Device With the Drag Blades Fully Deployed.

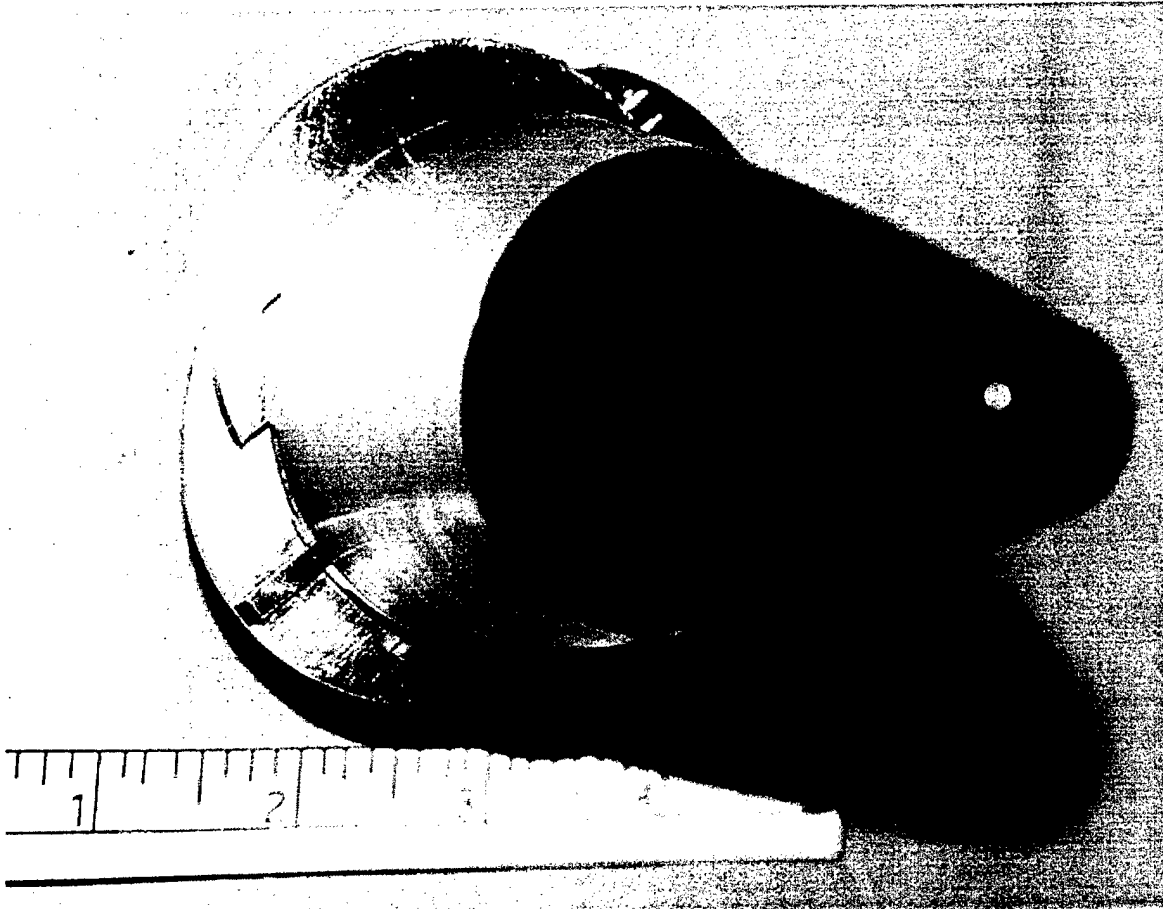

Figure B-3. An Isometric View of the Range Correction Device With the Drag Blades Fully Deployed.

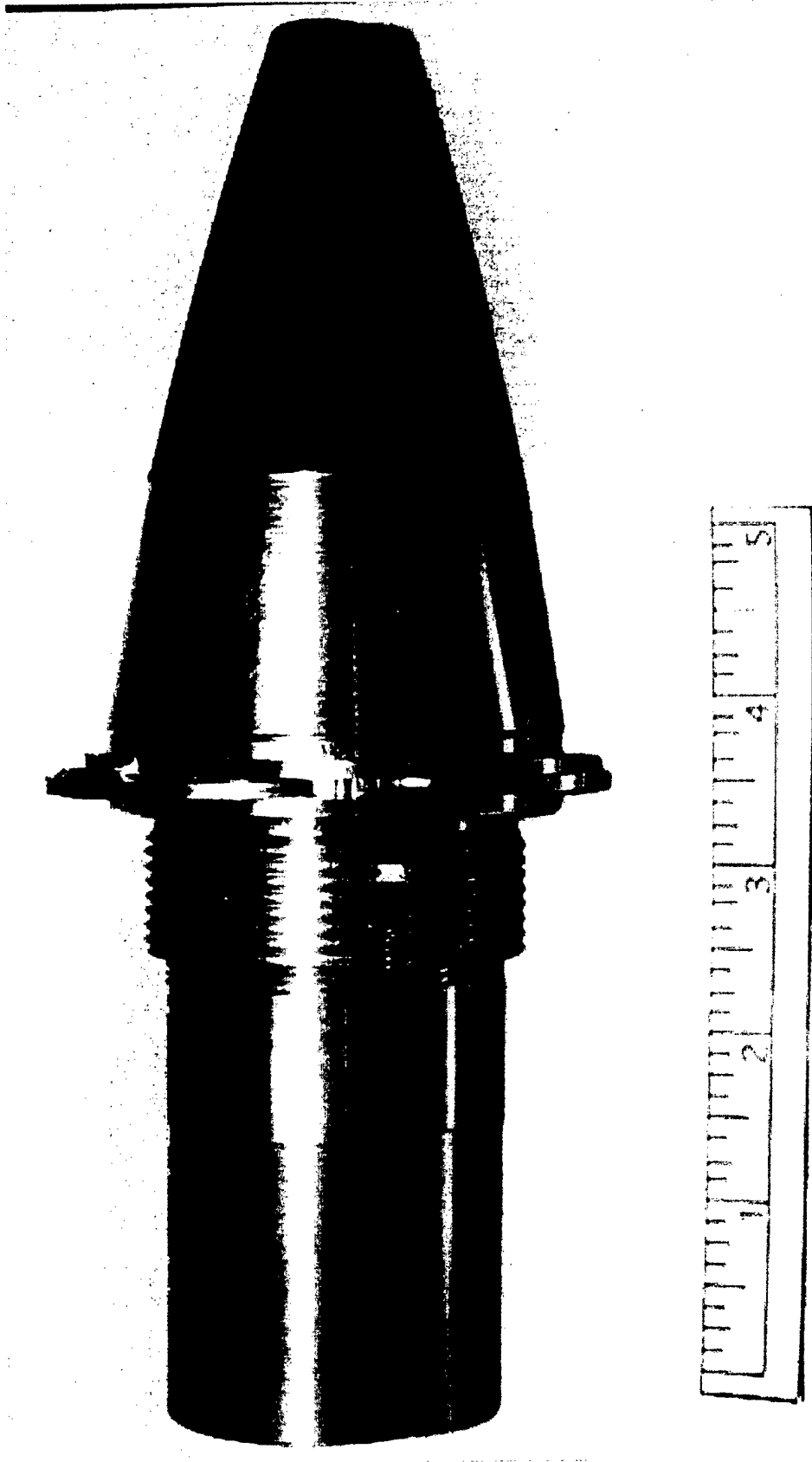

Figure B-4. A Side View of the Range Correction Device With the Drag Blades Fully Deployed.

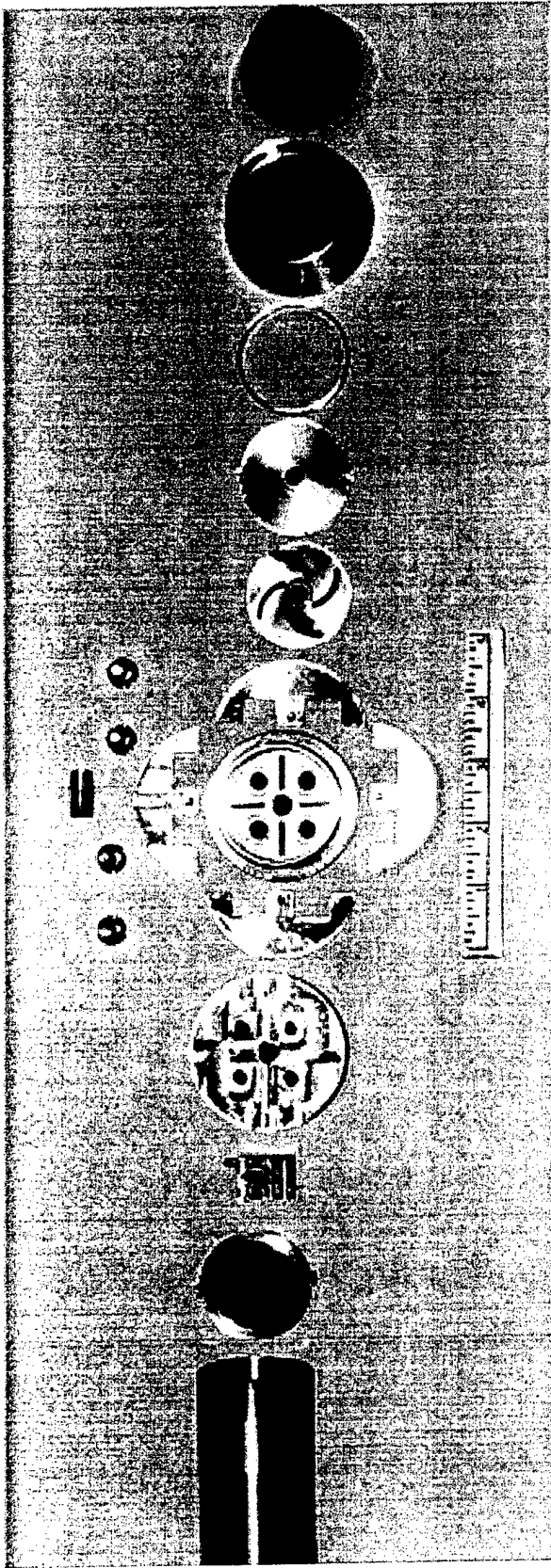

Figure B-5. An Exploded Assembly View of the Range Correction Device.

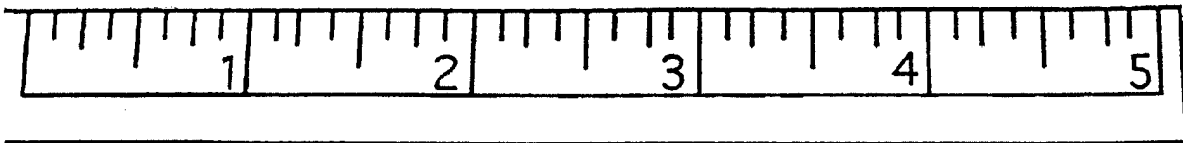
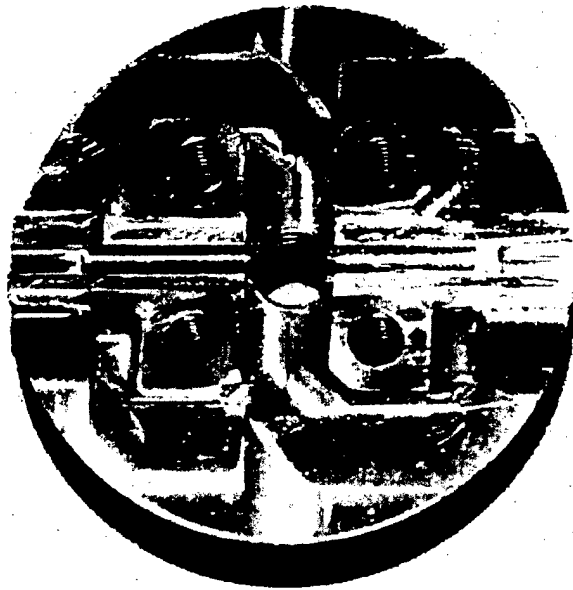

Figure B-6. An Isometric View of the Lower Blade Guide for the Range Correction Device.

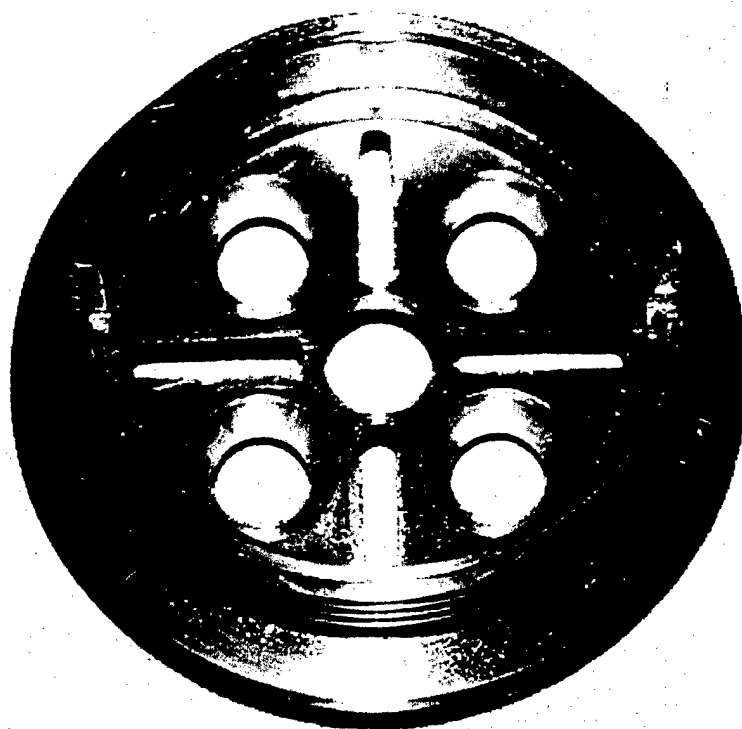

Figure B-7. An Isometric View of the Top of the Cam Plate Housing for the Range Correction Device.

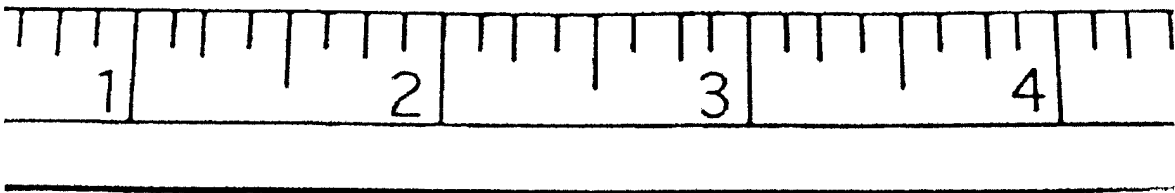

Figure B-8. An Isometric View of the Bottom of the Cam Plate Housing for the Range Correction Device.

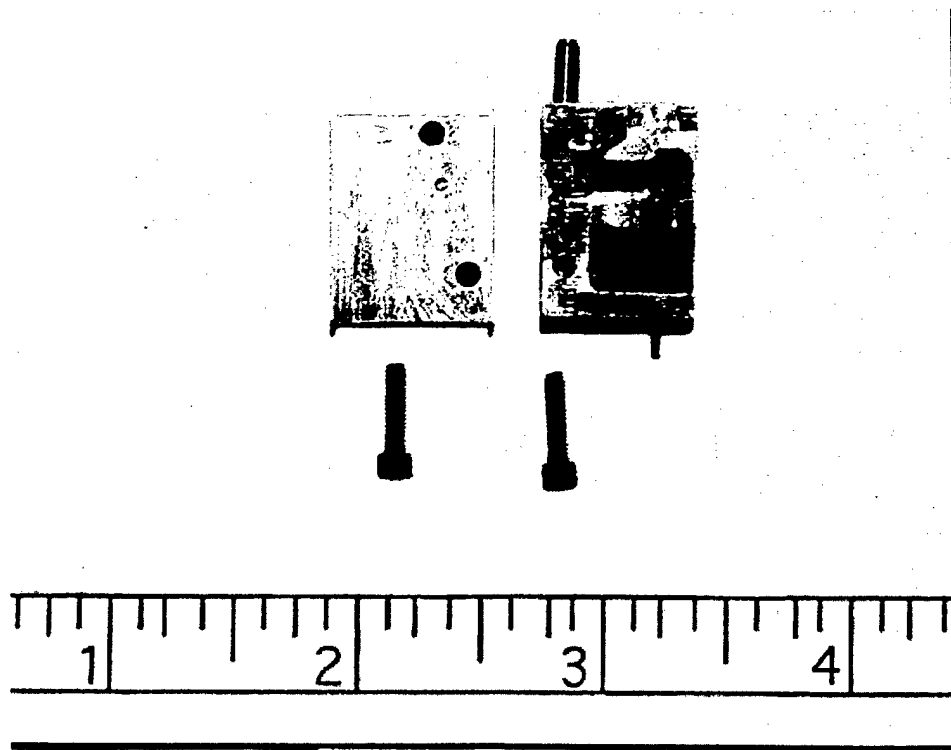

Figure B-9. A Pre-assembly View of the Blade Locking Device That Allowed the Blades to Deploy at the Desired Time.

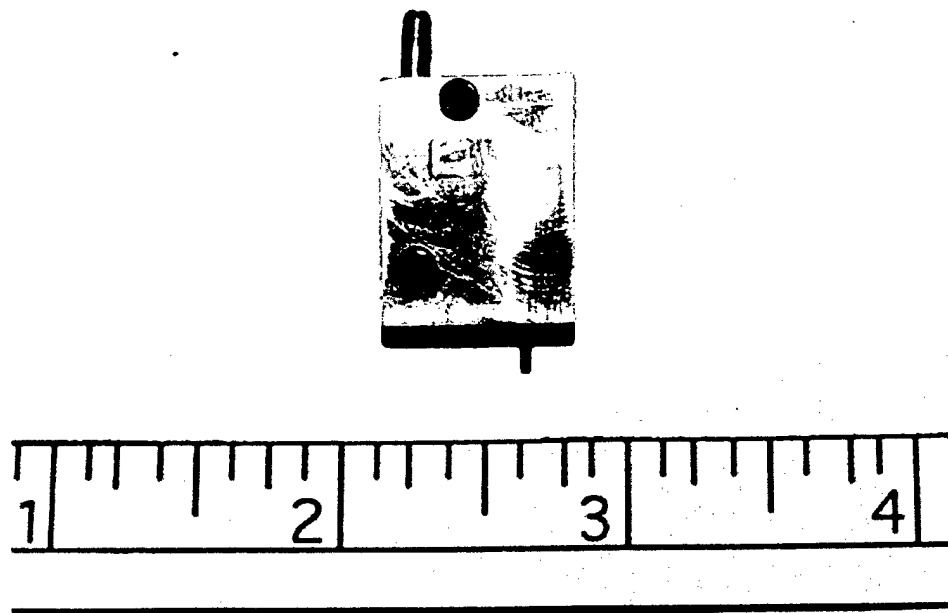

Figure B-10. An Assembled View of the Locking Device for the Range Correction Device.

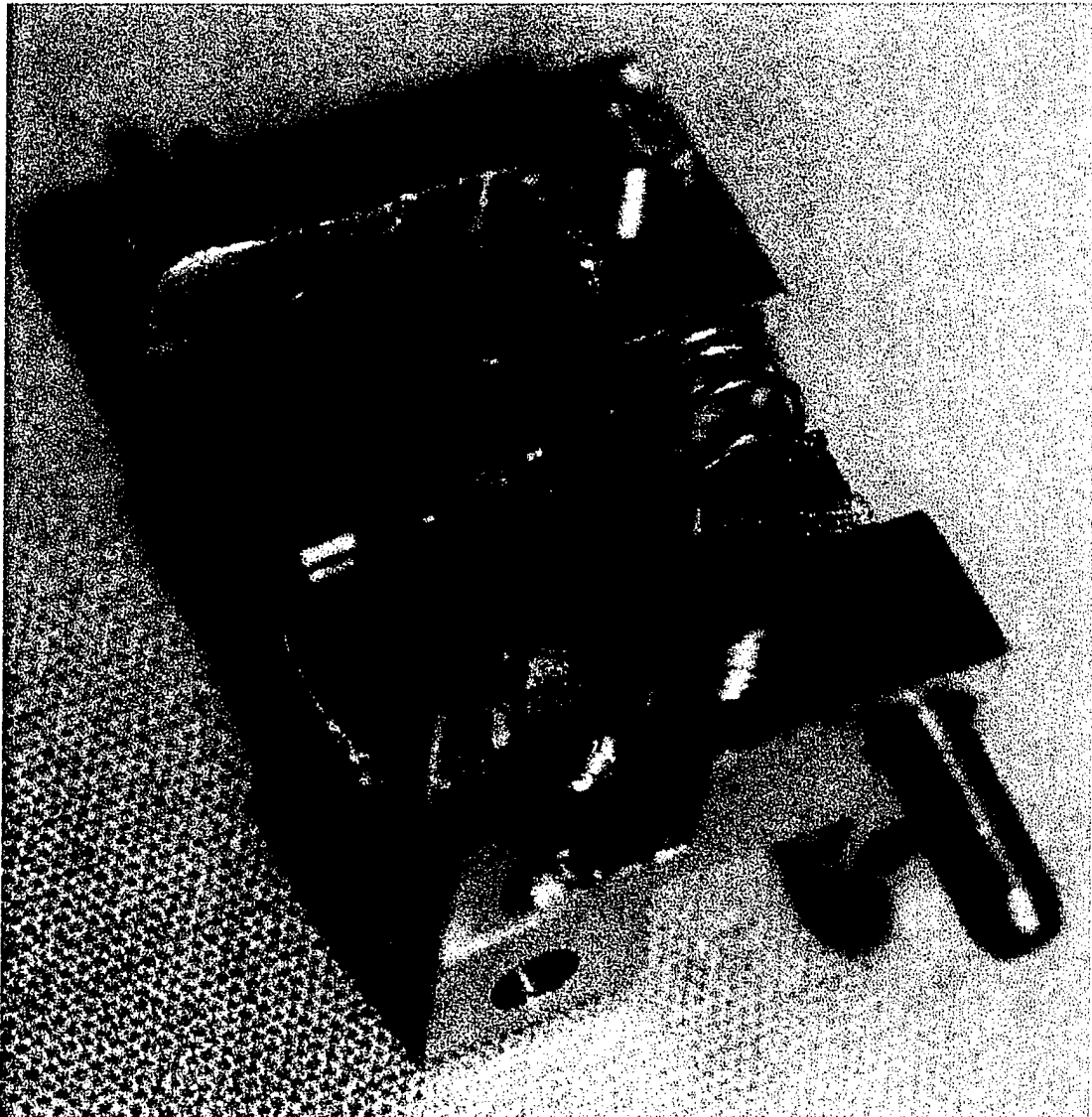

Figure B-11. An Isometric View of the Blade Locking Device Without the Cover.

INTENTIONALLY LEFT BLANK

<u>NO. OF COPIES</u>	<u>ORGANIZATION</u>	<u>NO. OF COPIES</u>	<u>ORGANIZATION</u>
2	ADMINISTRATOR DEFENSE TECHNICAL INFO CENTER ATTN DTIC OCP 8725 JOHN J KINGMAN RD STE 0944 FT BELVOIR VA 22060-6218	1	NAWC/WPNS ATTN CODE 543200E GARY BORGEN BLDG 311 POINT MUGU CA 93042-5000
1	DIRECTOR US ARMY RESEARCH LABORATORY ATTN AMSRL CS AS REC MGMT 2800 POWDER MILL RD ADELPHI MD 20783-1197	1	PRIMEX ATTN JOSEPH BUZZETT 10101 9TH ST NORTH ST PETERSBURG FL 33716
1	DIRECTOR US ARMY RESEARCH LABORATORY ATTN AMSRL CI LL TECH LIB 2800 POWDER MILL RD ADELPHI MD 207830-1197	1	ALLIANT TECHSYSTEMS ATTN MN11-1428 C CANDLAND 600 SECOND ST NE HOPKINS MN 55343-8384
1	DIRECTOR US ARMY RESEARCH LABORATORY ATTN AMSRL DD 2800 POWDER MILL RD ADELPHI MD 20783-1197	1	NATIONS INC ATTN ROBERT CARPENTER 12249 SCIENCE DRIVE ORLANDO FL 32826
1	DIR US AIR FORCE WRIGHT LAB ATTN WL/MNAV GREGG ABATE 101 N EGLIN BLVD SUITE 219 EGLIN AIR FORCE BASE FL 32542-6810	1	STRICOM ATTN STRICOM EL R COLANGELO 12350 RESEARCH PARK ORLANDO FL 32826-3276
3	CDR US ARMY ARDEC ATTN AMSTA AR AET A M AMORUSO AMSTA AR AET C S LONGO AMSTA AR SCF D G ECKSTEIN PICATINNY ARSENAL NJ 07806-5000	2	TACOM ARDEC ATTN MIKE D'ONOFRIO ADELPHI MD 20783-1197
1	AUBURN UNIVERSITY ATTN RONALD BARRETT 211 AEROSPACE ENGINEER ST AUBURN UNIV AL 36849-5338	1	DIRECTOR US ARMY RTTC ATTN STERT TE F TD R T EPPS K WHIGHAM BLDG 7855 REDSTONE ARSENAL AL 35898-8052
1	RICHARD BEATTIE ATTN DRA FT HALSTEAD-SEVENOAKS KENT ENGLAND TN14 7BP	1	TAP/AIRCRAFT INSTRUMENTATION DIV ATTN R FAULSTICH 5.4.2 UNIT 1 47765 RANCH ROAD NAVAL AIR WARFARE CTR AIRCRAFT DIVISION PATUXENT RIVER MD 20670-1469
2	APL ATTN R BENSON D WICKENDEN 11100 JOHNS HOPKINS ROAD LAUREL MD 20723-6099	1	IOA INST FOR DEFENSE ANALYSIS ATTN JOHN FRASIER 1801 N BEAUREGARD ST ALEXANDRIA VA 22311-1772
1	ROBERT BODENSCHATZ 2001 N BEAUREGARD ST SUITE 800 ALEXANDRIA VA 22311	2	COMMANDER NAVAL SURFACE WARFARE CTR ATTN J FRAYSEE D HAGEN 17320 DAHLGREN RD DAHLGREN VA 22448-5150

<u>NO. OF COPIES</u>	<u>ORGANIZATION</u>	<u>NO. OF COPIES</u>	<u>ORGANIZATION</u>
3	ARROW TECH ASSOCIATES INC ATTN W HATHAWAY JOHN WHYTE R WHYTE 1233 SHELBOURNE RD STE D8 SOUTH BURLINGTON VT 05403	1	JACK THALHEIMER 1911 NORTH FT MEYER DR SUITE 800 ARLINGTON VA 22209
1	COMMANDER USA YUMA PROV GRND ATTN STEPY RS EL A HOOPER YUMA AZ 85365-9110	1	CDR US ARMY ARDEC ATTN WILLIAM VOGT BLDG 171A PICATINNY ARSENAL NJ 07806-5000 <u>ABERDEEN PROVING GROUND</u>
2	CDR US ARMY ARDEC ATTN AMSTA FSP A V ILLARDI R SICIGNANO PICATINNY ARSENAL NJ 07806-5000	2	DIRECTOR US ARMY RESEARCH LABORATORY ATTN AMSRL CI LP (TECH LIB) BLDG 305 APG AA
1	IMI INC ATTN THOR JUNEAU 2140 SHATTUCH AVE BERKELEY CA 94703	1	US ARMY ATC ATTN STEAC TC E K MCMULLEN BLDG 400
1	DIRECTOR US ARMY RSRCH LAB ATTN AMSRL SS SM A LADAS 2800 POWDER MILL RD ADELPHI MD 20783-1145	1	DIR USARL ATTN AMSRL WM B A W HORST JR BLDG 4600
1	ANALOG DEVICES ATTN ROBERT MEISENHELDER 804 WOBURN ST WILMINGTON MA 01887-3462	15	DIR USARL ATTN AMSRL WM BA F BRANDON T BROWN L BURKE J CONDON W D'AMICO B DAVIS T HARKINS D HEPNER M HOLLIS (5 CYS) V LEITZKE A THOMPSON BLDG 4600
1	CDR US ARMY ARDEC ATTN FUZE DIVISION F OLIVER PICATINNY ARSENAL NJ 07806-5000	2	DIR USARL ATTN AMSRL WM BB H ROGERS R VON WAHLDE BLDG 1121
1	DAVID PAREKH 7220 RICHARDSON RD SMYRNA GA 30080	1	DIR USARL ATTN AMSRL WM BB T VONG BLDG 1120A
1	DARPA ATTN ALBERT PISANO 3701 N FAIRFAX DRIVE ARLINGTON VA 22203-1714	4	DIR USARL ATTN AMSRL WM BC B GUIDOS P PLOSTINS D LYONS S WILKERSON BLDG 390
1	ANALOG DEVICES ATTN ROBERT SULOUFF 21 OSBORN STREET CAMBRIDGE MA 02139-3556	1	DIR USARL ATTN AMSRL WM BD B FORCH BLDG 4600
1	RALPH TADDEO 10101 9TH STREET NORTH ST PETERSBURG FL 33716		

NO. OF
COPIES ORGANIZATION

- 1 DIR USARL
 ATTN AMSRL WB BF
 J LACETERA
 BLDG 120
- 1 DIR USARL
 ATTN AMSRL WM BR
 C SHOEMAKER
 BLDG 1121
- 2 DIR USARL
 ATTN AMSRL WM MB
 B BURNS L BURTON
 BLDG 4600

ABSTRACT ONLY

- 1 DIRECTOR
 US ARMY RESEARCH LABORATORY
 ATTN AMSRL CS EA TP TECH PUB BR
 2800 POWDER MILL RD
 ADELPHI MD 20783-1197

INTENTIONALLY LEFT BLANK

REPORT DOCUMENTATION PAGE

Form Approved
OMB No. 0704-0188

Public reporting burden for this collection of information is estimated to average 1 hour per response, including the time for reviewing instructions, searching existing data sources, gathering and maintaining the data needed, and completing and reviewing the collection of information. Send comments regarding this burden estimate or any other aspect of this collection of information, including suggestions for reducing this burden, to Washington Headquarters Services, Directorate for Information Operations and Reports, 1215 Jefferson Davis Highway, Suite 1204, Arlington, VA 22202-4302, and to the Office of Management and Budget, Paperwork Reduction Project (0704-0188), Washington, DC 20503.

1. AGENCY USE ONLY (Leave blank)		2. REPORT DATE December 1999	3. REPORT TYPE AND DATES COVERED Final	
4. TITLE AND SUBTITLE Design and Analysis of a Fuze-Configurable Range Correction Device for an Artillery Projectile			5. FUNDING NUMBERS PR: 1L162618AH80	
6. AUTHOR(S) Hollis, M.S.L.; Brandon, F.J. (both of ARL)				
7. PERFORMING ORGANIZATION NAME(S) AND ADDRESS(ES) U.S. Army Research Laboratory Weapons & Materials Research Directorate Aberdeen Proving Ground, MD 21010-5066			8. PERFORMING ORGANIZATION REPORT NUMBER	
9. SPONSORING/MONITORING AGENCY NAME(S) AND ADDRESS(ES) U.S. Army Research Laboratory Weapons & Materials Research Directorate Aberdeen Proving Ground, MD 21010-5066			10. SPONSORING/MONITORING AGENCY REPORT NUMBER ARL-TR-2074	
11. SUPPLEMENTARY NOTES				
12a. DISTRIBUTION/AVAILABILITY STATEMENT Approved for public release; distribution is unlimited.			12b. DISTRIBUTION CODE	
13. ABSTRACT (Maximum 200 words) <p>The primary purpose of the low cost competent munitions (LCCM) program was to improve the effectiveness of indirect fire support from cannon artillery (D'Amico 1996). With the advances in microelectronics, sensor technology, and packaging design, the reality of a range correction device for artillery is conceivable. One of the main objectives of the range correction device concept was to contain all the mechanical and electrical components within a fuze-like envelope, while maintaining certain constraints that would allow the fuze to fit into a variety of artillery shells used by North Atlantic Treaty Organization (NATO) countries. Another objective of the range correction device concept was to avoid any changes within the ogive of any of the projectiles in the existing stockpile.</p> <p>This report is a culmination of many design iterations, numerical analyses, shock tests, and actual cannon launchings. Most of the design iterations and numerical analyses are not mentioned in this report simply because they were stepping stones that led to the final design. Structural analyses indicated that the overall prototype design was durable enough to withstand the most severe artillery cannon launching available today. The design should be capable of withstanding a 15,000 g inertial set-back load with 150,000 rad/s² of angular acceleration. In addition, the design should be capable of deploying while the projectile has velocity of 650 m/s and is spinning at 250 cycles per second. The next step would be to fabricate and test the design in order to truly verify the integrity of the structure and to determine the overall effect of the deployed drag blades on the range of flight.</p>				
14. SUBJECT TERMS analysis projectile fuze configurable range correction			15. NUMBER OF PAGES 70	
			16. PRICE CODE	
17. SECURITY CLASSIFICATION OF REPORT Unclassified	18. SECURITY CLASSIFICATION OF THIS PAGE Unclassified	19. SECURITY CLASSIFICATION OF ABSTRACT Unclassified	20. LIMITATION OF ABSTRACT	