



Munitions Survivability Technology: A Comparison of the Effectiveness of Two Different Blanket Designs for Protecting Against an Indirect Fragment Threat

by Vincent M. Boyle, Alfred L. Bines, and William B. Sunderland

ARL-TR-2122

Nov 1999

20000207 130

Approved for public release; distribution is unlimited.

The findings in this report are not to be construed as an official Department of the Army position unless so designated by other authorized documents.

Citation of manufacturer's or trade names does not constitute an official endorsement or approval of the use thereof.

Destroy this report when it is no longer needed. Do not return it to the originator.

Army Research Laboratory

Aberdeen Proving Ground, MD 21005-5066

ARL-TR-2122

November 1999

Munitions Survivability Technology: A Comparison of the Effectiveness of Two Different Blanket Designs for Protecting Against an Indirect Fragment Threat

Vincent M. Boyle, Alfred L. Bines, and William B. Sunderland
Weapons and Materials Research Directorate, ARL

Abstract

This report describes the results of tests comparing the ballistic effectiveness of two types of Kevlar blanket when impacted by a steel fragment weighing 0.66 lb and having a velocity of 450 ft/s. This fragment, a right circular cylinder, was used to simulate the weight and velocity of a fragment that could be generated when a stack of barricaded M107 munitions detonates and throws fragments upward; when the fragment returns to the ground, the terminal velocity for this weight and shape was calculated to be 450 ft/s. Adjacent barricaded stacks of munitions could be impacted (indirect fragment impact) and react explosively, especially if the fragment is hot. However, if a ballistic blanket covered the ammunition stack, the fragment could be prevented from reaching the munitions. The tests reported here were done using room-temperature fragments. A small gas gun was designed and built to launch the fragments to the required velocity; all fragments impacted the blanket head on. Test results indicate that, for the same areal density, a 3,000-denier tight-weave blanket is more effective for stopping fragments than a 1,500-denier loose-weave material. Also, an eight-layer, 3,000-denier blanket having an areal density of 0.76 lb/ft² prevented fragment penetration.

Table of Contents

	<u>Page</u>
List of Figures	v
List of Tables	vii
1. Introduction	1
2. Experimental Details	1
2.1 Fragment Description	1
2.2 Launch System	2
2.3 Blanket Clamp	5
2.4 Test Layout	6
3. Blanket Samples	6
4. Test Results	8
5. Discussion	8
6. Conclusions	13
Distribution List	15
Report Documentation Page	19

INTENTIONALLY LEFT BLANK.

List of Figures

<u>Figure</u>		<u>Page</u>
1.	Breech Chamber Design.....	3
2.	Diaphragm Holder Design	4
3.	Fragment Launch Package	4
4.	Blanket Clamp.....	5
5.	Test Layout.....	6
6.	Fragment Recovery Depth in Packed Rags vs. Areal Density of Blanket.....	11
7.	Number of Layers Penetrated by the Fragment vs. Areal Density of Blanket.....	11
8.	A Comparison of Fragment Penetration Into Blankets With and Without a Wood Back Panel	12

INTENTIONALLY LEFT BLANK.

List of Tables

<u>Table</u>		<u>Page</u>
1.	Ballistic Blanket Samples.....	7
2.	Test Results	9

INTENTIONALLY LEFT BLANK.

1. Introduction

When large quantities of ammunition are stored outdoors the explosion of one stack can lead to the explosion of adjacent stacks by various mechanisms such as direct fragment impact, blast pressure, rapid deformation, and burning due to fire propagation. In order to prevent most of these mechanisms the individual stacks of ammunition can be separated by either large distances or barriers such as earth walls that will attenuate the initial explosion and prevent direct fragment impact. However, even when stacks of munitions are separated by sufficient distance or barricades to prevent direct propagation of explosion, propagation can still occur from stack to stack by indirect means and hot fragments, firebrands, and burning propellant from the initial explosion can be thrown upward and descend onto neighboring stacks of ammunition. If the neighboring stacks contain easily ignitable material such as wooden ammunition crates, propellant, or combustible cartridge cases, then a massive fire and subsequent explosion are likely. This process can repeat itself many times, destroying large stores of munitions in the course of hours or even days. In order to protect against these indirect mechanisms, a heat-blocking blanket with ballistic protection can be used to cover the ammunition stack. In this report, the ballistic properties of two different blankets are compared, when impacted by a 0.66-lb steel fragment. The U.S. Army Research Laboratory (ARL) performed this work for the U.S. Army Defense Ammunition Logistics (Ammolog) Activity.

2. Experimental Details

2.1 Fragment Description. The fragment size was selected by reviewing the results of three separate tests that had been done previously, in which two Composition B (Comp B)-loaded M107 155-mm rounds were simultaneously nose-detonated. The rounds were positioned side by side, upright, and 0.79 in apart on a wooden table. The interaction between the expanding cases produced long strips of hot fragments. The heaviest recovered fragment from these three tests was a strip weighing approximately 0.66 lb. The strip had an irregular shape and tended to be narrower at the ends and thicker near the middle; it was 6.5 in long. For our

tests, we made a more regular fragment by assuming an average length-to-diameter ratio of 10 and calculating the dimensions for a cylindrical steel fragment weighing 0.66 lb. These calculations gave a length of 6.70 in and a diameter of 0.67 in.

When a fragment is ejected upward from an exploding ammunition stack, it will be decelerated by the force of gravity until its vertical velocity is reduced to zero. When the fragment falls back toward earth, the maximum velocity it can reach is its terminal velocity, V . The terminal velocity, assuming that the fragment presented area is a minimum (head-on impact), can be calculated as follows:

$$V = (2 ma/Dsp)^{1/2},$$

where

fragment mass, m , = 0.66 lb;

gravitational acceleration, a , = 32 ft/s²;

drag coefficient of air, D , = 1.0;

density of air, ρ , = 0.075 lb/ft³; and

fragment presented area, s , = 0.00244 ft².

This calculation gives a terminal velocity of 480 ft/s.

2.2 Launch System. A compressed gas gun, having a 1-in smooth bore 10 ft long, was used to accelerate our steel fragment to the required velocities. For our tests, a gun breech and a pressure burst diaphragm were designed to enable us to get the desired fragment velocities. The pressure burst diaphragm was inserted between the pressurized breech and the fragment, which

was seated in the bore of the barrel. The pressure in the breech and the thickness of the diaphragm could be varied to obtain a range of fragment velocities. Figures 1 and 2 show the breech and diaphragm holder designs. Both were made using untempered 4140 steel. The taper of the diaphragm plug was designed to fit snugly into the tapered section of the gun chamber to provide a seal for the high-pressure breech gas. To accelerate the cylindrical fragment and to keep it positioned symmetrically in the gun bore, a fragment launch package was designed as shown in Figure 3. The polypropolux base plug and a low-density (2.2 lb/ft^3) polyethylene sleeve fit snugly in the bore of the gun and centered the fragment. The pusher plate consisted of polypropolux for strength and a polyethylene surround that served as a gas seal. The fragment was mild steel. We did some preliminary tests in order to determine the breech pressure and the diaphragm thickness required to obtain suitable fragment velocities. A breech pressure of approximately 1,000 psi and a polyethylene diaphragm thickness of 0.090 in gave fragment velocities of approximately 430 ft/s. This combination was used for all our tests.

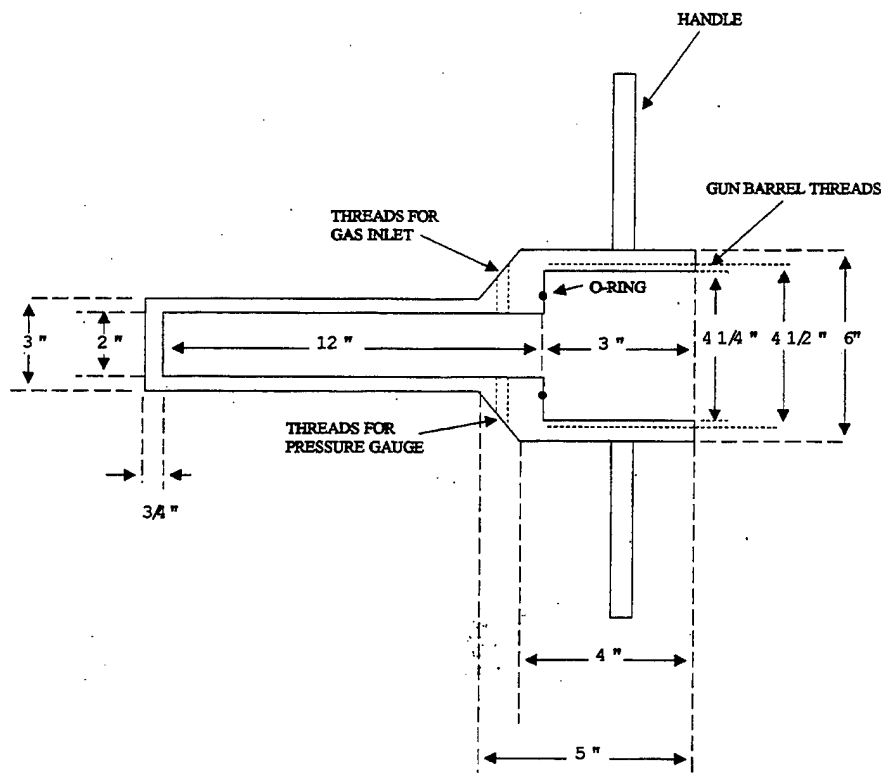

Figure 1. Breech Chamber Design.

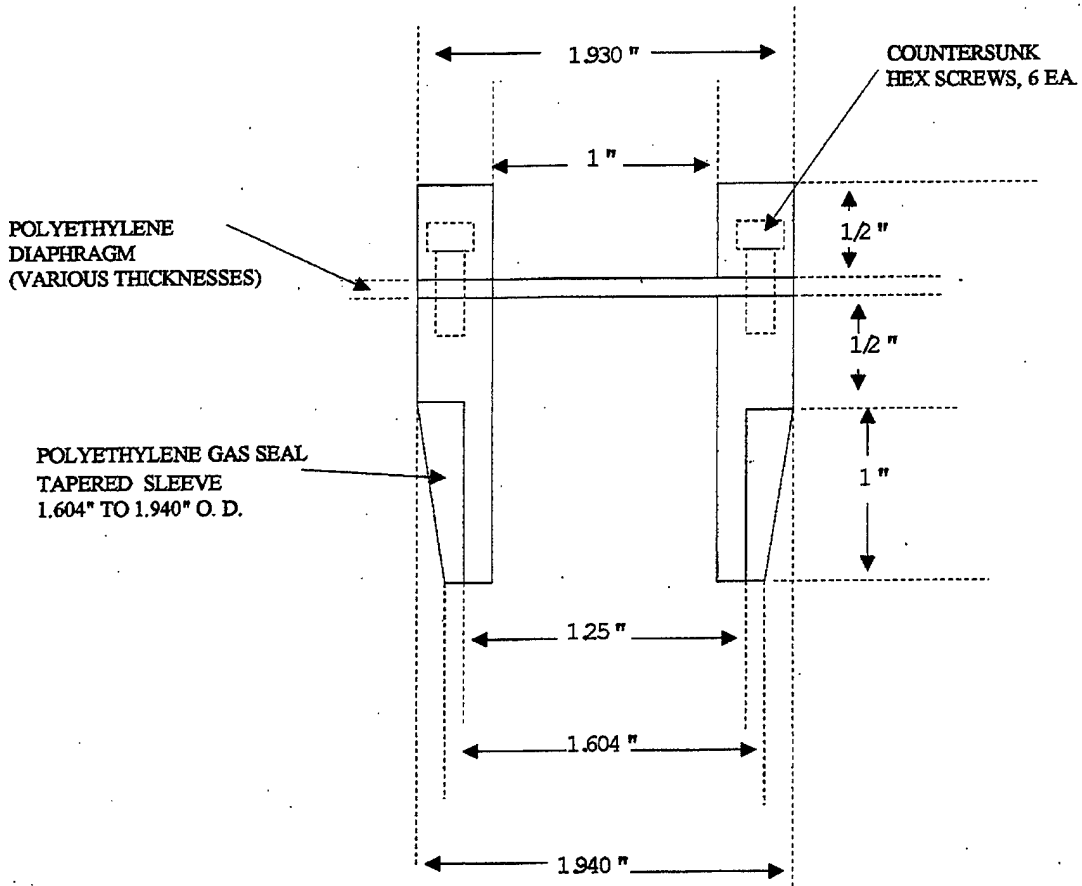

Figure 2. Diaphragm Holder Design.

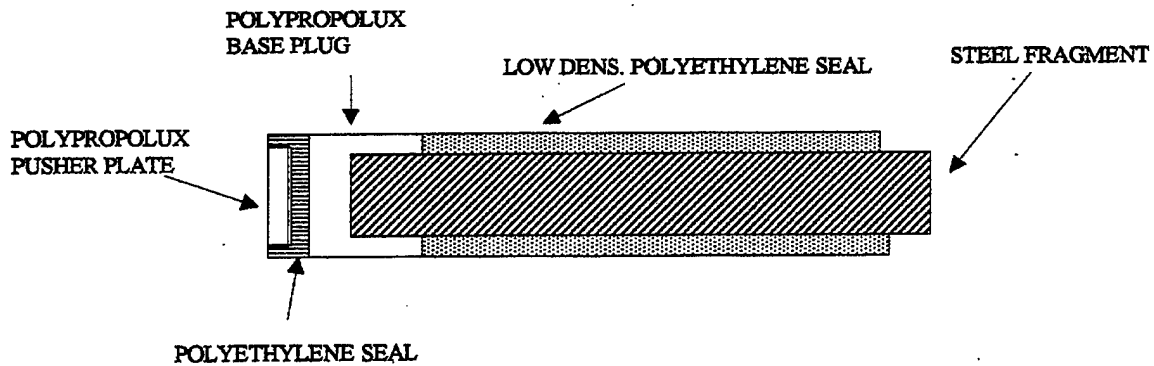

Figure 3. Fragment Launch Package.

2.3 Blanket Clamp. Two 1-in-thick aluminum (Al) frames were used as clamps to hold the blanket samples in place during our tests. Figure 4 shows the clamping arrangement. Large C-clamps (4 in and 6 in) were hand-tightened around the frames. An effort was made to tighten the clamps firmly and uniformly for each test. The edges of the frames were chamfered to remove any irregularities that might concentrate stress; the inside corners of the frames had a 1/2-in radius of curvature. The frame dimensions were 16 in \times 16 in outside and 12 in \times 12 in inside; this provided a 2-in-wide border clamped around the blanket. The blanket samples were either 24 in \times 24 in or 26 in \times 26 in. Several fragment aim points are indicated because we were able to use the same blanket sample for as many as three tests. The minimum distance between aim points was 4 in. In some tests, the blanket was backed by a 3/4-in-thick pinewood panel; the blanket and the panel were in contact and clamped together.

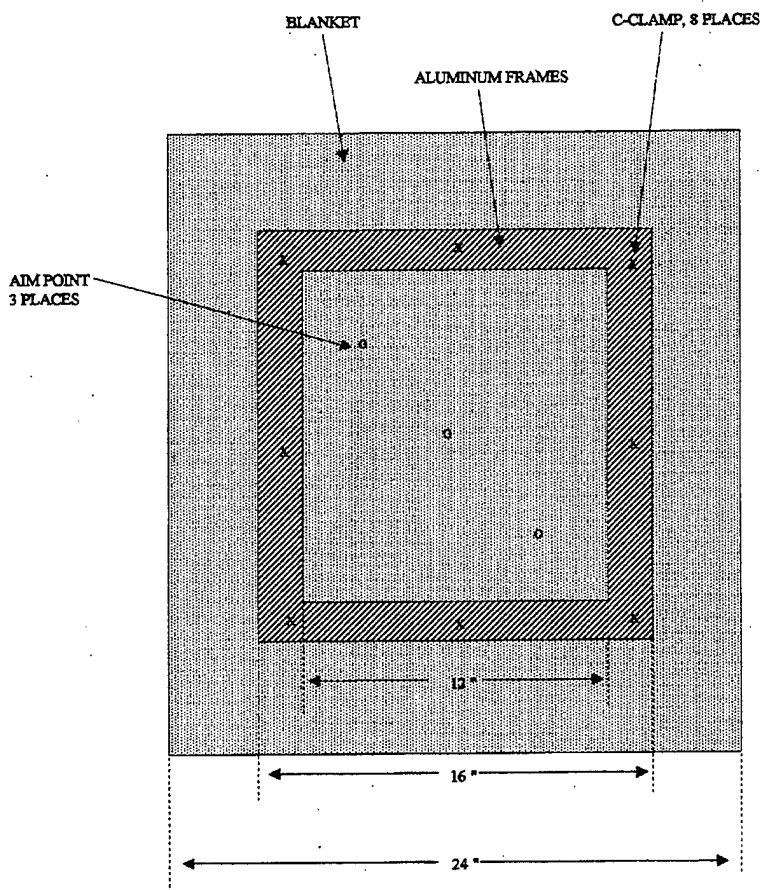

Figure 4. Blanket Clamp.

2.4 Test Layout. A schematic of the test arrangement is shown in Figure 5. Each velocity screen consisted of a grid of fine wires that shorted out and produced an electrical signal when contacted by the fragment. The velocity of the fragment was calculated using the distance between screens and the time between signals. The blanket clamp arrangement was attached to a fixed support using large C-clamps. A 0.020-in-thick 2024-T3 Al plate was placed several inches behind the blanket; this was done to record any fragments that penetrated the blanket and were energetic enough to perforate the witness plate. A 30-in-long container filled with rags was placed just behind the witness plate in order to recover any penetrating fragments. A cardboard box with an aperture was placed in front of the blanket sample to catch the fragment in those tests when it failed to penetrate the blanket. About midway in the test series, we added a yaw card to our test setup in order to check the orientation of the fragment just before it struck the blanket. The yaw card was made using a 0.5-in-thick low-density foam rubber taped to the front surface of a 0.125-in-thick piece of corrugated cardboard; the foam density was 1 lb/ft³.

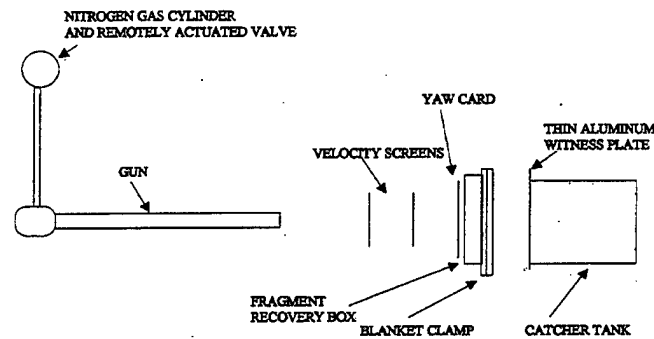

Figure 5. Test Layout.

3. Blanket Samples

We obtained our blanket samples from Thomas Mulkern, Polymer Research Branch, Weapons and Materials Research Directorate (WMRD). All the targets used for ballistic testing were fabricated of DuPont Kevlar 29 fibers. There were two types, which are designated as ARL (U.S. Army Research Laboratory) and FFF (Federal-Fabrics Fibers). The ARL panels were purchased from a weaver, and the fabric is designated as 3,000-denier 17 × 17 plain weave, with an areal weight of 13.6 oz/yd². The FFF materials (ends) were first run through a bath of organic

binder and vermiculite; after drying, the ends were woven into a fabric for ballistic and flame testing. The fibers were 1,500 denier, and the weave was not as tight as that of the ARL fabric, so the areal weight with the vermiculite coating is approximately 4 oz/yd². The following definitions may be helpful:

end = fiber bundle,

denier = weight in grams of a 9,000-m-long end, and

17 × 17 = ends/inch × ends/inch.

We tested two different thicknesses of FFF blankets and three different thicknesses of ARL blankets. Table 1 lists the samples that were tested. The Sample ID column describes the type of sample, number of layers it contains, and a sequential number to identify the sample. Thus, FFF 20-2 is a Federal-Fabrics Fibers sample having 20 layers and it is identified as no. 2 in the 20-layer series.

Table 1. Ballistic Blanket Samples

Sample ID	Weight (lb)	Area (ft ²)	Areal Density (lb/ft ²)
FFF 10-1	1.10	4.00	0.28
FFF 20-1	2.20	4.00	0.55
FFF 20-2	2.30	4.00	0.58
ARL 4-1	1.60	4.34	0.37
ARL 4-2	1.60	4.34	0.37
ARL 4-3	1.60	4.34	0.37
ARL 8-1	3.30	4.34	0.76
ARL 8-2	3.20	4.34	0.74
ARL 8-3	3.30	4.34	0.76
ARL 13-1	5.80	4.34	1.34
ARL 13-2	5.40	4.34	1.24
ARL 13-3	5.30	4.34	1.22

4. Test Results

Thirty fragment impact tests were conducted using the fragment and blanket materials previously described. In seven tests, the blanket sample was backed by a 3/4-in-thick pinewood panel to simulate an actual situation in a munitions stack where a blanket would be in contact with a wooden ammunition crate. In two tests, the flat nose of the steel projectile was machined to make a more pointed configuration to see the effect of concentrating the initial impact force over a smaller area of the blanket. The nose was tapered from a 1/8-in-diameter flat section to the fragment diameter of 0.669 in; the included angle was 60°. We were able to get three impacts on each blanket sample. The first impact was at the center, the second was 4 in from the center toward one corner, and the third was 4 in from the center toward the opposite corner. All the test results are given in Table 2, where P is the total penetration and B is the blanket bulge from its initial position. The blanket bulged in all tests, except those seven tests where a wood backup was used.

Figure 6 is a plot of the recovery depth in packed rags vs. the areal density of the blankets for the ARL and FFF blanket samples. The standard fragment was used for these tests, and the blankets did not have a wood backing. The numbers near each symbol are the fragment velocities. It can be seen that the ARL 4-layer blanket prevented penetration in 4 out of 6 tests, the ARL 8-layer blanket prevented penetration in 6 out of 6 tests, and the ARL 13-layer blanket prevented penetration in 3 out of 3 tests. The FFF 10-layer blanket was penetrated in 3 out of 3 tests, and the FFF 20-layer blanket was penetrated in 3 out of 3 tests. Figure 7 is a plot of areal density of the blankets vs. the number of layers penetrated by the fragment. The penetration of all the ARL blankets ranged from 0 to 5 layers. All layers of the FFF blankets were penetrated.

5. Discussion

When a ballistic blanket is impacted by a fragment, the impact energy is dissipated by the blanket sliding from its clamped position, stretching and tearing. Our data indicate that, for a

Table 2. Test Results

Blanket Type	Fragment Velocity (ft/s)	Impact Location	Result
FFF 10-1	417 (est.)	Center	P = 10 layers + 0.020 in of Al + 8 in of packed rags. B = 2.5 in.
FFF 10-1	452	Corner	P = 10 layers + 0.020 in of Al + 4 in of packed rags. B = 5 in. Fragment was badly tilted.
FFF 10-1	398	Corner	P = 10 layers + 0.020 in of Al + 8 in of packed rags. B = 2 in.
FFF 20-1	466	Center	P = 20 layers + 0.020 in Al + 10 in of packed rags. B = 4 in.
FFF 20-1	408	Corner	P = 20 layers + 0.020 in of Al + 8 in of packed rags. B = 2 in.
FFF 20-1	410 (est.)	Corner	P = 20 layers + 0.020 in of Al + 8 in of packed rags. B = 1.5 in.
FFF 20-2 + wood	423 (est.)	Center	P = 20 layers + 0.75 in of wood + 0.020 in of Al + 8 in of packed rags. B = 0.
ARL 4-1	408	Center	P = 0 layers. B = 5.7 in.
ARL 4-1	413	Corner	P = 2 layers. B = 5 in.
ARL 4-1	455	Corner	P = 4 layers + 0.020 in of Al + 6 in of packed rags. B = 3.5 in.
ARL 4-2	436 (est.)	Center	P = 1 layer. B = 5.7 in.
ARL 4-2	423	Corner	P = 1 layer. B = 5 in.
ARL 4-2	447	Corner	P = 4 layers + 0.020 in of Al + 8.5 in of packed rags. B = 3 in.
ARL 4-3 + wood	423	Corner	P = 4 layers + 0.75 wood + 0.20 in of Al + 9.5 in of packed rags. B = 0.
ARL 8-1	447	Center	P = 0. B = 3.6 in.
ARL 8-1	442	Corner	P = 4 layers. B = 3 in.
ARL 8-1	455	Corner	P = 4 layers. B = 4 in.

Table 2. Test Results (continued)

Blanket Type	Fragment Velocity (ft/s)	Impact Location	Result
ARL 8-2	463	Center	P = 5 layers. B = 4.25 in.
ARL 8-2	449 (est.)	Corner	P = 1 layer. B = 3.75 in.
ARL 8-2	437	Corner	P = 2 layers. B = 4.25 in.
ARL 8-3 + wood	422	Center	P = 4 layers. The 8th layer had an indentation mark of the projectile face. A section of the wood broke away, and there were slight indentations in the Al witness plate caused by the wood spall.
ARL 8-3 + wood	407	Corner	P = 3 layers. The 8th layer had an indentation mark of the projectile face. A piece of the wood broke away and caused spall similar to the preceding test.
ARL 8-3 + wood	418	Corner	P = 3 layers. Results were similar to the two preceding tests.
ARL 13-1	407	Center	P = 1 layer. B = 5.5 in.
ARL 13-1	447	Corner	P = 1 layer. B = 4.6 in.
ARL 13-1	307	Corner	P = 1 layer. B = 4 in.
ARL 13-2	423 (est.) Conical Nose Shape	Center	P = 13 layers + 0.020 in of Al. B = 3.4 in.
ARL 13-3	423 (est.) Conical Nose Shape	Center	P = 13 layers. The projectile ruptured the 13th layer but did not go through the blanket. For this test, the blanket was not clamped as tightly as on all the preceding tests. B = 4.8 in.

similar areal density the ARL 3,000-denier fiber, tight weave appears to be more effective than the FFF 1,500-denier fiber, loose weave. This can be seen in Figure 6 by comparing the results for FFF 20-1 with ARL 4-1 and ARL 4-2. The lower density ARL blanket prevented penetration in 4 out of 6 tests, whereas the higher density FFF material allowed penetration in 3 out of 3 tests. We also did some tests where a wood panel was clamped behind the blanket in order to

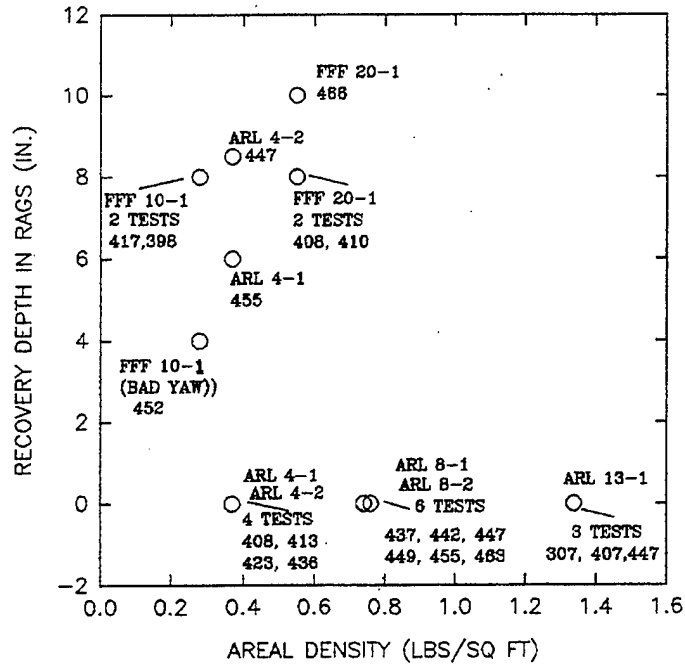

Figure 6. Fragment Recovery Depth in Packed Rags vs. Areal Density of Blanket.

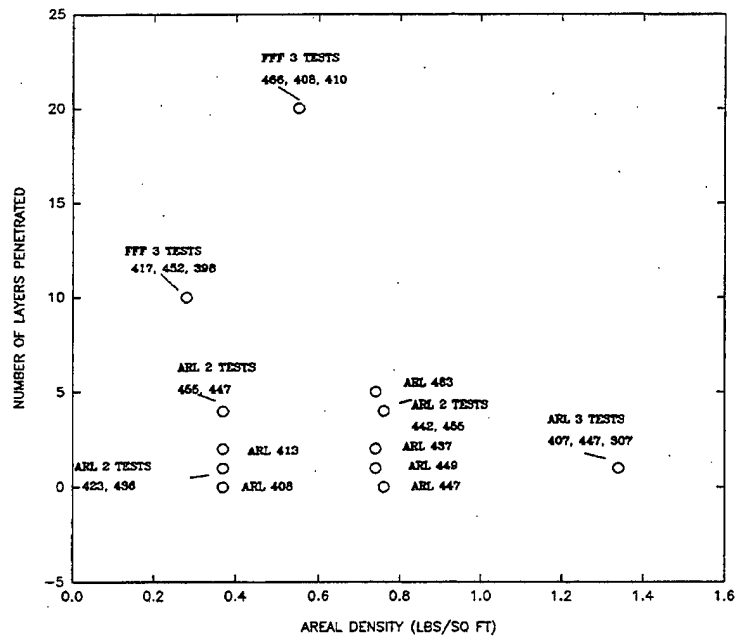

Figure 7. Number of Layers Penetrated by the Fragment vs. Areal Density of Blanket.

simulate the situation where a blanket was covering a wooden ammunition crate. Normally, an impacted blanket will absorb energy by stretching. If it is prevented from stretching, the impact energy should become more localized around the point of impact and cause more layers to be penetrated. Our results indicate that this may be the trend, but the spread in our data could be obscuring this effect. Figure 8 compares the number of layers penetrated for blankets with and without wood backing. The numbers next to the symbols indicate how many tests gave the same penetration.

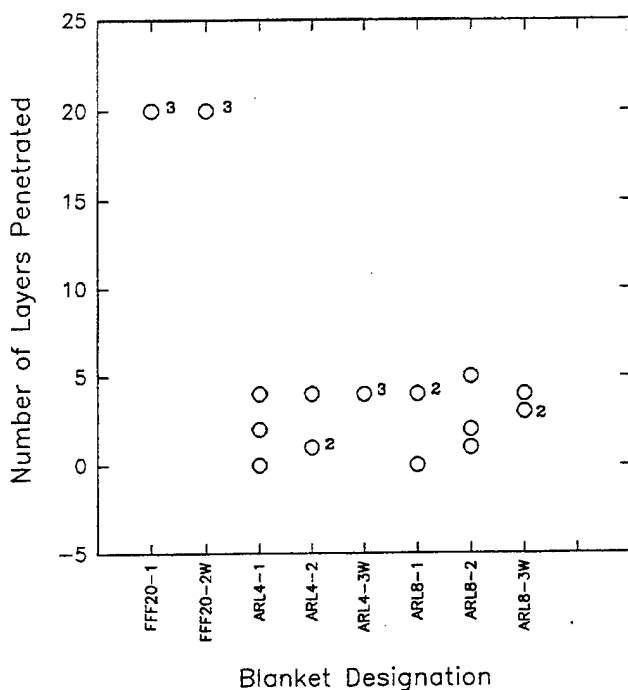

Figure 8. A Comparison of Fragment Penetration Into Blankets With and Without a Wood Back Panel.

Another concentrator of impact energy could be the shape and orientation of the impacting fragment; a long narrow fragment of a given mass, impacting head on, would be expected to penetrate more layers. To demonstrate this, we used the conical nose fragment described previously and impacted a 13-layer ARL blanket. The results can be seen in Table 2 by comparing ARL 13-1 with ARL 13-2 and ARL 13-3. The standard fragment penetrated 1 layer, whereas the conical nose fragment penetrated 13 layers. For the final test, we clamped the

blanket less tightly to see if allowing the blanket to slide a greater distance (bigger bulge) would have an effect on fragment penetration. This test, ARL 13-3, gave a bigger bulge, and the penetration was slightly less than that of the preceding test. However, given the spread in our experimental data, this result was inconclusive.

The variation in the number of layers penetrated for approximately the same fragment velocity may be due to a yawed fragment impacting the blanket; a small amount of yaw could concentrate stress when the edge of the flat-faced fragment strikes the blanket. Our yaw cards did not indicate any large amount of yaw, but we could not get an exact measurement because the base plug and sleeve travelling with the fragment also perforate the yaw card. If yaw is a problem, it is suggested that future tests use a hemispherical nose-shaped fragment or a smooth-barrel full-bore gun to obtain more reproducible data. Instead of clamping the blanket sample, it could be held in place by weights that simulate the mass of a full-size blanket. Also, the residual velocity of the fragment after it penetrated the blanket would probably be a better measure of blanket effectiveness than the recovered depth in packed rags. Since these tests were done using a fragment that impacted the nose first with no rotation or yaw, an unlikely scenario, we believe that the penetration results give a conservative estimate for a 300-g fragment.

6. Conclusions

- (1) For approximately the same areal density, the ARL 3,000-denier tight-weave blanket is more effective for stopping fragments than the FFF 1,500-denier loose-weave material.
- (2) The ARL 8-layer blanket, having an areal density of 0.76 lb/ft^2 , was not penetrated by the standard fragment used in these tests (a flat-faced cylindrical steel fragment with a 0.66-lb weight, 6.7-in length, and 0.67-in diameter). The fragment impacted head on, and its velocity was 450 ft/s.
- (3) When the standard fragment was modified by changing the flat face to a truncated conical nose shape, the fragment penetrated an ARL 13-layer blanket (areal density 1.24 lb/ft^2) in one test and just failed to penetrate in a second test. The shape of the fragment and its orientation at impact have a big effect on blanket penetration.

- (4) The addition of a wood panel behind the blanket gave mixed results. We were not able to determine if the wood backing affected penetration.
- (5) The effect of clamp tightness on penetration could not be determined since there was insufficient data.

<u>NO. OF COPIES</u>	<u>ORGANIZATION</u>
2	DEFENSE TECHNICAL INFORMATION CENTER DTIC DDA 8725 JOHN J KINGMAN RD STE 0944 FT BELVOIR VA 22060-6218
1	HQDA DAMO FDQ D SCHMIDT 400 ARMY PENTAGON WASHINGTON DC 20310-0460
1	OSD OUSD(A&T)/ODDDR&E(R) R J TREW THE PENTAGON WASHINGTON DC 20301-7100
1	DPTY CG FOR RDE HQ US ARMY MATERIEL CMD AMCRD MG CALDWELL 5001 EISENHOWER AVE ALEXANDRIA VA 22333-0001
1	INST FOR ADVNCD TCHNLGY THE UNIV OF TEXAS AT AUSTIN PO BOX 202797 AUSTIN TX 78720-2797
1	DARPA B KASPAR 3701 N FAIRFAX DR ARLINGTON VA 22203-1714
1	NAVAL SURFACE WARFARE CTR CODE B07 J PENNELLA 17320 DAHLGREN RD BLDG 1470 RM 1101 DAHLGREN VA 22448-5100
1	US MILITARY ACADEMY MATH SCI CTR OF EXCELLENCE DEPT OF MATHEMATICAL SCI MAJ M D PHILLIPS THAYER HALL WEST POINT NY 10996-1786

<u>NO. OF COPIES</u>	<u>ORGANIZATION</u>
1	DIRECTOR US ARMY RESEARCH LAB AMSRL DD J J ROCCHIO 2800 POWDER MILL RD ADELPHI MD 20783-1145
1	DIRECTOR US ARMY RESEARCH LAB AMSRL CS AS (RECORDS MGMT) 2800 POWDER MILL RD ADELPHI MD 20783-1145
3	DIRECTOR US ARMY RESEARCH LAB AMSRL CI LL 2800 POWDER MILL RD ADELPHI MD 20783-1145
	<u>ABERDEEN PROVING GROUND</u>
4	DIR USARL AMSRL CI LP (305)

<u>NO. OF</u> <u>COPIES</u>	<u>ORGANIZATION</u>
1	DIRECTOR DEFENSE RSCH AND ENGNRNG DD TWP WASHINGTON DC 20301
1	COMMANDER FIELD COMMAND DSWA FCTTS E MARTINEZ KIRTLAND AFB NM 87115
1	DIRECTOR ADV RSCH PROJECTS AGENCY TECH LIB 3701 N FAIRFAX DR ARLINGTON VA 22203-1714
1	COMMANDER USA ARDEC AMSTA FSM W BARBER BLDG 94 PICATINNY ARSENAL NJ 07806-5000
1	COMMANDER USA ENGINEER DIVISION HNDED FD PO BOX 1500 HUNTSVILLE AL 35807
1	COMMANDER USA CORPS OF ENGRS FT WORTH DSTRCT CESWF PM J PO BOX 17300 FT WORTH TX 76102-0300
1	COMMANDER USA RSCH OFFICE SLCRO D PO BOX 12211 RESEARCH TRIANGLE PARK NC 27709-2211
1	COMMANDER DAVID TAYLOR RSCH CTR TECH INFO CTR CODE 522 BETHESDA MD 20084-5000

<u>NO. OF</u> <u>COPIES</u>	<u>ORGANIZATION</u>
1	OFFICER IN CHARGE CIVIL ENGNRNG LAB NAVAL CONST BATTALION CTR TECH LIB CODE L31 PORT HUENEME CA 93041
1	COMMANDER NAVAL WEAPONS CTR TECH LIB CODE 533 CHINA LAKE CA 93555-6001
1	COMMANDER NSWC DAHLGREN DIVISION LIB CODE E23 DAHLGREN VA 22448-5000
1	COMMANDER NAVAL RSCH LAB TECH LIB CODE 2027 WASHINGTON DC 20375
1	COMMANDER NAVAL WEAPONS EVAL FAC DOCUMENT CONTROL KIRTLAND AFB NM 87117
2	AIR FORCE ARMAMENT LAB AFATL DOIL AFATL DLYV EGLIN AFB FL 32542-5000
1	DIRECTOR LAWRENENC LIVERMORE NATL LAB TECH INFO DEPT L 3 PO BOX 808 LIVERMORE CA 94550
1	NAIC DXLA TECH LIB 4180 WATSON WAY WRIGHT PATTERSON AFB OH 45433-5648
1	KAMAN SCIENCES CORPORATION LIBRARY PO BOX 7463 COLORADO SPRINGS CO 80933-7463

<u>NO. OF COPIES</u>	<u>ORGANIZATION</u>	<u>NO. OF COPIES</u>	<u>ORGANIZATION</u>
1	DIRECTOR SANDIA NATL LAB DOC CONTROL 3141 PO BOX 5800 ALBUQUERQUE NM 87185-5800	3	SOUTHWEST RSCH INSTITUTE C ANDERSON S MULLIN A B WENZEL PO DRAWER 28255 SAN ANTONIO TX 78228-0255
2	LOS ALAMOS NATL LAB RPT COLCTN CIC 14 MS P364 CID 14 MS P364 PO BOX 1663 LOS ALAMOS NM 87545	1	UNIVERSITY OF TEXAS ARL ELCTROMAG GROUP A TUCKER CAMPUS MAIL CODE F0250 AUSTIN TX 78712
1	REPORT COLLECTION AGENCY RSCH LAB MS P362 PO BOX 7113 LOS ALAMOS NM 87544-7113	1	UNIV OF MARYLAND R DICK RM 2168 ENGRG CLASSROOM BLDG COLLEGE PARK MD 20742-5121
1	DIRECTOR SANDIA NATL LAB LIVERMORE LAB DOC CONTROL FOR THE LIB PO BOX 969 LIVERMORE CA 94550	1	US NAVAL ACADEMY TECH LIB 572 HOLLOWAY RD ANNAPOLIS MD 21402-5002
1	DIRECTOR NASA LANGLEY RSCH CTR TECH LIB HAMPTON VA 23665	1	OLIN ORDNANCE RECH LIB J KIBIGER PRODUCT MATERIAL CONTROL 10101 9TH ST N ST PETERSBURG FL 33716
1	SUNBURST RECOVERY INC C YOUNG PO BOX 2129 STEAMBOAT SPRINGS CO 80477	1	COMMANDER INDIAN HEAD DIV NSWC CODE 950T M SWISDAK 101 STRAUSS AVE INDIAN HEAD MD 20640-5035
2	SRI INTERNATIONAL J GRAN B HOLMES 333 RAVEWOOD AVE MENLO PARK CA 94025	1	COMMANDING OFFICER NFESC J TANCRETO ESC62 1100 23RD AVE BLDG 1100 PORT HUENEME CA 93043-4370
2	DENVER RSCH INSTITUTE J WISOTSKI TECH LIB PO BOX 10758 DENVER CO 80210	1	CHAIRMAN DOD EXPOSIVES SAFETY BOARD J WARD HOFFMAN BLDG 1 ROOM 856C 2461 EISENHOWER AVE ALEXANDRIA VA 22331-0600

<u>NO. OF COPIES</u>	<u>ORGANIZATION</u>
1	DEFENSE AMMOLOG ACTIVITY AMSTA AR AL D SCARBOROUGH PICATINNY ARSENAL NJ 07806-5000
1	US ARMY SOLDIER SYSTEMS CMD SSCNS WSO D LEMOINE KANSAS ST NATICK MA 01760-5018
5	USAE WATERWAYS EXP STN CEWES SD R P KINNEBREW B CARNES CEWES TL TECH LIB CEWES SD K DAVIS CEWES SS J WEATHERSBY 3909 HALLS FERRY RD VICKSBURG MS 39180-6199
1	DIR SNL ES HERTEL JR MS 0819 PO BOX 5800 ALBUQUERQUE NM 87185-0307
1	KERLEY PUB SUC G I KERLEY PO BOX 13835 ALBUQUERQUE NM 87192-3835

<u>NO. OF COPIES</u>	<u>ORGANIZATION</u>
	<u>ABERDEEN PROVING GROUND</u>
1	COMMANDER US ARMY TECOM AMSTE TE F L TELETSKI
1	COMMANDER USATC STEC LI
29	DIR USARL AMSRL WM MA W CHIN T MULKERN C PERGANTIS AMSRL WM PB B GUIDOS H EDGE P PLOSTINS P WEINACHT AMSRL WM T A M DIETRICH AMSRL WM TB V BOYLE P BAKER T DORSEY R FREY W HILLSTROM W LAWRENCE R LOTTERO (5CPS) E MCDUGAL J STARKENBERG J WATSON AMSRL WM TC K KIMSEY D SCHEFFLER S SCHRAML AMSRL WM TD P KINGMAN M RAFTENBERG S SCHOENFELD P SIMMERS

REPORT DOCUMENTATION PAGE

Form Approved
OMB No. 0704-0188

Public reporting burden for this collection of information is estimated to average 1 hour per response, including the time for reviewing instructions, searching existing data sources, gathering and maintaining the data needed, and completing and reviewing the collection of information. Send comments regarding this burden estimate or any other aspect of this collection of information, including suggestions for reducing this burden, to Washington Headquarters Services, Directorate for Information Operations and Reports, 1215 Jefferson Davis Highway, Suite 1204, Arlington, VA 22202-4302, and to the Office of Management and Budget, Paperwork Reduction Project(0704-0188), Washington, DC 20503.

1. AGENCY USE ONLY (Leave blank)		2. REPORT DATE November 1999	3. REPORT TYPE AND DATES COVERED Final, Jul 98 - Sep 98	
4. TITLE AND SUBTITLE Munitions Survivability Technology: A Comparison of the Effectiveness of Two Different Blanket Designs for Protecting Against an Indirect Fragment Threat			5. FUNDING NUMBERS JONO 8825F3	
6. AUTHOR(S) Vincent M. Boyle, Alfred L. Bines, and William B. Sutherland				
7. PERFORMING ORGANIZATION NAME(S) AND ADDRESS(ES) U.S. Army Research Laboratory ATTN: AMSRL-WM-TB Aberdeen Proving Ground, MD 21005-5066			8. PERFORMING ORGANIZATION REPORT NUMBER ARL-TR-2122	
9. SPONSORING/MONITORING AGENCY NAMES(S) AND ADDRESS(ES) U.S. Army Defense Ammunition Logistics (Ammolog) Activity			10. SPONSORING/MONITORING AGENCY REPORT NUMBER	
11. SUPPLEMENTARY NOTES				
12a. DISTRIBUTION/AVAILABILITY STATEMENT Approved for public release; distribution is unlimited.			12b. DISTRIBUTION CODE	
13. ABSTRACT (Maximum 200 words) This report describes the results of tests comparing the ballistic effectiveness of two types of Kevlar blanket when impacted by a steel fragment weighing 0.66 lb and having a velocity of 450 ft/s. This fragment, a right circular cylinder, was used to simulate the weight and velocity of a fragment that could be generated when a stack of barricaded M107 munitions detonates and throws fragments upward; when the fragment returns to the ground, the terminal velocity for this weight and shape was calculated to be 450 ft/s. Adjacent barricaded stacks of munitions could be impacted (indirect fragment impact) and react explosively, especially if the fragment is hot. However, if a ballistic blanket covered the ammunition stack, the fragment could be prevented from reaching the munitions. The tests reported here were done using room-temperature fragments. A small gas gun was designed and built to launch the fragments to the required velocity; all fragments impacted the blanket head on. Test results indicate that, for the same areal density, a 3,000-denier tight-weave blanket is more effective for stopping fragments than a 1500-denier loose-weave material. Also, an eight-layer, 3,000-denier blanket having an areal density of 0.76 lb/ft ² prevented fragment penetration.				
14. SUBJECT TERMS munitions survivability, blanket designs, ballistic blankets, fragment penetration			15. NUMBER OF PAGES 24	
			16. PRICE CODE	
17. SECURITY CLASSIFICATION OF REPORT UNCLASSIFIED	18. SECURITY CLASSIFICATION OF THIS PAGE UNCLASSIFIED	19. SECURITY CLASSIFICATION OF ABSTRACT UNCLASSIFIED	20. LIMITATION OF ABSTRACT UL	

INTENTIONALLY LEFT BLANK.

USER EVALUATION SHEET/CHANGE OF ADDRESS

This Laboratory undertakes a continuing effort to improve the quality of the reports it publishes. Your comments/answers to the items/questions below will aid us in our efforts.

1. ARL Report Number/Author ARL-TR-2122 (Boyle) Date of Report November 1999

2. Date Report Received _____

3. Does this report satisfy a need? (Comment on purpose, related project, or other area of interest for which the report will be used.) _____

4. Specifically, how is the report being used? (Information source, design data, procedure, source of ideas, etc.) _____

5. Has the information in this report led to any quantitative savings as far as man-hours or dollars saved, operating costs avoided, or efficiencies achieved, etc? If so, please elaborate. _____

6. General Comments. What do you think should be changed to improve future reports? (Indicate changes to organization, technical content, format, etc.) _____

CURRENT
ADDRESS

Organization

Name

E-mail Name

Street or P.O. Box No.

City, State, Zip Code

7. If indicating a Change of Address or Address Correction, please provide the Current or Correct address above and the Old or Incorrect address below.

OLD
ADDRESS

Organization

Name

Street or P.O. Box No.

City, State, Zip Code

(Remove this sheet, fold as indicated, tape closed, and mail.)
(DO NOT STAPLE)