

EFFECT OF WALL ROTATION ON THE PERFORMANCE OF A HIGH-SPEED COMPRESSOR
CASCADE WITH TIP CLEARANCE

Doukelis A., Mathioudakis K. and Papailiou K.
Lab. of Thermal Turbomachines
National Technical University of Athens, Greece

ABSTRACT

In the present work, the influence of the magnitude of the relative wall speed on the performance of an annular compressor cascade with tip clearance, is examined. Five-hole probe measurements, conducted at the inlet and outlet of the cascade, are used to derive blade performance characteristics, in the form of loss and turning distributions. Characteristics are presented in the form of circumferentially mass averaged profiles, while distributions on the exit plane provide information useful to interpret the performance of the blading. Four different rotational speeds of the hub have been examined, giving the possibility to observe the dependence of performance characteristics on hub rotational speed. Increasing the rotational speed is found to improve the performance of the cascade by decreasing losses in the clearance region, while it affects the flow in the entire passage.

NOMENCLATURE

C_x : Blade axial chord
M: Mach Number
 M_u : Hub peripheral Mach number
 p_t : total pressure
 p_s : static pressure
 Q_{in} : dynamic inlet head at midspan $Q_{in}=p_t-p_s$
T.C.: Tip Clearance
V: velocity
 α : yaw angle relative to axial, $\alpha=\tan^{-1}(\bar{V}_u/\bar{V}_x)$
 $\bar{\omega}$: Pressure loss coefficient, $\bar{\omega}=(\bar{p}_{t1}-\bar{p}_{t2})/(\bar{p}_{t1}-\bar{p}_{s1})$,
up- and down-stream quantities at the same radius
 θ : turning angle, $\theta=\alpha_1-\alpha_2$

Subscripts, Superscripts

1: upstream of the cascade
2: Downstream of the cascade
 x, y, r : axial, circumferential, radial component
 $\bar{\quad}$: Circumferentially mass averaged quantity

INTRODUCTION

The investigation of tip clearance effects is a field of study that has received considerable attention from the

early days of turbomachines development, since the presence of a gap produces losses, which may be of significant amount, while it influences the stability limit of compressors. Research efforts are continuing up to our days, since the related phenomena are not yet fully understood.

Several researchers have proposed models for estimating the losses associated to clearance gaps, these models being able to predict flow features with a degree of success that depends on the configurations examined, including the effect of the relative wall speed. In this respect, compressors and turbines need separate treatment. In compressors the effect of viscous flow transport is in sympathy with the leakage due to blade surface pressure difference, whereas in turbines the effect is opposite. Peacock, (1989), has reviewed methods for estimating tip clearance effects on compressor performance, while Schmidt et al., (1987), have examined applicability of existing correlations to data from a low speed rotor. In order to produce a successful model, a good physical knowledge of the phenomena and the parameters affecting them is necessary. That is why detailed investigations of the flow field are needed and many of them have been performed in recent years.

Dean, (1954), studied the flow in a low-speed linear compressor cascade, for different clearance gap heights and relative wall velocities. Measurements of the static pressure distribution at the suction and pressure side of the blade tip manifested an increase of the leakage vortex intensity with increasing relative wall velocity. This finding was attributed to the induced static pressure decrease on the blade suction surface. Gearhart, (1966), studied the effect of wall relative movement on compressor tip clearance flow by using an ideal 2-D blade inside a rectangular duct filled with water, where the relative movement of the wall was modelled with the use of a moving belt. During the measurements the belt velocity was kept constant and the pressure difference variation between the pressure and suction side of the blade tip gave a measure of the relative influence of the two flow structures: the flow due to the

pressure difference and the flow due to the relative movement of the wall. Four different tip configurations were used and, in all the cases examined, the relative movement between the blade tip and the endwall resulted in an increase of the mass flow rate through the clearance gap. The velocity profiles measured at the tip clearance exit revealed the presence of a uniform jet core, with a large velocity gradient close to the moving wall. Graham, (1985), used a water rig with a moving belt to simulate the relative wall motion over a turbine cascade, in order to provide pressure distributions at midspan and near tip for different tip gaps and wall speeds. Morphis and Bindon, (1988), used an annular turbine cascade to examine the effect of relative wall motion on the pressure distribution of the blade tip. Finally, Yaras et al., (1991), used a turbine cascade with a moving belt to examine the flow inside the tip clearance and downstream of the blade row for various wall speed, providing a very detailed description of the relative wall motion effects.

On the other hand, models based on the physics, as it is revealed from detailed experiments have been shown to be quite successful. For example, the work of Nikolos et al., (1993, 1995, 1996), incorporating a theoretical model for the influence of relative wall motion, gave the possibility to predict radial distributions of flow quantities, including losses, with good agreement with data from cascades and several compressor rotors.

Most of the experimental information, on which attempts for modelling tip clearance size effects have been based, comes from investigations in low-speed rigs. The present investigation, which is part of a continuing experimental activity on tip clearance related phenomena, comes to provide, for the first time, data from a high-speed annular cascade with a hub clearance gap and a rotating hub, representative of realistic compressor operating conditions. The current study deals with cascade performance for varying relative wall velocity, using data from measurements at the inlet and outlet of the cascade. Results from previous investigations, which have focused on the effect of clearance gap size and wall rotation on the cascade performance and the investigation of the 3-D flow structure in the cascade for two different gap sizes, have been presented by Doukelis et al., (1998a,b).

ANNULAR CASCADE CONFIGURATION, EXECUTION OF MEASUREMENTS

Facility

The layout of the annular cascade facility, as well as the principles for its design and construction, have been reported in detail by Mathioudakis et al., (1997). An axial compressor, placed downstream of the cascade, induces the flow in the test cascade. The airstream enters the facility via a smoothly contracting bellmouth into a scroll, which delivers the air flow with a swirl into a contracting axisymmetric "bent duct", giving to the annular space with

hub-tip ratio of 0.75. The test section, on which the test cascade is mounted follows, as can be seen in fig. 1. The cascade has 19 straight blades of a chord of 100 mm, an aspect ratio of 0.8, maximum thickness to chord ratio 4.58%, a solidity of 1.065 at midspan and a 4% chord clearance gap size. The geometrical inlet and outlet angles of the blades are 60.1 deg. and 44.6 deg. from the axial direction respectively, whereas the stagger angle of the blades at midspan is 51.4 deg. The hub wall of the annular space can be rotated via a controlled speed electric motor, creating a relative motion between the endwall and the blade tip.

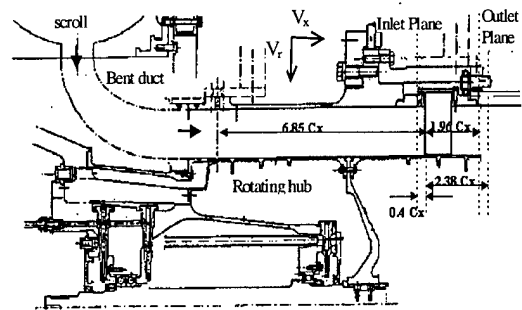

Figure 1: Layout of the test section of the annular cascade facility

Instrumentation and measuring locations

The objective of this work is the study of the effect of the magnitude of variation in the hub wall rotational speed to the performance of an annular compressor cascade. Measurements were conducted for this purpose by a conventional 5-hole probe at the inlet and outlet of the cascade. The maximum local Mach number in the annular space at the cascade inlet was about 0.6, giving a Reynolds number of approximately 1.1×10^6 . Four different hub wall rotational speeds were examined, ranging from hub still to hub rotating at a peripheral Mach number $M_{t0} = 0.504$.

At the cascade inlet (fig. 1), radial traverses were performed at 6 circumferential locations, 0.4 axial chords upstream the leading edge of the blades. The six circumferential locations are fixed with respect to the blades and lie at different blade-to-blade positions. At the cascade outlet (fig. 1), 11 radial traverses were conducted, 1.38 axial chords downstream the trailing edge of the blades. The probe was fixed on the casing, while the cascade was turned at different circumferential positions.

The short-stem 5-hole probe used for the current study has a stem diameter of 3 mm. The 5-hole probe assembly was mounted on a remotely-controlled traversing mechanism. The accuracy in the angular positioning of the cascade is ± 0.1 deg. for a full rotation. The uncertainty of angle measurement for the alignment of the probe carriage,

which is of the order of ± 0.3 deg., yields a systematic error to the measurement of the flow angles of the order of ± 0.3 deg. According to the calibration report of the probe (Schneider and Koschel, 1994) the expected errors of the measured quantities are: ± 0.1 deg. for the yaw and pitch angles, $\pm 0.5\%$ for the total velocity and $\pm 0.6\%$ for the total and static pressure.

CASCADE PERFORMANCE

The influence of the magnitude of the relative wall speed on the performance parameters of the cascade is now presented. First inlet and outlet flow distributions are discussed, followed by distributions of losses and turning.

Inlet and Outlet Conditions

Measurements at the annular cascade inlet and outlet were performed for each rotational speed under study. Figures 2 and 3 show the circumferentially mass averaged profiles at the inlet and outlet of the cascade, for the four cases of hub rotation. The total pressure gradient at the inlet mid-passage, fig 2c, has been produced at the scroll exit as a consequence of the shear layers generated inside the inlet bellmouth and the scroll. Data from different circumferential locations at the exit of the connecting duct indicate the presence of uniform total pressure around the midspan, for locations corresponding to the flow path of the initial length of the scroll spiral centreline. Circumferential locations at further downstream positions, where the scroll cross section has become smaller and flow has travelled a much longer distance, show a non-uniform profile all over the

The gradients of total pressure close to the hub and casing closely resemble customary boundary layers. The inlet boundary layer is thicker in the hub region, covering the lower 25% of the passage, whereas the boundary layer in the outer casing covers the upper 10% of the passage, as shown in fig. 2(c). The influence of hub wall rotation is felt mainly in the lower 15% of the passage, inside the hub boundary layer. The total pressure profile at the inlet and outlet of the cascade is less steep near the wall as the rotational speed is increased, leading to a higher total pressure near the hub because of the increased energy transfer from the moving wall to the fluid.

The yaw angle is also influenced by variation in the relative wall speed. An increase in hub rotational speed entrains the fluid near the wall and changes the flow angle profile, as shown in fig. 2(b). As one would expect, near the wall the angle increases and it would be expected to arrive to a value of 90° on the wall. This behaviour has a significant consequence on the operation of the cascade. While with the hub wall stationary the blade operates at a maximum local incidence of about 5° , as the rotational speed is increased the incidence decreases by as much as 2.5° in the lower 10% of the blade span, for the higher rotational speed. Finally, Mach number is also influenced, showing larger values in the vicinity of the hub wall, as the

relative wall velocity is increased.

The distributions of flow quantities at the upstream location were independent of the size of the clearance gap. Circumferential non-uniformity was found to be very small on a blade passage scale (Mathioudakis et al., 1997).

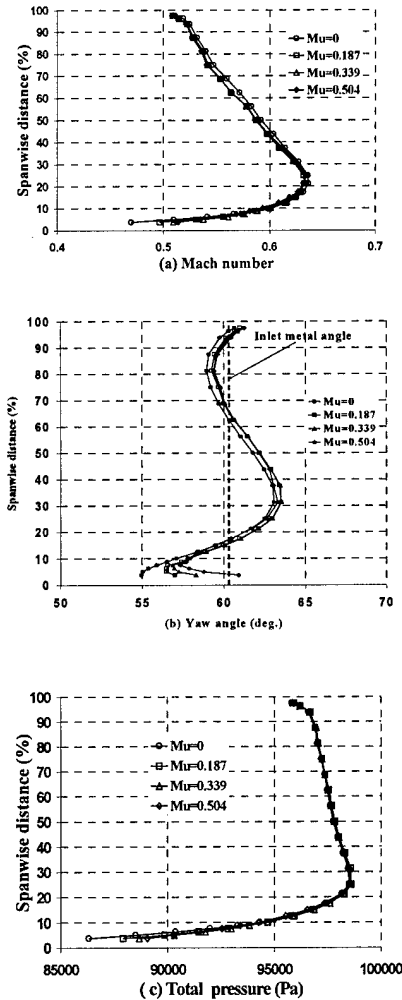

Figure 2: Flowfield properties at the cascade inlet

The following remarks can be made on the cascade outlet flow properties (fig. 3):

- The hub viscous layer is significantly thicker than upstream, extending up to 50% blade span, and is thicker for low wall relative velocities.
- For all the quantities the gradients in the hub region are steeper for lower rotational speeds.
- The changes in the hub viscous layer clearly influence the remaining upper part of the passage. For this part the blockage effect results in higher Mach numbers in low rotational speeds.
- The tip viscous layer does not seem to have been significantly influenced by the development of the hub

layer, in any case.

The distributions of Mach number and yaw angle at the cascade outlet over an area corresponding to one blade passage are shown in figures 4 and 5. The dashed outline represents the passage projection along the trailing edge metal angle of the blades.

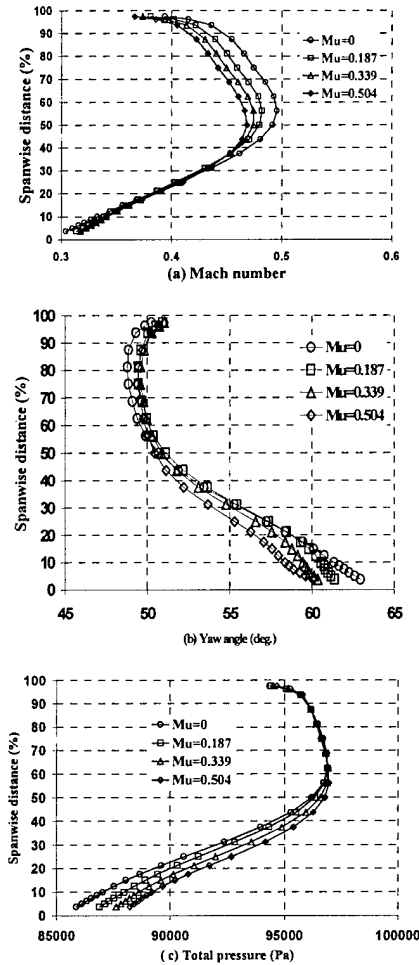

Figure 3: Flowfield properties at the cascade outlet

An area of low Mach numbers covers the region near the hub wall, indicating a thick boundary layer at this location. The radial extent of this area is larger for the stationary hub, and it grows thinner as the hub rotational speed is increased. An area of low values, corresponding apparently to the blade wake extends through the upper part of the passage. The wake still persists at 1.38 axial chords downstream, while it is skewed because of the radial variation of flow angle. Distributions of flow angle, fig. 5, show that there are small circumferential variations, while significant radial variations with higher angle values near the hub are observed for the lower rotational speeds.

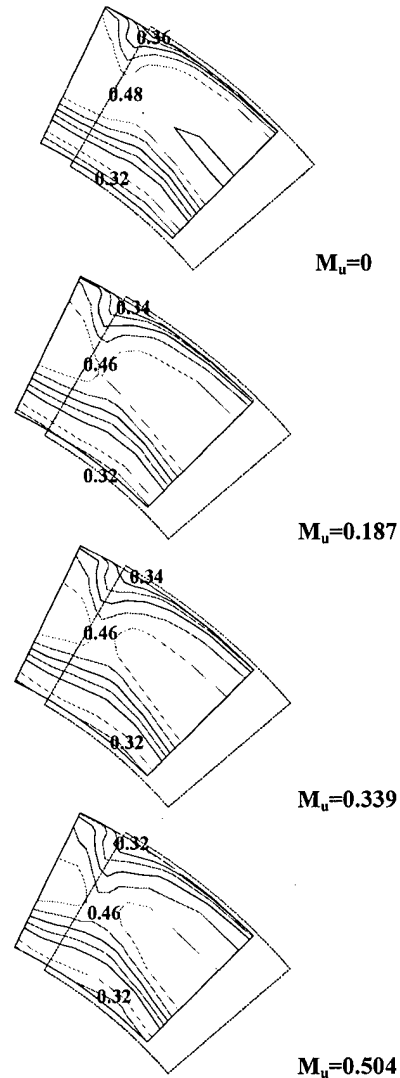
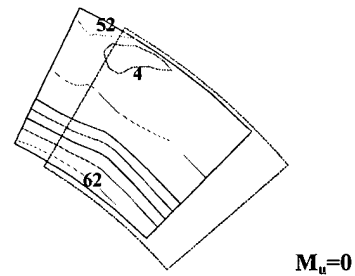

Figure 4: Mach number distributions at the cascade outlet (step=0.02)



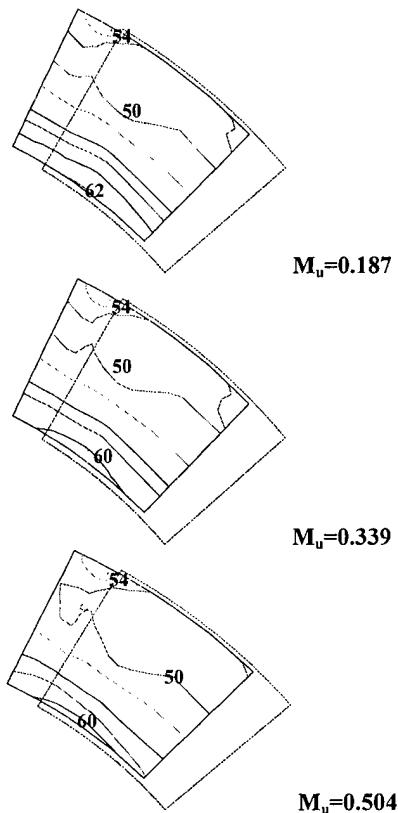

Figure 5: Yaw angle distributions at the cascade outlet (step=2 deg.)

Cascade Performance Parameters

We will now examine the performance of the cascade for different relative hub wall speeds. The cascade performance is examined through the loss coefficient ω and the turning angle θ . These parameters are derived by circumferentially mass averaging the measured distributions of flowfield properties.

Although the use of an alternative pressure loss coefficient, based on the streamlines, would be desirable in view of the three-dimensionality of the flow under study, this would be possible only if detailed enough data for the flow within the passage were available.

Figure 6 shows the pressure loss coefficient for all cases of relative wall speed. The loss distributions indicate a region of high losses in the lower half of the passage, which is the clearance influence region. Lower values, with no significant variation are observed in the upper half, with a local increase near the tip endwall. The magnitude of the losses is significantly larger for lower rotational speeds, a difference that can be attributed to two factors: (a) rotation of the hub wall energises the boundary layer, transferring energy to the flow, with beneficial

effect on both the inlet viscous layer and its subsequent development through the passage, (b) the fact that, in the lower relative wall velocities, the hub section of the blade operates at higher incidence angles, favouring the rapid development of both endwall and blade boundary layers, and resulting in a thicker shear layer at the exit of the cascade. It should be mentioned that the form of the loss coefficient distribution observed here for the clearance region, is the typical one obtained by other experiments as well as theoretical analysis of tip clearance losses (Nikolos et al., 1996).

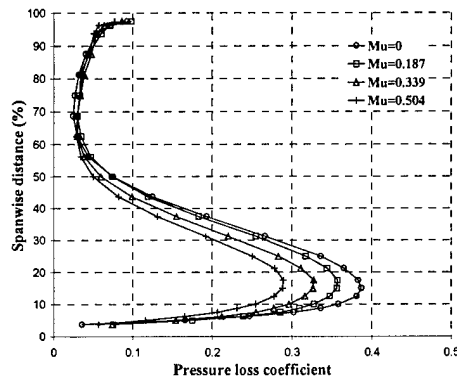

Figure 6: Spanwise distribution of circumferentially mass averaged pressure loss coefficient for varying hub rotational speed

Performance of the cascade in terms of turning angle can be seen in fig.7. It is observed that the turning angle remains approximately constant in the upper half of the passage while it is increased significantly in the lower one, as the hub rotational speed is increased. The lower 10% even exhibits negative turning angles for the lower rotational speeds, indicating significant viscous action in the passage, which must have included some form of 3-D separation.

An additional insight on the features of the flow related to the above observations can be gained from observation of fig. 8, where the distribution of local loss coefficient at the outlet of the cascade, over an area corresponding to one passage is shown. The isocontours

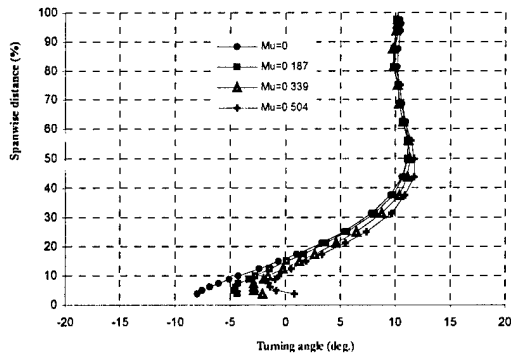

Figure 7: Spanwise distribution of circumferentially mass averaged pressure turning angle for varying hub rotational speed

show islands of high loss, attributed to the presence of a leakage vortex, not mixed-out yet at this axial location. The size of this island, for loss above a certain level, is consistently becoming smaller as the hub rotational speed is increased, being consistent with the observations derived from the mass-averaged distributions.

The variation of the overall pressure loss coefficient of the cascade and the maximum loss coefficient (occurring at about 13% height from the hub) is presented, in fig.9. It is observed that while at small rotational speeds the overall loss does not seem to be influenced by the rotation of the hub, further increase leads to loss overall loss coefficient reduction. The local loss coefficient on the other hand is continuously decreasing with hub speed. This behaviour reflects the change of loss coefficient distribution over the height, shown in figure 6. The reduction of the local values as the speed increases is compensated by a small increase at the upper half of the passage, which does not happen as the speed increases further.

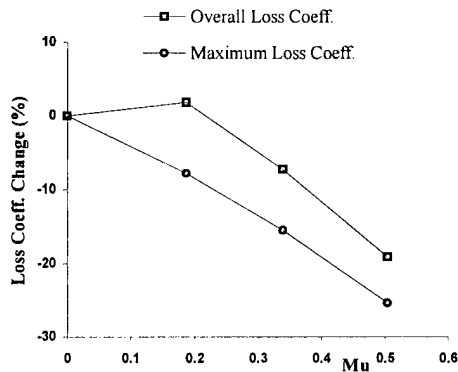

Figure 9: Overall and maximum local total-pressure loss coefficient variation, in function of the hub speed.

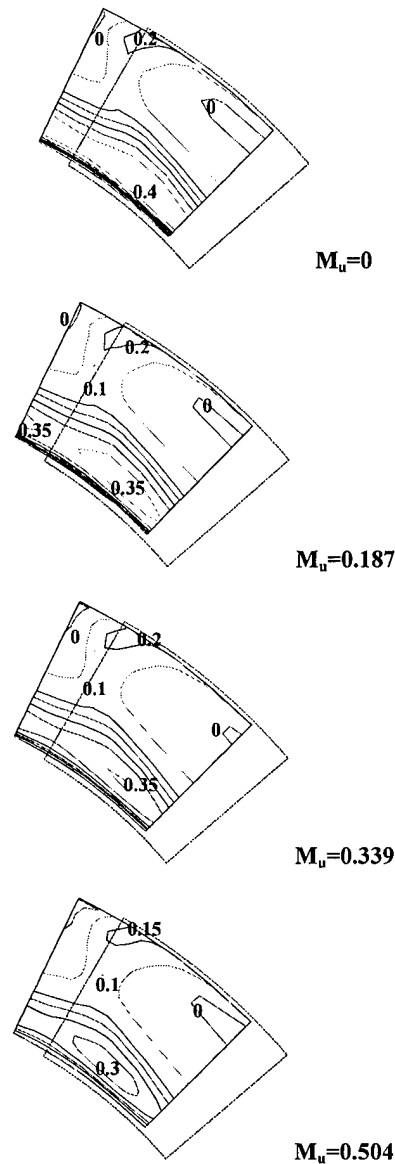

Figure 8: Pressure loss coefficient distributions (step=0.05)

Finally, the variation of turning angle within the wall influence region is presented in figure 10. It is shown that the turning performance is enhanced as the rotational speed increases, and the influence becomes less pronounced as we move further from the wall.

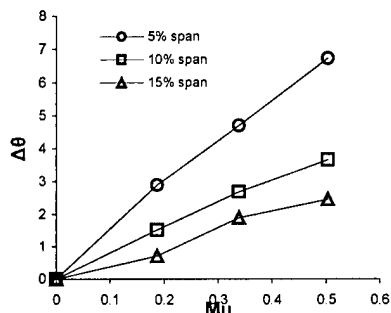

Figure 10: Turning angle variation (difference from value when hub is still), in function of the hub speed, for different spanwise locations.

CONCLUSIONS

In the present work, an experimental investigation of the influence of the magnitude of the relative wall speed on the performance of a high-speed annular compressor cascade with tip clearance has been conducted. Five-hole probe measurements, conducted at the inlet and outlet of the cascade for four different rotational speeds of the hub, have been used to derive blade performance characteristics, in the form of loss and turning distributions. Increasing the hub rotational speed was found to improve the performance of the cascade by decreasing losses in the clearance region and creating a more favourable operating condition than the stationary wall case, while it affects the flow in the entire passage. The favourable operating conditions is attributed to the changes of local incidence as a result of entrainment, and energy transfer from the hub wall to the boundary layer.

REFERENCES

- DEAN R. C., 1954, "The Influence of Tip Clearance on Boundary Layer Flow in a Rectilinear Cascade", Massachusetts Institute of Technology, Gas Turbine Laboratory, Report no. 27-3, December 1954.
- DOUKELIS A., MATHIOUDAKIS K. AND PAPAILIOU K., 1998, "The Effect of Tip Clearance Size and Wall Rotation on the Performance of a High-Speed Annular Compressor Cascade", *ASME paper* 98-GT-38, 1998.
- DOUKELIS A., MATHIOUDAKIS K. AND PAPAILIOU K., 1998, "Investigation of the 3-D Flow Structure in a High-Speed Annular Compressor Cascade for Tip Clearance Effects", *ASME paper* 98-GT-39, 1998.
- GEARHART W. S., 1966, "Tip Clearance Cavitation in Shrouded Underwater Propulsors", *AIAA Journal of Aircraft*, March - April, vol. 3, no. 2, 1966.
- GRAHAM J. A. H., 1985, "Investigation of a Tip Clearance Cascade in a Water Analogy Rig", *ASME paper*

85-IGT-65, 1985.

MATHIOUDAKIS K., PAPAILIOU K., NERIS, BONHOMMET C., ALBRAND G., WENGER U., 1997, "An Annular Cascade Facility for Studying Tip Clearance Effects in High Speed Flows", *XIII ISOABE*, Sept. 8-12, 1997, Chattanooga, Tennessee, USA.

MORPHIS G., BINDON J. P., 1988, "The Effects of Relative Motion, Blade Edge Radius and Gap Size on the Blade Tip Pressure Distribution in an Annular Turbine Cascade With Clearance", *ASME paper* 88-GT-256, 1988.

NIKOLOS J., DOUVIKAS D., PAPAILIOU K., 1993, "A Method for the Calculation of the Tip Clearance Flow Effects in Axial Flow Compressors., Part I: Description of Basic models Part II: Calculation procedure", *ASME papers* 93-GT-150 and 93-GT-151, 1993.

NIKOLOS J., DOUVIKAS D., PAPAILIOU K., 1995, "Theoretical Modelling of Relative Wall Motion Effects in Tip Leakage Flow", *ASME paper* 95-GT-88, 1995.

NIKOLOS J., DOUVIKAS D., PAPAILIOU K., 1996, "Modelling of the Tip Clearance Losses in Axial Flow Machines", *ASME paper* 96-GT-72, 1996.

PEACOCK R.E., 1989, "Turbomachinery Tip Gap Aerodynamics - A Review", *9th ISABE*, 1989, Athens, Greece, 1989.

SCHMIDT M. J. P., AGNEW B. AND ELDER R. L., 1987, "Tip Clearance Flows - Part 1, Experimental Investigation of an Isolated Rotor", *8th ISABE*, Cincinnati, Ohio, USA, pp. 291-297, June 14-19, 1987.

SCHNEIDER A. AND KOSCHEL W., 1994, "Five Hole Pressure Probe 955-01, no. 1, Calibration Report", Institut für Strahlantriebe und Turboarbeitsmaschinen, Rheinisch-Westfälische Technische Hochschule, Aachen, 1994.

YARAS M. I., SJOLANDER S. A., KIND R. J., 1991, Effects of Simulated Rotation on Tip Leakage in a Planar Cascade of Turbine Blades. Part I: Tip Gap Flow, Part II: Downstream Flow Field and Blade Loading", *ASME papers* 91-GT-127 and 91-GT-128, 1991.

ACKNOWLEDGMENTS

The work has been performed within the frame of the contract BRPR-CT97-0610, and the financial assistance of the C.E.U. is gratefully acknowledged.

Back