

USAARL Report No. 2000-10

# Prescribing Bifocal Spectacles for U.S. Army Aviators

by

Corina van de Pol, Stephen E. Morse, Brian Brown, Gordon C. Hendricks,  
Deborah R. Towns, Steven R. Gilreath, Nina S. Jones, and Morris R. Lattimore, Jr.



Aircrew Health and Performance Division

January 2000

Approved for public release, distribution unlimited.

20000223 031

U  
S  
A  
A  
R  
L

U.S. Army  
Aeromedical Research  
Laboratory

## Notice

### Qualified requesters

Qualified requesters may obtain copies from the Defense Technical Information Center (DTIC), Cameron Station, Alexandria, Virginia 22314. Orders will be expedited if placed through the librarian or other person designated to request documents from DTIC.

### Change of address

Organizations receiving reports from the U.S. Army Aeromedical Research Laboratory on automatic mailing lists should confirm correct address when corresponding about laboratory reports.

### Disposition

Destroy this document when it is no longer needed. Do not return it to the originator.

### Disclaimer

The views, opinions, and/or findings contained in this report are those of the author(s) and should not be construed as an official Department of the Army position, policy, or decision, unless so designated by other official documentation. Citation of trade names in this report does not constitute an official Department of the Army endorsement or approval of the use of such commercial items.

### Human use

Human subjects participated in these studies after giving their free and informed voluntary consent. Investigators adhered to AR 70-25 and USAMRMC Reg 70-25 on Use of Volunteers in Research.

<b>REPORT DOCUMENTATION PAGE</b>				Form Approved OMB No. 0704-0188	
1a. REPORT SECURITY CLASSIFICATION Unclassified		1b. RESTRICTIVE MARKINGS			
2a. SECURITY CLASSIFICATION		3. DISTRIBUTION / AVAILABILITY OF REPORT Approved for public release, distribution unlimited			
2b. DECLASSIFICATION / DOWNGRADING					
4. PERFORMING ORGANIZATION REPORT NUMBER(S) USAARL Report No. 2000-10		5. MONITORING ORGANIZATION REPORT NUMBER(S)			
6a. NAME OF PERFORMING ORGANIZATION U.S. Army Aeromedical Research Laboratory		6b. OFFICE SYMBOL (If MCMR-UAD	7a. NAME OF MONITORING ORGANIZATION U.S. Army Medical Research and Materiel Command		
6c. ADDRESS (City, State, and ZIP Code) P.O. Box 620577 Fort Rucker, AL 36362-0577		7b. ADDRESS (City, State, and ZIP Code) 504 Scott Street Fort Detrick, MD 21702-5012			
8a. NAME OF FUNDING / SPONSORING ORGANIZATION		8b. OFFICE SYMBOL (If	9. PROCUREMENT INSTRUMENT IDENTIFICATION NUMBER		
8c. ADDRESS (City, State, and ZIP Code)		10. SOURCE OF FUNDING NUMBERS			
		PROGRAM ELEMENT NO. 0602787A	PROJECT NO. 3M162787A879	TASK NO. X3	WORK UNIT ACCESSION NO.
11. TITLE (Include Security Classification) (U) Prescribing Bifocal Spectacles for U.S. Army Aviators					
12. PERSONAL AUTHOR(S) C. Van de Pol, S. Morse, B. Brown, G. Hendricks, D. Towns, S. Gilreath, N. Jones, M. Lattimore					
13a. TYPE OF REPORT Final		13b. TIME COVERED FROM TO	14. DATE OF REPORT (Year, Month, 2000 January		15. PAGE COUNT 32
16. SUPPLEMENTAL NOTATION					
17. COSATI CODES			18. SUBJECT TERMS (Continue on reverse if necessary and identify by block number) bifocal spectacles, Flight Duty Medical Examination, Snellen, operationally-optimal bifocal		
FIELD	GROUP	SUB-GROUP			
06	04	03			
19. ABSTRACT (Continue on reverse if necessary and identify by block number) This technical report is geared towards clinicians that prescribe bifocal spectacles for Army aviators. The bifocal add required to pass the Flight Duty Medical Examination (FDME) is based on a 14 - inch testing distance and is often too strong for use in the cockpit. Cockpit working distances are generally 18 to 36 inches. This guide provides the clinician with more information about the expected near working distances in specific Army aircraft. A description of each aircraft, a diagram of the cockpit layout, distances to each of the control panels and the Snellen equivalent letter size of instrumentation is detailed. The final part of the paper uses an example to aid in determination of the operationally-optimal bifocal add power and segment height.					
20. DISTRIBUTION / AVAILABILITY OF <input checked="" type="checkbox"/> UNCLASSIFIED/UNLIMITED <input type="checkbox"/> SAME AS RPT. <input type="checkbox"/> DTIC USERS			21. ABSTRACT SECURITY CLASSIFICATION Unclassified		
22a. NAME OF RESPONSIBLE INDIVIDUAL Chief, Science Support Center		22b. TELEPHONE (Include Area (334) 255-6907		22c. OFFICE SYMBOL MCMR-UAX-SS	

DTIC QUALITY INSPECTED 1

## Table of contents

	<u>Page</u>
Introduction .....	1
Background .....	1
Methods.....	2
Results and Discussion.....	3
Add power requirements .....	4
Nearpoint distances in the cockpit .....	4
Nearpoint acuity demand .....	4
Bifocal segment height.....	4
Recommended testing and prescribing procedure .....	5
References .....	6

## Appendices

A. Summary table of the range of instrument distances and letter sizes.....	7
B. Letter type conversion chart .....	9
C. Army aircraft descriptions, instrument panel diagrams and measurements.....	11
AH-1S Cobra.....	12
AH-64A/D Apache.....	14
RAH-66 Comanche .....	16
CH-47D Chinook .....	17
OH-58A/C Kiowa .....	19
OH-58D Kiowa Warrior.....	21

Table of contents (continued)

	<u>Page</u>
TH-67 Creek.....	23
UH-1H Iroquois .....	25
UH-60 Series Blackhawk.....	27
U-21A.....	29
C-12 Huron.....	31

List of figures

The standard seating geometry guide for military aircraft. (Figure from MIL-STD-1333B).....	3
---	---

## Introduction

Clinically determining the operationally-appropriate bifocal spectacle correction for aviators presents a unique problem. Army Regulation (AR) 40-501 stipulates that the near visual acuity test on the Flight Duty Medical Examination (FDME) be conducted at 14 inches. This near test distance does not correspond at all with typical flight instrument viewing distances of 18 to 36 inches. Therefore, if the examining and prescribing clinician is not familiar with aircraft layout and cockpit visual requirements, the near add required for the aviator to pass the flight physical is too strong in power for clear, comfortable instrument visualization. This report was prepared to educate and assist the clinical community in arriving at an operationally-appropriate add for their aviator patients. It includes basic operational information on each aircraft to allow clinicians to become more familiar with the diverse visual requirements encountered by Army aviators.

## Background

The relationship between increasing chronological age and decreasing ability to focus on near objects has been studied extensively over the past hundred years (Donders, 1864; Duane, 1909; Hamasaki, Ong and Marg, 1956). From the ages of 14 to 45, there is a constant decline in accommodative ability which manifests itself in an individual's early 40's as presbyopia, (i.e., the inability to clearly and comfortably meet near visual demands). This can manifest as full time blur at near, inability to maintain clarity at near, delays in achieving near focus within a certain near range, or even transient distance blur after an extended near-point task (Borish, 1970). Presbyopia is progressive, reaching the point of total effective loss of accommodative ability by age 65. The impact of presbyopia in the cockpit is to diminish the ability to read quickly and accurately various instruments and charts. This is attributed to both a decreased near visual acuity, and an increase in focusing time from outside to inside the aircraft, and the reverse. Paradoxically, while the maturing process interferes with in-cockpit visual performance, it happens in the very people with the most experience and background knowledge. Therefore, the prescribing of an operationally-appropriate near correction carries operational importance.

As mentioned earlier, the process of determining the optimum visual correction for the senior aviator is not a simple task. The need for a prescription that provides sharp distance visual acuity in the military aviator is obvious. If distance visual acuity is found to be decreased (i.e., worse than 20/20), spectacles should be ordered and required for the performance of flight duties. On the other hand, the necessity to prescribe correction for near vision is not as clear-cut. The Armed Forces Vision Test Apparatus-Near/Distance (VTA-ND) is set for a 13-inch near testing distance, and the Armed Forces Near Point Card is calibrated for 14 inches. Testing at these distances is helpful in identifying those individuals requiring a spectacle correction for desk work, but these distances do not necessarily correlate with reading flight instruments or performing other cockpit tasks.

The viewing distances for most aircraft instrument panels exceeds nearly twice the normal clinical test distances. Obviously, it is inappropriate to base near vision standards for flying exclusively on the findings of the VTA-ND or, for that matter, on the instrument panel distances alone. Thus, a presbyopic aviator's visual needs may or may not require near vision correction

and must be assessed on an individual basis with reference to the specific aircraft routinely flown by the aviator.

The normal solution to the near vision problems associated with presbyopia is a pair of multifocal (usually bifocal) spectacle lenses. The clinical determination of the proper near lens power is based on what is felt to be an "average" working distance of 40 centimeters (cm) or 16 inches (Morgan, 1970). However, aviators who are typically tested at a near vision distance of 14 inches (35 cm), commonly are prescribed a near bifocal correction based on the 14-inch distance. This excessive near correction can induce an intermediate viewing distance blur at arm's length where many instruments are located. A fundamental problem has been that most eye care practitioners are unfamiliar with and lack the specific technical data to adjust the near power add prescription for each individual aviator in each different aircraft. In order for the eye care practitioner to determine the proper near prescription, he/she must have the data available that specify distances to near targets in different aircraft. Therefore, this publication is devoted to furnishing the practitioner with information that will help him/her provide each presbyopic aviator patient with the optimum spectacle correction.

### Methods

The following U.S. Army aircraft were included in this study:

1. AH-1S Cobra;
2. AH-64A/D Apache;
3. RAH-66 Comanche (LH) developmental;
4. CH-47D Chinook;
5. OH-58A/C Kiowa;
6. OH-58D Kiowa Warrior;
7. TH-67 Creek;
8. UH-1H Iroquois;
9. UH-60A Blackhawk;
10. U-21A Twin engine, fixed wing;
11. C-12 Huron.

To determine the distance to the instrument panels in each aircraft, a reference point representing the average aviator's eye position was needed. The "design eye position" is specified in Military Standard (MIL-STD)-1333B. The Figure is a reproduction of the diagram describing the key reference points for establishment of the design eye position for U.S. Army aircraft. Physical measurements were taken for the distances from the x, y, and z spatial coordinates for the average aviator's eye position to each of the major instrument panels.

To determine the equivalent letter size of the instrument displays, the alphanumeric details on each instrument were measured and compared to the letter sizes of a standard Snellen nearpoint card. The ranges of letter sizes for each instrument panel were recorded.

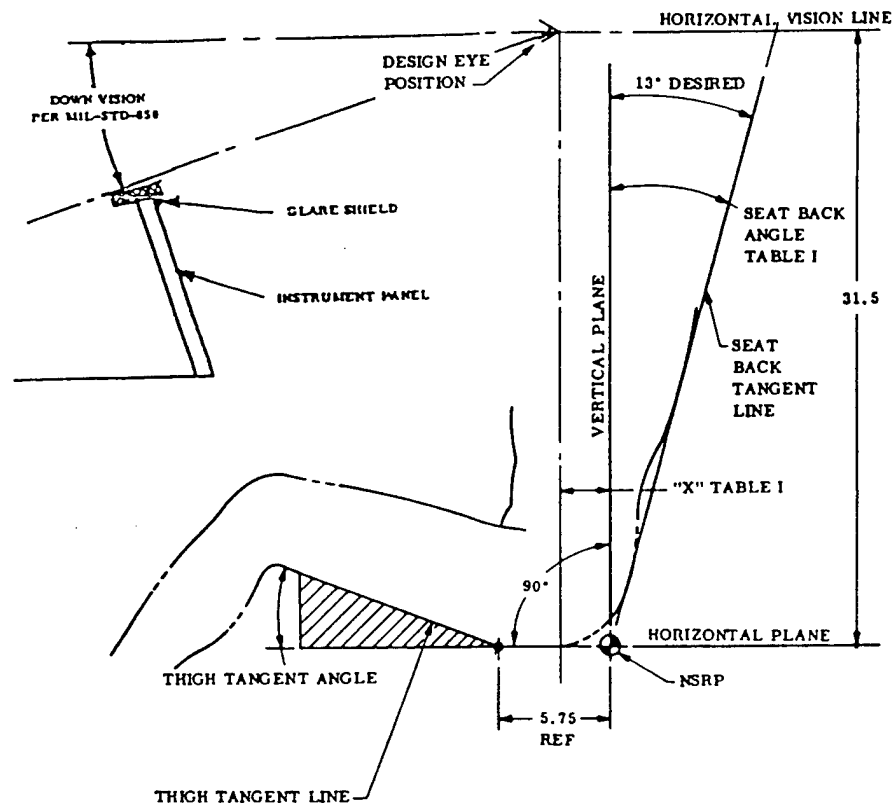

Figure. The standard seating geometry guide for military aircraft. The design eye position is located along the horizontal vision line anterior to the vertical plane defined by the neutral seat reference point (NSRP). For purposes of this study the seatback angle of 13° was used resulting in a 6-inch forward displacement of the design eye position from the vertical plane. (Figure from MIL-STD-1333B)

The angular distance between "eyes straight ahead" and "eyes depressed to the top of the glare shield on the instrument panel" was the measurement used to determine appropriate bifocal segment height.

### Results and Discussion

A consolidated table of the range of instrument distances and letter sizes is provided as an easy reference at Appendix A. A table showing the conversion between Snellen and Jaeger nearpoint letter sizes is given at Appendix B. These tables are intended to provide the clinician with the basic information needed to determine the appropriate bifocal add power for the aviator.

## Add power requirements

### Nearpoint distances in the cockpit

Reading maps and charts is a generic requirement for all aviators. Most aviators use either a kneeboard or hold their charts at a closer distance for viewing. For these tasks, vision needs to be clear between 16 and 18 inches (40 to 45 centimeters). The primary working distance in the cockpit is between 26 and 43 inches (66 to 109 cm). Each aircraft has a different range of working distances requiring consideration of the individual aircraft to determine the optimal add power. More detailed information on each aircraft, to include individual instrument panels and cockpit layout diagrams, is included at Appendix C.

### Nearpoint acuity demand

The greatest visual demand involves reading 20/25 equivalent letter sizes on maps, charts and approach plates at 16-18 inches. The most common letter size for instrument panels is generally a 20/70 equivalent. Again, individual aircraft configurations and displays vary. See Appendices A and C.

## Bifocal segment height

It was determined that the average angular distance between "eyes straight ahead" and "eyes depressed to the top of the glare shield on the instrument panel" was 30 degrees. This corresponds to an average segment position of 7mm below the line of sight when the pilot is in primary gaze. Since the distance optical center of a bifocal lens is generally 2mm above the segment, the effects and solutions for unequal vertical prism should be considered in cases of anisometropia greater than 1 diopter in the vertical meridian. The actual segment height will vary depending on individual spectacle fit and head position (see next section).

While there are at least four important variables that affect bifocal segment height (seat back angle, seat height, horizontal seat position, and pilot height), the eye care practitioner is very familiar with the most important factor: the height of the patient; i.e., tall patients usually require lower bifocal segment heights than short patients. In almost every case, the potential variability in optimum bifocal segment height due to seat back angle, seat height, and horizontal seat position is cancelled by the influence of aviator height. For example, the seat back angle can vary from 10 to 15 degrees, but actually produces no measurable change in the angular distance between "eyes straight ahead" and "eyes depressed to the top of the glare shield on the instrument panel" due to a compensating head tilt that involuntarily accompanies the change in seat back angle. Similarly, the seat height alone did not influence the angular distance, as tall aviators typically adjusted the seat low, and short aviators adjusted the seat high. Horizontal seat position was similarly influenced by aviator height, with tall aviators adjusting the seat backward, and short aviators adjusting the seat forward.

There are exceptions to the typical relationships between pilot height and the other variables. Some aviators prefer to adjust the seat all the way down and all the way back regardless of the height factor - presumably to be better protected by the armor plating during combat operations.

There are other exceptions possible, but the eye care clinician can take these into account by questioning each aviator regarding the typical seat position used during operational flight and adjust the segment height appropriately.

#### Recommended testing and prescribing procedure

Example: 50 year old, UH-60A Blackhawk pilot

1. Determine the distant spectacle prescription.
2. With the distant spectacle correction in place, hold the near Snellen test card or other near card at appropriate instrumentation distances for the aviator's aircraft and determine the optimum near power needed to obtain the proper acuity at key distances.

Example: For the test distances and test letter sizes, turn to page 8, Appendix A, for the UH-60 Blackhawk series aircraft. By holding the Armed Forces near test chart at the midrange of the primary instrument panel (33.5 inches) and directing the patient's attention to the 20/70 line, an over-refraction can be performed to determine the proper add power. The range of clear vision with this bifocal add should then be measured. Adjustments to the add power may be required if the pilot is unable to read over the entire range given in Appendix A. The effect of the add power on the visibility of any instrument cluster can be tested by moving the near test card to different instrument distances, as specified in Appendix C, while the aviator wears the proposed add in a trial frame.

3. Using the add power determined in Step 2, verify that the aviator is able to see the smaller print required for reading maps and charts (20/25 to 20/40) at the closer distance. If the aviator is unable to adequately perform this task a higher add power or trifocals may have to be considered.
4. Using a properly adjusted aviator frame, with plano lenses or the aviators own frame with old prescription, mark the position of the pupil centers for primary gaze. Place a strip of scotch tape or mark a horizontal line 7mm below this point. Have the aviator recreate his or her seating position and control panel location to verify the segment height. As a final confirmation, if possible, have the aviator verify the marked spectacles in the cockpit. Seated comfortably in his or her normal configuration and looking outside the aircraft, the line or top of the tape should coincide with the top of the glare shield such that when the eyes rotate downward the front control panel area will be below the line or within the taped area. The aviator should be able to report whether the segment height is too high or too low and slight adjustments can be made to determine the proper segment height. Similar procedures are described in a U.S. Air Force report (Miller, Kent and Green, 1989). For safety reasons, this procedure should not be completed in flight.
5. General-use bifocal spectacles may be needed in addition to the "operationally-optimum spectacles."

## References

- Borish, I.M., ed. 1970. Clinical Refraction. Chicago, IL: Professional Press, p.178-184.
- Donders, F.C. 1864. On the anomalies of accommodation and refraction of the eye. The New Sydenham Society, London.
- Duane, A. 1909. The accommodation and Donders' curve and the need of revising our ideas regarding them. Journal of the American Medical Association. #52:1992-1996.
- Hamasaki, D. Ong, J. and Marg, E. 1956. The amplitude of accommodation in presbyopia. American Journal of Optometry and Archives of the American Academy of Optometry. #33:1, 3-14.
- Miller, R.E., Kent, J.F., and Green, R.P. 1989. Prescribing spectacle for aviators. Brooks Air Force Base, TX: U.S.A.F. School of Aerospace Medicine. USAFSAM-SR-89-5.
- Morgan, M.W. 1970. Accommodation and presbyopia. In: Borish IM. ed. Clinical Refraction. Chicago, IL: Professional Press, p.149-188.

Appendix A.

Summary table of the range of instrument distances and letter sizes.  
(Easy reference for clinicians)

**Summary Table of Instrument Distances and Letter Sizes**

<b>Type of Aircraft</b>	<b>Instrument at Primary Working distance</b>	<b>Overall Near range</b>	<b>Test letter size</b>
All aircraft	Approach plates	16-18in 41-46cm	20/30-20/40
All aircraft	Maps and charts	16-18in 41-46cm	20/25-20/40
AH-1S Cobra	Engine Panel (28-34in / 71-86cm)	17-35in 43-89cm	20/70
AH-64A Apache	Instrument Panel (33in / 84cm)	17-33in 43-84cm	20/70-100
RAH-66 Comanche	Dash Panel (26-32in / 66-81cm)	26-38in 66-97cm	not available
CH-47D Chinook	Instrument Panel (29in / 74cm)	15-44in 38-112cm	20/70-100
OH-58A/C Kiowa	Instrument Panel (29-31in / 74-79cm)	10.5-36in 27-91cm	20/70
OH-58D Kiowa Warrior	Instrument Panel (28-34in / 71-86cm)	17-36in 43-91cm	20/80-120
TH-67 Creek	Instrument Panel (26-29in / 66-74cm)	11-32in 28-81cm	20/70-100
UH-1H Iroquois	Front Console (32-41in / 81-104cm)	18-45in 46-114cm	20/70-100
UH-60A Blackhawk	Front Console (29-38in / 74-97cm)	18-44in 46-112cm	20/70
U-21A	Instrument Panel (26in / 66cm)	18-34in 46-86cm	20/70
C-12 Huron	Instrument Panel (33-43in / 84-109cm)	10-43in 25-109cm	20/60-150

Appendix B.

Letter type conversion chart.

As the Armed Forces Near Visual Acuity Test card contains both Jaeger paragraphs and Snellen letters, a conversion chart is given below:

<b>MIN ARC</b>	<b>LOG MAR</b>	<b>SNELLEN (feet)</b>	<b>SNELLEN (inches)</b>	<b>JAEGER (14 in.)</b>
0.50	-0.30	20 / 10		
0.75	-.01	20 / 15		
1.00	0.00	20 / 20	14 / 14	J 1+
1.30	0.10	20 / 25	14 / 17.5	J 1
1.50	0.18	20 / 30	14 / 21	J 2+
2.00	0.31	20 / 40	14 / 28	J 3-4
2.50	0.40	20 / 50	14 / 35	J 5
3.00	0.47	20 / 60	14 / 42	J 6
3.70	0.55	20 / 70	14 / 49	J 7
4.00	0.60	20 / 80	14 / 56	J 8
5.00	0.70	20 / 100	14 / 70	J 10
16.00	1.00	20 / 200	14 / 140	

## Appendix C.

### Army aircraft descriptions, instrument panel diagrams and measurements.

Note:

1) All distances have been carefully measured, but will vary depending upon aviator height and seat adjustment. The average variation is approximately  $\pm$  6-8 inches. All distances are given in inches except where noted.

2) Letter size was determined by comparing instrument letter size to the Armed Forces Near Visual Acuity Chart.

## AH-1S COBRA

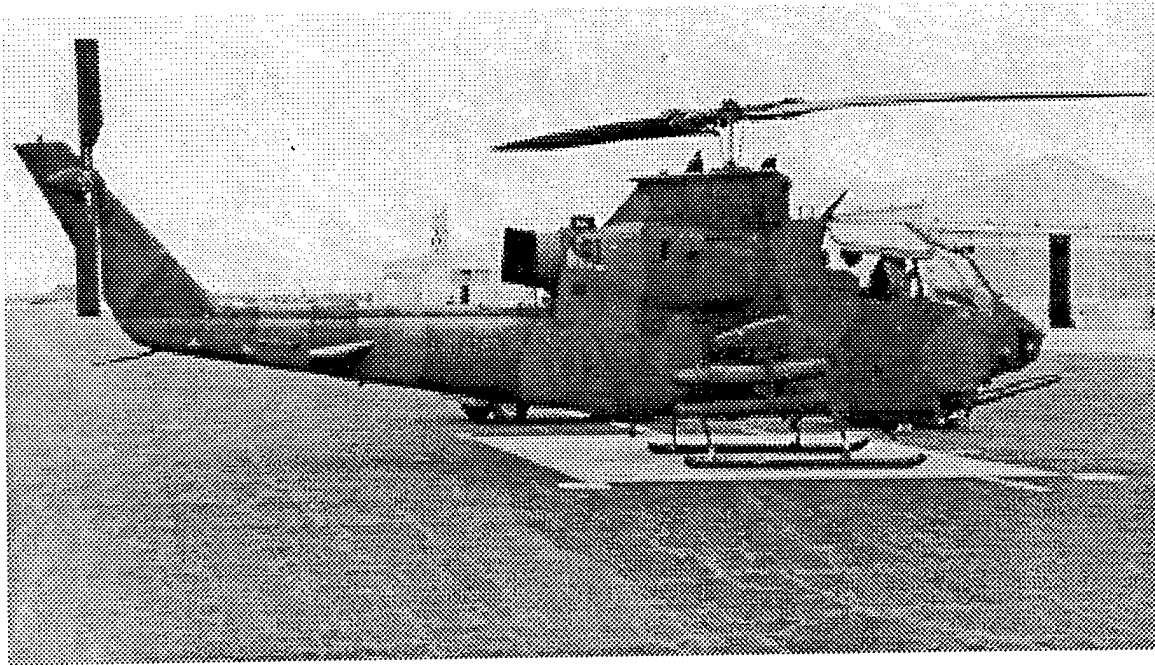

The AH-1S Cobra is equipped with a single turbine engine, two-bladed main and tail rotor, and an integral chin turret. With a seating capacity of two, it is used in support of military units as a combat gunship. Although its primary mission is anti-armor, the Cobra can be used in close air support and air-to-air roles. With a speed of 170 knots and a range of 410 kilometers, armament includes eight TOW missiles, two rockets, and one cannon. Weaponry configurations can, however, be modified for individual mission requirements. Furthermore, although the Cobra has a range of survivability equipment, it is not capable of flight under instrument meteorological conditions.

# AH-1S COBRA COCKPIT DESIGN

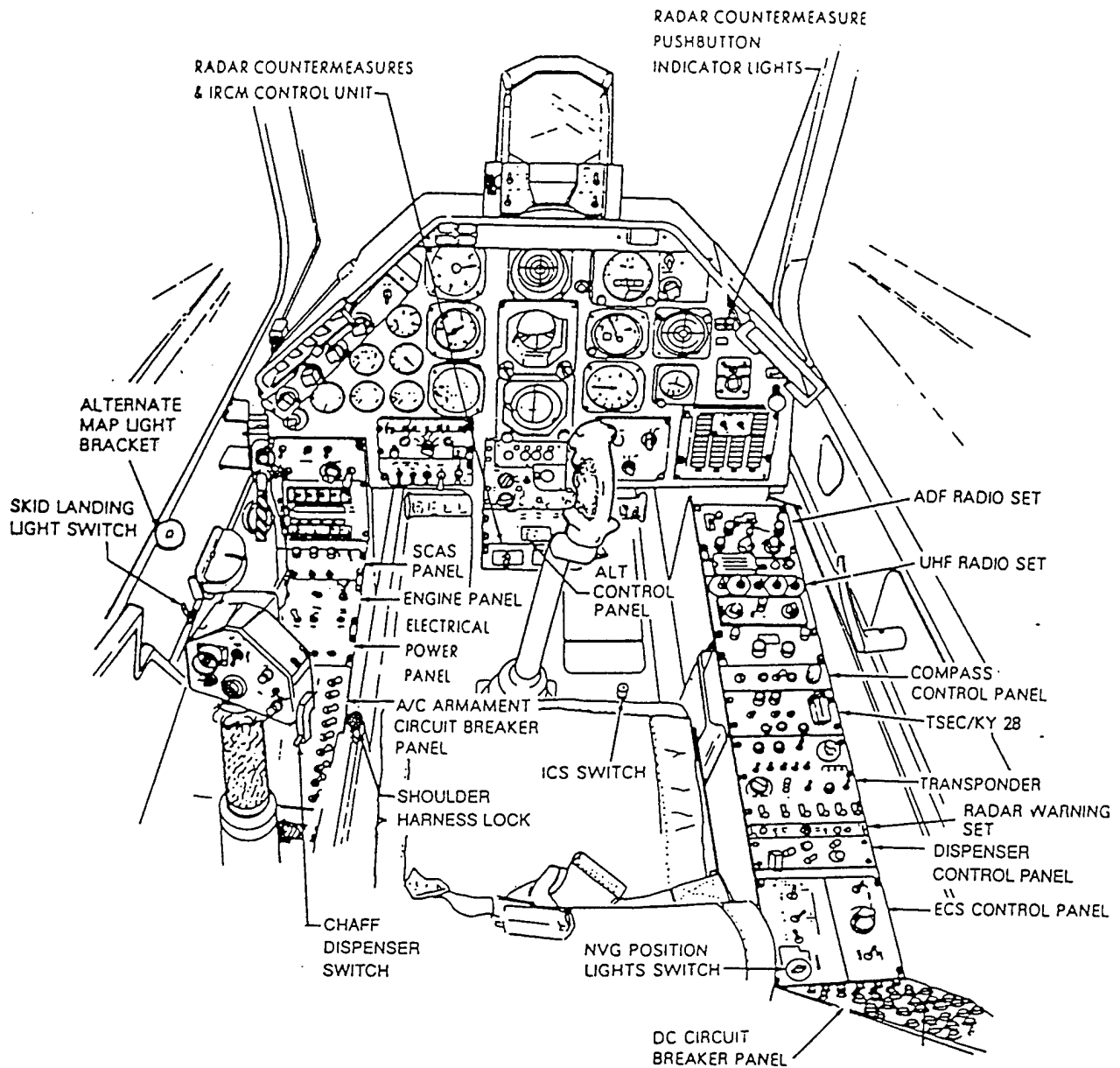

<u>Instrument</u>	<u>Distance (inches)</u>	<u>Snellen Nearpoint Chart</u>
T Sec/KY 28	24-35 (mean=27)	20/70
Engine Panel	28-34 (mean=31)	20/70-100
Front Center Console	28	20/70
DC Circuit Breaker Panel	17	20/70
Overhead Panel	31	20/70

## AH-64A/D APACHE

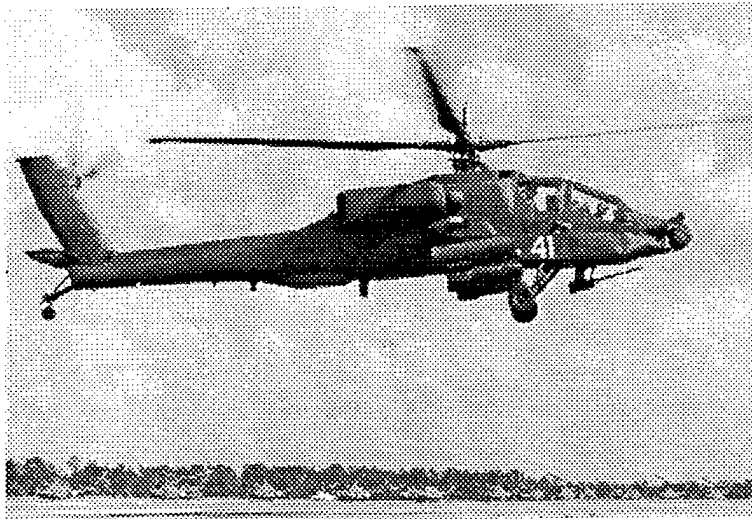

The Army's primary attack helicopter is the AH-64 Apache. Equipped with a front-drive turboshaft engine, it is a quick reacting, airborne antitank weapon. This helicopter can deploy quickly to the heaviest enemy penetration and delay, destroy, or disrupt the attack long enough for friendly ground maneuver units to reach the scene. The Apache is supplied with a Target Acquisition Designation Sight and Pilot Night Vision Sensor (TADS/PNVS) which permit its two-man crew to navigate and attack in darkness and in adverse weather conditions throughout the world. With a speed of 140 knots and a range of 690 kilometers, the Apache has a full range of aircraft survivability equipment and the ability to withstand hits from rounds up to 23mm caliber in critical areas.

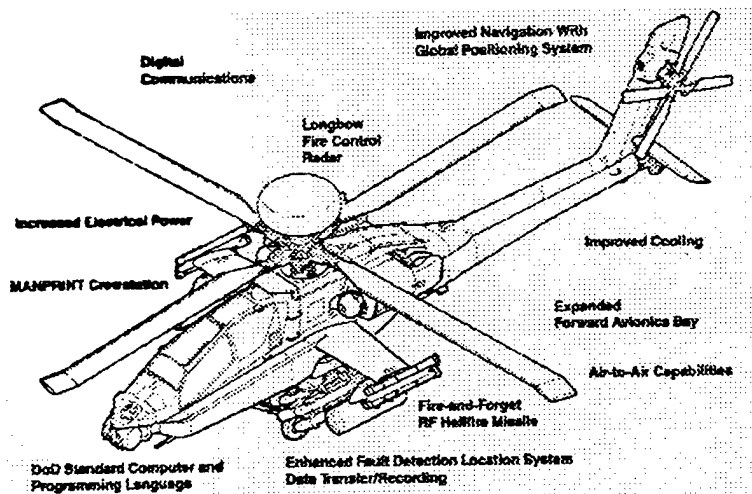

The AH-64D Apache Longbow is an improved variation of the AH-64A Apache aircraft modified to integrate the Longbow Radar with the Hellfire Missile System. Longbow is the result of a development and acquisition program for a millimeter wave radar air/ground targeting system capable of being used in day or night, in adverse weather, and through battlefield obscurants. Longbow's digitized target acquisition system will automatically locate, classify, prioritize and hand-off targets.

## AH-64A APACHE COCKPIT DESIGN

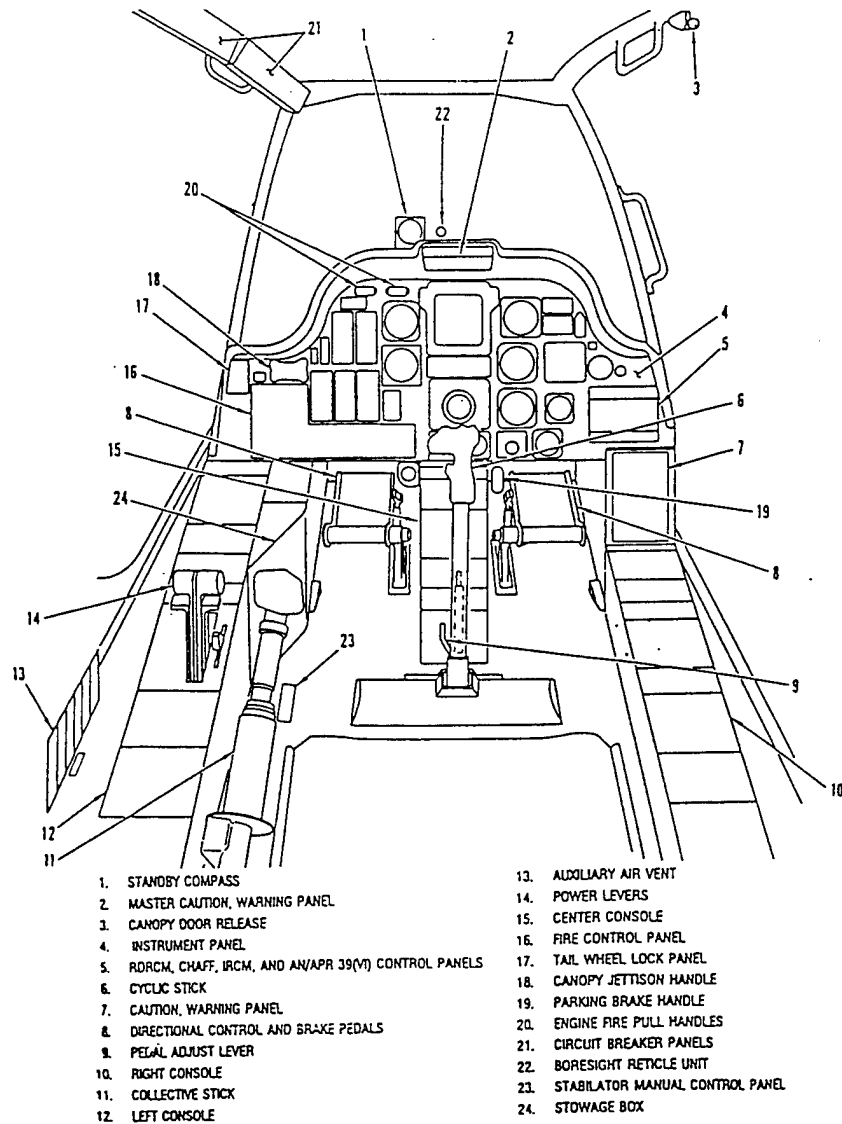

**Note:** This diagram represents the AH-64A cockpit layout. The dimensions for the AH-64D are not significantly different, however the nearpoint demand depends on the digital display characteristics.

<u>Instrument</u>	<u>Distance (inches)</u>	<u>Snellen Nearpoint Chart</u>
Center Front Console	27	20/70
Instrument Panel	33	20/70-100
Cyclic Stick	21	20/70-100
Left Console	31.5-33	20/70-100
Center Left Console	27	20/70-100
Circuit Breaker Panel	17-29 (mean=21)	20/70

## RAH-66 COMANCHE



The RAH-66 Comanche (Light Helicopter (LH) developmental) is the Army's next generation helicopter. Designed for use by two rated-aviator crewmembers, the Comanche will be capable of performing attack missions and armed reconnaissance, both of which encompass an embedded air combat capability. This helicopter will be capable of conducting tactical day/night operations in all types of terrain. Increased active and passive survivability performance will enhance combat operation and mission accomplishment. Its 1260 nautical mile self-deployment range and smaller size, compared to the AH-64, will improve Army aviation's rapid strategic deployment. The RAH-66 is expected to be fielded in 2006.

**Note:** As of September 1999, the Comanche had not yet reached its final design stage. Therefore, a diagram of the cockpit configuration was not available and instrument distances were those noted in the design specifications.

<u>Instrument</u>	<u>Distance(inches)</u>	<u>Snellen Nearpoint Chart</u>
Front Seat:		
Dash Panel	30-32	information currently not available
Left Side Console	31-38	
Right Side Console	30	
Back Seat:		
Dash Panel	26-28	
Left Side Console	31-38	
Right Side Console	30	

## CH-47D CHINOOK



The CH-47D Chinook is equipped with two three-bladed counter-rotating main rotors (one aft and one fore), two shaft-turbine engines, and fixed landing gear. Two pilots and a flight engineer are the minimum crew necessary to fly this helicopter whose seating capacity is 33 to 37 soldiers or 24 litter patients with 2 medical attendants. With a speed of 150 knots and 470 kilometer range, the Chinook is used mainly as a troop/cargo transport with the additional capability to land on water when needed. Although armament varies, available subsystems include machine guns.

## CH-47D CHINOOK COCKPIT DESIGN

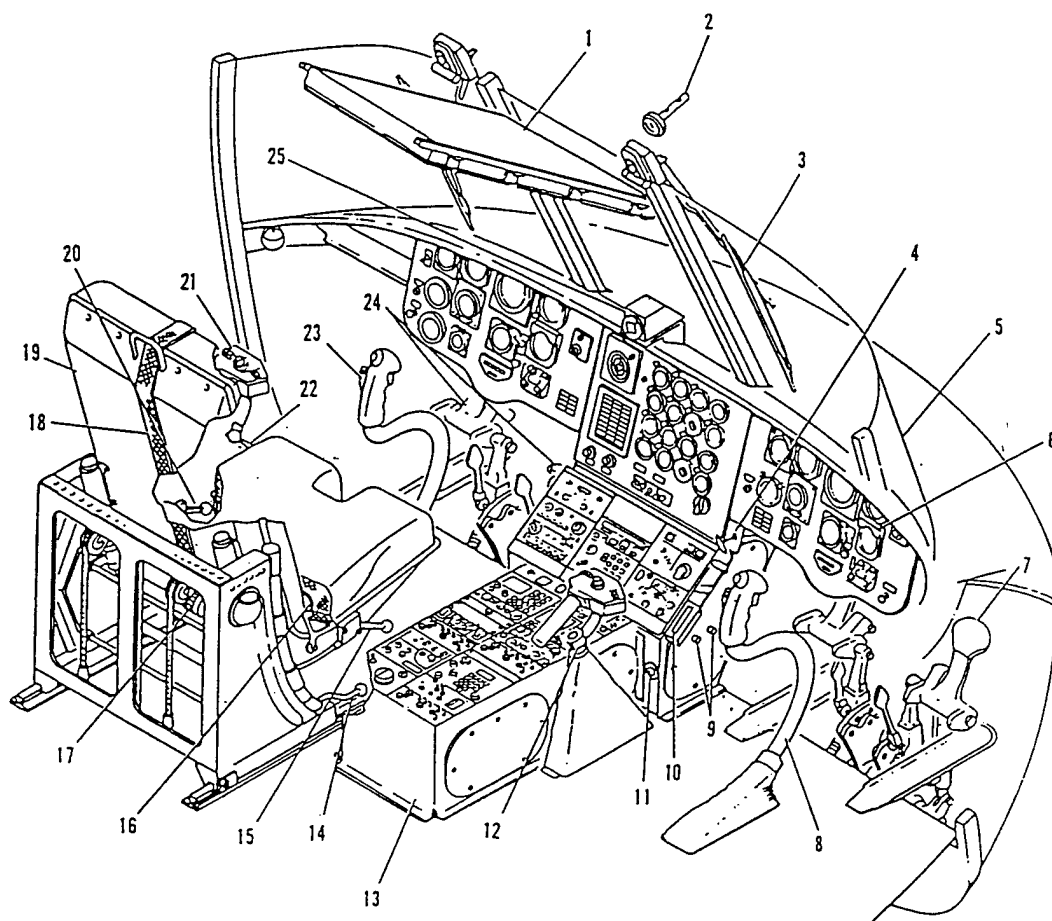

- |   |   |  |
|---|---|--|
| <ul style="list-style-type: none"> <li>1. Overhead switch panel</li> <li>2. Free air temperature gauge</li> <li>3. Windshield wiper</li> <li>4. Parking brake handle</li> <li>5. Windshield</li> <li>6. Instrument panel</li> <li>7. Pilot wheel brakes and directional pedals</li> <li>8. Pilot cyclic stick</li> <li>9. Topping stop studs</li> </ul> | <ul style="list-style-type: none"> <li>10. Longitudinal stick position indicator</li> <li>11. Ignition lock switch</li> <li>12. Pilot THRUST CONT (control) lever</li> <li>13. Center console</li> <li>14. Horizontal seat adjustment lever</li> <li>15. Vertical seat adjustment lever</li> <li>16. Safety belt</li> <li>17. Inertia reel</li> <li>18. Shoulder harness</li> </ul> | <ul style="list-style-type: none"> <li>19. Seat</li> <li>20. Rotational adjustment lever</li> <li>21. Copilot THRUST CONT (control) lever</li> <li>22. Inertia reel lock</li> <li>23. Copilot cyclic stick</li> <li>24. Copilot wheel brakes and directional pedals</li> <li>25. Magnetic compass</li> </ul> |
|---|---|--|

<u>Instrument</u>	<u>Distance (inches)</u>	<u>Snellen Nearpoint Chart</u>
Overhead Panel	15-30 (mean=21)	20/70-100
Front Console	44	20/70-100
Instrument Panel	29	20/70-100
Pedestal Console	31-42 (mean=34)	20/70

## OH-58A/C KIOWA

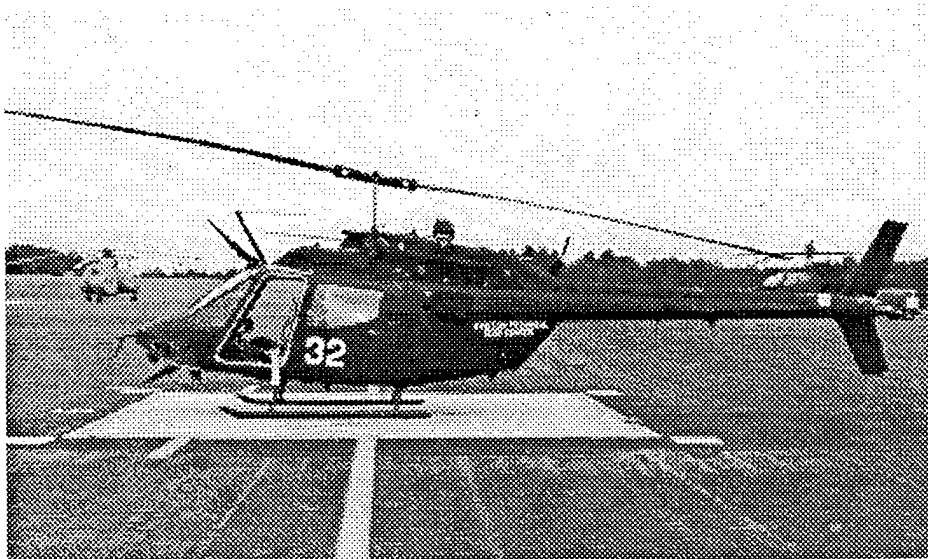

The OH-58A/C Kiowa is a two-bladed main and tail rotor helicopter. Its single turbine engine permits a speed of 120 knots and a range of 416 kilometers. With a seating capacity from one to four, the helicopter offers varied armament. Although its primary mission is in light observation and reconnaissance as a scout aircraft, it can be equipped with armor for combat operations. The OH-58A can incorporate an armament subsystem which, among other equipment, includes a machine gun. The C model can be supplied with the Stinger missile system for the engagement of hostile aircraft in a combat area. The OH-58A and C models are primarily found in Reserve and National Guard units.

## OH-58A/C KIOWA COCKPIT DESIGN

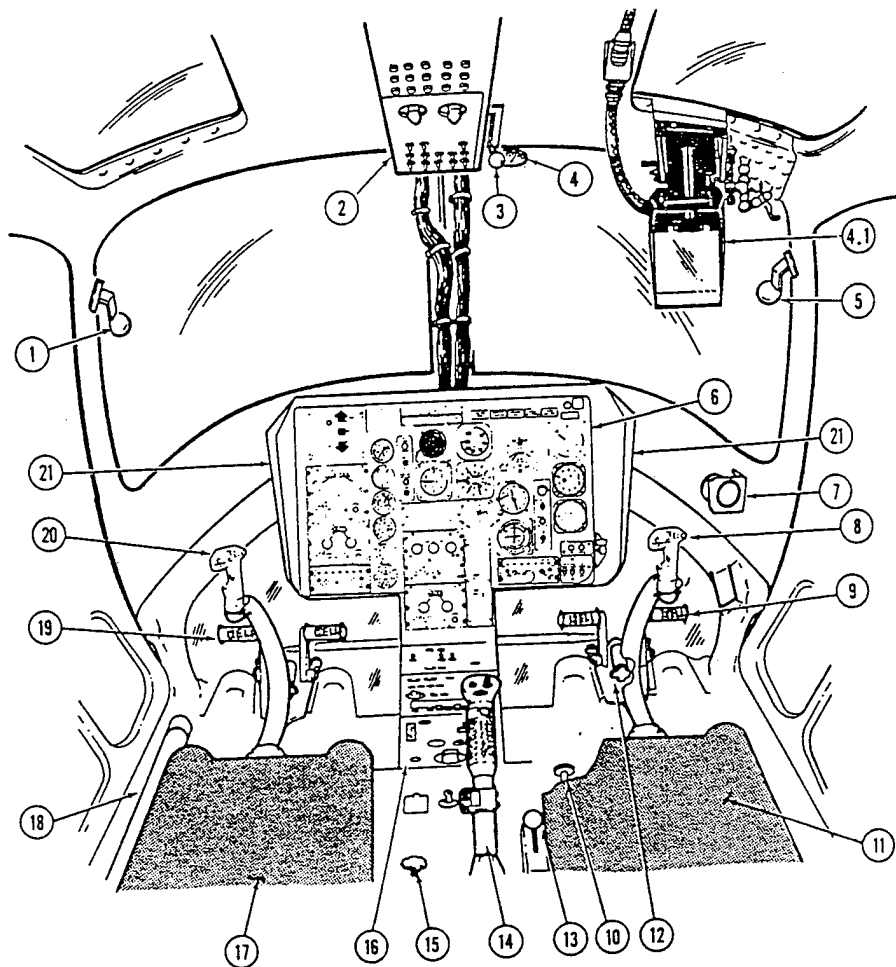

- |   |  |
|---|--|
| <ul style="list-style-type: none"> <li>1. Copilot Door Emergency Jettison Handle</li> <li>2. Overhead Console</li> <li>3. Fuel ON/OFF Control Handle</li> <li>4. Free Air Temperature (FAT) Gage</li> <li>4.1. Pilot Display Unit (PDU)</li> <li>5. Pilot Door Emergency Jettison Handle</li> <li>6. Instrument Panel</li> <li>7. Magnetic Compass</li> <li>8. Pilot Cyclic Stick</li> <li>9. Pilot Anti-Torque Pedals</li> <li>10. Cyclic Friction Control Adjustment</li> </ul> | <ul style="list-style-type: none"> <li>11. Pilot Seat</li> <li>12. Anti-Torque Pedal Adjuster</li> <li>13. Shoulder Harness Lock</li> <li>14. Pilot Collective Lever</li> <li>15. Collective Friction Control Adjustment</li> <li>16. Console</li> <li>17. Copilot/Observer Seat</li> <li>18. Copilot Collective Lever</li> <li>19. Copilot Anti-Torque Pedals</li> <li>20. Copilot Cyclic Stick</li> <li>21. Glareshield</li> </ul> |
|---|--|

Instrument	Distance (inches)	Snellen Nearpoint Chart
Overhead Console	10.5-22 (mean=15)	20/70
Copilot Door Emergency Jettison Handle	31	20/70
Instrument Panel	29-31	20/70
Pedestal Console	31-36	20/70

## OH-58D KIOWA WARRIOR

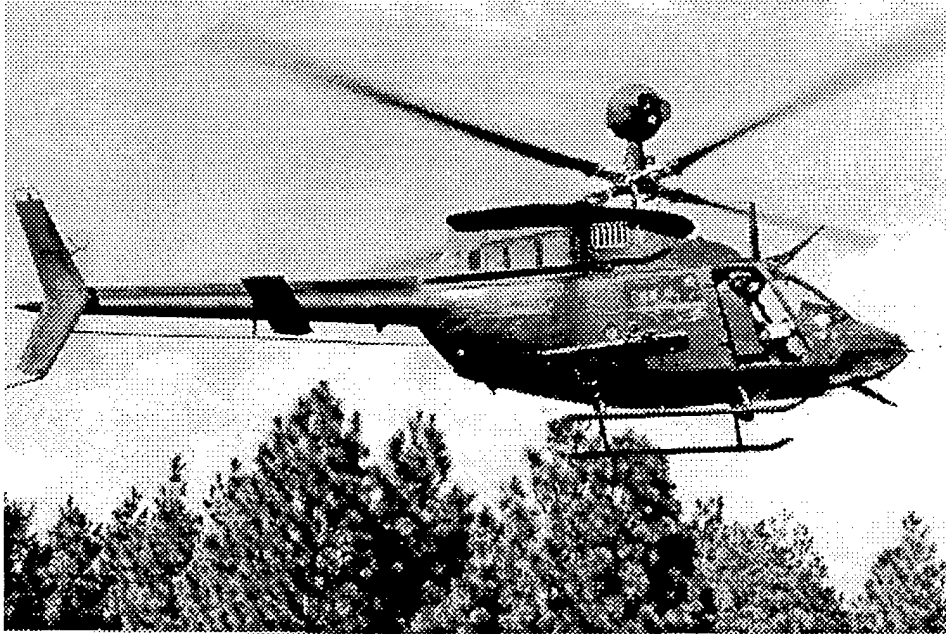

The Army's first true scout helicopter is the OH-58D Kiowa Warrior. Equipped with a single turboshaft engine, distinguishable features include a four-bladed main and two-bladed tail rotor, and a mast mounted sight above the main rotor. The mast mounted sight enables the mission to be accomplished while at a stand-off range and out of direct line of sight of enemy observation. With seating for two, the Kiowa is used in target acquisition, close combat aerial reconnaissance, surveillance, and intelligence gathering. Precise target location information can then be handed off to other aircraft or artillery elements via an airborne target handover system. Furthermore, a laser designator enables the helicopter to provide designation for laser guided weapons. Armament for the Kiowa Warrior includes the Stinger missile.

# OH-58D KIOWA WARRIOR COCKPIT DESIGN

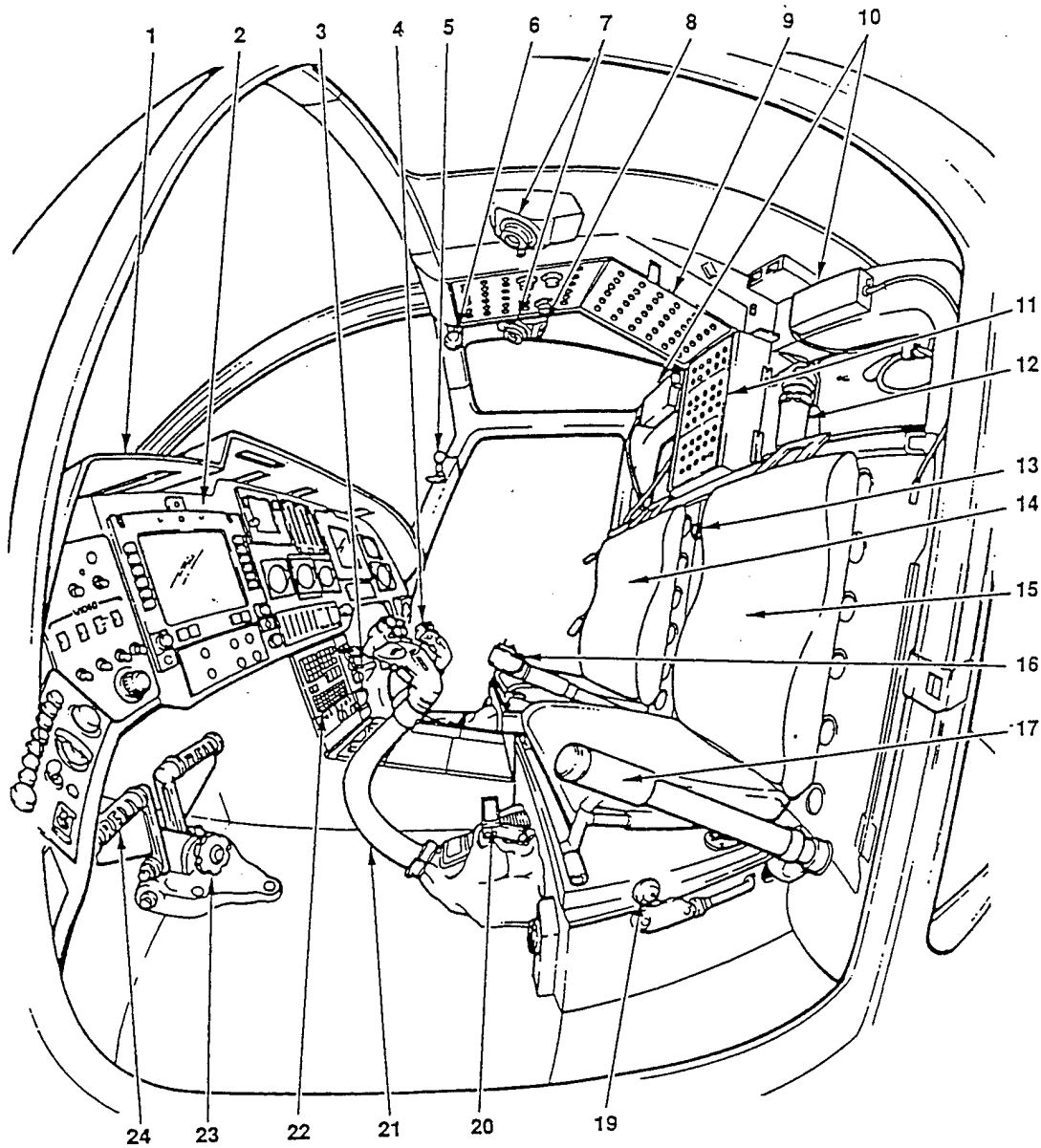

1. Glare shield
2. Instrument panel
3. Pilot antitorque pedals
4. Pilot cyclic stick
5. Pilot door jettison lever
6. Fuel shutoff lever
7. Floodlights
8. Battery preheat indicator lights

9. Overhead console
10. NVG power converter
11. Center post console
12. Fire extinguisher
13. Utility light
14. Pilot seat
15. CPO seat
16. Pilot collective

17. CPO collective
18. Deleted
19. CPO shoulder harness lock
20. CPO cyclic lockout handle
21. CPO cyclic stick
22. Pedestal console
23. CPO antitorque pedal adjustment knob
24. CPO antitorque pedals

Instrument	Distance (inches)	Snellen Nearpoint Chart
Instrument Panel	28-34 (mean=31)	20/80-120
Overhead Console	17-18	20/100
Center Post Console	32-36	20/80

## TH-67 CREEK



The TH-67 Creek (Bell 206B III) is a single engine, utility helicopter with the primary mission of training, both VFR and IFR. The standard configuration provides for three crashworthy seats for one pilot/student, one instructor pilot/copilot, and one observer. With its design as a training helicopter, it is relatively small, with a maximum gross weight of only 3,200 pounds and a maximum airspeed of 130 knots (below 3,000 feet pressure altitude). It is designed to take-off and land on reasonably level terrain, utilizing standard skid type landing gear, and has all-weather capability (in the Instrument configuration). Service ceiling is up to 14,000 feet IFR or 20,000 feet VFR (at 3,000 pounds gross weight or below).

## TH-67 CREEK COCKPIT DESIGN

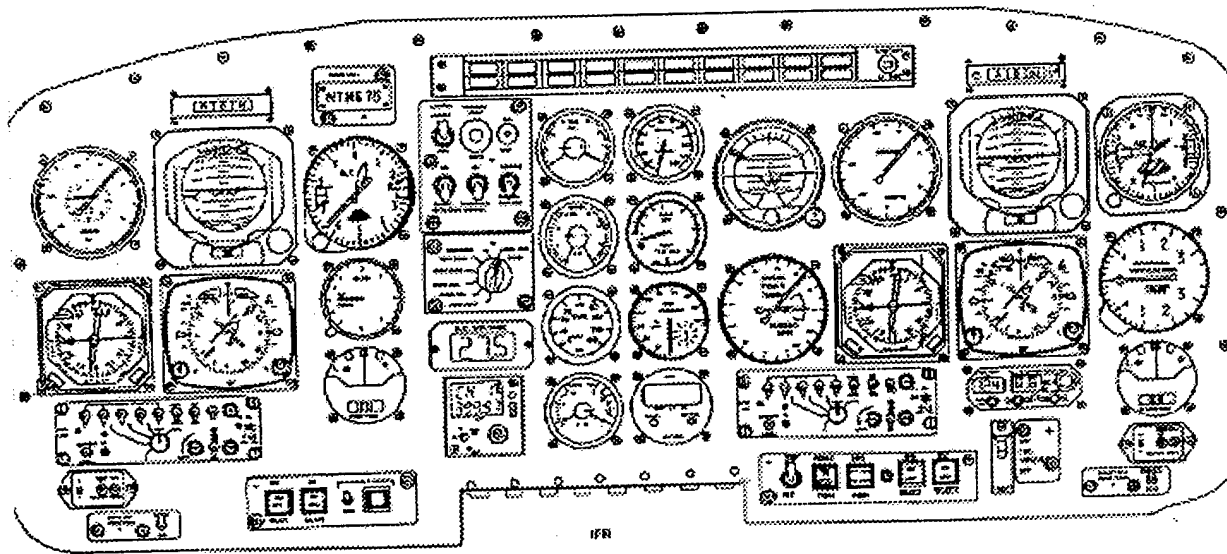

<u>Instrument</u>	<u>Distance (inches)</u>	<u>Snellen Nearpoint Chart</u>
Instrument Panel	26-29	20/70
Center Pedestal	30-32	20/100
Overhead Control Panel	11-15	20/70

## UH-1H IROQUOIS



The UH-1H Iroquois, better known as the Huey, was the most widely used military helicopter between 1963 and 1986. It is a single engine, two-bladed main and tail rotor helicopter. The UH-1 engine permits a 90-knot airspeed and a range of 340 kilometers. The minimum crew necessary to fly the helicopter is one pilot. Additional crewmembers such as a copilot or crew chief may be added at the discretion of the commander. The personnel compartment provides seating for up to eleven combat equipped troops or up to six patients. Available armament includes two machine guns with weapon ranges of 1,100 meters. The UH-1 is employed in support of military units with primary use in troop assault and general cargo transport.

## UH-1H IROQUOIS COCKPIT DESIGN

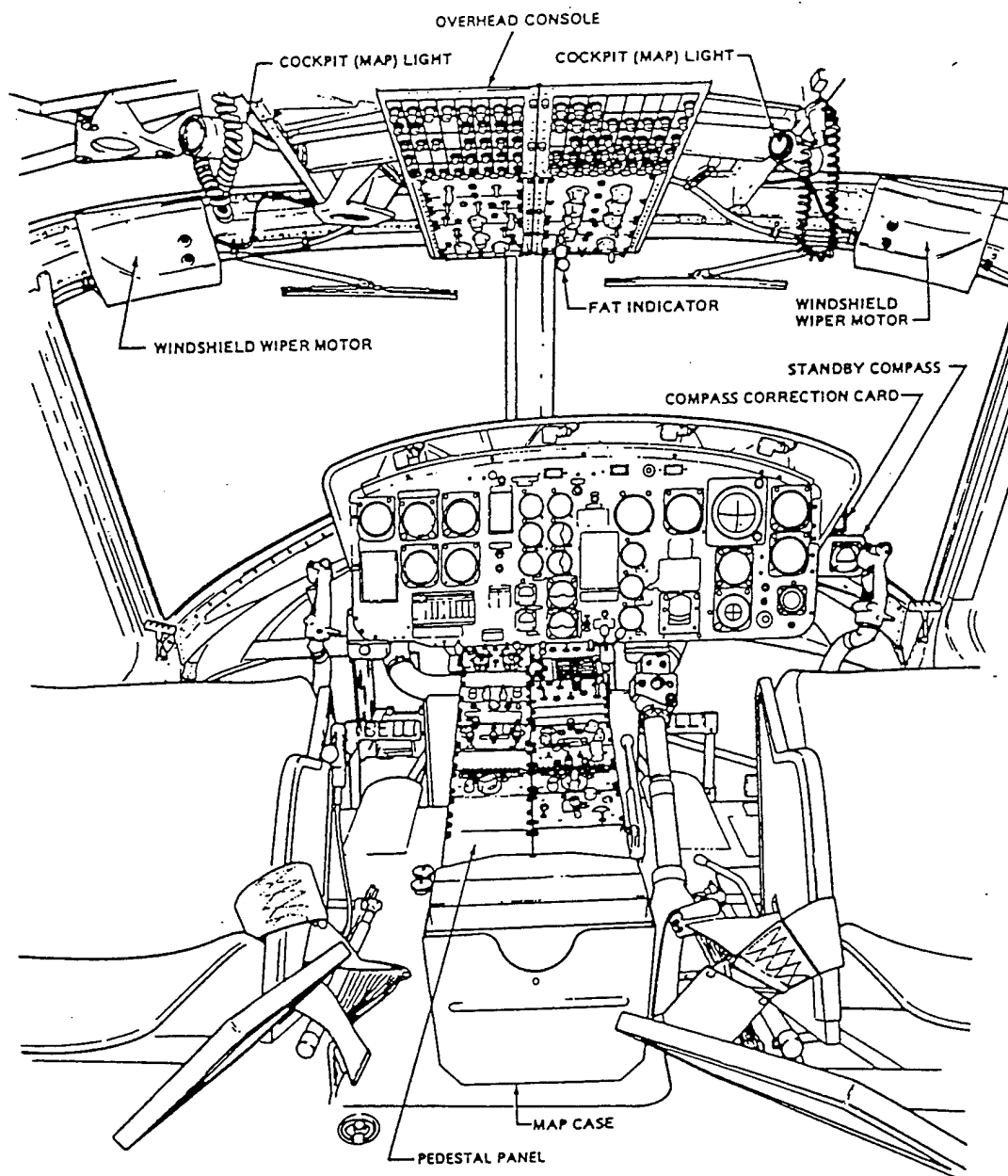

<u>Instrument</u>	<u>Distance (inches)</u>	<u>Snellen Nearpoint Chart</u>
Overhead Panel	18-30 (mean=24)	20/60-70
Front Console	32-41	20/70
Pedestal Panel	37-45	20/70-100

## UH-60 SERIES BLACKHAWK



The UH-60 series Blackhawk is the primary division-level assault and transport helicopter providing dramatic improvements in troop capacity and cargo lift capability compared to the UH-1 series Huey it replaced. The Blackhawk is a twin turbine engine, single rotor helicopter. With a crew of three, it carries 11 combat-equipped troops with optional seating for 14 arranged in various configurations, as well as internal and external cargo. The Blackhawk's range is 578 kilometers, whereas its speed is 142 knots. Primary mission capability of the helicopter is tactical transport of troops, supplies and equipment. Secondary missions entail training, mobilization, development of new and improved concepts, medical evacuation, and support of disaster relief. Armament includes two machine guns with weapon ranges of 1,100 meters.

## UH-60A BLACKHAWK COCKPIT DESIGN

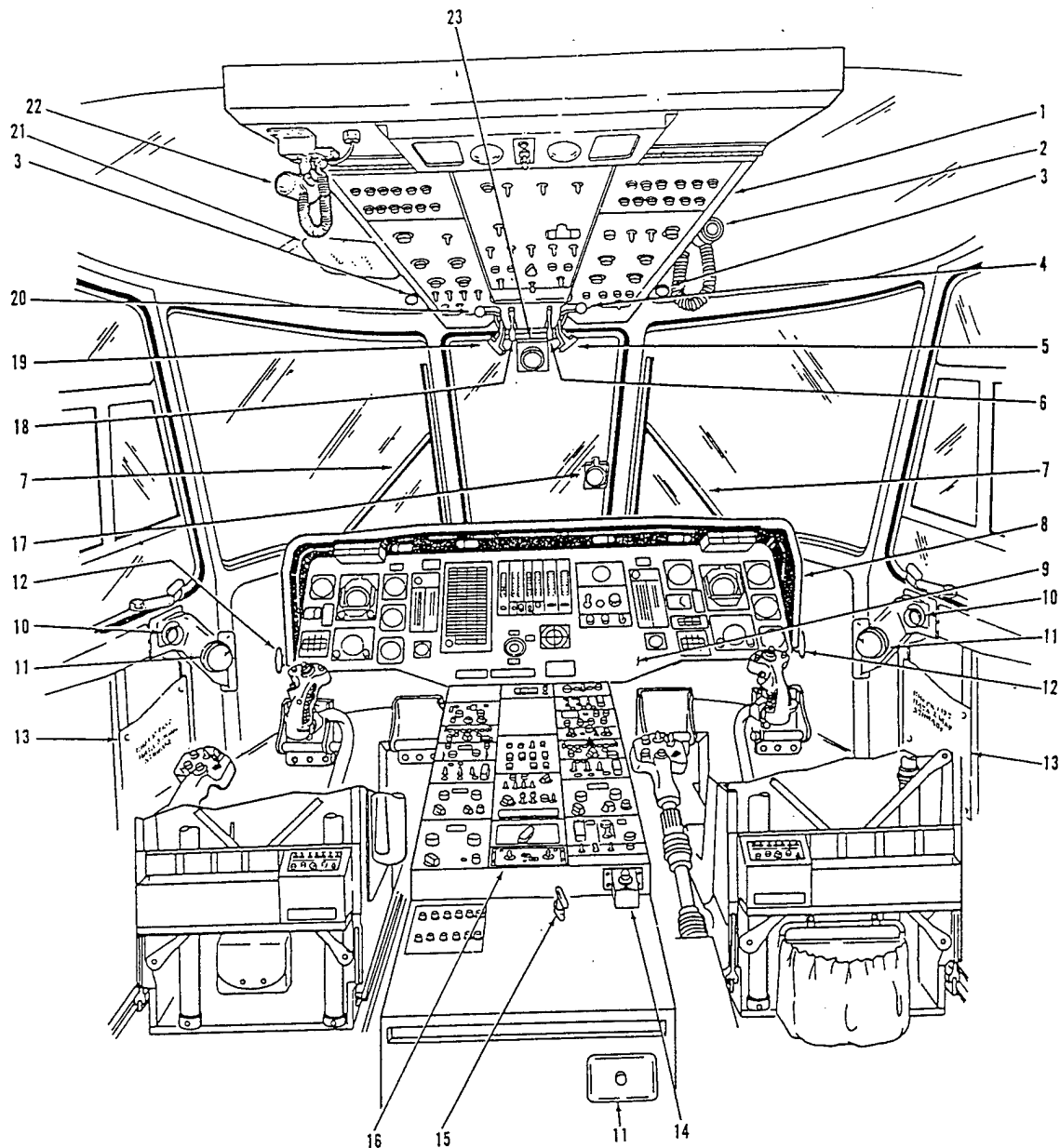

- 1 UPPER CONSOLE
- 2 PILOT'S COCKPIT UTILITY LIGHT
- 3 FREE-AIR TEMPERATURE GAGE (ON HELICOPTERS WITH HEATED CENTER WINDSHIELD)
- 4 NO. 2 ENGINE FUEL SELECTOR LEVER
- 5 NO. 2 ENGINE OFF/FIRE T-HANDLE
- 6 NO. 2 ENGINE POWER CONTROL LEVER
- 7 WINDSHIELD WIPER
- 8 INSTRUMENT PANEL GLARE SHIELD

- 9 INSTRUMENT PANEL
- 10 VENT/DEFOGGER
- 11 ASHTRAY
- 12 PEDAL ADJUST LEVER
- 13 MAP/DATA CASE
- 14 CHAFF RELEASE SWITCH
- 15 PARKING BRAKE LEVER
- 16 FUEL BOOST PUMP PANEL
- 17 STANDBY (MAGNETIC COMPASS)

- 18 NO. 1 ENGINE POWER CONTROL LEVER
- 19 NO. 1 ENGINE OFF/FIRE T-HANDLE
- 20 NO. 1 ENGINE FUEL SELECTOR LEVER
- 21 AC ESNTL BUS CIRCUIT BREAKER PANEL
- 22 COPILOT'S COCKPIT UTILITY LIGHT
- 23 FREE-AIR TEMPERATURE GAGE (ON HELICOPTERS WITHOUT HEATED CENTER WINDSHIELD)

<u>Instrument</u>	<u>Distance (inches)</u>	<u>Snellen Nearpoint Chart</u>
Overhead Panel	18-36 (mean=27)	20/70
Front Console	29-38	20/70
Pedestal Panel	32.5-44 (mean=37)	20/70

## U-21A



The U-21A is a low wing, unpressurized, all metal aircraft, powered by two turboprop engines. It has all-weather capability and requires a minimum crew of one pilot for normal aircraft operation. The U-21's 6 to 10 troop seats can be folded to create unrestricted space for cargo. The utility aircraft functions in various roles, to include use as an air ambulance. Armament, however, is not included in the U-21's equipment inventory.

## U-21A COCKPIT DESIGN

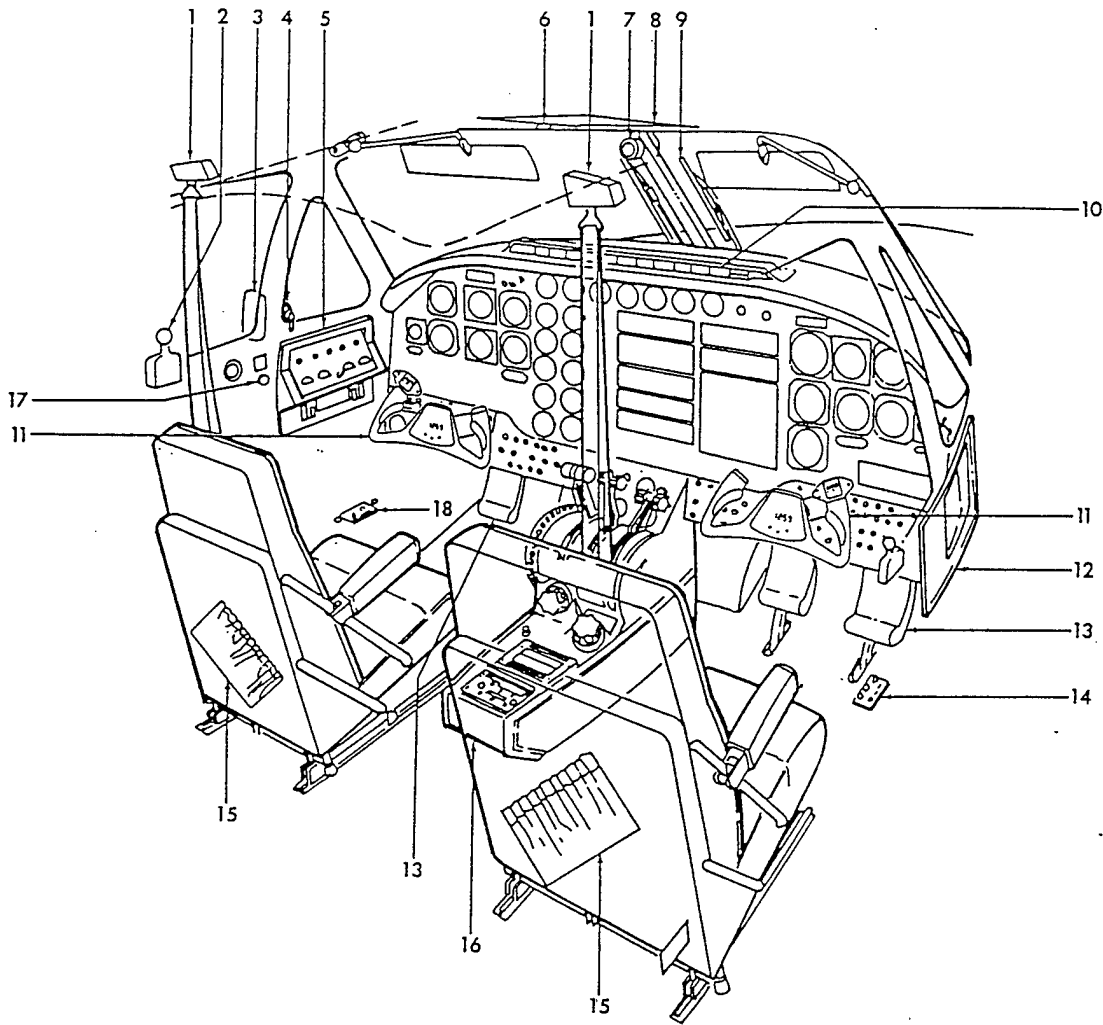

1. Shoulder harness inertia reel
2. Should harness lock levers
3. Rear view mirror
4. Storm window lock
5. Fuel management panel
6. Free air temperature gage
7. Magnetic compass
8. Overhead control panel
9. Windshield wipers

10. Annunciator panel
11. Control wheels
12. Copilot's circuit breaker and fuse panel
13. Rudder pedals
14. Copilot's oxygen regulator control panel
15. Utility pockets
16. Control pedestal
17. Rear view mirror control knob
18. Pilot's oxygen regulator control panel

<u>Instrument</u>	<u>Distance (inches)</u>	<u>Snellen Nearpoint Chart</u>
Instrument Panel	26	20/70
Front Console	30	20/70-100
Center Pedestal	29-34	20/70
Fuel Management Panel	20-26	20/70
Overhead Control Panel	18-29 (mean=22)	20/70
Control Wheels	21	20/70-100
Copilot's Circuit Breaker and Fuse Panel	18	20/70

## C-12 HURON

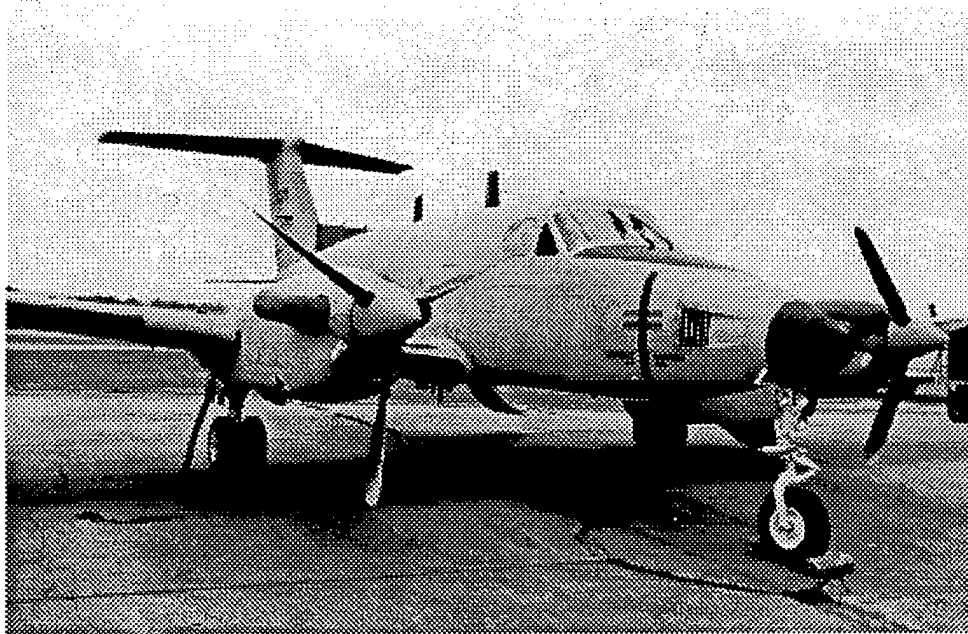

The C-12 Huron is a low-wing, pressurized all metal fixed wing aircraft with all-weather capability. Powered by two turboprop engines, distinguishable features include four-bladed propellers and a T-tail. The C-12 is used as a passenger or cargo aircraft as well as having the capability of being configured for other types of specialized missions. It is not, however, equipped with armament. Another version of this aircraft is the RC-12K. In addition to its basic cargo mission, the RC-12K's modified mission is reconnaissance. Survivability equipment for the K model includes effective countermeasures against radar guided weapons systems and infrared seeking missile threats.

## C-12 HURON COCKPIT DESIGN

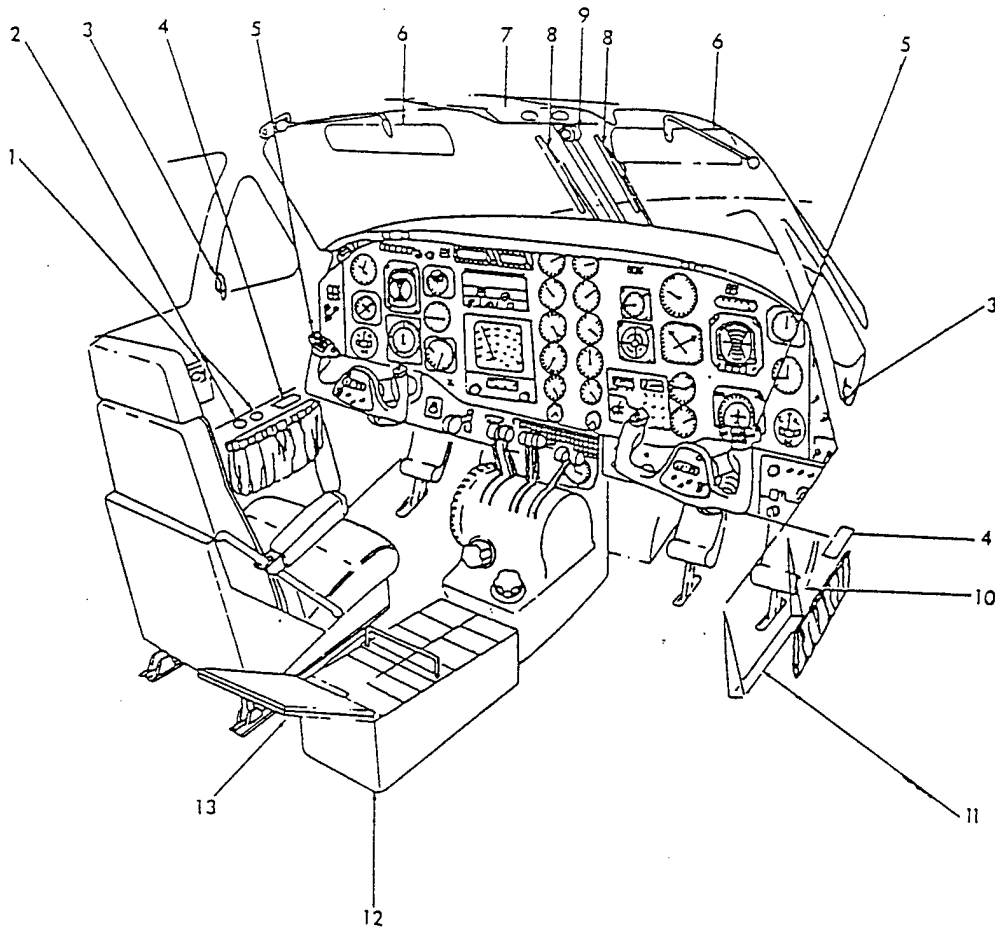

- |  |   |
|--|---|
| <ol style="list-style-type: none"> <li>1. Free Air Temperature Gage</li> <li>2. Oxygen System Pressure Gage</li> <li>3. Storm Window Lock</li> <li>4. Oxygen Regulator Control Panel</li> <li>5. Control Wheel</li> <li>6. Sun Visor</li> <li>7. Overhead Circuit Breaker and Control Panel</li> </ol> | <ol style="list-style-type: none"> <li>8. Windshield Wiper</li> <li>9. Magnetic Compass</li> <li>10. Rudder Pedals</li> <li>11. Mission Control Panel</li> <li>12. Pedestal Extension</li> <li>13. Assist Step</li> </ol> |
|--|---|

Note: Copilot seat removed for clarity

Instrument	Distance (inches)	Snellen Nearpoint Chart
Instrument Panel	33-43	20/60-150
Overhead		
Back	10-25	20/80
Middle	14-25	20/80
Front	19-25	20/100
Pedestal	35	20/80-150