

Workshop
Future Directions in Systems and
Control Theory

Friday , June 25

Viewgraphs - Volume 4

DISTRIBUTION STATEMENT A
Approved for Public Release
Distribution Unlimited

20000118 126

Workshop On

FUTURE DIRECTIONS IN SYSTEMS AND CONTROL THEORY

NEW PROBLEMS AND METHODS
IN THE CONTROL OF
PHYSICAL SYSTEMS

Cascais, Portugal
June 22-25, 1999

Roger Brockett
June, 1999

The Outline

1. Elastic Networks (*micro-machines*)
2. Electrostatically Driven Elastic Networks
3. Piezoelectrically Driven Elastica
4. Actuators
5. Models for Hysteresis
6. Nonlinear Oscillatory Effects

Elastic Networks

Bending beam equation relates the curvature and the moment

$$\kappa = \frac{M}{EI}$$

E = Young's modulus, I = second moment of area.

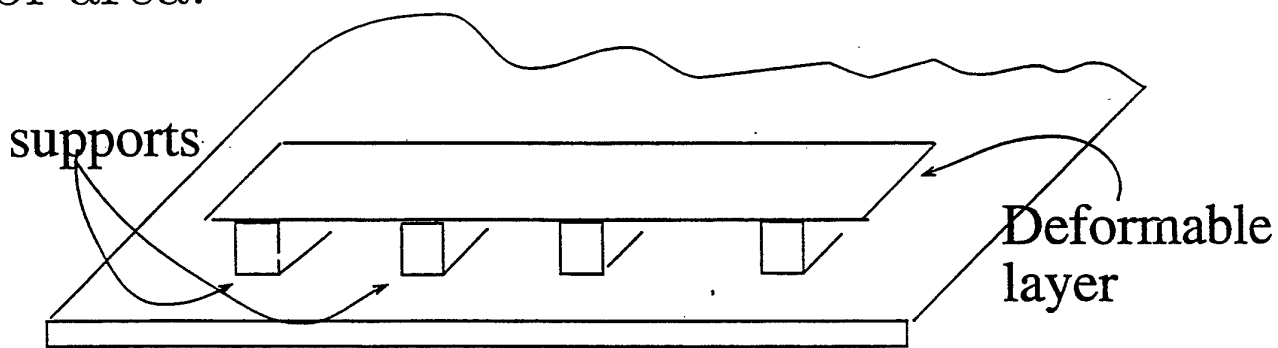

Structures tend to be complex with many loops and few (if any) "pin joints".

Flexures are easier to fabricate than bearings. (Later discussion of valves, arrays of mirrors, ...)

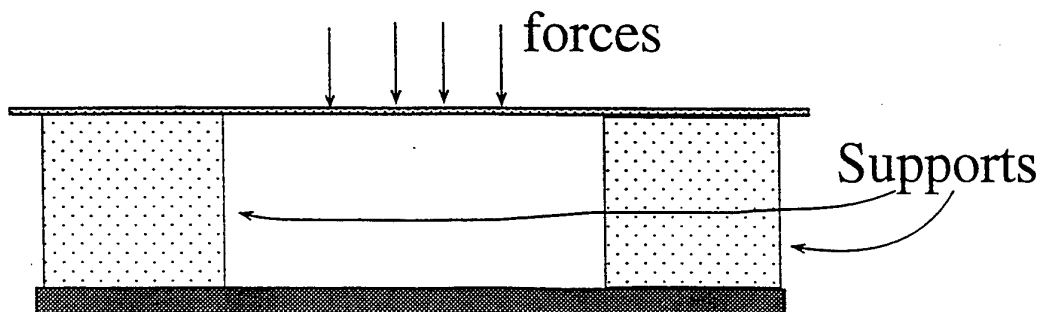

Interpreting Some Basic Physics

Stored energy in terms of capacitance and voltage or charge: $E = \frac{1}{2}Ce^2 = \frac{1}{2C}q^2$

$C = A\epsilon/d$ for parallel plate capacitor.

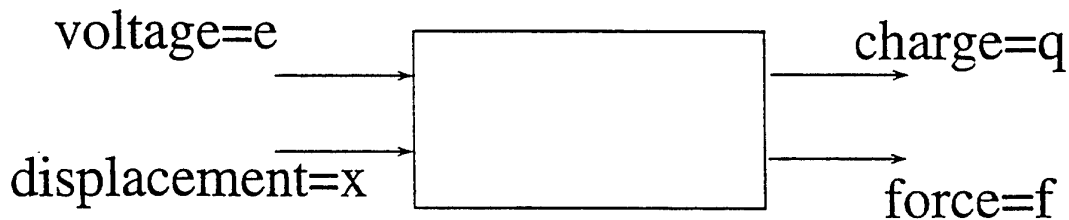
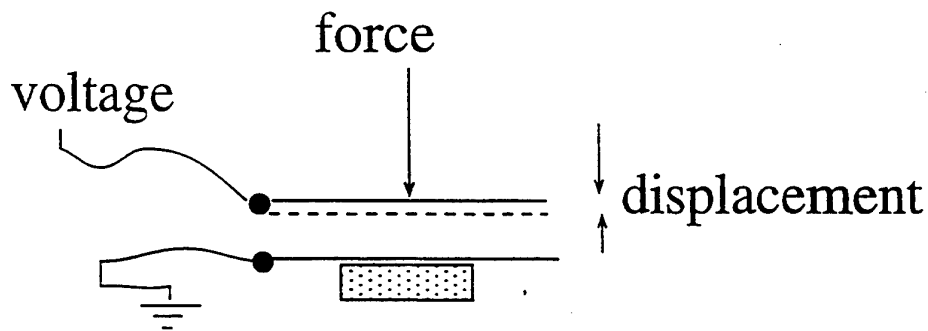

Linearizing about (e_0, x_0)

$$\begin{bmatrix} \delta q \\ \delta f \end{bmatrix} = \begin{bmatrix} C(x_0) & \frac{\partial C}{\partial x} e_0 \\ \frac{\partial C}{\partial x} e_0 & \frac{1}{2} \frac{\partial^2 C_0}{\partial x^2} e_0^2 \end{bmatrix} \begin{bmatrix} \delta e \\ \delta x \end{bmatrix}$$

importance of off-diagonal terms

Electrostatic Motors

One way in which electrostatic and elastic effects have been combined in devices is in the design of tuning forks. The diagram below illustrates a sample design for an electrically driven vibrating element.

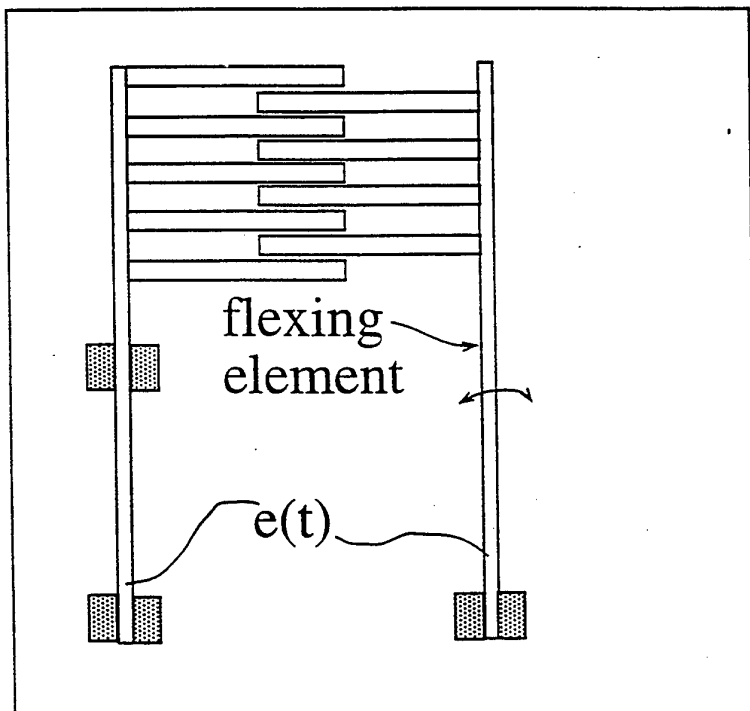

The force on the vibrating element can be determined from the derivative of the capacitance

Electrostrictive Stacks

Uses high permittivity dielectric thus yielding large values for C and $\frac{\partial C}{\partial x}$

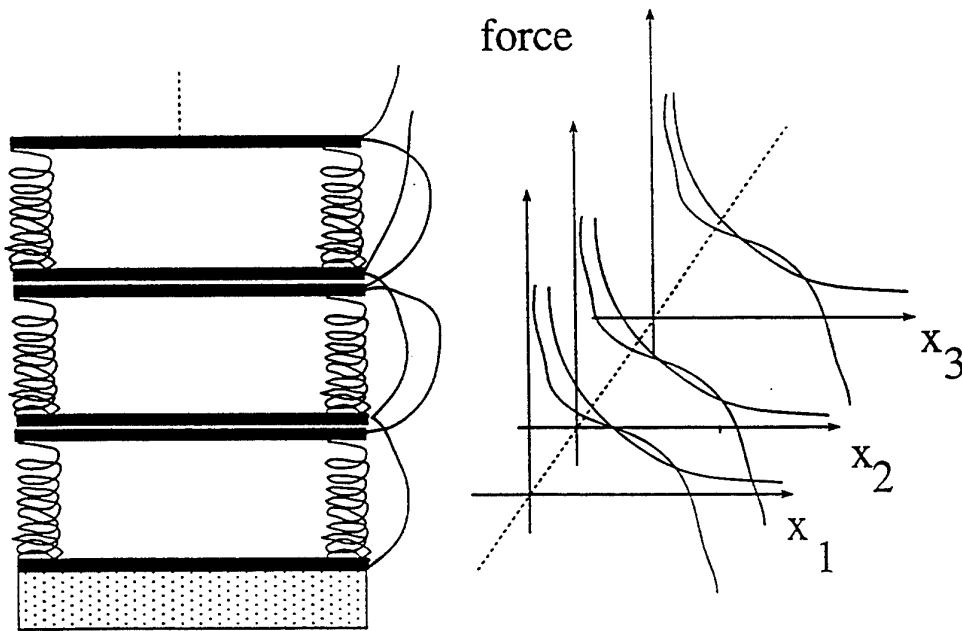

Inserting insulating layers permits the use of lower voltages for reasonable strains.

Illustrating the possibility of multiple equilibria and the basis of hysteresis.

Electric and Elastic Effects

The plates of the capacitor will be held in position by a system with mechanical compliance.

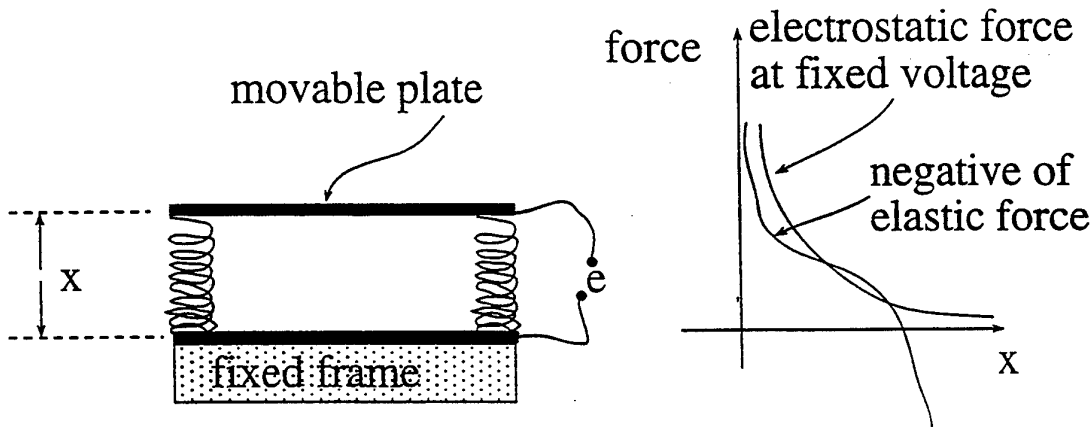

$$\begin{bmatrix} \delta q \\ \delta f \end{bmatrix} = \begin{bmatrix} C(x_0) & \frac{\partial C}{\partial x} e_0 \\ \frac{\partial C}{\partial x} e_0 & k(x_0) + \frac{1}{2} \frac{\partial^2 C_0}{\partial x^2} e_0^2 \end{bmatrix} \begin{bmatrix} \delta e \\ \delta x \end{bmatrix}$$

Electrostatic force falls off with increasing x . Note the possibility of multiple equilibria even if the elastic law is linear. Some will be unstable.

Introducing Dynamics

Lagrangian depends on electrostatic energy V and elastic energy E

$$L(\dot{x}, x) = \frac{1}{2}m\dot{x}^2 - \frac{1}{2}C(x)e^2 - E(x)$$

$$m\ddot{x} + \frac{\partial V}{\partial x} + \frac{\partial E}{\partial x} = f$$

$$\frac{d}{dt}C(x)e = i$$

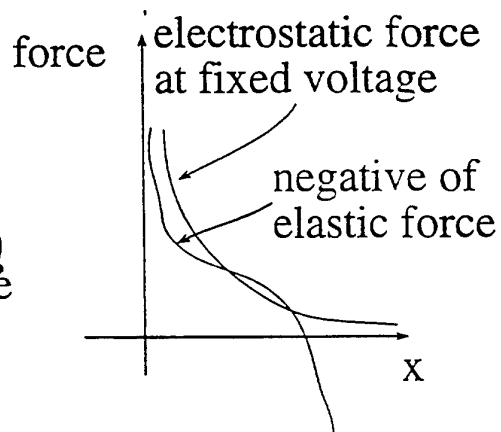
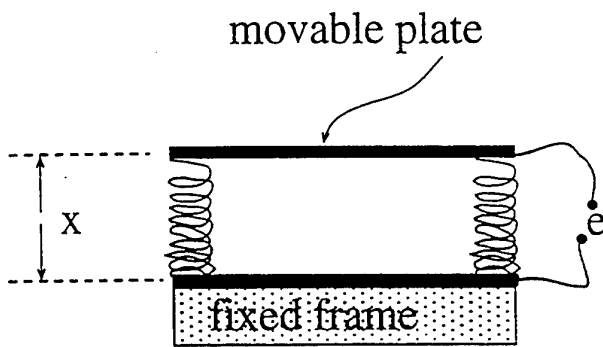
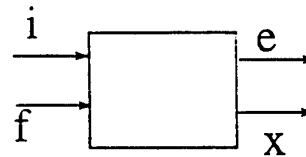

Highly nonlinear—equilibrium comes from electrostatic-elastic balance.

Electrical termination helps determine mechanical compliance.

The Small Strain Problem

For common piezoelectric materials the strain is small, $\Delta l/l \approx 10^{-4}$

The effect can be amplified with bilayers

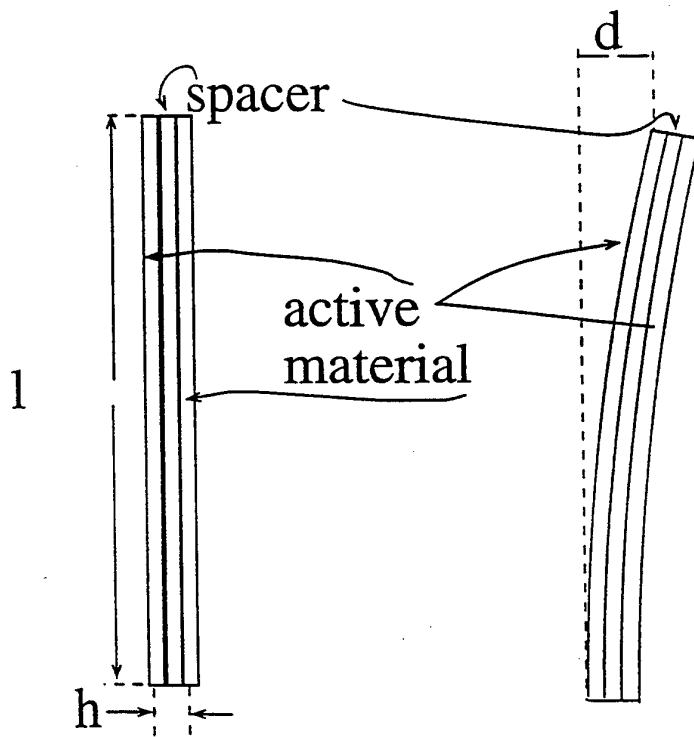

Assume that the layer on the left expands while the layer on the right contracts in equal amount. Then the curvature and displacement are

$$\text{curvature} = \frac{2\Delta l}{l \cdot h} \quad \text{displacement} = \frac{l\Delta l}{h}$$

Piezoelectric Motor (solid state 'motors')

Japan, early 90's, late 80's

A correctly phased set of sinusoidal voltage applied to a set of benders produces a change in the geometry of a solid in the form of a traveling wave.

exaggerated view of surface shape

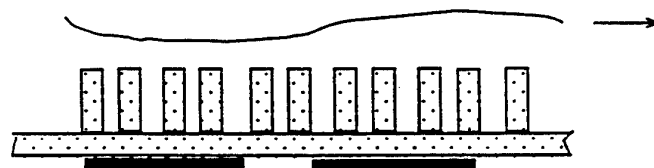

piezoelectric elements

The traveling wave can be coupled to a moving element to produce linear motion.

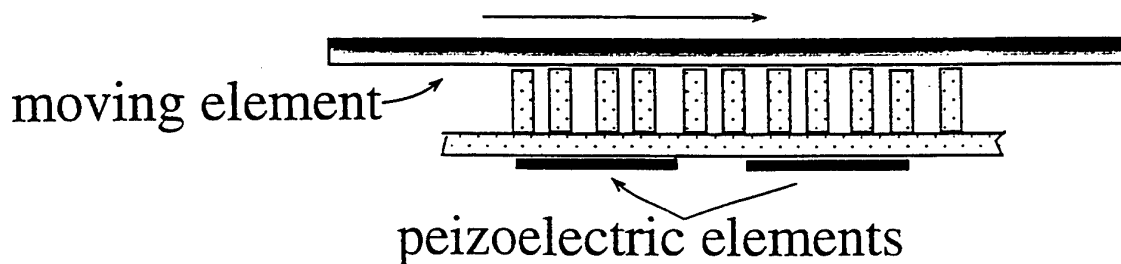

This is the basis for "ultrasonic" motors.

Piezoelectric effects (very high frequencies) (= solid state motors)

An applied voltage produces a change in the geometry of a solid. If the solid is a polarized sample of a material such as barium titanate the change is significant.

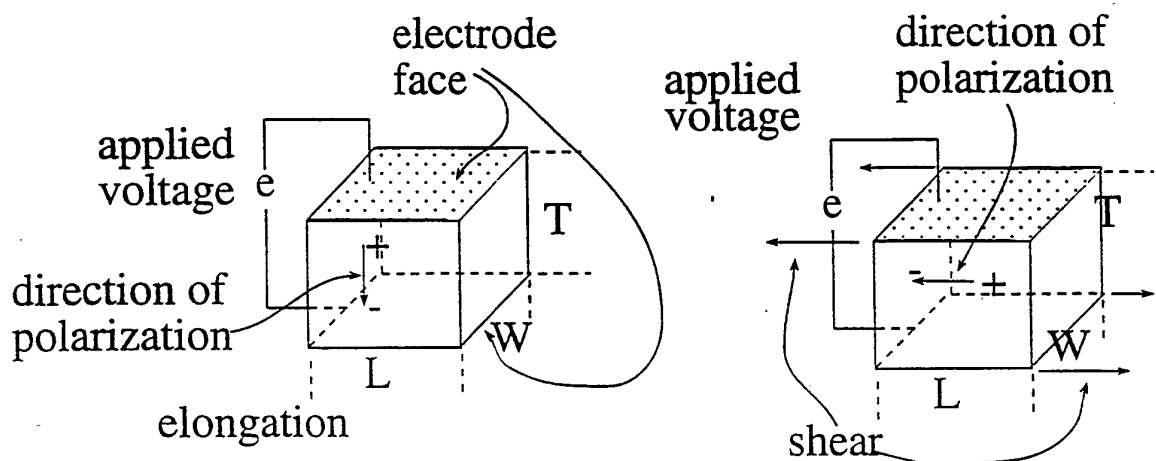

$$\begin{bmatrix} \frac{\delta L}{L} \\ \frac{\delta W}{W} \\ \frac{\delta T}{T} \end{bmatrix} = \begin{bmatrix} d_{31} \\ d_{31} \\ -d_{33} \end{bmatrix} \frac{e}{T} \text{ and } \theta = d_{15} \frac{e}{T}$$

d_{13} d_{33} and d_{15} are material properties.

θ is the shear angle in radians

Poling Piezoelectrics

Many piezoelectric materials acquire their special properties from the presence of internal electric dipoles whose existence is characteristic of ferroelectric materials.

Ferroelectric materials, like ferromagnetic materials, are most useful when prepared so as to be in particular equilibrium states.

In the case of ferroelectrics the preparation process produces an internal polarization and is achieved by application of a strong electric field during manufacture.

The effect of an electric field applied subsequently will depend on the orientation of the applied field, relative to the orientation of the polarization.

Hysteresis and Multiple Equilibria

Hysteresis is essential to the operation of ferromagnetic, ceramic piezoelectrics and phase change materials.

Hysteresis is both a static and a dynamic phenomenon.

A simple dynamic model for hysteresis takes the form

$$\dot{H} = H^2 N(u) - 2HN(u)H + N(u)H^2$$

If H is n by n and symmetric and N is diagonal then the system can have as many as $n!$ equilibrium states. Typically the output variable would take the form

$$y(t) = \text{tr} (H(t)M)$$

with M constant.

$\dot{H} = [H, [H, N]]$ ← other way of writing # equation
 (modified to:
 $\dot{H} = [H, [H, \text{diag } H N]]$ → modified to have many more stable equilibrium points that are driven by N

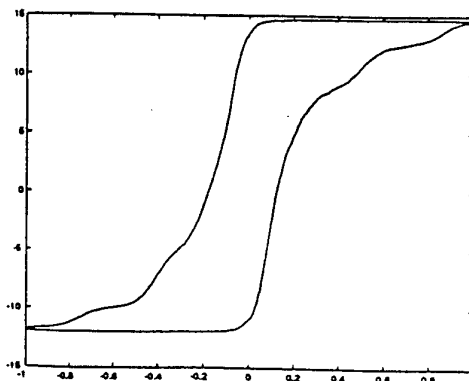

Actuation with Phase Change

Certain materials such as the nickel-titanium alloy Nitinol, change their internal structure at a critical temperature. This phase change is accompanied by a change in the geometry. If the sample is in the form of a wire there may be as much as a 10% change in its length. A prototype temperature-stress-length diagram and block diagram suggestive of the use of heat flow and stress as inputs, is shown.



Nitinol has been incorporated in a variety of devices in which the temperature change is produced by an electric current.

The Concept of Rectification

Small strain, high frequency oscillations must be “rectified” mechanically to generate rectilinear motion. What forms do mechanical rectifiers take?

$$\begin{array}{lll} \dot{x} = u & \text{becomes} & \dot{x} = \sin \omega t \\ \dot{y} = v & \text{becomes} & \dot{y} = \cos \omega t \\ \dot{z} = xv - yu & \text{becomes} & \dot{z} = 1 \end{array}$$

Inchworm kinematics involve clamping and deformation—a “discrete” version of these equations.

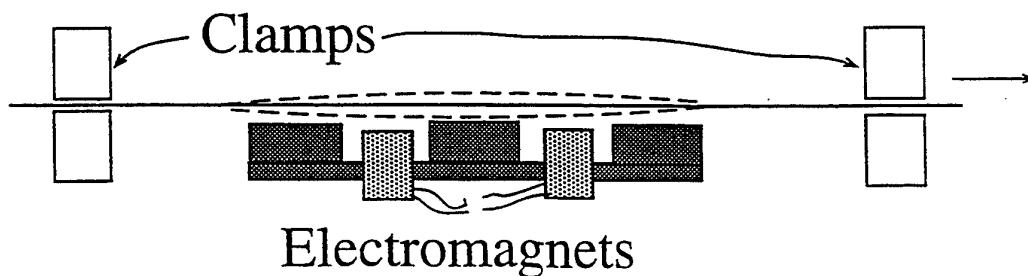

References

1. James R. Melcher, *Continuum Electromechanics*, MIT Press, Cambridge, MA. 1981.
2. *Piezo Systems Product Catalog*, Piezo Systems Inc. Cambridge, MA
3. *Encyclopedia of Physics*, (Rita Lerner and George Tigg, Eds.) VCH Publishers, New York, 1991.
4. Richard Feynman, et al. *Lectures on Physics*, Addison-Wesley, Reading MA, 1963.
5. R. W. Brockett, 'On the Rectification of Vibratory Motion,' *Sensors and Actuators*, Vol. 20 (1989) pp. 91-96.

Hierarchical Hybrid System Design for Unmanned Aerial Vehicles

S. S. Sastry

Intelligent Machines and Robotics Laboratory
Department of Electrical Engineering and Computer Sciences
University of California at Berkeley



Overview

- Motivation
- System Architecture
- Hybrid Systems
- Trajectory Generation & Flight Mode Selection
- Reactive System Synthesis
- Hybrid Simulation
- Numerical Method for Envelope Protection Controller Synthesis
- Future Research

Motivation

- Goal
 - Design a multi-vehicle multi-modal control system for Unmanned Aerial Vehicle (UAV)
 - › Intelligent coordination among agents
 - › Rapid adaptation to environments
 - › Interaction of models of operation
 - Guarantee
 - › Safety
 - › Performance
 - › Fault tolerance
 - › Mission completion

Conflict Resolution

Colli:

Enve

Tracking Error

Fl

Rt

Sensor Failure

Act: Path Following

Object Searching

Pursuit-Evasion



System Architecture

- Hierarchical Approach
 - ATMS
 - PATH - AHS
 - Communication Networks
- System Architecture
 - FMS
 - Strategic Planner
 - Tactical Planner
 - Trajectory Planner
 - Regulation
 - Detector
 - Dynamics

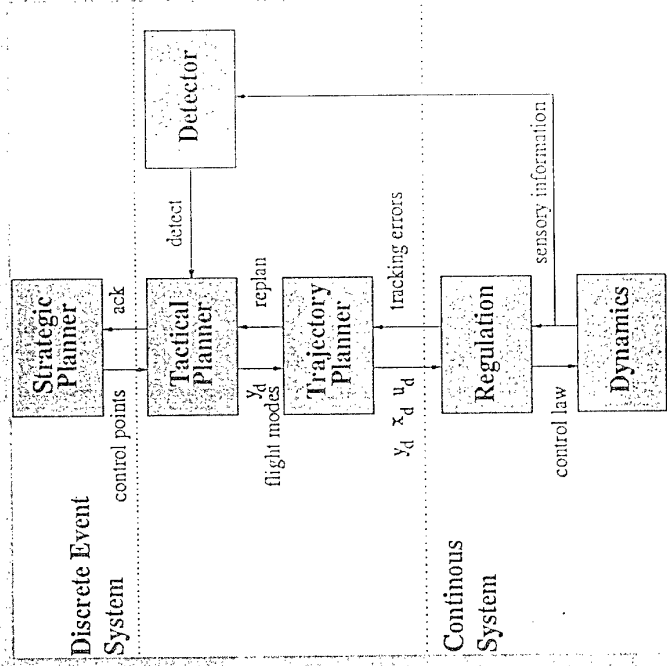

System Architecture

- FMS
 - Strategic Planner
 - Planning and execution of mission
 - Trajectory as a sequence of way-points
 - Communication among UAVs

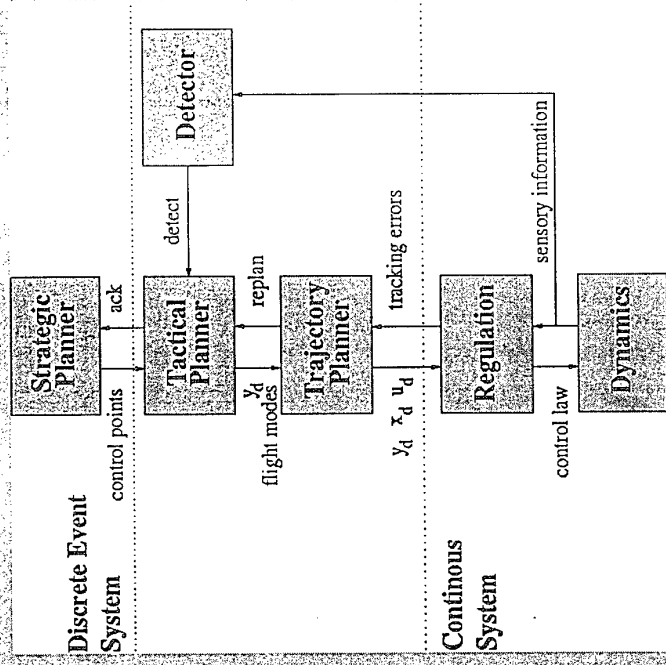

System Architecture

- FMS
 - Tactical Planner
 - Coordination among UAV/s
 - Conflict resolution
 - Fault handling
 - Output trajectory generation
 - Flight mode sequence generation
 - Utilizes abstracted (kinematic) model

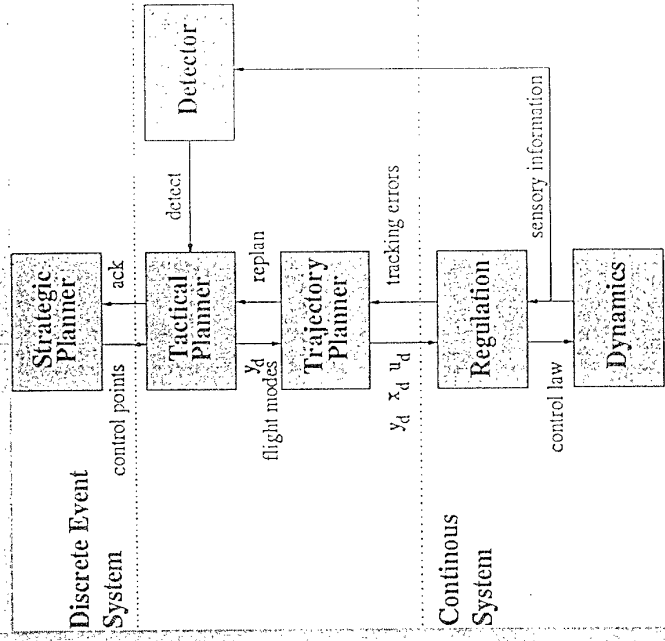

System Architecture

- FMS
 - Detector
 - Monitors changes in states and environments: chiefly fault modes, conflict potential, pop-up obstacles
 - Limited sensing capability
 - Communication with Tactical Planner

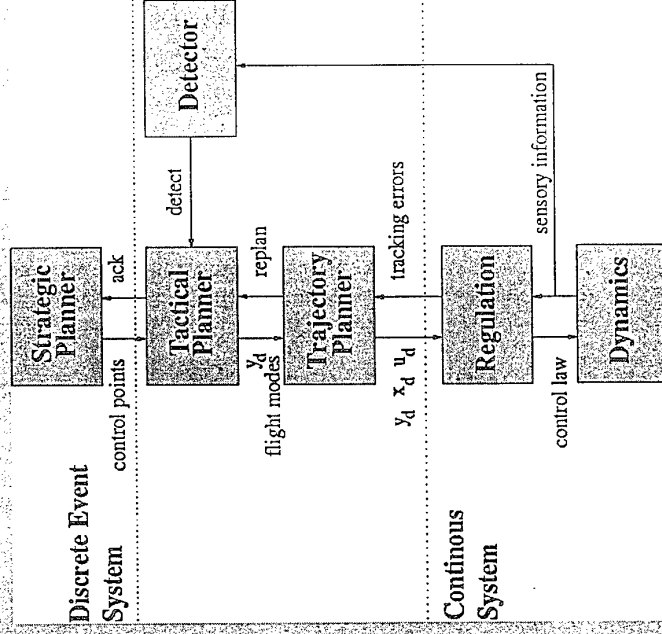

System Architecture

- FMS
 - Trajectory Planner
 - State and input trajectory generation based on the given output trajectory and flight mode
 - Utilizes dynamical model
 - Flight Envelope protection

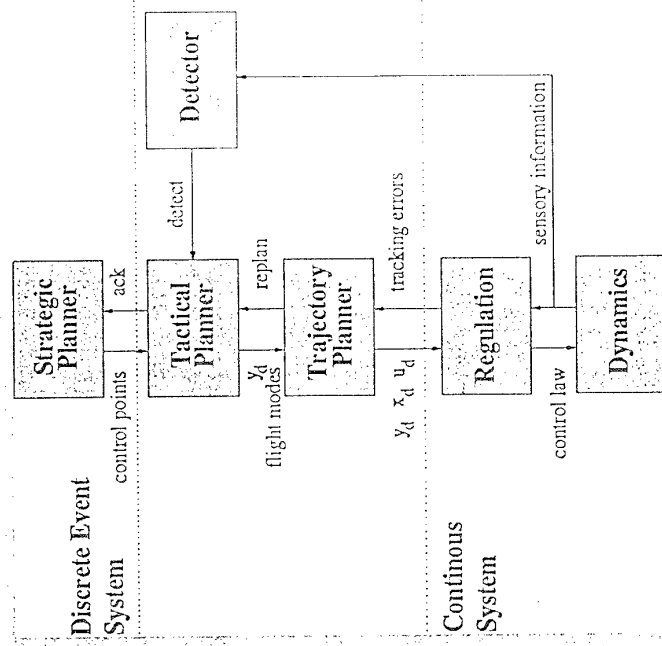

System Architecture

- FMS
 - Regulation
 - Containing sets of flight mode controllers
 - Controller switching based on the flight mode sequence
 - Utilizing state and input trajectory
 - Tracking error calculation

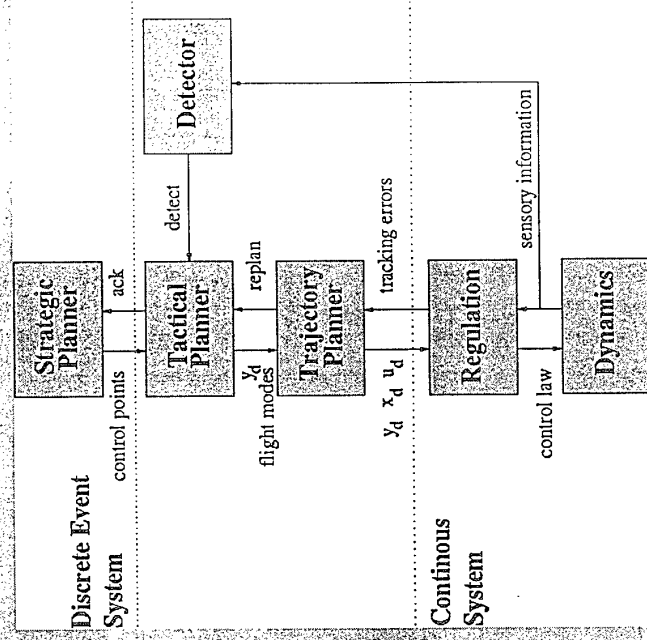

System Architecture

— Dynamics

$$\begin{bmatrix} \dot{P} \\ \dot{V} \\ \dot{R} \\ \dot{\omega} \end{bmatrix} = \begin{bmatrix} V \\ m^{-1} R f^b(u) + e_{3g} \\ I^{-1} (\tau^b(u) - \omega \times I \omega) \end{bmatrix}$$

$$x = \begin{bmatrix} P \\ V \\ R \\ \omega \end{bmatrix} \in \mathcal{R}^3 \times \mathcal{R}^3 \times SO(3) \times \mathcal{R}^3$$

$$u = \begin{bmatrix} T_M \\ T_T \\ a \\ b \end{bmatrix} \in \mathcal{R}^4 \quad u = \begin{bmatrix} T \\ \delta a \\ \delta e \\ \delta r \end{bmatrix} \in \mathcal{R}^4$$

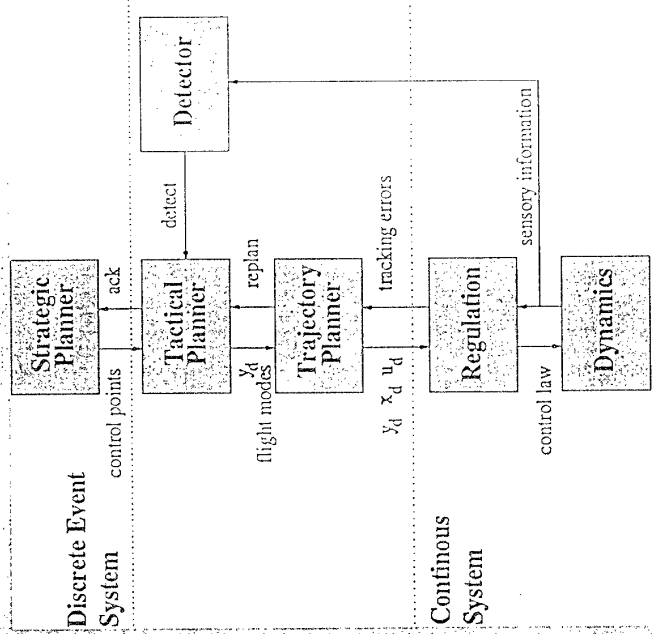

System Architecture

- Flight Mode Based Control System Design
 - Flight Mode
 - represents different control mode of the aerial vehicle and each corresponds to controlling different output variables in the dynamics.
 - Helicopter and Aircraft have four inputs
 - A flight mode is constructed by defining four outputs to form a square system from the output set
 - Total 15 combinations

$$y = [p_x \ p_y \ p_z \ \phi \ \theta \ \psi]^T$$

Hybrid System

- Research Issues
 - Continuous and discrete state spaces

Hybrid System

- Multiple, interacting modes of operation

Safety and Liveness



Hierarchical Hybrid System

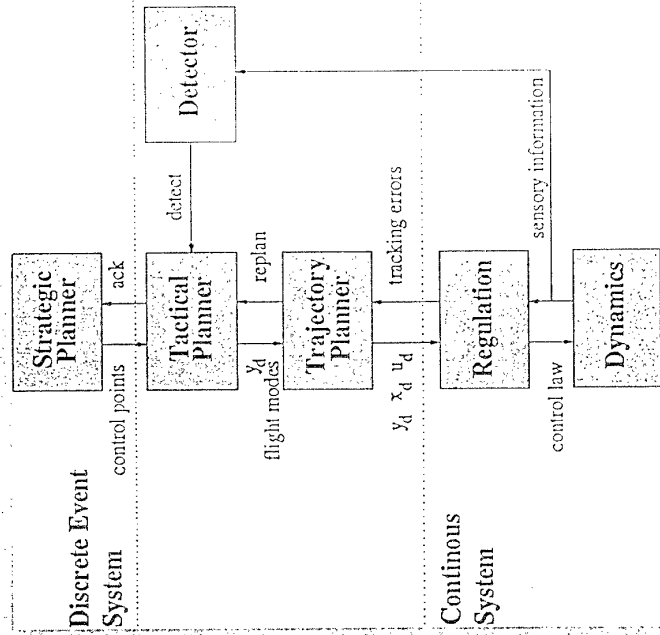

Hybrid System

- Two Major Research Directions
 - Numerical Method for Envelope Protecting Controller Synthesis
 - Flight Mode Hybrid Automaton Synthesis

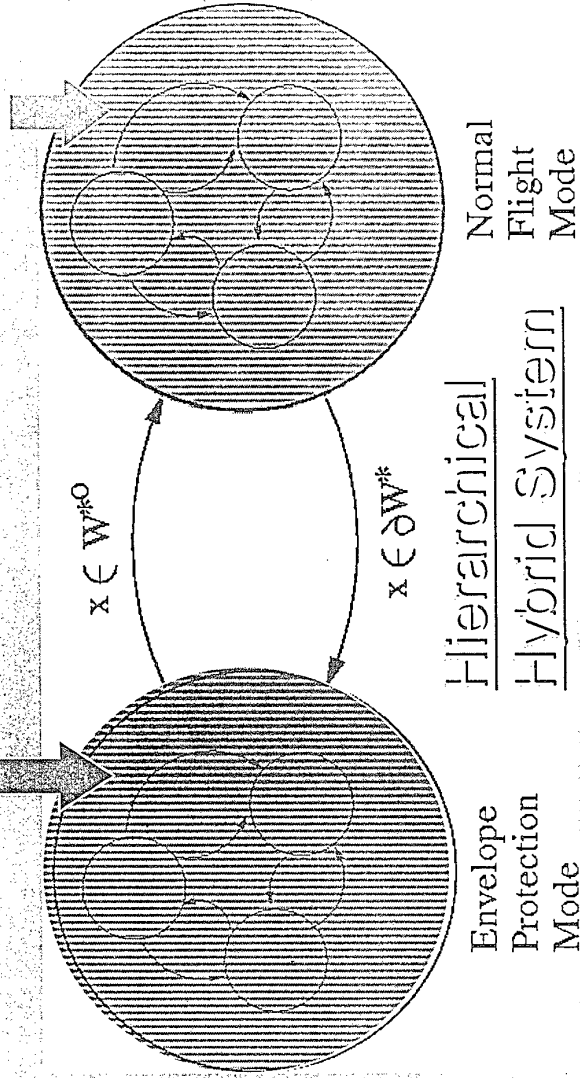

Hybrid System

Hybrid Automata (Lygeros and Sastry, 1999)*

$H = (Q, X, V, Y, \text{Init}, f, h, \text{Inv}, E, G, R, \phi)$

- Q is a finite collection of discrete state variables;
- X is a finite collection of continuous state variables;
- V is a finite collection of input variables, $V = V_D \cap V_C$;
- Y is a finite collection of output variables, $Y = Y_D \cap Y_C$;
- $\text{Init} \subseteq Q \times X$ is a set of initial states;
- $f: Q \times X \times V \rightarrow \mathbb{R}^n$ is a vector field;
- $h: Q \times X \rightarrow Y$ is an output map;
- $\text{Inv}: Q \rightarrow 2^{X \times V}$ assigns to each $q \in Q$ an invariant set;
- $E \subset Q \times Q$ is a collection of discrete transition;
- $G: E \rightarrow 2^{X \times V}$ assigns to each $e \in E$ a guard;
- $R: E \times X \times V \rightarrow 2^X$ defines a reset relation; and,
- $\phi: Q \times X \rightarrow 2^V$ defines a set of admissible inputs.

Hybrid System

Assumption: Assume $f(q, x, v)$ and $h(q, x)$ are globally Lipschitz continuous in x and $f(q, x, v)$ is continuous in v .

Definition: An execution χ of a hybrid automaton $H \in \mathcal{H}$ is a collection $\chi = (\tau, q, x, v, y)$ with $\tau \in \mathcal{T} = \{[\tau_i, \tau'_i]\}_{i=1}^{\mathcal{N}}$, $q: \tau \rightarrow Q, x: \tau \rightarrow X, v: \tau \rightarrow V$, and $y: \tau \rightarrow Y$ satisfying:

- **Initial Condition:** $(q(\tau_0), x(\tau_0)) \in \text{Init}$;
- **Continuous Evolution:** for all i with $\tau_i < \tau'_i$, q, x, v, y are continuous over $[\tau_i, \tau'_i]$ and $\forall t \in [\tau_i, \tau'_i], (x(t), v(t)) \in \text{Inv}(q(t))$ and $\dot{x} = f(q(t), x(t), v(t))$;
- **Discrete Evolution:** $\forall i, 1) (q(\tau'_i), x(\tau'_i)) = (q(\tau_{i+1}), x(\tau_{i+1}))$
2) $e_i = (q(\tau'_i), q(\tau_{i+1})) \in E, (x(\tau'_i), v(\tau'_i)) \in G(e_i)$,
and $x(\tau_{i+1}) \in R(e_i, x(\tau'_i), v(\tau'_i))$;
- **Input Evolution:** $\forall t \in \tau, v(t) = \phi(q(t), x(t))$;
- **Output Evolution:** $\forall t \in \tau, y(t) = h(q(t), x(t))$.

Hybrid System

Enabled Discrete Evolution

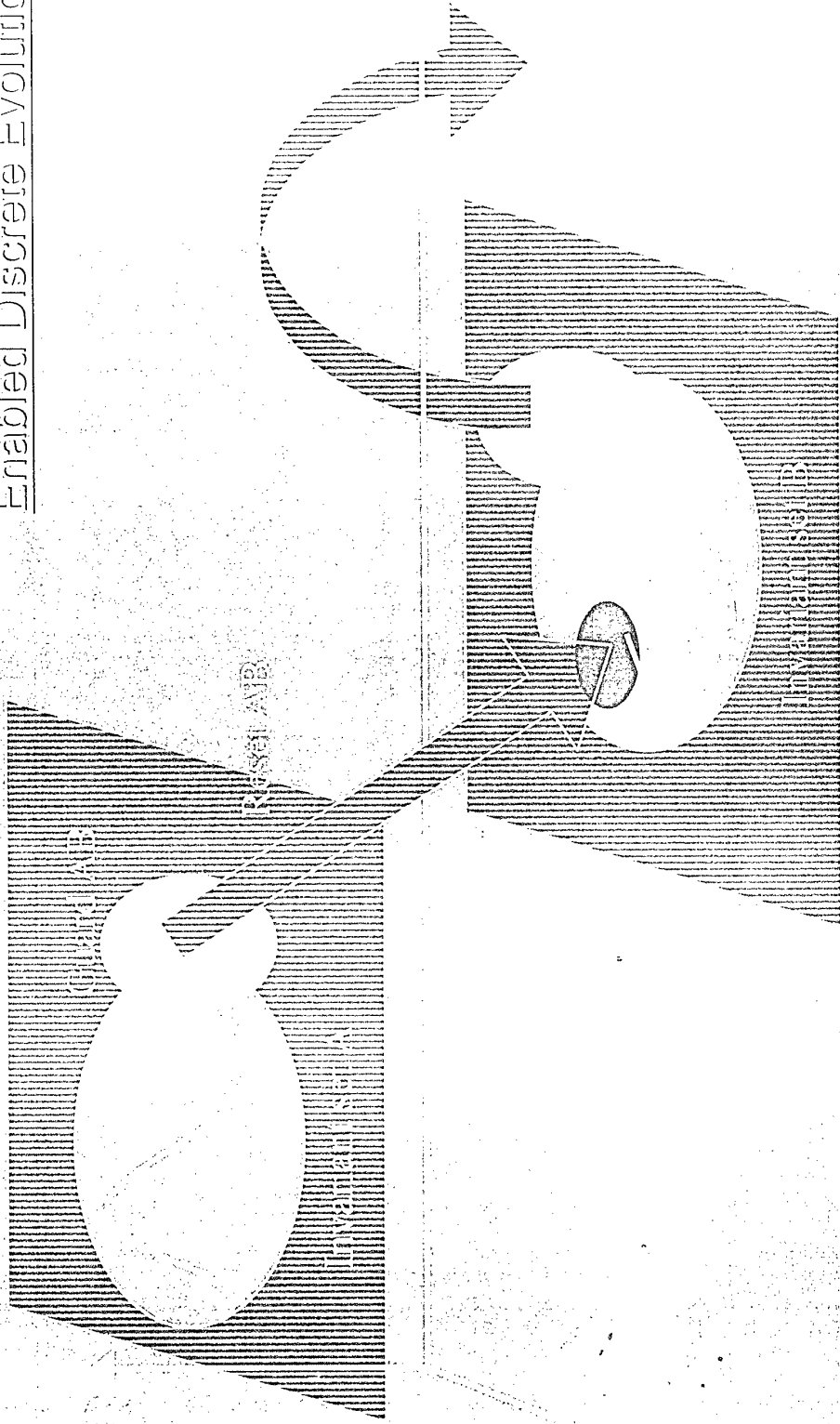

RUSSEL A/B

HYBRID SYSTEM

Hybrid System

Forced Discrete Evolution

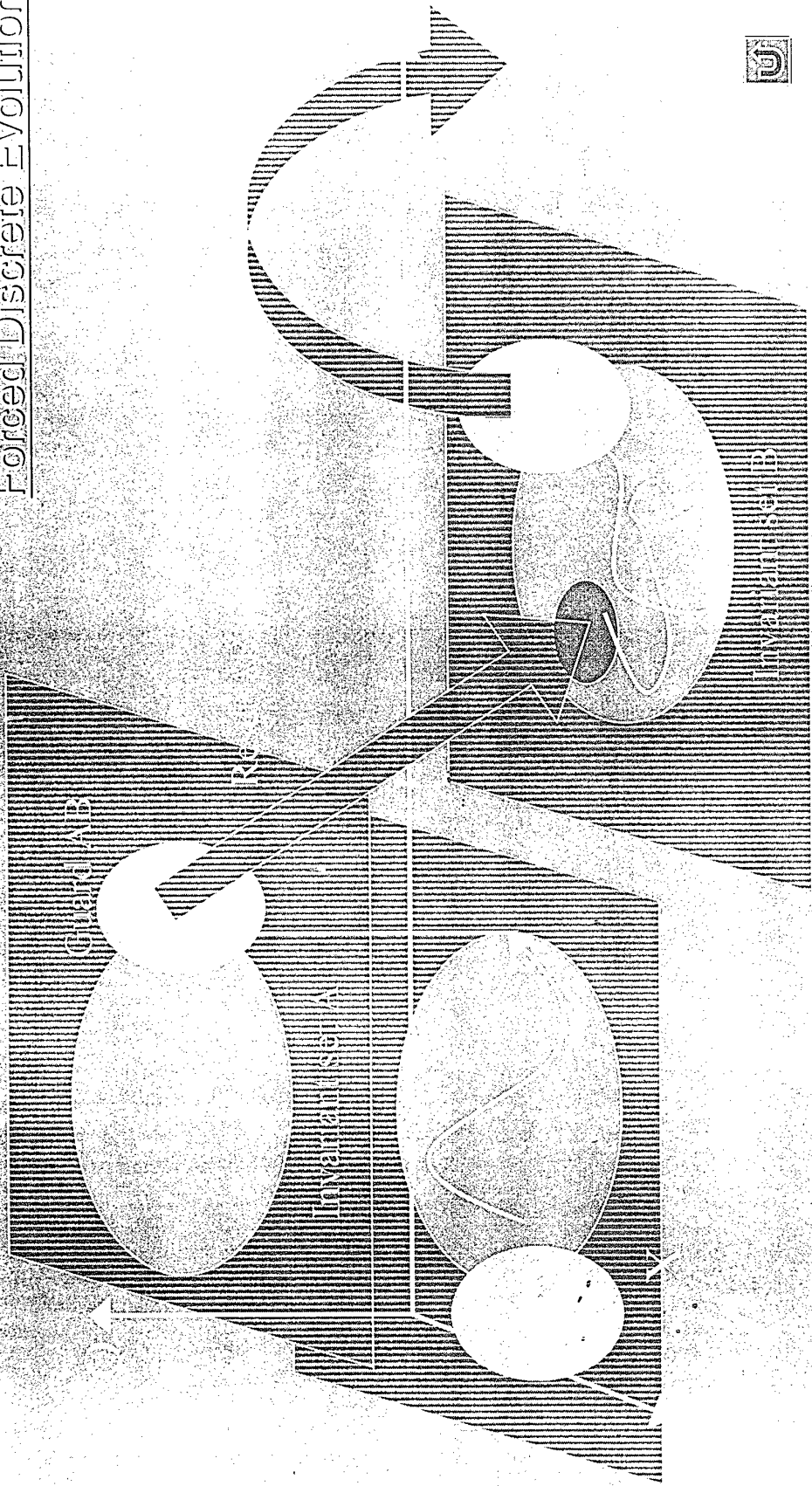

Trajectory Generation and Flight Mode Selection

- Output path planning and flight mode scheduling (*Egerstedt, Koo, Hoffmann & Sastry, HSCC, 1999*)
 - Generation flat output trajectories and flight mode sequence associated
 - Each closed loop flight mode dynamics modeled by linear system and boundary conditions
 - Mode switching occurs at specific time

$$\dot{x} = A_i x + b_i u, \quad x \in \mathcal{R}^n, \quad u \in \mathcal{R}, \quad i = 1, \dots, N$$

Trajectory Generation and Flight Mode Selection

- Output path planning and flight mode scheduling
 - Convex optimization problem
 - Computationally efficient optimal trajectory generation
 - Optimal flight mode sequence synthesis
 - Weighting matrix specifies how important to have the state being close to the desired one at a specific time

$$J(u) = \frac{1}{2} \rho \int_0^T u(s)^2 ds + \sum_{k=1}^m \frac{1}{2} (x(t_k) - \alpha_k)^T \tau_k (x(t_k) - \alpha_k)$$

Reactive System Synthesis

- System Specifications
 - Reactivity
 - Concurrency/Sequencing
 - Strict time and reliability
 - Deterministic
- POLIS
 - Design prototyping
- Ptolemy
 - Validation

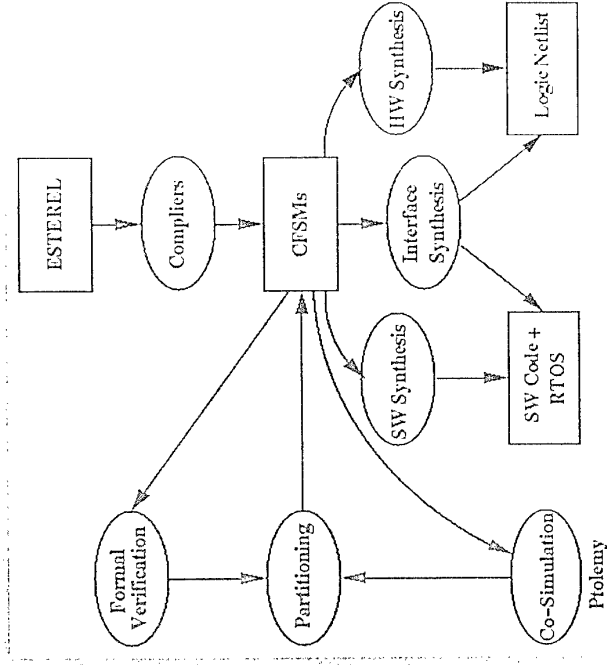

Reactive System Synthesis

- Reactive System Design
 - Esterel : Synchronous Language
 - Signal reading/writing
 - Basic control and looping
 - Sequencing
 - Concurrency
 - Preemption
 - Real-time system synthesis
 - HW//SW partition
 - Verification
 - Finite State Machine (FSM)

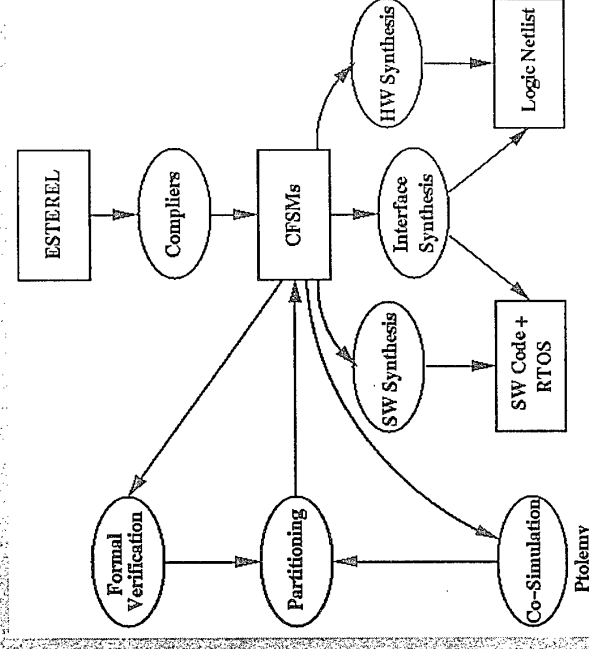

Reactive System Synthesis

- Reactive System Design
 - Tactical Planner
 - Operation mode switching
 - Flight mode switching
 - Trajectory Planner
 - Trajectory generation
 - Dynamics
 - Time Discretization of

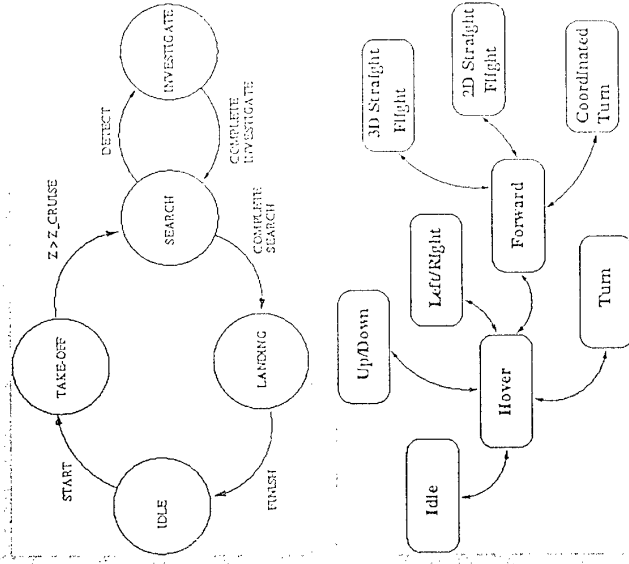

$$\ddot{x} = a_x, \quad \ddot{y} = a_y, \quad \ddot{z} = a_z, \quad \ddot{\psi} = a_\psi$$

Reactive System Synthesis

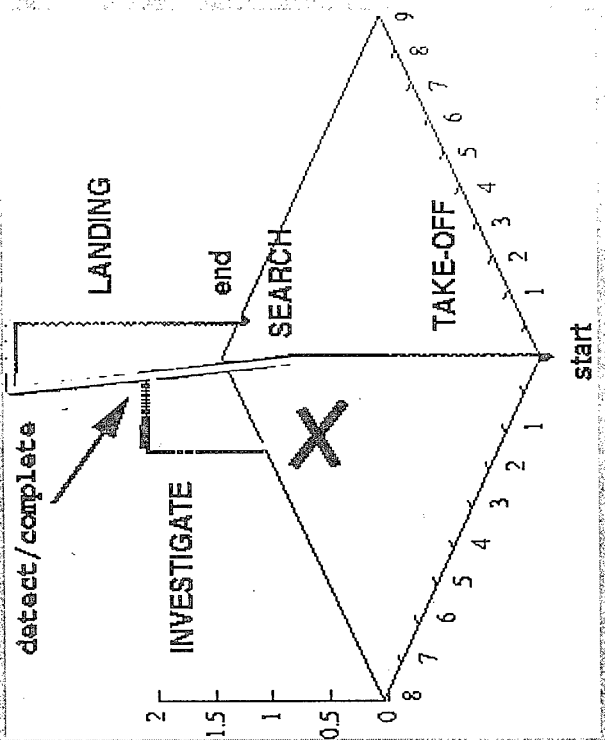
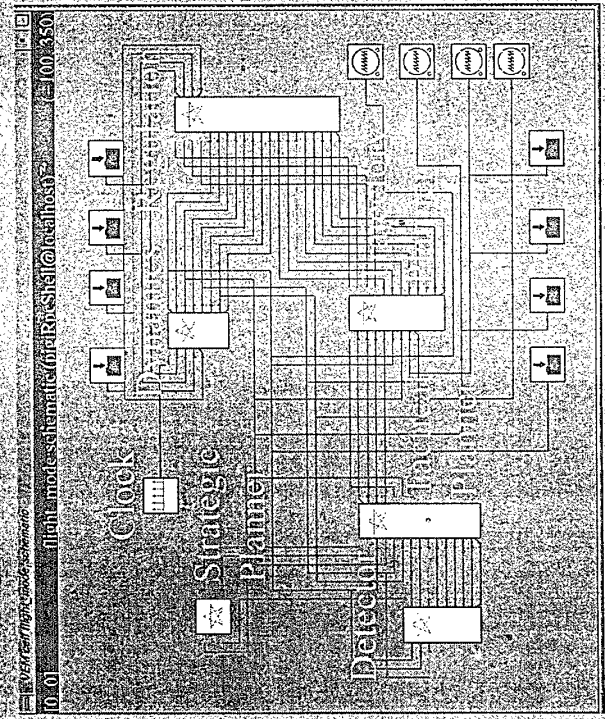
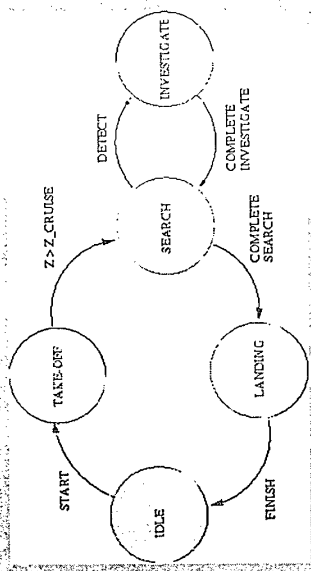

Hybrid Simulation

- Hierarchical Hybrid System Simulation (*Liu, Liu, Koo, Sinopoli, Sastry & Lee, CDC, 1999*)
 - SHIFT
 - Dynamic Networks of Hybrid Automata
 - Omola
 - Continuous Time and Discrete Event Dynamical Systems
 - Ptolemy II
 - Hierarchical Heterogeneous System with Multiple Model of Computations. (MOC)

Hybrid Simulation

- Hierarchical Hybrid System Simulation (*Liu, Liu, Koo, Sinopoli, Sastry & Lee, CDC, 1999*)
 - Modeling of Hybrid System
 - Finite State Machine
 - Continuous Time Dynamics
 - Mixed-Mode Simulation in PtolemyII
 - Event Detection/Generator
 - ODE Solver
 - Invariant Monitor

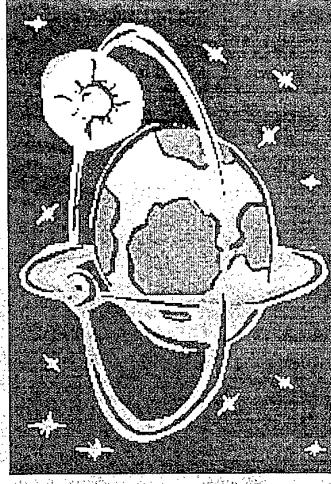

Hybrid Simulation

- Hierarchical Hybrid System Simulation (Liu, Liu, Koo, Sinopoli, Sastry & Lee, CDC, 1999)
 - Modeling of complex flight mode switching of helicopter in take-off phase
 - 2D helicopter model
 - Flight mode control design based on feedback linearization

$$\begin{bmatrix} \ddot{p}_x \\ \ddot{p}_z \end{bmatrix} = \frac{1}{m} R(\theta) \begin{bmatrix} R^T(\alpha) \begin{bmatrix} -D(V) \\ 0 \end{bmatrix} - \begin{bmatrix} T_M \sin \alpha \\ T_M \cos \alpha \end{bmatrix} \end{bmatrix} + \begin{bmatrix} 0 \\ g \end{bmatrix},$$
$$\ddot{\theta} = \frac{1}{I_y} (M_M a + h_M T_M \sin \alpha), \quad \alpha = \theta - \tan^{-1} \left(\frac{\dot{p}_z}{\dot{p}_x} \right)$$

Hybrid Simulation

- o Hierarchical Hybrid System Simulation (Liu, Liu, Koo, Sinopoli, Sastry & Lee, CDC, 1999)
 - Modeling of complex flight mode switching of helicopter in take-off phase
 - o Flight mode automaton

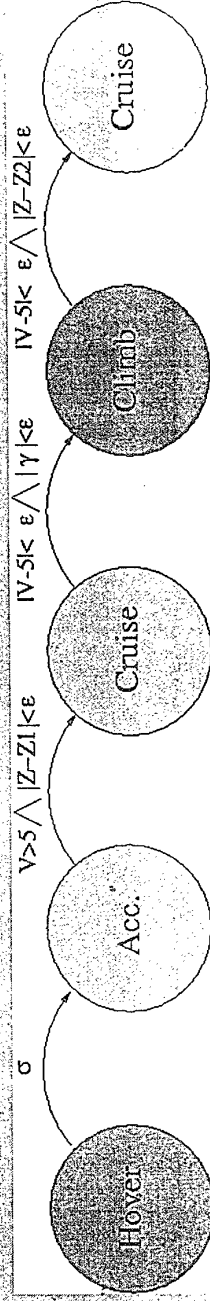

Hybrid Simulation



Applet

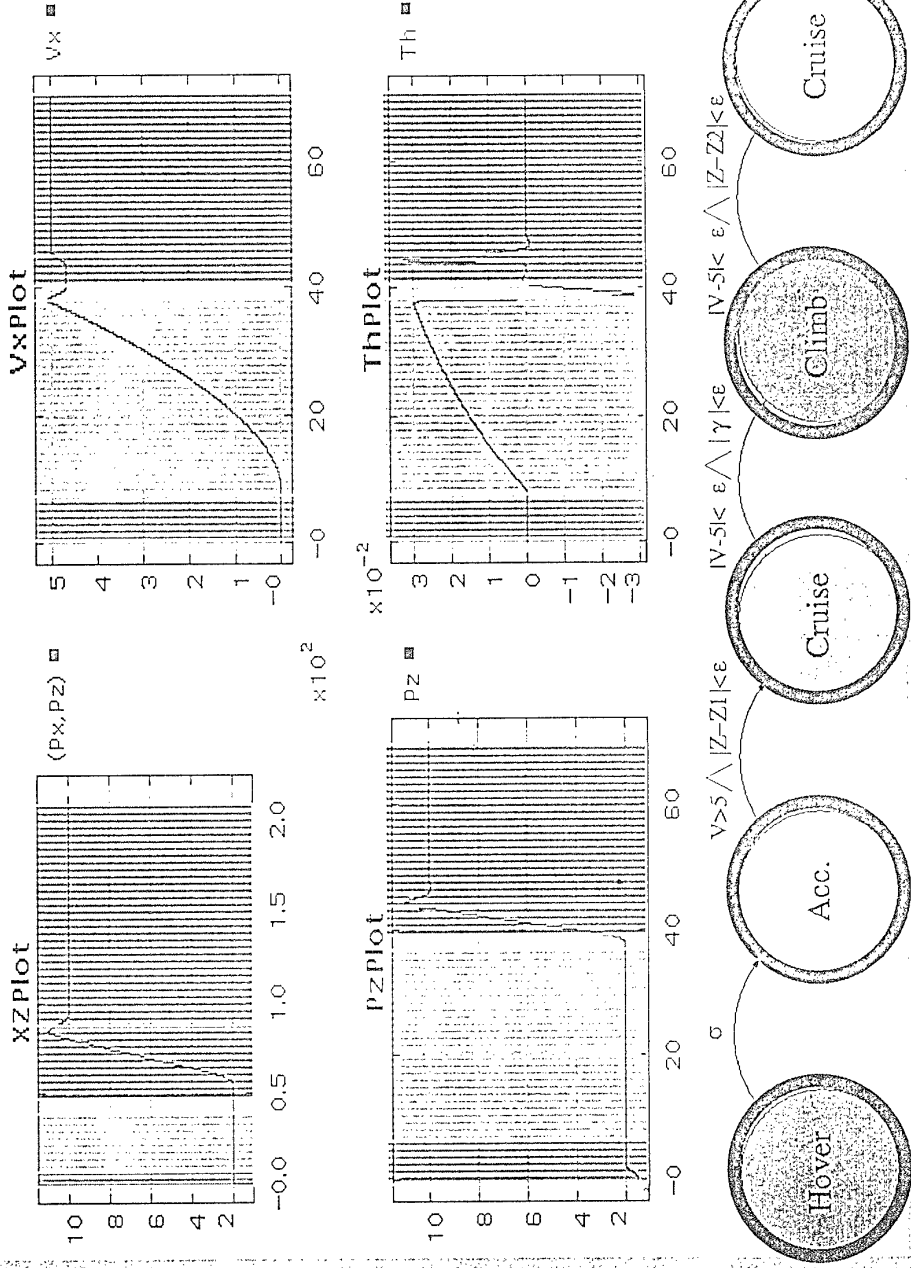

Numerical Method for Envelope Protecting Controller Synthesis

- Envelope Protecting Controller Synthesis
 - 2-D Longitudinal Aircraft Dynamics (Lygeros et. al., 1999)*

$$\dot{V} = \frac{T - D(V, \gamma, \theta)}{m} - g \sin \gamma, \quad \dot{\gamma} = \frac{L(V, \gamma, \theta)}{mV} - \frac{g \cos \gamma}{V}$$

- 2 States and 2 Inputs $x = [V \ \gamma]^T, \quad u = [T \ \theta]^T$
- Flight Envelope $l^i(x) = 0$ for $i = 1, \dots, 4$
- Safe Set $F = \{x \in X \mid \forall i \in \{1, 2, 3, 4\}, l^i(x) \geq 0\}$

Numerical Method for Envelope Protecting Controller Synthesis

- Envelope Protecting Controller Synthesis
 - Determine the largest controlled invariant safe set
 - Classify the least restrictive safe controls

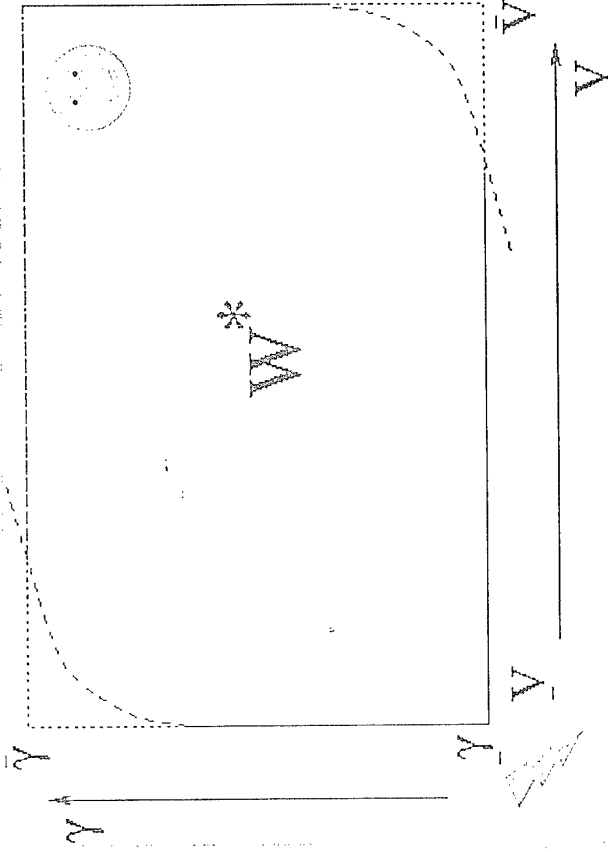

Numerical Method for Envelope Protecting Controller Synthesis

Envelope Protecting Controller Synthesis

- Value Function $J^i(x, u(\cdot), t) = l^i(x(0))$
- Optimal Cost $J^{i*}(x, t) = \max_{u(\cdot) \in U} J^i(x, u(\cdot), t)$
- Optimal Hamiltonian
- Hamilton-Jacobi equation $H^{i*}(x, p) = \max_{u \in U} p^T f(x, u)$

$$\begin{aligned} - \quad & \frac{\partial J^{i*}(x, t)}{\partial t} = \min \left\{ 0, \max_{u(\cdot) \in U} \frac{\partial J^{i*}(x, t)}{\partial x} f(x, u) \right\} \\ & J^{i*}(x, 0) = l^i(x) \end{aligned}$$

Solved by analytical method and simulation (Lygeros et. al., 1999)*

Numerical Method for Envelope Protecting Controller Synthesis

- Proposed Numerical Method
 - Based on Finite Element Method
 - Value function defined at each node and interpolated in each element
 - Game between approximation error and control
 - Optimal cost
 - Hamilton-Jacobi equation
$$J^{i*}(x, t) = \max_{u(\cdot) \in U} \min_{d(\cdot) \in D} [\hat{J}^i(x, u(\cdot), t) + d(\cdot)]$$

$$\begin{aligned} - \quad \frac{\partial \hat{J}^{i*}(x, t)}{\partial t} &= \min\{0, \max_{u \in U} \min_{d \in D} \left\{ \frac{\partial \hat{J}^{i*}(x, t)}{\partial x} f(x, u) + \delta(d) \right\}\} \\ J^{i*}(x, 0) &= l^i(x) \end{aligned}$$

Numerical Method for Envelope Protecting Controller Synthesis

- Proposed Numerical Method
 - Result will be compared with the analytical one for validation

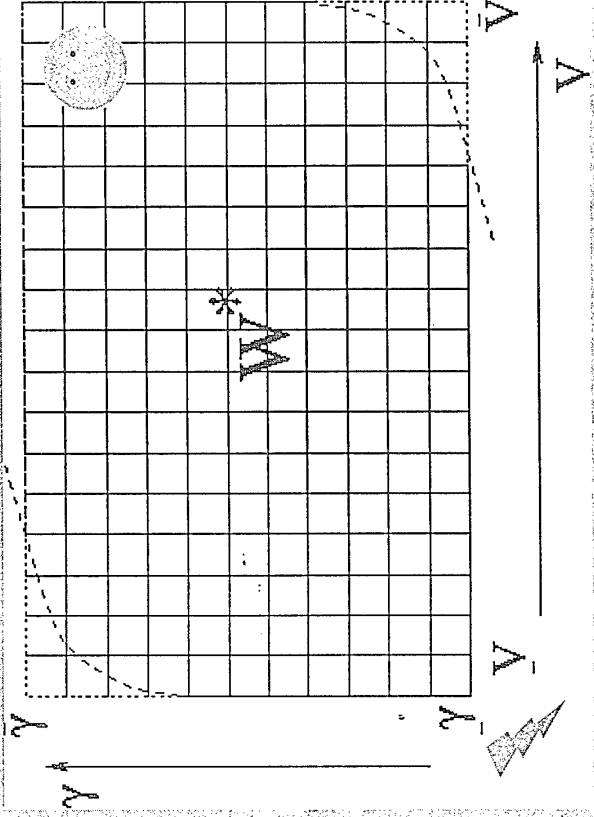

Numerical Method for Envelope Protecting Controller Synthesis

- o Extension to Helicopter Application
 - *Dead Man's Curve*, the Height-Velocity diagram

If the engine fails while the helicopter is in the safe area, there exists an autorotation procedure to land safely.

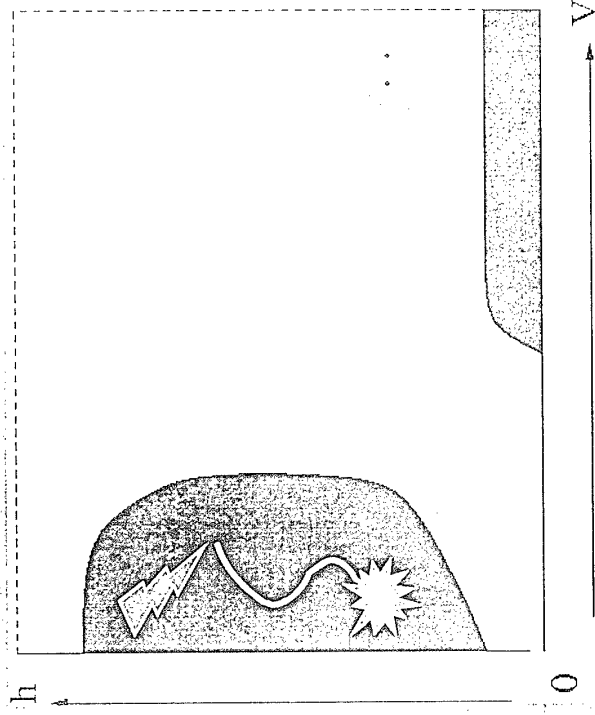

Numerical Method for Envelope Protecting Controller Synthesis

- Extension to Helicopter Application
 - Extension to 2D Longitudinal Helicopter Dynamics

$$\begin{bmatrix} \dot{p}_x \\ \dot{p}_z \end{bmatrix} = \frac{1}{m} R(\theta) \begin{bmatrix} -D(V) \\ 0 \end{bmatrix} - \begin{bmatrix} T_M \sin a \\ T_M \cos a \end{bmatrix} + \begin{bmatrix} 0 \\ g \end{bmatrix},$$
$$\ddot{\theta} = \frac{1}{I_y} (M_M a + h_M T_M \sin a), \quad \alpha = \theta - \tan^{-1} \left(\frac{\dot{p}_z}{\dot{p}_x} \right)$$

- Based on *Dead Man's Curve*, the Height-Velocity diagram, there are 3 States and 2 Inputs

$$x = [\dot{p}_x \ p_z \ \dot{p}_z]^T, \quad u = [T_M \ \theta]^T$$

- Apply the same Numerical Method to solve the problem

Future Research

- Flight Mode Hybrid Automaton Synthesis
 - Objective
 - Develop an algorithm to construct a flight mode hybrid automaton to satisfy the given specification
 - Problem
 - Liveness \Leftarrow Reachability
 - Example

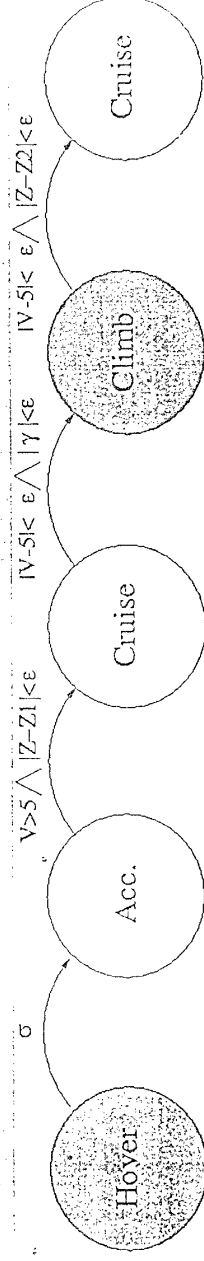

UAV Flight Control System Design

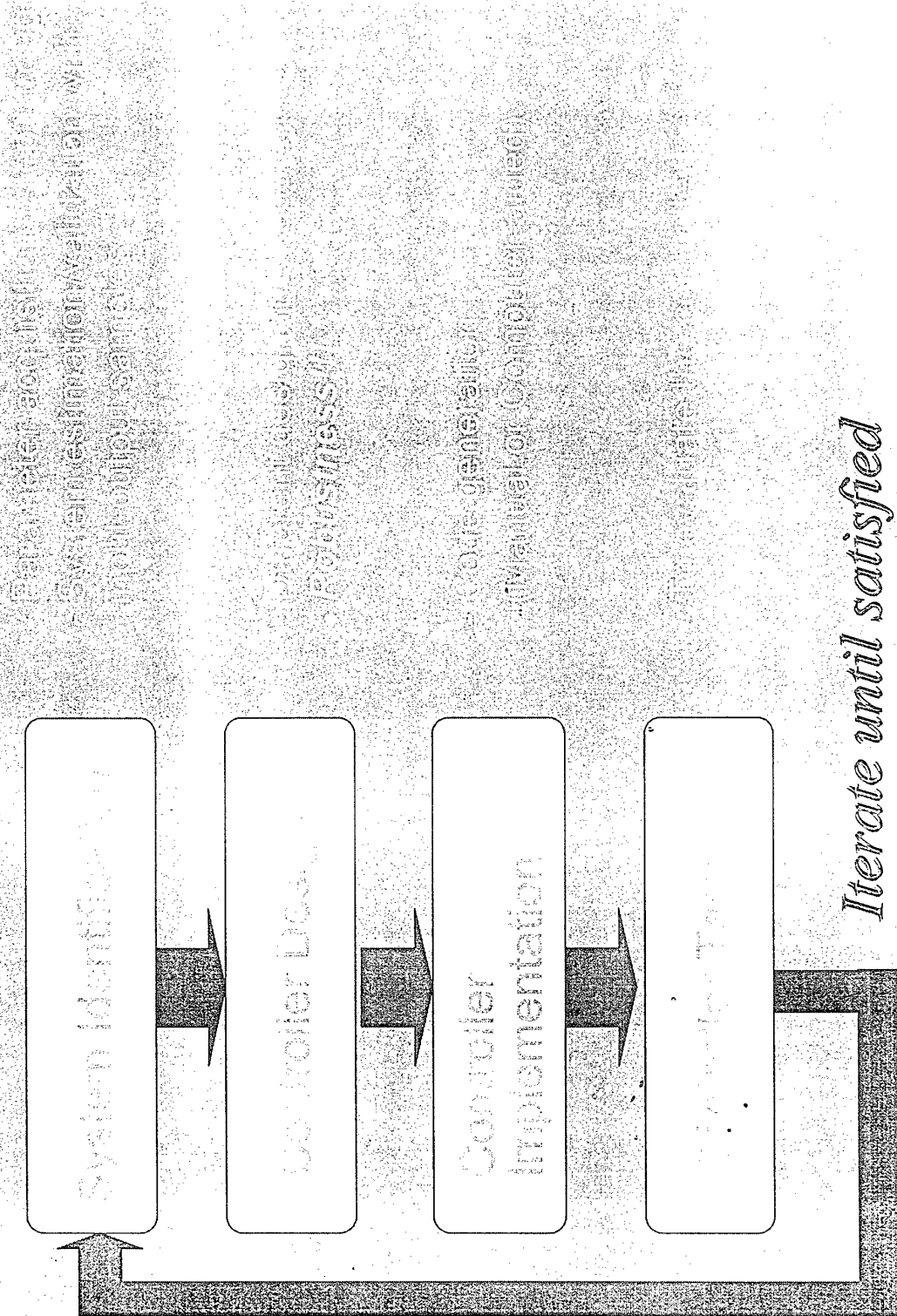

Existing Tools

System Modeling & Identification

- Spreadsheet-based linear state equation generator
(and much more)
- C-based linear state equation generator
ancestor to the spread-sheet version
- Parameterized Nonlinear helicopter model analysis
tool using *Mathematica*...
- Matlab CMEX code for Simulink

Existing Tools- Visualization

Off-line 3D visualization

- Useful tool to visualize the 3D motion of multiple number of UAV's
- Uses OpenGL extension in Windows 98/NT
- DDE (Dynamic Data Exchange) enhanced version available--trajectory generated by Matlab or any other software supporting DDE is directly connected

Towards an Integrated Development Environment

Current situation: Isolated tools

- Tools are realized using different application software and different OS.
- Information has to be manually processed.
- As the steps are iterated, human errors are likely to be introduced.

Towards An Integrated Development Environment

Tool Integration

- Provide the "link" among the software tools DDE
- Design convenient, intuitive user interfaces for *rapid prototyping*
- semi-automatic tools are available
- Realtime workshop, D-space, Matrix-X

Integrated Development Environment

Environment

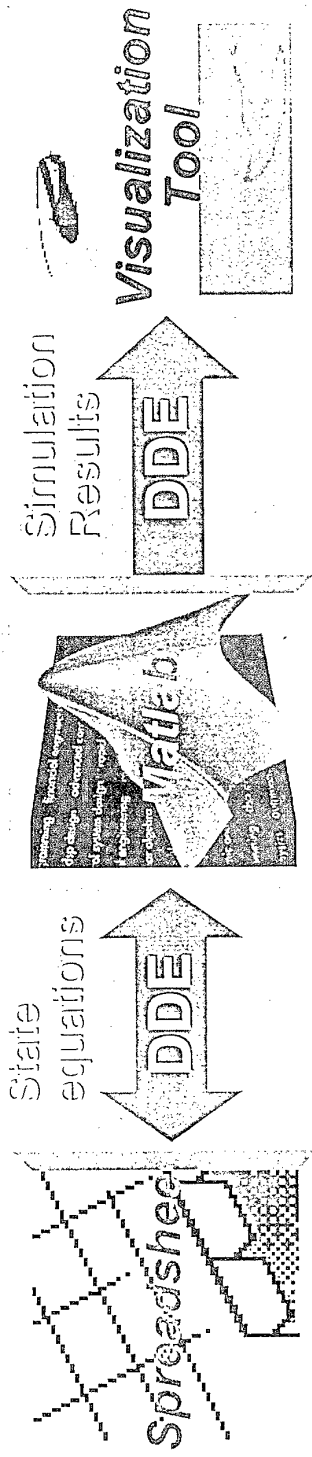

Designed Controller

Simulation Results

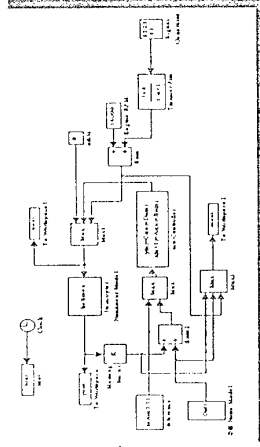

Nonlinear Simulation
in Simulink

Faculdade de Engenharia
da Universidade do Porto
Departamento de Engenharia Química
Instituto de Sistemas e Robótica



**Issues on computer-aided process operation:
Hybrid networks for
Process Modelling and Control**

Sebastião Feyo de Azevedo and Rui Oliveira

E-mail: sfeyo@fe.up.pt

WWW: <http://www.fe.up.pt/~sfeyo/>

Workshop on
Future Directions in Systems and Control Theory

22-25 June, 1999

Hotel Baía, Cascais, Portugal

**Issues on Computer-aided Process Operation:
Hybrid Networks for Process Modelling and Control**

Sebastião Feyo de Azevedo and Rui Oliveira

Department of Chemical Engineering / Institute for Systems and Robotics, Faculty of Engineering, University of Porto, Rua dos Bragas, 4099 Porto Codex, Portugal, E-mail: sfeyo@fe.up.pt

Issues concerning the theory and practice of computer-aided process operation (CAPO) will be addressed in this lecture. In essence, the topics to be discussed relate to new emerging knowledge engineering techniques and to how they can be used and integrated in the so-called 'process industries' for improving their performance.

The development of new or improved forms of process operation, be it a chemical or a biochemical process, is only successfully achieved when it is possible to match the theoretical innovation with the technology available for implementation at industrial scale. A kind of landmark in the history of CAPO can be recognised as having been reached at the close of the eighties. Nowadays, a large number of control systems suppliers offer the capabilities of the digital technology, employing open architecture and standard operating systems and, particularly, allowing external and independent modules to be incorporated into the control configurations. The flexibility and computational power are now available, with industrial standards, to implement monitoring and identification strategies, to develop software sensors, to implement, at local level, new and more efficient digital controllers and, at supervisory level, knowledge-based applications. Artificial Neural Networks and Fuzzy Inferential Systems are today tools which can be incorporated into the available industrial equipment without hard computational power constraints.

The phenomenological knowledge available is usually scarce and its use for implementing supervisory strategies is generally difficult and too expensive. For this reason many decisions concerning process operation keep being made today on the basis of the heuristic knowledge of plant engineers and operators. Knowledge engineering techniques open the possibility for incorporating qualitative information and information hidden in process data records into the supervisory system, thus increasing greatly the spectrum of knowledge available for improving process performance.

This lecture will focus on a new technique: Knowledge-Based Hybrid Networks for process monitoring, control and optimisation. Such Networks are computational structures which combine available classical mathematical models with knowledge-based numeric computation techniques. The advantage of such a methodology in comparison to the classic phenomenological model-based approach alone is that more knowledge can be used: i) the heuristic knowledge of process engineers and operators - using Fuzzy Inference Systems - and ii) the knowledge hidden in process data records - using Neural computational methods.

The concepts will be illustrated with the application to the operation of fermentation processes.

References

Bastin, G and D. Dochain, *On-line Estimation and Adaptive Control of Reactors*, Elsevier, Amsterdam, 1990

Schubert, J., R. Simutis, M. Dors, I. Havlik and A. Lübbert, *Bioprocess Optimisation and Control: Application of Hybrid Modelling*, *J. of Biotechnology*, 35, 51-68, 1994

Montague, G. and J. Morris, *Neural-network contributions in biotechnology*, *Tibtech*, 12 312-323, (August) 1994.

Menezes, J.C., S. Alves, J. Lemos and S. Fayo de Azevedo, *Mathematical Modelling of Industrial Pilot-Plant Penicillin-G Fed-Batch Fermentations*, *J. Chem Tech. Biotechnology*, 61 123-138, 1994.

Menezes, J.C., *Analysis and Modelling of Penicillin-G production at pilot scale*, Ph.D. Thesis, Universidade Técnica de Lisboa, 1996 (in Portuguese).

Oliveira, R., E. Ferreira, F. Oliveira and S. Fayo de Azevedo, *A Study on the Convergence of Observer-Based Kinetics Estimators in Stirred Tank Bioreactors*, *Journal of Process Control*, 6 (6) 367-371, 1996.

Simutis, R. Oliveira, M. Manikowski, S. Fayo de Azevedo and A. Lübbert, *How to Increase the Performance of Models for Process Optimization and Control*, *J. Biotechnology*, 59, 73-89, 1997

Fayo de Azevedo, S., B. Dham and F. Oliveira, *Hybrid Modelling of Biochemical Processes: a comparison with the conventional approach*, *Computers Chem. Engng*, 21 Suppl., S751-S756, 1997

Oliveira, R., *Supervision, Control and Optimisation of Biotechnological Processes*, Ph.D. Thesis, Martin-Lutter Universität, Halle-Wittenberg, Germany, 1998

Plan for the Talk

- ① Scope
- ② Progress in Computer-Aided Process Operation
 - Technology and (vs.) theory
 - Prevailing bottlenecks
- ③ Capturing and representing the knowledge
 - Forms of knowledge and modelling approaches
- ④ Model-based and Hybrid methods for process monitoring and control
- ⑤ Case-studies
 - Software sensors - mechanistic and hybrid approaches
 - Hybrid modelling and process control
- ⑥ Some concluding thoughts
 - The Human factor - investment, knowledge and industrial structure

Progress in computer-aided process operation

About the (old) gap between theory and practice

The development of new or improved forms of process operation is only successfully achieved when



It is possible to match theoretical innovation with the technology available for implementation at industrial scale

**Advances in digital technology
paved the way for a new area of interest**

Computer-Aided Process Operation

Computer-Aided Process Operation Interdisciplinary View

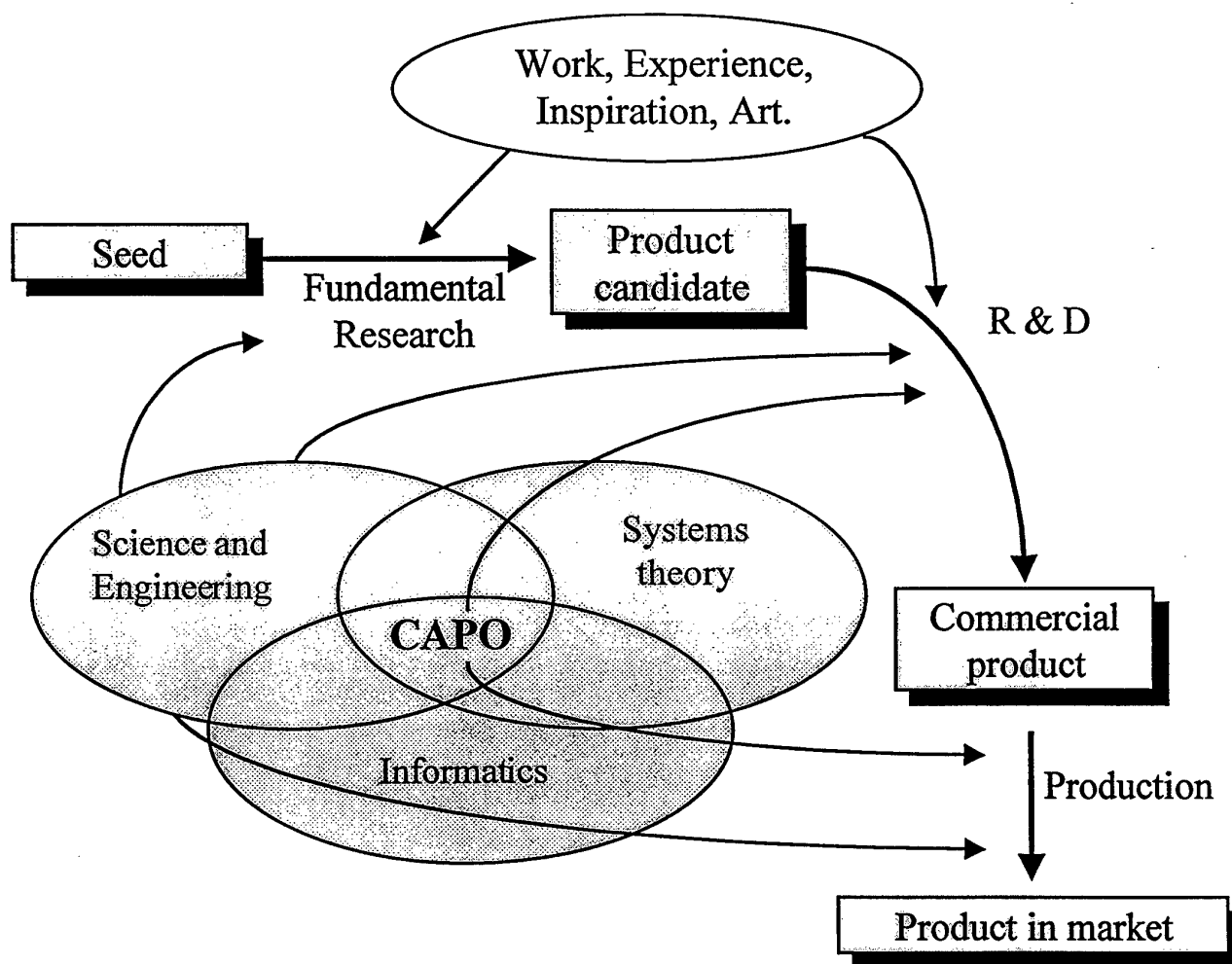

Progress in computer-aided process operation

I - identification of areas of interest

- ⇒ Progress in digital technology -
 - sensorsand
 - control systems

- ⇒ Progress in theory -
 - in process modelling and controlor, wider
 - in process systems engineering

- ⇒ Concern with the Human Factor, as a limiting step in the pace of development-
 - new expertise in the production team
 - organizational changes in Companies

Progress in computer-aided process operation

II - process measurements

- ☞ Sensors and analytical instruments are the primary elements for process monitoring
 - In spite of the observed progress in measurement technology -
 - To a large extent the technological **bottleneck** is in process measurements

At present -

- indirect measurements are still required for important properties.

Serving as example, not yet achieved -

- reliable direct measurement of crystal size distribution in industrial crystallisation
- or
- measurement of biomass in fermentation processes

Progress in computer-aided process operation III - industrial control systems

- ☞ A landmark in the history of CAPO has been reached at the close of the eighties

- ☞ Nowadays, control systems suppliers offer open architecture, standard operating systems and employ standard communications protocols, allowing -
 - programming with high level languages

 - and

 - integration of USER-TAILORED applications

Evolution in Computer Control Systems and Control Systems Architectures

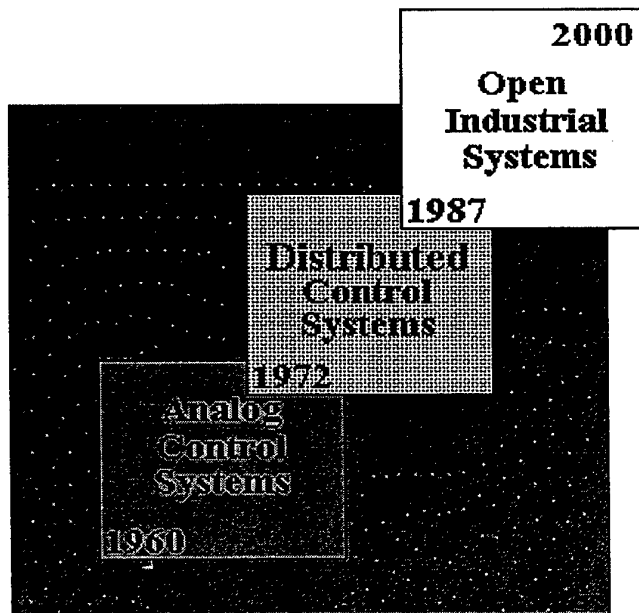
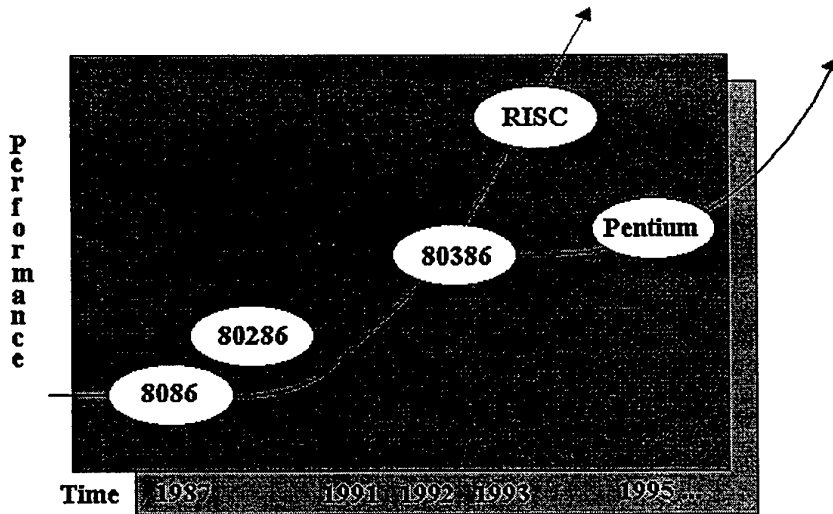

Progress in computer-aided process operation IV - Towards model-based methodologies

- ☞ Model-based methodologies:
- Re-thinking of concepts on capturing and representing process knowledge
 - Employing knowledge engineering approaches
 - Employing hybrid approaches - Combining different forms of knowledge through some (more or less) 'fuzzy' decision
 - Mechanistic models
 - Empirical models
 - Artificial neural networks
 -

Progress in computer-aided process operation

V - Process measurement and control

☞ Process measurements - Software sensors based on

- Mechanistic models
- Artificial neural networks
- Hybrid models

☞ Process control

- Significant progress in conventional control
- Model Based Process Control (MBPC)
 - Model reference adaptive control
 - Model based (adaptive)-predictive control
- Hybrid approaches for process control
- Real time knowledge based systems (RTKBS)

Capturing and representing process knowledge

I - forms of knowledge

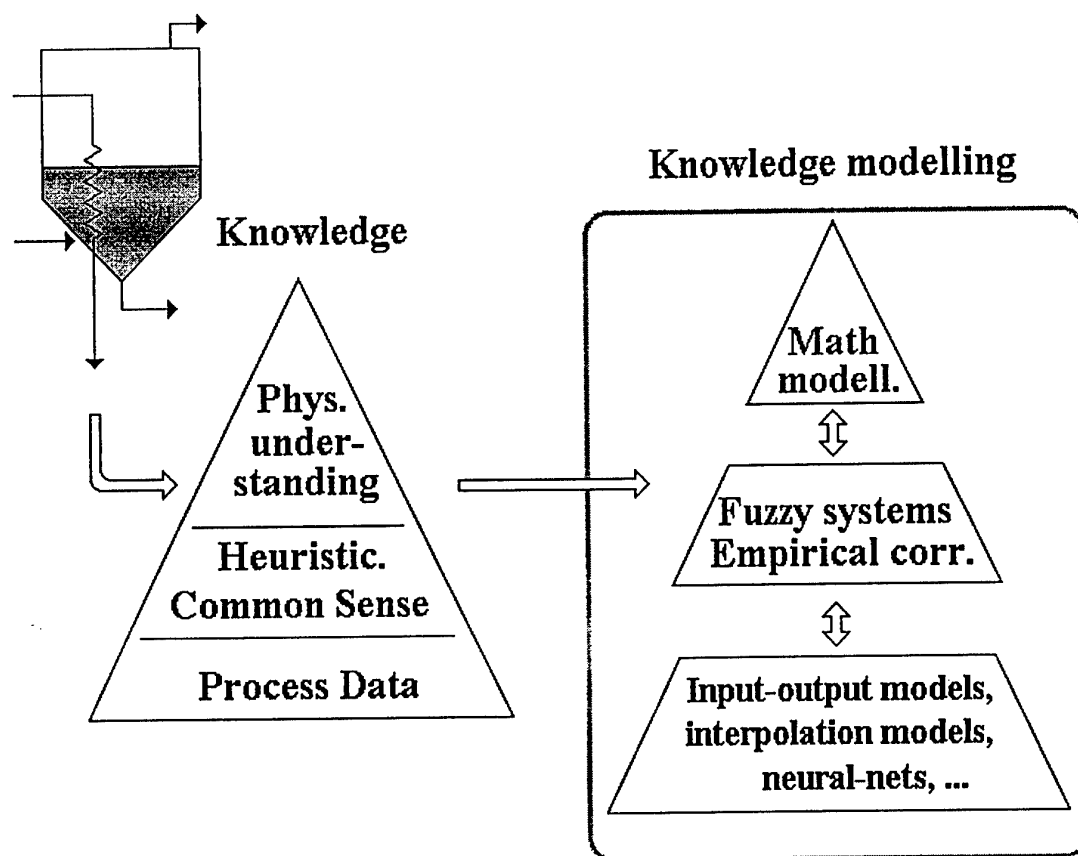

Capturing and representing process knowledge II - modelling approaches

- ☞ Mechanistic (first principles) models

$$\frac{d\xi}{dt} = r(\xi) - D\xi + F - Q(\xi)$$

- ☞ Input-output (stochastic) models

$$A(q^{-1}) y(t) = B(q^{-1}) u(t) + C(t) \omega(t)$$

where

$$q^{-1} y(t) = y(t-1) \quad \Leftarrow$$

e.g.: Level control (h) with Outlet Flowrate (Q)

$$\hat{h}_k = \sum_{i=1}^2 a_i h_{k-i} + \sum_{j=1}^2 b_j Q_{k-j}$$

Capturing and representing process knowledge II - modelling approaches (cont.)

☞ AI models

eg.: Jordan Neural-Net

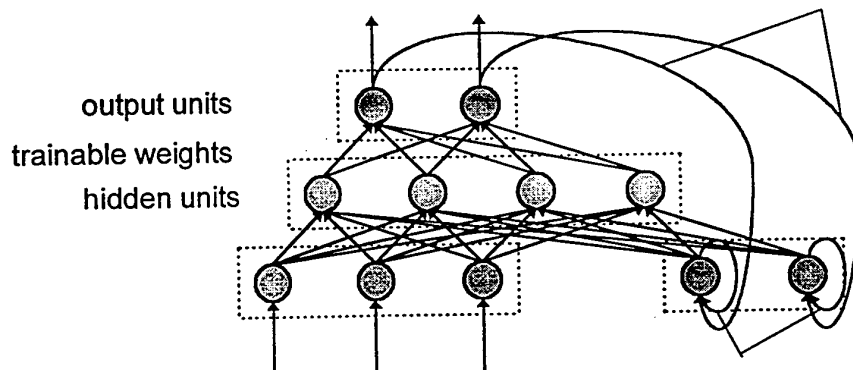

☞ Hybrid models (Mechanistic + ANN and/or Fuzzy and/or RTKBS)

- Capturing hidden knowledge and avoiding violation of first principles

Bottleneck - lack of reliable measurements

☞ A topic in the front line of concern is that of -

○ monitoring the behaviour of internal process variables which define the so-called process state and for which direct measurements are either -

not available,

difficult,

expensive

or inaccurate

☞ **Software sensors** - a concept to overcome such difficulties

Software sensors and on-line state estimation

I - general

- ① The concept of 'software sensors' is a major development, made possible by computers, towards the objective of full monitoring of process operation.

- ② In general, 'software sensors' should be seen as a method by which with a minimum number of direct measurements we are able to fully describe the process state at any point of operation.

Software sensors and on-line state estimation II- based on mechanistic models

- ③ Often 'software sensors' consist only in the manipulation of simple algebraic relationships.



That is the case for supersaturation in crystalization processes.

- ④ In other instances, the 'sensor' requires the use of the full deterministic model.

- Usually one should look for some form of transformation which eliminates the 'less accurately known' terms in the model.



Invariably these are 'kinetic rate' terms

Software sensors and on-line state estimation III- based on ANN or Hybrid approaches

- ⑤ In other cases 'black-box' approaches are employed.



This raises major questions of confidence on results outside training areas

- ⑥ Hybrid solutions involving mechanistic models and ANN may represent a good solution for the applied problem



Capturing hidden knowledge and avoiding violation of first principles

Modelling and Control of Fermentation Processes

- ☞ Cooperation with
 - ☐ University of Minho, Braga, Portugal
 - ☐ Martin-Luther University, Halle-Wittenberg, Germany
 - ☐ CESAME, Louvain-la-Neuve, Belgium

- ☞ General objectives - modelling and control of biological reactors
 - ☐ Major difficulties related with the 'unpredictable' behaviour of biological systems

 - ☐ Significant difficulties when applying mechanistic models 'only'

 - ☐ AI methods for capturing knowledge

 - ☐ Looking into hybrid solutions

Basic concepts

Mechanistic model for fermentation processes

☞ Let us consider a production process involving *microbial growth*

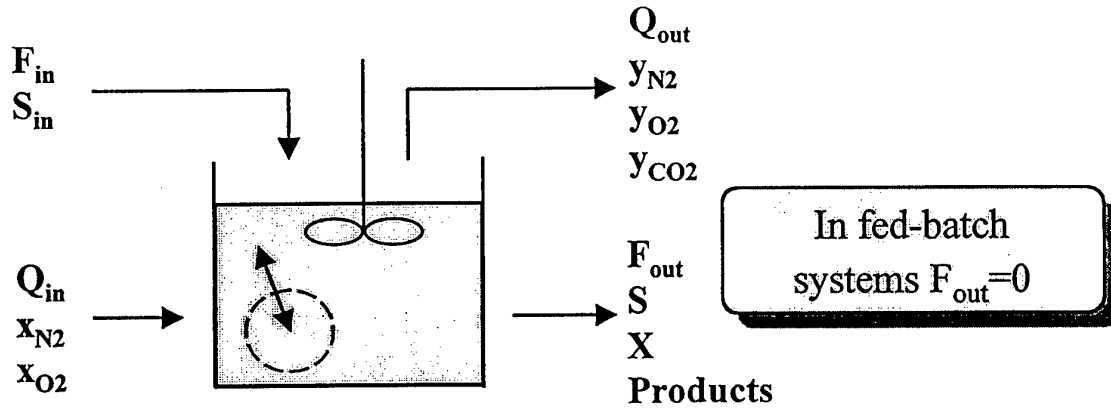

☐ e.g.: Mass balance to substrate

$$F_{in}S_{in} = F_{out}S + r_S V + \cancel{STR} + \frac{d(VS)}{dt}$$

and $\frac{dV}{dt} = F_{in} - F_{out}$

☐ Expanding and re-arranging

$$\frac{dS}{dt} = -r_S - DS + DS_{in}$$

where $D = \frac{F_{in}}{V} \Rightarrow$ Dilution rate

Mechanistic model for fermentation processes (cont.)

☞ The case of **Baker's yeast production**

<input type="checkbox"/> We feed in	<input type="checkbox"/> Production of
<input type="radio"/> Substrate	<input type="radio"/> Biomass
<input type="radio"/> Air	<input type="radio"/> Ethanol
	<input type="radio"/> Carbon dioxide

and we can write the model

$$\frac{d}{dt} \begin{matrix} X \\ S \\ E \\ O \\ C \end{matrix} = \begin{matrix} -r_X \\ -r_S \\ -r_E \\ -r_O \\ -r_C \end{matrix} - D \begin{matrix} X \\ S \\ E \\ O \\ C \end{matrix} + \begin{matrix} 0 \\ DS_{in} \\ 0 \\ OTR \\ 0 \end{matrix} - \begin{matrix} 0 \\ 0 \\ 0 \\ 0 \\ CTR \end{matrix}$$

with

$$OTR = K_{e_{O_2}} a [O^* - O] \quad O^* > O$$

$$CTR = K_{e_{CO_2}} a [C^* - C] \quad C > C^*$$

☞ OTR and CTR can be estimated on-line from mass balances to the system

**General problem:
cell systems are extremely complex!**

- ✓ A full mathematical description of cells metabolism (cell level and population level) is too complex

- ✓ Available segregated and structured cell models are at the moment “out of range” for bioprocess optimization

- ✓ Hybrid models:
 - Disadvantage: Hybrid models are of considerable complexity \Rightarrow require sophisticated software tools and computation power

General Dynamical Model for Fermentation Processes

$$\frac{d\xi}{dt} = r(\xi) - D\xi + F - Q(\xi)$$

$$r(\xi) = ?$$

$$r(\xi) = K \varphi(\xi)$$

$$r(\xi) = K H(\xi) \rho(\xi)$$

Advanced Monitoring

Software sensors / State estimation

(Bastin & Dochain, 1990)

$$\frac{d\xi}{dt} = K\varphi(\xi, t) - D\xi + U \quad \xrightarrow{= F - Q} \quad \begin{array}{l} \text{2 state partitions:} \\ \xi_1 \in \mathbb{R}^p \text{ and } \xi_2 \in \mathbb{R}^{n-p} \end{array}$$

On-line estimation of ξ_2 , given :

- ✓ φ unknown
- ✓ p measured state variables (ξ_1)
- ✓ D, U (F, Q) measured on-line
- ✓ coefficients of K known

$$\frac{d\xi_1}{dt} = K_1\varphi - D\xi_1 + U_1$$

$$\frac{d\xi_2}{dt} = K_2\varphi - D\xi_2 + U_2$$

Make: $Z = A\xi_1 + \xi_2$ where $AK_1 + K_2 = 0$

Get: $\frac{dZ}{dt} = -DZ + AU_1 + AU_2$ ↘
Got rid of φ !!!

Advanced Monitoring Software sensors / State estimation (cont.)

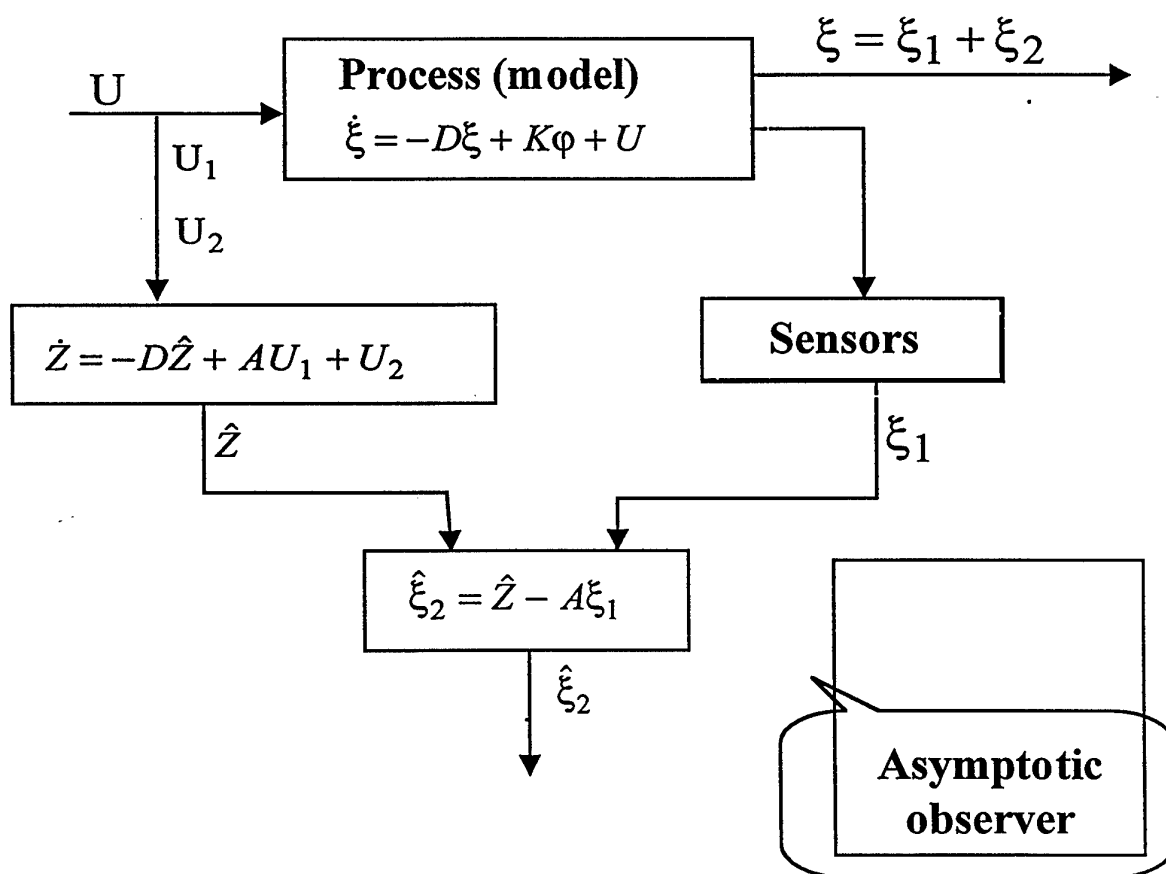

Model-based state observer for Baker's Yeast fermentation - I

- Estimation of OTR e CTR by mass balances to the gas phase
- Partial kinetics models

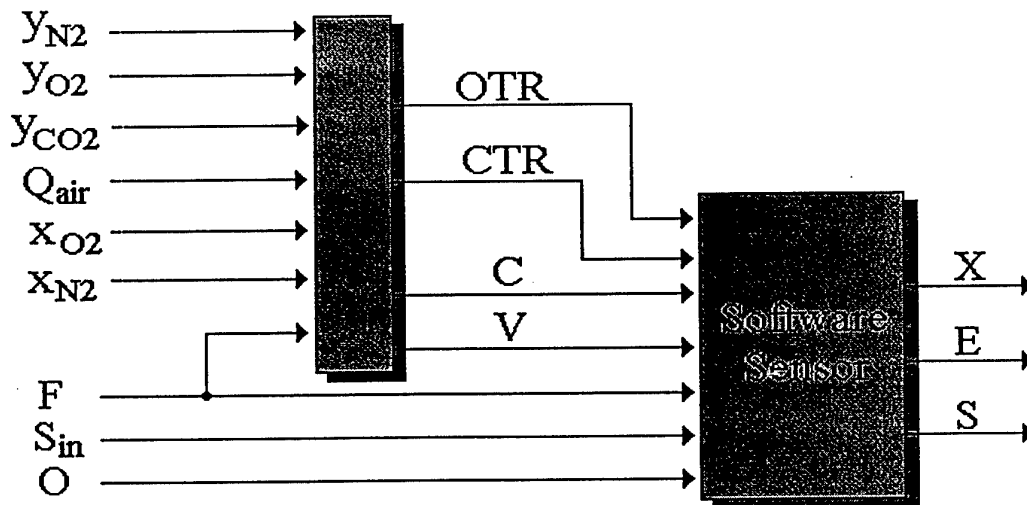

□ Sampling rate = 6 min

State observers and PID control (simulation)

- Conditions

- $E_0=0.8$ g/l; $S_0=1.3$ g/l; $X_0=0.3$ g/l;
- $V_0=2$ l; $F_0=0$ l/hr; $S_{in}=30$ g/l;
- $K_c=2.5$ (l/hr)/(g/l); $\tau_I=0.5$ hr; $\tau_d=0.05$ hr

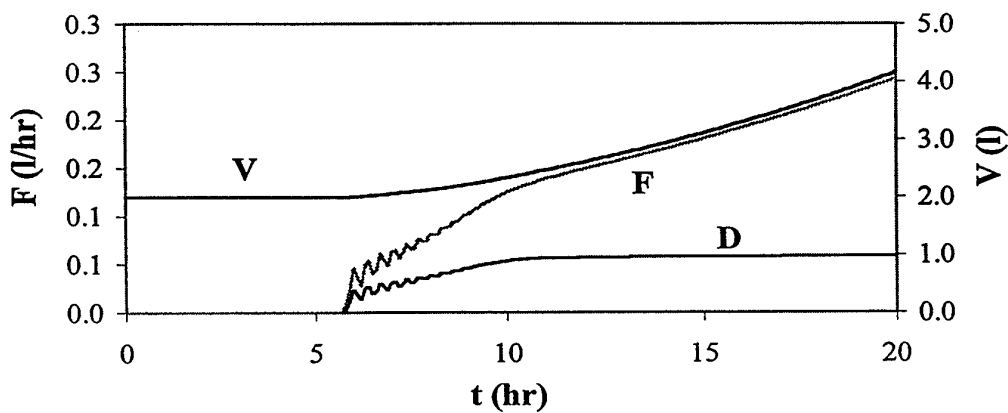
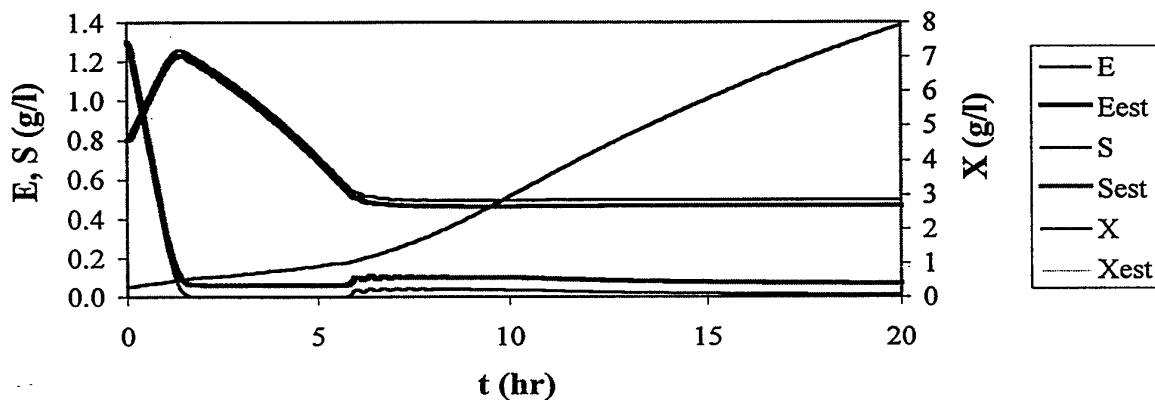

Model-based state observers (experimental)

- Operating conditions:
 - $S_{in} = 100$ g/l; $F = 0.15$ l/hr; $V_0 = 2.5$ l

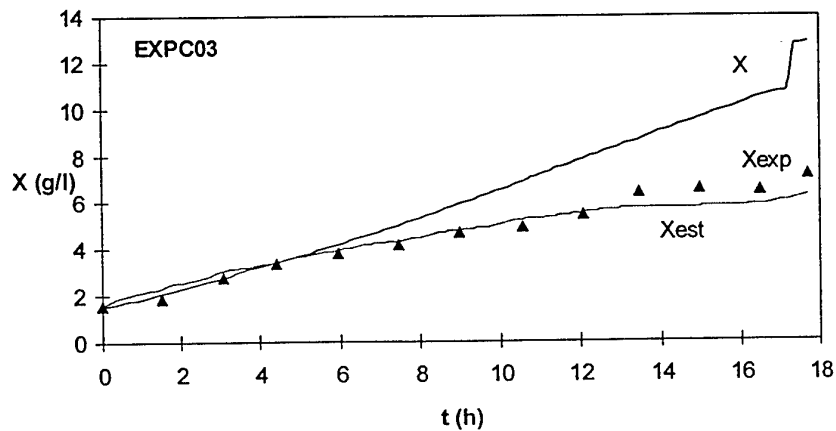
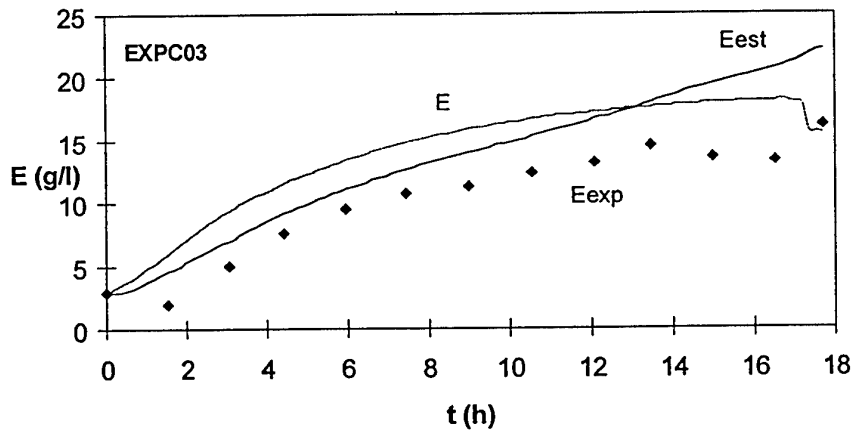

Hybrid modelling of fermentation processes - I

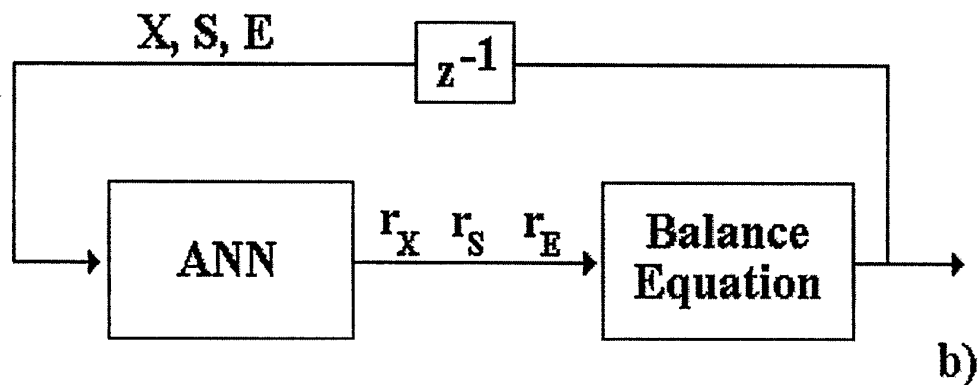
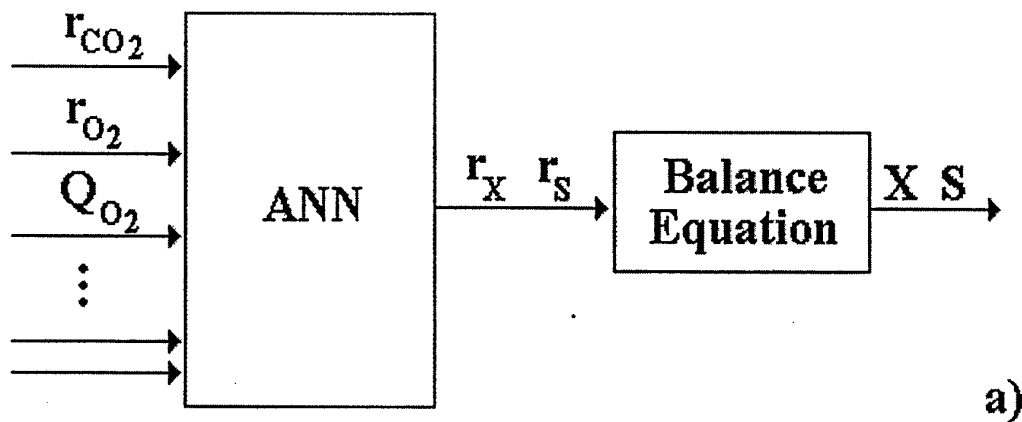

Hybrid modelling of fermentation processes - II Monitoring ANN performance

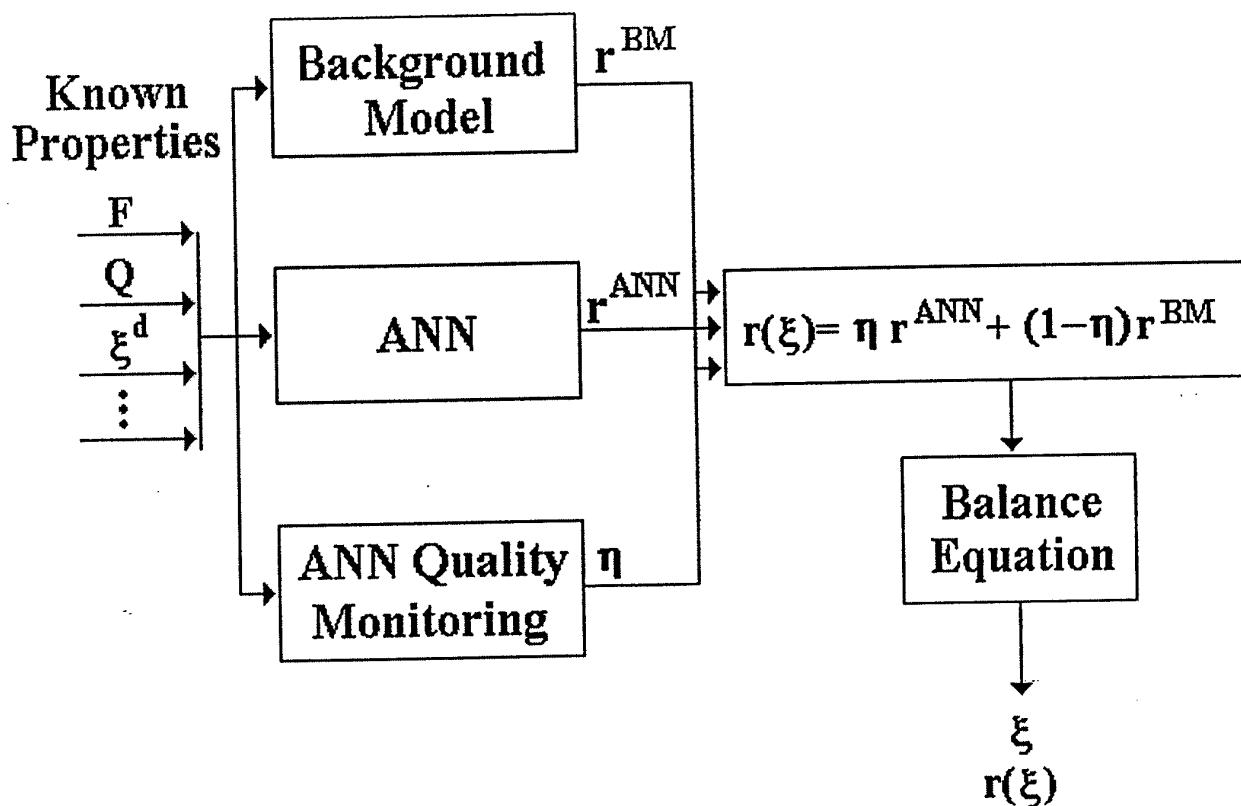

Hybrid modelling of fermentation processes - III

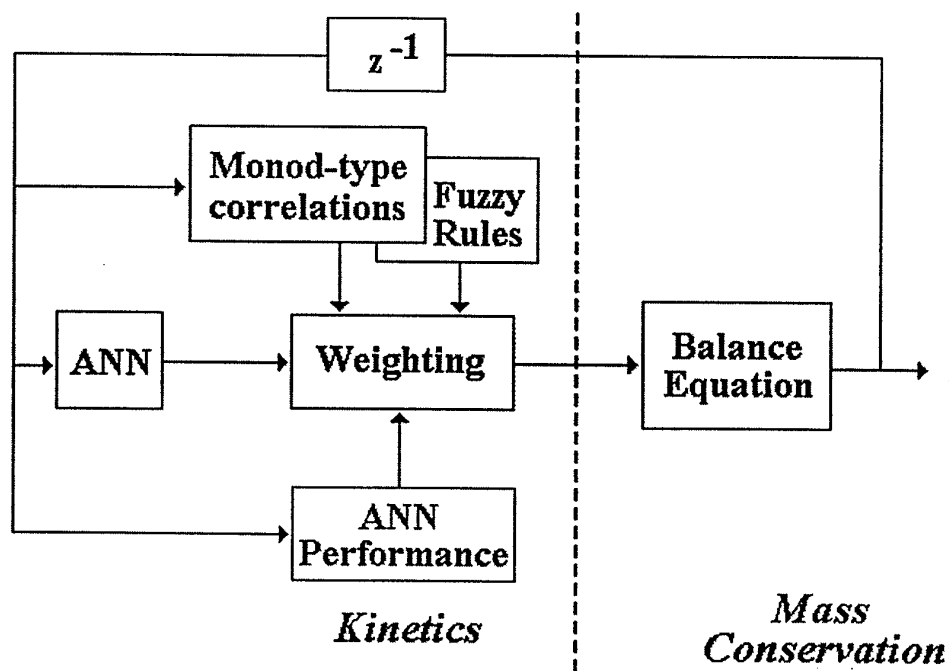

Hybrid Modelling Case-Study with baker's yeast production I - Structure

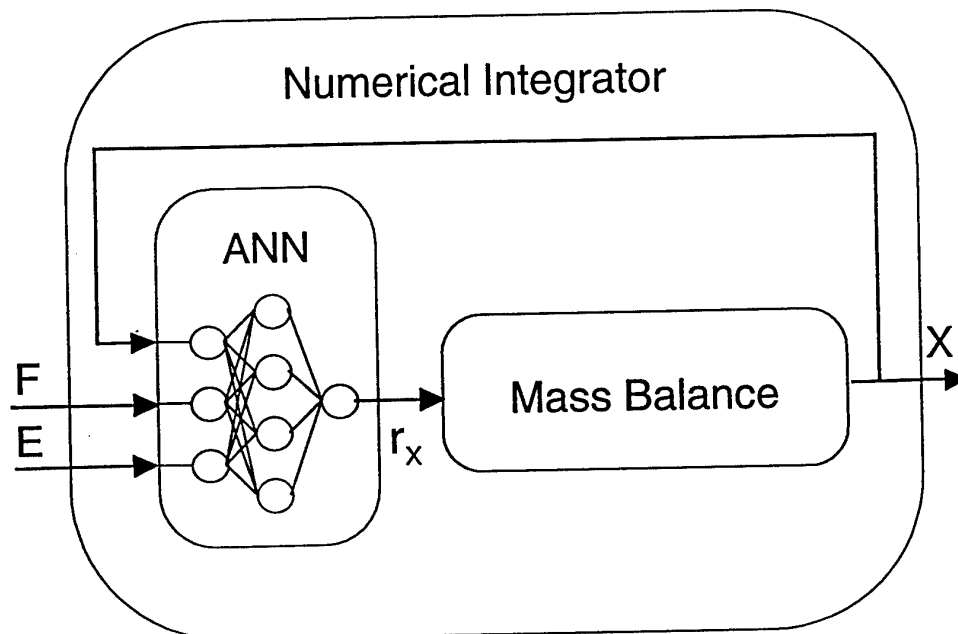

Hybrid Modelling

Case-Study with baker's yeast production

II - Neural-networks employed

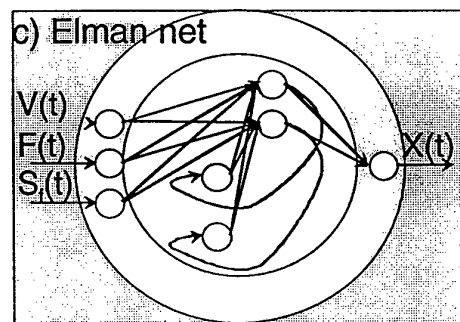
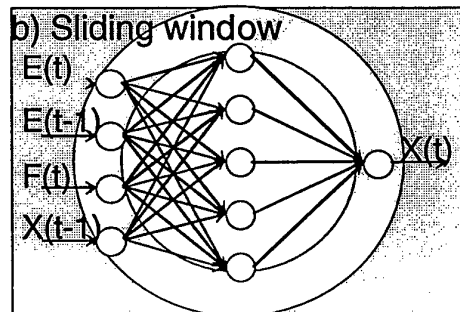
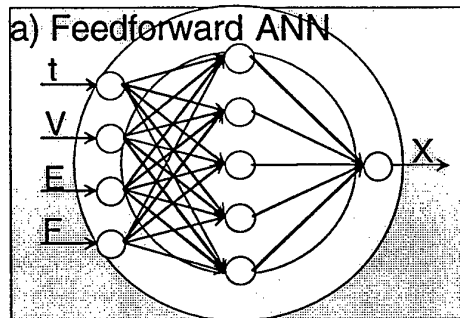

Hybrid Modelling

Case-Study with baker's yeast production

III - Predictions with mechanistic model

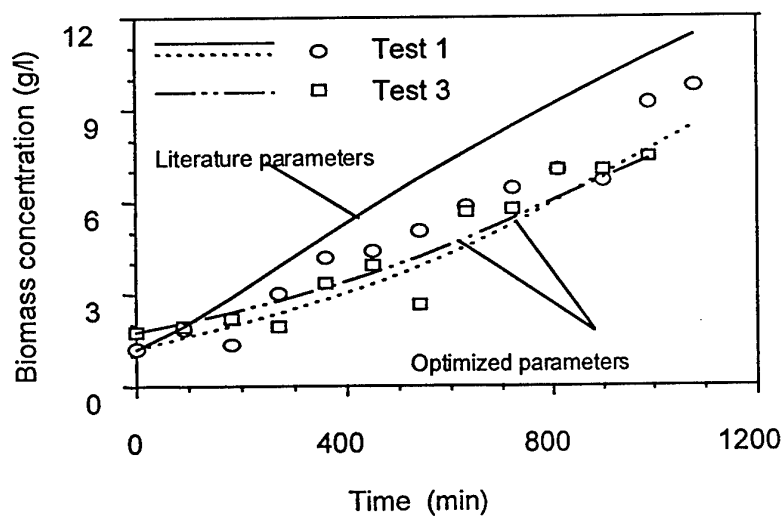

Hybrid Modelling

Case-Study with baker's yeast production

IV - ANN and hybrid model training

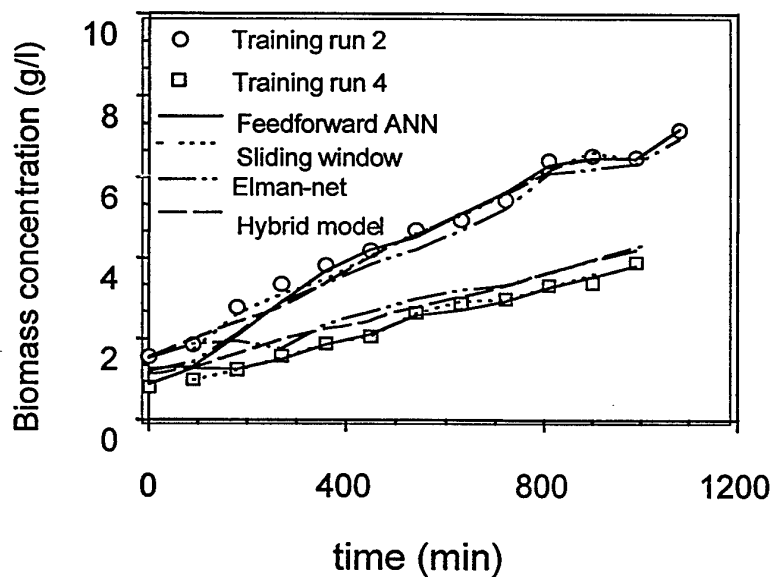

Hybrid Modelling

Case-Study with baker's yeast production V - Pure ANN test

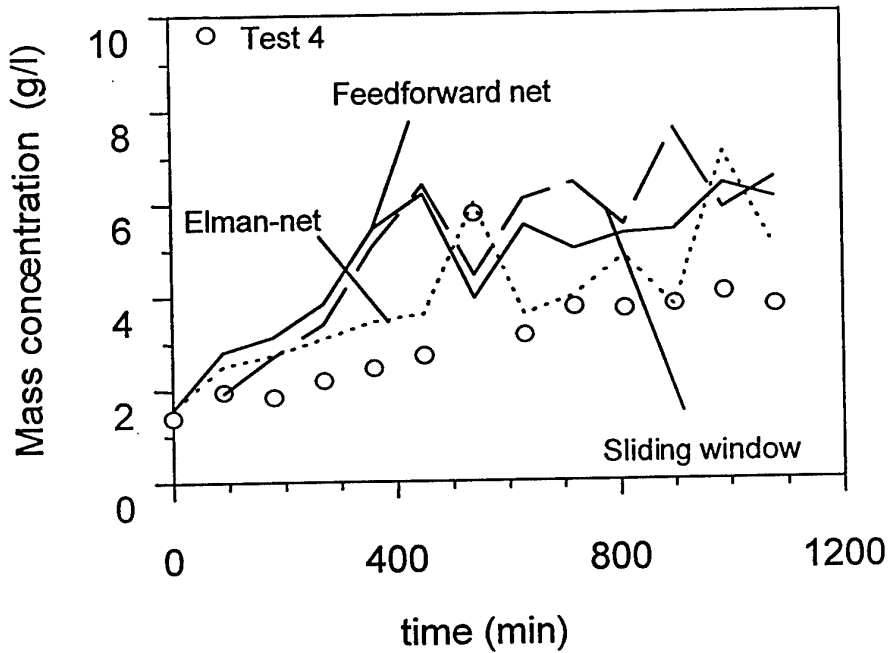

Hybrid Modelling

Case-Study with baker's yeast production

VI - Test: pure ANN versus HM

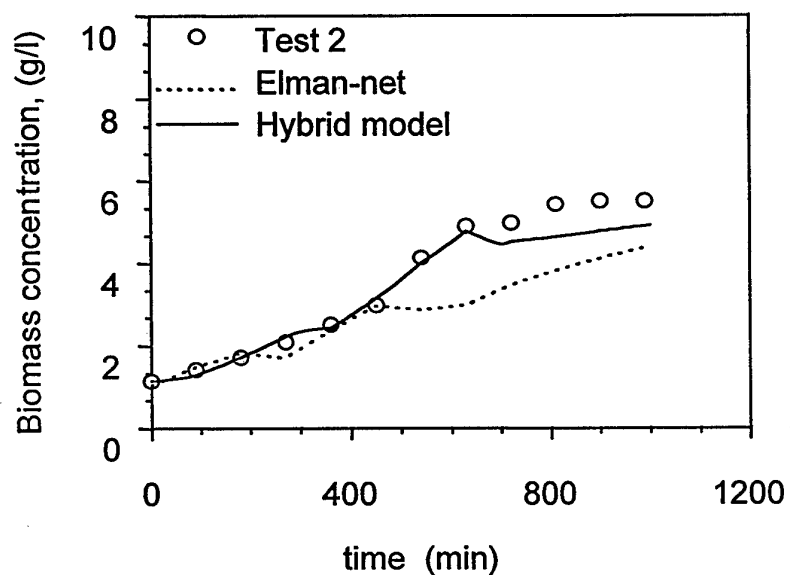

Hybrid Modelling

Case-Study with baker's yeast production

VII - Testing of hybrid model

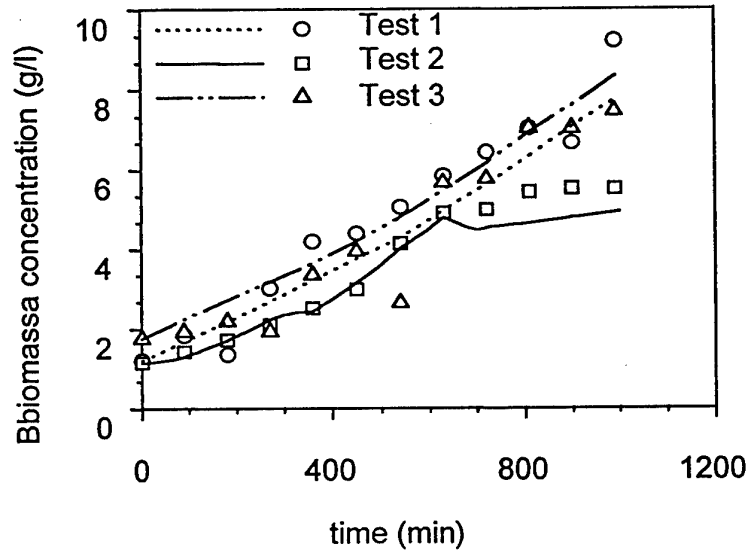

Case-study: Penicillin production process

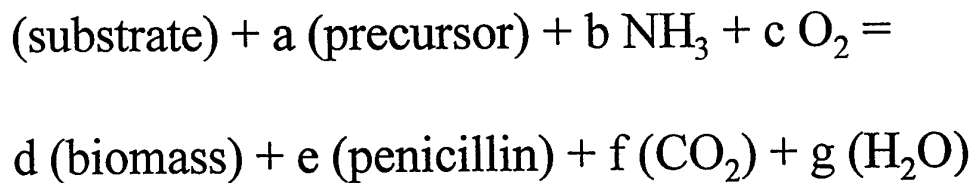

- ✓ **N manipulatable variables**
- ✓ Power input (Air flow, Agit.)
- ✓ Initial medium composition
- ✓ operation: batch, fed-batch, pulse
- ✓ Input flow rates of several components
- ✓ Rate of heat removal
- ✓ Fermentation time

Φ

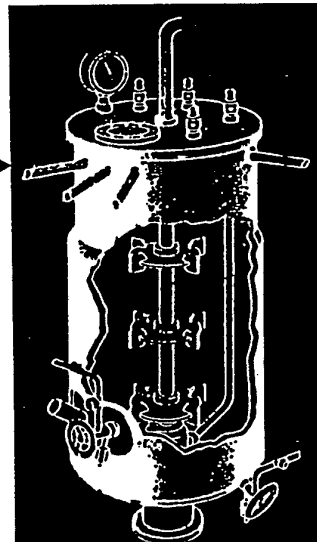

► **J**

Process performance index (J)

- Productivity
- Product quality

Model-based open-loop control

Trial-and-error

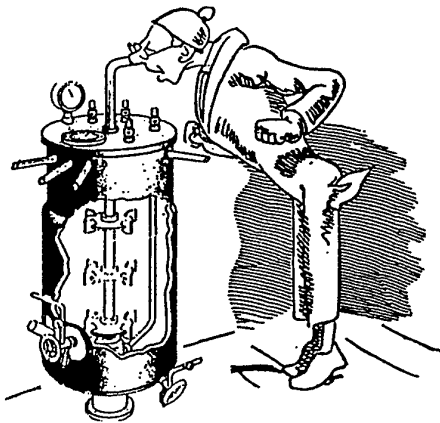

- Empirical method: intuition and experience.
- Good luck is an essential condition to be successful in this way.
- Slow process improvement
- More experiments

Model-based

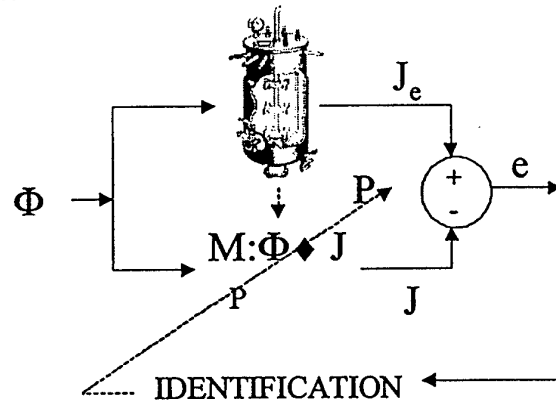

- ✓ Identification:
 - Model \equiv Process
- ✓ Optimisation:
 - Φ_{opt} calculated analytically or numerically

$$\max_{\Phi} (J(\Phi, P)) \quad \Phi_{opt}$$

Automatic control of ammonia and side chain precursor concentrations in a penicillin production process

- ✓ The concentrations of ammonia (C_N) and side chain precursor (C_{PA}) in the broth have a great influence on the penicillin productivity of a given strain.
- ✓ In most industries this control is performed manually by feeding a solution of ammonia (F_N) and precursor (F_{PA})
- ✓ The measurements of C_N and C_{PA} are difficult and expensive. Measurements are made off-line with low frequency.

Penicillin biosynthesis

Ammonia

- high affinity uptake at low concentrations
- low affinity uptake at high concentrations

Side chain precursor

- toxic at high concentrations
- stimulates the synthesis of penicillin (about 5-fold by penicillin G)

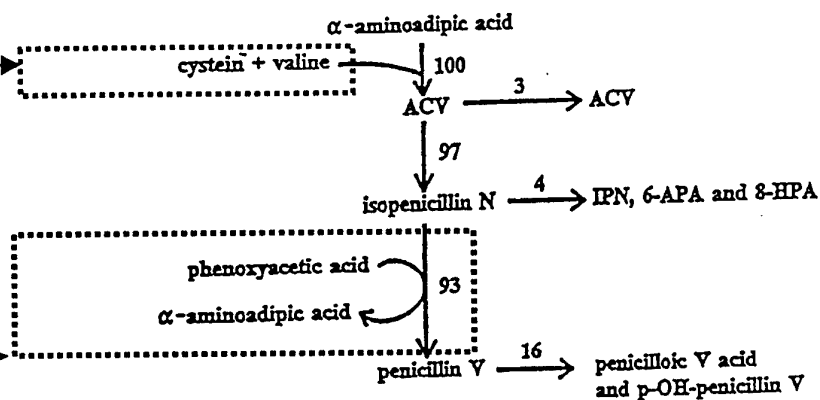

✓ Ammonia and side chain precursor concentrations must be kept constant at optimal values for maximum penicillin productivity!

Experimental evidence -dependency of specific penicillin production rate (π) on (C_N) and on (C_{PA})

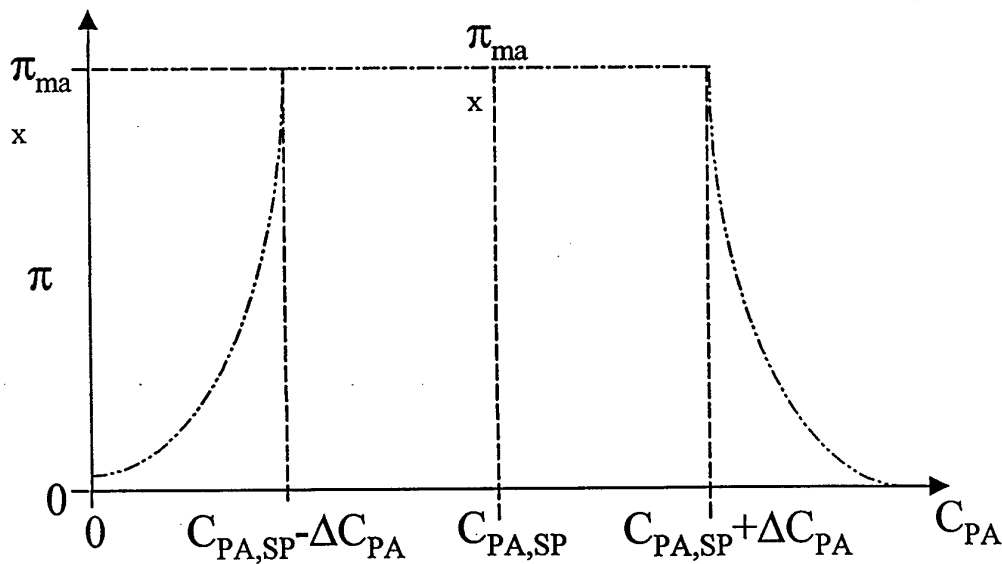
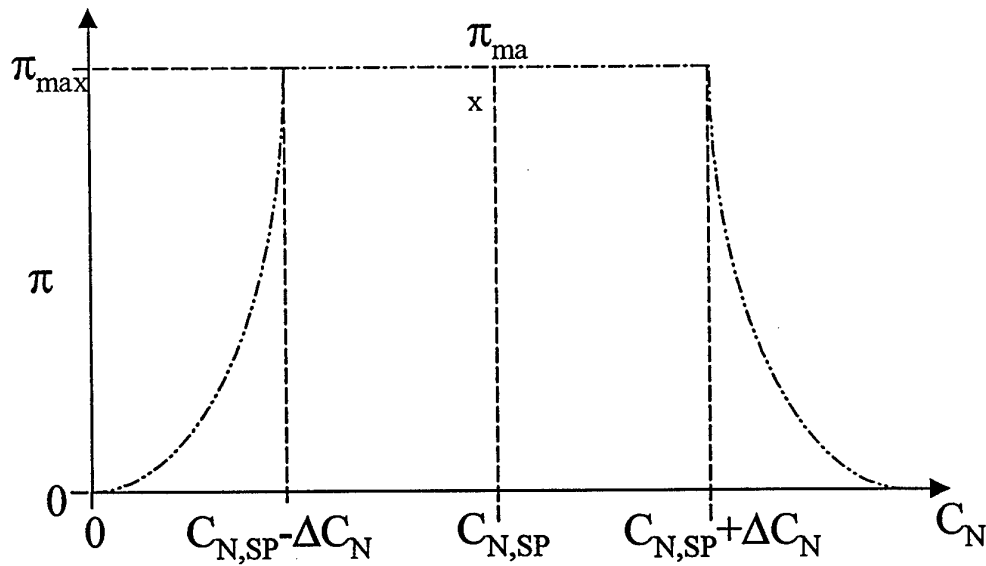

Manual empirical control

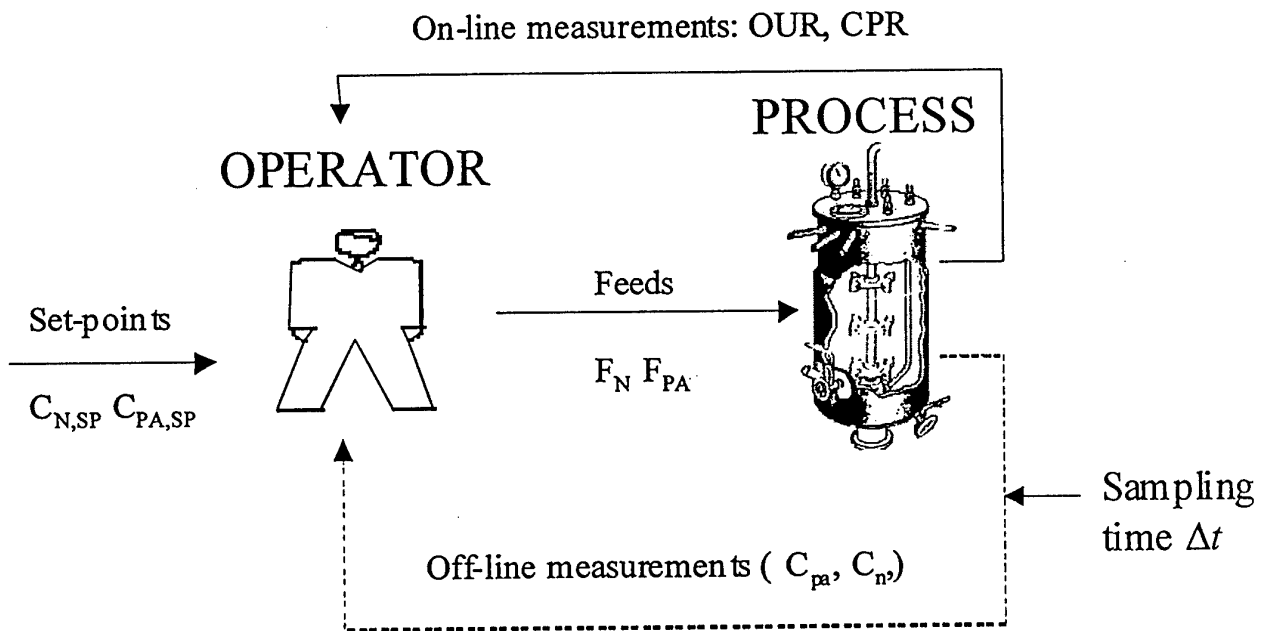

- ✓ Expensive off-line measurements (high Δt)
- ✓ Classical (PID) control not feasible
 - Manual control

Manual empirical control (12 Fermentations)

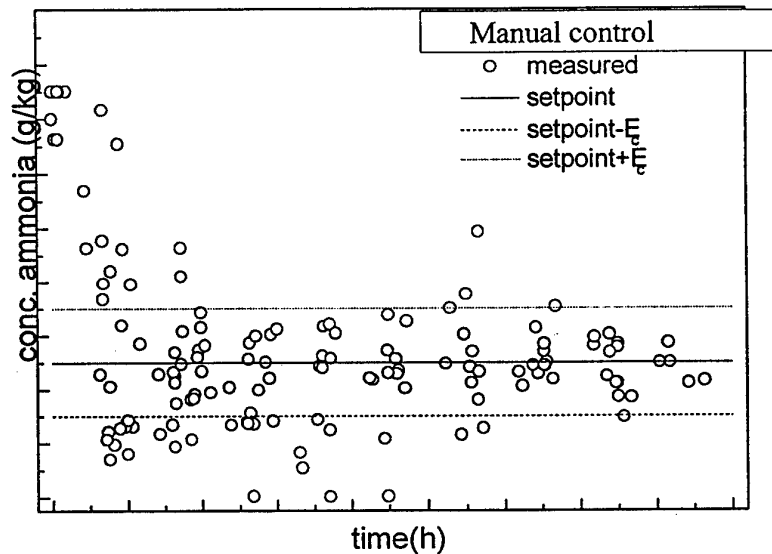

Figure 1. Concentration of ammonia for 12 fermentations controlled manually

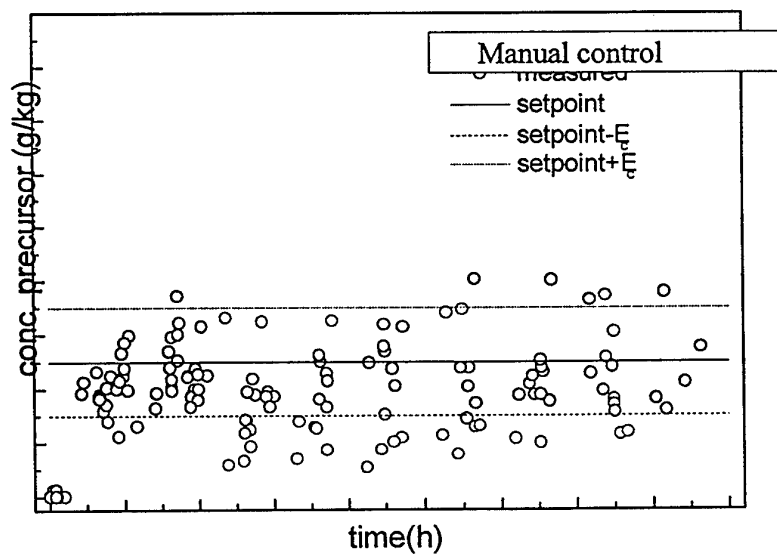
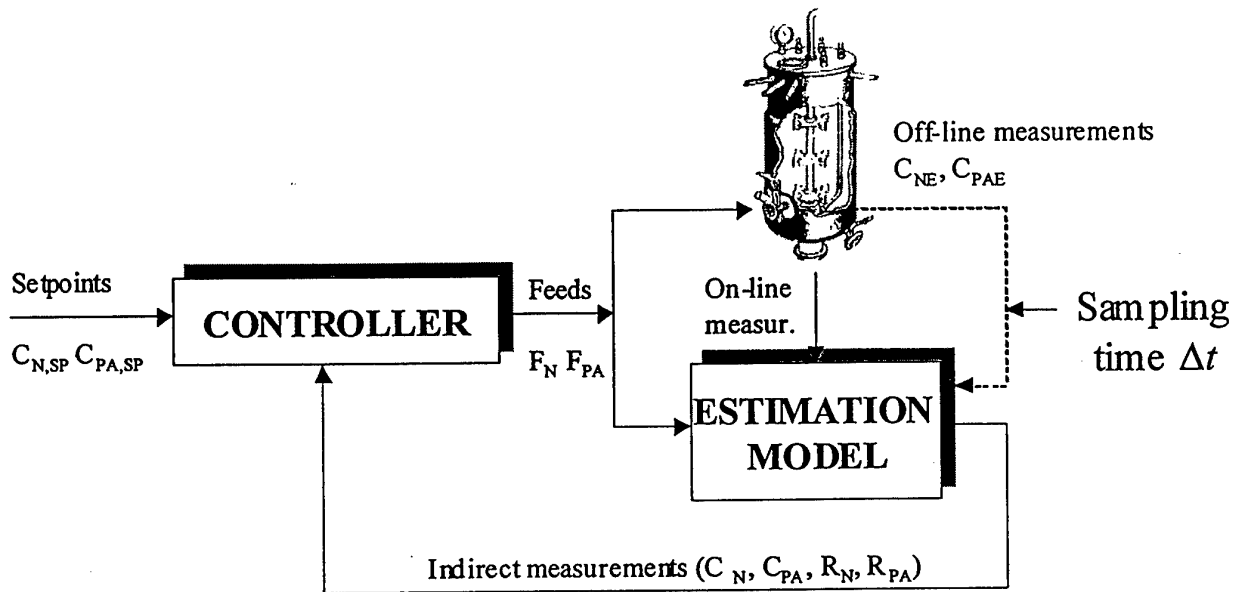

Figure 2. Concentration of precursor for 12 fermentations controlled manually

Inferential control system



- ✓ Estimation (or prediction) model for the concentrations of ammonia and precursor between off-line measurements

Macroscopic mass balance to the fermenter

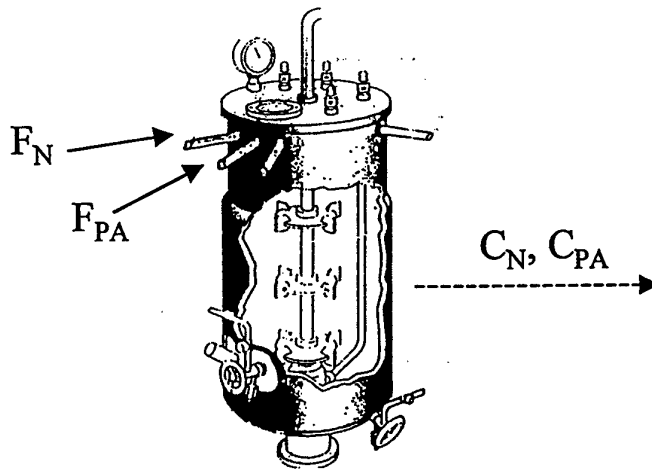

$$\frac{dC_N}{dt} = \underbrace{-R_N}_{\text{Production rate}} + \underbrace{\frac{F_N}{W} C_{FN}}_{\text{Input feed rate}} - \underbrace{\frac{F_{tot}}{W} C_N}_{\text{Dilution rate}}$$

$$\frac{dC_{PA}}{dt} = \underbrace{-R_{PA}}_{\text{Production rate}} + \underbrace{\frac{F_{PA}}{W} C_{FPA}}_{\text{Input feed rate}} - \underbrace{\frac{F_{tot}}{W} C_{PA}}_{\text{Dilution rate}}$$

Accumulation rate

Production rate

+ Input feed rate

- Dilution rate

ASSUMPTION: Well-mixed bioreactors
KINETIC MODEL = ?

ANN-Kinetic Model

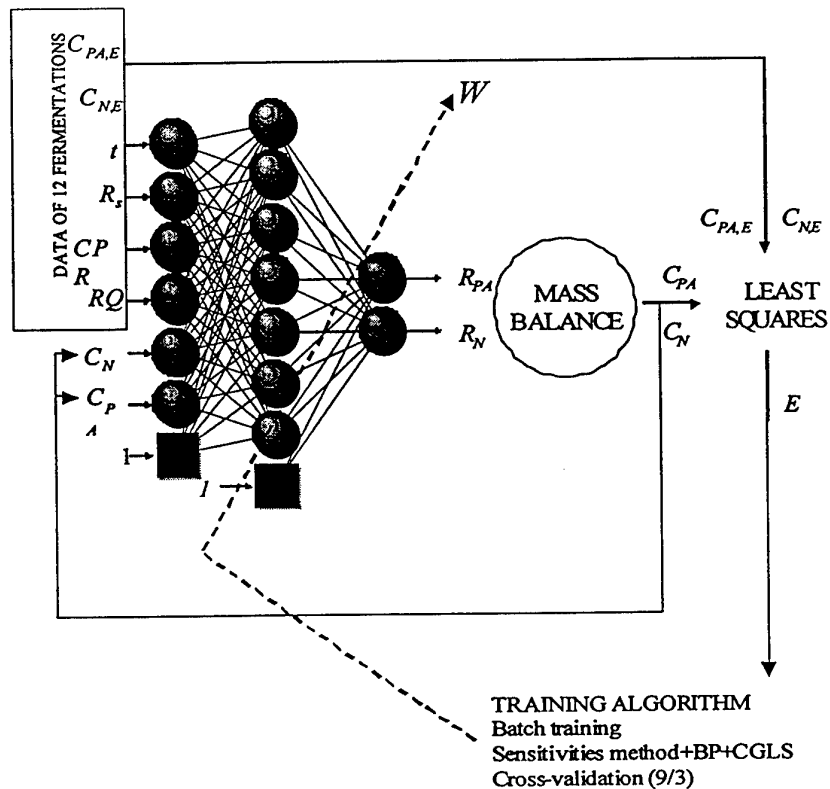

- ✓ Feedforward ANN {6,7,2}
- ✓ 65 ANN parameters ($\dim(W)=65$)
- ✓ 9 Fermentations for training (8137 experimental points)
- ✓ 3 Fermentations for validation (2311 experimental points)

BP - Backpropagation; CGLS - Conjugate Gradients with Line-Search

Training algorithm

Objective function: minimization of precursor and ammonia estimation errors according to a batch least-squares criterion (P - number of total measured points):

$$E = \left(\frac{1}{P} \sum_{t=1}^P \left([\alpha(C_{PAE}(t) - C_{PA}(t))]^2 + [\beta(C_{NE}(t) - C_N(t))]^2 \right) \right)^{\frac{1}{2}}$$

The objective function gradients are obtained by differentiating the previous equation with respect to the ANN parameters vector (W)

$$\frac{\partial E}{\partial W} = -\frac{1}{E P} \sum_{t=1}^P \left(\alpha(C_{PAE}(t) - C_{PA}(t)) \frac{\partial C_{PA}(t)}{\partial W} + \beta(C_{NE}(t) - C_N(t)) \frac{\partial C_N(t)}{\partial W} \right)$$



$\partial C_{PA}/\partial W$ and $\partial C_N/\partial W$ is calculated with the sensitivities method

$$\frac{d\left(\frac{\partial C_N}{\partial W}\right)}{dt} = -\left(\frac{\partial R_N}{\partial C_N} + \frac{F_{tot}}{W}\right) \frac{\partial C_N}{\partial W} - \frac{\partial R_N}{\partial C_{PA}} \frac{\partial C_{PA}}{\partial W} - \frac{\partial R_N}{\partial W}$$

Initial conditions: $(\partial C_N/\partial W)_{t=0}=0$ and $(\partial C_{PA}/\partial W)_{t=0}=0$

$\partial R_N/\partial C_{PA}$, $\partial R_N/\partial C_N$ and $\partial R_N/\partial W$ are calculated by applying the backpropagation algorithm to the ANN

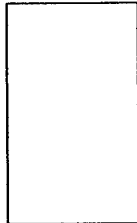
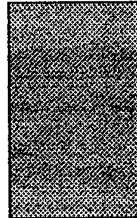
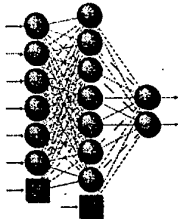
Comparison of different kinetic models (mean absolute estimation error) for 12 fermentations

		AMMONIA	PRECURSOR
$R_{PA} = \frac{aM_{PA}}{M_S} R_S = Y_{PA/S} R_S$ $R_N = \frac{17b}{M_S} R_S = Y_{N/S} R_S$		MECHANISTIC	$1.06 \Delta C_N$ $1.29 \Delta C_{PA}$
$f_c = \frac{R_x}{M_s} - CPR$ $R_N = a_1 f_c + b_1$ $R_{PA} = a_2(t) f_c + b_2(t)$		EMPIRICAL	$1.09 \Delta C_N$ $1.19 \Delta C_{PA}$
		BLACK-BOX	$0.53 \Delta C_N$ $0.80 \Delta C_{PA}$

✓ The ANN model gives best results for the ‘training data set’

Problem:

Neural Networks are unreliable in extrapolation conditions!

Measuring the reliability of the ANN Kinetics: Clustering

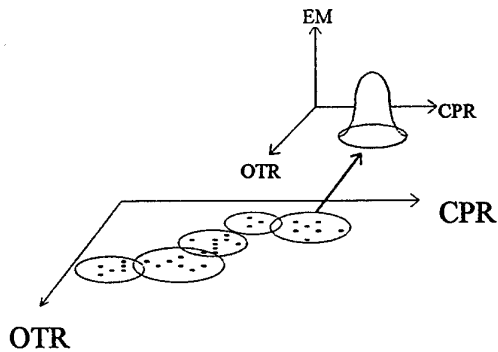

Fig. 1 - Clustering a set of points in a 2-dimensional data space $D = \{X_1, X_2, \dots\}$

Set of discrete points
(measurements)



Continuous density function
(extrapolation measure - EM)

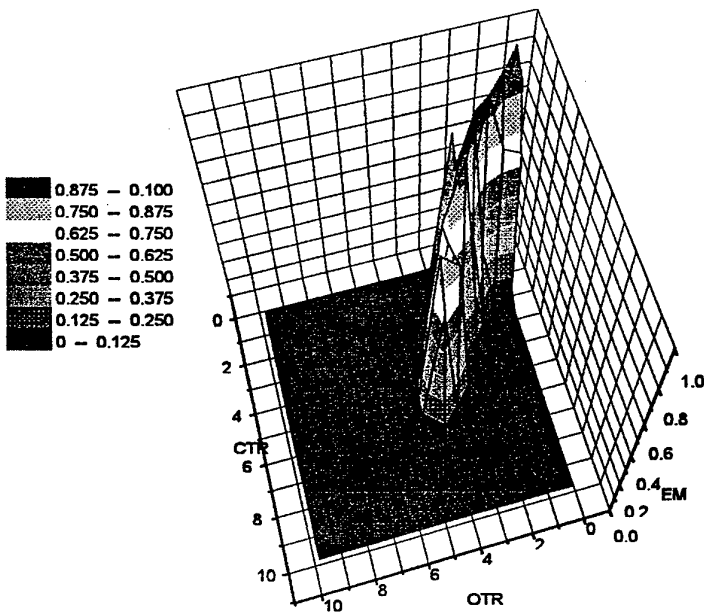

Fig. 2 - Continuous Probability distribution in a 2-dimensional space (Clusters-representation)

Clustering concept - I

✓ N measured input vectors:

$$\{X_j\} = \{x_1, x_2, \dots, x_N\} \subset \{X\}$$

✓ M clusters (multivariate gaussian distributions):

$$(M \leq N/3),$$

Cluster i , defined by -

c_i - vector defining the i th cluster center

σ_i - standard deviation

For a given work input vector x , define -

$$N_i(c_i, \sigma_i, x) = e^{-\|x - c_i\|^2 / \sigma_i^2}$$

✓ Extrapolation measure - EM:

$$EM(x) = \max(N_1(x, c_1, \sigma_1), N_2(x, c_2, \sigma_2), \dots, N_M(x, c_M, \sigma_M))$$

Clustering concept - II

✓ Clustering algorithm: vector \underline{c} , for $x \in \{X_j\}$:

$$E = \sum_{i=1}^N \min(\|x_i - c_1\|, \dots, \|x_i - c_C\|) \quad \min_{c_1, c_2, \dots, c_C}(E)$$

Algorithm: k-mean or adaptive k-mean (Lloyd (1957), MacQueen (1967))

✓ Standard deviation:

- either - uniform and heuristically defined
 - suggested - 1/10 of range
- or - algorithm *Global First Nearest-Neighbour*

Hybrid network estimation model

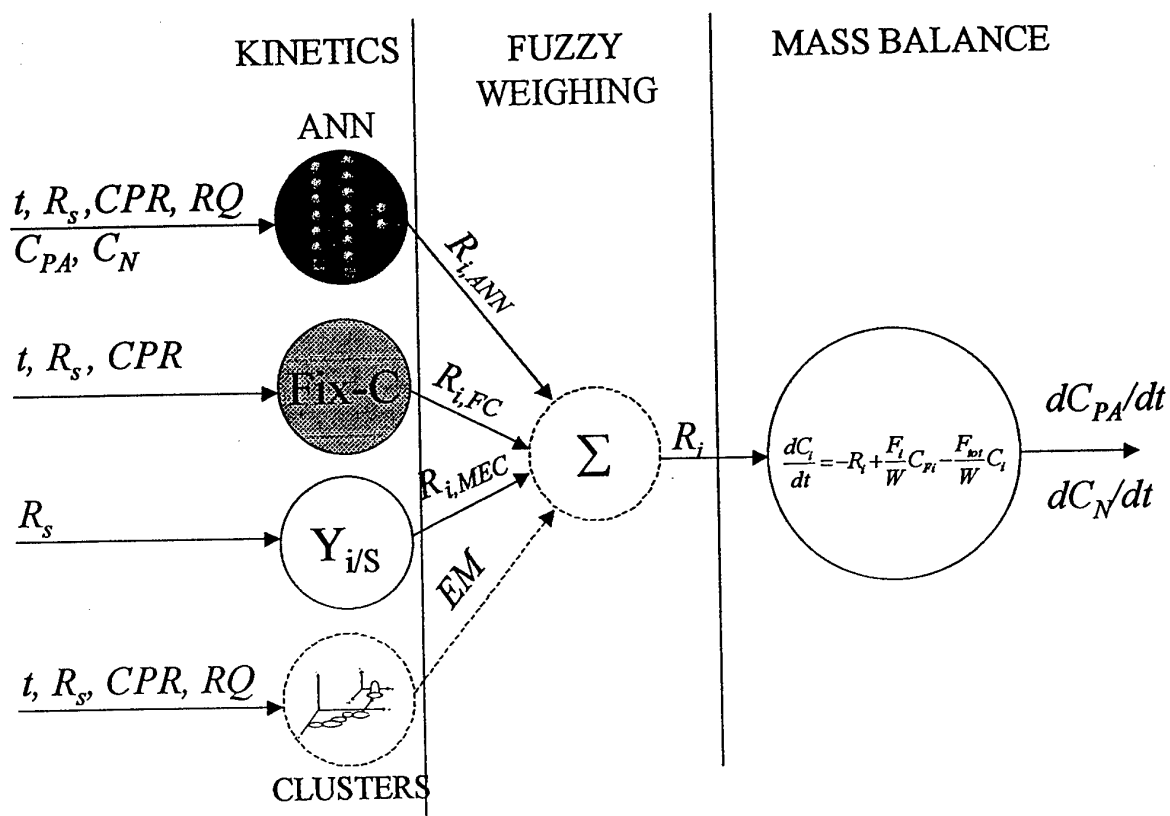

Fuzzy weighting node

Table II - Fuzzy rules

R_1 : IF (EM is LOW) THEN (W_{ANN} is LOW and W_{FC} is LOW and W_{MEC} is HIGH)

R_2 : IF (EM is MED) THEN (W_{ANN} is LOW and W_{FC} is HIGH and W_{MEC} is LOW)

R_3 : IF (EM is HIGH) THEN (W_{ANN} is HIGH and W_{FC} is LOW and W_{MEC} is LOW)

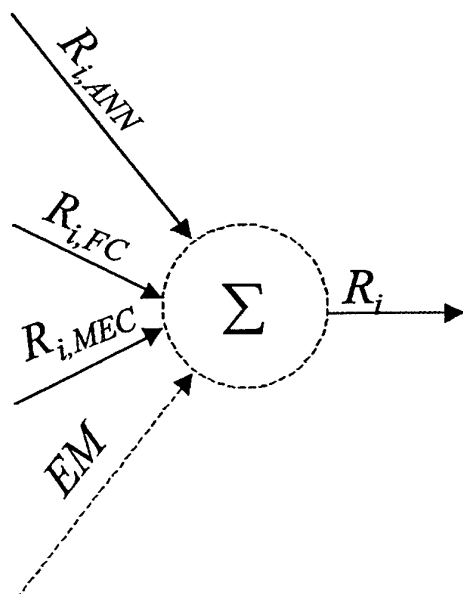

$$R_N = \frac{W_{ANN}R_{N,ANN} + W_{FC}R_{N,FC} + W_{MEC}R_{N,MEC}}{W_{ANN} + W_{FC} + W_{MEC}}$$

$$R_{PA} = \frac{W_{ANN}R_{PA,ANN} + W_{FC}R_{PA,FC} + W_{MEC}R_{PA,MEC}}{W_{ANN} + W_{FC} + W_{MEC}}$$

Control loop

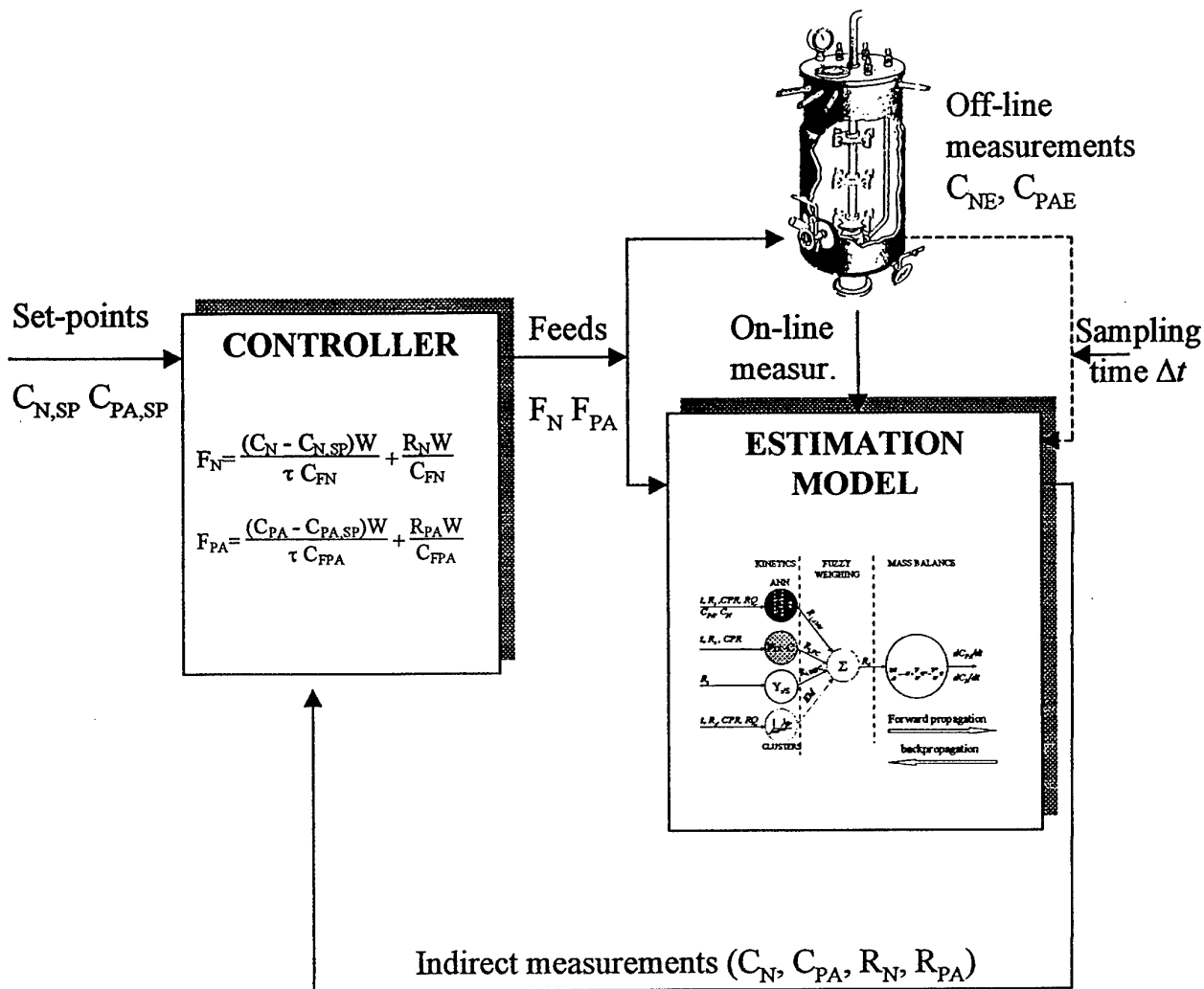

Results: Precursor automatic control 17 new runs in automatic

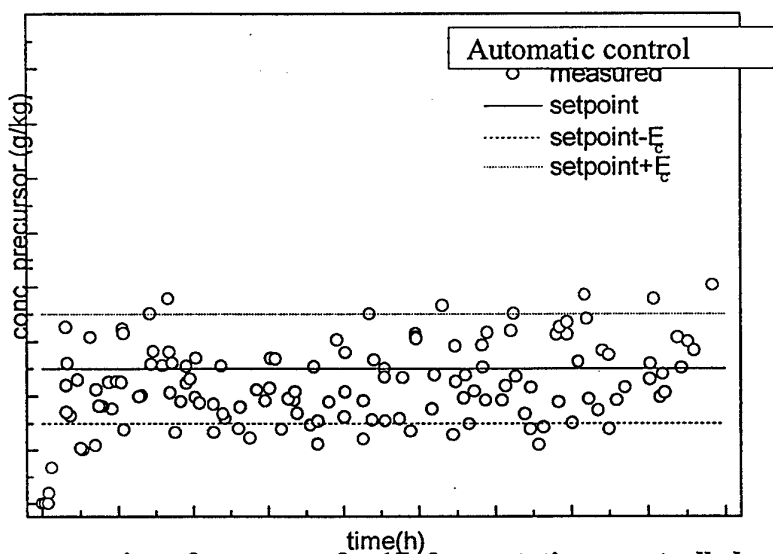

Fig. 1 - Concentration of precursor for 17 fermentations controlled automatically

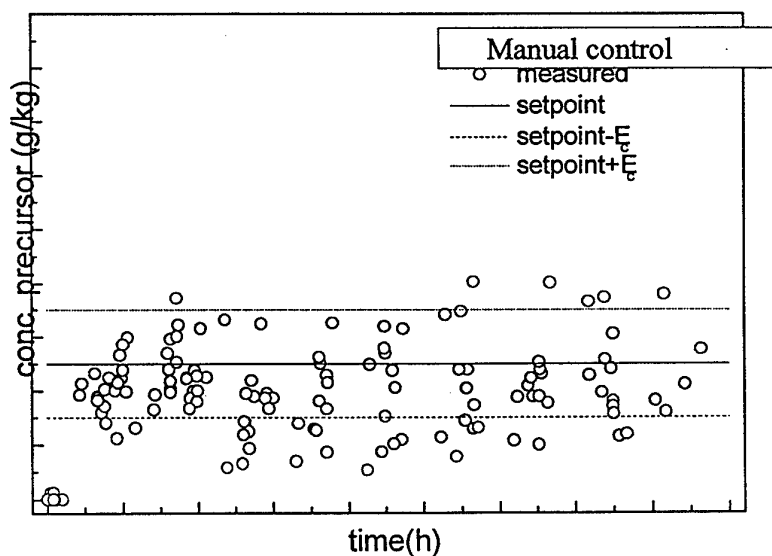

Fig. 2 - Concentration of precursor for 12 fermentations controlled manually (data used to develop the control system)

Results: ammonia automatic control 17 new runs in automatic

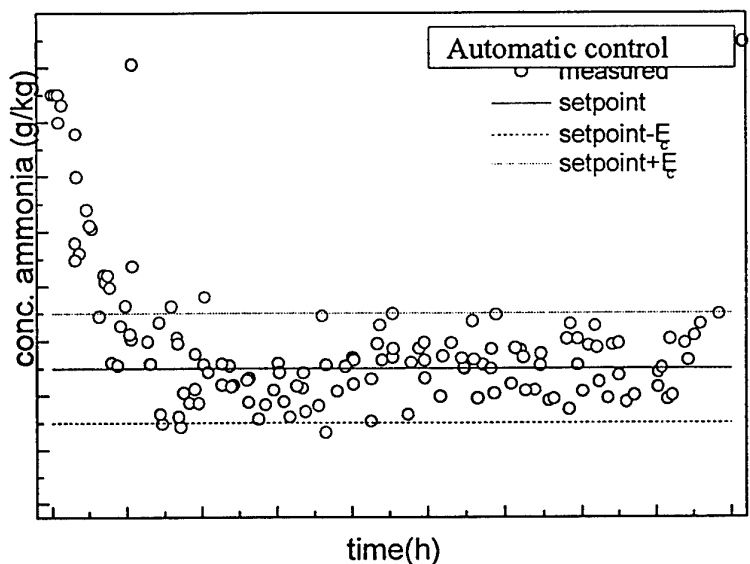

Fig. 3 - Concentration of ammonia for 17 fermentations controlled automatically

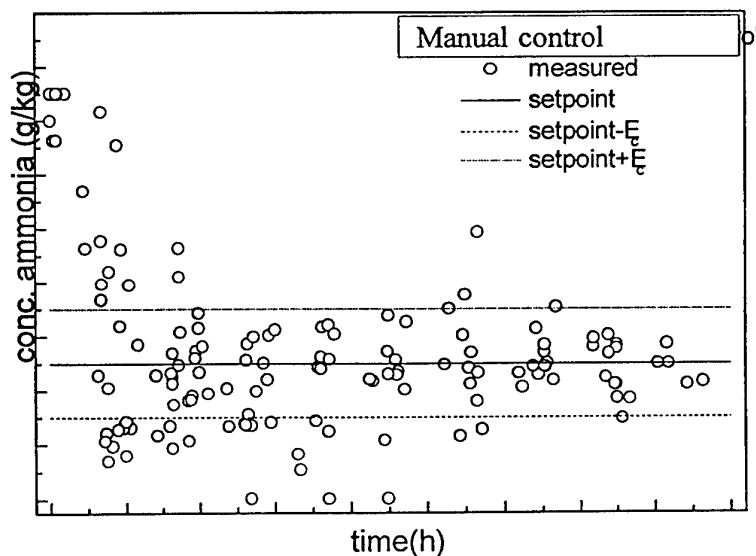

Fig. 4 - Concentration of ammonia for 12 fermentations controlled manually (data used to develop the control system)

Comments about results

- ✓ Deviations of ammonia concentration:
 - For automatic operation, the probability of concentration being outside the allowed operating range decreased 18% relatively to manual operation

- ✓ Deviations of precursor concentration:
 - For automatic operation, the probability of concentration being outside the allowed operating range decreased 22%

- ✓ On-line re-tuning of the hybrid method should be performed

Some concluding thoughts

- ☞ Today, the technological conditions are here, for bringing the theory into practice
- ☞ Model-based and adaptive methodologies and AI approaches will play a major role in process operation
- ☞ **The Human** factor as a limiting step in the pace of development
 - cost investment sometimes difficult to justify in the short-term
 - lack of human expertise and need of organizational changes in the Companies -
 - ☐ the pneumatic systems engineer of the 50's
 - ☐ the electronics engineer of the 70's,
 - ☐ the digital systems engineer of the 90's,

 - ☐ **the process systems engineer of the 00's**