

# AMPTIAC

NASA CONTRACTOR  
REPORT

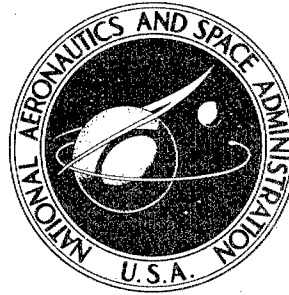

NASA CR-425

NASA CR-425

67320

Reproduced From  
Best Available Copy

## INVESTIGATION OF THE SONIC FATIGUE CHARACTERISTICS OF RANDOMLY EXCITED ALUMINUM VISCOELASTIC PANELS AT AMBIENT TEMPERATURES

*by B. J. Moskal*

Prepared under Contract No. NAS 1-4728 by  
NORTH AMERICAN AVIATION, INC.

Columbus, Ohio

*for Langley Research Center*

20000229 134

NATIONAL AERONAUTICS AND SPACE ADMINISTRATION • WASHINGTON, D. C. • APRIL 1966

**DISTRIBUTION STATEMENT A**  
Approved for Public Release  
Distribution Unlimited

NASA CR-425

INVESTIGATION OF THE SONIC FATIGUE CHARACTERISTICS  
OF RANDOMLY EXCITED ALUMINUM VISCOELASTIC PANELS  
AT AMBIENT TEMPERATURES

By B. J. Moskal

Distribution of this report is provided in the interest of information exchange. Responsibility for the contents resides in the author or organization that prepared it.

Prepared under Contract No. NAS 1-4728 by  
NORTH AMERICAN AVIATION, INC.  
Columbus, Ohio

for Langley Research Center

NATIONAL AERONAUTICS AND SPACE ADMINISTRATION

For sale by the Clearinghouse for Federal Scientific and Technical Information  
Springfield, Virginia 22151 - ~~503-603-6000~~

**DISTRIBUTION STATEMENT A**  
Approved for Public Release  
Distribution Unlimited

---

### ABSTRACT

An experimental sonic fatigue program was conducted on aluminum viscoelastic and aluminum control panels. The panels were tested at 154 db, 157 db, and 160 db using a Broad-Band Siren as the noise source. Previously, these structures were evaluated under discrete frequency excitation. The primary purpose of this effort was to continue to investigate the usefulness of viscoelastic structures under high acoustic random loads. Tests substantiate that the viscoelastic panel has slightly better sonic fatigue properties than an equivalent-by-weight aluminum panel.

INVESTIGATION OF THE SONIC FATIGUE CHARACTERISTICS OF  
RANDOMLY EXCITED ALUMINUM VISCOELASTIC PANELS  
AT AMBIENT TEMPERATURES

by

B. J. Moskal \*

SUMMARY

*Start*  
The relative effects of sonic fatigue on the structural integrity of aluminum viscoelastic and aluminum control panels were experimentally investigated at sound pressure levels of 154 db, 157 db, and 160 db. Three samples of the two types of panels were tested at each of the specified overall sound pressure levels.

Comparative data indicate that the viscoelastic panel has a longer sonic fatigue life than an equivalent-by-weight aluminum panel when subjected to a random acoustic environment. The average time-to-failure of the viscoelastic panel increased gradually as the acoustic input was decreased. The increase varied from approximately 1.6 times the average life of the aluminum panel at 160 db to 5.8 at 154 db. The root-mean-square stress measured 2.7 to 4.2 times less on the viscoelastic than on the aluminum panel at an equivalent sound pressure level and at the predominate response mode.

---

\* Columbus Division, North American Aviation, Inc.

Time-to-failure data recorded at a given sound pressure level on the three specimens showed very little scatter for the aluminum panel. The viscoelastic panel exhibited good correlation at 160 db, but at SPL's of 157 db and 154 db, the differences in failure time were more pronounced. The time-to-failure, on all the panels tested, ranged from 43 to 1666 minutes. Failures were characterized by minute cracks propagating along the downstream flange rivet line on the back side of the panel.

The general condition of bonding on the aluminum viscoelastic sheets was good with the exception of a few small unbonded areas near the edge of the sheet. Comparison of pre-test and post-test sonofax records of the constructed viscoelastic panels showed that no damage to the bond had developed during acoustic excitation.

## INTRODUCTION

This report describes the results of experimental research on aluminum viscoelastic and aluminum control panels. The present program is a continuation of part of the work reported in reference 1, "Investigation of the Fatigue Performance of Viscoelastic Panels at Elevated Temperatures", which was concerned with the sonic fatigue properties under single frequency acoustic excitation and at ambient, 200°F, and 300°F temperatures. In this experiment the interest lies in the response of the test specimens to a random acoustic environment at ambient temperature.

Prior to start of this work, a preliminary investigation was conducted to determine the proper choice of test sound pressure level and spectrum distribution. In addition, the stress response to a constant level random input was measured, the normalized correlation coefficient of sound pressure across a dummy panel was determined, and mode shapes and modal damping ratio were obtained. The results are reported in Appendix A.

The principal advantage of laminated structures over conventional metallic construction is its ability to combine the strength of existing structural materials with the damping ability of elastomers. It is important that new advances be in continual development in an effort to improve the performance of present day air vehicles. Structural integrity to the severe acoustic loadings is part of this development phase. Laminated structures are being applied throughout industry quite successfully in the solution of problems created by excessive mechanical vibratory disturbances. However, very little information has been compiled on the resistance to sonic fatigue. Viscoelastic

to p. 4

panels, with their built-in high damping characteristics, are very attractive to the aircraft designer as a secondary and perhaps a primary structure. Therefore, the present program is primarily concerned with the determination of the sonic fatigue properties under random acoustic loading and to compare these results with data obtained under discrete frequency excitation.

The work reported here was carried out in the Acoustic Laboratory of the Columbus Division, North American Aviation, Inc., between 8 January 1965 and 8 August 1965.

#### SYMBOLS

E	Young's modulus of elasticity, psi ( $10.5 \times 10^6$ psi for al.)
$E_o$	Output sensitivity of strain gage, volt/psi
F	Strain gage factor
$\bar{T}$	Average time-to-failure, minutes
V	Battery voltage, volts
X	Normalized signal displacement
f	Frequency, cps
t	Actual time-to-failure, minutes
x	Signal displacement
f(X)	Probability density
$\delta$	Damping ratio, $\frac{c}{c_c}$
$\sigma$	Signal root-mean-square displacement
$\sqrt{\bar{\sigma}^2}$	Root-mean-square stress, psi

#### SUBSCRIPTS

avg      Average

## ABBREVIATIONS

AL (al)	Aluminum
BW	Filter bandwidth, cps
min	Minutes
RMS (rms)	Root-mean-square
SLM	Sound level meter
SPL	Sound pressure level(s)

Note: Sound reference pressure =  $.0002 \text{ dyne/cm}^2$   
throughout this report

TC	Time constant, seconds
V-E (v-e)	Viscoelastic

## DEFINITIONS

Control panel - Test panel with aluminum web, aluminum stiffeners, and aluminum flanges.

Viscoelastic panel - Test panel with viscoelastic web, aluminum stiffeners and aluminum flanges.

## APPARATUS AND PROCEDURE

### Test Specimens

Nine aluminum viscoelastic and nine aluminum control panels were fabricated for this program. An additional four pilot panels, two of each type of construction, were used for a preliminary evaluation which included the measurement of stress response to a constant amplitude random input and the determination of an overall test level and spectral distribution that could produce panel failure within a reasonable length of time.

The <sup>Al</sup>viscoelastic test panels were constructed from .020 inch thick aluminum (2024-T3 ALCLAD) facing sheets and an .020 inch thick viscoelastic interlayer. The aluminum control panels were built from a .051 inch thick aluminum (2024-T3 ALCLAD) sheet. Two

aluminum stiffeners were riveted by round head rivets to both the viscoelastic and control sheets and thus resulted in a three bay construction. (The bays are designated as 1, 2 or center, and 3 as seen going away from the sound.) The center bay was 10 inches wide. The panel size was 24 x 24 inches. Four aluminum flanges, riveted to each panel, secured the test panel to a rigid structural frame by a series of aircraft steel bolts as shown in figure 1. The frame was fastened, top and bottom, to the test section wall of the broad-band siren by ten 3/4" diameter steel bolts. Five C-clamps attached to the upper side provided additional support.

The original panel design incorporated four braces located in the center bay area. The purpose of these braces was to strengthen the stiffeners and prevent stiffener failure. During the preliminary testing phase, stiffener failure was experienced prior to panel fatigue in the areas where the braces were not used. This type of failure obviously necessitated a modification to the panel. Three possible fixes were considered, namely: (1) adding aluminum braces to the other sides of the hat section stiffeners, (2) replacing the aluminum braces with steel braces, and (3) plugging the ends of the stiffeners with wood or metal plugs. The final fix included the addition of .051 inch aluminum braces and the insertion of wood plugs into the ends of the hat sections. With this modification, failure to the stiffeners did not occur. The wood plugs were made from hard maple, measured 2-1/2 inches in length, and weighed approximately 16 ounces. The total weight of each viscoelastic and control panel was  $9.5 \pm 0.3$  pounds. Figure 2 gives the modified panel configuration and shows the plug size, plug installation and brace attachment.

#### Sound Source

The sound was provided by a Broad-Band Siren which operates on the principle of modulating the airstream by a series of irregularly slotted rotors. This is accomplished by flowing air through a 3-inch converging nozzle and chopping it with four overlapping rotors which are irregularly slotted. The modulated airstream leaves the rotor chamber by another 3-inch nozzle directly coupled to a Hypex horn and terminated in a 4 x 1 x 14 foot test chamber. Four constant speed motors are used to drive the rotors. The rotors used for this experiment are numbered 6-9-3-8 and are shown schematically in figure 3. A detailed description of the siren and rotor configuration is reported in reference 2.

#### Instrumentation

The noise measuring instrumentation consisted of five condenser microphones and associated power supply systems, a sound level meter

and octave band analyzer. The location and designation of the microphones are indicated in figure 4. Prior to each day's test run, the microphones were checked at 500 cps with a calibrated portable acoustic source. Absolute calibration of each microphone was performed in an 18 x 18 x 18 foot anechoic chamber using the secondary free-field calibration technique.

Strain measurements were made by instrumenting each panel with a minimum of four or a maximum of six metalfilm strain gages, Type C12-1/1. The location and designation of the gages are shown in figure 5. Strain measurements were converted into stress data with the following expression

$$E_o = \frac{VF}{4E}$$

A block diagram representing the data acquisition and analysis system is shown in figure 6. The strain gage output was directed into a decade amplifier set at a gain of 100 and then into a magnetic tape recorder. The recorder was operated at 7-1/2 ips speed and in the AM mode. Microphone data were transmitted directly to the recorder.

In analyzing the stress and microphone signals, the taped data were made into continuous loops and channeled to a TP-625 Analyzer for a harmonic analysis and to a Probability Density Analyzer for probability density plots. During the course of investigation, the data were also reduced directly from the microphone or strain gage transducers. This procedure provided a continual study of the behavior of stress response and acoustical input.

The TP-625 Analyzer essentially consists of a bridge stabilized oscillator, an analyzer and a power integrator. The output from the power integrator is a d.c. analog which represented the RMS stress or the sound pressure levels as a function of frequency. The output from the integrator is connected to a logarithmic converter for ease in scale selection. The analysis was performed using an effective constant bandwidth filter of 14.2 cps and with a time constant of 0.5 second.

In review, the probability density function is mathematically defined as

$$f(x) = \frac{1}{\sqrt{2\pi} \sigma} e^{-\frac{x^2}{2\sigma^2}}$$

where  $f(x)$  is the probability density at a displacement  $x$  and  $\sigma$  is the rms displacement.

In the Probability Density Analyzer which was used in this program, the signal is normalized by equating  $\sigma = 1$  and then the machine equation becomes:

$$f(X) = \frac{1}{\sqrt{2\pi}} e^{-\frac{X^2}{2}}$$

The capital X is arbitrarily used to indicate that the input has been made to have a mean squared value of 1 volt.

### Inspection of Viscoelastic Sheets

All of the viscoelastic sheets were tested for unbonded and void areas using the Sonofax System. Three of the aluminum viscoelastic panels were inspected prior to testing and after the tests were concluded. A typical record of these results is shown in figure 7. Figure 7a shows several sonofax inspection records of viscoelastic sheets. (Note: The resolution of the sonofax records has been lost during re-photographic process).

The Sonofax System is a non-destructive inspection method which is capable of detecting unbonded and void areas and provides a permanent record of the location. This machine operates on a pulse-echo resonance principle using frequencies in the 10 to 15 megacycle range. Resonance occurs only when reflected ultrasonic waves add up in phase with the transmitted pulse. When voids or unbonded areas are present, the resonance condition will exist and maximum feedback signal will be observed. When unbonded or void areas are not present, the signal will be transmitted further into the laminate and will be absorbed rather than reflected. The signal level is monitored electrically and fed into an automatic indexing graphic recording system to produce a permanent record.

### TEST RESULTS AND DISCUSSION

A summary of the fatigue tests is given in Tables I and II. These tables include panel designation, sound pressure level, predominate response frequencies, root-mean-square stress amplitude at the various strain gage locations and the test time to failure. The test time to failure is defined as that time the crack was visually detected and does not refer to the time that an initial crack may have developed since this could not definitely be established in certain instances. The panels were visually inspected at least once every one-half hour at the start of the test and every 10 - 15 minutes preceding the time of anticipated failure. Table III describes the viscoelastic bond condition as observed from sonofax records.

## Sonic Fatigue Tests - Aluminum Control Panels

For the aluminum control panel, the three primary frequencies were 170 cps, 242 cps, and 308 cps at a test level of 154 db as seen at strain gage position #5. As the SPL was increased, the 170 cps mode, which was identified as the fundamental frequency of the center bay area from modal mapping, increased to 185 cps and 200 cps at SPL's of 157 db and 160 db, respectively. No significant changes were noted at the other two frequencies. However, a variation of  $\pm 10$  cps was noted from the above listed frequencies at the other strain gage locations. The primary response frequency and the point of maximum stress concentration was measured at 308 cps in bay area #3. This was the area where sonic fatigue failure occurred in all panels. Failures were characterized by minute cracks propagating along the downstream flange rivet line on the back side of the panel. The majority of the failures occurred approximately 1 - 2 inches above and/or below strain gage #5. Two of the control panels exhibited failures 6 inches above the stated reference position. The cracks would generally emanate from the rivet and progress in a downward or upward direction. Several cracks had developed 1/4" to 3/8" from the rivet center line as seen in figure 8.

It is interesting to note from Table I the absence of a high degree of scatter in the time-to-failure data. The exception was panel NAS-4C which failed after 570 minutes at 157 db. From previous experience with similar types of panel construction and from the data from this experiment, it was concluded that this data point was invalid and not considered in computing the average time-to-failure. Panel NAS-4C was instrumented with four strain gages located at positions 1, 2, 3 and 4--gage #5 was not installed. Comparison of these four strain gage measurements with readings from the other two panels tested at 157 db showed the stress amplitude to be approximately the same. Therefore, there was no reason to believe that the level at gage position #5 was different. Additional examination into the material properties and panel construction did not indicate any evidence upon which a conclusive statement could be made as to the reason for the long time-to-failure.

The average maximum RMS stress level and the average time-to-failure at the three test levels and at the principal mode (gage #5, 308 cps, 14.2 cps bandwidth) are listed below:

SPL db's	$\sqrt{\sigma^2}$ avg psi	$\bar{T}$ minutes
154	7030	151
157	7650	96.5
160	8500	48

Representative stress data and probability density plots for gage position 5 and 3 are reported in figures 9 and 10. Examples of response spectra at other gage locations in the center panel are similar to the response shown by gage #3.

The data in figure 9 show that the stress response of gage #5 has a strong component at 308 cps which is over 20 db higher in amplitude than at any other frequency point. In the probability density analysis this is evidenced by the dip in the probability curve. This curve indicates that, although the response may contain some degree of randomness, the resulting analysis is being greatly influenced by the non-random property of the stress response at the 308 cps frequency. An oscilloscope observation through a 50 cps window centered at 308 cps showed only a slight variation in signal amplitude with no apparent changes in phase.

Figure 10 is a graph representative of the frequency spectra and probability density of the stress response in the center bay area. The ratio of the amplitude of the fundamental mode to the other major frequency components is smaller than for the preceding case. A plot of the probability density of the unfiltered signal shows a greater degree of randomness as verified by its tendency to approach a normalized density. As the SPL was increased from 154 db to 160 db, the likeliness to the normal distribution had diminished and probability density function decreased from .37 at 154 db to .30 at 160 db at  $X = 0$ .

#### Sonic Fatigue Tests - Viscoelastic Panels

All of the viscoelastic sheets procured from the manufacturer were examined for unbonded and void areas with a sonofax machine. The general bond condition of these sheets was good with the exception of a small unbonded region near the edges on three of the specimens. Table III gives a description of the condition of the v-e sheets as observed from sonofax records.

Three assembled panels, designated as NAS-8V, -9V, and -10V, were subjected to pre-and post-test inspection. The post-test results showed that no damage had developed to the bond during acoustic excitation. Pre-test results indicated some unbonding occurred during the riveting operation. The amount depended upon the degree of panel dimple.

The results of the sonofax records on the bare v-e sheet, a pre-test panel and a post-test panel are illustrated in figure 7. In the post-test panel illustration, the vertical blank areas are indications of stiffener locations and do not represent void areas.

The v-e panel, with its higher damping characteristic than an equivalent-by-weight aluminum panel, experienced a longer fatigue life as a result of reduced stress amplitude at a given SPL. The average maximum RMS stress and average time-to-failure at the three test conditions at the principal mode (gage #5, 235 cps, 14.2 cps bandwidth) are listed below:

SPL db's	$\sqrt{\bar{\sigma}^2}$ avg psi	$\bar{T}$ minutes
154	1670	875
157	1870	341
160	3100	77

Comparing the above summarized data with that of the aluminum panels, it is seen that the fatigue life of the v-e panel is greater by a factor of 5.8 at 154 db, 3.5 at 157 db and 1.6 at 160 db. Stress data comparison indicates the RMS stress to be 4.2 times less at 154 db, 4.1 at 157 db and 2.7 at 160 db.

Detail examination of the time-to-failure data, Table II, indicates that a good correlation in fatigue time exists at 160 db; whereas, at 157 db and 154 db a noticeable degree of scatter is present. At 157 db, the fatigue time ranges from 155 minutes to 464 minutes and at 154 db from 463 to 1663 minutes. It is evident from figures 11 and 12, which are typical response curves at gage locations 5 and 3, that the time-to-failure variation is not being influenced greatly by the magnitude of the stress level. Therefore, it is suspected that the scatter in data is being introduced by manufacturing and panel construction methods.

The character of fatigue failure of the v-e panel is similar to that of the control panel. Failure occurred in bay area #3 and 1 - 2 inches above or below gage #5. A representative panel crack is displayed in figure 8.

The three primary response frequencies, as listed in Table II, are derived from analysis of gages #5 and #3 and they are: 160 cps, 235 cps and 300 cps at SPL's of 154 db; 165 cps, 235 cps and 305 cps at 157 db; and 165 cps, 235 cps and 300 cps at 160 db.

In figure 11, the amplitude of maximum stress occurs at 235 cps with another relatively strong component at the 300 cps mode. At 157 db and 160 db, a modal response was detected at approximately 270 cps. The amplitude of this stress was equal to or slightly less than at 160 cps. This point, however, was not inserted into Table II. The probability density plot, figure 11, of the unfiltered strain gage signal bears a close resemblance to a normal distribution. This

indicates, as evidenced by the harmonic analysis, that the signal contains some degree of randomness, and it is not being influenced by any periodicities that may be present.

The data in figure 12 are a good representation of the stress-frequency and probability density behavior in the center bay area. The center bay is primarily being driven at its fundamental mode (160 - 165 cps) with the higher modes being less responsive to the acoustic input.

### Noise Source Analysis

A harmonic analysis using a 14.2 cps effective bandwidth filter was conducted to determine the frequency content of the Broad-Band Siren at the three test levels of 154 db, 157 db, and 160 db. The data are reported in figure 13 at microphone locations 2 and 3. Microphone 3 was positioned at the center of the panel and microphone 2 near the center of bay area #3. The narrow-band analysis of these data shows that the noise source drops-off very drastically at 295 cps until it reaches a valley at 385 cps and then it gradually rises. This drop-off of the broad-band siren response in this region does not permit panel modes above approximately 335 cps to be excited strongly. However, from a preliminary modal analysis of the panel it is seen that only one of the four predominate modes is affected, the fourth mode. Within the region of the first three panel modes (160 - 300 cps) the amplitude of the noise source is maintained within a 5 db envelope, with the exception of two frequency points at 235 cps and 295 cps. The peak-to-valley ratio at 235 cps is approximately 10 db and at 295 cps as much as 14 db.

A probability density analysis of microphone 2 is also presented in figure 13 for an overall sound pressure level of 157 db and 160 db. This analysis typifies the results from all of the microphones used to monitor the noise. An octave band analysis is given in figure 14. Microphone analysis was conducted with the panels installed and with a 1/4 inch thick aluminum plate that was heavily damped with lead damping tape to determine the effects of panel radiation. No changes in frequency composition or amplitude were noted.

### Comparison of Discrete and Random Sonic Fatigue Data

Sonic fatigue data were obtained on a limited set of aluminum viscoelastic and aluminum control panels at discrete frequency, as reported in reference 1, and with random (broad-band) acoustic excitation. The comparison of these results is made in figure 15. Discrete frequency testing was conducted at sound pressure levels of 148 db, 154 db, and 160 db; broad-band testing was performed at an overall SPL of 154 db, 157 db and 160 db.

In figure 15, the average time-to-failure is plotted as a function of the overall sound pressure level. Comparing the data from the two types of excitation, it is shown that good correlation in fatigue time exists at a sound pressure level of 160 db. However, as the SPL is reduced, the time-to-failure relation has a tendency to diverge, with the fatigue time for discrete loading being shorter at a given sound pressure level. This scatter in fatigue life was also present between each similar type of sample tested at a given SPL, especially in the viscoelastic panels.

Fatigue life of viscoelastic and aluminum panels as a function of the average root-mean-square stress at the principal response mode for random loading is presented in figure 16. The principal frequency for the aluminum panel occurred at 308 cps and for the viscoelastic panel at 235 cps.

### CONCLUSIONS

Several broad conclusions may be made from the study of the fatigue properties on a number of samples of aluminum viscoelastic and aluminum control panels under random acoustic loading:

1. Comparative fatigue data indicated that the viscoelastic panel has a longer sonic fatigue life than an equivalent-by-weight aluminum panel by a factor 1.58 at 160 db, 3.5 at 157 db and 6.0 at 154 db.
2. Sonofax records of a pre-test and post-test panel indicate that acoustic excitation did not in any way weaken or produce an unbonded area. In some cases, riveting operation introduced a minute unbond area around the rivet head. This was especially noticeable in a panel that was highly dimpled. Sonofax records of all the viscoelastic sheets (prior to construction) showed the general condition of the bond to be good with exception of three sheets where a small unbond region was detected near the panel edge. An attempt was made to locate these areas in a position where fatigue failure was not anticipated.
3. The scatter in fatigue data was generally quite small. This was particularly true for the aluminum panels. Viscoelastic panels showed good correlation at 160 db; however, at 157 db and 154 db the degree of scatter was more pronounced. By averaging the time-to-failure data, it was possible to establish a reasonable pattern between the fatigue curves for the viscoelastic and control panels.

4. All of the fatigue failures occurred on the back side of the panel (away from the sound field) near the flange rivet line in bay area #3 (bay area #3 is downstream from the sound source). The cracks would generally emanate from the rivet and progress in a downward or upward direction. Several cracks had developed 1/4" to 3/8" from the rivet center line as seen in figure 8.

#### REFERENCES

1. Bennett, R.V.: Investigation of the Fatigue Performance of Viscoelastic Panels at Elevated Temperatures. NASA CR-162, February 1965
2. Moskal, B.J.: Investigation on the Spectral Shaping Capability of the Broad-Band Siren, Chapter 23, Acoustical Fatigue in Aerospace Structures, edited by W. J. Trapp and D. M. Forney, Jr. Syracuse University Press, 1965

## APPENDIX A

### PRELIMINARY TESTS AND ANALYSIS

The preliminary investigation included the measurement of stress response to a constant level random vibratory input, the determination of the overall test level and spectral distribution, the correlation of sound pressures across the test specimen, and the definition of mode shapes and modal damping ratio.

#### Vibration Tests

The purpose of the vibration tests was aimed to aid in the choice of the siren test spectra and also to determine the stress spectral response of the test articles to a pure random input.

One viscoelastic and one aluminum control panel were attached to a 24 x 24 x 2 inch aluminum plate and secured to the table of a 7500 lb. shaker as shown in figure 17. The plate was specifically designed for this examination and does not resemble the structural frame used in sonic fatigue tests. Initially, a 5 g constant amplitude sine input was applied and the response of both the v-e and aluminum panels was measured at one strain gage location. Following the sinusoidal excitation, a  $.5 g^2/cps$  random signal was applied to the panels. A frequency analysis up to 2000 cps from this test is shown in figure 18 for the v-e panel and in figure 19 for the control panel. The response of four strain gages (#1, #2, #3 and #4) was recorded; however the results from only gage #3 are reported here.

From figures 18 and 19, it is seen that both the control and v-e panels are responding strongly in the fundamental mode and at a frequency of 400 cps. Panel resonance between the aforementioned modes are also excited, however, to a lesser degree.

#### Siren Tests

The purpose of the siren tests was twofold: (1) to establish an overall test level in order to obtain fatigue failure in a reasonable length of time and (2) to obtain an acoustic spectral distribution that would produce a stress response most closely resembling the data received from vibration tests. The resulting rotor configuration employed rotors 6-9-3-8 (See figure 3) with an overall sound pressure level set at 154 db, 157 db and 160 db. Data from an internally sponsored research program provided the necessary information for the rotor choice (reference 2).

During this part of the study on panels designated as NAS-1C (control panel) and NAS-1V (v-e panel), fatigue failure to the stiffener braces was noted. Before proceeding with the second set of panels, four aluminum braces were added to the panel in hope of preventing stiffener failure.

After the establishment of the overall test levels, the second set of panels (which were primarily used to determine the time-to-failure) were tested at SPL's of 157 db and 160 db. The control panel (NAS-2C) failed after 5 hours and 55 minutes at 157 db. The failure was noted directly on the flange rivet center line in bay area #3. Since this seemed to be an unusual place for fatigue failure on these type panels, the test was continued. (This supposition was later verified during the test program in that a similar type of failure had not occurred.) After 10 hours and 42 minutes of test time, four stiffener braces failed and the test was stopped.

The second viscoelastic pilot panel (NAS-2V) was tested at 160 db. The reason for this procedure was that the overall RMS stress monitored on this panel was approximately equal to the stress on the control panel at 157 db. The NAS-2V failed after 5 hours and 44 minutes. Since no failure to the braces had occurred, it was decided to begin the main part of the experimental program without any additional changes.

Panel NAS-3C was subjected to SPL of 157 db. Brace failures occurred prior to panel failure. At this point it was decided to incorporate the wooden plugs into the panel design.

#### Correlation Study

For the purpose of correlating the sound pressures across the 24 x 24 inch test specimen, measurements were made at twenty-one positions on the surface of a dummy panel (correlation plate). The locations of the microphones are shown diagrammatically in figure 20. The panel is 1/4 inch thick 24 x 24 inch aluminum plate corresponding to the size of the test specimens. Microphones were flush mounted into the plate as shown in figure 21a. However, subsequent analysis showed that the same results can be obtained with the microphone arrangement given in figure 21b.

The normalized correlation coefficients are plotted in figure 22. These show the change in correlation with distance from the reference microphone, located at the center of the dummy panel. The analyses were made on the overall signal, that is, no filtering was used. The

overall correlation coefficient is typical of this type of siren. The vertical survey yields a symmetrical curve which tends to follow a cosine function up to approximately 6 inches away from the reference point and then it tends to slightly sweep up. The horizontal survey also produces a symmetrical curve whose correlation coefficient varies from +1.0 at the reference point to +.81 at 10 inches on the up side and +.78 at 10 inches on the down side.

#### Modal Damping and Mode Mapping

Mode shape information and damping ratio for both the soft and hard suspension systems was presented in reference 1. Since failure to panel stiffeners made it necessary to modify the original panel design by the addition of braces and the insertion of wooden plugs into the stiffener ends, a brief examination of these two parameters was made in this program. The mode shapes, using the soft suspension system are presented in figure 23 for the viscoelastic and aluminum panels. Figure 24 gives the damping ratio as determined while the panels were installed in the test fixture.

At the low frequency, the damping ratio of the v-e and aluminum panels is approximately the same; however, as the frequency is increased, the v-e panel shows a gradual increase over the aluminum panel.

TABLE I: STRESS SUMMARY ON ALUMINUM CONTROL PANELS AT PREDOMINATE RESPONSE FREQUENCIES

PANEL DESIGNATION	SPL db's	f cps	RMS STRESS AMPLITUDE, $\sqrt{\sigma^2}$ , PSI							t minutes
			GAGE #1	#2	#3	#4	#5	#6	#7	
NAS-12C	154	170	2000	2400		260	400	150	92 min.	
		240	725	440		300	100	270		
		310	1300	1100		6800	2000	2800		
NAS-11C	154	170	1800	2200		360	500	250	164 min.	
		242	500	560		500	130	310		
		308	640	860		7500	2200	2000		
NAS-10C	154	170	1100	2350		250	400	200	198 min.	
		242	400	550		400	95	390		
		308	900	750		6800	1600	3000		
NAS-8C	157	185	1500	1800	1700	340	400	400	101 min.	
		240	550	700	600	480	320	320		
		300	600	550	400	7000	1550	1550		
NAS-6C	157	185	2000	2000	2000	290			92 min.	
		240	700	800	650	400				
		300	500	590	400	8300				
NAS-4C	157	185	1100	1700	1700				570 min.	
		240	300	440	350					
		300	400	500	400					
NAS-9C	160	200	2400	2500		600	900	560	53 min.	
		240	1300	1200		950	460	800		
		295	650	650		8500	2500	2150		
NAS-7C	160	200	1600	2200	2400	540	600	600	48 min.	
		240	680	850	900	1100	320	320		
		295	600	500	480	8500	1800	1800		
NAS-5C	160		NO DATA					43 min.		

TABLE II: STRESS SUMMARY ON VISCOELASTIC PANELS AT PREDOMINATE RESPONSE FREQUENCIES

PANEL DESIGNATION	SPL db's	f cps	RMS STRESS AMPLITUDE, $\sqrt{\sigma^2}$ , PSI							t minutes
			GAGE #1	#2	#3	#4	#5	#6	#7	
NAS-11V	154	160	650	1050		200	115	200	200	463 min.
		235	320	440		1700	300	1150	1150	
		300	180	180		1100	115	540	540	
NAS-10V	154	160	400	970		460	95	300	300	1663 min.
		235	360	500		1700	125	1100	1100	
		300	80	180		960	150	250	250	
NAS-9V	154	160	650	840		400	75	300	300	508 min.
		235	360	480		1600	150	1300	1300	
		300	190	200		1150	120	230	230	
NAS-7V	157	165	1050	1550		250	500	150	150	404 min.
		235	110	440		2150	590	1000	1000	
		305	400	370		1130	170	390	390	
NAS-5V	157	165	950	1900	1650	500				155 min.
		235	120	700	300	1950				
		305	360	250	160	930				
NAS-3V	157	165	830	2150	800	400				464 min.
		235	380	600	380	1500				
		305	120	180	70	750				
NAS-8V	160	165	1900	1950		600	580	400	400	72 min.
		235	340	650		2900	540	2100	2100	
		300	340	370		1250	175	360	360	
NAS-6V	160	165	1800	1650	1350	740	750			90 min.
		235	320	540	240	3400	600			
		300	260	320	150	1300	200			
NAS-4V	160	165	1950	1950	2200	850				69 min.
		235	400	600	540	3000				
		300	250	260	240	1100				

TABLE III: SUMMARY OF VISCOELASTIC PANEL BOND CONDITION  
AS OBSERVED FROM SONOFAX RECORDS

PANEL DESIGNATION	SPL db's	t min.	REMARKS
NAS-9V	154	508	Bonding very good over the entire panel except along one edge. The unbonded surface measured 24 inches in length and approximately 1-1/4 inches in width. During sonic fatigue test this defective area was located upstream with respect to the sound source. Failure to this panel occurred, as to all panels, along the flange rivet line in bay area #3, the downstream side. Post-test Sonofax examination revealed no additional unbonding during the test period (see figure 7).
NAS-10V	154	1663	Bond condition very good, very slight ripple in aluminum skin. No changes in panel condition with post-test Sonofax examination.
NAS-11V	154	508	Bond and panel condition very good.
NAS-3V	157	464	Slight ripple over entire aluminum sheet. General bond condition was good. Unbonded area 12 inches in length and 1/4 inch wide was noticed along one edge.
NAS-5V	157	155	Bond condition good.
NAS-7V	157	404	No unbonded conditions detected. A weak bond was noticed in the center of the panel and from one corner to the center of the panel.
NAS-4V	160	69	Bond condition good. Intermittent unbonding was observed along the edges on two sides of the panel, approximately 1/4 inch wide.
NAS-6V	160	90	Bond panel condition very good.
NAS-8V	160	72	Bond panel condition very good. No changes in panel condition with post-test Sonofax examination.

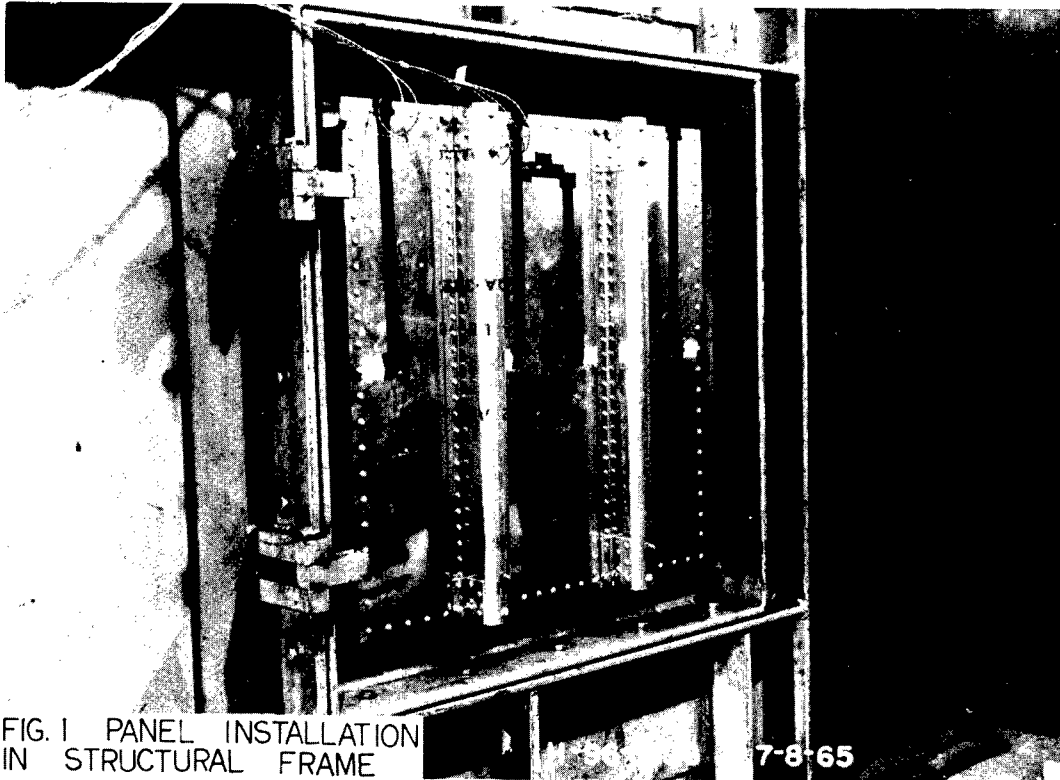

FIG. 1 PANEL INSTALLATION  
IN STRUCTURAL FRAME

H-96-589B 7-8-65

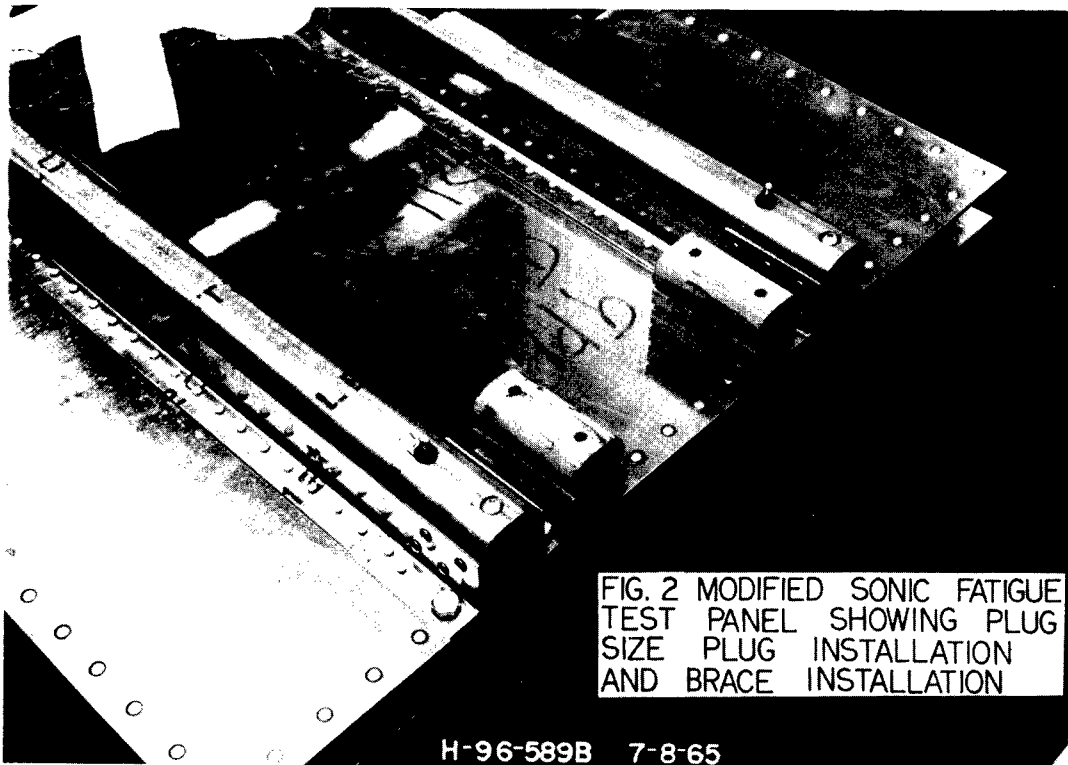
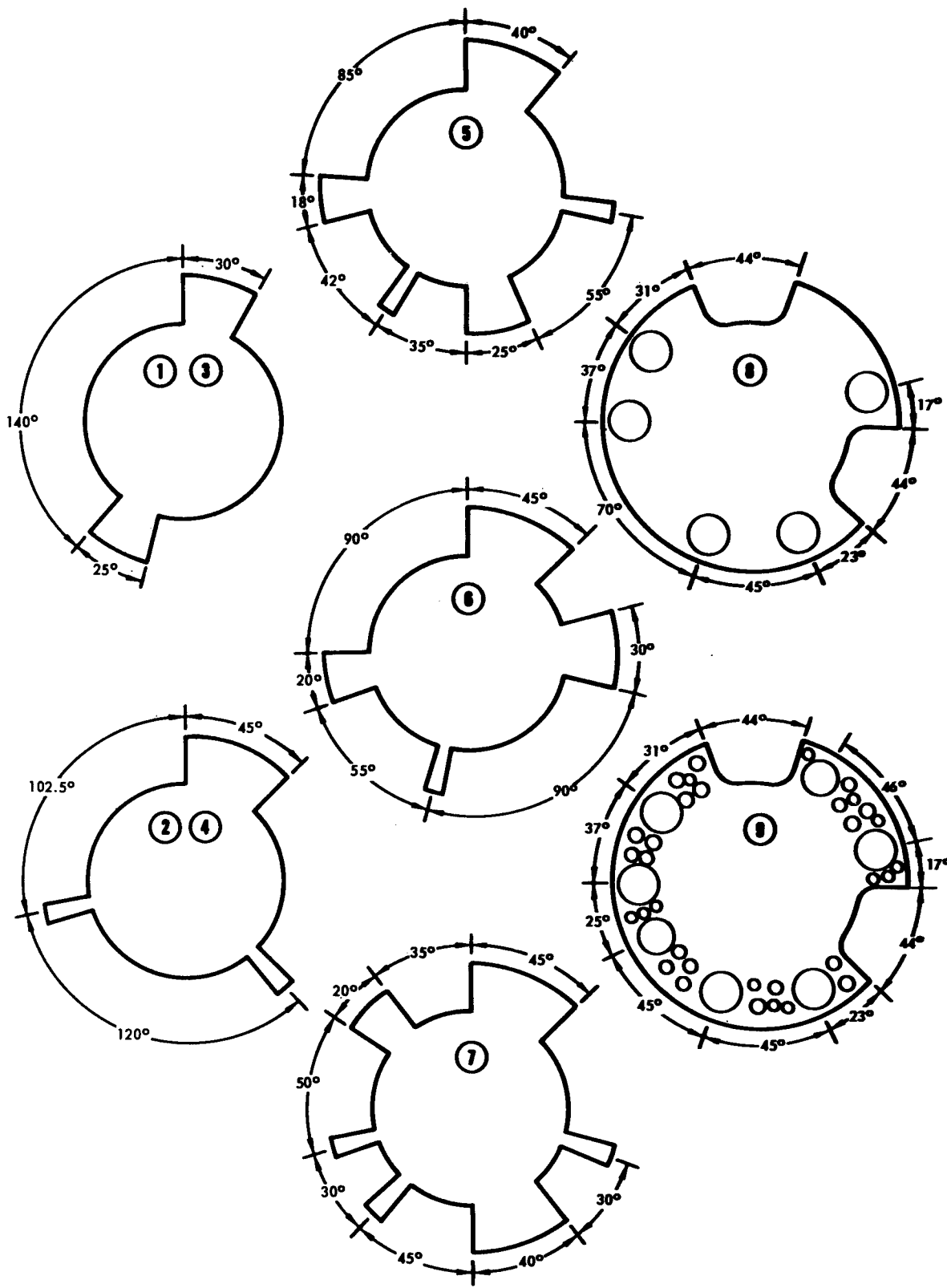

FIG. 2 MODIFIED SONIC FATIGUE  
TEST PANEL SHOWING PLUG  
SIZE PLUG INSTALLATION  
AND BRACE INSTALLATION

H-96-589B 7-8-65



**FIG. 3 ROTOR SHAPES**

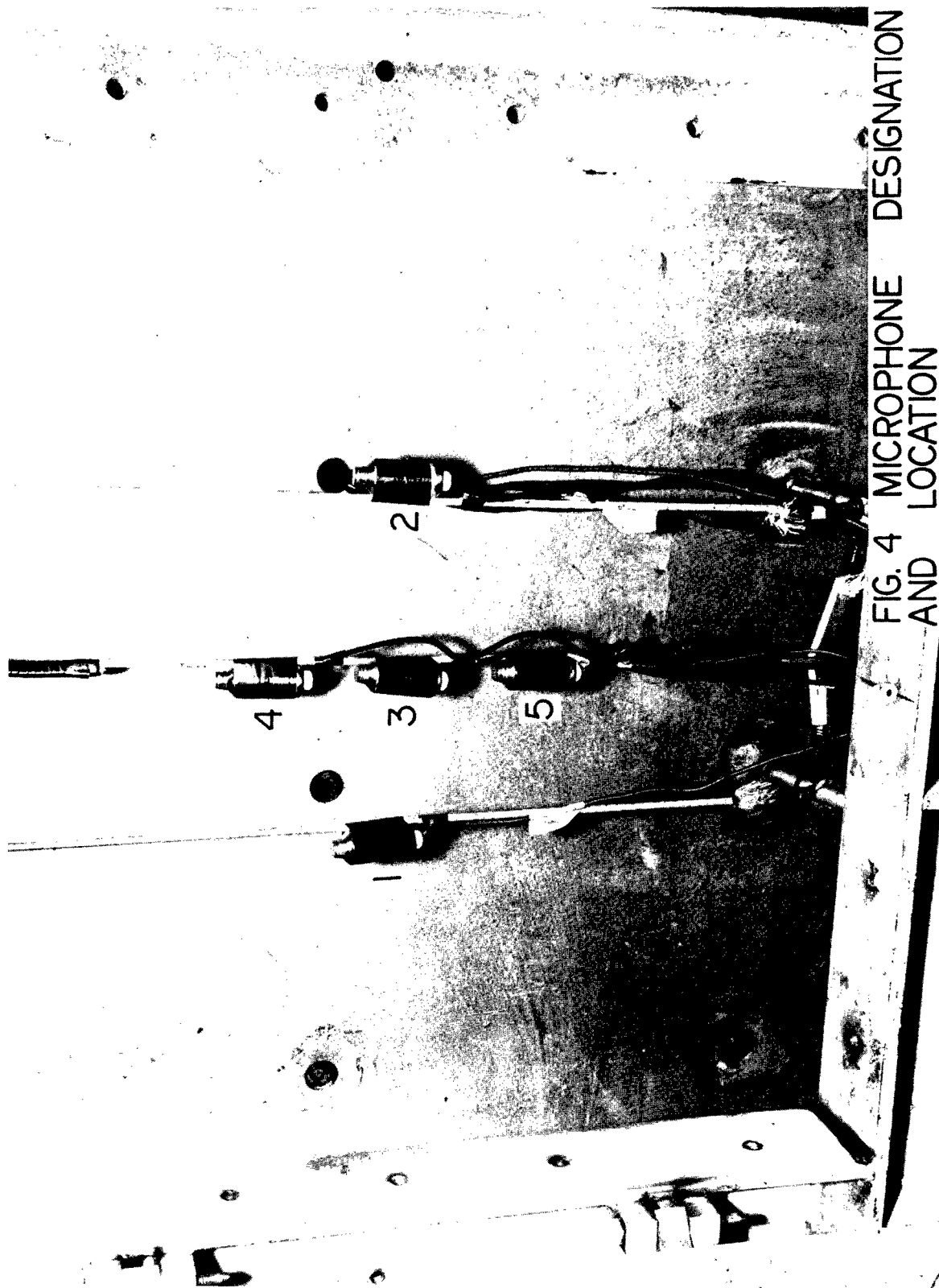

FIG. 4 MICROPHONE DESIGNATION AND LOCATION

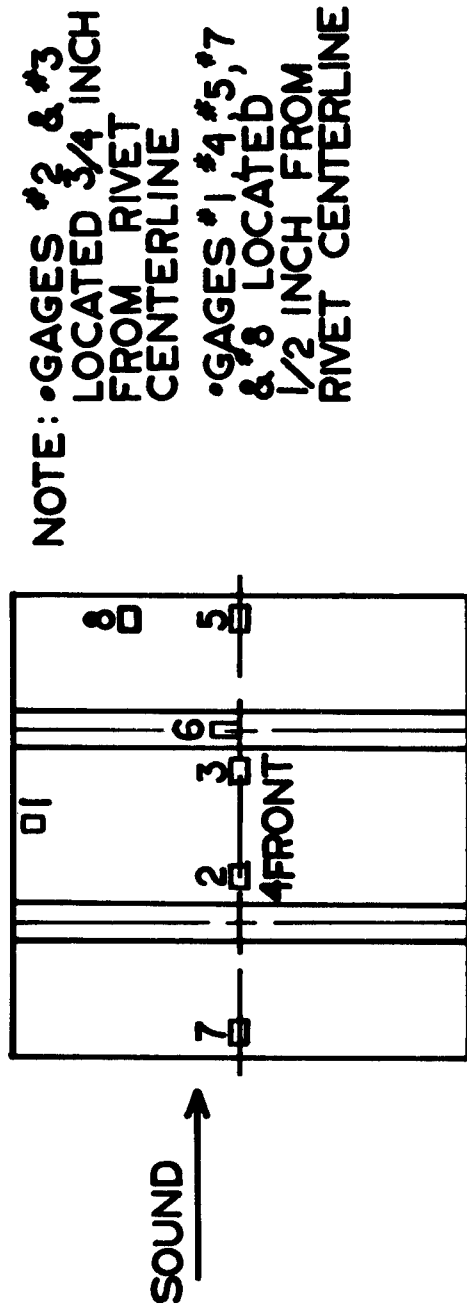

FIG. 5 STRAIN GAGE LOCATION AND DESIGNATION  
BACK SIDE OF PANEL

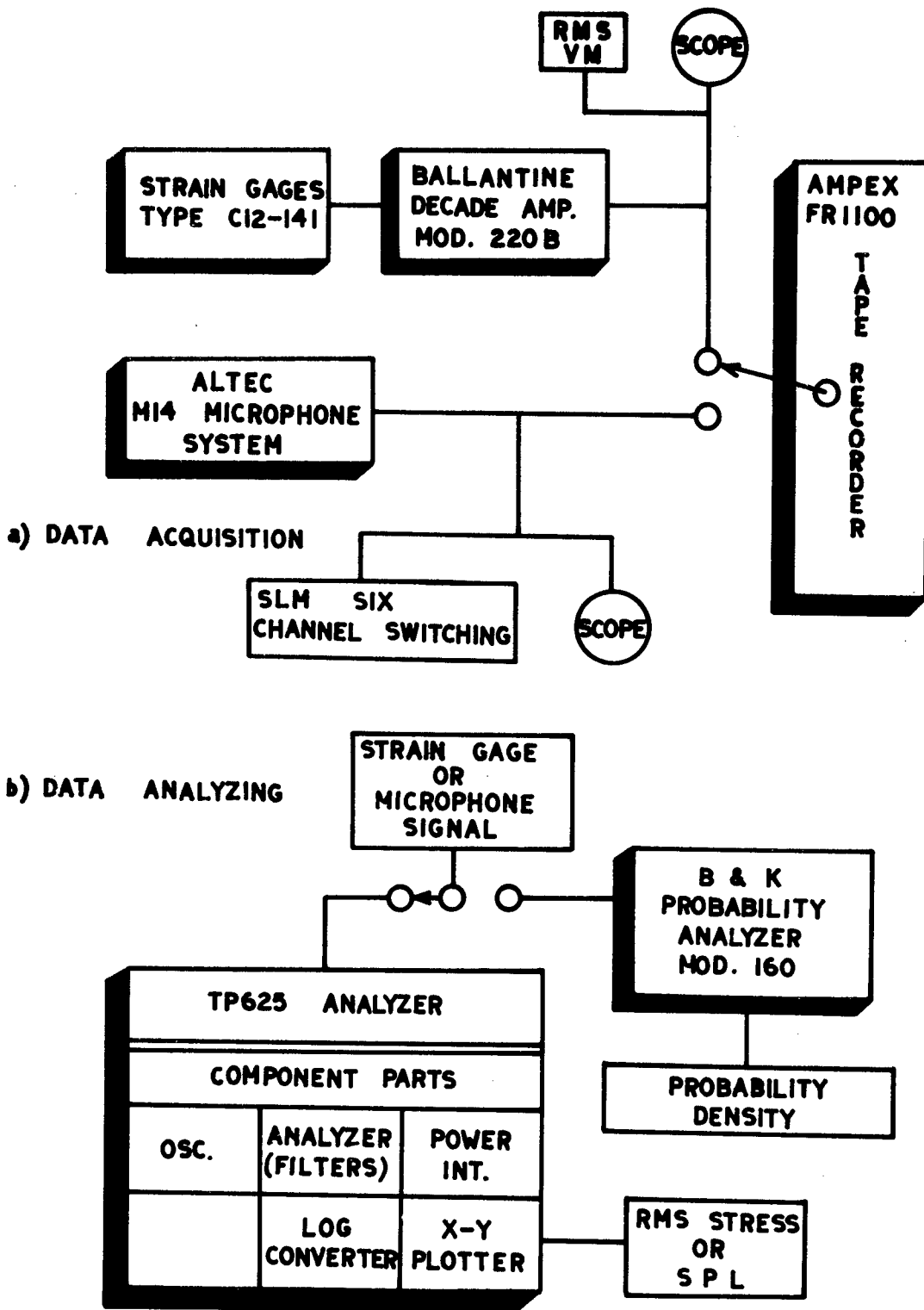
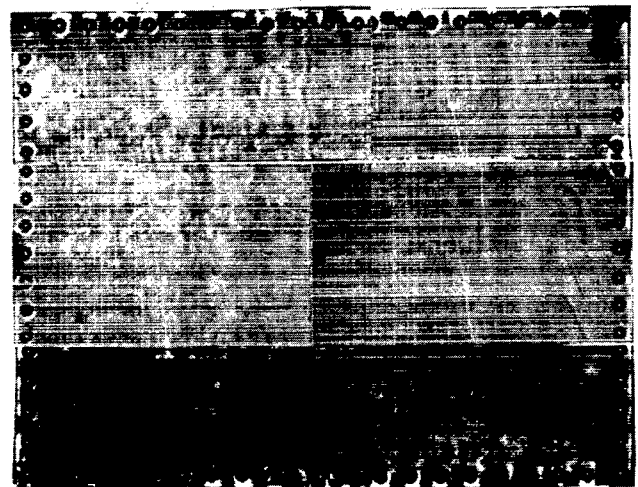
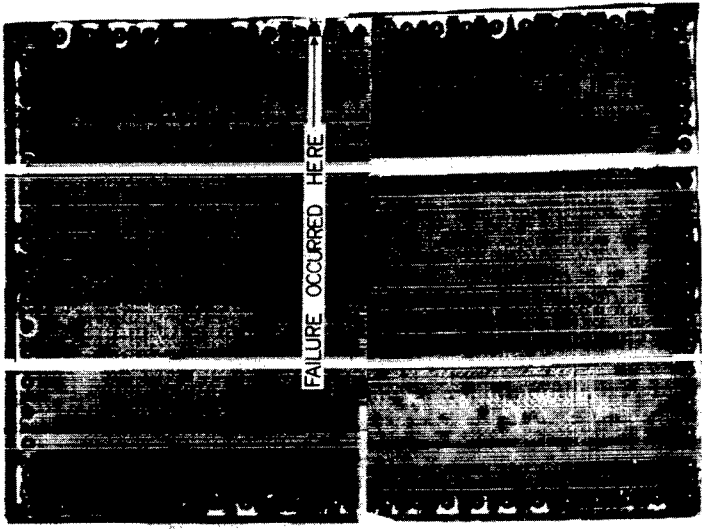

FIG. 6 BLOCK DIAGRAM OF DATA PROCESSING SYSTEM



V-E SHEET

PANEL ASS'Y - PRE TEST

PANEL ASS'Y - POST TEST

FIG. 7 TYPICAL SONOFAX RECORDS OF VISCOELASTIC PANEL

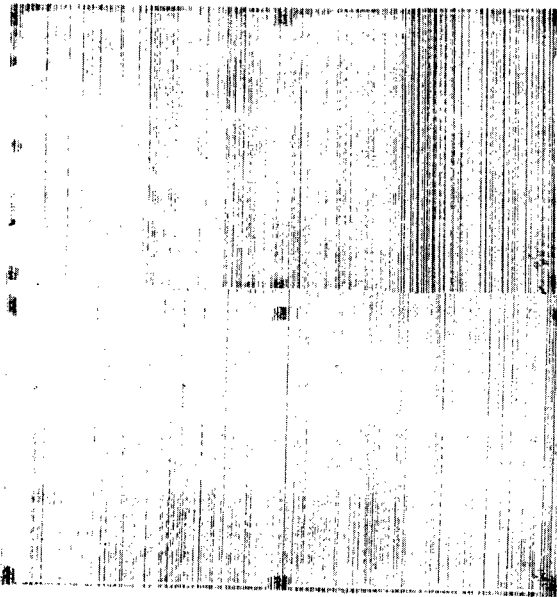

BOND VOID NEAR EDGE

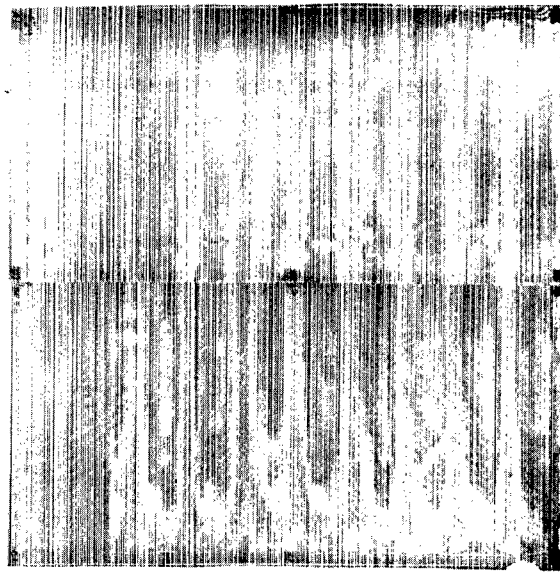

SLIGHTLY RIPPLED AL. SHEET

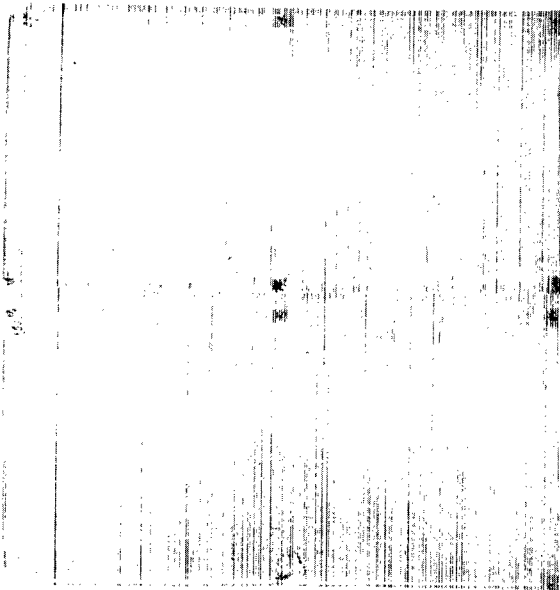

GOOD BOND

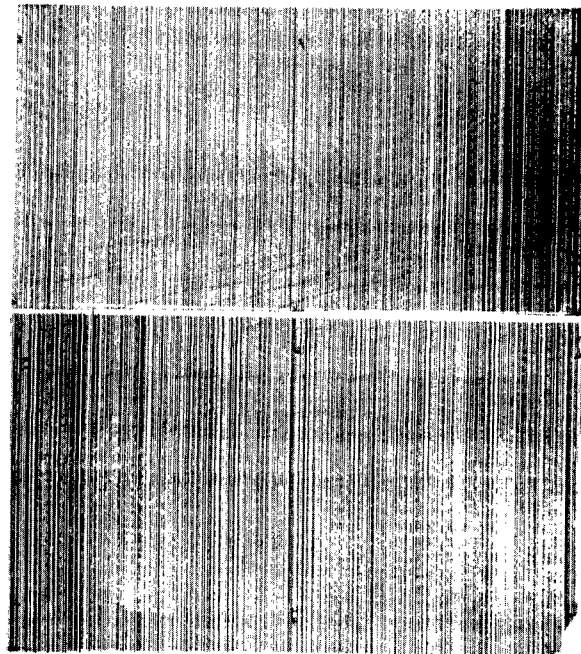

GOOD BOND

FIG. 7a: SONOFAX RECORDS OF VISCOELASTIC SHEETS

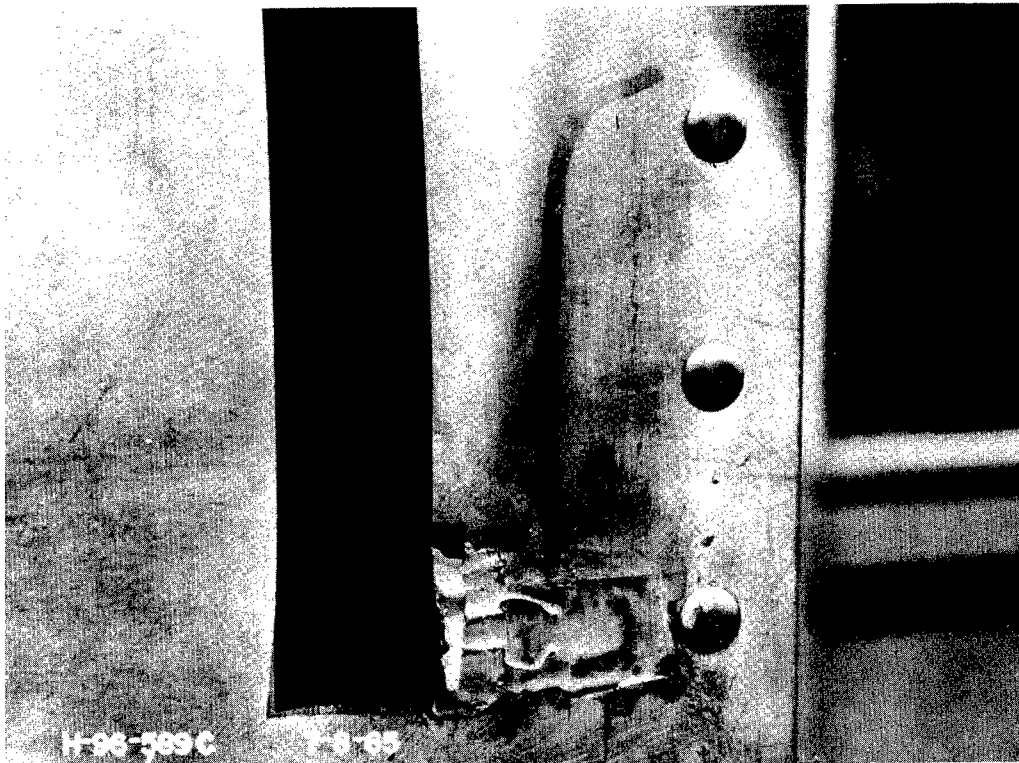

H-90-589C

7-8-65

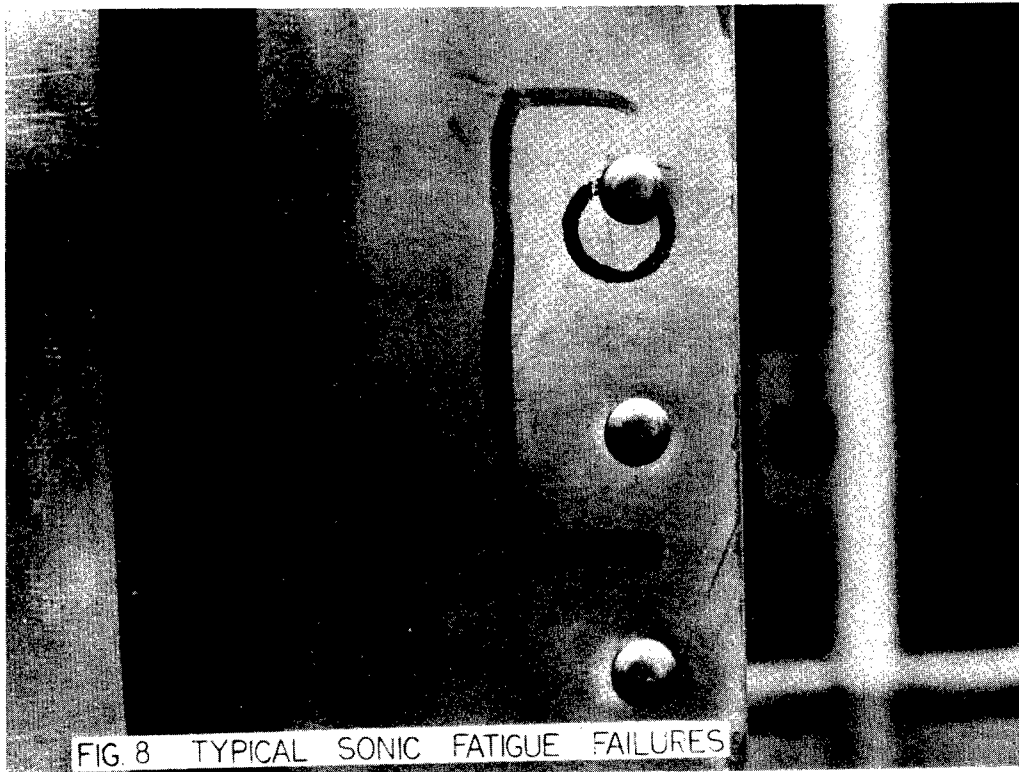

FIG. 8 TYPICAL SONIC FATIGUE FAILURES

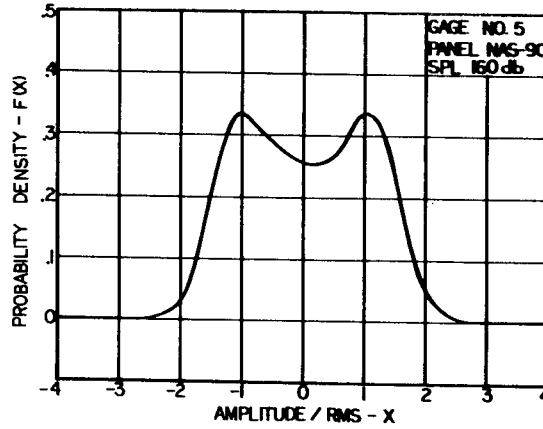
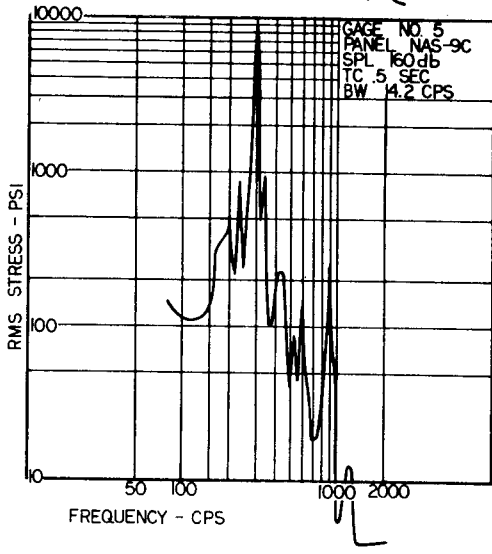
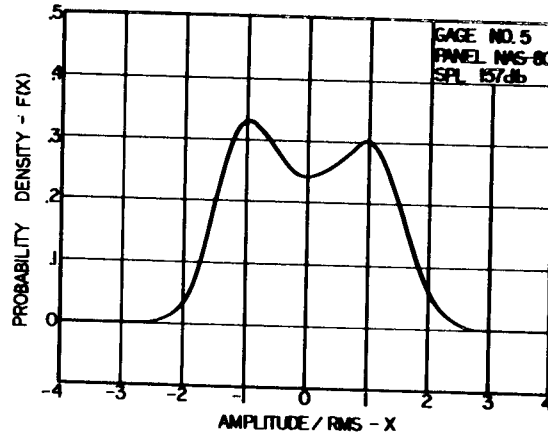
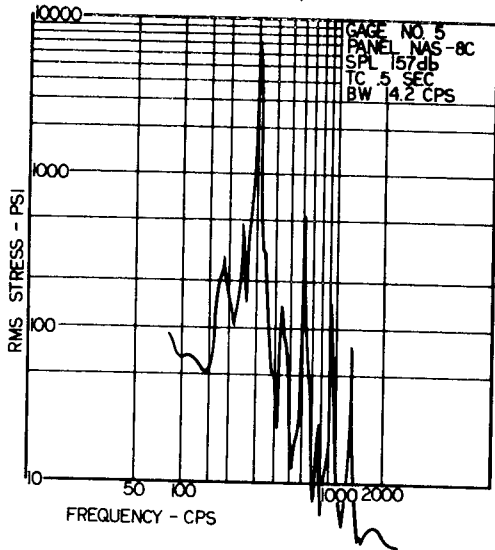
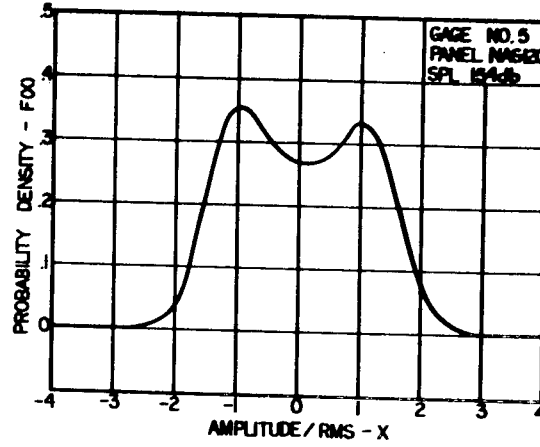
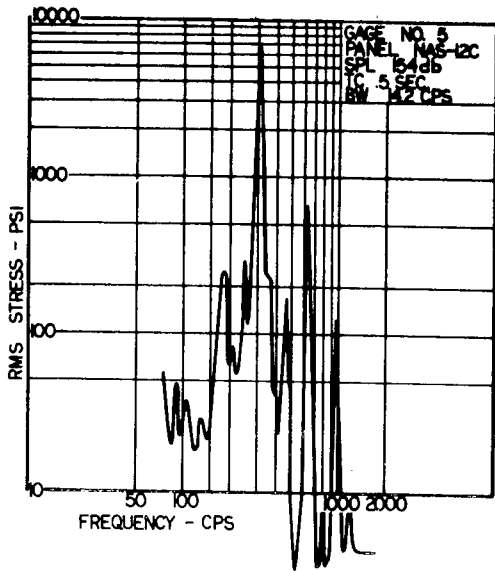

FIG.9 TYPICAL RMS STRESS RESPONSE AS A FUNCTION OF FREQUENCY AND PROBABILITY DENSITY ANALYSIS FOR ALL CONTROL PANEL AT THE 3 TEST SPL

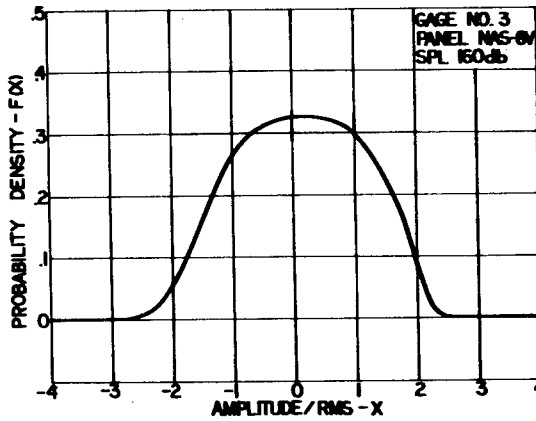
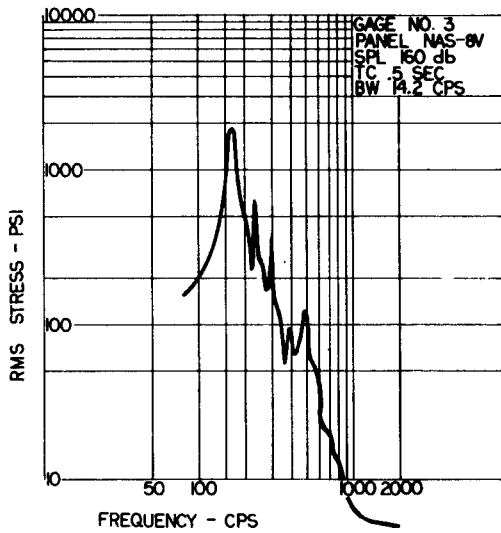
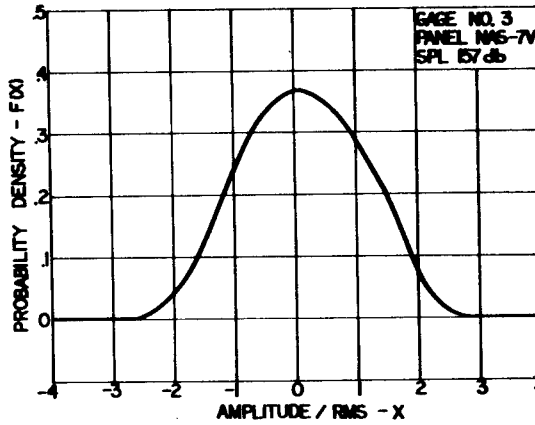
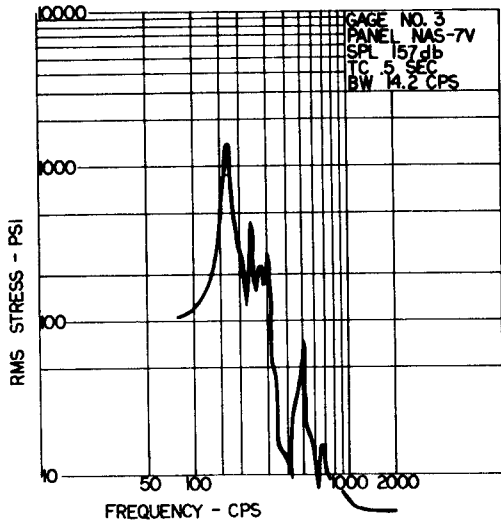
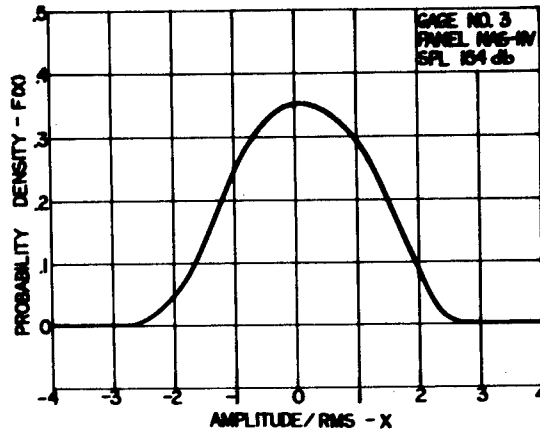
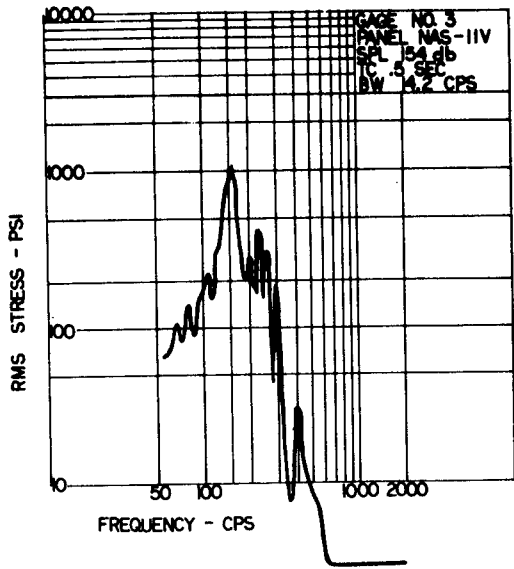

FIG. 10 TYPICAL RMS STRESS RESPONSE AS A FUNCTION OF FREQUENCY AND PROBABILITY DENSITY ANALYSIS FOR AL CONTROL PANEL AT THE 3 SPL

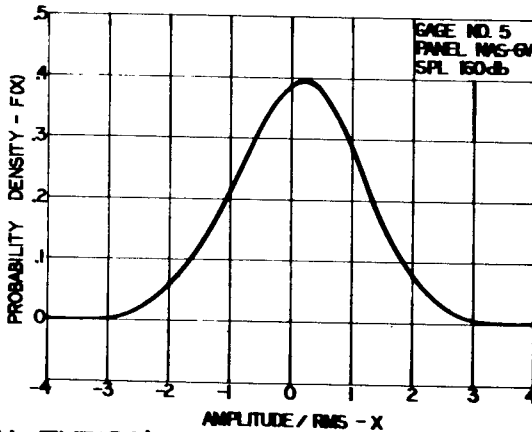
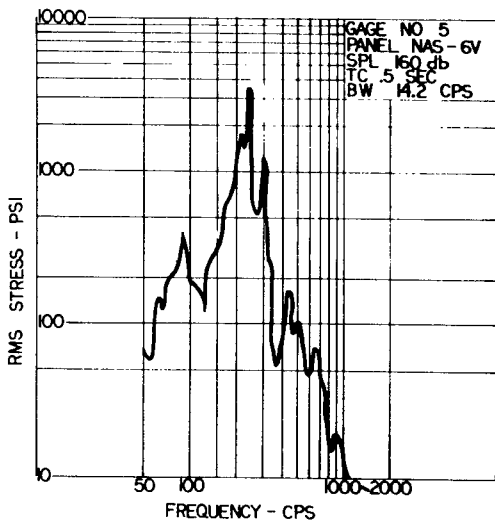
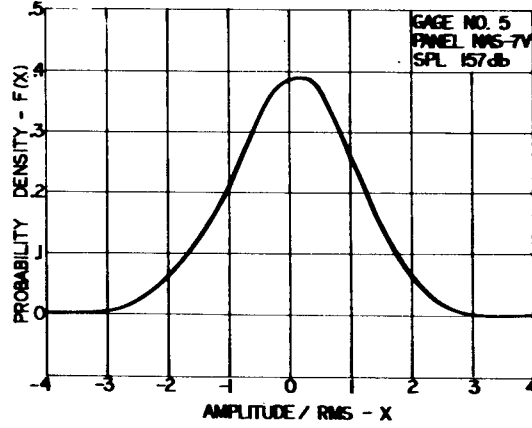
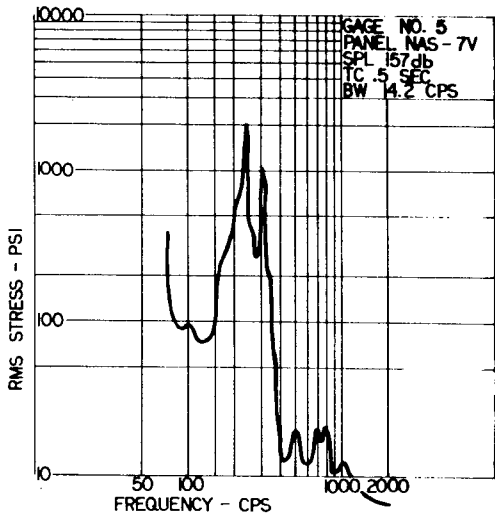
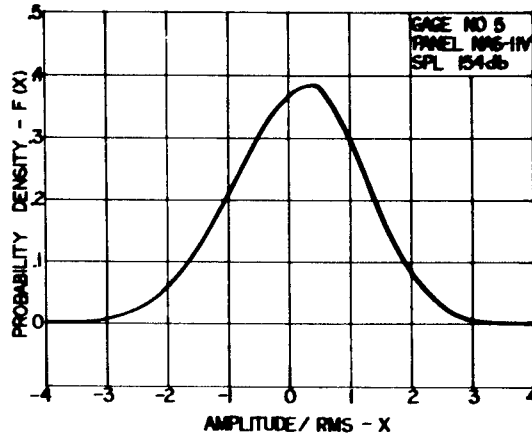
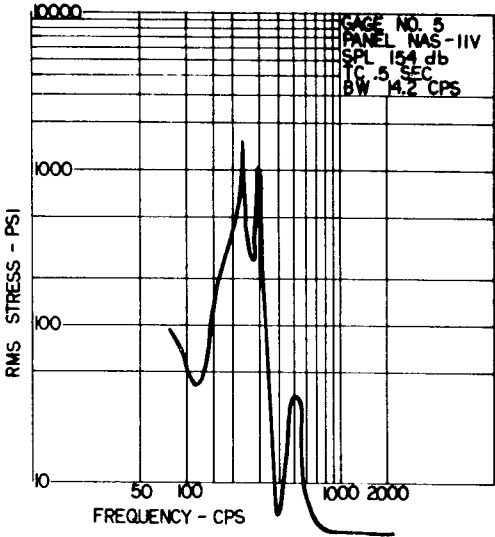

FIG. II TYPICAL RMS STRESS RESPONSE AS A FUNCTION OF FREQUENCY AND PROBABILITY DENSITY ANALYSIS FOR V-E PANEL AT THE 3 SPL

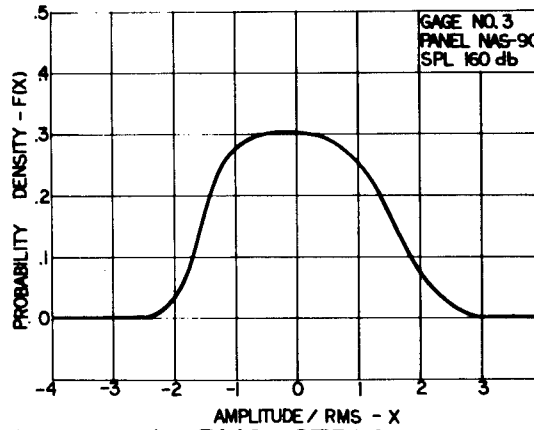
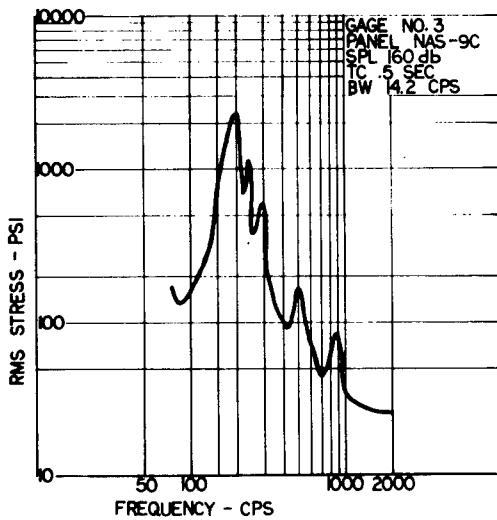
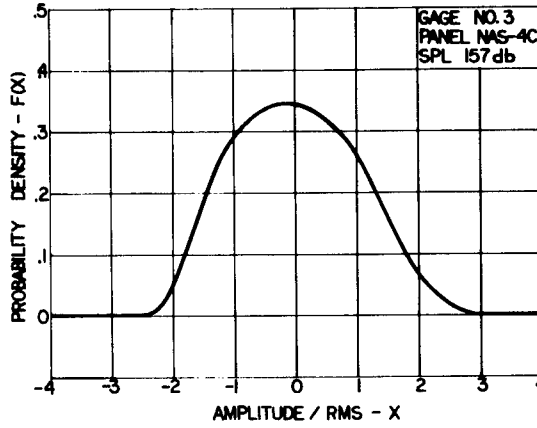
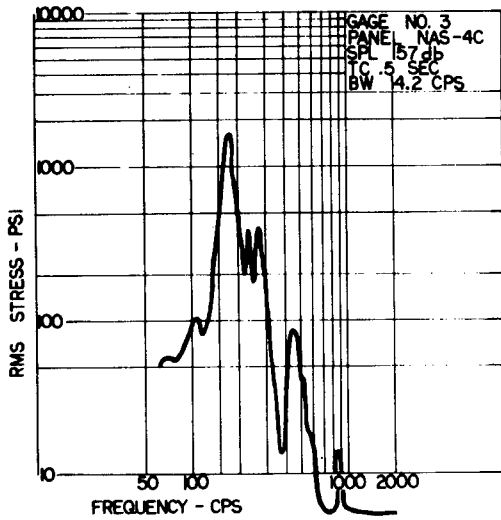
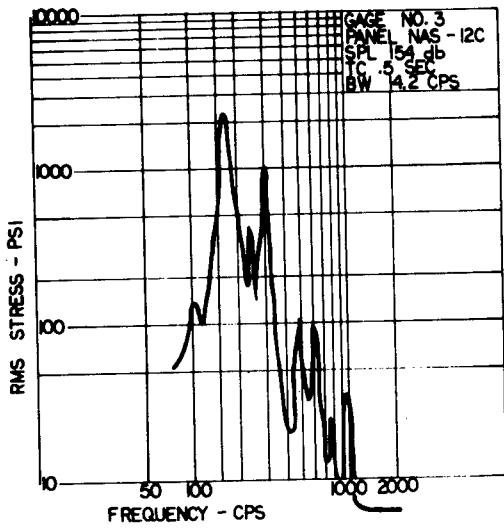

FIG. 12 TYPICAL RMS STRESS RESPONSE AS A FUNCTION OF FREQUENCY AND PROBABILITY DENSITY ANALYSIS FOR V-E PANEL AT THE 3 SPL

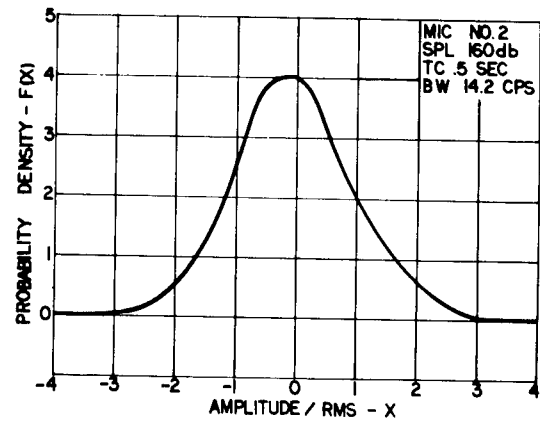
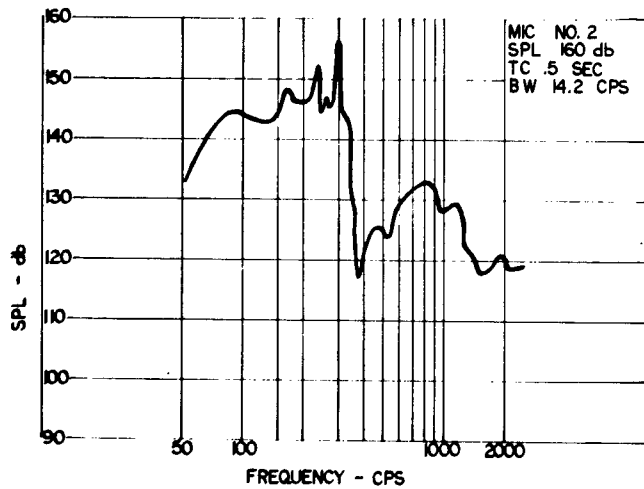
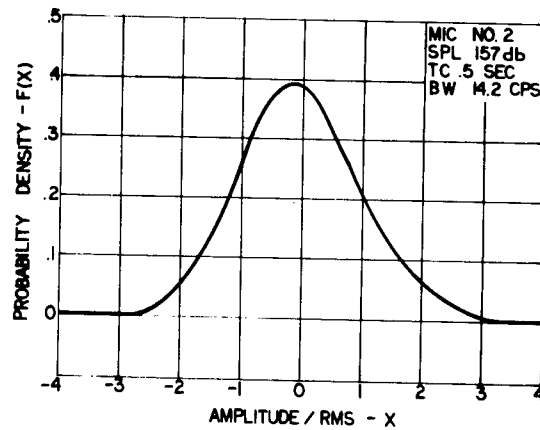
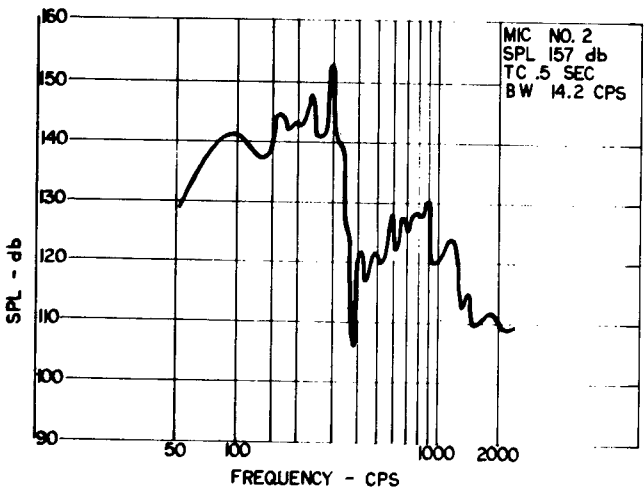
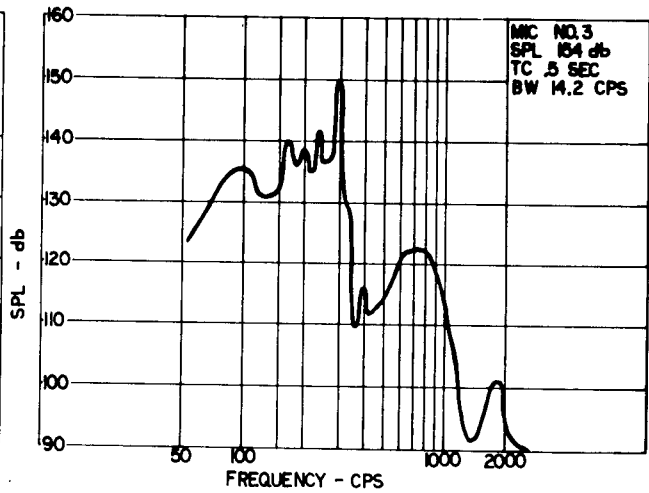
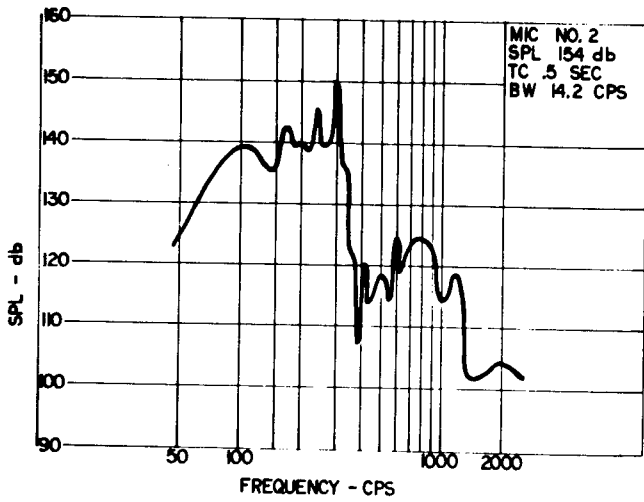

FIG. 13 NARROW BAND AND PROBABILITY DENSITY ANALYSIS OF THE NOISE SOURCE (BROAD BAND SIREN)

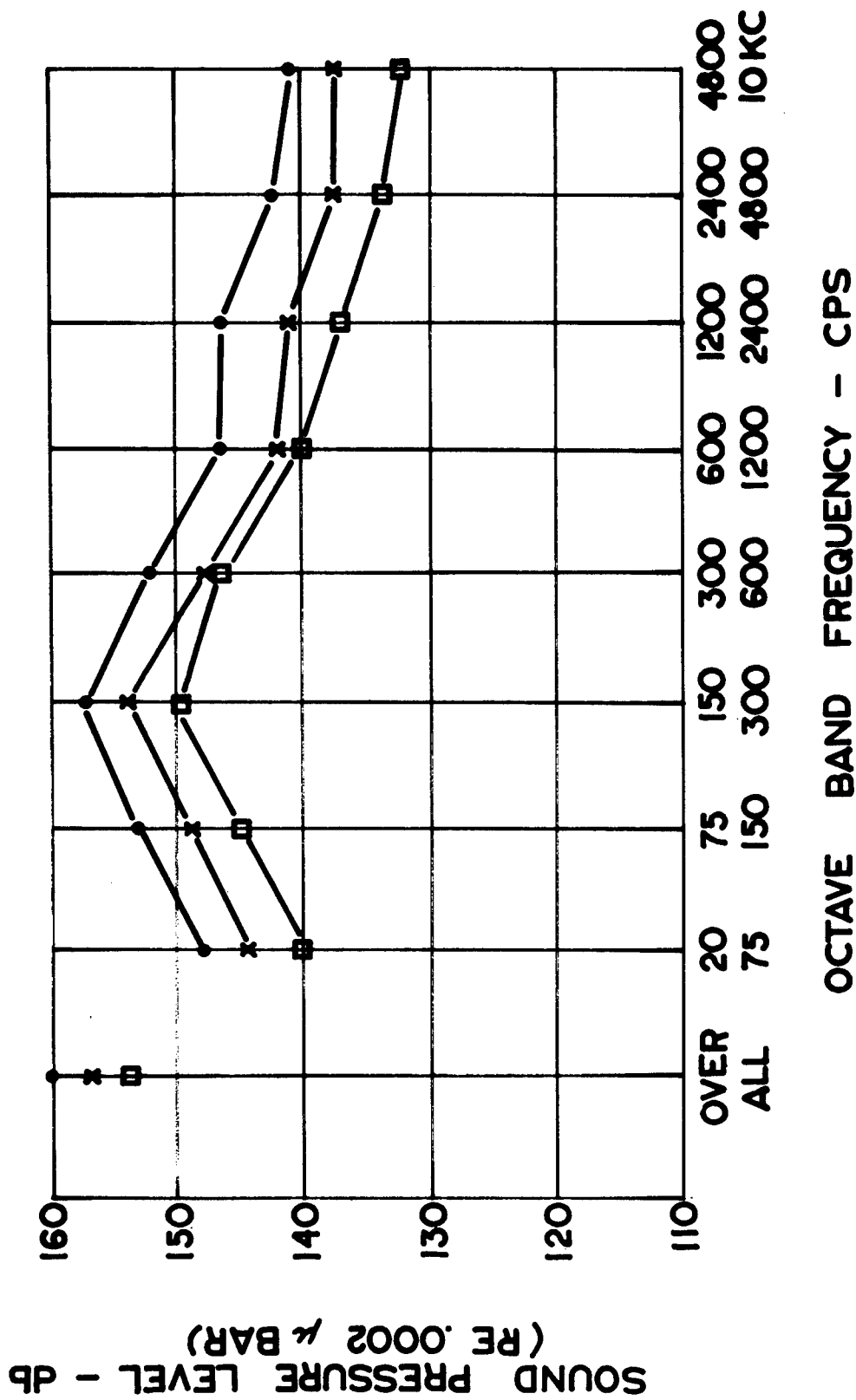

FIG. 14 OCTAVE BAND ANALYSIS OF TEST LEVELS

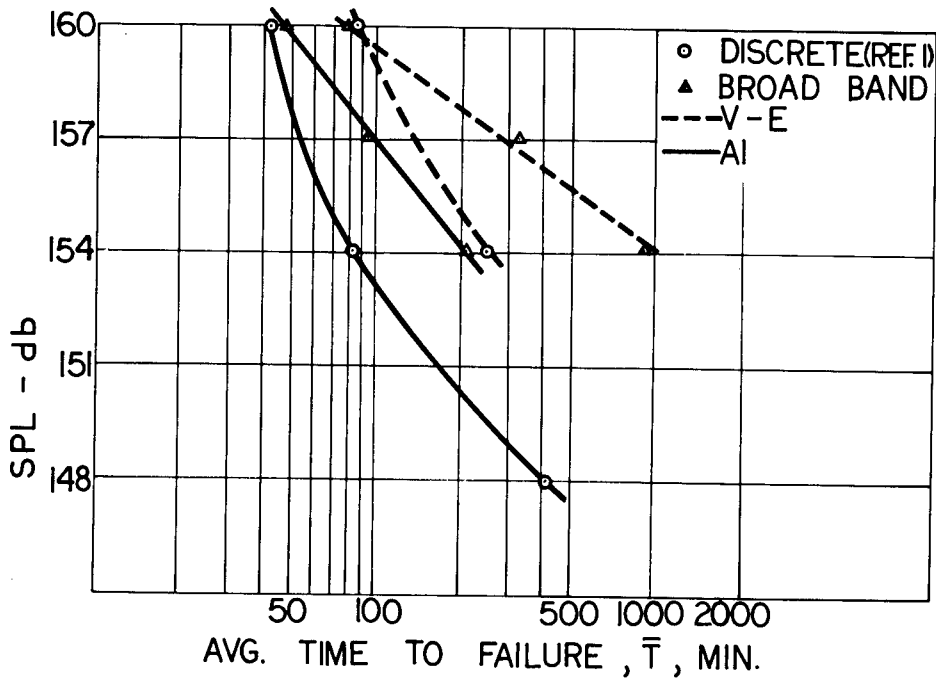

FIG. 15 COMPARISON OF PANEL FATIGUE LIFE AT DISCRETE AND BROAD BAND TESTING

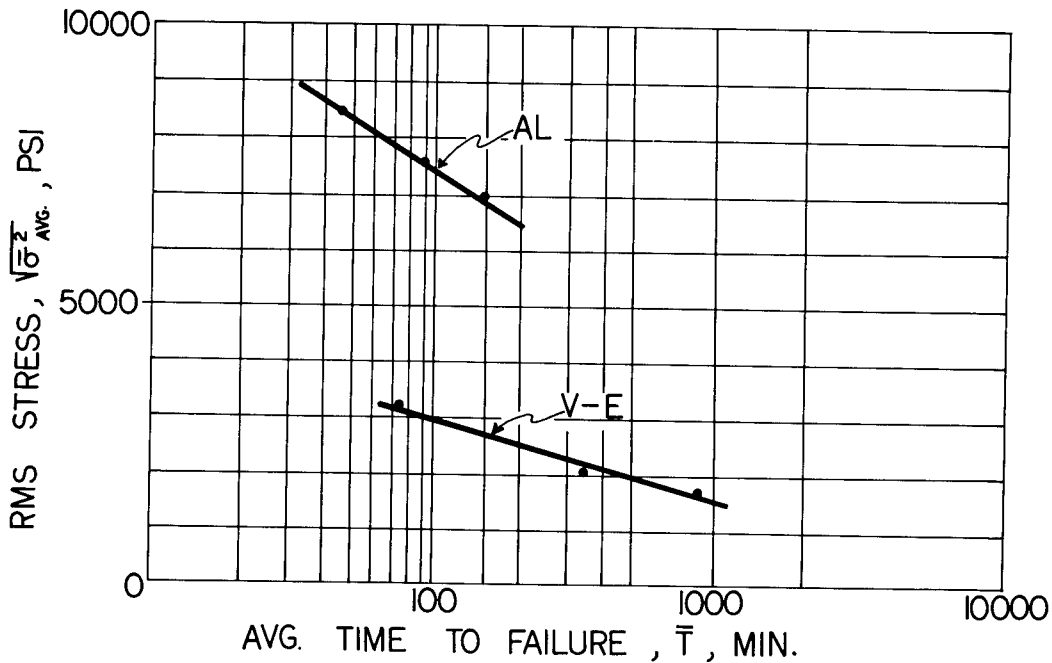

FIG. 16 FATIGUE LIFE OF VISCOELASTIC AND ALUMINUM PANELS AS A FUNCTION OF THE AVERAGE ROOT-MEAN-SQUARE STRESS AT THE PREDOMINATE RESPONSE FREQUENCY FOR RANDOM LOADING (14.2 CPS BW)

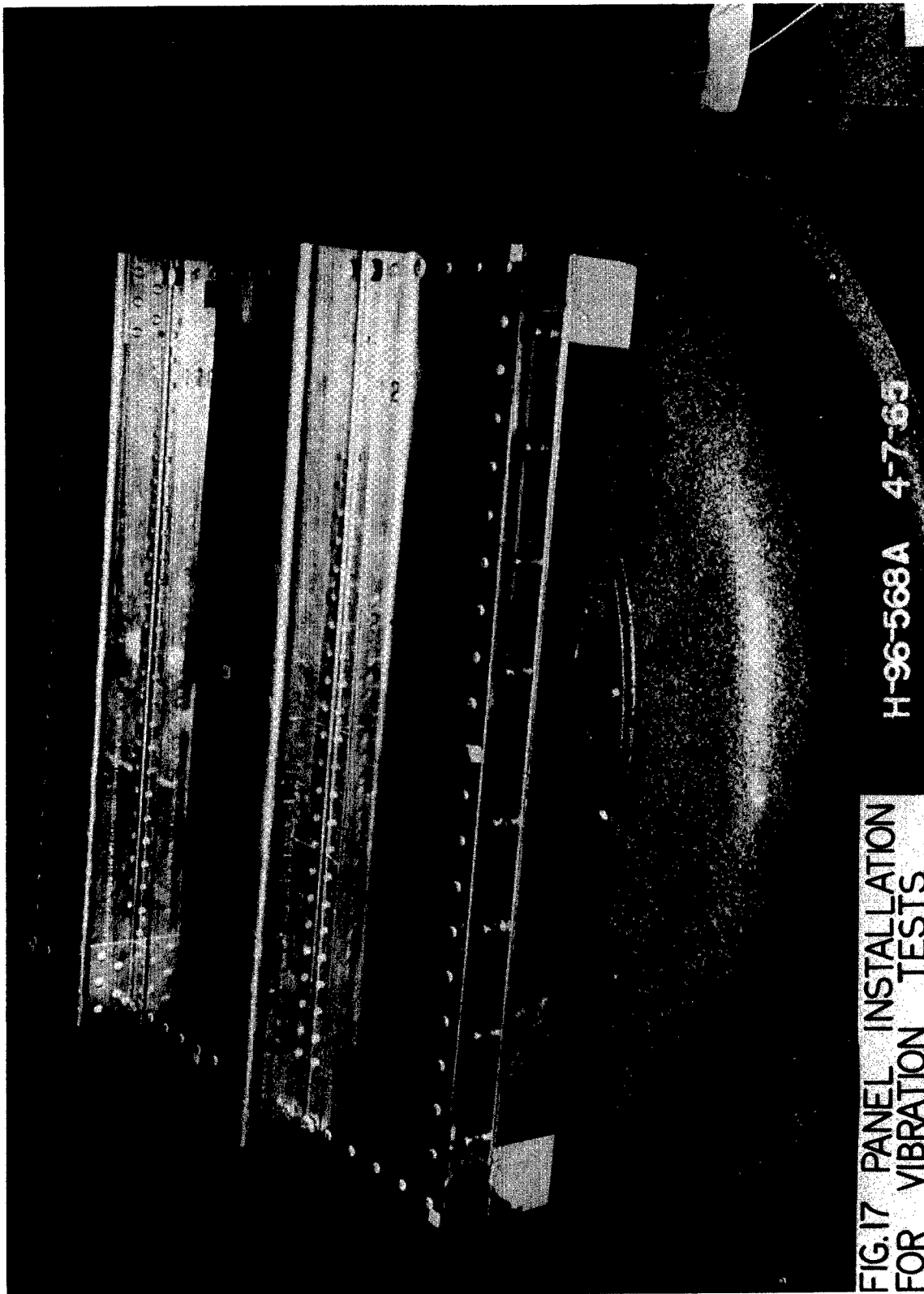

FIG.17 PANEL INSTALLATION  
FOR VIBRATION TESTS

H-96-568A 4-7-69

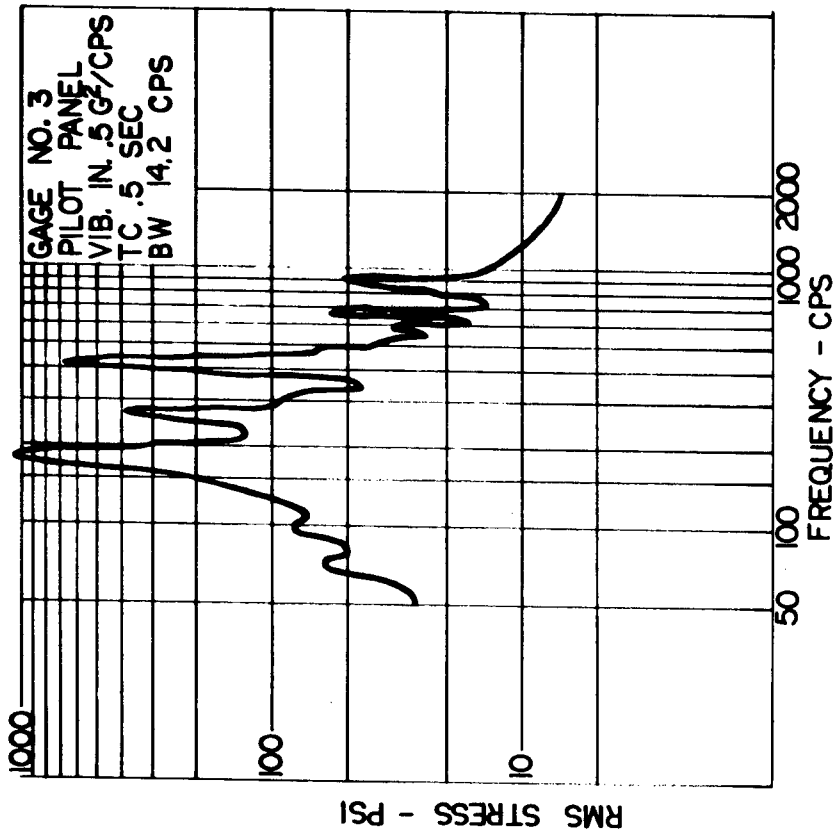

FIG. 19 RMS STRESS RESPONSE OF ALUMINUM CONTROL PANEL DURING SHAKER EXCITATION

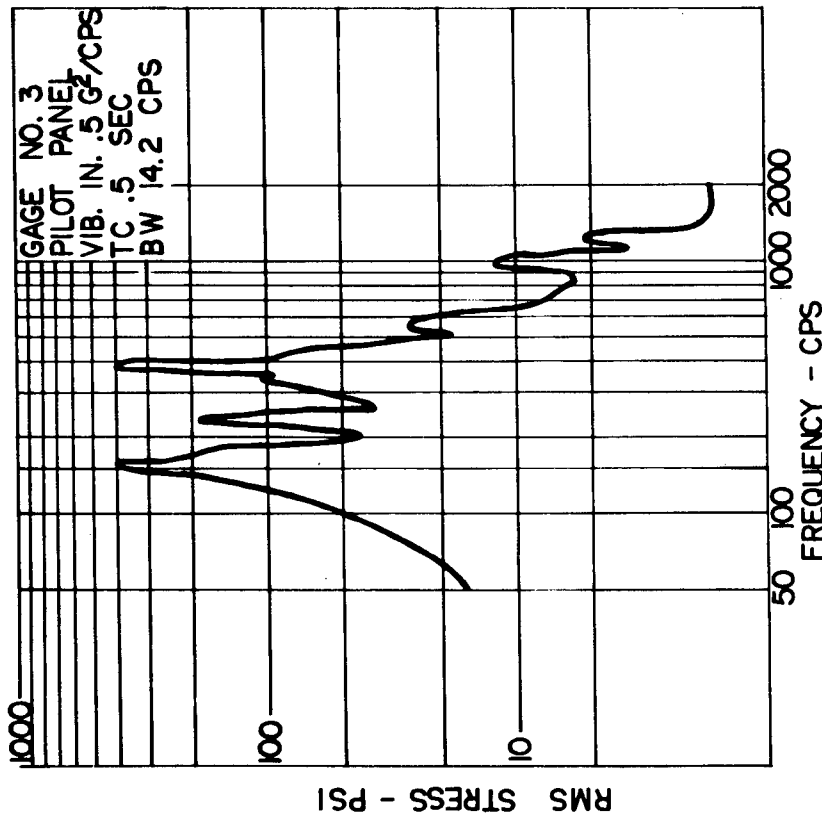

FIG. 18 RMS STRESS RESPONSE OF VISCOELASTIC PANEL DURING SHAKER EXCITATION

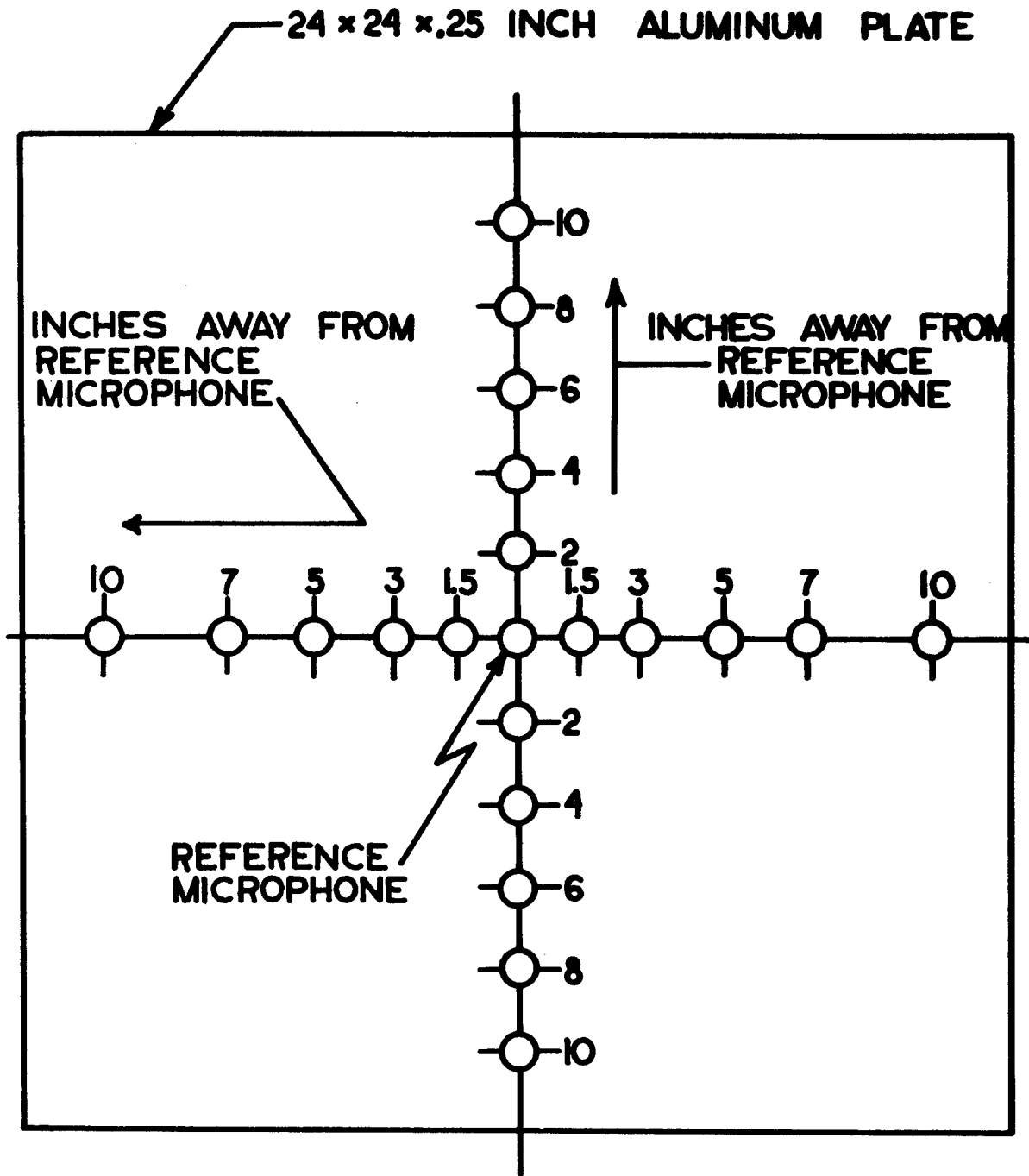

FIG.20 MICROPHONE POSITIONS IN DUMMY PANEL FOR CORRELATION MEASUREMENTS

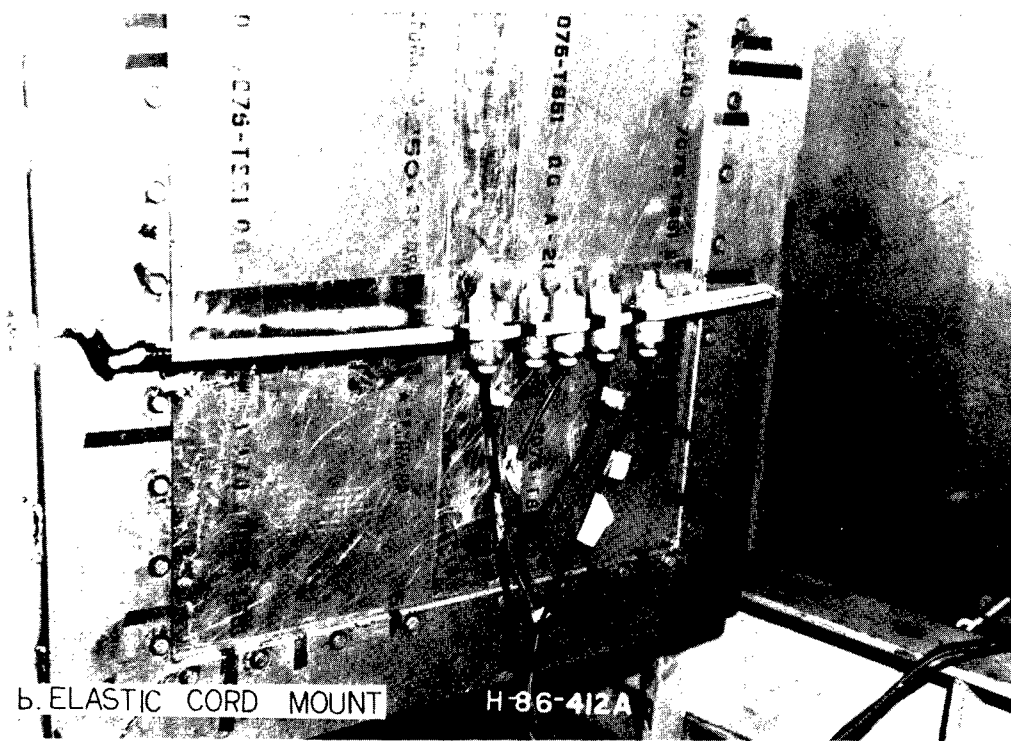

FIG. 21 ARRANGEMENT OF MICROPHONES FOR CORRELATION STUDY

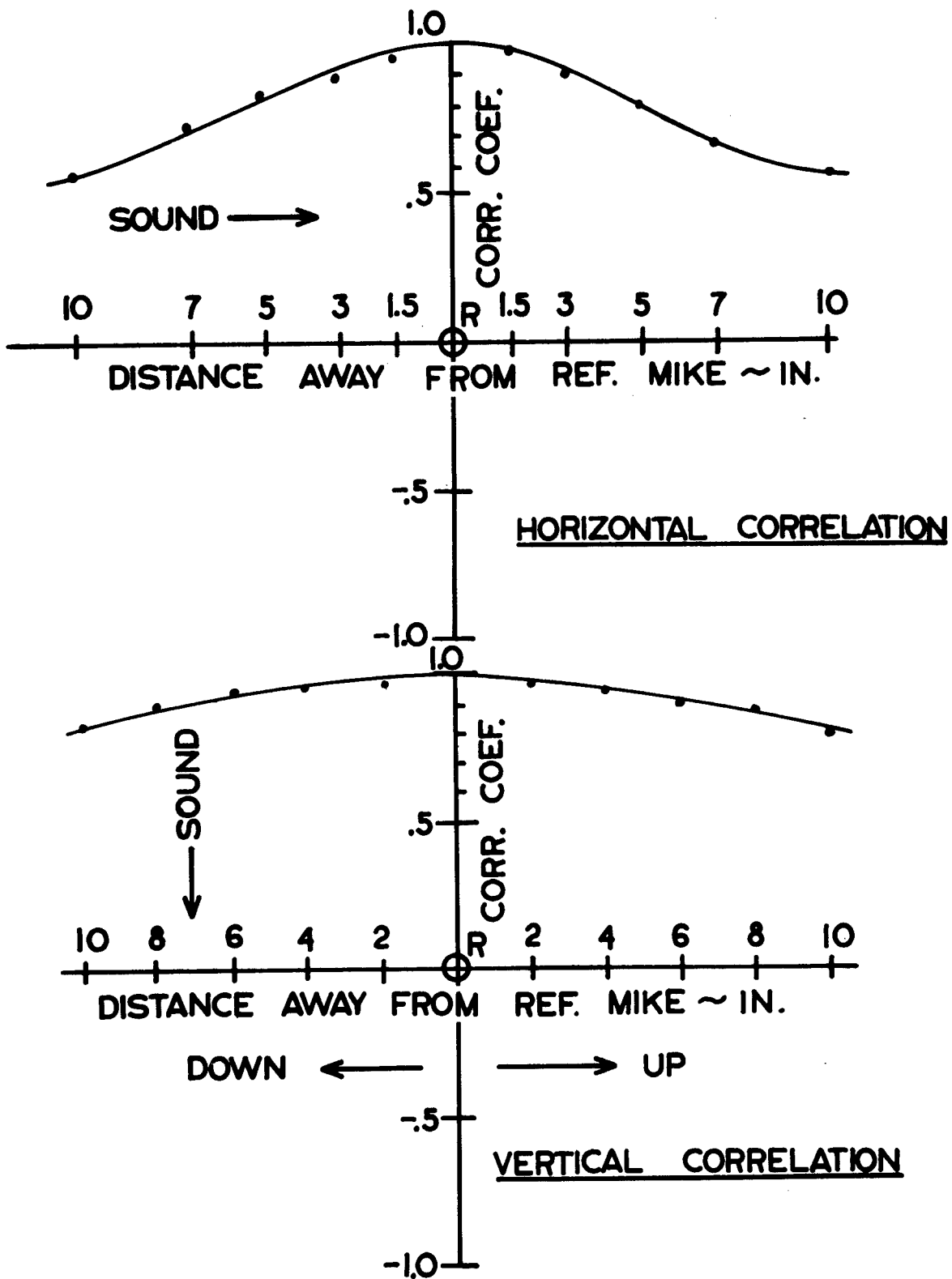
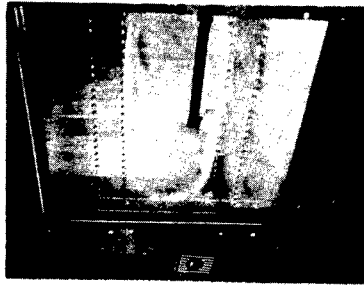

FIG. 22 CORRELATION MEASUREMENTS ACROSS A DUMMY PANEL

V-E PANEL



$f = 153.3$

AL PANEL



$f = 161.5$

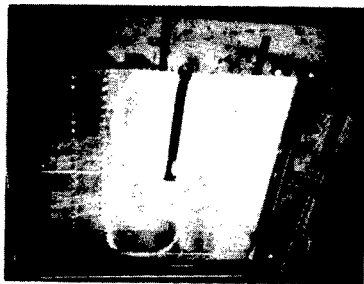

$f = 195.7$

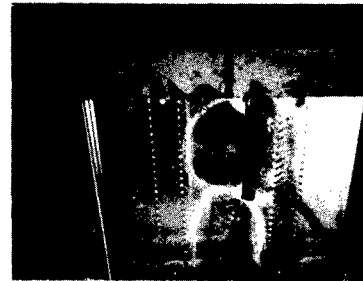

$f = 206.7$

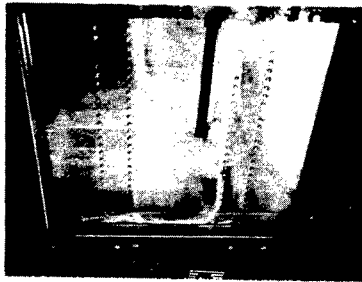

$f = 250.6$



$f = 260.3$

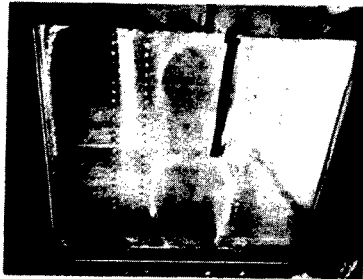

$f = 270.5$

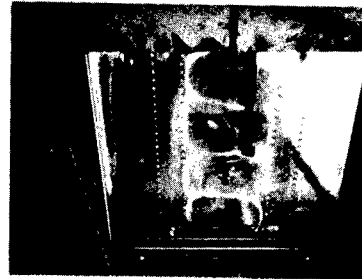

$f = 339.7$

FIG. 23 NODE LINES OF FUNDAMENTAL MODES OF ALUMINUM AND VISCOELASTIC PANELS - SOFT SUSPENSION SYSTEM

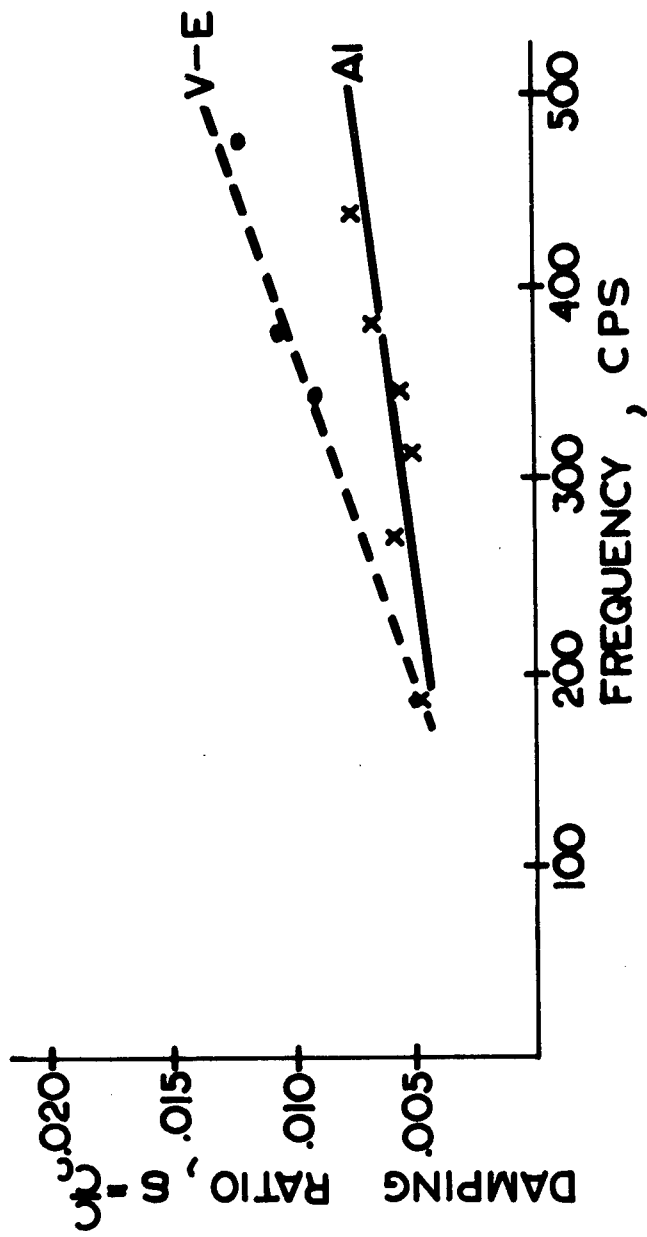

FIG. 24 DAMPING RATIO OF VISCOELASTIC AND AI PANELS - HARD MOUNT

*"The aeronautical and space activities of the United States shall be conducted so as to contribute . . . to the expansion of human knowledge of phenomena in the atmosphere and space. The Administration shall provide for the widest practicable and appropriate dissemination of information concerning its activities and the results thereof."*

—NATIONAL AERONAUTICS AND SPACE ACT OF 1958

## NASA SCIENTIFIC AND TECHNICAL PUBLICATIONS

**TECHNICAL REPORTS:** Scientific and technical information considered important, complete, and a lasting contribution to existing knowledge.

**TECHNICAL NOTES:** Information less broad in scope but nevertheless of importance as a contribution to existing knowledge.

**TECHNICAL MEMORANDUMS:** Information receiving limited distribution because of preliminary data, security classification, or other reasons.

**CONTRACTOR REPORTS:** Technical information generated in connection with a NASA contract or grant and released under NASA auspices.

**TECHNICAL TRANSLATIONS:** Information published in a foreign language considered to merit NASA distribution in English.

**TECHNICAL REPRINTS:** Information derived from NASA activities and initially published in the form of journal articles.

**SPECIAL PUBLICATIONS:** Information derived from or of value to NASA activities but not necessarily reporting the results of individual NASA-programmed scientific efforts. Publications include conference proceedings, monographs, data compilations, handbooks, sourcebooks, and special bibliographies.

*Details on the availability of these publications may be obtained from:*

SCIENTIFIC AND TECHNICAL INFORMATION DIVISION  
NATIONAL AERONAUTICS AND SPACE ADMINISTRATION

Washington, D.C. 20546