

JPRS 68925

13 April 1977

TRANSLATIONS ON USSR SCIENCE AND TECHNOLOGY  
PHYSICAL SCIENCES AND TECHNOLOGY  
No. 9

**DISTRIBUTION STATEMENT A**  
Approved for Public Release  
Distribution Unlimited

**U. S. JOINT PUBLICATIONS RESEARCH SERVICE**

**Reproduced From  
Best Available Copy**

**20000302 119**

REPRODUCED BY  
**NATIONAL TECHNICAL  
INFORMATION SERVICE**  
U. S. DEPARTMENT OF COMMERCE  
SPRINGFIELD, VA. 22161

---

## NOTE

JPRS publications contain information primarily from foreign newspapers, periodicals and books, but also from news agency transmissions and broadcasts. Materials from foreign-language sources are translated; those from English-language sources are transcribed or reprinted, with the original phrasing and other characteristics retained.

Headlines, editorial reports, and material enclosed in brackets [] are supplied by JPRS. Processing indicators such as [Text] or [Excerpt] in the first line of each item, or following the last line of a brief, indicate how the original information was processed. Where no processing indicator is given, the information was summarized or extracted.

Unfamiliar names rendered phonetically or transliterated are enclosed in parentheses. Words or names preceded by a question mark and enclosed in parentheses were not clear in the original but have been supplied as appropriate in context. Other unattributed parenthetical notes within the body of an item originate with the source. Times within items are as given by source.

The contents of this publication in no way represent the policies, views or attitudes of the U.S. Government.

## PROCUREMENT OF PUBLICATIONS

JPRS publications may be ordered from the National Technical Information Service, Springfield, Virginia 22151. In ordering, it is recommended that the JPRS number, title, date and author, if applicable, of publication be cited.

Current JPRS publications are announced in Government Reports Announcements issued semi-monthly by the National Technical Information Service, and are listed in the Monthly Catalog of U.S. Government Publications issued by the Superintendent of Documents, U.S. Government Printing Office, Washington, D.C. 20402.

Indexes to this report (by keyword, author, personal names, title and series) are available through Bell & Howell, Old Mansfield Road, Wooster, Ohio, 44691.

Correspondence pertaining to matters other than procurement may be addressed to Joint Publications Research Service, 1000 North Glebe Road, Arlington, Virginia 22201.

<b>BIBLIOGRAPHIC DATA SHEET</b>		1. Report No. JPRS 68925	2.	3. Recipient's Accession No.
4. Title and Subtitle TRANSLATIONS ON USSR SCIENCE AND TECHNOLOGY - PHYSICAL SCIENCES AND TECHNOLOGY No. 9		5. Report Date 13 April 1977		6.
7. Author(s)		8. Performing Organization Repr. No.		
9. Performing Organization Name and Address Joint Publications Research Service 1000 North Glebe Road Arlington, Virginia 22201		10. Project/Task/Work Unit No.		11. Contract/Grant No.
12. Sponsoring Organization Name and Address  As above		13. Type of Report & Period Covered		14.
15. Supplementary Notes				
16. Abstracts  The report contains information on aeronautics; astronomy and astrophysics; atmospheric sciences; chemistry; earth sciences and oceanography; electronics and electrical engineering; energy conversion; materials; mathematical sciences; cybernetics, computers; mechanical, industrial, civil, and marine engineering; methods and equipment; missile technology; navigation, communications, detection, and countermeasures, nuclear science and technology; ordnance; physics; propulsion and fuels; space technology; and scientists and scientific organization in the physical sciences.				
17. Key Words and Document Analysis.		17a. Descriptors		
USSR		Electronics	Missile Technology	
Aeronautics		Electrical Engineering	Navigation and	
Astronomy		Energy Conversion	Communications	
Astrophysics		Materials	Detection and	
Atmospheric Sciences		Mathematics	Countermeasures	
Chemistry		Mechanical Engineering	Nuclear Science and	
Computers		Civil Engineering	Technology	
Cybernetics		Industrial Engineering	Ordnance	
Earth Sciences		Marine Engineering	Physics	
Oceanography		Methods	Propulsion and Fuels	
17b. Identifiers/Open-Ended Terms		Equipment	Space Technology	
17c. COSATI Field/Group 01,03,04,07,08,09,10,11,12,13,14,16,17,18,19,20,21,22				
18. Availability Statement Unlimited Availability Sold by NTIS Springfield, Virginia 22151		19. Security Class (This Report) UNCLASSIFIED	21. No. of Pages 44	
		20. Security Class (This Page) UNCLASSIFIED	22. Price PC A03	

13 April 1977

TRANSLATIONS ON USSR SCIENCE AND TECHNOLOGY  
 PHYSICAL SCIENCES AND TECHNOLOGY

No. 9

## CONTENTS

PAGE

## SCIENTISTS AND SCIENTIFIC ORGANIZATIONS

A Communique Concerning the Meeting of Presidents of Academies of Sciences of Socialist Countries (PRAVDA, 19 Feb 77) .....	1
Winners of the Medal Imeni M. V. Lomonosov (PRAVDA, 12 Feb 77) .....	5
Articles by Academician M. A. Lavrent'yev (M. A. Lavrent'yev; SPISANIE NA BULGARSKATA AKADEMIYA NA NAUKITE, No 5, 1976) .....	8
Siberian Department of USSR Academy of Sciences (G. I. Marchuk; SOVETSKAYA ROSSIYA, 21 Jan 77) .....	32
Scientific, Technical Entries for Georgian SSR State Prize (ZARYA VOSTOKA, 5 Jan 77) .....	38

## SCIENTISTS AND SCIENTIFIC ORGANIZATIONS

### A COMMUNIQUE CONCERNING THE MEETING OF PRESIDENTS OF ACADEMIES OF SCIENCES OF SOCIALIST COUNTRIES

Moscow PRAVDA in Russian 19 Feb 77 p 4

[Text] The Conference of Presidents of Academies of Sciences of Socialist Countries was held in Moscow from 15 February to 18 February 1977. Participants included: president of the Bulgarian Academy of Sciences, academician Angel Balevski, acting president of the Hungarian Academy of Sciences, academician Janosh Szentagothai, chairman of the Committee of Social Sciences of the SRV [North Vietnam] Nguyen Khanh' Toan, president of the Academy of Sciences of the GDR [Eastern Germany] academician Hermann Klare, president of the Academy of Sciences of Cuba, Doctor Wilfredo Torres Yribar, president of the Academy of Sciences of the MNR [Mongolian People's Republic] academician Bazaryn Shirendyb, president of the Polish Academy of Sciences, academician Wlodzimierz Tqzebiatowski, president of the Academy of Social and Political Sciences of the SRR [People's Republic of Romania] professor Mihnea Gheorghiu, vice-president of the Academy of the SRR academician Ioan Cetrechi, president of the Academy of Sciences of the USSR academician Anatoliy Petrovich Aleksandrov and chairman of the Czechoslovakian Academy of Sciences, academician Jaroslav Kozesnik.

Secretary General of the Central Committee CPSU Leonid Il'ich Brezhnev received the directors of the academies. In the course of conversations conducted in a cordial and comradely atmosphere, opinions were exchanged on questions of cooperation of academies of sciences of the sister nations, further increase of the role of science in the solution of problems of the socialist construction and the Communist construction, and participation of scientists of the socialist countries in the struggle for the strengthening of peace throughout the world.

In conformity to tasks assigned to science by Decrees of Congresses of Communist and Workers' Parties, discussions were conducted at the conference of presidents on a wide range of vital problems of development of science and the increase of the effectiveness of scientific research, the present state and prospects of cooperation of scientists of the socialist countries, joint solution of the leading problems of the natural sciences and social sciences and the acceleration of the introduction of the achievements of science into the national economy of the socialist countries.

Conference participants visited several institutes and scientific centers of the Academy of Sciences of the USSR and witnessed the results of Soviet research in different sectors of knowledge.

Presidents of the academies emphasized that socialism opens boundless prospects for the development of science. Scientists of socialist countries have made important achievements in several major areas of contemporary science. At the same time, socialism is most completely, sequentially and effectively realizing the higher achievements of science in the interests of the workers, in the interests of social progress. The conditions of socialism reveal most clearly the humanistic essence of scientific knowledge, its trend toward peaceful purposes, toward the harmonic development of man and society. The previously unrevealed prospects of spiritual and material progress of the socialist society are shown by the present-day scientific and technical revolution.

Recent Congresses of Communist and Workers' Parties of Socialist Countries have praised the role of science and of scientists in the socialist and Communist constructions and have presented science with new, inspiring tasks. The contribution of the academies to the construction of the new society was reported to the conference. Each academy, in conformity to the problems being solved in their own country, is implementing an extensive program of fundamental research which is closely intertwined with practical needs. Conference participants heard a report concerning the major achievements in key sectors of knowledge.

Directors of the academies of sciences noted with satisfaction the constant expansion and strengthening of the scientific connections of socialist countries. Ideological unity, political cohesion, international solidarity, mighty production, potential and developing economic cooperation and integration of the sister nations open the most extensive horizons of scientific cooperation. This cooperation will increase many fold the scientific opportunities of the socialist countries and will serve as a reliable basis of coordination of efforts in the solution of the most complex and vital problems.

Conference participants stated that cooperation of the academies of sciences in recent years was carried out fruitfully on the basis of multilateral and bilateral agreements and also within the frameworks of the Council of Mutual Economic Assistance. Obvious examples of such cooperation are the joint programs in the areas of space research, earth science, physics, chemistry and biology. Results of creative cooperation in the area of the social sciences and information concerning the work of the Second Conference of Vice-Presidents on the Social Sciences (Warsaw 1971) were presented at the conference. The presidents noted with satisfaction that

the scientific associations in basic branches of humanitarian sciences are being consolidated yearly and are becoming more effective. They praised the long-term program of cooperation in the social sciences.

The great ideological-political significance of joint work in the study and generalization of the historical experience and international role of the Great October Socialist Revolution, the 60th anniversary of which will be commemorated this year by the Soviet peoples, the peoples of the sister socialist republics and all progressive humanities was emphasized.

Conference participants gave the greatest attention to problems of the increase of effectiveness of scientific research. In respect to this, there were discussions of problems of the further acceleration of development of scientific instrument manufacture, computer technology and automation of experiments as a major element in the intensification of research. In order to increase the effectiveness of joint work in this region, the presidents recommended the concentration of efforts on the development of a unified technical policy of the sister academies of sciences, classification and standardization of design decisions for creation of new devices and systems of automation of scientific research. A coordination committee was formed on a basis of parity for solution of fundamental problems and coordination of work in these areas.

Conference participants stated that, in our epoch, together with the conquests of new peaks in understanding the secrets of the universe, scientific thought has produced the opportunity for creation of weapons of mass destruction which constitute a danger to the entire planet. Under such conditions, it is especially necessary that scientists working in different areas of science, unify and increase their efforts in a persistent and purposeful struggle for strengthening peace.

Conference participants unanimously stressed that, in recent years, thanks to the great successes of the world revolutionary movement, the energetic efforts of socialist states, other peace-loving forces, all progressive societies have achieved positive shifts in the matter of easing political tension and peaceful coexistence of states with different social structures.

Under present-day conditions, the prevention of war by easing political tension is of special importance. Conference participants expressed their deep conviction that scientists, recognizing their responsibility to history, must exert all of their influence for ensuring the end of the arms race and begin the era of universal disarmament.

The presidents of the Academies of Sciences emphasized that scientists of the socialist countries are prepared to combine their efforts, in the future, with scientists of all countries of the world in the solution of the

most important problems common to all mankind such as problems of energy, raw materials, productivity, environmental protection, rational assimilation of the resources of the World Ocean and control of epidemics.

Presidents of the Academies of Sciences of Socialist Countries noted with great satisfaction that their first meeting, convened in Moscow, proceeded in a friendly, creative atmosphere. Specific agreements were reached on all of the problems discusses.

2791

CSO: 1870

SCIENTISTS AND SCIENTIFIC ORGANIZATIONS

WINNERS OF THE MEDAL IMENI M.V. LOMONOSOV

Moscow PRAVDA in Russian. 12 Feb 77. p 3

Text The Presidium of the Academy of Sciences of the USSR awarded the gold medal imeni M.V. Lomonosov for 1976 to Academician S.I. Vol'fkovich for outstanding achievements in the area of the chemistry and technology

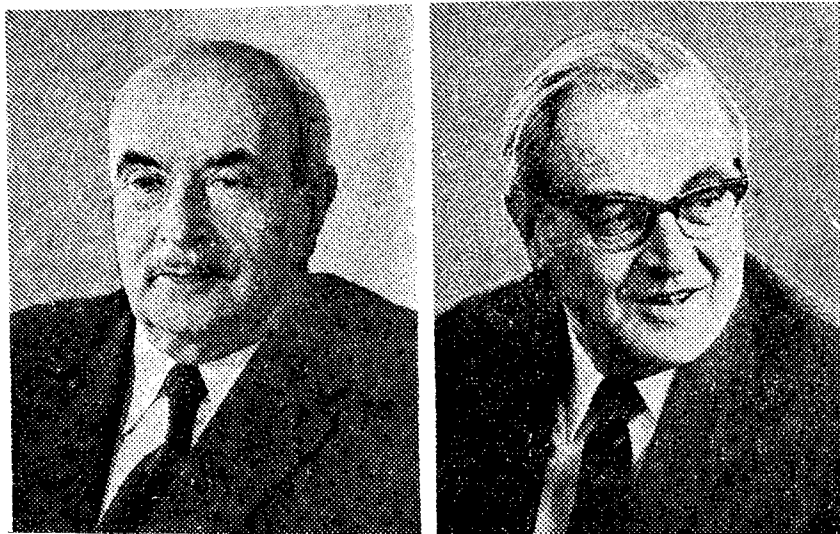

S.I. Vol'fkovich

Herman Klare

of phosphorus and the development of scientific principles of the chemization of agriculture and to active member of the Academy of Sciences of the GDR Eastern Germany Herman Klare for outstanding achievements in the area of the chemistry and technology of man-made fibers. The gold medal imeni M.V. Lomonosov is the highest award of the Academy of Sciences of the USSR and is awarded annually (one to a Soviet scientist and one to a foreign scientist) for outstanding achievements in the natural sciences.

Academician S.I. Vol'fkovich is an eminent Soviet scientist in the area of chemistry and chemical technology and the development of the scientific principles of the chemization of agriculture. His Scientific interests are closely associated with problems of the chemistry and technology of mineral fertilizers, fodders, pesticides and salts.

S.I. Vol'fkovich obtained especially important results during the working out of problems of the chemistry and technology of phosphorous. He was the first in our country to study electrothermal volatilization of phosphorous from domestic raw material. He directed studies of the complex processing of Khibiny Mountains apatites by acid, alkaline and hydrothermal methods with production of fertilizers, flouride salts and rare earths and also a power-technological hydrothermal method of producing fodder phosphates.

S.I. Vol'fkovich conducted significant studies of the production of different polyphosphates and also on the modification of properties of phosphorus and its compounds. He studied the physico-chemical conditions of thermal dissociation of phosphates in low-temperature plasma and vacuum electric furnaces with production of phosphorus anhydride.

S.I. Vol'fkovich participates actively in the establishment and development of the Soviet chemical industry. He developed some new production processes which were implemented in industry on the basis of physico-chemical and technological studies of domestic agronomic ores. He participated in the mastery of the first ammonia synthesis plant, directed plant experiments on nitric acid processing of phosphates, and was one of the initiators of production of synthetic urea in the USSR.

He is one of the authors of a flow chart for production of potassium chloride from sylvinit and he proposed a method of processing carnallite. His name is associated with fundamental studies for chemization of agriculture. He is the author of several monographs, textbook, nearly 100 inventions and 500 scientific articles.

S.I. Vol'fkovich has been awarded the Order of Lenin five times, the Order of the Labor Red Banner, the State Prize of USSR and the gold medal imeni D.I. Mendelejev.

President of the Academy of Sciences of the GDR, Academician Herman Klare is an eminent specialist in the chemistry and the technology of man-made fibers. In his diverse scientific activity, he places special emphasis on work associated with the study of cellulose, polyamides and other polymers used for producing man-made fibers. His studies in this area constitute a major contribution to the development of the chemical fibers industry.

An important series of Klare's investigations involve the study of the process of formation of viscous fiber. His studies of the effect of the composition of the spinning bath on the physico-mechanical properties of viscous fiber are of great practical importance. On the basis of these studies, he proposed an efficient method of producing high-quality cord thread.

He gave special attention to a study of processes of producing synthetic fibers on the basis of polyethers and polyamides. Specifically, he solved the problem of production of the initial products for polyester fiber. His studies of the polymerization of caprolactam and the subsequent processes of the formation and drawing of polyamide fibers provided a method for the substantial intensification of their production and the improvement of their quality. He summarized the results of these studies in the monographs "The Chemistry and Technology of Polyamide Fibers" and "Synthetic Polyamide Fibers."

Herman Klare is a foreign member of the Academy of Sciences of the USSR and of the Polish and Czechoslovakian Academies of Sciences. He was awarded the GDR National Prize two times.

2791  
CSO: 1870

## SCIENTISTS AND SCIENTIFIC ORGANIZATIONS

### ARTICLES BY ACADEMICIAN M. A. LAVRENT'YEV

Sofia SPISANIE NA BULGARSKATA AKADEMIYA NA NAUKITE in Bulgarian No 5, 1976  
pp 19-39

[Articles by Academician M. A. Lavrent'yev in "Interviews With Foreign Members of the Bulgarian Academy of Sciences"]

[Text] In the present issue of the journal, the editorial board is continuing to publish interviews with the foreign members of the BAN [Bulgarian Academy of Sciences]. Below we are printing materials by Academician M. A. Lavrent'yev who was so kind to respond to our request for participating in this series. Upon his request we are publishing three articles by him which (as he himself stresses) "provide a complete answer to the questions posed by the editorial board." Academician Lavrent'yev feels that the problems of forecasting and combating natural calamities, the problems of hydrodynamics of the seas, the strengthening of shores and so forth are of enormous significance on a world scale.

Below we are printing a brief biographical sketch of him and the articles sent to us.

[Biographical sketch] Academician M. A. Lavrent'yev was born on 19 November 1900 in Kazan'. In 1918-1921, he was a student at the Physics and Mathematics Faculty of Kazan' University, and in 1922, was living in Moscow where he completed his higher education at the Physics and Mathematics Faculty of Moscow Univeristy. After completing the university, he worked as an assistant, and later as a docent at the Moscow Higher Technical School. He commenced his scientific activities while at Moscow University under the leadership of N. N. Luzin, and later as his graduate student, specialized in the area of the theory of the functions of a true variable. In 1926, he defended his graduate student dissertation devoted to homeomorphic sets, and in the following year was elected a member of the Moscow Mathematical Society. In 1929, he became the leader of the Mathematics Chair Under the Moscow Chemical Engineering Institute. During the same

year he commenced work as a senior engineer at the Central Aerohydrodynamics Institute imeni N. Ye. Zhukovskiy. Here, under the leadership of the prominent Soviet scientist S. A. Chaplygin, academician Lavrent'yev obtained his second specialty in aero- and hydrodynamics, in which, he, as in the theory of the functions of a complex variable, attained exceptional successes. From that time commenced his direct activities in the area of applied mathematics. From 1931, Academician Lavrent'yev was a professor at Moscow University. In 1934, he was awarded the academic degree "Doctor of Technical Sciences," and in 1935, "Doctor of Physicomathematical Sciences." In the same year, he was invited to work as a senior science associate at the Mathematics Institute imeni V. A. Steklov under the USSR Academy of Sciences. For 20 years, he led its Department for Function Theory which he himself had set up. By universal recognition, since that time, Academician Lavrent'yev became the founder of the Soviet school of function theory. He made a great contribution to the development of mathematics in the various republics of the USSR. In 1939, he was elected an active member of the Ukrainian Academy of Sciences, and was appointed director of the Mathematics Institute under the academy. During the time of the Patriotic War, he was living and working in Ufa, where the Ukrainian Academy of Sciences was located. For great achievements in the area of military technology, in 1944, Academician Lavrent'yev received the Order of the Patriotic War Second Degree, and in 1945, the Order of the Red Banner. In 1946, he was elected the deputy chairman of the Ukrainian Academy of Sciences and an active member of the USSR Academy of Sciences. In the same year he received the State Prize First Degree, and was awarded it a second time in 1949. Academician Lavrent'yev returned to work at Moscow University in 1948, and took an active part in setting up the Physics Engineering Faculty at the university. He was one of the initiators for creating the Institute for Theoretical Mechanics and Computers, and in 1949, was elected its director. In 1950-1953 and 1955-1959, he was the academician secretary of the Department of Physicomathematical Sciences and a member of the Predisium of the USSR Academy of Sciences (in 1955). In 1952, Academician Lavrent'yev joined the CPSU, and in 1953, received the Order of Lenin. He was elected the deputy chairman of the USSR Academy of Sciences in 1957. In the same year, the decree was promulgated of the CPSU Central Committee and the USSR Council of Ministers for the setting up of the Siberian Division of the USSR Academy of Sciences. Academician Lavrent'yev was elected its chairman. Under his direct leadership, construction was started on a complex of buildings at the Novosibirsk scientific center. The first to begin working was the Hydrodynamics Institute of which Academician Lavrent'yev was the organizer and director. In subsequent years the Siberian Division of the USSR Academy of Sciences carried out major research in a number of the basic areas of modern science, and obtained wide renown in the USSR and abroad. The fundamental scientific research carried out by the Siberian Division has been widely employed in solving urgent problems related to the development of the productive forces in Siberia, the Far East and the European USSR. In 1958, Academician Lavrent'yev was elected a member of the Novosibirskaya Oblast Party Committee, and a deputy to the USSR Supreme Soviet, and at the 22d, 23d and 24th party congresses, was elected a candidate member of the CPSU

Central Committee. From 1967, he was a deputy of the Novosibirskaya Oblast Soviet. Academician Lavrent'yev has participated as a member of editorial boards on a number of scientific journals (SIBIRSKIY MATEMATICHESKIY ZHURNAL [Siberian Mathematical Journal], ZHURNAL PRIKLADNOY MEKhanIKI I TEKHnICHESKOY FIZIKI [Journal of Applied Mechanics and Technical Physics], and others), and from 1946 has been the editor-in-chief of the journal FIZIKA GORENIYA I VZRYVA [Physics of Combustion and Explosives]. On the occasion of the 10th anniversary of the Siberian Division of the USSR Academy of Sciences and for his exceptional services in the development of science and the organizing of the Siberian Division, in 1967, Academician Lavrent'yev received the title of Hero of Socialist Labor, the Order of Lenin and the gold medal Hammer and Sickle. Academician Lavrent'yev has devoted great attention to the development of international ties among mathematicians. He has organized a number of international symposiums and has repeatedly led Soviet delegations to scientific conferences abroad. He is a member of a number of foreign academies including the CSSR Academy of Sciences, the BAN, the GDR Academy of Sciences, the Academie Française and others. From 1966 until 1970, he was the vice president of the International Mathematics Union.

From the Editorial Board

#### Mechanics and Scientific-Technical Progress

Mechanics, like all of science, is inseparably linked with technical progress. The development of new technology is impossible without the use of mathematics, computer mathematics, mechanics, physics and chemistry. There is also feedback as many scientific problems can be solved only with the extensive use of the entire might of modern industry. While during the times of Euler and even much later, even before the 1950's, science developed in the universities, and laboratories occupied several rooms, at present entire cities are built frequently for the sake of scientific problems, and here the efforts of many scientists from different areas are joined with those of prominent designers. The work is carried out according to a strictly determined plan, and the problems of nuclear power and the problems of outer space are solved in this manner.

At the same time, the experience of both yesterday and today indicates that even with few opportunities, scientists aided by young groups are able to make discoveries which provide an impetus to scientific and technical progress; examples would be the chain reaction of Semenov, the lasers of Prokhorov and Basov, and others. Norbert Wiener and John von Neumann also, without hiring large collectives, propounded the principles of electronic computers.

There are many other vivid examples where new scientific problems are born at plants, and are born out of the major tasks of the national economy and in the struggle against the vicissitudes of nature.

The scale of the work in the area of mechanics can be judged from the three volumes of the recently published book "Mekhanika v SSSR za 50 Let" [Mechanics in the USSR During 50 Years]. At the end of each volume there is an index of the names of authors quoted in the book, and the figures are approximately as follows:

General and applied mechanics	--1,500
Fluid and gas mechanics	--3,000
Malleable solids mechanics	<u>--1,000</u>
	5,500

I will limit myself to the problems of just several areas of mechanics which are close to my interests and which in recent decades have been substantially developed both in theory and in technology.

#### A. Fluids and Gases

This area of mechanics--hydrodynamics--has, like the others, been greatly developed. Enormous experimental material has been acquired and numerous mathematical models have been constructed. Hydrodynamics is the basis of shipbuilding, aviation, the study of the movement of seas, oceans and the atmosphere.

I will take up two problems.

1. Nonstationary motion. If a rod is driven to the bottom in a rapid flow, then not only will it be deflected in the direction of the motion, but will also begin to make oscillatory movements perpendicular to the rate of flow. A study of this phenomenon is of great significance both for shipbuilding and for aviation. At the high speed the periscope of a submarine may be broken off; on an airplane a wing may be torn off (flutter).

In the USSR, the first experimental and theoretical research was started in the past century by A. N. Krylov, N. Ye. Zhukovskiy and S. A. Chaplygin. As a mathematical model, the equations for a rigid ideal fluid were used, but in the 1920's it was clear that the model was obsolete. It was essential to take into account both the viscosity and flexibility, that is, to utilize equations (more complicated ones) of gas dynamics, and in considering the formation of vortices.

These questions were particularly crucial in the 1930's, when the speed of airplanes began to rise.

Upon the initiative of Tupolev, Keldysh, Sedov, Petrov and others were brought in for joint work with his closest assistants, the engineers and designers, for working at the TsAGI [Central Institute of Aerohydrodynamics]. The combining of theory with practice soon began to produce results.

This research assumed particularly great significance during the period of the Great Patriotic War. Much of the research was also used in solving the problems of space and nuclear power.

2. Turbulence. Let us assume that water under pressure  $P$  is delivered into a smooth-surface pipe with a diameter of 0.5 m and a length of 10 m. With an increase in pressure, the velocity rises, and the globules with the density of water released in the pipe fly at the speed of the flow. Experiments have shown that each pipe has its  $P_{cr}$ ; if  $P > P_{cr}$ , then the globules (particles of fluid) acquire a velocity with large components directed perpendicular to the axis of the pipe. The tractive resistance rises by several fold, the globules move at a high velocity between the axes of the pipe and its surface. We say that the flow has changed from laminar to turbulent. This phenomenon was discovered many years ago, and throughout the world hundreds of papers have been published on experiments and an attempt has been made to create a theory.

a) In the area of the theory of isotropic turbulence, atmospheric turbulence and the theory of turbulent mixing of flows, rather important results have been obtained in the USSR. We should particularly note the work of Kolmogorov, Sedov and Abramovich (Moscow) and Kobets and Tet'yanko (Novosibirsk).

The theory and practice of turbulence underlie many important technical discoveries.

b) In experiments, a polymer has been discovered with long molecules with unusual properties. A very slight addition of this polymer (on the order of 0.01 percent) to water increases by several fold the  $P_{cr}$ , and greatly reduces the hydrodynamic drag.

3. Vortical rings. Smoke rings have long been known. This unique and comparatively easily observed hydrodynamic phenomenon has attracted and is attracting the attention of many researchers. The interest in this phenomenon is due, on the one hand, to the difficult problems of a physical and mathematical character arising in the attempt to create a theory for this phenomenon, and, on the other, to the possibility of utilizing this phenomenon to explain a number of mysterious phenomena in the seas, oceans and atmosphere.

Regardless of the large number of works devoted to this problem, many important and interesting questions relating to it have as yet remained unanswered. The research conducted in the last decade at Akademgorodok (by B. A. Lugovtsov) has provided a strong impetus in this area. Numerous experiments were conducted, on the basis of which a mathematical model was created making it possible to define the law of motion, the structure of vortical rings, the quantity of admixtures which they can carry, and other characteristics. But what is the essence of the phenomenon?

If an ordinary rubber ball is given a velocity of 5-10 m per second, it will cover a distance of 1-2 m. On the other hand, it is well known that if with the same velocity the same mass of air is ejected (for example, it is forced out of a pipe with a plunger) without a cover, then it will travel a distance that is 10-15 fold greater.

Experiments have shown that in the second case, the motion is carried out as is shown in Figure 1, where the lines of the current for the motion are depicted in relation to a coordinate system moving together with the expelled mass of air. The motion acquires axial symmetry; in the enlarged area formed by the rotation of area ABC, this is vortical, and outside this area, practically potential. On the surface of ABC, the velocities of the inside and outside motion coincide, so that the field of velocities is continuous. Precisely this explains the above-described effect: due to the continuity, the friction on the boundary of the mass moving without an envelope is smaller than that of a mass in an envelope, and consequently the lesser drag and the greater distance covered by the mass.

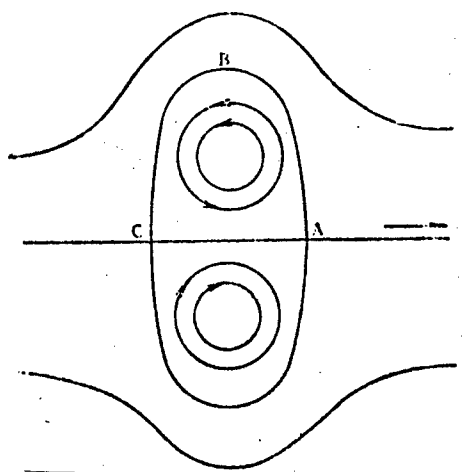

Fig. 1

Analogous motion may also be observed in water. The currents of such a structure are called vortical rings. A characteristic feature of such a current is the line of current ABC (see Fig. 1) separating the area of the current in which the lines of the current are closed from the remaining area of the current in which the lines of the current move from infinity to infinity (in the coordinate system related to the vortical ring). Clearly the fluid located in the area bordered by the line of the current ABC moves together with the vortex. If this area of the fluid in some manner is marked (colored with ink or filled with smoke), then in the fixed coordinate system one can observe the motion of this area of the fluid through the fluid surrounding it.

If the motion of the fluid was laminar, then the shape of the colored portion of the fluid would coincide with the form of the area determined by the line of the current ABC and close to a flattened rotation ellipsoid, while the colored impurity would virtually not be lost by the vortex (if we disregard the slow process of molecular diffusion).

But with the motion of a vortical ring with sufficiently large size and with a significant velocity, the current of the fluid becomes turbulent. As a result of turbulent diffusion, the smoke particles or the colored fluid located around the boundaries of the moving body are rapidly lost by the vortex, and form a characteristic smoke trail strung out behind the vortex. Only visible is the area with a high concentration of smoke particles or dye which represents the ring (torus). This explains the second name for this type of current, smoke rings.

The figures show the motion of smoke rings created in an explosion. In Figure 2, an explosive charge was ignited in an open barrel. In Figure 3,

the smoke ring was obtained from an aimed explosion of a laminar cylindrical barrel with gasoline and the gas was converted into a fire ball.

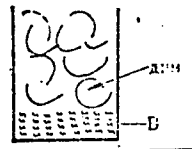

Fig. 2

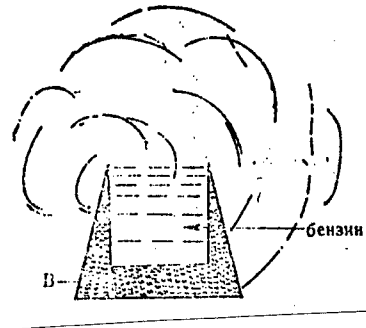

Fig. 3

Underwater storms. In numerous studies of the seas and oceans, many unexpected phenomena have been discovered. I will mention two of them:

- 1) Chaotic motion of water is encountered at a significant depth;
- 2) On the surface waves are observed in the form of a system of swells and depressions placed in a checkerboard pattern.

Possibly the first of these phenomena is related to the effect of motion in a channel, when there are depressions on the bottom of the channel. Figure 4 shows a fluid velocity field when the concavity is rectangular.

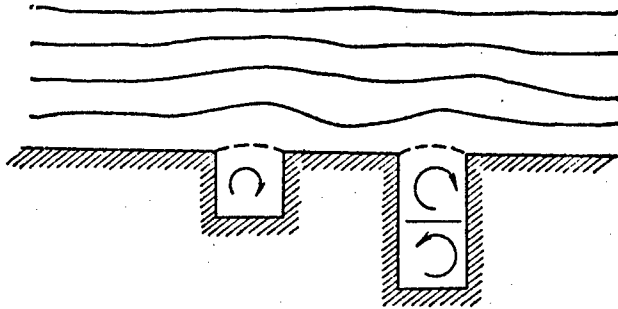

Fig. 4

It is interesting to note that the velocity on the bottom of the concavity "almost" equals the velocity of the flow.

If in the described scheme the bottom vortices are "released" into the basic flow, then these vortices are transformed, they can travel great distances and lead to the effect of an underwater "storm."

The second effect is probably related to a sharp change in wind direction.

All these questions, along with turbulence, have attracted the attention of many scientists, both theoreticians and experimenters. Major successes have been achieved in the USSR and abroad: Favre (Marseilles), Kravtchenko (Grenoble), Lighthill (England), and much work is being done in the United States.

I would also note certain interesting problems in gas dynamics, as well as in the theory of waves of a heavy fluid (seas and oceans). (In gas dynamics, when in the examined area of a current there is a zone where the velocities are subsonic and a zone where the velocities are supersonic.) In the language of a mathematical model, we have a finite problem of differential equations of the combined type, in the portion of the area (subsonic) we have a system of equations of the elliptic type, and in the other area (supersonic), of the hyperbolic type. The first to be concerned with the finite problems of this type was the Italian mathematician Tricomi (1930); later on this area was greatly developed in the work of Frankel', Bitsadze, Babenko, and in recent years at the Computer Center (Dorodnitsyn), where the problems were solved by widely using computers.

The area of unstable conditions remains very little studied, particularly in gas dynamics. This applies above all to the phenomena in the atmosphere. With good reason many have proposed that April first be declared Meteorologists Day. With the present might of science and technology, precisely instability can help replace "prediction" by "effect."

In the area of wave motion, in spite of the fact that the largest number of publications probably is found here, there remain many interesting unsolved problems. Little has been achieved concerning the motion of a fluid across an uneven bottom (the case with three dimensions), and precisely here is the problem of tsunami. An earthquake in the region of the southern latitudes creates a wave which reaches as far as Kamchatka and is capable of destroying entire villages and flooding enormous areas. Among the works in recent years in this area, we should note the very serious work of Garipov on the propagation of waves above a crest, as the crest is an unique waveguide which greatly reduces the height of the wave in moving away from the place of its origin.

Even Stokes showed that a flat wave above a level bottom has a maximum height. Such a wave has been termed a Stokes wave, but up to the present there has been no true theory or proof of the existence of such a wave.

## B. Metal and Hard Rock

The behavior of a metal article with the effect of forces on it is extremely diverse. The classic and most developed is the static problem of given the external forces, it is necessary to determine the deformation of the article and the stresses created in this.

In this area a great deal has been achieved. At present the monograph of N. I. Mushkelishvili has become a classic, as well as the works of his school, and above all I. N. Bekua. These works widely used the methods of function theory of a complex variable and integral equations.

I will take up two problems which have arisen relatively recently.

1. Dynamic instability. Let us examine one group of problems in the theory of elasticity, the theory of stability. This theory at present can celebrate its 250th anniversary. Euler was the first to introduce the concept of a critical load of a structure and to define the criteria of stability in loading a rod. Suppose we have a cylindrical elastic rod with a fixed bottom end and an upper end that is free to move vertically. The length of the rod equals  $\ell$ , and the modulus of elasticity is  $E$  (Figure 5).

Now let us assume that the free end of the rod is subjected to force  $P$ . Euler showed that there is a critical force  $P_{cr}$ , such that if

$$P < P_{cr}$$

and here we bend the rod to the side with the slight force  $p$ , and after this release the force  $p$ , then the axis will return to its initial position (in other words, if the point of applying force  $P$  is slightly displaced, then the rod will also bend slightly). If  $P > P_{cr}$ , then regardless how small the initial deflection of the rod, it will not return to its initial position. Euler derived his famous formula

$$P_{cr} = \frac{\pi^2 EJ}{\ell^2},$$

where  $E$  is the Young's modulus and  $J$ --the inertia.

During World War II and in the years following it, an analysis was made on the destruction and results of detonating various metal structures. Strange phenomena were discovered such as beams which had been subjected to pressure were bent as a harmonic (Figure 6). A similar picture was observed with the effect of explosive loads on hollow containers.

These observations initiated a number of experiments to discover what would happen to a rod if the load  $P$  was  $n$ -fold greater than the critical. The experiments showed that in this case the rod would be bent in the shape of a sine curve, with the number of waves increasing with an increase of  $n$ .

The phenomenon was deciphered in 1948 by the joint efforts of A. Yu. Ishlinskiy and myself, and served as the beginning of the development of the theory of dynamic stability.

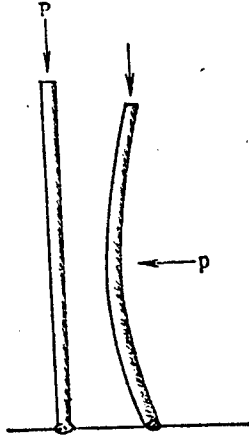

Fig. 5

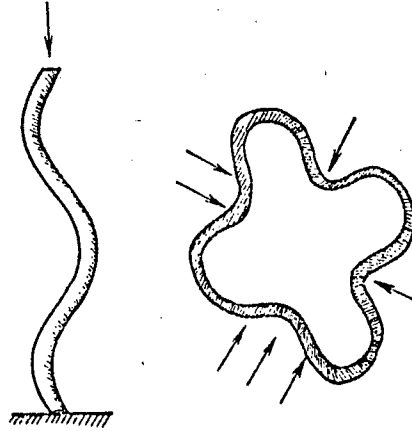

Fig. 6

It is not difficult to understand that with instantaneously applied heavy loads, the loss of stability will differ qualitatively from the instance when the load is increased slowly. If a thin and long nail must be driven into a board, a sharp strong blow is required; with a weak blow, the nail will bend in two. A qualitative explanation is almost trivial. With a small load, only the elastic, strength properties of the rod can be considered; with a great load it is necessary to consider also the inertial forces and the forces which resist the bending.

In examining the inertial forces in studying the strength of a rod, the following theorem can be proven.

If under the conditions of the Euler problem, we assume that the load is  $n$  times greater than the critical

$$P \approx nP_{cr} ,$$

then the rod will be bent according to a sine curve with  $\sqrt{n}$  bends.

It is obvious that the created theory of dynamic stability also has purely practical interest in the designing of structures with dynamic loads. Dynamic stability may also be viewed as the simplest model for the destruction of delicate systems.

Figure 7 shows the photographs of an experiment illustrating the bending of a rod with a dynamic load and its breaking into several parts. Certainly, in practice our conclusion was realized only in the probability sense, that is, in conducting a large series of experiments, the average number of breaks was close to  $\sqrt{n}$ .

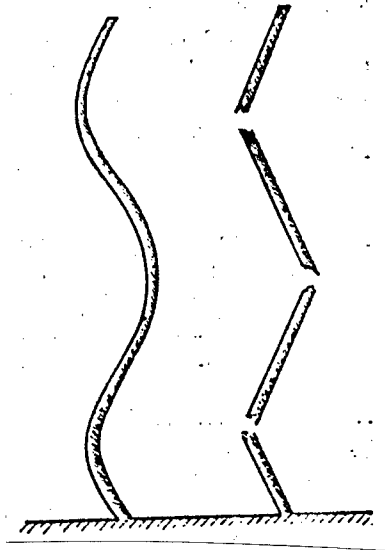

Fig. 7

It is interesting to note that an analogous result is observed with the instantaneous loading of a thin-walled pipe when it is subjected to external pressure. As is the case with the rod, there is a critical pressure  $P_{cr}$  such that if the external pressure on the pipe is less than the critical, then it is stable; if the pipe is subjected to stressing at the limits of its elasticity, then with the removing of the bending force, it will return to its previous state. If the pressure exceeds the critical, the pipe will lose its stability in the preceding sense. If the load is  $n$ -fold greater than the critical, then we will obtain a deformation with a number of waves on the order of  $\sqrt{n}$ .

The following example provides the clearest example of dynamic instability. If a thin-walled pipe with plugged ends is submerged in water, and afterwards an explosion is caused close to the bottom end, the pipe will be crumpled such that its section will be wavy with the largest

number of waves near the charge (Figure 8).

Although during the last 20 years the problem of dynamic stability has made significant headway, there still remain many unsolved problems, for example, the dynamic instability of spherical shells.

2. Laws of penetration. As long as artillery has existed, there has been a study of the laws of penetration (with a bullet or projectile) of obstacles. For hundreds of years the formula of the French artillery officer Jacobe d'Amarre has been used for the depth of penetration  $L$ :

$$L = k \frac{mv^{1+a}}{d^2},$$

where  $V$ --velocity of projectile,  $d$ --caliber,  $m$ --mass,  $k$ --numerical coefficient depending upon strength properties of projectile.

The coefficients of  $k$  and  $a$  are determined by firing. The velocity of the projectiles did not exceed 500 m per second. The ratio of the length of the projectile to its diameter did not exceed 3-4.

During World War II, for the first time a new antitank projectile, a hollow-charge shell, was used. This shell in encountering an obstacle released "wire" with a diameter of 2-3 mm and a length up to 200 mm. This wire pierced armor up to 200 mm thick. In studying these "projectiles," a number of paradoxical facts were encountered:

- 1) Where did the wire come from;
- 2) It turned out that with an increase in the velocity of the wire, the depth of penetration virtually did not change.

Instead of the above formula, we have

$$L = \ell,$$

where  $\ell$  is the length of the wire.

All the paradoxes were reproduced using a mathematical model of the phenomenon, with the steel cone of the projectile and the steel armor being viewed as an ideal rigid fluid. The problem was that with the formation of the wire and in the piercing of the armor, the strength and elasticity forces were insignificantly small in comparison with the inertial ones.

The theory was developed independently in England and in the USSR. The accepted scheme for many seemed absurd; it was strongly supported by Keldysh and Sedov who immediately saw the feasibility of the model and aided in the further work.

Within the same group of ideas, a number of experiments simulating the effect of the falling of meteorites on obstacles was carried out at the Hydrodynamics Institute Under the Siberian Division of the USSR Academy of Sciences. Blows were reproduced using an iron particle with a diameter of 1.7 mm against lead plates with varying thickness with an impact velocity from 5 to 10.5 km per second. The craters formed as a result of the impact had diameters that were 7-8-fold larger than the impact particle. At a velocity of 5-8 km per second, a certain percentage of the matter of the particle remained on the surface of the crater. With an increase in velocity, this quantity declined.

In the laboratory of Professor V. M. Titov, record high velocities were obtained with the accelerating of shot, and a new device was developed for studying the effect of the colliding of the shot with the obstacle.

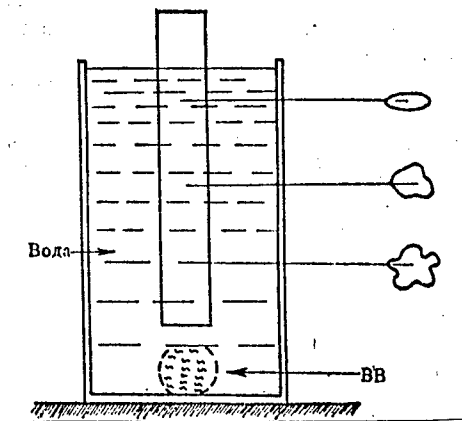

Fig. 8

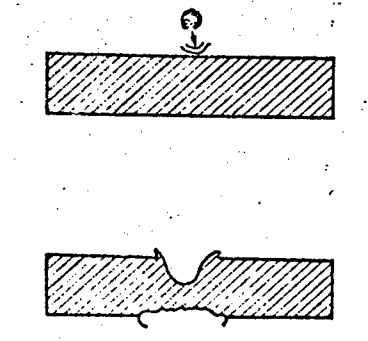

Fig. 9

Figure 9 shows photographs of a cross-section of lead plates of varying thickness after the impact. On them one can clearly see the effect of the blast wave which passed ahead of the particle, and the above-described schemes precisely consider the presence of this wave.

3. Welding by explosion. The phenomenon of the welding of metals by explosion was discovered in the hollow-charge experiments in 1944-1946 which were carried out by my co-workers. Figure 10 shows the double-layer model obtained in these experiments and formed as a result of the simultaneous compression of two cones of different metals. Here one can see the main feature characterizing the welding, that is, the formation of waves on the contact surface of the welded metals. In the same experiments, N. M. Sity obtained monolithic rings from a sheaf of copper wire, wrapping this with detonating cord.

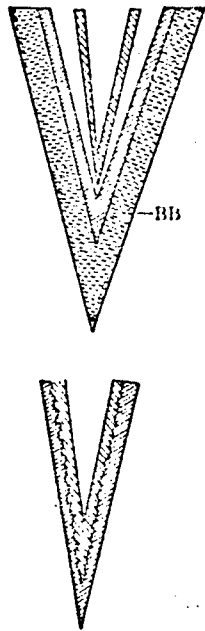

Fig. 10

After this there was a long pause in studying welding by explosion. Systematic research started in the 1960's chiefly in the USSR and the United States. Here we will give certain results belonging basically to A. A. Deribas and S. K. Godunov.

The simplest scheme. The welding of metals by an explosion can be carried out according to the scheme shown in Figure 11. The plates to be welded are placed (in the air or in a vacuum) a certain distance apart so that their planes form the angle  $\alpha$ . The bottom plate is held firmly on any support, and on the surface of the second (sometimes on top a certain inert undercoating) a layer of explosive [BB] is placed.

The igniting of the explosive is carried out at the corner at point A of Figure 11. As a result of the explosion, the ejected plate acquires a velocity on the order of several hundred meters per second.

In knowing angle  $\alpha$  and the detonation velocity, it is possible to find angle  $\gamma$  which is an important parameter of welding.

Close to the point of contact with explosion welding, as well as with the bursting of the hollow charges, such a high pressure is obtained that the strength properties of the metals become inconsequential, and in the close zone around the contact surface, the scheme for a rigid fluid can be used.

The phenomenon of wave formation with detonation welding for a long time did not have a theoretical explanation. Initially a dependence was obtained between the length of the wave and the parameters of the collision, and recently the theory has also made progress.

Along with the development of the theory and practice in creating a bimetal in the form of sheets, in the last 10 years, many results (theoretical and experimental) have been obtained in creating convoluted articles using components of various metals and nonmetals (steel, copper, lead, nickel and ceramics) using an explosion. A technology was developed for facing using the explosive method for large and small convoluted articles with special particularly resistant coverings. In this manner the turbine blades at the Krasnoyarsk hydroelectric plant were plated with stainless steel.

Many instances are also encountered when the explosive method is the only one for obtaining the corresponding articles.

In the last 5 years, great advances in this area have been obtained at the Explosive Welding Department at the Electric Welding Institute imeni E. O. Paton (Kiev). This remarkable institute-firm combines great metallurgical science with the direct introduction of its newest achievements into industry.

4. Mining and explosions. For a long time the mining industry made most extensive use of explosives in industry. A large number of experimental and theoretical works was devoted to the problem of the destruction of the given rock in an explosion. Of particular practical interest was the problem of how the charge was to be placed in the rocky ground in order to obtain pieces of rock of a certain size after the explosion. At the Mining Institute Under the Siberian Division of the USSR Academy of Sciences, interesting results have been obtained. For a large class of rocks, they have found how frequently and with what spacing the charges of explosives must be placed in the rock in order to obtain rock fragments with approximately the needed size after the explosion.

Recently a completely new approach was discovered to the problem of the fracturing of rock. The problem was posed as follows: we have an area  $D$  filled with rock, and in this area there is a distribution of stresses  $q$ . On the surface of  $D$  the explosive charge must be placed in such a manner that after the undermining the preset stresses  $q$  will be obtained. In knowing the strength of the rock and in being able to solve the "problem," we will be able to fracture the rock into pieces of a definite shape and size. A number of successful experiments was carried out, but as always, with a new approach, the work must be continued and the conditions of use and the security of this method must be more accurately determined. Very interesting results--an experiment plus mathematical models--have been obtained also for large explosions related to seismic methods for locating useful minerals.

5. An aimed explosion. The question of the aimed moving of dirt using an explosion is of great practical significance. In carrying out a number of explosive jobs (for example in building reservoirs by explosion), the problem arises of moving a certain mass of dirt in a given direction. As is known, with an ordinary underground explosion, when the free surface is

horizontal, the ejecting of the ground occurs evenly along the axis of the explosion pit or ejection. If the surface is sloping, a large portion of the dirt is ejected perpendicular to the surface. This circumstance in practice is used for intensifying the direction of the ejection. The explosion is made in two stages. Initially a small charge is set off, and this creates a new open surface with a greater incline toward the horizon than the initial one. After this the basic charge is set off and this throws the dirt in the desired direction.

One of the largest explosions of this type was made in the region of Alma-Ata (Kazakhstan), in 1967, in creating a dam on the Alma-Ata River. With two aimed explosions on the two sides of the channel, a dam was created that was 61 m high at the lowest point and 500 m wide. The volume of the dam was 2 million  $m^3$ . In 1973, this dam protected the city against a large mud flow. By analogy with previous mud flows, without this dam one-third of the city would have been buried.

The placement of charges. The just described method and similar ones, however, do not provide a complete aiming of the explosion. Around 12 years ago a fundamentally new method was proposed for an aimed explosion, and this provided a 100-percent aiming in ejecting the ground. The solving of the following problem lay at its base.

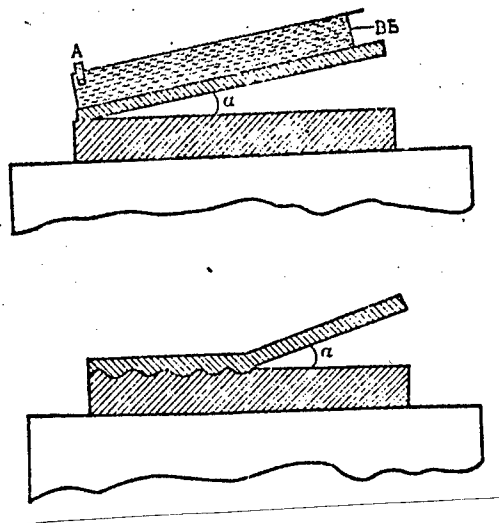

Fig. 11

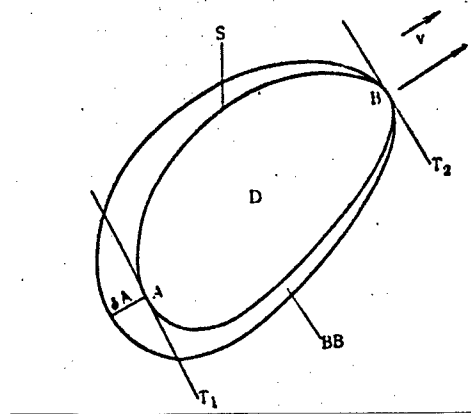

Fig. 12

Let us assume that we have a convex mass D of a rigid fluid (water, wet sand or wet clay). Can this mass be covered in such a manner by a layer of explosives that after the explosion the mass would fly in the desired direction as a solid? Let us assume (this is sufficiently established by theory and practice) that the effect of the explosion on D will be a pulse proportional at each point of the layer of the explosive. With this hypothesis for solving the problem, let us cut two depressions in relation

to the boundary of D and perpendicular to V. At the point of tangency A (Figure 12), the depth of the layer equals  $\delta$ , and at the opposite point of tangency it equals zero, and at the remaining points of the body, the thickness of the layer changes according to a linear law from zero to  $\delta$ . According to the accepted hypothesis, with the detonating of such a charge, our mass will fly as a solid in direction V at a velocity proportional to the thickness of the layer. This system has been used in a number of mining projects, as well as for creating vortical rings with a great initial velocity.

In conclusion, I would point out several other interesting problems in gas dynamics, as well as in the theory and practice of waves in a heavy fluid (seas and oceans). In gas dynamics, in the examined area of a current, there are zones where the velocities are subsonic and zones where the velocities are supersonic. In the language of a mathematical model, we have a finite problem with differential equations of the mixed type, and in relation to the one area (subsonic), we have a system of equations of the elliptical type, and in the other area (supersonic), of the hyperbolic type. The Italian mathematician Tricomi (1930) was the first to be concerned with finite problems of this type; after this, this area was greatly developed by the works of Bitsadze, Babenko, and in recent years at the Computer Center in Dorodnitsyn, where the problems were solved with the wide use of computers.

For the first time the problem of the nozzle was solved.

The area of unstable regimes is very little studied, particularly in gas dynamics. This applies above all to the phenomena in the atmosphere. With good reason many people have proposed that April 1 be declared Meteorologists Day. With the present might of science and technology, precisely instability can help to replace the "predictions" by "effect."

In concluding, I would like to point out one other major area of mechanics --gyroscopes and their numerous applications in very important problems in technology. The gyroscope is one of the control elements of sea-going vessels, airplanes and spacecraft. And here we should note the large group of scientists and engineers including Ishlinskiy and others, who have made a great contribution to the theory and practice of this large and important area of science and technology.

#### Major Science and the Problem of Scientific Personnel

The rapid growth of science and its role in the fate of mankind at present convincingly show that the development of industry, agriculture and the defense capability of the state depend upon the level of science and upon the level of the scientific personnel. At present, the special role which mathematics and physics are presently assuming is also becoming clear; on the borderline between physics and the other questions, in recent years

enormous successes have been made, and all of them would have been impossible without mathematics and its methods and electronic computers.

All of this forces us, the scientists from these specialties, to be responsible for providing the growth of science and scientific personnel in the necessary directions and scales, both in terms of quantity and quality.

The significant advances achieved in the USSR during the years of Soviet power in the area of universal secondary education and the enormous scale of higher education have brought our nation to the forefront in world science. Precisely this has been crucial for our priority in the problem of conquering outer space such as the flight around the moon, our first cosmonauts, the Mars-1 spacecraft which have already been inscribed in the history of the greatest achievements of world science and technology. Our science has also achieved significant successes in other areas. Precisely these successes and the analysis of how they were achieved and by whom must underlie the organizing of new scientific institutions and the further improvement in the training of scientific personnel. These problems are not new as the evolution in the methods of training replacements has existed over the centuries, but at present, in the age of developing nuclear power and conquering space, this problem is assuming particular significance throughout the world and thousands of articles, books and major experiments are devoted to it. Over the last 2 years, in our country scores of articles have appeared in PRAVDA and IZVESTIYA the authors of which are prominent Soviet scientists such as Academician Skryabin, Academician Kapitsa, Academician Tam, Academician Vekuo, Academician Komogorov, Academician Semenov, Academician Sobolev, Corresponding Member of the USSR Academy of Sciences A. D. Aleksandrov, and others.

These articles make very correct proposals, but unfortunately their realization has been slight. Here it is a question that the reform, as crucial as it is, will require the preparation of new textbooks and the retraining of tens and hundreds of thousands of teachers. Moreover, as experience shows, in the reorganization it is very difficult to predict all the consequences from converting to the new system, and the basic advantage of the new system can be completely nullified by unforeseen effects.

Here, in science and in its organization, something new is appearing which gives rise to the necessity of immediately commencing the reform in the training of scientific personnel, and particularly the personnel with higher skills.

Innovations in science:

1. Over the last 20 years, the quantity of important facts which science possesses has increased by 10-fold, and completely new directions have appeared with their own research methods and set of basic facts. In order to bring the graduates of the institutions of higher learning closer to the present state of science, the policy was selected (long ago) of

increasing the period of instruction and the number of classroom hours. Here the amount of material which the student had to assimilate during a week increased continuously year after year. This has led to three very harmful consequences: 1. The material has begun to be assimilated superficially and formally, 2. the absence of free time reduces creative activity, 3. the number of instructors has increased sharply. If we add to this the fact that for a long time everything has moved largely from the institutions of higher learning to the scientific research institutes of industry and the Academy, then we can conclude that the level of instruction has declined not only due to overwork, but also due to the reduction in the skills of the faculty.

2. New scientific discoveries are appearing which provide people with new opportunities for using the forces of nature. On this basis very new areas of technology are being created and are growing rapidly. Very often these discoveries and their realization in practice are on the borderline between several major areas of modern science and technology. For the rapid development of such areas, there must be cooperation among scientists from many specialties and many scientific and industrial institutes, and people are required who would be capable of achieving this unification.

The first and most vivid example of such cooperation is the solving of the problem of using nuclear power. At present, the number of such examples is constantly growing. A new type of scientist is taking shape, the organizer scientist, the scientist capable of thinking on an enormous scale. He is a person with broad erudition and who creates a plan for carrying out his ideas, a plan in which figures the solving of many problems from diverse areas of knowledge. In order to more quickly achieve the aim, for individual particularly important elements, several variations are put into operation at the same time. With the continuous observations during working time, difficulties and hopeless situations arise which lead to new problems, and in this manner bypasses must be found. Thus it is essential to combine broad knowledge in diverse areas of science and technology with a knowledge of people and a strong will.

Many well known scientists and specialists at times have been complete unsuited as the organizers of a new undertaking or as the leaders of a collective. A mistake in appointing an unsuitable leader can be a very costly one, as the scientist loses his ability to work, altercations arise in the collective, and the work is disrupted. The need for an organizer scientist at present is extremely acute, and will grow constantly in the future. When one speaks of training personnel with a higher skill, it is essential to bear such people in mind particularly. It is essential to note that precisely here we encounter the greatest contradictions between the existing forms of scientific skills and major science. The leadership of the army of scientists has titles such as "candidate," "doctor," "corresponding member," and "academician." This system has existed for centuries in most countries of the world. The practical criterion for the awarding of a degree and a title has changed very little. This is based upon personal

works in the form of voluminous tracts with descriptions of experiments and theories. As was the case 100 years ago, at present there are dissertations which are the natural conclusion of intense work, dissertations which are an important contribution to science. At the same time, dissertations are encountered the purpose of which is to obtain a degree. Such dissertations conform fully to the "form" established by the VAK [High Degree Commission], but in essence they are scientific-appearing garb dressed up in mathematical signs for a foreign idea or a foreign invention. Even worse, with these forms of awarding a degree, no place is given to the organizers of science or to the creators of new technology. It is no accident that our best known designers have become academicians without even being candidates of sciences. In recent years, the VAK has been able to award the academic degree of "doctor" to designers known throughout the USSR, without the procedure of submitting a voluminous work. Unfortunately, there still are expert commissions of the VAK which even now have not grasped the spirit of the times and have delayed very clear questions for two and more years.

3. Science at present and particularly science tomorrow gives rise and will give rise to "deviations." We still pay very little attention and disregard these deviations, in spite of the fact that at present they are of great significance. We will endeavor to explain just what the "deviations from science" mean. For solving a specific problem in science or technology, there must be, so to speak, the art of creating and studying the patterns of a certain phenomenon. An institute is designed and after this, a structure is put up with the help of industry. During the period of designing and construction, the personnel is recruited, and students are selected and trained. The structure is complete and the long-awaited experiment commences. For 2, 3 or 5 years, intensive work is carried out, and important results and discoveries are obtained which are used in the adjacent areas of science and technology. The intensive training and numerical growth of the personnel continue. However, suddenly a sharp decline in the product commences, as the structure is already out of date, and refined, uninteresting problems appear to "clarify" the already known things, and the institution begins to mark time. At times we encounter more unpleasant situations where by the time the facility is in operation the problem has lost its urgency or an alternative path is found by which the problem can be solved more quickly and more completely. In the same manner that a plant which has not kept pace with the development of technology becomes a brake on the introduction of innovations, so the large institutions which are marking time divert forces and means from the basic directions. The "senior scientific research institutes" are more dangerous than the "senior plants," since a "senior plant" which produces an obsolete product must die, but a "senior institute" can live for decades.

In order to avoid the building of a scientific enterprise with no future and to rapidly reorient the collective which is marking time to actually timely subjects, it is essential to strengthen the role of scientific public opinion.

In accord with what has been stated above, I would like to formulate certain conditions which must be carried out without fail in the further reform in the process of training scientific personnel:

1. There must be a much stronger involvement of the scientists who are directing the science of today in the process of educating and training the youth. The organizing of lectures and seminars must be more widely used in the laboratories and scientific research institutes. The students must be involved as early as possible in the work of the scientific research institutes.

2. In the cities where there are scientific research institutes in the area of physicomathematical sciences and a university (subVUZes), scientists from the scientific research institutes of all ranks must be more widely involved in the teaching.

3. The independent exercises of the students must be sharply strengthened in the curriculums and syllabuses of the faculties in the physicomathematical and chemical area, since here it is much more important to learn how to think, to invent, to carry out experiments, to learn how to devote all ones energies to solving a difficult problem, than it is to learn formally, to conduct experiments and then forget them. These provisions which are absolutely clear to us, the pedagogues, have very often not been taken into account. There are very few people who are capable of listening closely to scientific lectures for more than 4 hours; even now there are days when a student must sit for 6 or even 8 hours running. And everyone, even someone who is little acquainted with construction problems, knows that you must not paint fresh plaster because it will be ruined. The process of acquiring knowledge is much more complex than the completing of rooms, and requires a definite technology. To listen to three serious scientific lectures without a break is as bad as eating three meals one after another.

4. It is essential to sharply increase the number of direct contacts between the scientists (both older and young) and the students. A lecture is undoubtedly of use, but an ordinary conversation on a scientific subject would be even more useful between several persons with the raising of free questions and by discussion. The overloading of scientists with lectures leads to a situation where such conversations are very rarely held and as a rule even the examinations are given by assistants, while the professors have very little contact with the young people and do not know their audience.

5. It is essential to further raise the work of admitting the students to the institutions of higher learning. In the examinations which are given (usually by an assistant) it is difficult to ascertain whether the candidate shows true interest in the given specialty. From personal experience, I know instances when, for example, of the students admitted to the Mathematics Faculty of the university, more than one-half did not have

serious mathematical abilities. The selection is impeded by the fact that the level of training in the periphery of the nation is lower than that in the capital. We lose many really gifted people. We must seriously condemn the practice of admitting to institutions of higher learning clearly poor students (in the subjects of the basic specialty of an institution of higher learning) merely for the sake of fulfilling the admissions plan. We also must not fear expelling from an institution of higher learning the young people who find it difficult to handle the educational process for the basic subjects. The retaining of students who receive twos is harmful for the nation. And this is also harmful for the student, since as a rule the low grade is due primarily to the fact that the student has selected his specialty wrongly. And the sooner he understands this, the sooner it will be better for him. It would be possible to give many examples of very prominent scientists who in their youth began their education in one specialty and were considered dunces, and after they had changed their specialty, found full recognition of their talent.

Now I would like to try to formulate several proposals relating to the training of personnel and which in my view are obvious. I will begin with several proposals related to secondary education.

1. In all of our major cities, it is essential to introduce the Moscow experience of providing education in special schools for physics and mathematics. For this, an essential condition is the involving of a broader group of workers from the universities and subVUZes in the work of the schools, as well as organize production training for the students in the scientific research institutes. Naturally such schools must admit only those who have an active and real interest in the physicomathematical sciences.

2. The development of the physicomathematical schools provides an opportunity to sharply raise the level of the persons being admitted to the universities and subVUZes. However, with this situation inevitably there will be a rise in the unfavorable conditions for the children in the periphery of the nation, particularly in the countryside. For this reason, in the major scientific centers it is also essential to set up physicomathematical boarding schools. Here, admission to these schools must be through correspondence and regular competitions which encompass all the schools of the given oblast or the nation. Such competitions were held in the spring of this year by the Siberian Division of the USSR Academy of Sciences. About 70 scientific workers, mathematicians and physicists visited all the oblasts and krays of Siberia and the Far East. Interestingly, many truly talented children were discovered in the towns, at construction sites, worker settlements and in the most remost kolkhozes and sovkhoses. Those completing the school will partially continue their education in the universities, while a part of them will be fully prepared for work in the laboratories of scientific research institutes and plants.

3. It is essential to reduce the period of instruction in the universities to 4 years by an overall reduction in the curriculums by 30-40 percent, with the complete exclusion of the required study of foreign languages (requirements should be increased for the foreign language exam for admission). The time which will remain free for the instructors and students should be used for independent studies and stricter control. A certain portion of the graduates (up to 50 percent) who during the period of instruction have shown particular abilities and capacity should continue their studies for another 2 years as graduate students, in working under an individual program.

A large portion of these proposals may seem paradoxical, but all my 40-year experience in institutions of higher learning and many scientific research institutes has shown that these measures will be of great benefit.

I also feel that it is essential to make the proposal again to transfer Moscow, Leningrad and Novosibirsk universities to the USSR Academy of Sciences.

In conclusion, I would like to stress that I am confident that the further involvement of ever broader masses in science and the use of scientists for their education will make it possible for us to take the next step to carry out the decisions of the 24th Party Congress, and to bring our nation into leading positions in the world for all the basic scientific problems.

#### A Model of the Motion of Fish and Grass Snakes<sup>1</sup>

Numerous studies have been carried out in various areas of mechanics and biology in order to discover how various types of fish move. It is a question of theoretical and experimental work in which the most advanced modern methods have been used.

In the present paper, I intend to describe a model for the motion of a body in a rigid fluid medium.

How does this body convert its potential energy into kinetic energy?

Certain results of this sort have been given in papers and articles.<sup>2</sup>

---

<sup>1</sup>The scientific paper was given before the Academy of Sciences, Paris, 26 June 1972.

<sup>2</sup>M. Keldysh and M. Lavrent'yev, "On the Theory of a Vibrating Wing," "Tekhnicheski Belezhki" [Technical Notes], ZAGI, Moscow, 1935; M. A. Lavrent'yev and M. M. Lavrent'yev, "On a Method for Transforming Inner Tensions into Motion," PMTOP, No 4, Moscow, 1962; V. Kuznetsov, B. Logovizov and Ya. Cher, ARKH. RATS. MEKH. ANAL., 25, 1967, p 5; Ya. Cher, "Vurkhu Problema za Dvizhenieto na Smokovete i Ribite" [On the Problem of the Motion of Snakes and Fishes; Certain Problems of Mathematics and Mechanics], Nauka, Leningrad, 1970.

In order to construct a model of the motion in question, certain preliminary premises are needed:

1. Let us take a channel with solid walls the cross-section of which is a circle with a certain radius (or a rectangle with definite sides). We assume that the axis of the channel is a flat line with a variable curve (for example, sine). Now let us assume that an elastic body (a snake) has been placed in the channel, and its section corresponds to this channel. We also assume that there is no friction on the surface of the channel and on the surface of the snake. Let us inquire whether the immobile snake can attain speed, in endeavoring to bend more or less the various parts of its body. The answer is almost apparent: if the snake intends to move in one direction, each part of its body must make such efforts, as a consequence of which the movement in the selected direction reduces its potential energy.

This becomes particularly clear if the axis of the channel possesses a curve which changes according to the linear law:

$$K = K_0 - as, \quad 0 < s < \frac{K_0}{a} = \ell, \quad (1)$$

where,  $s$  is the length of the arc of the axis of the channel between the maximum point of the curve and an arbitrarily selected point of the axis. Now let us assume that we have a straight elastic cylinder with length  $\ell$ , the base of which is a circle with a diameter equal to the diameter of the channel. We place the cylinder in the channel and let us leave it free. If the cylinder is slid in the direction in which its curve is reduced, then the potential energy of the cylinder also is reduced. This velocity  $v$  of the cylinder at the moment of leaving the channel will be equal to

$$v = \sqrt{\frac{2E}{m}}, \quad (2)$$

where  $E$  is the potential energy of the curved cylinder, and  $m$ —its mass or weight.

These conclusions are not changed if the cross-section is a rectangle.

2. This is the second problem of hydrodynamics. Let us assume in an absolutely rigid fluid, a cylindrical surface  $D$  with parallel generating lines on axis  $Z$ , its base  $C$  in the plane  $Z=0$  is less in relation to its height. It is a question of calculating the required energy (derived from wall  $D$ ) for transforming  $D$  into  $\bar{D}$  which has the same height and the same volume.

Let us construct a class of areas  $D\tau$ , with base  $C\tau$  according to a method whereby  $D$  is transformed into  $\bar{D}$ , when  $\tau$  varies from 0 to  $\tau_0$ . With a sufficiently large height, we can solve the problem of the plane. Let us

designate by  $\psi(x, y)$  the potential of the velocity field of the fluid produced by the movement  $C\tau$ . The function  $\Phi$  is a harmonic function, for which we recognize the values of  $\partial\psi/\partial n$  to  $C$ . According to the well known methods, we obtain  $\Phi$  and hence the required energy. By this calculation it is easy to deduce that the designated energy moves toward zero with the rate of deformation of  $D$  into  $D$ .

3. Using the above-given argument, the following theorem can be proved. Let us examine a cylindrical surface in an absolutely rigid fluid. Let us cause the motion of this surface. This motion causes tension in the fluid. Then the question is posed: What can be the rate of distance [interval]  $r \gg 1$  from the surface, if the speed transmitted to the surface is on a magnitude of  $1$ ? In this instance, the speed which we are examining is on a magnitude of  $1/r^2$ .

4. Now let us turn to the subject of the present paper. Let us examine the movement in a heavily viscous fluid of a cylindrical plate  $P$  with a length  $\ell$ , a thickness  $\delta$  and a width  $l$ ;  $\delta \ll l \ll \ell$ . We assume that the edges of the plate are finite curves, to keep finite velocities of the fluid; in addition we will assume that friction along the surface of  $P$  does not exist.

Let us assume that in the plate (fish) tensions can be established which deform it, leaving it always cylindrical.

Let us assume that at the initial moment, the base of the plate possesses a certain curve  $K(1)$ . After this, the plate (fish) applies to the fluid forces which are proportional to  $K$ . These tensions are retained until the moment at which the plate becomes flat (level). According to the premises given above in 1-3, our plate accelerates in the direction in which  $K$  is nullified. Under the given conditions, the influence of the movement of the fluid will be less, and the rate of the fluid will decline as  $1/r^2$ , where  $r$  is the distance to the plate. Consequently, we can assume that our plate will move in a rigid fluid at a constant rate. Now let us assume that there is a force which reduces the speed of the plate to zero. According to Point 2, the plate after this can be deformed under the influence of internal tensions, remaining in place.

The cycle which we have just described transforms almost completely, with a fluid without vortices, the internal energy of the plate (or the fish) into kinetic energy of the same plate (or fish) moving through the fluid parallel to it.

The described scheme can be developed in various directions.

10272  
CSO: 2200

## SCIENTISTS AND SCIENTIFIC ORGANIZATIONS

### SIBERIAN DEPARTMENT OF USSR ACADEMY OF SCIENCES

Moscow SOVETSKAYA ROSSIYA in Russian 21 Jan 77 p 2

[Article by G.I. Marchuk, candidate-member of the Communist Party of the Soviet Union, academician, chairman of the Siberian Department of the USSR Academy of Sciences: "An Inexhaustible Wellspring of Progress"]

[Text] Almost 20 years ago, through the decision of the party and the government, the Siberian Department of the USSR Academy of Sciences was established: eminent scientists of our country, together with their collectives, arrived at this northern region and laid the foundation for one of the major scientific centers--the Academic City at Novosibirsk.

The communist scientists, having devoted many years to the formation and development of the new regional department of the Academy of Sciences, displayed great civic responsibility for the country and the people. Today there is a powerful research base in Siberia, with scientific centers not only at Novosibirsk, but also in Irkutsk, Yakutsk, Ulan-Ude, Krasnoyarsk and Tomsk. The action, of great state significance, undertaken by the party and the government played an exceptional role in the development of Siberia's science and productive forces. Its main result, however, is the system of training highly skilled personnel that has been formed here and has made it possible to establish a number of large scientific schools, with great prestige both in our country and abroad. These are the schools of mathematics, mechanics, physics, chemistry, geology, biology, genetics and social sciences. In a word, all the principal fundamental directions of science have not only been developed in Siberia, but have also been formed into major, actively working collectives.

The establishing of the Siberian Department of the USSR Academy of Sciences is of course a multi-plan problem, but the main emphasis in it is the formation of the builder of communist society. It is not enough merely to be a good scientist. The 25th Party Congress particularly stressed the importance of the social aspects in the development of the personality. It is this that is the hard core of personnel formation at the Siberian department. We have a large detachment of first-class young scientists, many of whom occupied important positions in science and public life. This was furthered by the

attentive work done by the party and komsomol organizations in drawing young people into an active, interesting life and provided the correct direction for the development of their intellect.

A large role in the civic formation of the young scientists was naturally played by the vast task imposed by the party and the government on the Siberian department: developing the extremely rich region. Our motherland requires the intensive development of Siberia: it is not by chance that the 25th Party Congress determined that the rates of its development in the Tenth Five-Year Plan should be 50 percent higher than in the Ninth Five-Year Plan. This rate can be realized only with the aid of scientific ideas.

Siberia is developing through the establishing of large territorial industrial complexes, in which are concentrated power resources, mineral raw materials and refineries.

We have already witnessed the rapid development of petroleum and gas extraction in Western Siberia and the construction of the Bratsk-Ust'-Ilimsk Territorial Industrial Complex and the Krasnoyarsk Complex, which is now being converted to the Angaro-Yeniseysk Complex, expanding the sphere of its operation and affecting the development of Siberia, and the Sayano-Shushenskiy and Kansko-Achinsk complexes are springing up. It is impossible to think of Siberia now without conceiving of the broad perspectives opened by the Baykal-Amur Trunkline, which provided access to the extremely rich raw material resources of coal, copper, polymetallic and other minerals. In this five-year plan a substantial role will be played in Siberia's economic system by the Yuzhno-Yakutsk Territorial Industrial Complex. In a word, Siberia is beginning to reveal its storehouses. In order to use them effectively, there must be comprehensive programs which take maximum consideration of the various aspects of the national economic plan and coordinate them with the over-all state plan for the development of our country's economic system.

The growth of Siberia's productive forces on the basis of the fundamental directions of the sciences, the discovery of new ways in the technological development and processing of mineral raw material and the creating of favorable conditions for the life of the people in this severe region -- this is the source of enthusiasm of the scientists of the Siberian department. We value the great faith that has been shown us by the people--to be in the front line of the struggle for scientific-technical progress and actively participate in the development of our country's economics. This faith engenders a profound responsibility for the cause entrusted to them.

While working today, we think about what will happen to Siberia in 20, or in 50 years. It is absolutely certain: in these next 50 years, Siberia will constantly be the center of attention of the Soviet man. Here will spring up new cities, new industrial complexes, each of which should be and will be better than the preceding ones--after all, they will absorb all the experience accumulated in the development of Siberia! The vast region will be covered by a network of communications, railroads, and highways, and oil

and gas pipelines--there will be more active development of its riches, and in this advancing dynamism the problem of nature conservation and environmental protection will be increasingly essential.

The new complexes, which are not yet on the map, but which will certainly be built up and have their say, should already be planned so as to have the minimal effect on the environment. Ways of regenerating and augmenting the natural resources should be incorporated in their plans.

The true citizen-scientist always thinks of the results of his ideas and developments on the life of society. This is equally true of those who are involved in profoundly theoretical questions, from which the yield will come after years and even decades, and scientists afforded the possibility of devoting time and attention to working out today's problems. The development of fundamental research is particularly important for the Academy of Sciences, because the profound theoretical ideas in principle are not rapidly put into effect, but they are the ones that have the most revolutionizing effect on society as a whole, on the development of the productive forces and on scientific-technical progress.

In reality, when scientists discovered the structure of the atomic nucleus and saw its innermost depths, no one yet thought that this would be the basis of creating one of the most important fields of technology today--nuclear power. Even today, society's well-being depends substantially on its growth rate. Algebraists 100 years ago "groped" for extremely simple binary arithmetic, which resulted in the possibility of designing electronic computers. This computer engineering is now playing a decisive role in the administration of the socialist society. Many examples of this may be given. Revolutionizing ideas are also appearing today. These are laser techniques, holography, genetics--in a word, we are participants in and witnesses of the rapid development of fundamental sciences. Scientists' duty lies in realizing the possibilities established by science for society's use.

From the very beginning of its development, the Siberian department paid great attention to the processes of linking science and the national economy. Our first experiments with this link with individual enterprises have now resulted in a number of general approaches to assimilation, which may be briefly formulated as the principle of an "outlet to the sector." We are trying to follow and shape the chain, generally difficult, but necessary, that would take an idea realized at one enterprise, for distribution to analogous enterprises throughout the sector, and in the future--to a number of sectors in the national economy. Only in this case does science appear as a direct productive force.

We implemented the "outlet to the sector" in solving 40 problems. One of these is Tashtagol, where a mine with a high degree of automation is in operation in the mining industry; blast welding--designing multilayer blanks of metal for various sectors of the national economy; powerful

catalysts for the production of sulfuric acid--the main component in mineral fertilizers; automated control systems, widely used in Siberian enterprises.

I would like to emphasize one more idea, which must not be forgotten: not only does the national economy need science, but science itself needs links with life, production and the national economy, for the contact of scientists with production workers, and the joint discussion of the most pressing problems of engineering and technology often make it possible for the scientists to see the appearance of new problems which, if comprehended in time, will provide the beginning of new theoretical research.

The problem of selecting the most promising directions is a very complex process. Primarily for the sake of this selection, a review of the fundamental research carried out in its institutes is now being made in the Siberian Department of the USSR Academy of Sciences. I will speak of only some of them that will give an idea of their goal and urgency.

The Institute of Atmospheric Optics, which is located in Tomsk, is doing comprehensive research on atmospheric optical phenomena. In particular, a work cycle on "Laser Sounding of Atmospheric Aerosols" was recently completed. It was the result not only of scientific interest, but also of practical need: on the one hand, the scale of man's influence on the environment is constantly increasing--new areas are being developed and there is an increase in the number of industrial wastes which are discharged into the atmosphere in the form of gases and aerosols. On the other hand--the development of high-speed aviation requires a reliable prediction of the state of the atmosphere. The existing methods of measuring atmospheric parameters are not satisfactory from the standpoint of the efficiency of obtaining data and their completeness. It was necessary to develop long-distance methods, new in principle, for atmospheric diagnosis.

The institute designed a laser locator to determine atmospheric pollution. The short pulse of the laser radiation penetrates the sky with tremendous rapidity. There it reacts with atmospheric gases, aerosols and turbulent irregularities. Part of the radiation, like an echo, returns--this reflected signal is recorded, and an electronic computer requires only seconds to process the incoming information.

The laser device makes all the measurements almost instantaneously. The locator makes it possible to evaluate the concentration of impurities and to study in detail the structure of the pollution at different altitudes--from one meter to dozens of kilometers.

The Institute of Inorganic Chemistry of the Siberian Department is carrying out a large cycle of research in one of its scientific directions--extraction, that is separating and obtaining pure substances.

New methods are being worked out and extractor units are being designed. A number of pure metals, critically needed by today's industry have already been obtained by means of them. The extremely precise study of the structure of the molecules has made it possible to find the specific extractants, which also made it possible to extract substances with high purity.

If one considers that the extraction processes are continuous and lend themselves easily to automation, it is not hard to imagine the amount of saving in capital investments and current expenditures with extraction purification....

The CPSU Central Committee October (1976) Plenum re-emphasized the need to intensify attention to problems of scientific-technical progress. After all, it is unfortunate that many examples may be given of innovations either not being assimilated at all, or at inadmissibly slow rates. Today the department's institutes have in their "portfolio" dozens of completed works, including those on ministry assignments which have not been introduced for a number of years. This is inadmissible wastefulness, in no way justified. It is not without cause, however, and one of the most serious causes is the poor economic motivation of the enterprises to acquire new equipment. We have essentially shown little concern so far for problems of the efficiency of assimilation and have only a poor knowledge of what an enterprise or a sector gains from some specific scientific development.

The time has come to give clear, concrete definition to the economic indicators connected with assimilation. Especially, since we have all the potentials for this--strong economic institutes, and close connections with major enterprises. An analysis is also awaited of such an important problem as the effectiveness of comprehensive scientific programs. The results of this work will reveal hitherto unused resources, which our scientific collectives have at their disposal and which must be put into operation.

The 25th CPSU Congress posed the Academy of Sciences with a new, strategic task. We all well remember the words of Leonid Il'ich Brezhnev: "The Party evaluates highly the work of the academy and will augment its role as the center of theoretical research, the coordinator of all the scientific work in the country."

This means that the USSR Academy of Sciences and its component--the Siberian Department--are in a new stage. There must be a reinforcement and expansion of the ties between the academy and the three major detachments of the country's scientific army: the sectorial academies, VUZ science and the sectorial institutes, laboratories and design bureaus.

This is a very complex and crucial task, and requires profound study. It must not be solved in the form of an order, at one stroke. Just a few statistical data can give an idea of the scale of the work: In the USSR there are over 5,000 scientific research institutes, 40,000 planning and design bureaus and 850 institutions of higher education.

A very small proportion of all the country's scientific personnel is employed in the system of the USSR Academy of Sciences--approximately 7.5 percent. By means of the structure and forms of research that have developed, however, the professional qualifications of the workers at the academic institutions in the sphere of fundamental sciences are as a rule high. There are five times more scientific workers concentrated in the country's VUZ's than in the academy's system; these are primarily faculty associates. Since one cannot be a good teacher without being a researcher, most of them are engaged in scientific work. The VUZ teachers have to their credit tremendous experience in training personnel and in scientific research--it must be used to solve the major theoretical and applied problems.

Finally, almost half of the country's scientific workers are concentrated in the sectorial institutes, laboratories, planning and design departments and bureaus, which should also reach the sectors of the national economy with their fundamental developments.

All the conditions for cooperation in academic science are present in Siberia. Here, in addition to the Siberian Department of the USSR Academy of Sciences, the Siberian Department of the Academy of Agricultural Sciences and the Siberian branch of the Academy of Medical Sciences are developing their operations. The time has now come to coordinate the efforts of all three of our academies on the major problems.

The next stage is the coordination of scientific research work with Siberia's VUZ's.

The successful implementation of coordination will make it possible for us to pose the problem, in the next five years, of designing a sufficiently thorough comprehensive program of scientific research, carried out on Siberian territory.

We are coming to the glorious 60th anniversary of the Great October Revolution. International recognition of the October Revolution is well known, but each time, in looking back and comprehending the perspectives of the country's development, we note the remarkable achievements of mankind--Soviet power--which has made it possible for our people, including the scientific workers, to reveal their forces and abilities to develop communist society. In this tremendous creative process, the creation of the Siberian Department of the USSR Academy of Sciences is one of the fragments of our life, one of the great experiments implemented by the party and the government on the basis of the potential accumulated by the academy in the development of science in our country and its role in the building of communism.

12151  
CSO: 1870

SCIENTISTS AND SCIENTIFIC ORGANIZATIONS

SCIENTIFIC, TECHNICAL ENTRIES FOR GEORGIAN SSR STATE PRIZE

Tbilisi ZARYA VOSTOKA in Russian 5 Jan 77 p 3

[Article: "From the Committee on State Prizes of the Georgian SSR; in the Area of Science and Technology attached to the Council of Ministers of the Georgian SSR"]

[Text] The Committee on State Prizes of the Georgian SSR in the Area of Science and Technology, attached to the Council of Ministers of the Georgian SSR reports that the following works have been accepted for competition for the 1977 Georgian SSR State Prize:

1. Balavadze, B. K. (director), Tvaltvadze, G. K., Ioseliani, M. S., Kartvelishvili, K. M., Mindeli, P. Sh., Murusidze, G. Ya., Shengelaya, G. Sh., Series of works: "The Results of Gravimetric and Seismic Prospecting Research to Study the Structure of the Earth's Crust in Georgia and Adjoining Oblasts," 1955-1975.

Submitted by the Institute of Geophysics of the AS of the Georgian SSR.

2. Beritashvili, I. S., "Memory of Vertebrates, Its Characteristics and Origin" (Monograph, NAUKA, Moscow, 1974).

Submitted by the Institute of Physiology of the Georgian SSR AS.

3. Buishvili, L. L., Khutsishvili, G. R., Series of works: "Relaxation and Dynamic Polarization of Nuclei and the Saturation of the Magnetic Resonance in Solid Bodies" 1954-1975 (29 articles).

Submitted by the Order of the Red Banner Institute of Physics of the Georgian SSR AS.

4. Gogebashvili, N. V., Series of works on tuberculosis immunology, 1965-1975.

Submitted by the republic's Scientific-Research Institute of Tuberculosis of the Georgian SSR Ministry of Health.

5. Gotsiridze, R. S., "The Forest and its Surroundings" (1971), "The Growth and Development of the Coniferous Forest" (1974), "The Beginning of Life in the Plant" (1976), "Some Questions of Biogeocoenology in Mountain Forests" (1969). (Monograph, SABCHOTA SAKARTVELO).

Submitted by the Gurdzhaanskoye Mechanized Forestry Enterprise of the State Forestry Committee of the Georgian SSR.

6. Kakhiani, S. N. (director), Kakhiani, Z. N., Asatiani, D. L., Series of works on plastic morphology and on the morphology of the peripheral nervous system, 1961-1975.

Submitted by the Tbilisi State Institute for Physician Qualification of the USSR Ministry of Health.

7. Lordkipanidze, O. D., Series of works: "Concerning the Archeological Monuments of Vani" (1971-1975) (two monographs and 14 articles).

Submitted by the Institute of History, Archeology and Ethnography imeni I. A. Dzhavakhishvili of the Georgian SSR AS and by the Archeological Committee of the Georgian SSR AS.

8. Natmeladze, M. V., "The History of the Working Class of Soviet Georgia (1921-1932)," "The History of the Working Class of Soviet Georgia (1933-1945)." (Monograph in two volumes, METSNIYEREB, 1970 and 1975).

Submitted by the Institute of History, Archeology and Ethnography imeni I. A. Dzhavakhishvili of the Georgian SSR AS.

9. Pipiya, I. K. (director), Teliya, A. V., Series of works: "Problems in Stomach Pathology", 1956-1975.

Submitted by the Ministry of Health of the Georgian SSR.

10. Sakvarelidze, I. I., Gedevanishvili, L. D. (directors), Aglamazov, V. A., Robakidze, Z. P., Khazaradze, N. G., Series of works: "Concerning the Mu-onic Components of Cosmic Rays," 1966-1976.

Submitted by the Tbilisi Order of the Labor Red Banner State University of the Ministry of Higher and Secondary Specialized Education of the Georgian SSR.

11. Khechinashvili, S. N., (director), Kevanishvili, Z. Sh., Kadzhaya, O. A., Khachidze, O. A., Afonchenko, V. S., Series of works: "The Study of Stimulated Hearing Potential in Man and the Elaboration of a Methodology for Determining the Hearing Function According to the Recording of these Potentials," 1971-1976.

Submitted by the Tbilisi State Institute for Physician Qualification of the USSR Ministry of Health.

12. Tsereteli, S. B., "Dialectic Logic" (Monograph, METsNIYEREB, 1965).

Submitted by the Institute of Philosophy of the Georgian SSR AS.

13. Tsomaya, V. Sh. (director), Apkhazava, I. S., Drobyshev, O. A., Baïndurashvili, D. A., Nikolaishvili, O. T., Chikobava, D. P., Khmaladze, G. N., "Resources in USSR Surface Waters," "A Hydrographic Description of Rivers, Lakes and Reservoirs. Volume 9. Zakavkaz'ye and Dagestan. Issue 1 -- Western Zakavkaz'ye." (Monograph, GIDROMETEORIZDAT, Leningrad, 1974).

Submitted by the Administration of the Hydrometeorological Service of the Georgian SSR of the Main Administration of the Hydrometeorological Service of the USSR Council of Ministers.

14. Chirakadze, G. I., Tsutskiridze, Ya. A., Sukhishvili, E. V., Gavasheli, Sh. G., Papinashvili, L. K., Khvichiya, M. S., "Climate and the Climactic Resources of Georgia," (Monograph, GIDROMETEORIZDAT, Leningrad, 1971).

Submitted by the Zakavkazskiy Scientific-Research Hydrometeorological Institute of the Main Administration of the Hydrometeorological Service of the USSR Council of Ministers.

15. Yashvili, N. S. "The Land Fund of the Georgian SSR" 1961-1975. (Monograph in two volumes, published by the Tbilisi State University).

Submitted by the Tbilisi Order of the Labor Red Banner State University of the Ministry of Higher and Secondary Specialized Education of Georgian SSR.

16. Andrianov, K. A., Topchiashvili, M. I., Tkhinvaleli, G. Kh., "The Utilization of Polymer Materials in Water Pipes," 1964-1976.

Submitted by the Georgian Scientific-Research Institute for Energy and Hydrotechnical Structures (GruzNIEGS) of Glavminproyekt [Main administration for planning] of the Ministry of Energy and Electrification of the USSR.

17. Apridonidze, L. I. (director), Gvindzhiliya, V. F., Vardishvili, A. G., Kurashvili, Sh. I., Bezhashvili, D. A., Arutsev, A. G., Tkemaladze, N. M. "The Elaboration and Introduction within the Coal Industry of the Georgian SSR of a Method for Narrow Excavation of Coal with Combines, Primarily Under the Complex Conditions of Beds in Sloping and Inclined Strata," 1961-1969.

Submitted by Mine Number 6 of the Tkvarcheli Coal Production Association of the Gruzugol' Combinat, Ministry of the Coal Industry of the USSR.

18. Arsenishvili, A. Yu., Gvetadze, R. G., Gendzekhadze, T. L., Lanchava, M. D., Tavadze, F. N., Tskitishvili, A. A., Chubinidze, T. A., "Increased Production Effectiveness and Improvements in the Quality of Malleable Cast

Iron By Elaborating Scientifically-Based Regiments for Thermo-Time Treatment and Equipment for Metal Modification With a New Complex Type KMKAM Alloy (Silicon - Manganese - Calcium - Aluminum - Magnesium), Introduced at the Kutaiskiy Automobile Plant imeni G. K. Ordzhonikidze" 1970-1975.

Submitted by the Institute of Metallurgy imeni 50-Letiya SSSR of the Georgian SSR AS.

19. Buadze, A. I., Chivadze, Z. D., Dzhavauri, T. G., Zgudadze, G. P., Gudavadze, G. G., Nonikov, N. G., Karibov, S. I., "Research, Development and Introduction of the EK-14 Coke-Dampening Electric Locomotive" 1971-1975.

Submitted by the Tbilisi Electric Locomotive Construction Plant imeni V. I. Lenin.

20. Vashakidze, A. M., Rakovenko, P. V., Akhvlediani, V. Ya., Vashakidze, A. A., "The Development and Introduction of a Complex of Radiotelephony Communications and Stub Poles for Effective Communications on Highways in the Georgian SSR and Krasnodarskiy Kray of the RSFSR," 1967-1976.

Submitted by the Operational-Technical Administration of the USSR Ministry of Internal Affairs.

21. Gvakhariya, V. V. (director), Makhatadze, V. S., "The Elaboration and Introduction into Production of Concentrated Doses of Manganese," 1969-1975.

Submitted by the Order of Lenin Chiaturmagranets Ore Mining Combinat of the Soyuzfud All-Union Industrial Association, USSR Ministry of Ferrous Metallurgy.

22. Kozmanashvili, A. G., (director), Gelashvili, L. A., Kharatishvili, G. Z., Kvirikashvili, D. N., Petashvili, T. S., Moskalenko, A. M., "The Utilization of New Types of Raw Materials for the Production of Mixed Fodder," 1970-1975.

Submitted by the Georgian affiliate of the All-Union Scientific-Research Institute for the Mixed Fodder Industry, USSR Ministry of Procurement.

23. Kuchava, G. D., Akhvlediani, N. V., Yergakov, M. L., Khonelidze, Sh. L., Metreveli, V. I., Chkholariya, N. B., "Research, Elaboration and Introduction of Progressive Technology, Technical Resources and Grafting-Hothouse Complexes for the Production of Grafted Grape Material," 1961-1976.

Submitted by the Georgian Scientific-Research Institute of Mechanization and Electrification of Agriculture imeni K. M. Amiradzhibi and the Scientific-Research Institute of Horticulture, Viticulture and Viniculture, Ministry of Agriculture of the Georgian SSR.

24. Mindeli, E. O. Series of works: "The Destruction of Mineral Rock by Blasting" (Nine monographs, 22 inventions, 1955-1975).

Submitted by the Institute of Mining Mechanics imeni G. A. Tsulukidze, Georgian SSR AS.

25. Papava, G. I. (director), Papava, V. G., "The Elaboration and Development of Technical Resources for the Complex Mechanization of Grapevine Grafting Processes, the Study of Technological Processes and their Introduction into Production," 1956-1972.

Submitted by the Scientific-Research Institute of Horticulture, Viticulture and Viniculture of the Georgian SSR Ministry of Agriculture.

26. Suladze, O. N. (director), Kakheladze, K. G., Tkhelidze, R. A., Mindeli, M. Sh., Akhobadze, A. A., Dzaganiya, T. B., Tsereteli, P. A., "The Development of the Angstrom Automatic System," 1973-1975.

Submitted by the Planning Construction Institute of Automatization of Production Processes in Industry (Avtomatprom PKI), Soyuzpromavtomatika, of the Ministry of Instrument-Making, Automation Equipment and Control Systems.

27. Yakobashvili, S. B., "Surface Features of Welding Flux and Slag," (Monograph, TEKHNKA, Kiev, 1970).

Submitted by the Georgian Order of the Labor Red Banner Polytechnic Institute imeni V. I. Lenin, Ministry of Higher and Secondary Specialized Education of the Georgian SSR.

Textbooks for higher and secondary specialized educational institutions

1. Bakuradze, O. M., "Dialectic Materialism" ((Published by the Tbilisi State University, 1973).

Submitted by the Batumskiy State Pedagogical Institute imeni Sh. Rustaveli, Ministry of Higher and Secondary Specialized Education of the Georgian SSR.

2. Kemkhadze, Sh. S., "Advanced Algebra," (Published by the Tbilisi State University, 1972).

Submitted by the Batumskiy State Pedagogical Institute imeni Sh. Rustaveli, Ministry of Higher and Secondary Specialized Education of the Georgian SSR.

3. Tkeshelashvili, N. M., Beradze, S. L., Sultanishvili, Z. G., Demetrashvili, T. A., Rekhviashvili, A. G., "Political Economy," (GANATLEBA, 1975).

Submitted by the Tbilisi Order of the Labor Red Banner State University, Ministry of Higher and Secondary Specialized Education, Georgian SSR.

In publishing the list of works accepted for participation in the competition for the State Prize of the Georgian SSR in the area of science and technology for 1977, the committee requests that the Soviet public express its opinion about these works as to content and as to the composition of the authors' collectives that have been presented.

The committee asks that directors of scientific and scientific-technical societies, institutions, enterprises and higher educational institutions organize public discussions of the above works and the composition of the authors' collectives.

Opinions and criticisms, as well as materials for public discussion should be sent to the committee before 10 February 1977 at the following address: 380004, City of Tbilisi, Dzerzhinskogo Street, Academy of Sciences of the Georgian SSR, the Committee for State Prizes of the Georgian SSR attached to the Soviet of Ministers of the Georgian SSR, third floor, room 41, telephone: 99-61-42.

8228

CSO: 1870

END