

Award Number: DAMD17-99-2-9020

TITLE: Design, Fabrication, and Testing of a Portable Suction Pump

PRINCIPAL INVESTIGATOR: Mark F. Costello, Ph.D.

CONTRACTING ORGANIZATION: Oregon State University
Corvallis, Oregon 97331

REPORT DATE: April 2000

TYPE OF REPORT: Final

PREPARED FOR: U.S. Army Medical Research and Materiel Command
Fort Detrick, Maryland 21702-5012

DISTRIBUTION STATEMENT: Approved for public release; distribution unlimited

The views, opinions and/or findings contained in this report are those of the author(s) and should not be construed as an official Department of the Army position, policy or decision unless so designated by other documentation.

DTIC QUALITY INSPECTED 3

20000329 047

REPORT DOCUMENTATION PAGEForm Approved
OMB No. 074-0188

Public reporting burden for this collection of information is estimated to average 1 hour per response, including the time for reviewing instructions, searching existing data sources, gathering and maintaining the data needed, and completing and reviewing this collection of information. Send comments regarding this burden estimate or any other aspect of this collection of information, including suggestions for reducing this burden to Washington Headquarters Services, Directorate for Information Operations and Reports, 1215 Jefferson Davis Highway, Suite 1204, Arlington, VA 22202-4302, and to the Office of Management and Budget, Paperwork Reduction Project (0704-0188), Washington, DC 20503

1. AGENCY USE ONLY (Leave blank)	2. REPORT DATE April 2000	3. REPORT TYPE AND DATES COVERED Final (15 Mar 99 - 14 Mar 00)
---	-------------------------------------	--

4. TITLE AND SUBTITLE Design, Fabrication, and Testing of a Portable Suction Pump	5. FUNDING NUMBERS DAMD17-99-2-9020
---	---

6. AUTHOR(S) Mark F. Costello, Ph.D.
--

7. PERFORMING ORGANIZATION NAME(S) AND ADDRESS(ES) Oregon State University Corvallis, Oregon 97331 E-MAIL: costello@enr.orst.edu	8. PERFORMING ORGANIZATION REPORT NUMBER
--	---

9. SPONSORING / MONITORING AGENCY NAME(S) AND ADDRESS(ES) U.S. Army Medical Research and Materiel Command Fort Detrick, Maryland 21702-5012	10. SPONSORING / MONITORING AGENCY REPORT NUMBER
--	---

11. SUPPLEMENTARY NOTES

12a. DISTRIBUTION / AVAILABILITY STATEMENT Approved for public release; distribution unlimited	12b. DISTRIBUTION CODE
--	-------------------------------

13. ABSTRACT (Maximum 200 Words) The objective of this project was to design and develop a lightweight, compact, effective, and easily operated medical suction pump for the Walter Reed Army Institute of Research. Current battlefield suction pumps are substandard in their performance; these commercially available, hand-powered suction pumps are large and have low durability, making them unsuitable for use in the field. Using initial design requirements provided by the military, research was performed to determine the best concepts for the application. Two of these concepts were developed first into product designs, then into working prototypes. These prototypes were evaluated against off-the-shelf suction pumps using the provided design guidelines. It was found that the prototypes outperformed the commercial pumps in weight, size, and suction.

14. SUBJECT TERMS Mechanical Design, Fabrication, Suction, Pump, Testing, Device	15. NUMBER OF PAGES 80
	16. PRICE CODE

17. SECURITY CLASSIFICATION OF REPORT Unclassified	18. SECURITY CLASSIFICATION OF THIS PAGE Unclassified	19. SECURITY CLASSIFICATION OF ABSTRACT Unclassified	20. LIMITATION OF ABSTRACT Unlimited
--	---	--	--

NSN 7540-01-280-5500

Standard Form 298 (Rev. 2-89)
Prescribed by ANSI Std. Z39-18
298-102

FOREWORD

Opinions, interpretations, conclusions and recommendations are those of the author and are not necessarily endorsed by the U.S. Army.

___ Where copyrighted material is quoted, permission has been obtained to use such material.

___ Where material from documents designated for limited distribution is quoted, permission has been obtained to use the material.

___ Citations of commercial organizations and trade names in this report do not constitute an official Department of Army endorsement or approval of the products or services of these organizations.

N/A In conducting research using animals, the investigator(s) adhered to the "Guide for the Care and Use of Laboratory Animals," prepared by the Committee on Care and use of Laboratory Animals of the Institute of Laboratory Resources, national Research Council (NIH Publication No. 86-23, Revised 1985).

N/A For the protection of human subjects, the investigator(s) adhered to policies of applicable Federal Law 45 CFR 46.

N/A In conducting research utilizing recombinant DNA technology, the investigator(s) adhered to current guidelines promulgated by the National Institutes of Health.

N/A In the conduct of research utilizing recombinant DNA, the investigator(s) adhered to the NIH Guidelines for Research Involving Recombinant DNA Molecules.

N/A In the conduct of research involving hazardous organisms, the investigator(s) adhered to the CDC-NIH Guide for Biosafety in Microbiological and Biomedical Laboratories.

M.F. Costello *3/10/00*

PI - Signature

Date

TABLE OF CONTENTS

Cover.....	1
SF 298.....	2
Foreword.....	3
Body	
1. Introduction.....	5
2. Design Requirements.....	6
3. Conceptual Design.....	8
3.1 WRAIR.....	8
3.2 Internet Search.....	9
3.3 Patent Search.....	11
3.4 New Concepts.....	13
3.5 Concept Evaluation.....	15
4. Detailed Design.....	16
4.1 Reverse Bike Pump.....	16
4.2 Double Piston Assembly.....	16
5. Device Testing.....	19
5.1 Vitalograph.....	23
5.2 Res-Q-Vac.....	23
5.3 V-Vac.....	24
5.4 Reverse Bike Pump.....	25
5.5 Double Piston Assembly.....	25
6. Conclusions and Recommendations.....	27
Key Research Accomplishments.....	28
Reportable Outcomes.....	29
References.....	30
Appendix A: Figures.....	31
Appendix B: Tables.....	77

1. INTRODUCTION

Suction pumps are an important tool for medical personnel who need to clear fluids from wounded or sick patients. Clearing the airway of fluid and debris is the first task of the medic on the battlefield. The fluid that must be cleared can vary from water or blood, to mucous or vomit. Usable suction tools must take all of these types of fluids into consideration. Battlefield suction pumps currently available for use by the United States Armed Forces are substandard in their performance. On one hand, many operating room suction pumps are available which exhibit excellent suction characteristics. These devices are generally large and heavy and thus not suitable for the battlefield environment. There are also several human powered suction devices that are commercially available. These devices are relatively lightweight but are undesirable for use in the field, due to large size and low durability. This report documents a product development effort aimed at creating a suction pump that is lightweight, compact, removes fluid effectively, and easy to use by any soldier or medic in the field.

2. DESIGN REQUIREMENTS

This design will focus on suction pumps to be used by medical personnel in a combat environment. Soldiers require specialized equipment as they operate in unique situations. General requirements include physical attributes of the pump, pump functionality, human factors, and overall lifecycle of the pump. Physical requirements include size and weight restrictions, as well as durability. Functionality is described by such attributes as the vacuum pressure, use of attachments, and sensitivity of the pump to particles in the fluid. Human factors include the threat of contamination to the medic and the ease of use of the device. Lifecycle requirements take into account the production and disposal of the pump.

This design effort used the work of the Walter Reed Army Institute of Research (WRAIR) as a starting point to determine a set of useful design requirements and to generate some initial concepts. WRAIR furnished an initial set of design guidelines for important design variables including:

- 1) Total Device Volume $\leq 75 \text{ in}^3$ or less (1230 cm^3).
- 2) Weight ≤ 300 grams.
- 3) Dimensions $\leq 3'' \times 4'' \times 5''$.
- 4) Fluid volume of 200-400 ml in first use.
- 5) Peak pressure of 90-200 mmHg.
- 6) Easy replacement of reservoir preferred.

Many soldiers are particular about the type of equipment they carry. The major requirements of the medic are for a small, light, and durable unit that is easy to operate. Functionality and ease of use are also very important factors. In addition to these requirements,

the design team added that ease of production be a factor so that prototypes could be produced using readily available materials. Figure 1 represents a QFD diagram used to focus the development team on key requirements.

As can be seen from the four lower rows of Fig. 1, there is significant potential for improvement between the existing commercial devices and the design requirements.

3. CONCEPTUAL DESIGN

To begin the conceptual design process, both existing production suction pump designs and patented suction pump concepts were reviewed for their utility. Also, ideas from the current developer were reviewed and documented. Following a review of the state-of-the-art in suction pump design, several original concepts were generated. After generating a rich variety of suction pump ideas, the concepts were down-selected to the three most promising designs. The following sections document current devices, new concepts, and the concept evaluation process.

3.1 WRAIR

Initially, Major Calkins of WRAIR demonstrated five current, off-the-shelf devices. All five devices met the above requirements to an acceptable degree. These devices are shown in Figures 2 through 6.

The Vitalograph, shown in Figure 2, operates by creating a vacuum that sucks the desired fluid into a chamber at the rear of the device. Specifically, when the trigger is pulled, a piston is displaced, and a vacuum is produced. A ball valve at the back of the device closes when the piston is displaced, causing the fluid to be sucked into the collection chamber. When released, a spring returns the trigger to its original position, the ball valve is released, and the fluid is ejected from the chamber. A mesh filter separates any large particles that may clog the system. The Vitalograph also contains an overspill facility to remove excess fluid.

The Res-Q-Vac, shown in Figure 3, operates on the same principle as the Vitalograph. Unlike the Vitalograph, the Res-Q-Vac does not include an overspill consideration.

The V-Vac, shown in Figure 4, is the pump used most by combat medics. Its popularity is due mainly to its physical characteristics. This system consists of a collection unit that clips

into a spring-powered actuating handle. Upon spring recoil, the collection chamber is compressed, and a vacuum is produced. A trefoil valve in the catheter tip seals the chamber during compression. Air and excess liquid leave the collection chamber through a rubber flap valve. A sponge and cap cover the flap valve. The sponge reduces spray and the cap releases if the chamber becomes full.

Figure 5 shows the Ambu-Twin Pump. In this pump, a pivoted pedal elevates a diaphragm and produces a vacuum within the pump chamber. As the vacuum is produced, an entry valve opens and an exit valve closes to transmit the vacuum to the catheter. The fluid is retained in a removable collection chamber by a float valve. Springs return the pedal to its original position after release.

The basic 60-cc syringe, shown in Figure 6, can also be used as a suction device. Syringes are inexpensive and provide good suction capabilities. Some disadvantages are that they require two-handed operation and have a limited capacity.

3.2 INTERNET SEARCH

A search of the internet provided five existing suction devices that were related to the design requirements.

The first useful pump noted was the Ambu Power Pack Suction unit. Figure 7 shows this device and some of its specifications. This is an electrically powered device that provides instant suction whenever it is needed. This device is powered by AC or DC power sources and can also run for an hour using a built in battery. It offers peak suction power of 500 mm Hg and a switch that offers different levels of suction power. This device is not only easy to use, but it also keeps safety and sterility in mind. The device comes with a disposable reservoir that will

stop suction immediately when the reservoir is full. This prevents fluid from getting into the suction device itself and from flowing out of the container. The device weighs approximately 4.8 lbs. and has a footprint of 290 cubic inches.

The second suction device noted was the Impact Vac-Pak II shown in Figure 8. The Vac-Pak is a battery-powered device that provides a high vacuum. This device is considered lightweight for a battery-powered pump, while maintaining its performance. Variable size canisters are available.

Figures 9 and 10 show the S-SCORT "9" and S-SCORT "10" suction pumps. These pumps are battery-powered devices and boast of their durability. Their stainless steel chassis have been designed to absorb sound, making this device extremely quiet. Another important feature is the disposable fluid path, which accommodates sterility. It has a two vacuum-power position regulator and a maximum suction power of 550 mm Hg. Each device encompasses approximately 1000 cubic inches of space and weighs 8 to 10 lbs. These devices are said to be "Fireman proof" and cost approximately \$600.

As shown in Figure 11, the Laerdal Compact Suction Unit is the smallest in size and weight of any other portable battery-powered unit. It can either be powered by household current or by its internal lead acid battery. It also maintains sterility by use of a disposable suction tube and canister. It encompasses approximately 275 cubic inches of space and weighs just under 4 lbs.

3.3 PATENT SEARCH

A patent search was conducted to uncover any existing products that might satisfy some or all of the design requirements. An in-depth perusal of the U.S. Patent Office via the Internet (www.patents.ibm.com) using 'suction pump' as the key word, provided 430 hits. Six of the patents were relevant to the current design effort.

Figure 12 shows a sketch of the first patent noted, namely, U.S. Patent 5,102,404, issued to Uresil Corporation on 2 October 1990. This design is one of several human powered suction devices to be discussed. This design uses the same type of suction concept as the V-Vac. The main difference is in the use of valves. This design uses valves to either increase the size of collection area or reduce the size of the suction device itself. This design also offers a fluid storage unit similar to that of blood bags for easy analysis of fluid contents.

The second patent noted was U.S. Patent 5,318,548 issued to Regent Limited on 26 June 1991. This concept was designed for the purpose of clearing the nasal cavity of a newborn baby. As shown in Figure 13, this device is basically a hand held pump powered by the thumb. This device also contains a separate compartment for the storage of the mucus.

Figure 14 shows U.S. Patent 5,167,621 issued to Surgicraft Limited on 23 January 1990. This concept uses the suction power of the mouth to provide vacuum suction to withdraw fluids from the body. Applying suction to the mouthpiece causes the elastic diaphragm to move upward causing a vacuum affect in the lower chamber. This causes the suction valve to open and allows fluid to be transferred to the lowermost chamber. The diaphragm is extremely important for the purpose of sterility. This concept was also designed so that the elastic diaphragm is self-restoring and continual suction can be applied.

The fourth patent taken into consideration was U.S. Patent 4,979,944 issued to The Pullman Company on 21 August 1991. This design uses the suction concept of a normal syringe as seen in Figure 15. The device contains a piston that can instantly be energized to a pre-selected level to attain the desired amount of suction. Another important aspect of this design is the use of inlet and exit valves on the tip of the syringe. As the piston is retracted, the fluid is sucked into the chamber through a one-way valve. As the piston is compressed, the inlet valve closes and outlet valve opens, causing the contents of the tube to be expelled in a discharge reservoir. The addition of these inlet and exit valves allow for increased volume of fluid to be sucked out of the body.

U.S. Patent 5,009,635 issued to Respiromics Inc. on 6 November 1989, and depicted in Figure 16, uses the suction properties of a resilient rubber bulb. On either side of the bulb are located two one-way flow check valves. Fluid is sucked through a tube connected to the inlet valve, through the bulb, and out the exit valve on the other side to be discharged into a container. This combination of valves not only prevents backflow of fluid back into the patient, but also increases the amount of fluid that can be taken from a body.

The final patent noted was U.S. Patent 4,930,997 issued to Alan N. Bennett on 19 August 1987. This device, seen in Figure 17, utilizes the suction properties of a rotary pump. This pump is attached to an inlet tube and exit tube through which fluid passes into a disposable collection bag. This pump was intended to be powered by an electric motor, but could be attached to a crank and operated manually.

3.4 NEW CONCEPTS

The review of existing suction pump designs combined with informal brainstorming sessions provided several new concepts for a suction device. The following shows a sketch of each concept and provides a short description of its functionality.

Figure 18 shows a concept that was generated with the intent of simplifying the principle of the V-Vac. The accordion type chamber would have to be easy to depress with the strength of one hand. The concept is simple and has few moving parts. Material selection would affect the weight of the device.

Figure 19 was generated as an adaptation of the bulb device used in Concept 15. Different valves and attachment capabilities are required to optimize and contain the size of particles to be transported through the pump. The size and resilience of the bulb are also a concern. A bigger bulb may need to be formed to accommodate the appropriate pressure levels. The bulb may need to be made from a more resilient material to retain its uncompressed state quickly.

Another concept was developed which uses the operating principle of a syringe. This concept is shown in Figure 20. This concept allows for an unlimited capacity of fluid to be removed from the body by the use of valves. The idea of using existing syringes in the manufacture of this concept is a benefit. This not only aids in the production of a prototype, but also takes advantage of a device the soldiers already carry with them. Valves would again need to be designed in such a way to allow particles to pass. This adds a great deal of complication to any concept.

Figure 21 shows the use of a bicycle pump in reverse. The goal is not to pump fluids into the body, but to remove fluids from the body. This design originated from a particular existing

bicycle pump. As the pump is extended, a vacuum is formed, and fluid is drawn in through the inlet valve. As the pump is compressed, the fluid inside the pump is forced through the exhaust valve. This device takes full advantage of suction power and unlimited capacity.

Figure 22 shows another variation of the V-Vac, adapted for a syringe. This device would operate exactly like the V-Vac, but would be smaller. Use of a syringe is preferred because they are lightweight and inexpensive.

Figure 23 shows another syringe adapter. This design would use a hand trigger device to operate the syringe.

Figure 24 depicts a piston assembly that is held in one hand. As the grip attached to the piston is depressed, it forces all fluid in the assembly's chamber through the exhaust valve. The exhaust valve closes when the piston is fully compressed. As the piston makes its return stroke, the vacuum in the chamber opens the inlet valve, drawing more fluid in through the attached tubing. The inlet valve closes when the piston returns to its initial position. This concept has the advantage of an unlimited capacity, much like the reverse bike pump concept.

Figure 25 illustrates a pump that uses collapsible household vacuum hose as the working pump vacuum chamber. The pump is initially open and is operated like a small bellows using one hand. This pump uses a box-like enclosure to protect the vacuum hose from accidental puncture. This pump has unlimited capacity, similar to the reverse bike pump and piston assembly concepts.

3.5 CONCEPT EVALUATION

After sufficiently exploring potential suction pump configuration ideas, the concepts were down-selected. Table 1 lists each concept and the inherent advantages and disadvantages of each design concept documented above.

Any concept that was overly complex, or would be unreasonably expensive or difficult to manufacture was eliminated from consideration. The following two concepts were then selected for prototype construction:

1. Reverse Bike Pump (Concept 20)
2. Double Piston Assembly (Concept 23)

4. DETAILED DESIGN

Once the concepts for prototyping were determined, detailed assembly information was generated and the required parts were procured. This section documents the detailed design and fabrication process for each prototype constructed.

4.1 REVERSE BIKE PUMP (CONCEPT 20)

The Reverse Bike Pump concept was modeled after the bike pump made by *Avenir*, called the “AirMax Pocket II.” However, Concept 20 uses mostly custom parts to stay within WRAIR engineering requirements. A picture of a working Reverse Bike Pump is given in Fig. 26. Figures 27 and 28 illustrate the unexploded and exploded assemblies of the Reverse Bike Pump, respectively. Figures 29-36 are engineering drawings of the pump’s custom-made parts; these parts were machined at *OSU Engineering Services*.¹ Table 2 lists the parts used to construct the Reverse Bike Pump.

Aluminum round stock was machined to create the housing-tube, shown in Fig. 29, and the piston-tube, shown in Fig. 33. The aluminum used was 6061-T6, obtained from *OSU Engineering Services*.¹ The piston-tube slides within the housing-tube to produce suction, and is sealed by two 3/32-inch thick, 3/4-inch inner-diameter o-rings, bought at *True Value Hardware*.² A stop was machined into the end of the housing-tube to prevent the piston-tube from being removed. It was found that Dow Corning High Vacuum Grease eased the sliding movement of the piston-tube within the housing tube and helped maintain a proper seal between the two tubes.

Medical tubing that is 3/8-inch outer diameter may be attached to the pump prototype using its quick-connect fittings (not shown). The fittings were obtained from *McMaster-Carr*.³

¹ OSU Engineering Services, 110 Merryfield, Corvallis, OR 97331-3211, (541) 737-2355.

Other quick-connect fittings (which use a 1/4-inch NPTF male thread) may be exchanged with the 3/8-inch fitting for other sizes of tubing.

Inlet and exhaust valves are threaded into the ends of the two aluminum tubes to ease assembly and cleaning. Both of these valves use a ball-check design, supplemented by a spring to keep the valve normally closed in all orientations. The valve design uses a 3/8-inch diameter, 304 stainless steel ball obtained from *McMaster-Carr*³, and a 0.312 outer-diameter, stainless steel spring, purchased from *Trakar*.⁴ This spring was selected for its spring rate, 0.43 lbs/in., and its length, 1.062 in. to operate in the required pressure range. The ball and spring operate within a small tube machined from acrylic round stock, shown in Fig. 29, which was obtained from *HyTEK Plastics*.⁵ Two of these acrylic tubes screw into two valve housings, depicted in Figs. 30-31. The housings are machined from polycarbonate rod, acquired from *McMaster-Carr*.³ As flow pressure is applied to the inlet opening of either valve, or more specifically, the stainless steel ball, the pressure causes the ball to retract and the spring to compress. This allows liquid and particles to pass. When no pressure is applied, the spring keeps the valve closed by forcing the ball to seal against the opening. A rubber washer aids the seal at this opening. The washer, shown in Fig. 36, is cut from a stock sheet of 1/16" thick silicone rubber from *McMaster-Carr*.³

Once machining was completed for the custom parts, the Reverse Bike Pump was assembled as follows:

1. A *Trakar* spring was inserted into each acrylic Milled-Tube.

² True Value Hardware, 2001 NW Circle Blvd., Corvallis, OR 97330, (541) 754-2920.

³ McMaster-Carr, P.O. Box 54960, Los Angeles, CA 90054-0960, (562) 692-5911.

⁴ Trakar Products Inc., 225 Boida Avenue, RR#1, Ayr, Ontario, Canada, (800) 866-9525.

⁵ HyTEK Plastics, 1160 SE Alexander Ave., Corvallis, OR 97333, (541) 754-2261.

2. A 3/8-inch stainless steel ball was inserted into each Milled-Tube on top of the spring.
3. A washer was inserted into both Housing-A and Housing-B in the blind hole containing 1/2-20 NF threads.
4. Both Milled-Tube/Ball/Spring assemblies were threaded into the 1/2-20 NF blind holes in both Housing-A and Housing-B.
5. The o-rings were snapped into the grooves on the Piston Tube.
6. The inside of the smaller diameter section of the Housing Tube and the o-ring section of the Piston Tube were both lubricated with Dow Corning High Vacuum Grease.
7. The threaded end of the Piston Tube was inserted into the Housing Tube and pulled through until it stopped.
8. A brazing rod was bent and cut so that it could be inserted into the 0.96-inch holes in Housing-A, Housing-B, and the End-Cap. The bent rod is used as a tool to screw these parts into threaded holes.
9. Using the bent brazing rod, Housing-B was screwed into the 0.500-inch depth threads of the End-Tube.
10. The 5/8-18 NF threaded end of the Piston-Tube was wrapped with Teflon tape and screwed into Housing-B.
11. A quick-connect fitting was screwed into the 1/4 NPTF threads of the End-Cap. The End-Cap's 1-14 NF threads were wrapped with Teflon tape and screwed into the open end of the End-Tube.
12. The 1-14 NF threads of Housing-A were wrapped with Teflon tape, and using the bent brazing rod, screwed into the open end of the Housing Tube.

13. Finally, a quick-connect fitting was screwed into the ¼ NPTF threads of Housing-A.

4.2 DOUBLE PISTON ASSEMBLY (CONCEPT 23)

The Double Piston Assembly is a slightly modified version of the concept illustrated in Fig. 24. This prototype is easiest to operate by placing the small plate in your palm, wrapping your fingers around the main body, and squeezing the two together. A prototype with a single piston was produced, but early pressure testing indicated that the pump would not meet the WRAIR pressure requirement of 90 mm Hg. Therefore, a second piston was added to the design. A working prototype of the modified design is pictured in Fig. 37. Figures 38 and 39 give unexploded and exploded illustrations of the suction pump. Figures 40-48 are engineering drawings required to produce the custom-made parts; these parts were machined at *OSU Engineering Services*.¹ Table 3 lists the parts needed to construct the Double Piston Assembly.

This pump uses the same ball/spring check-valve design as the Reverse Bike Pump concept, and a description of the check-valve can be found in Section 4.1. Like the Reverse Bike Pump, the check valves thread into each end of the Double Piston Assembly housing. The housing is machined from nylon 6/6 bar stock, obtained from *McMaster-Carr*.³ The housing, shown in Fig. 41, has two counter-bored holes with a 32-microinch surface finish, suitable for pistons sealed by o-rings to slide without being damaged by wear. The vacuum for the pump is created from the displaced volume between the pistons and the housing. The pistons used in this concept, depicted in Fig. 40, are machined from nylon 6/6 rod, obtained from *McMaster-Carr*.³ Each piston is sealed using two 1/8-inch thick, 3/4-inch outer-diameter, Buna-N o-rings obtained from *OSU Engineering Services*.¹ Dow Corning High Vacuum Grease, obtained from *OSU*

Engineering Services,¹ decreases the sliding friction of the piston o-rings, thereby making the pump easier to use. Both pistons are kept in an extended condition by compression springs obtained from *McMaster-Carr*.³ They are 0.48-inch outer-diameter, 19.13 lb./in. spring rate, 1.5-inch long, stainless steel springs. A small rounded palm plate, shown in Fig. 47 is machined from a ¼-inch nylon 6/6 sheet. The palm plate connects the pistons, and is attached by two Ø 6-32 screw fasteners, one on each piston. A small ¼-inch cover, also made from nylon 6/6 sheet, allows easy access to the pistons and springs. This back cover, given in Fig. 45, is attached to the pump housing by six Ø 6-32 fasteners. It is important that the cover be fastened securely to the housing to maintain a tight seal. The ¼-inch nylon sheet was purchased from *McMaster-Carr*³ and the fasteners were obtained from *OSU Engineering Services*.¹ Like the Reverse Bike Pump, the Double Piston Assembly uses 3/8-inch quick-connect fittings obtained from *McMaster-Carr*.³

After all of the custom parts were machined, the Double Piston Assembly was put together in the following order:

1. A *Trakar* spring was inserted into each Milled Tube.
2. A 3/8-inch stainless steel ball was inserted into each Milled Tube on top of the spring.
3. A washer was inserted into the blind ½-20 NF hole in both Housing-A and Housing-D.
4. The milled tube/ball/spring assembly was screwed into the ½-20 NF hole in both Housing-A and Housing-C.
5. A brazing rod was bent and cut so that it could be inserted into the 0.96-inch holes in Housing-A, Housing-C, and the End-Cap. The bent rod is used as a tool to screw these parts into threaded holes.

6. Housing-A's 1-14 NF threads were wrapped with Teflon tape and screwed into the 0.600-inch deep threads of the Housing Block, using the bent brazing rod.
7. Housing-C was wrapped with Teflon tape and threaded into the opposite end of the Housing block using the bent brazing rod.
8. O-rings were snapped onto each of the Pistons.
9. The two counterbored holes in the Housing Block and the Piston o-rings were lubricated with Dow Corning High Vacuum Grease.
10. The two Pistons were inserted and pulled through the counterbored holes of the Housing Block.
11. The Palm Plate was attached to each piston using a $\text{\O} 6-32$ fastener.
12. A piston spring was inserted into the $\frac{1}{2}$ -inch hole in each piston.
13. The Back Cover was attached to the Housing Block using six $\text{\O} 6-32$ fasteners.
14. Housing-D was wrapped with Teflon tape and screwed into the Housing in the same end as Housing-C, using the bent brazing rod.
15. A quick connect fitting was screwed into the $\frac{1}{4}$ NPTF threaded holes of both Housing-A and Housing-D.

5. DEVICE TESTING

Each device was measured and tested to determine its size, weight, dimensions, fluid capacity for the first use, and peak pressure. The weight was measured on a Triple Beam Balance. Dimensions were measured directly with a ruler. Each device was submerged under water, using the displaced water volume to determine the volume of the device. The fluid capacity was measured as the amount of water the device could hold in its reservoir before it began overflowing or malfunctioning. The peak suction pressure achieved by each device was measured with a 0-30 psig, 128KB *Smart Reader Plus* pressure transducer and data-logger. The pressure data was analyzed using *TrendReader for Windows* software. Both the data-logger and software were obtained from *Davis Instruments*.⁶ Two different methods were used to obtain peak vacuum gauge pressure data for each device. First, each device was attached directly to the transducer to determine its dry suction potential, as shown in Fig. 49. Next, the transducer, pump, and tubing were attached using a tee fitting, as depicted in Fig. 50, to monitor the vacuum pressure while the device removed water from a bucket. Both the dry and wet tests were performed five times for each device, and at each test, the device was monitored for 25 strokes. The peak pressure from each run was averaged over the five tests. In both cases, the peak pressure was obtained by subtracting the lowest pressure achieved during a test from the ambient room pressure. The averaged results of these tests for each device are shown in Table 4.

Further testing was performed on each device to determine their ability to handle particles. Soup would represent a thicker form of vomit that may congest a patient. Each device was evaluated using Campbell's Cream of Mushroom Soup, a viscous fluid with particles.

⁶ Davis Instruments, 4701 Mount Hope Drive, Baltimore, MD 21215, (800)-433-9971.

Pressure-time traces were recorded only as a means of monitoring the vacuum pressure created and the length of time used to clear a lodged particle from the tubing inlet.

5.1 VITALOGRAPH

The Vitalograph is both a heavy and awkward-shaped device. Although its volumetric size is only 30 cubic inches, the Vitalograph's weight, 362 grams, and its dimensions, 3.1 by 6.4 by 6.9 inches, well exceed the WRAIR requirements. However, its reservoir is capable of holding 224 ml of fluid, which satisfies the volume-of-first-use requirement, and its suction power is adequate. During the "dry" pressure test, the Vitalograph created an average peak vacuum gauge pressure of 460 mm Hg. Figure 52 is an example pressure-time trace for the Vitalograph during the "dry" test. During the "wet" test, however, the device only achieved an average peak pressure of 185 mm Hg. The Vitalograph's reservoir was full at the 22nd or 23rd stroke, at which point it would begin emptying the fluid through its exhaust port. The following pump strokes were immediately slower and required more hand strength to produce. The large curves in Fig. 53 illustrate the slower stroke time of the pump. No functional problems were found when it was tested on the mushroom soup; the pump was capable of accepting those particles that fit through the 3/8" tubing. Mushrooms were occasionally caught inside the tubing or at the tubing inlet, but the pump would continue to build pressure until the particle dislodged or the inlet was cleared by hand.

5.2 RES-Q-VAC

The Res-Q-Vac's all plastic construction makes it lightweight (211 grams) which easily satisfies the WRAIR weight requirement. Its physical volume is small, but its dimensions make

it a large device. It has a large fluid reservoir, which gives it an acceptable first-use volume. The Res-Q-Vac created an average peak pressure of 520 mm Hg during the “dry” test, but when it was subjected to the “wet” test, it only created an average of 214 mm Hg peak pressure. Figures 56 and 57 give example pressure-time traces of the device during these tests. The Res-Q-Vac filled its reservoir fairly quickly during the “wet” test, which resulted in the pump becoming nearly impossible to use after the 17th and 18th strokes. The pump had no problem with particles; any particles that fit through the 3/8-inch tubing were brought into the reservoir. If a particle became wedged in the tubing or at the inlet, the pump would build pressure until the particle dislodged itself or was cleared from the inlet by hand. An example of the pump pressure during the soup test is given in Fig. 58.

5.3 V-VAC

The V-Vac is a large and moderately heavy device. Although its volumetric size is small compared to the WRAIR requirement, its large and awkward dimensions, 2.8 by 4.8 by 15.3 inches, make it very undesirable to carry in a field medic pack. Its 252 gram weight falls under the WRAIR requirement, and its volume of first use is more than acceptable. The V-Vac created an acceptable peak suction pressure of 210 mm Hg during the “dry” test. Figure 60 shows an example pressure-time trace during the “dry” test. It fell under the WRAIR requirement on the “wet” test by producing an average of 54 mm Hg peak pressure. During this test, the V-Vac would fill its reservoir at the 20th or 21st stroke, and would become much more difficult to pump at that point, which is apparent in Fig. 61. The water would empty from the pump’s exhaust valve, but it retracted very slowly and required much more hand strength. The pump had

significant problems with particles; it took more than 30 seconds of pumping to clear a few small mushrooms stuck in its trefoil valve, as is seen in Fig. 62.

5.4 REVERSE BIKE PUMP

The Reverse Bike Pump prototype is very lightweight, only 159 grams, and very small. The pump stayed within all of the WRAIR size requirements except for one; the length of the pump, 8.4 inches, exceeded the five-inch requirement. It produced an average peak pressure of 377 mm Hg for the “dry” test and 246 mm Hg for the “wet” test. No problems were encountered during either of these tests; example pressure-time traces are given in Figs. 64-65. Since the pump does not have a reservoir, its first-use volume is unlimited. This also requires that tubing be attached to its exhaust port to carry the fluid away from its user and the patient. In addition, any particles encountered must pass through the valves. During the soup test, mushrooms would occasionally get trapped at the inlet valve, but the pump would build pressure until the particle was pulled through. Figure 66 gives an example pressure-time trace for the device during the soup test.

5.5 DOUBLE PISTON ASSEMBLY

The Double Piston Assembly meets all of the WRAIR requirements with the exception of its eight-inch length. Like the Reverse Bike Pump, the device lacks a reservoir, which gives it an unlimited first use. This also requires that it process particles through its valves and that it have tubing attached to its exhaust valve to carry the fluid away from user and patient. The Double Piston Assembly produces a consistently high suction pressure with each stroke; this is apparent from Figs. 68-69. The pump produced a peak pressure of 251 mm Hg during the “dry” test, and

a peak pressure of 257 mm Hg during the “wet” test. The Double Piston Assembly performed much the same as the Reverse Bike Pump during the soup test, because of the identical valves. When particles became trapped at the inlet or exhaust valve, further pumping built vacuum pressure ahead of the particle until it was pulled through. Figure 70 gives an example of the pressure-time trace of the Double Piston Assembly during the soup test.

6. CONCLUSIONS AND RECOMMENDATIONS

This reports documents the design effort aimed at furnishing WRAIR with suction pump designs that met each of their initial requirements. The effort yielded many concepts; however, only two were selected for prototype development: the Reverse Bike Pump and the Double Piston Assembly.

Both concepts proved to be very successful designs; both are very lightweight and produce consistently high suction pressure when pumping air or fluid. Both outperform the Vitalograph, the Res-Q-Vac, and the V-Vac in each of the WRAIR design requirement areas. Neither of the prototypes require a reservoir to pump fluids, which means the field medic does not have to stop to empty the reservoir while treating a patient. This means, however, that the pumps' valves must be able to pass particles. The ball/spring check-valve design allows both of these pumps to do so. The design requires that a length of tubing be attached to the exhaust valve on the pumps to carry the fluid away from the medic and patient, but produces a considerable savings in weight and size.

An area in which the prototypes could be improved is their physical length. Both designs currently use the check-valves in-line, which cause the pumps to be three inches too long. If changes are made in the design to shorten the valve design or to rearrange the placement of the valves, and to reduce the length of the pump body, the pumps could be shortened to meet the requirement.

Another recommendation is to design and construct an optional reservoir that could be attached to the quick-connect fittings of the Reverse Bike Pump and Double Piston Assembly. This would allow the pumps to be used in an area where clean-up is required.

KEY RESEARCH ACCOMPLISHMENTS

- Established a system of benchmarking human powered suction pumps for application to airway aspiration of battlefield casualties.
- Evaluated prototypes and commercial suction pumps against WRAIR design requirements.
- Development of two suction pump prototypes that outperform commercial suction pumps.

REPORTABLE OUTCOMES

- Provided a summer research position for an undergraduate mechanical engineering student.
- Provided basis for obtaining Honors Bachelor of Science Degree in Mechanical Engineering.
- Developed suction pump prototypes to be used by Armed Forces Field Medics.

REFERENCES

Arnstein, F.E. A Practical Evaluation of Four Human-Powered Portable Airway Aspirators. *Anaesthesia* 1996, Vol. 51, 63-68.

Hatfield, J.; Long, M.; Boyle, T. Design, Fabrication, and User Testing of a New Suction Pump Device. Oregon State University, 1999.

Ullman, D.G. *The Mechanical Design Process*, 2nd ed.; McGraw-Hill Publishing Companies, Inc.: New York, 1997.

APPENDIX A – FIGURES

	WRAIR	Soldiers	Pump Volumetric Size in ³	Weight grams	Dimensions inches	Volume of First Use ml	Max. Vacuum Pressure - Wet mm Hg	Max. Vacuum Pressure - Dry mm Hg	# of Parts #	Easily Replaceable Reservoir Yes / No
Physical Requirements										
Small Pump Size		1	9		3					
Lightweight		2		9					1	
Convenient Shape			3		9					
Functional Requirements										
Volume of First Use						9	3			
Good Suction		3				3	9	9		
Few Parts				1					9	
Reusable Pump										9
Concept #1: Vitalograph			30	362	3.1 x 6.4 x 6.9	224	185	460	7	Yes
Concept #2: Res-Q-Vac			31	211	2.3 x 6.7 x 7.1	221	214	520	6	Yes
Concept #3: V-Vac			38	252	2.8 x 4.8 x 15.3	318	54	210	5	Yes
Requirements			75	300	3.0 x 4.0 x 5.0	200	90	90	-	Yes

Figure 1: QFD Diagram

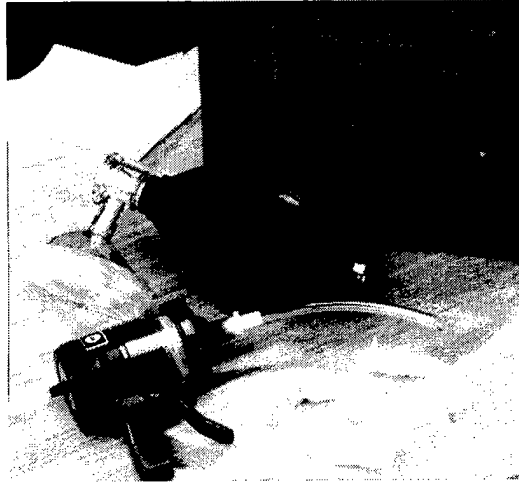

Figure 2: Vitalograph (Concept 1)

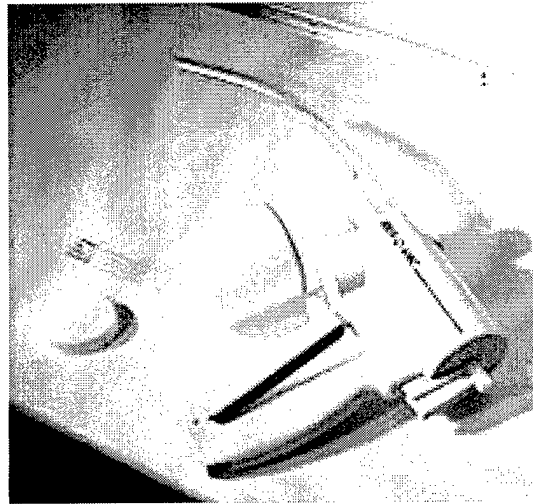

Figure 3: Res-Q-Vac (Concept 2)

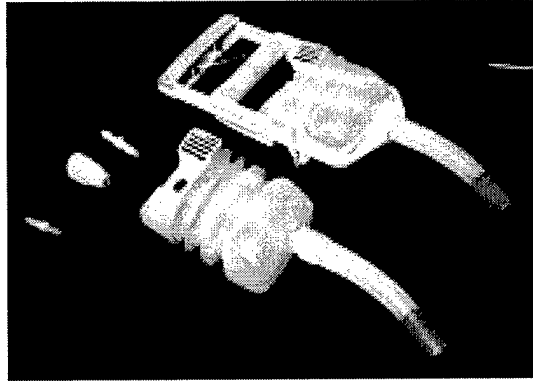

Figure 4: V-Vac (Concept 3)

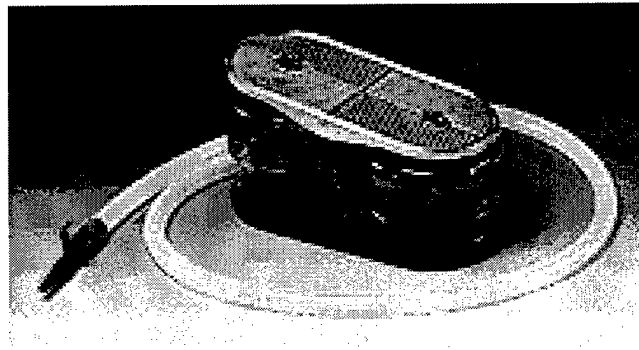

Figure 5: Ambu-Twin Suction Pump (Concept 4)

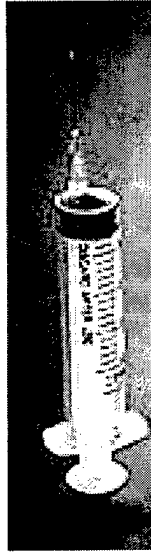

Figure 6: 60-cc Syringe (Concept 5)

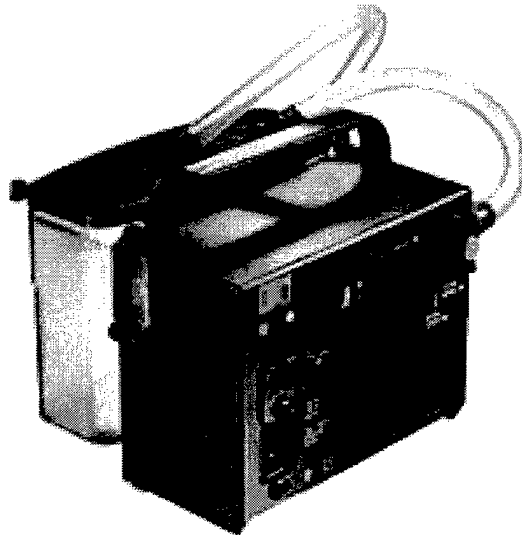

Figure 7: Ambu Power Pack Suction unit (Concept 6)

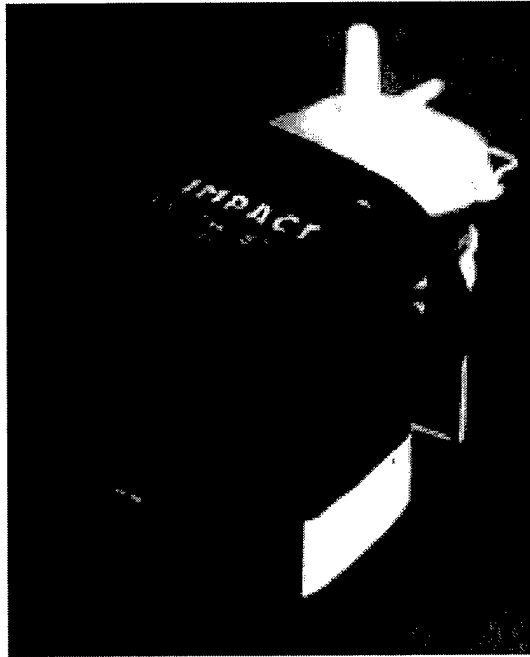

Figure 8: Impact Vac-Pak II (Concept 7)

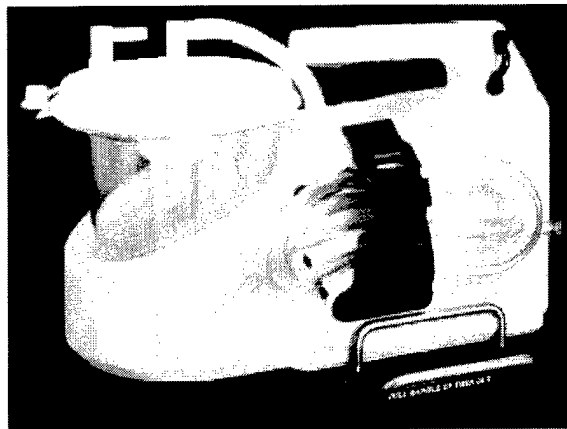

Figure 9: S-SCORT "9" (Concept 8)

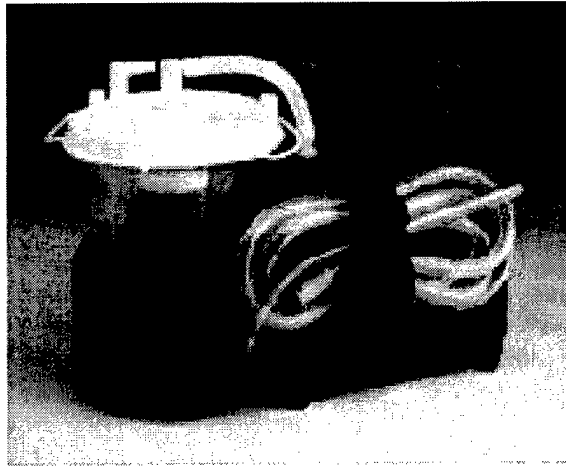

Figure 10: S-SCORT "10" (Concept 9)

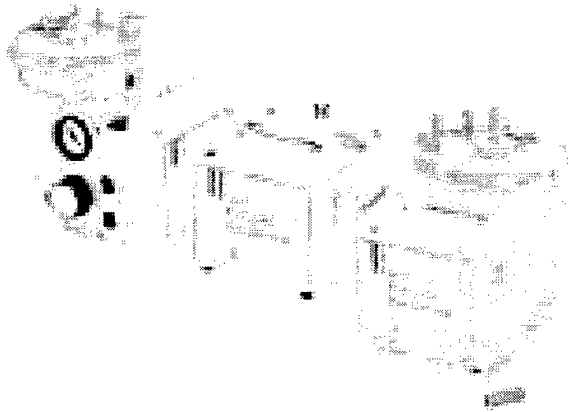

Figure 11: Laerdal Compact Suction Unit (Concept 10)

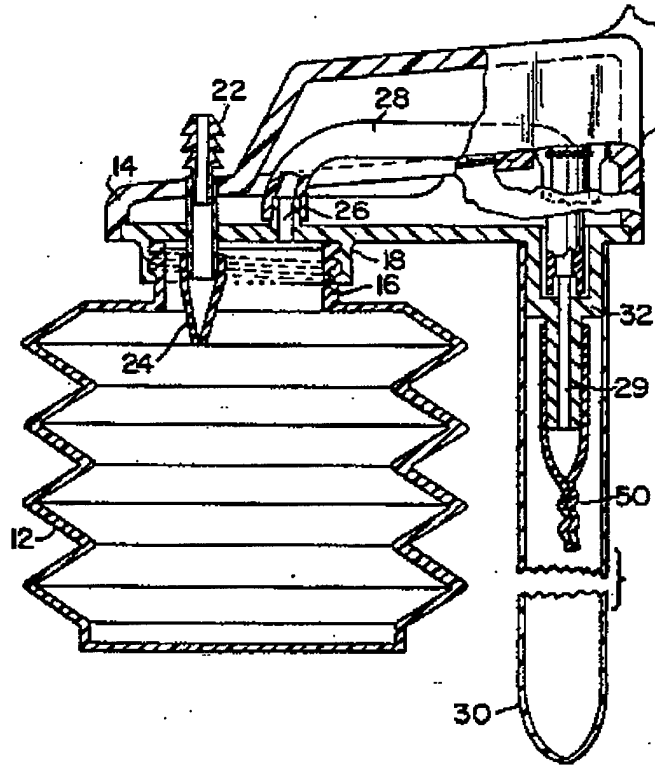

Figure 12: U.S. Patent 5,102,404 (Concept 11)

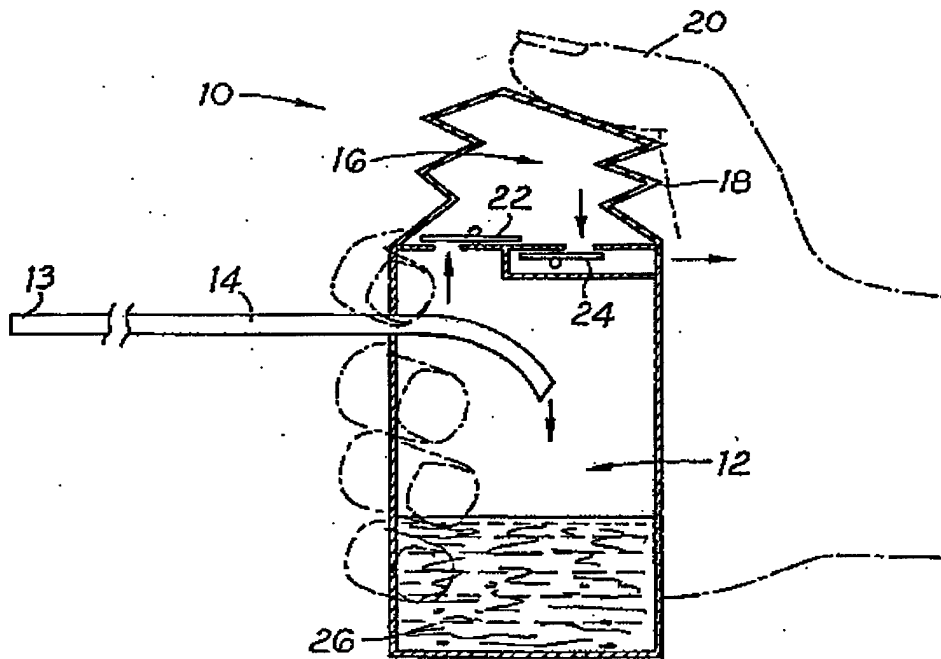

Figure 13: U.S. Patent 5,318,548 (Concept 12)

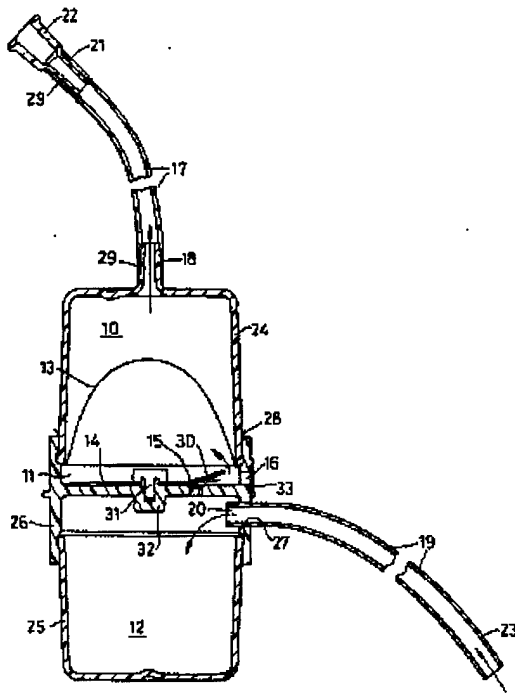

Figure 14: U.S. Patent 5,167,621 (Concept 13)

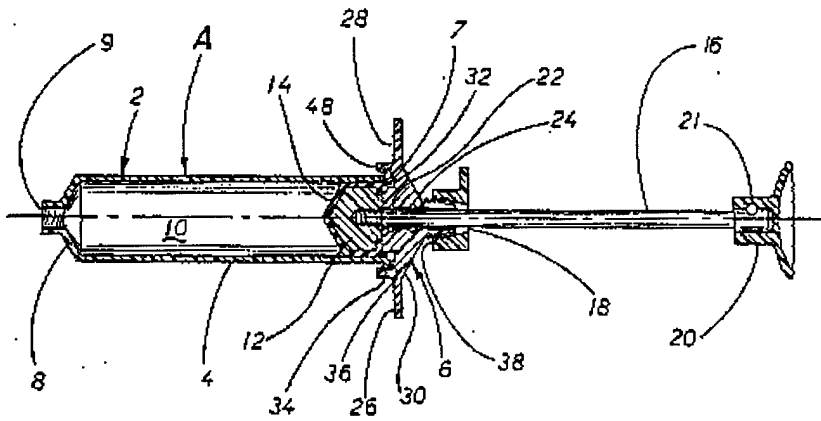

Figure 15: U.S. Patent 4,979,944 (Concept 14)

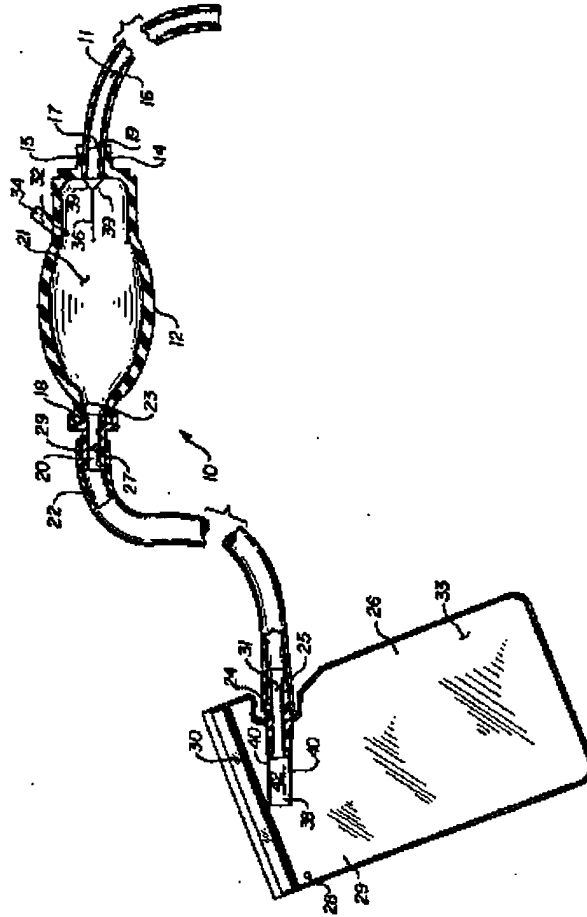

Figure 16: U.S. Patent 5,009,635 (Concept 15)

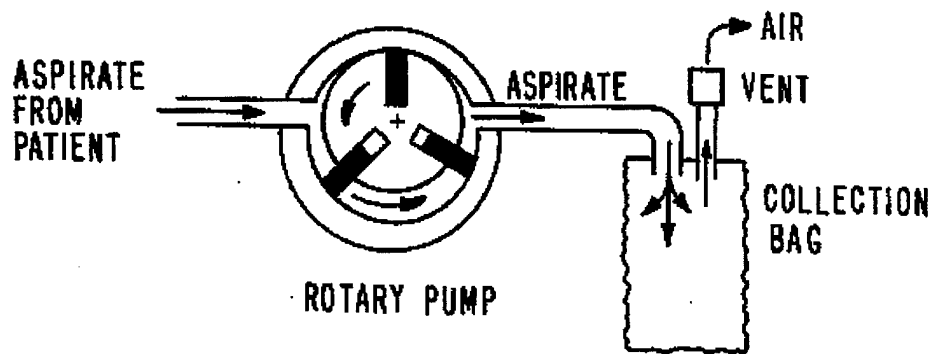

Figure 17: U.S. Patent 4,930,997 (Concept 16)

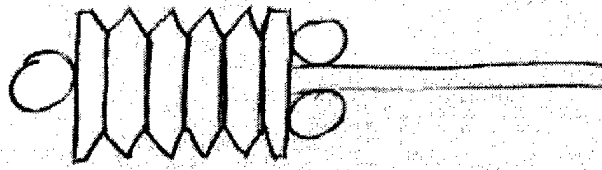

Figure 18: Mini V-Vac (Concept 17)

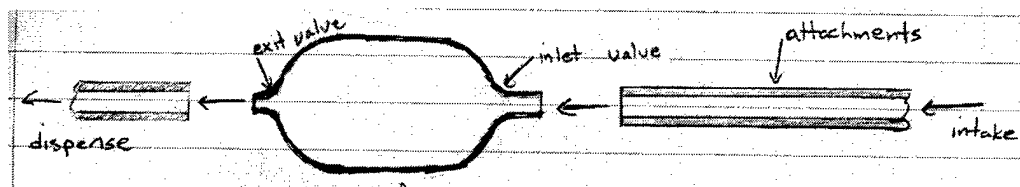

Figure 19: The Bulb (Concept 18)

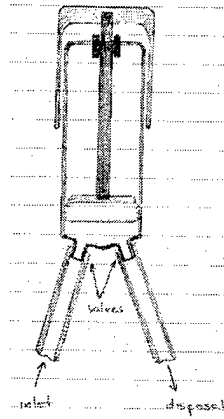

Figure 20: The Syringe Thing (Concept 19)

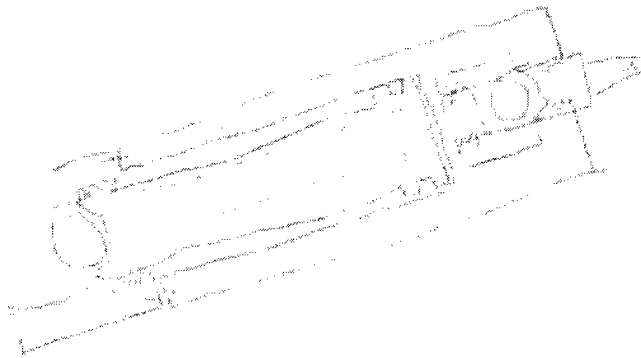

Figure 21: Reverse Bike Pump (Concept 20)

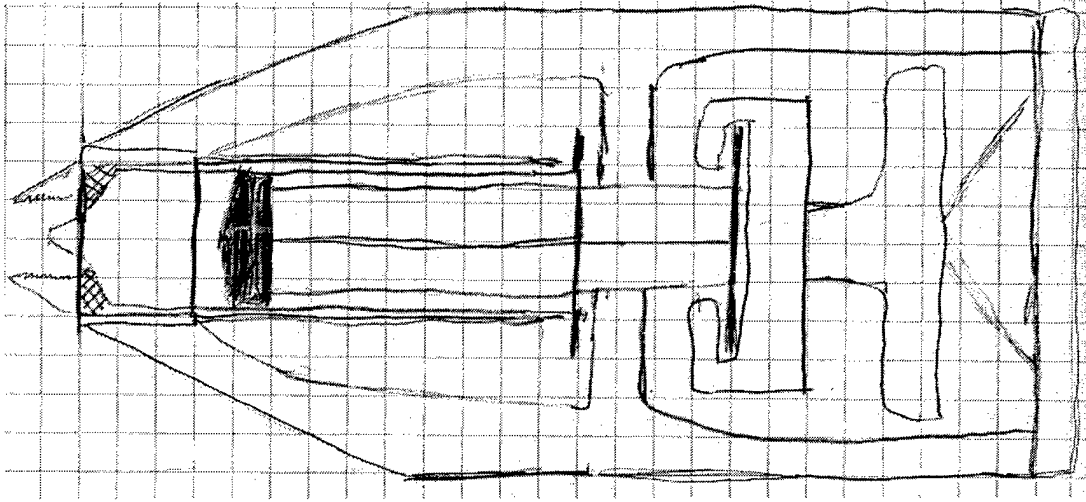

Figure 22: Modified Syringe (Concept 21)

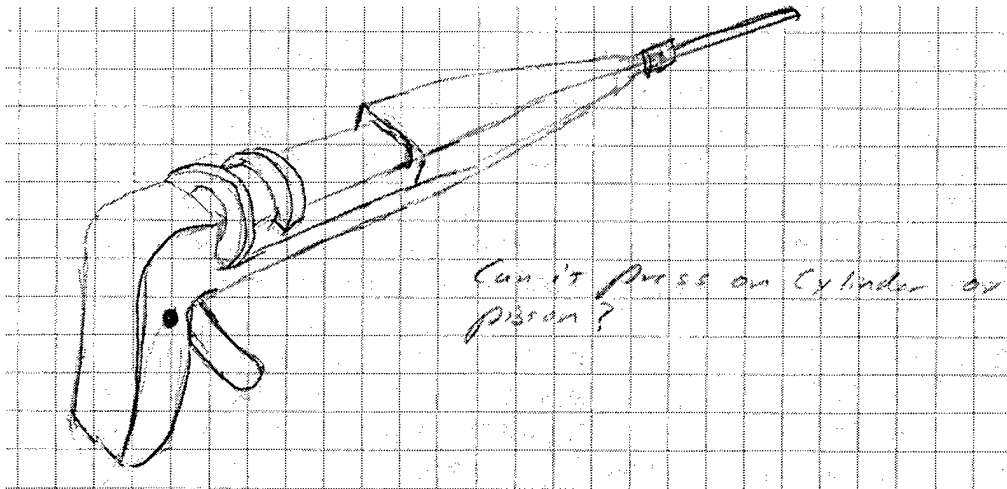

Figure 23: Trigger Activated Syringe (Concept 22)

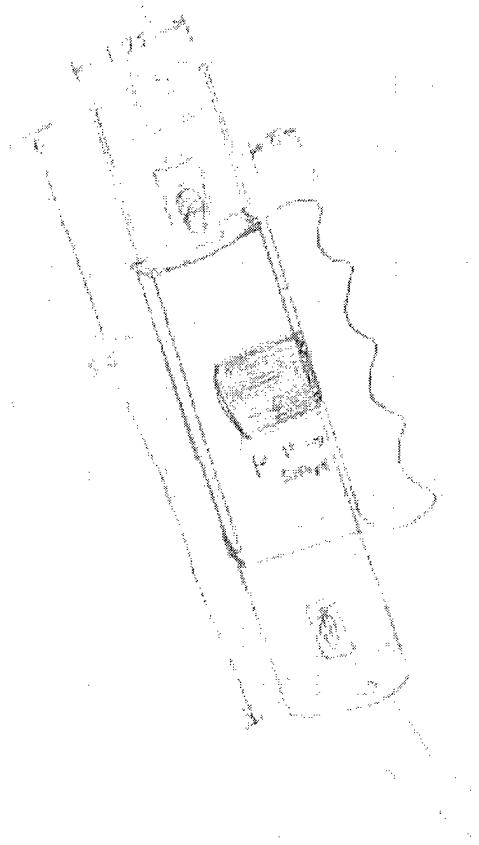

Figure 24: Piston Assembly (Concept 23)

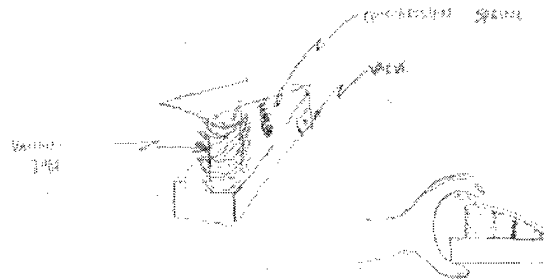

Figure 25: Hand-Held Bellows (Concept 24)

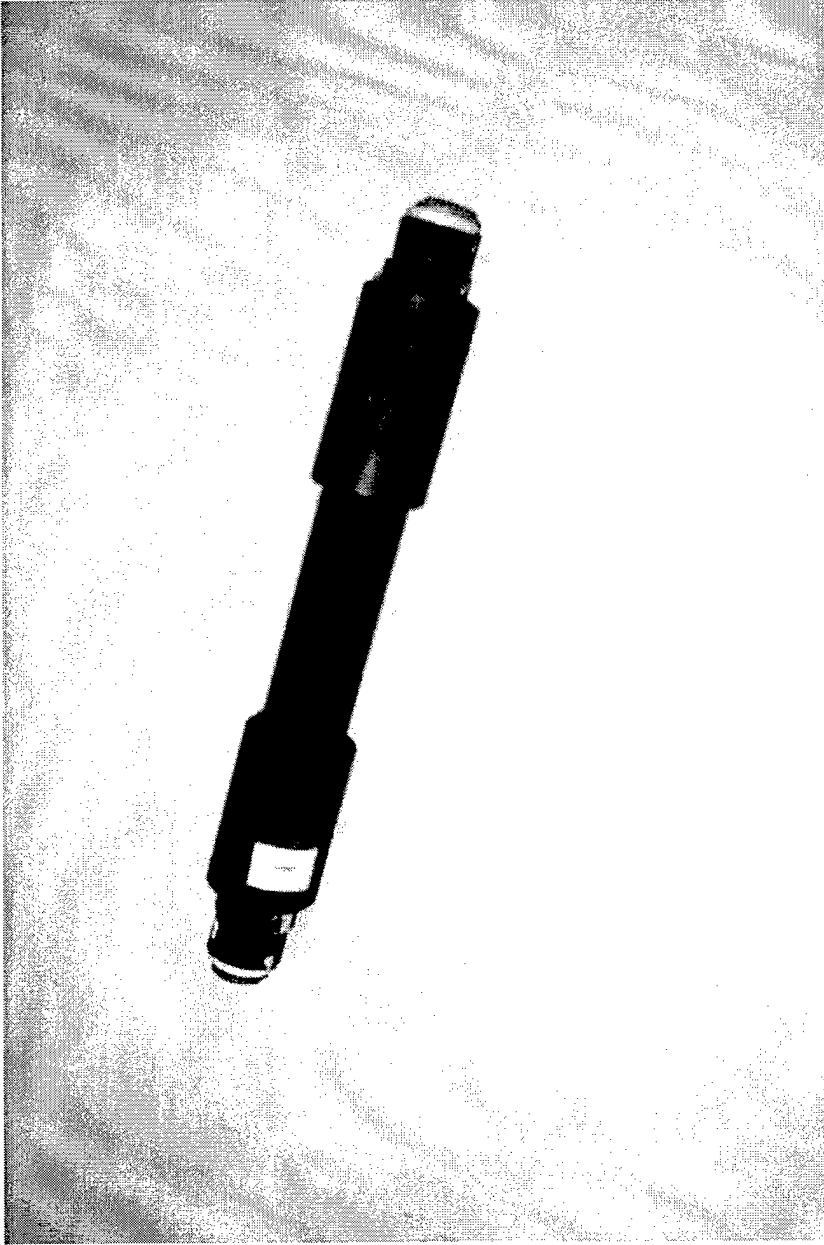

Figure 26: Reverse Bike Pump Prototype

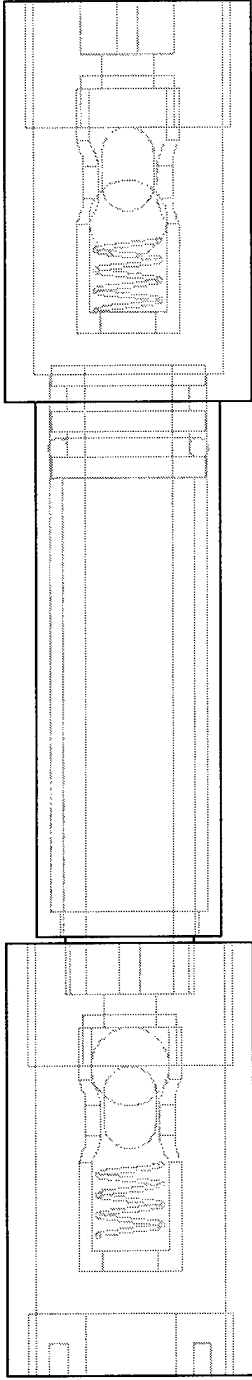

Figure 27: Unexploded Reverse Bike Pump Assembly

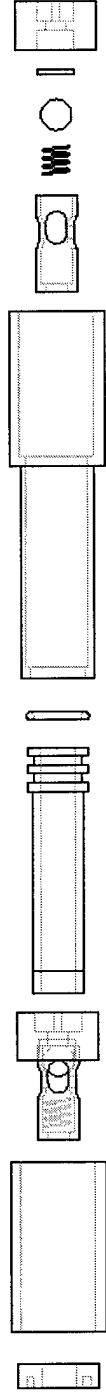
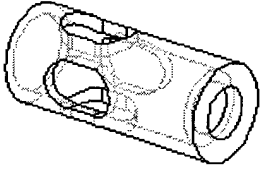

Figure 28: Exploded Reverse Bike Pump Assembly



Milled-Tube.PRT
10/9/88
Mat'l: Acrylic
Tolerances: x.xxx ± 0.001
Part No.: 1

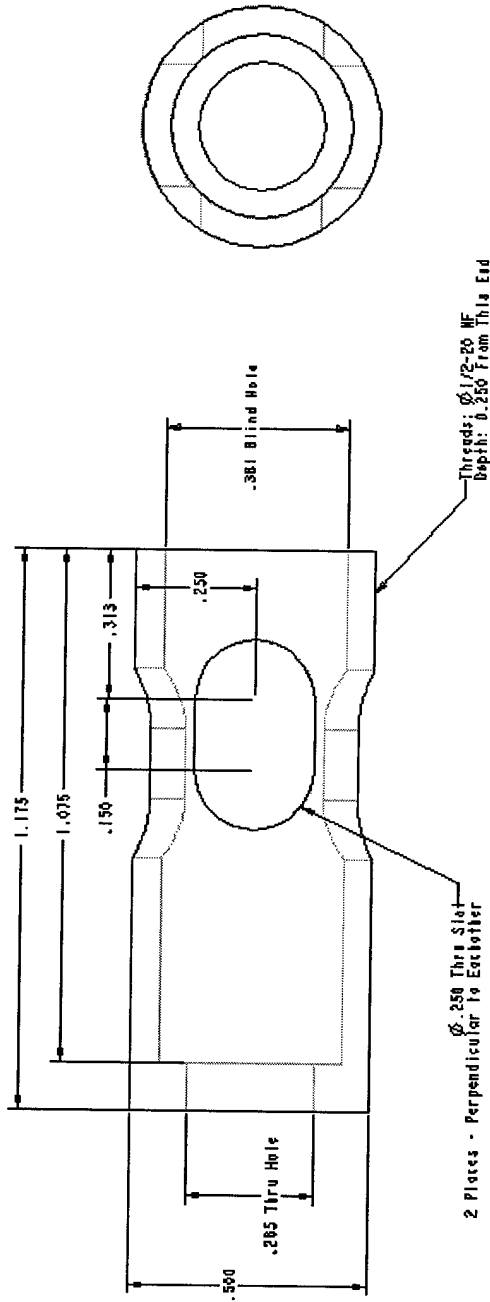
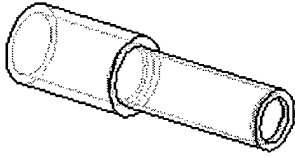

Figure 29: Engineering Drawing of the Milled-Tube



Lyigs-Tube.PRT
2/1/00
Mat: Aluminum
Tolerances: ± 0.001
Unless Otherwise Specified
Part No.: 2

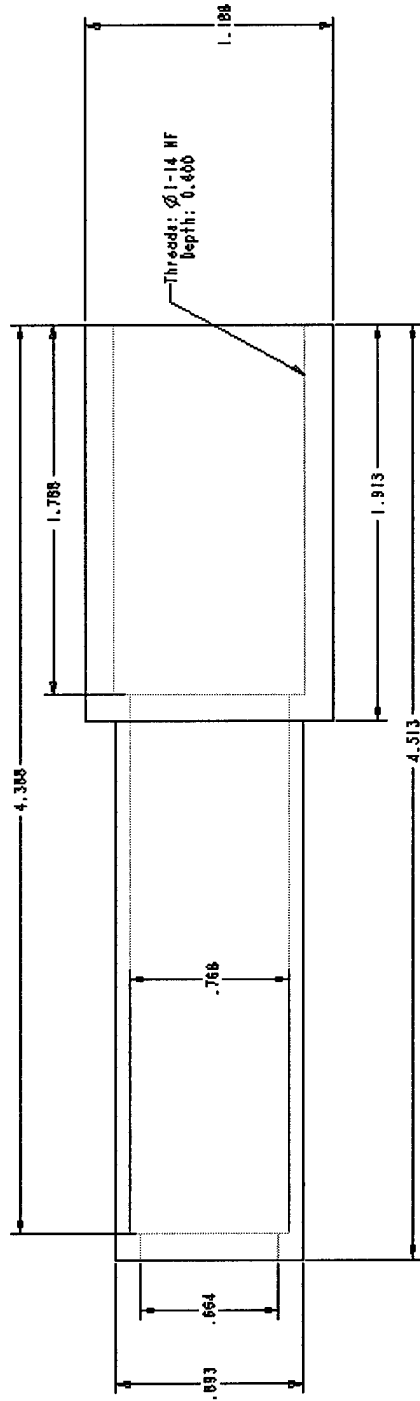
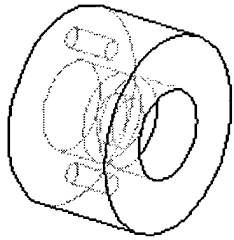
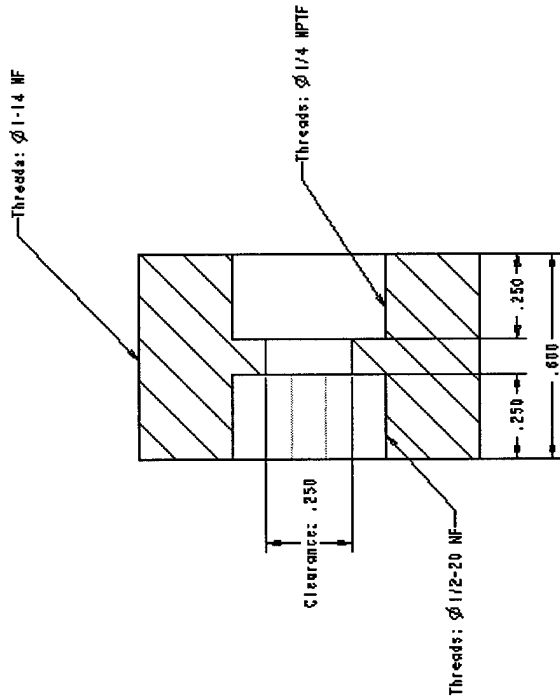
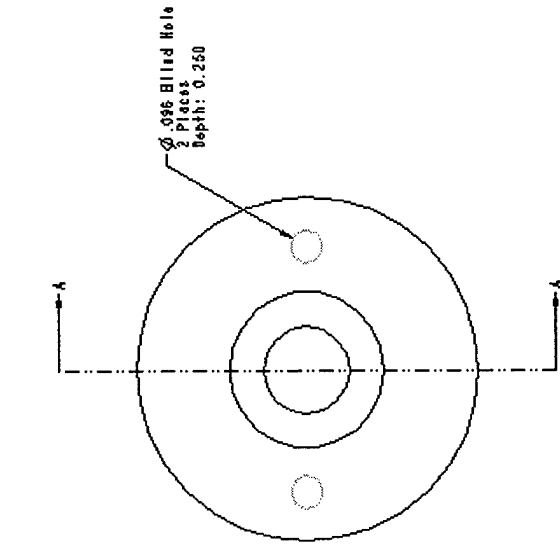

Figure 30: Engineering Drawing of the Housing Tube



Housing-A.PRT
 2/1/00
 Mat'l: Black Polycarbonate
 Tolerances: ± 0.001
 Unless Otherwise Specified
 Part No.: 3



SECTION A-A

Figure 31: Engineering Drawing of Housing-A

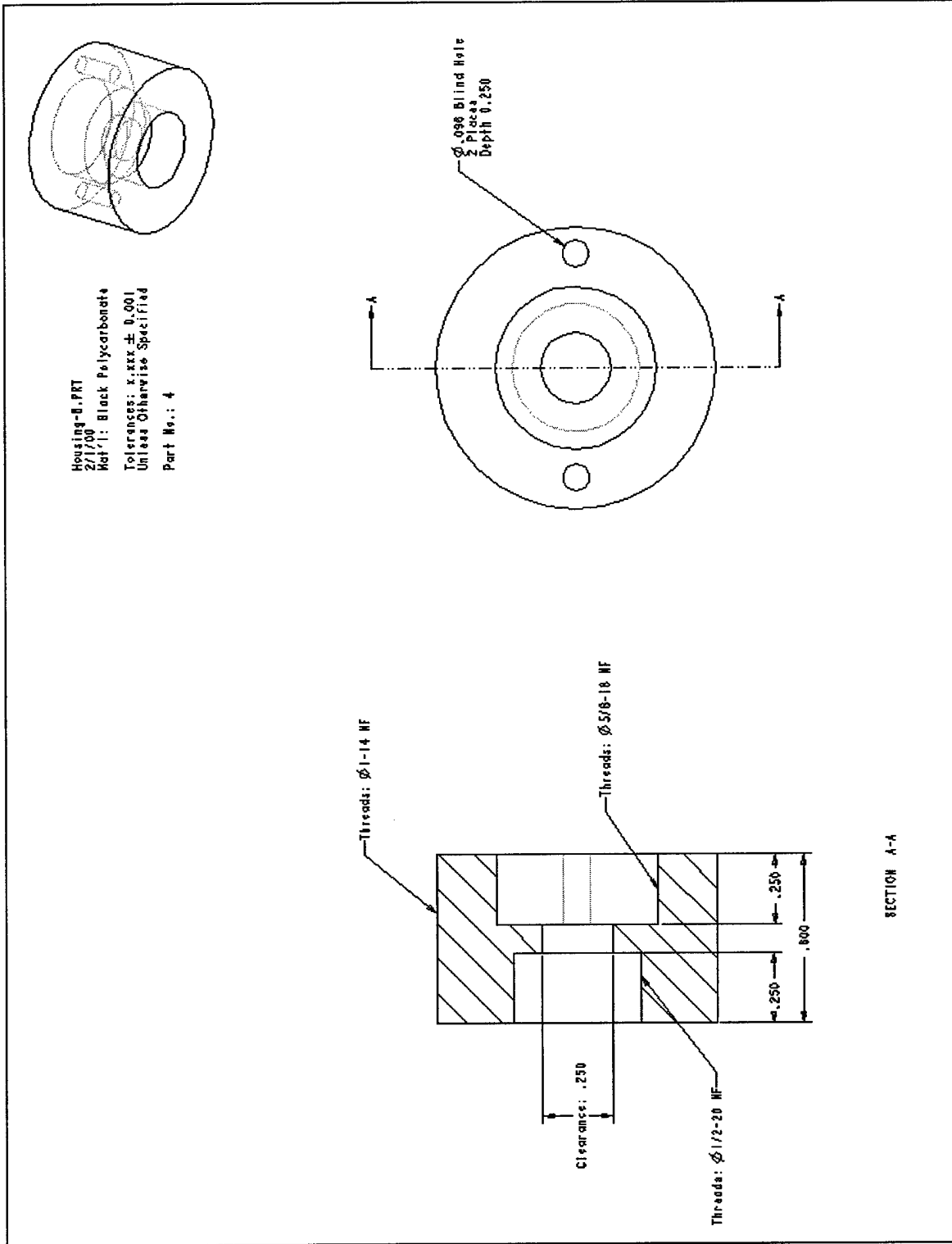

Figure 32: Engineering Drawing of Housing-B

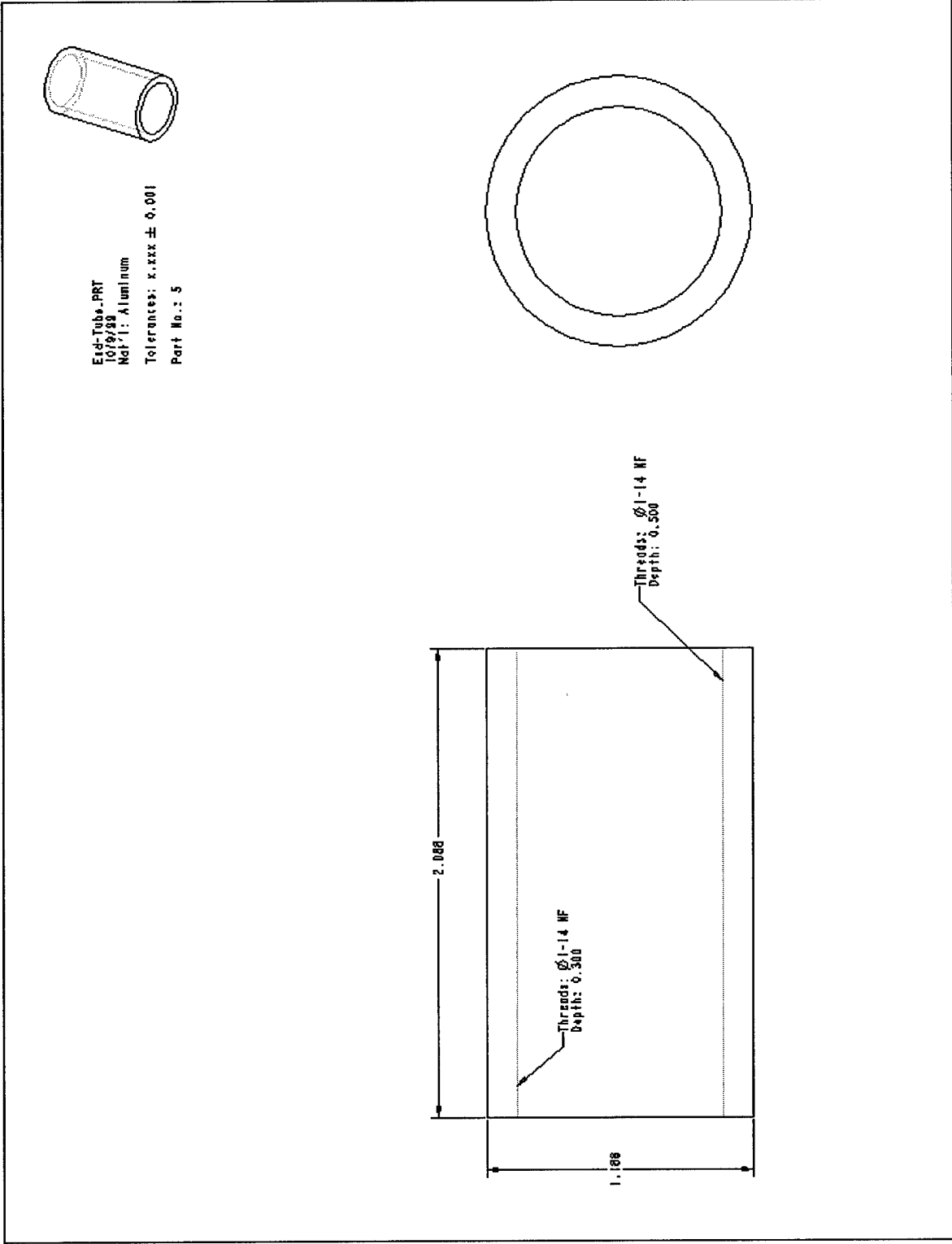
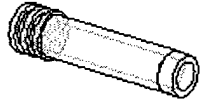

Figure 33: Engineering Drawing of the End-Tube



Inner-Tube, PRT
271500
Mat'l: Aluminum
Tolerances: ± 0.001
Unless Otherwise Specified
Part No.: B

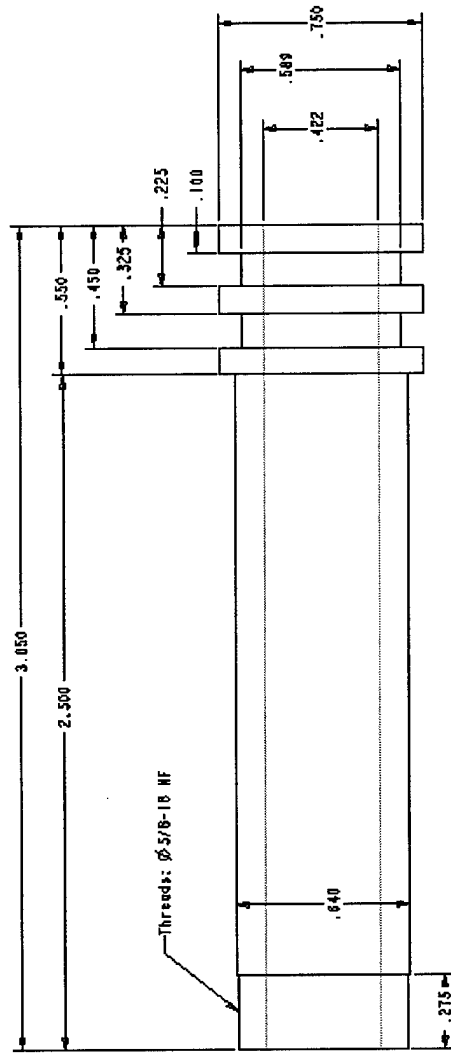

Figure 34: Engineering Drawing of the Piston Tube

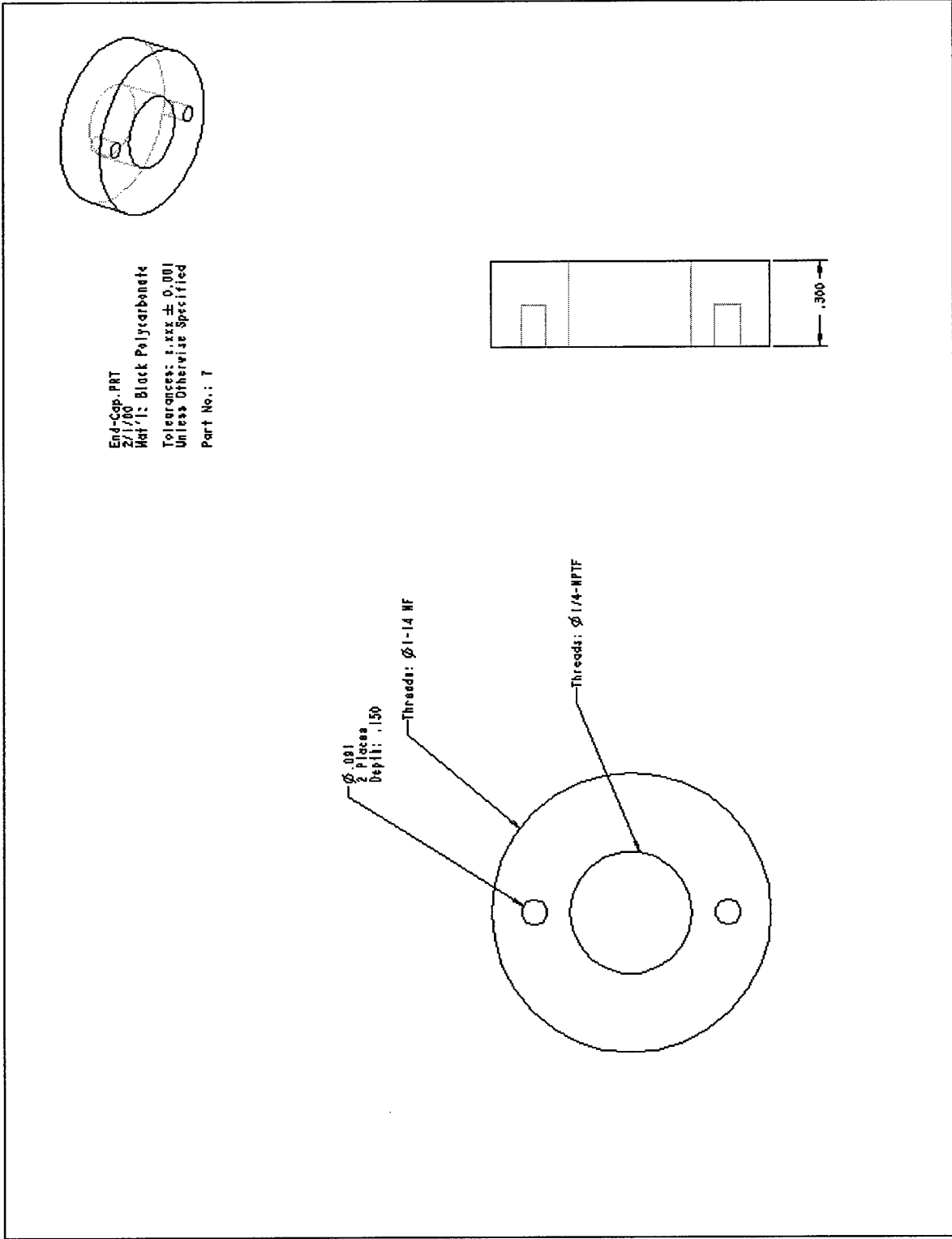

Figure 35: Engineering Drawing of the End-Cap

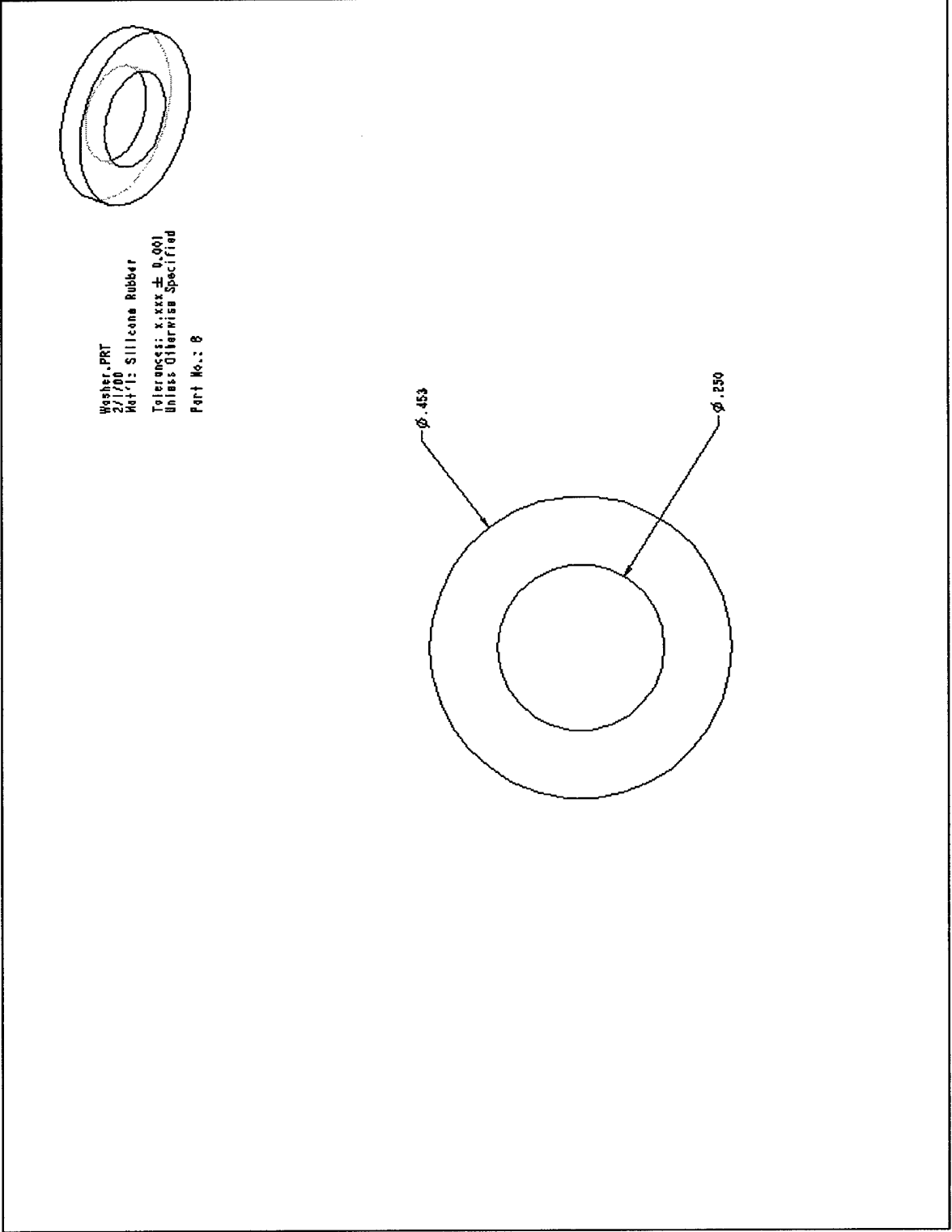

Figure 36: Engineering Drawing of the Washer

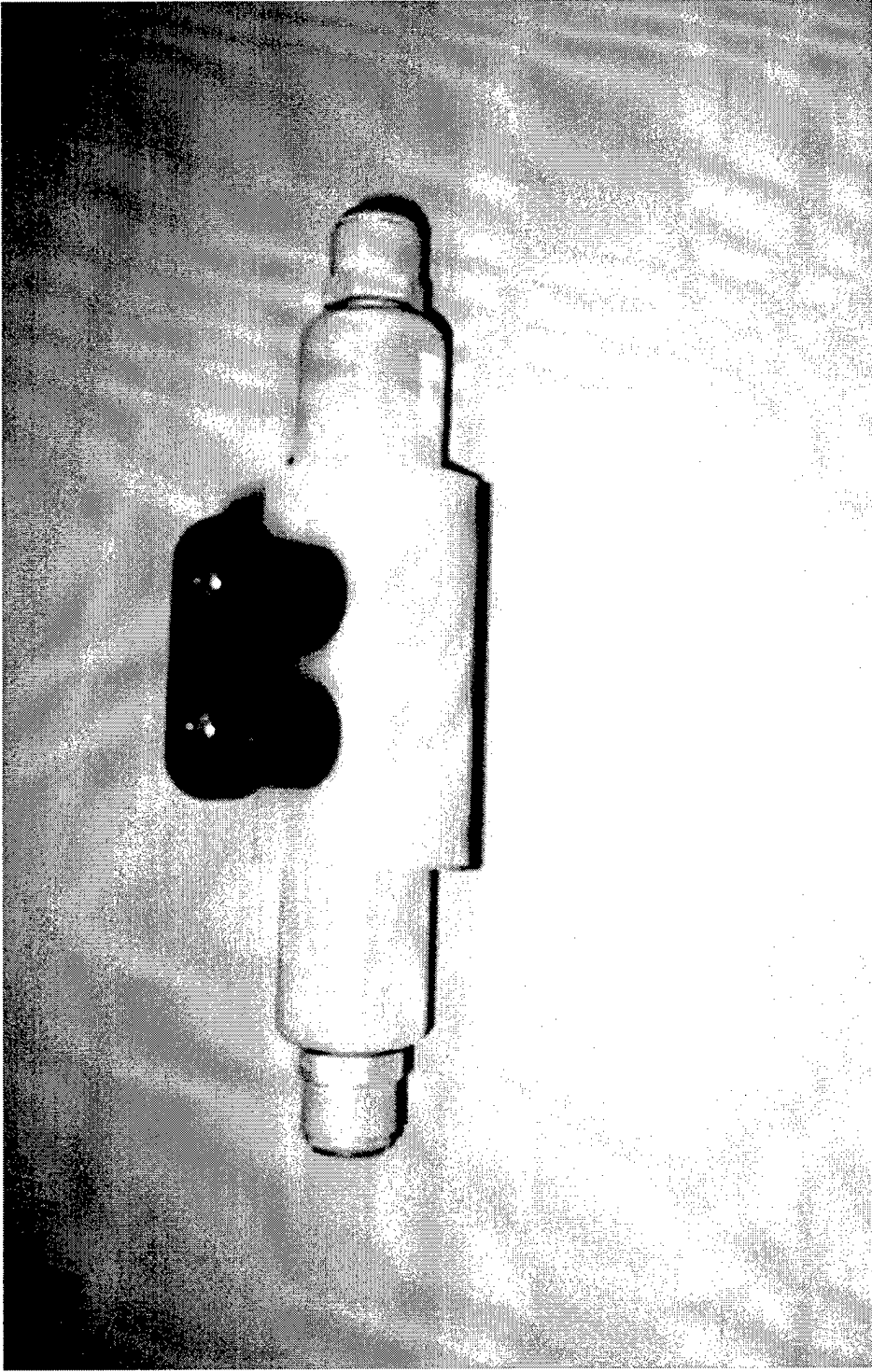

Figure 37: Double Piston Assembly Prototype

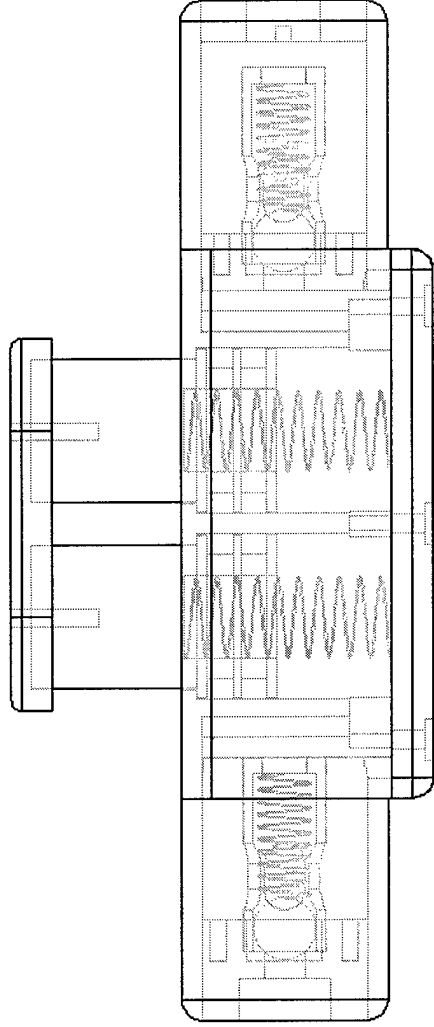

Figure 38: Unexploded View of the Double Piston Assembly

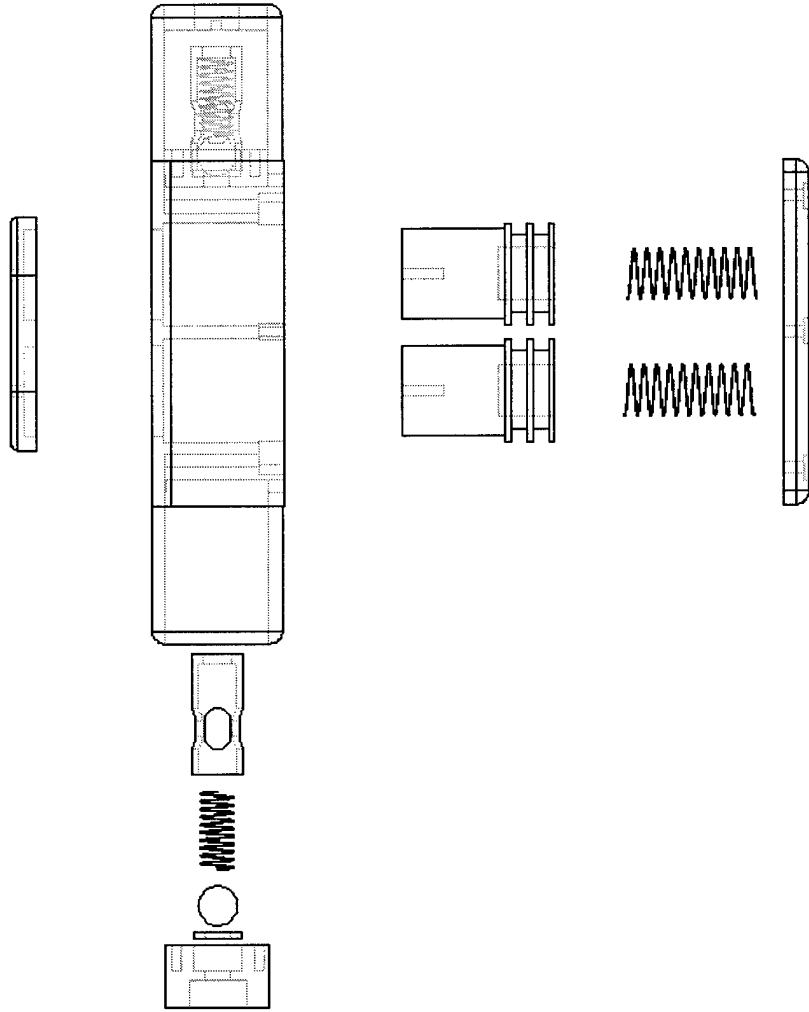

Figure 39: Exploded View of the Double Piston Assembly

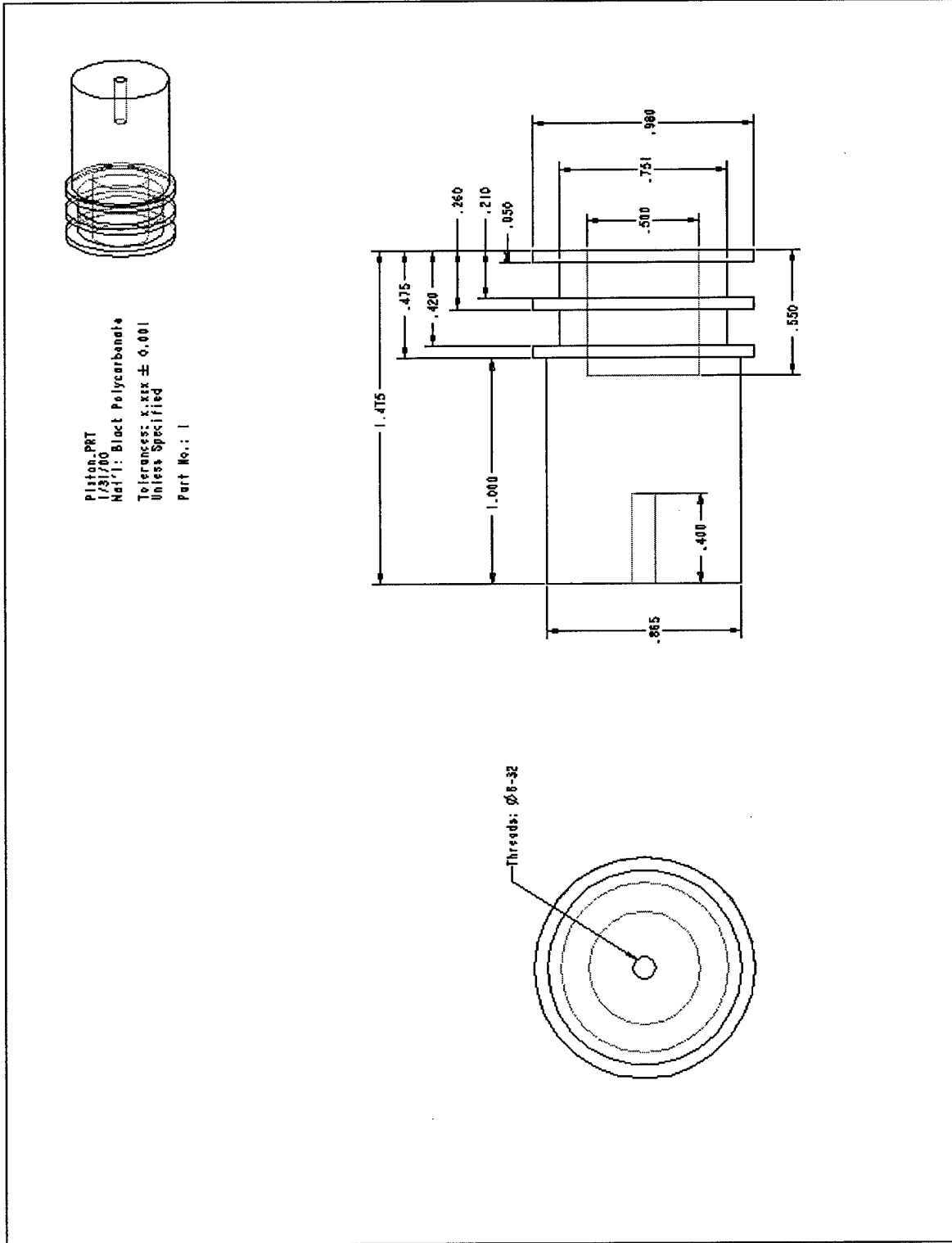

Figure 40: Engineering Drawing of the Piston

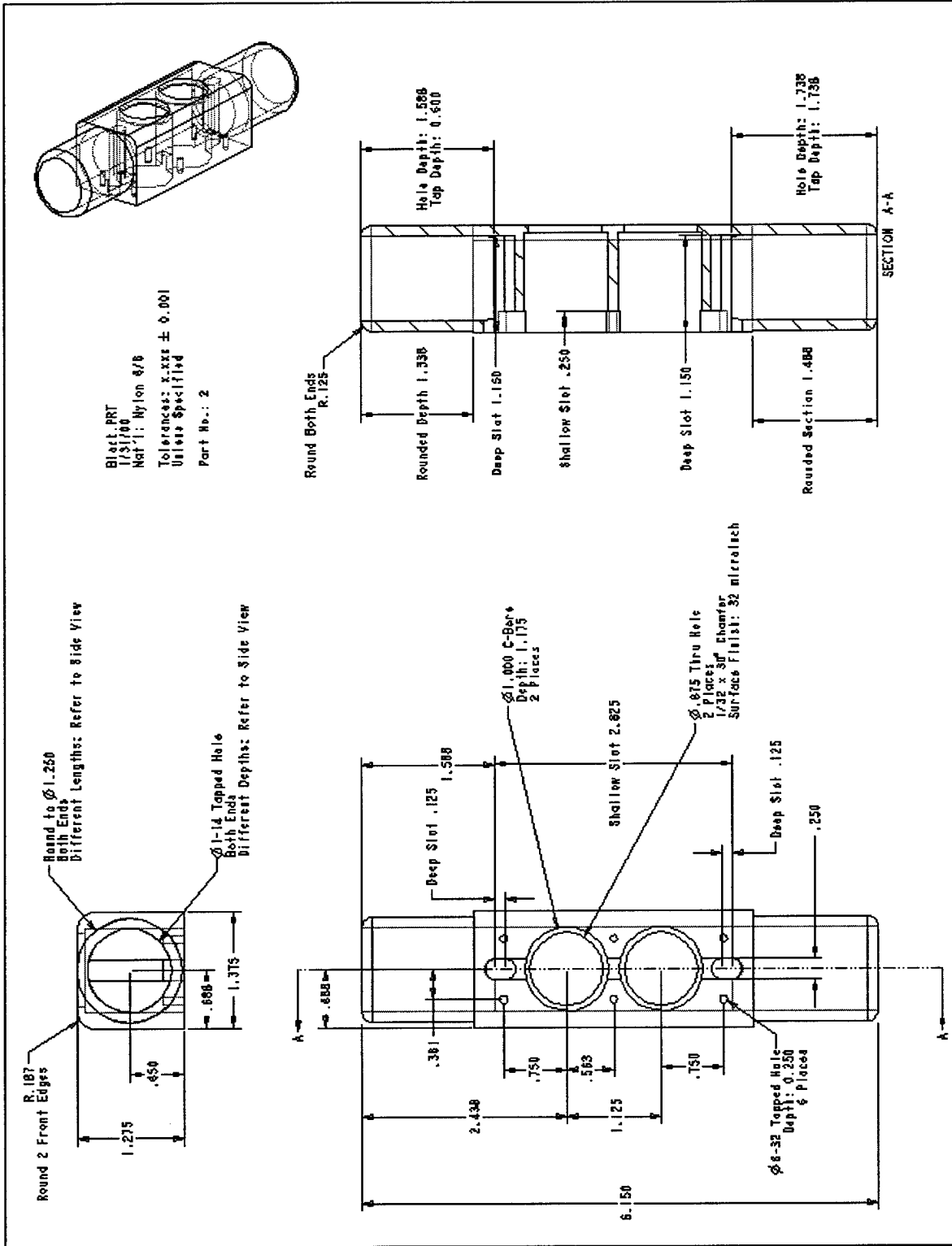
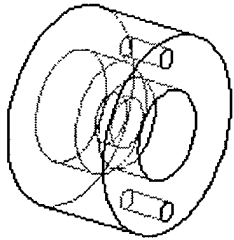
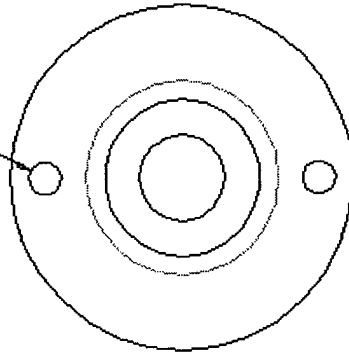

Figure 41: Engineering Drawing of the Housing Block



Housing-A, PRT
1/23/00
Mat: 1: Black Polycarbonate
Tolerances: X:xxx ± 0.001
Unless Specified
Part No.: 3

Ø .006 Blind Hole
2 Places
Depth 0.250



Threads: Ø 1-14 NF

Threads: Ø 1/4 NF TF

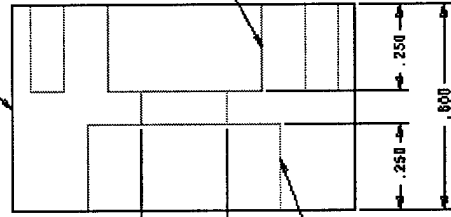

Clearance: .250

Threads: Ø 1/2-20 NF

Figure 42: Engineering Drawing of Housing-A

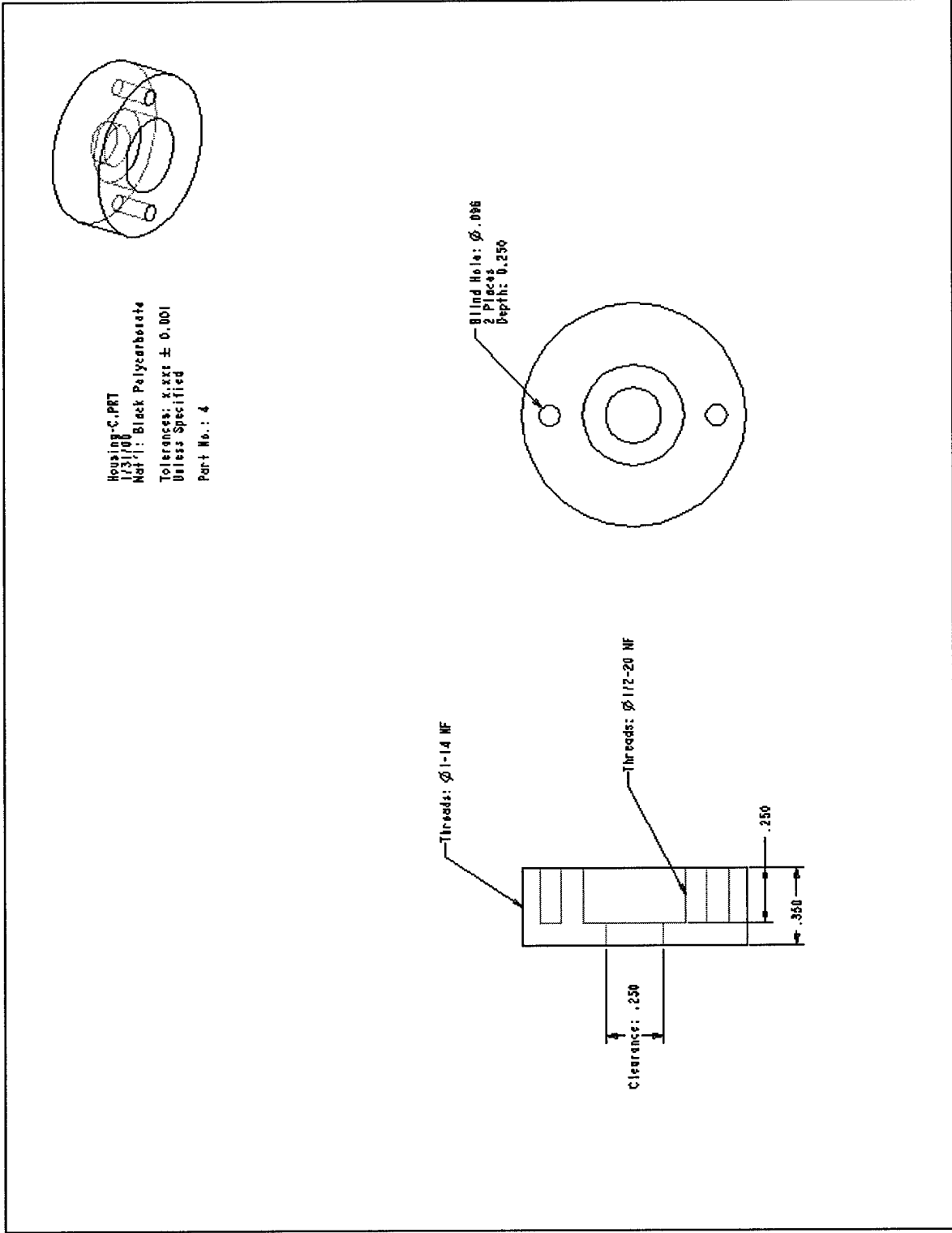
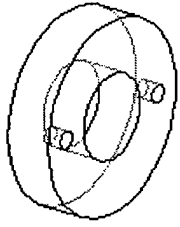

Figure 43: Engineering Drawing of Housing-C



Housing-0.PRT
1/31/99
Mat'l: Elect Polycarbonate
Tolerances: x.xxx ± 0.001
Unless Otherwise Specified
Part No.: 5

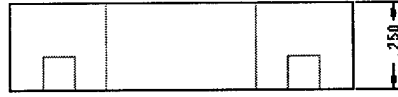
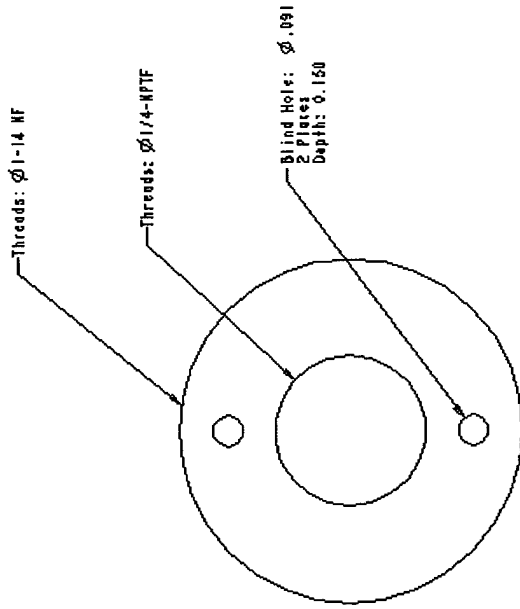

Figure 44: Engineering Drawing of Housing-D

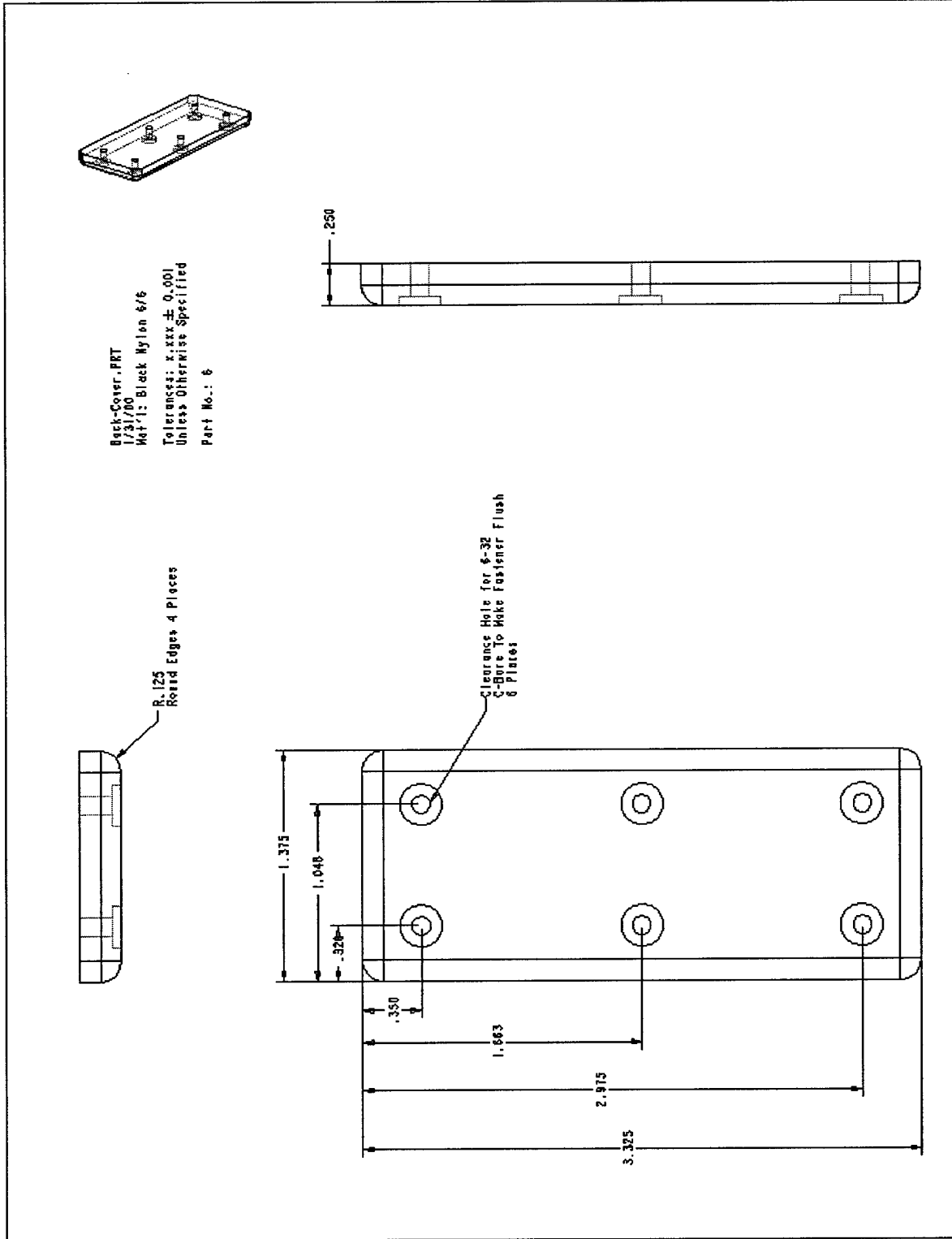
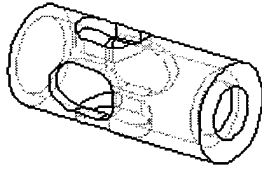
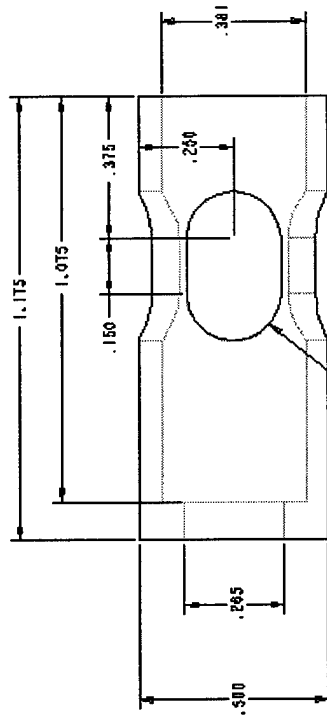
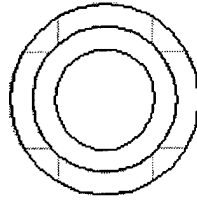

Figure 45: Engineering Drawing of the Back Cover



Milled-Tube.PRT
1/31/00
Mat'l: Acrylic
Tolerances: x.xxx ± .001
Unless Otherwise Specified
Part No.: 7



2 Places - Perpendicular to Each Other

Threads: $\varnothing 1/2-20$ NF
Length: 0.250 From This End

Figure 46: Engineering Drawing of the Milled Tube

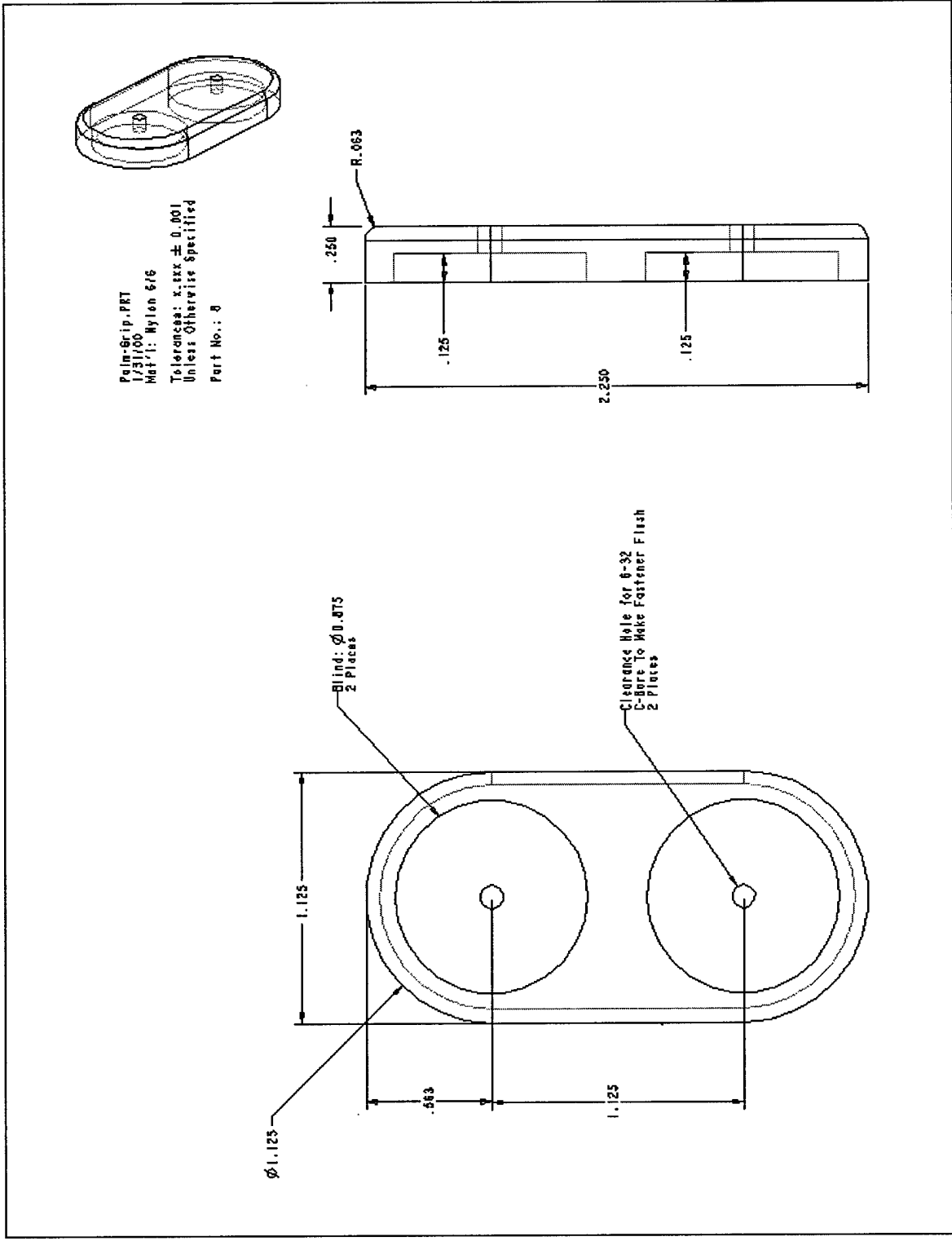

Figure 47: Engineering Drawing of the Palm Plate

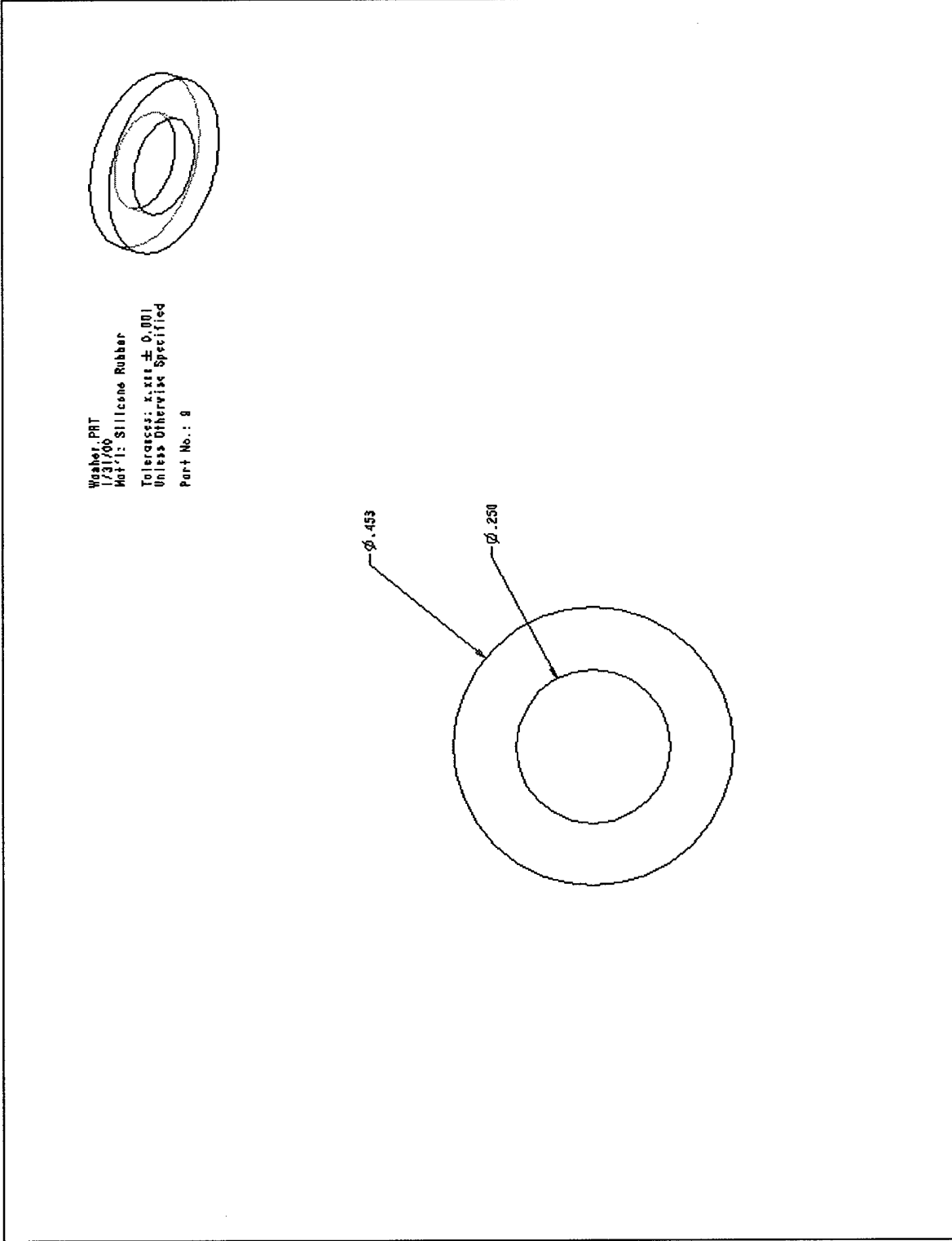

Figure 48: Engineering Drawing of the Washer

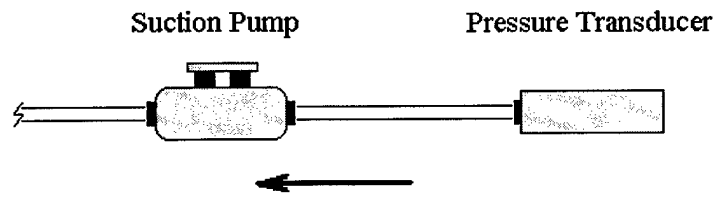

Figure 49: "Dry" Pressure Test Setup

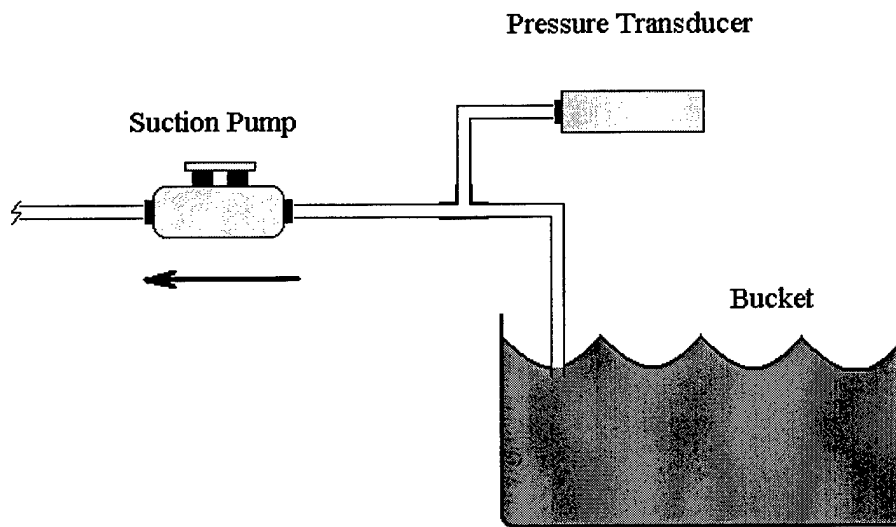

Figure 50: "Wet" Pressure Test Setup

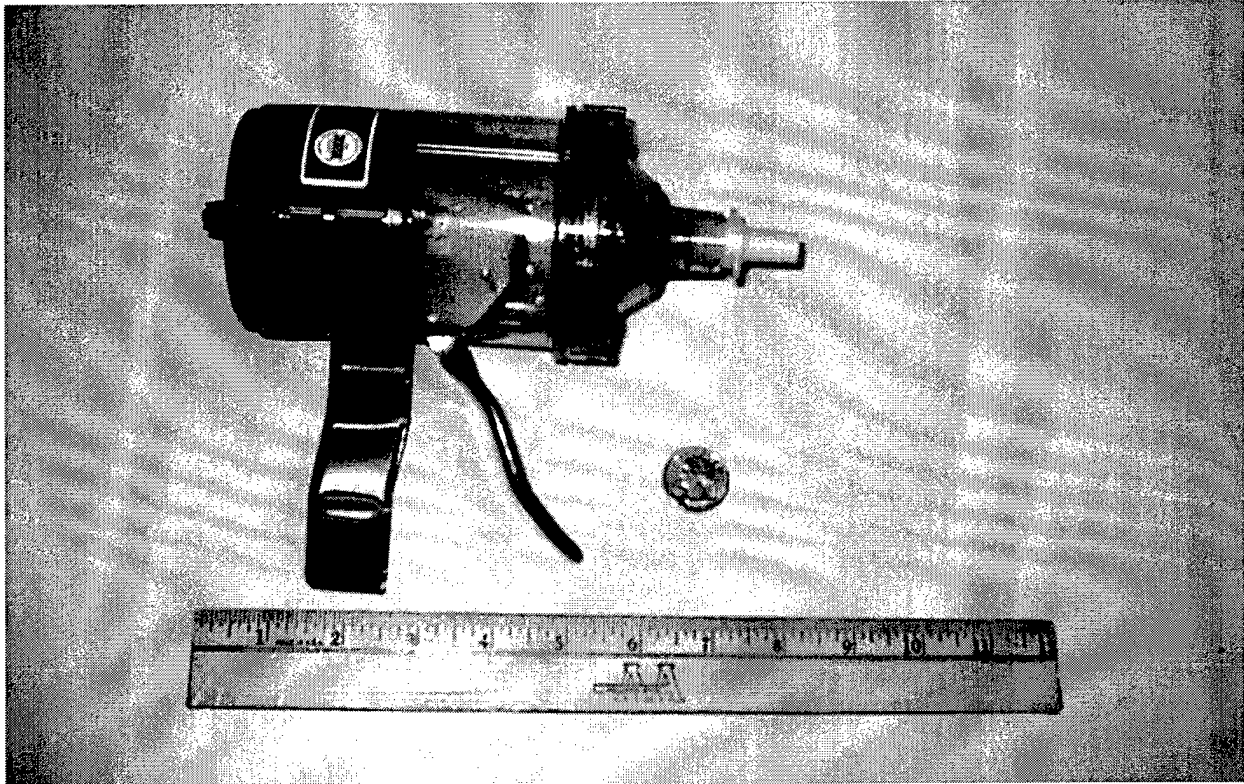

Figure 51: Photograph of the Vitalograph

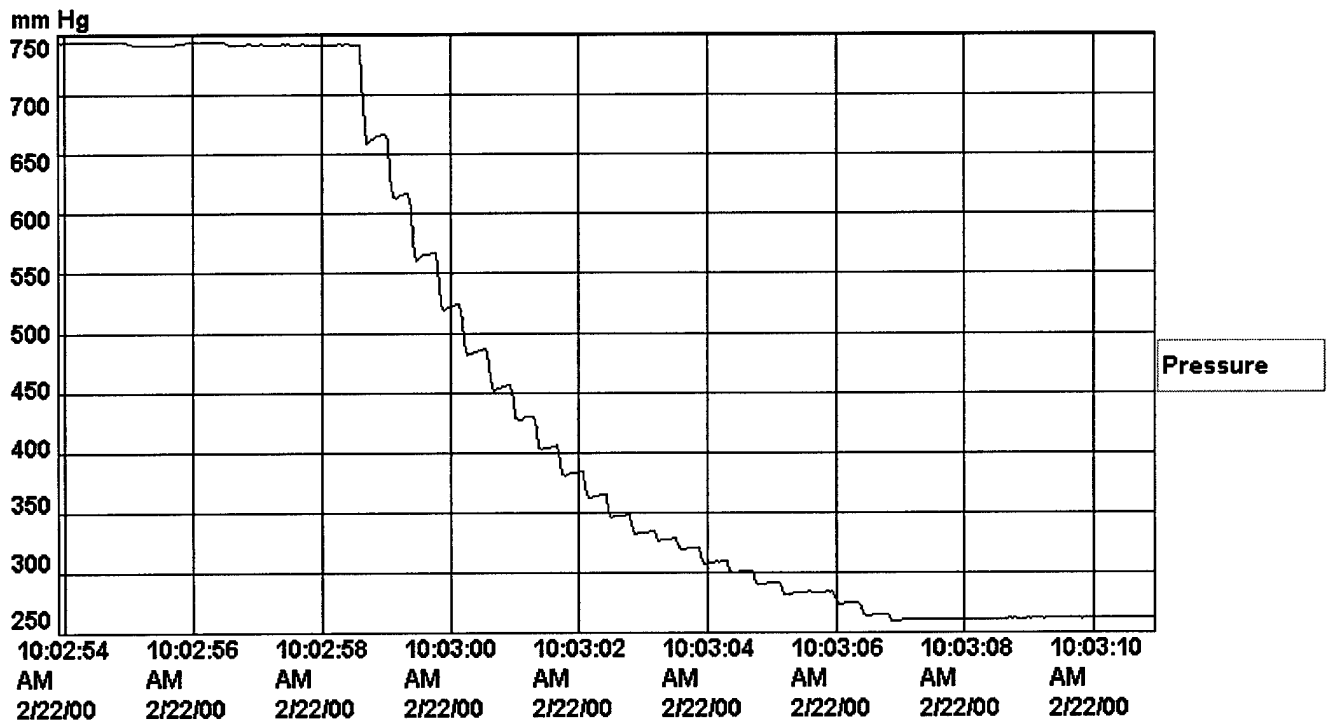

Figure 52: Vitalograph Pressure Test with Air

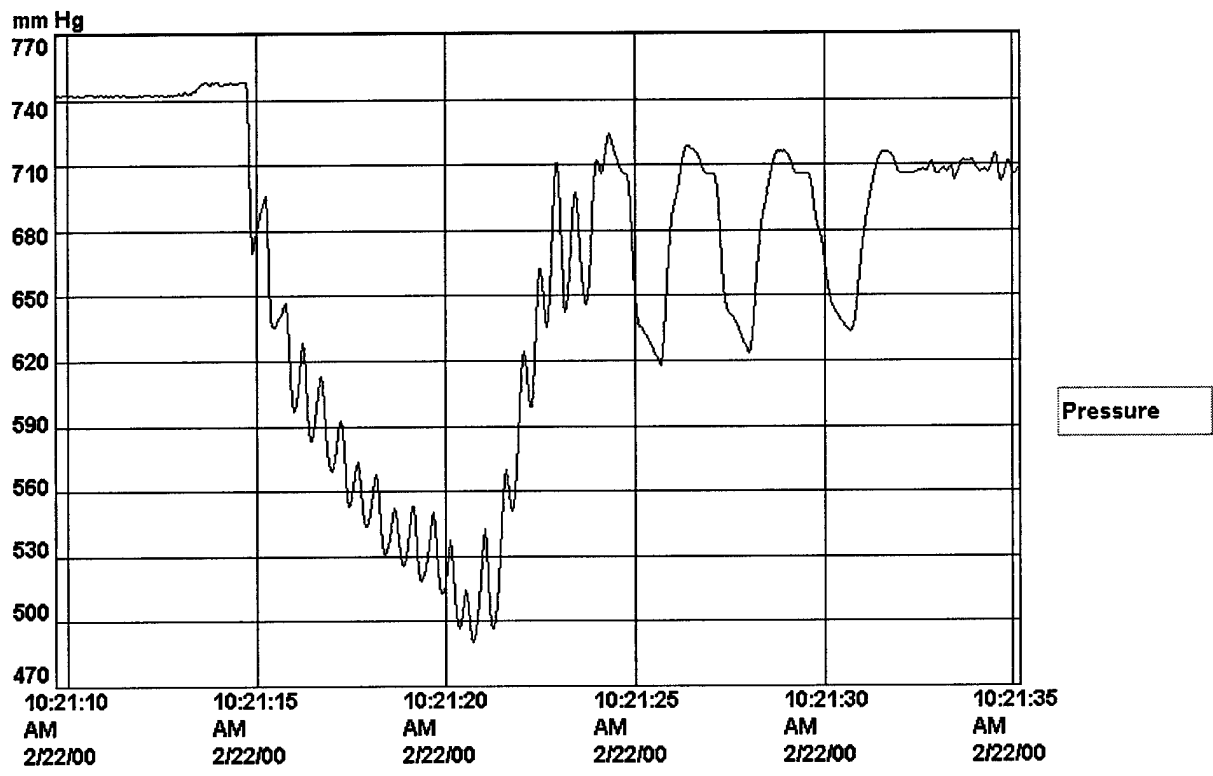

Figure 53: Vitalograph Pressure Test with Water

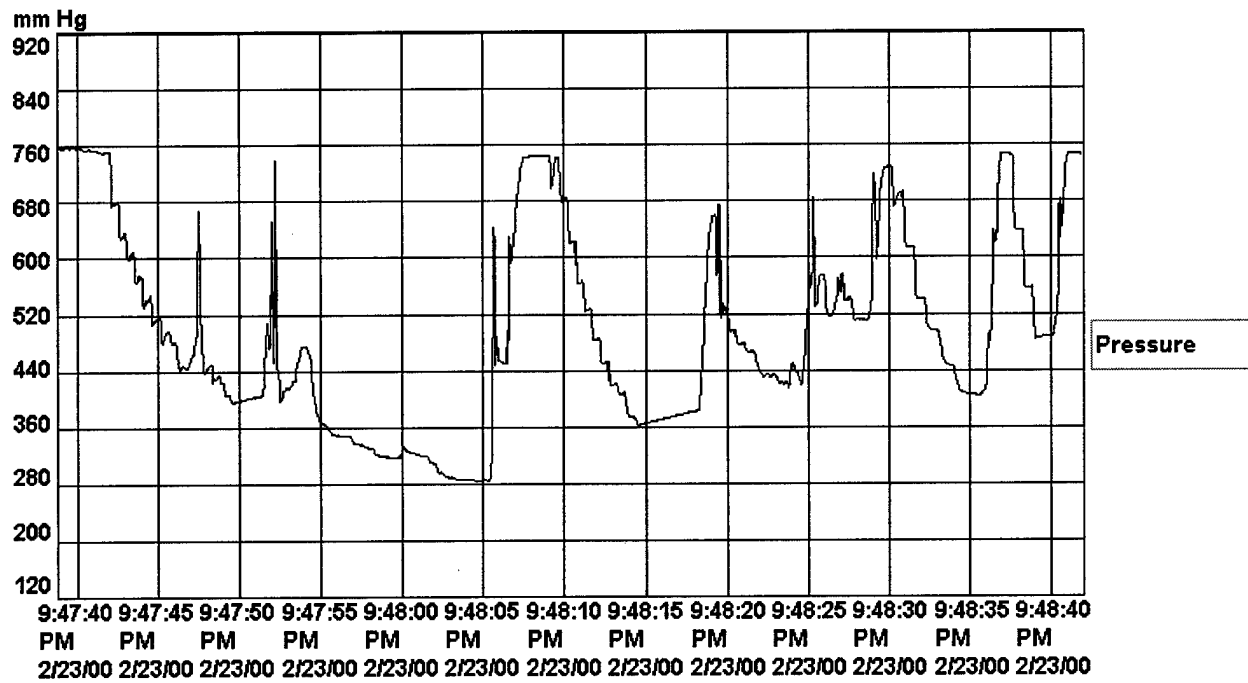

Figure 54: Vitalograph Pressure Test with Soup

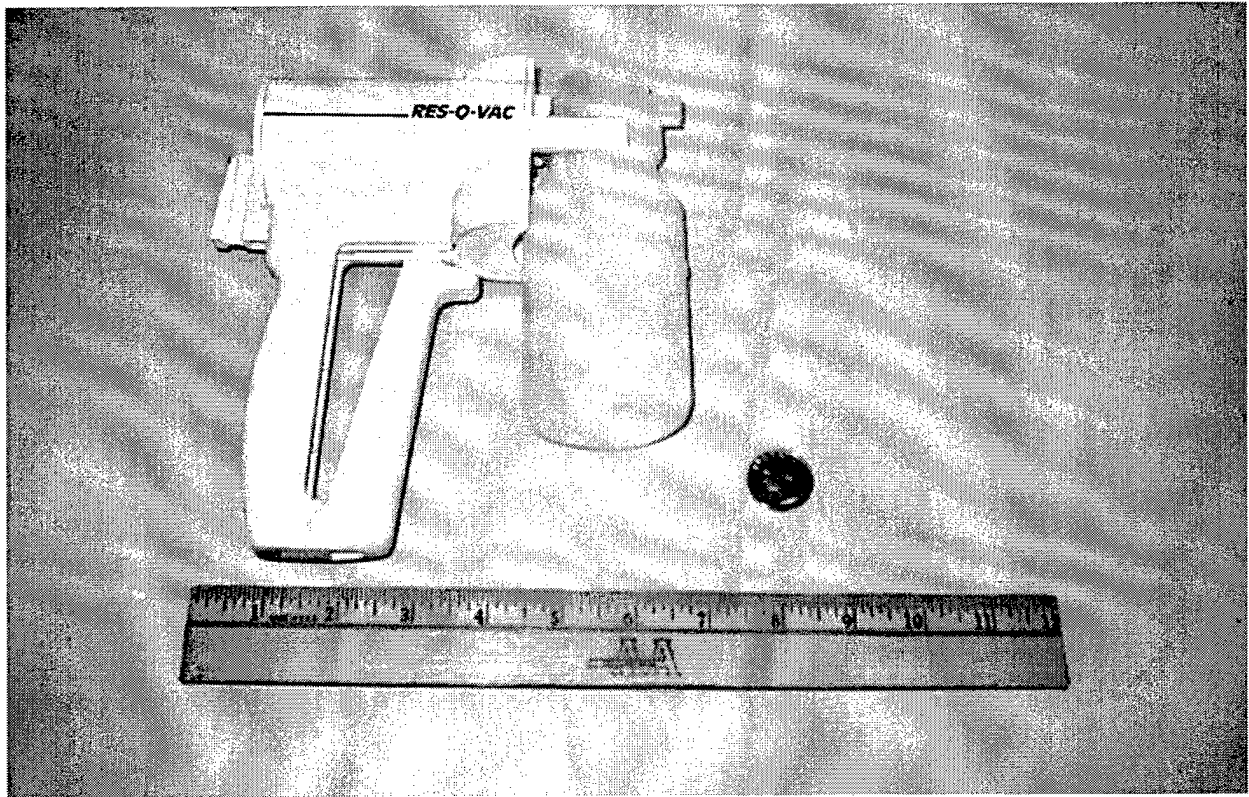

Figure 55: Photograph of the Res-Q-Vac

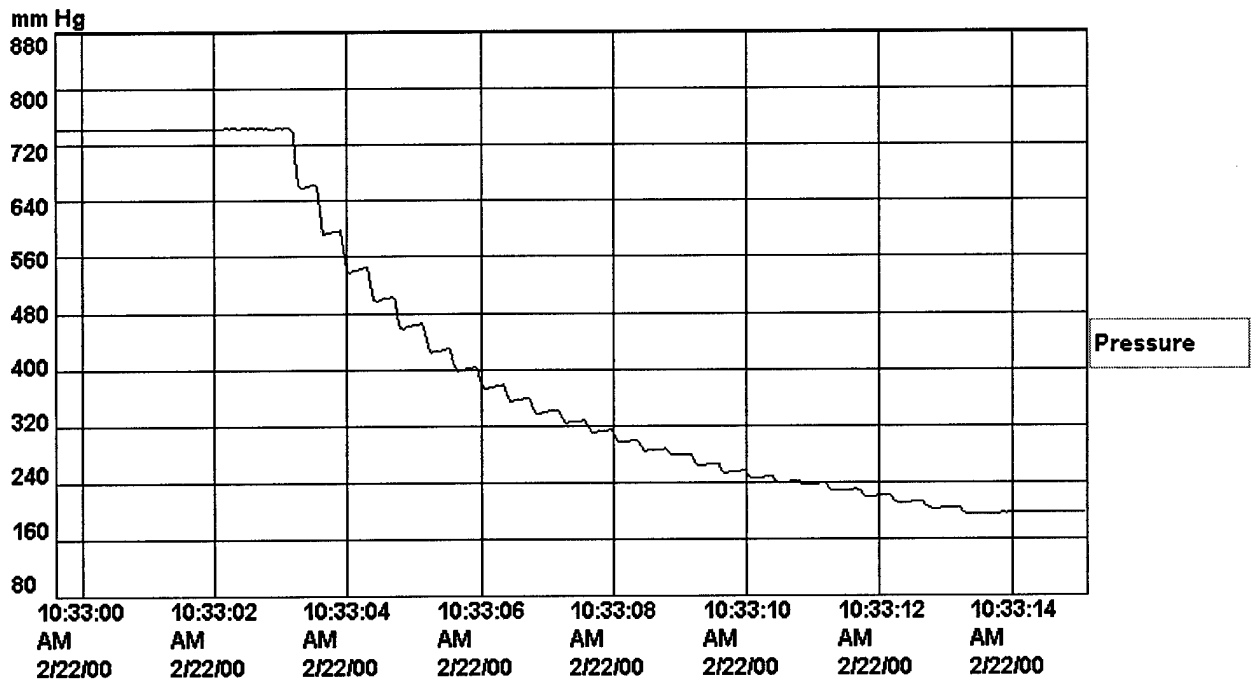

Figure 56: Res-Q-Vac Pressure Test with Air

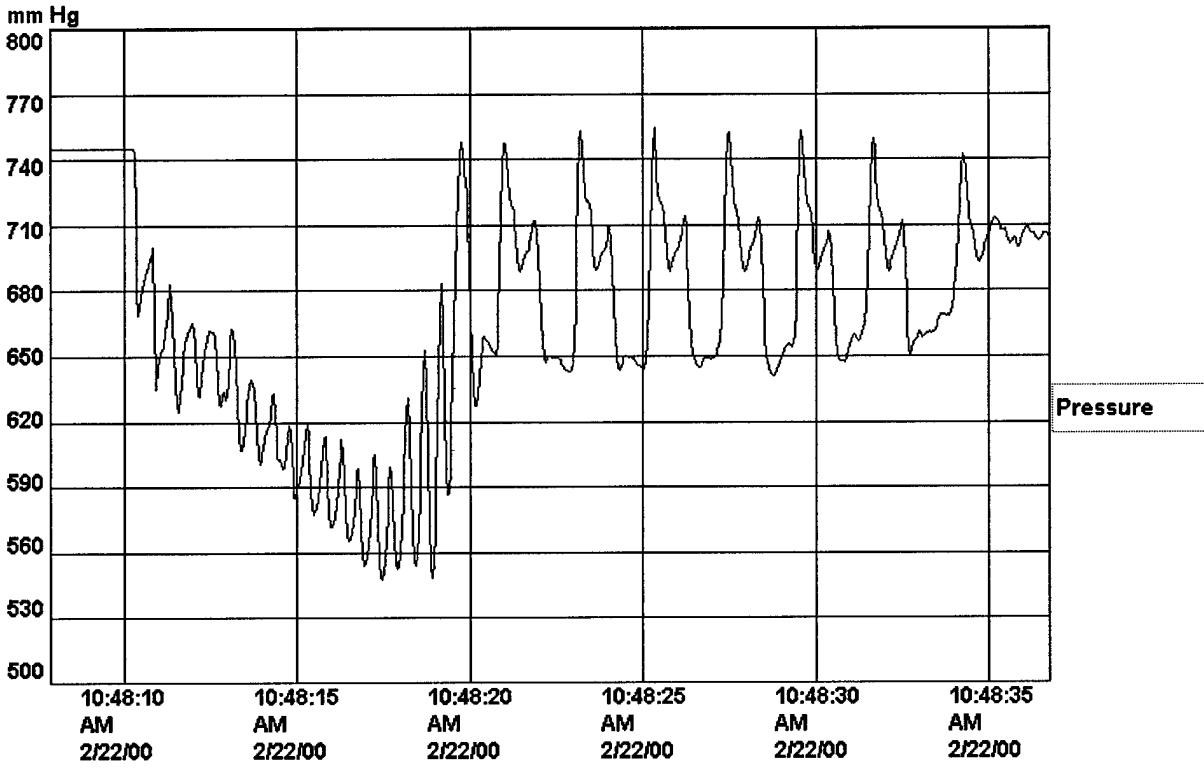

Figure 57: Res-Q-Vac Pressure Test with Water

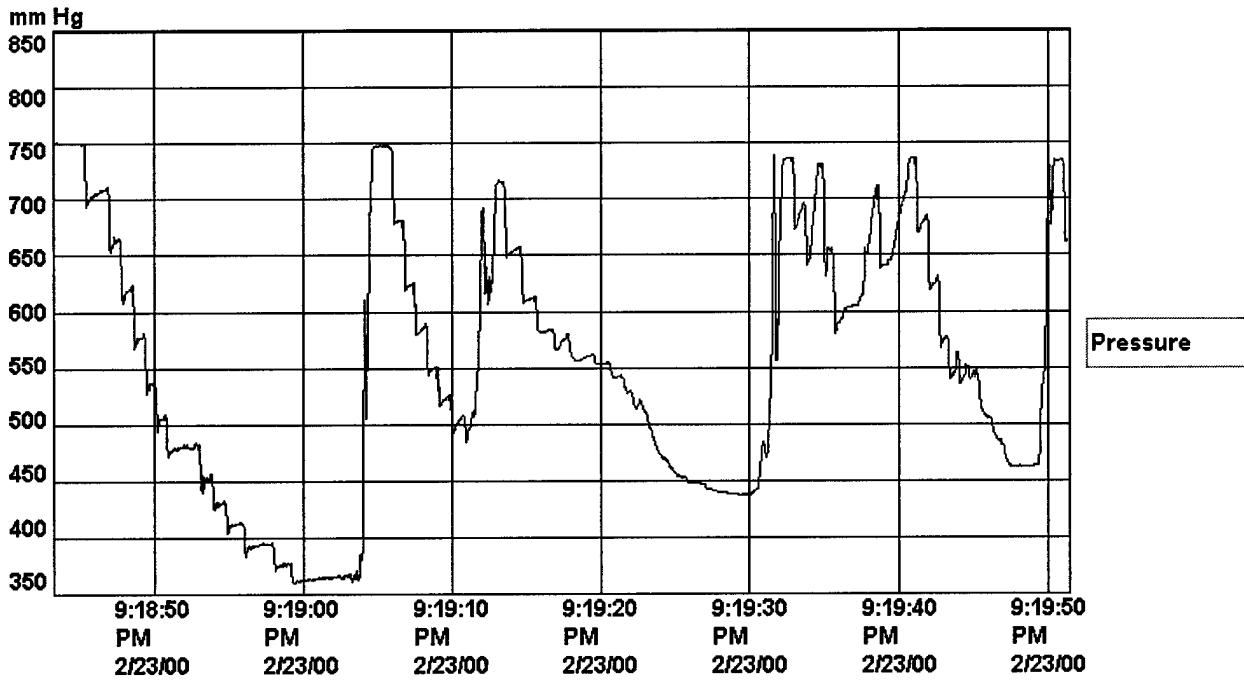

Figure 58: Res-Q-Vac Pressure Test with Soup

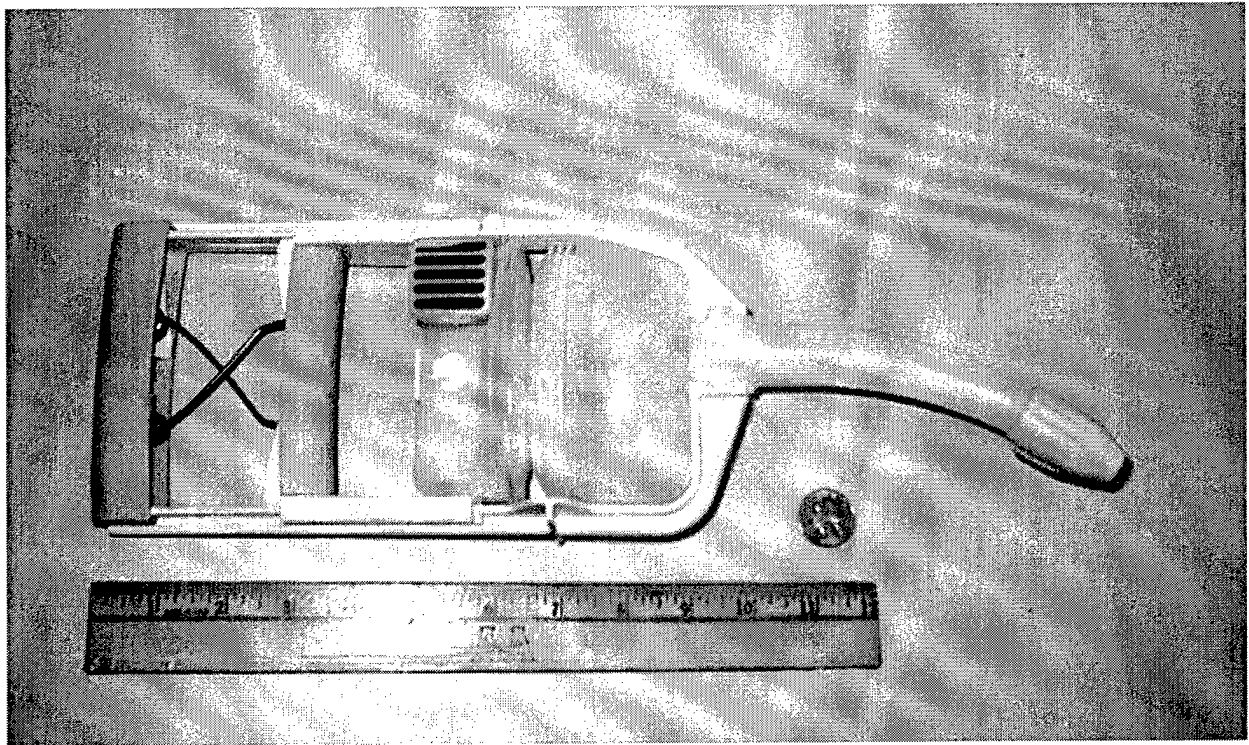

Figure 59: Photograph of the V-Vac

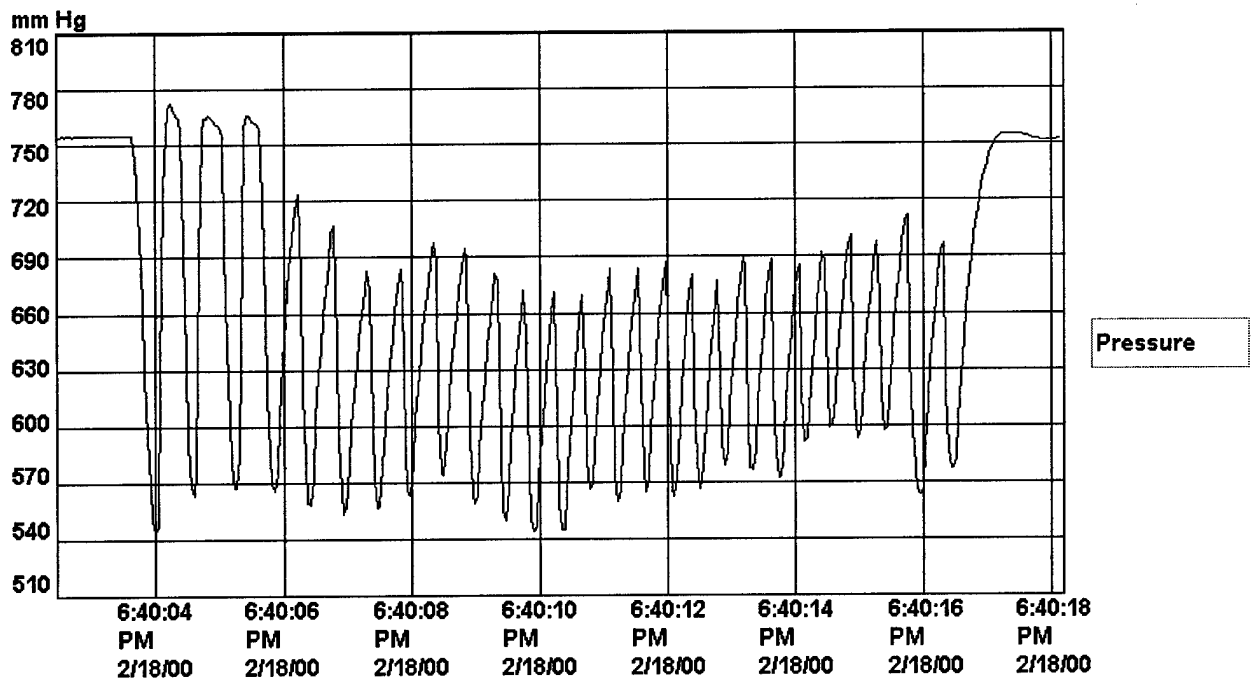

Figure 60: V-Vac Pressure Test with Air

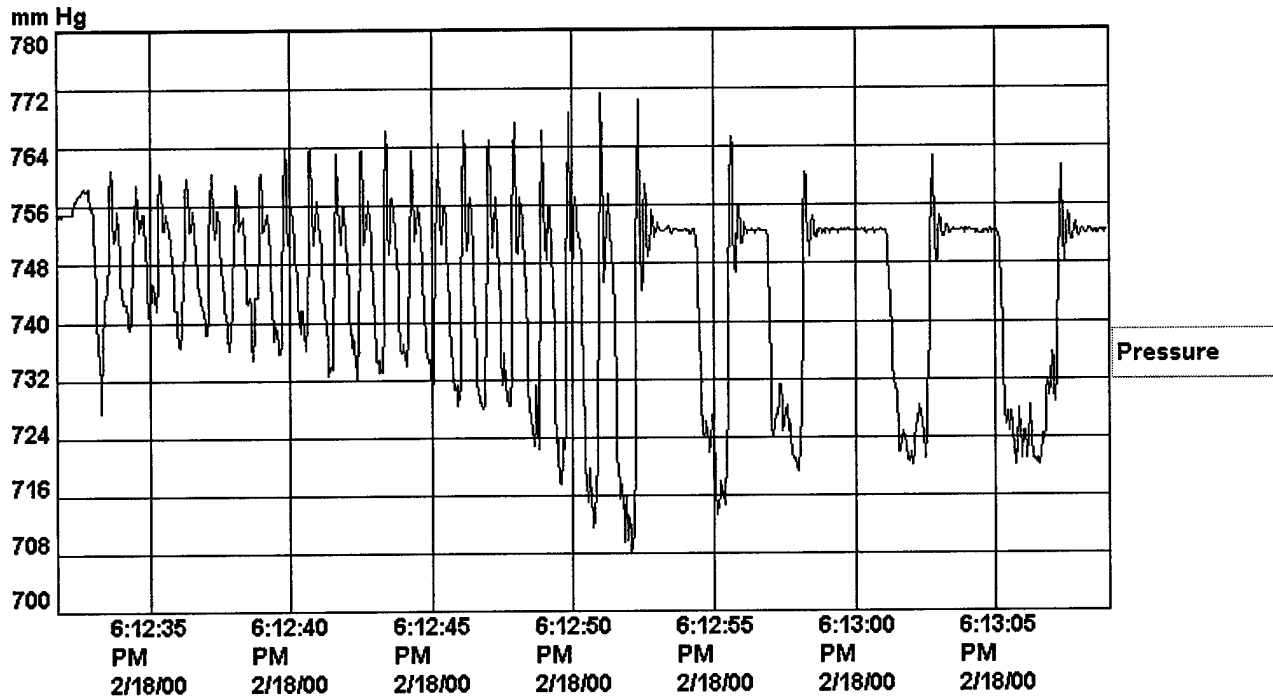

Figure 61: V-Vac Pressure Test with Water

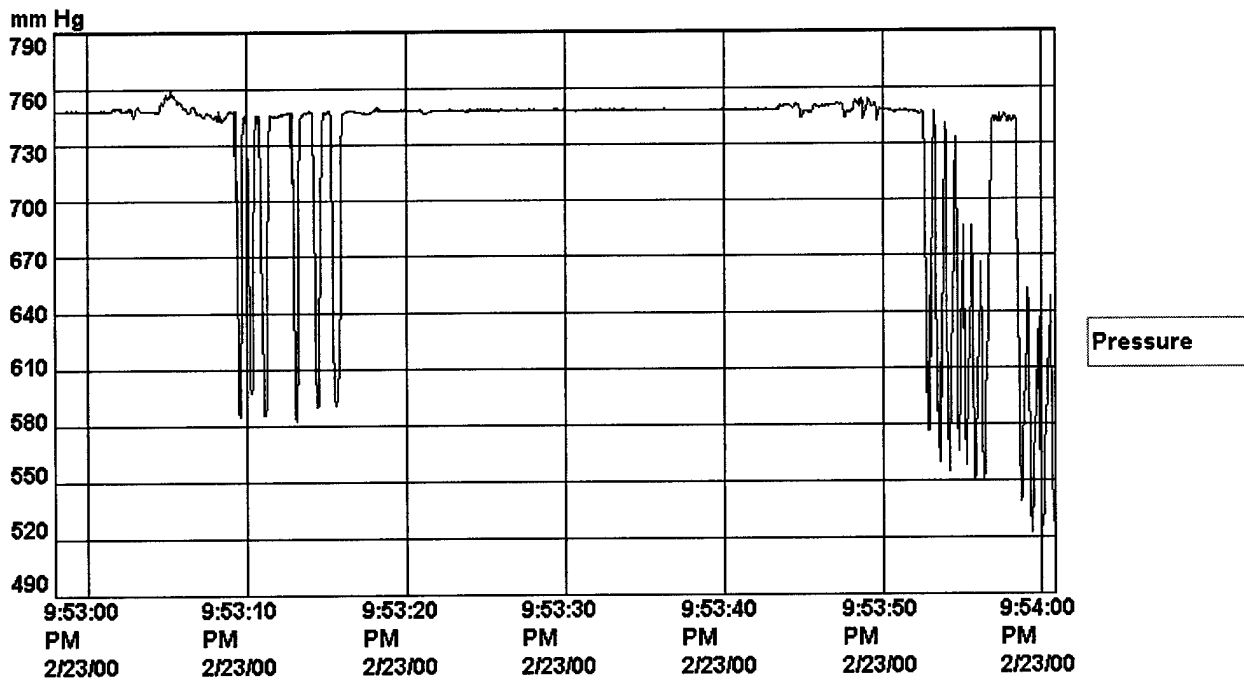

Figure 62: V-Vac Pressure Test with Soup

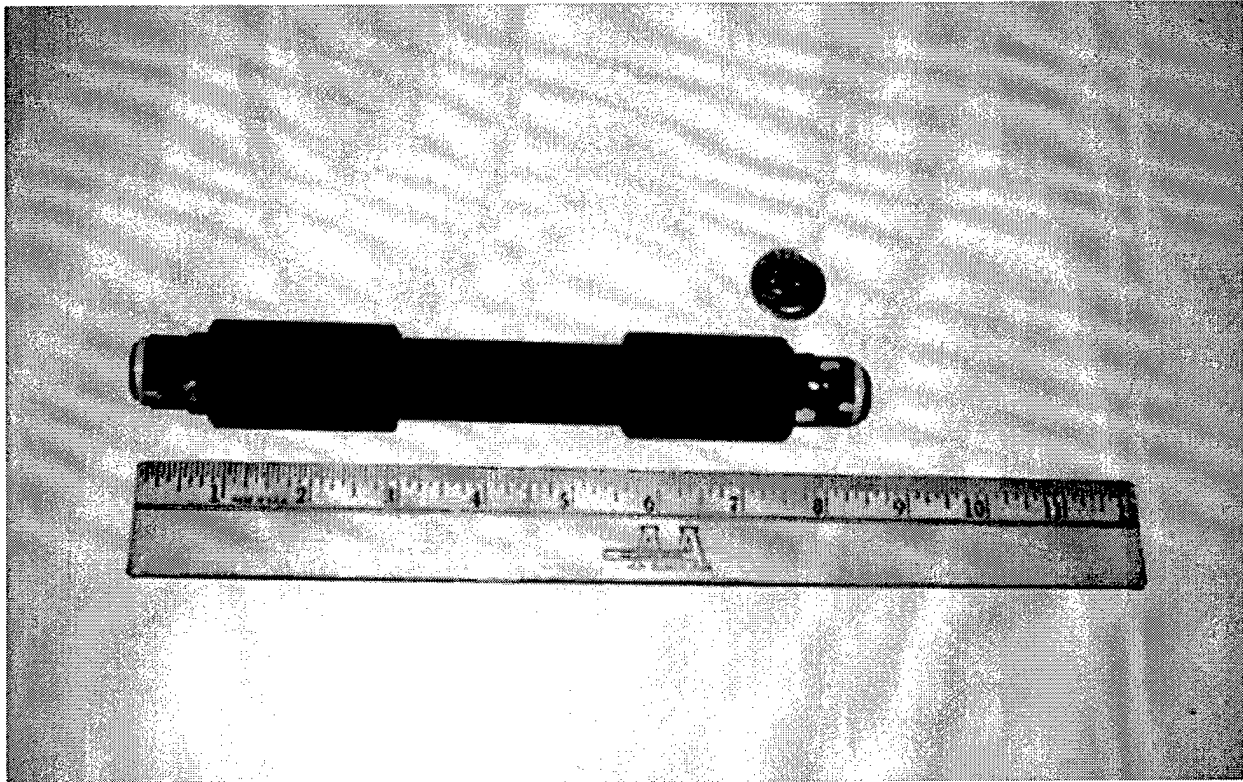

Figure 63: Photograph of the Reverse Bike Pump

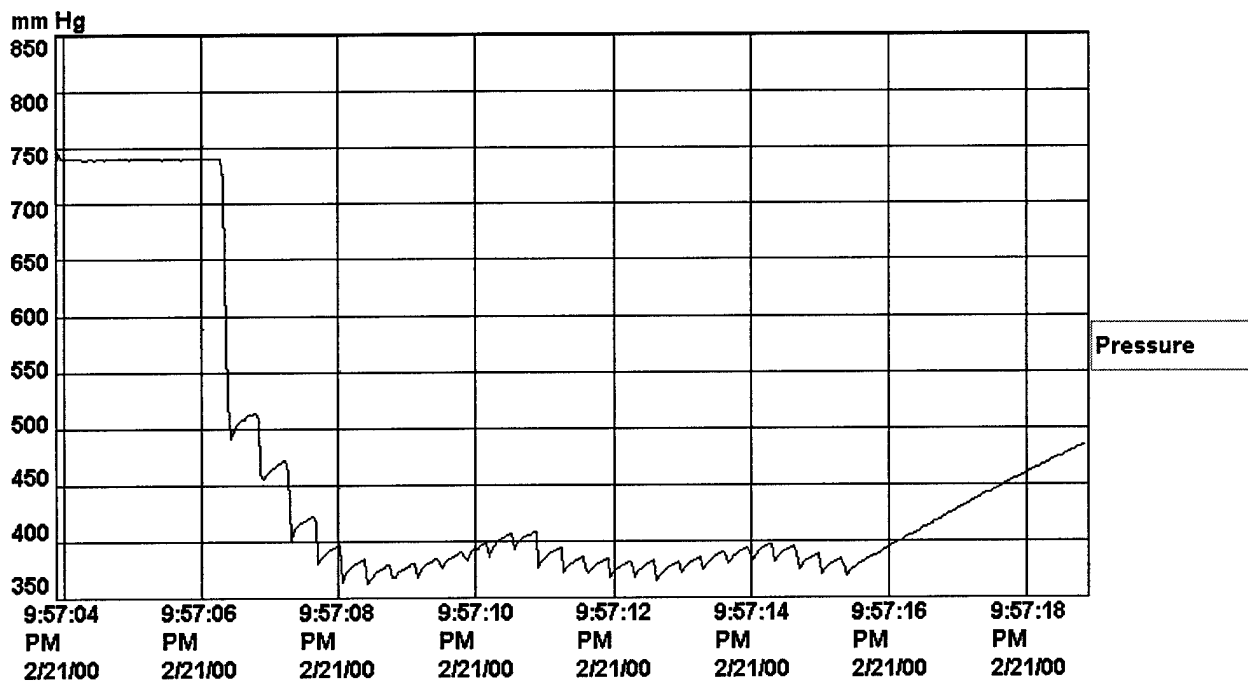

Figure 64: Reverse Bike Pump Pressure Test with Air

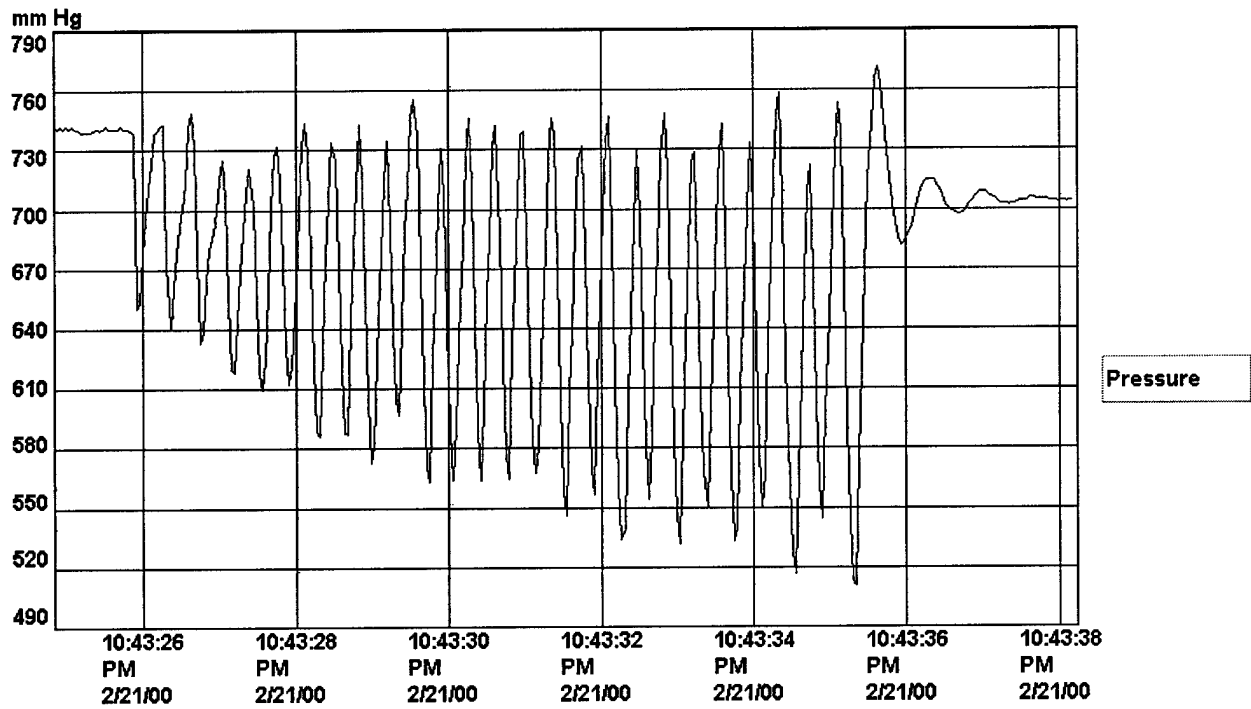

Figure 65: Reverse Bike Pump Pressure Test with Water

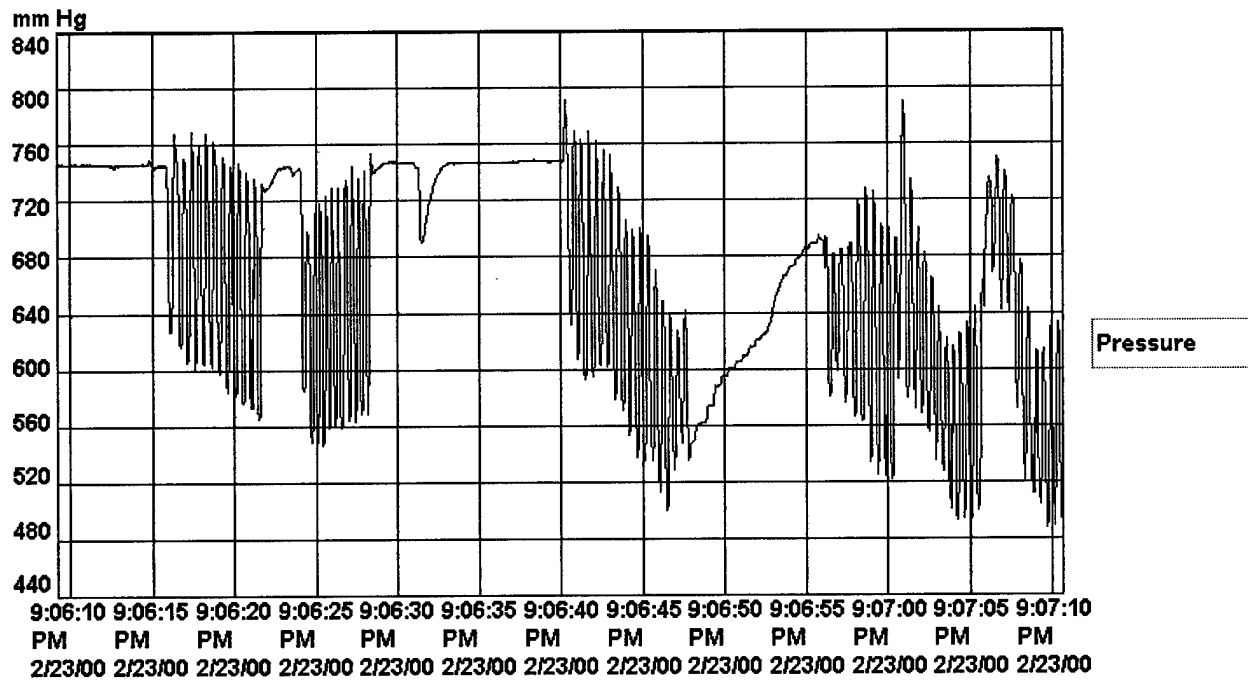

Figure 66: Reverse Bike Pump Pressure Test with Soup

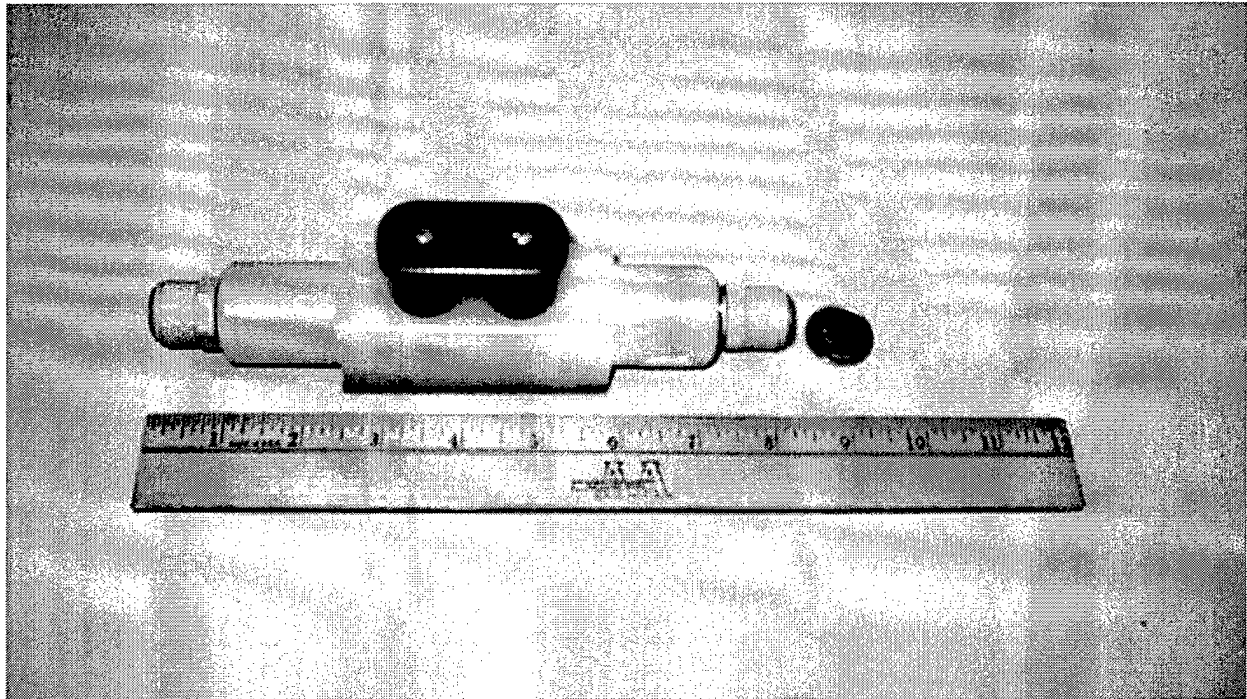

Figure 67: Photograph of the Double Piston Assembly

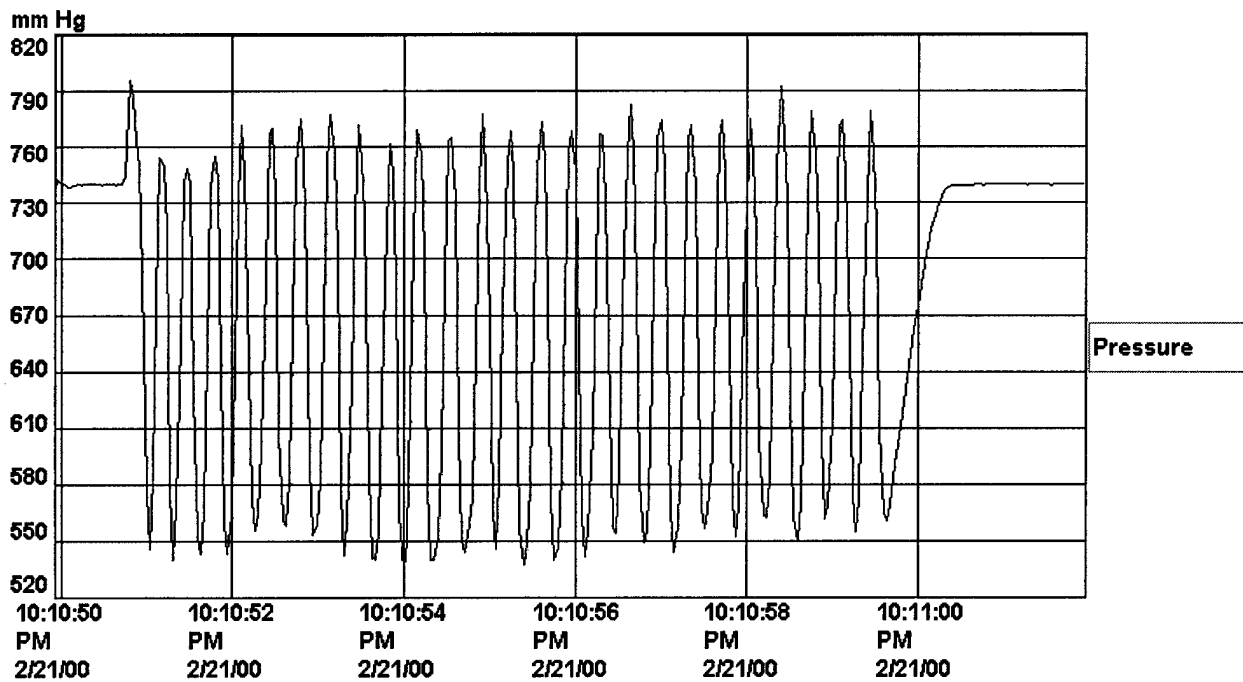

Figure 68: Double Piston Assembly Pressure Test with Air

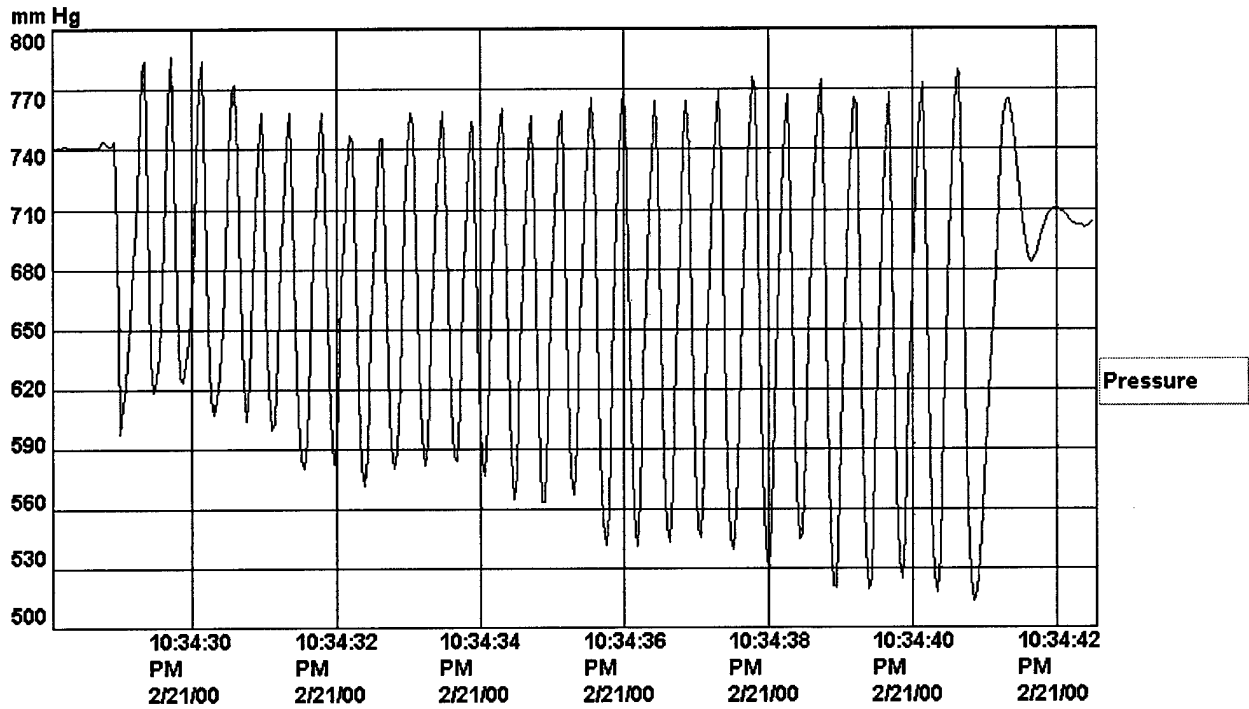

Figure 69: Double Piston Assembly Pressure Test with Water

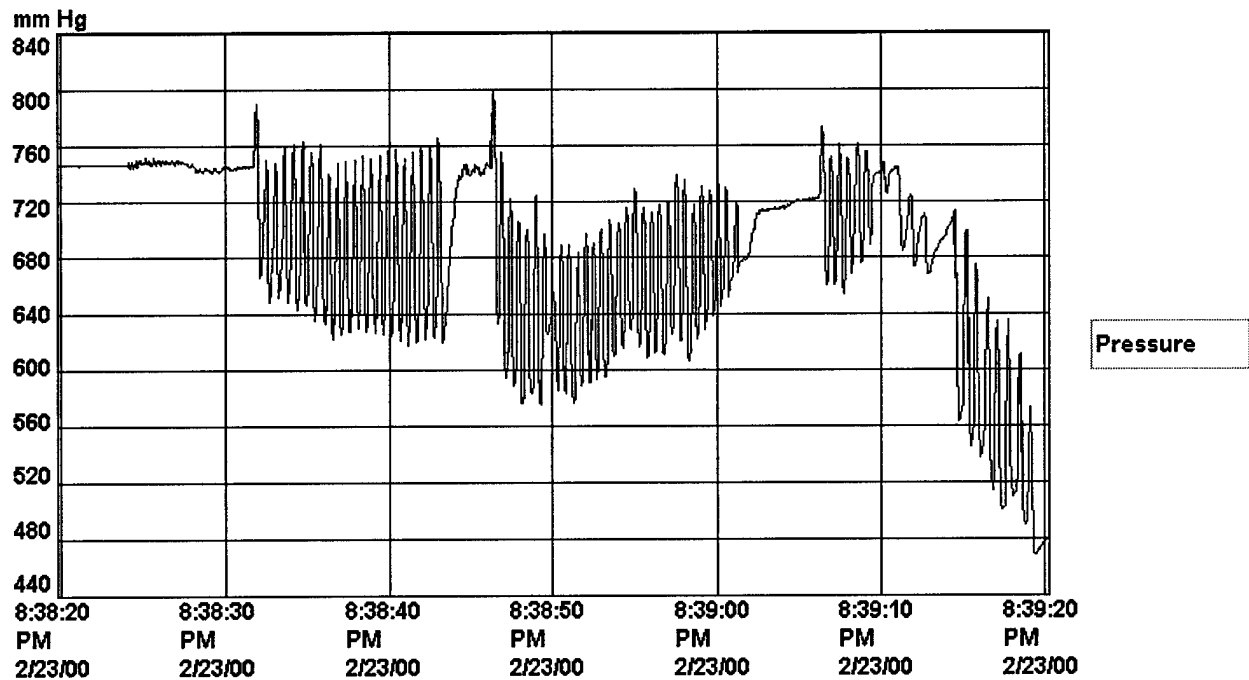

Figure 70: Double Piston Assembly Pressure Test with Soup

APPENDIX B - TABLES

Table 1: Concept Advantages and Disadvantages

Concept	Advantages	Disadvantages
Concept 1 Vitalograph	Good suction	Large
	Attachment capabilities	Too many mechanical parts
	One-handed	
Concept 2 Res-Q-Vac	Good suction	Large
	Attachment capabilities	Too many mechanical parts
	One-handed operation	
Concept 3 V-Vac	Attachment capabilities	Large
	Lightweight	
	One-handed operation	
Concept 4 Ambu-TwinSuction Pump	Good suction	Foot powered
		Mechanical parts
Concept 5 60-cc syringe	Simple	Two-handed operation
	Lightweight	
	Inexpensive	
Concept 6 Ambu-Power Pack Suction unit	Good peak suction	Battery powered
Concept 7 Impact Vac-Pak II	Lightweight	Battery powered
		Large
Concept 8 S-SCORT™9™	Good peak suction	Battery powered
		Heavy
Concept 9 S-SCORT™10™	Good peak suction	Battery powered
		Heavy
Concept 10 Laerdal Compact Suction Unit	Lightweight	Battery powered
	Disposable suction tube and canister	
	Small	
Concept 11 U.S. Patent 5,102,404	Small	Complexity
	Lightweight	
Concept 12 U.S. Patent 5,318,548	One handed operation	Limited suction capacity
	Small	
	Lightweight	
Concept 13 U.S. Patent 5,167,621	One handed operation	Bulky
	Protection for user	Limited suction capacity
Concept 14 U.S. Patent 4,979,944	Use of existing product	Limited suction capacity
	Small	Small intake opening
	Lightweight	

Table 1: Concept Advantages and Disadvantages (continued)

Concept	Advantages	Disadvantages
Concept 15 U.S. Patent 5,009,635	Lightweight	Limited suction force
	One handed operation	
	Small	
Concept 16 U.S. Patent 4,930,997	Unlimited suction capacity	Two handed operation
		Easily clogged
		Large
Concept 17 Mini V-Vac	Small	Limited suction force
	Lightweight	Difficult to operate repeatedly
	Durable	
Concept 18 The Bulb	Use of existing product	Limited suction force
	Ease of use	
	Lightweight	
Concept 19 The Syringe Thing	Lightweight	Two handed operation
	Unlimited suction capacity	
	Use of existing products	
Concept 20 Reverse Bike Pump	Use of existing product	Two handed operation
	Unlimited capacity	Moving Parts
	Lightweight	
Concept 21 Modified Syringe	Lightweight	Moving Parts
	One handed operation	
	Good suction	
Concept 22 Trigger-Activated Syringe	Lightweight	Moving parts
	One handed operation	
	Good suction	
Concept 23 Piston Assembly	Unlimited capacity	Moving parts
	One handed operation	
	Poor suction	
Concept 24 Hand-held Bellows	Durable	Moving parts
	One handed operation	Slow Mechanism
	Unlimited capacity	

Table 2: Reverse Bike Pump, Bill of Materials

Part #	Quantity	Material	Location	Nominal Dimensions
1	2	Acrylic	Milled-Tube.PRT	0.500 Dia. x 1.175 Long
2	1	Aluminum	Large-Tube.PRT	1.187 Dia. x 4.513 Long
3	1	Black Polycarbonate	Housing-A.PRT	1.000 Dia. x 0.600 Thick
4	1	Black Polycarbonate	Housing-B.PRT	1.000 Dia. x 0.600 Thick
5	1	Aluminum	End-Tube.PRT	1.188 Dia. x 2.088 Long
6	1	Aluminum	Inner-Tube.PRT	0.750 Dia. x 3.050 Long
7	1	Black Polycarbonate	End-Cap.PRT	1.000 Dia. x 0.300 Thick
8	2	Silicone Rubber	Washer.PRT	0.453 Dia. x 1/32 Thick
9	2	Stainless Steel	Valve Springs, Trakar P/N: 30-S-996	0.312 O.D. x 1.062 Long x 0.43 lbs/in. Rate
10	2	440-C Stainless Steel	Ball Bearings, McMaster P/N: 9529K19	3/8 Diameter
11	2	Gray Acetal	Instant Conn., McMaster P/N: 51055K17	3/8 O.D. x 1/4 NPTF Male
12	2	Buna-N Rubber	Hillman Fastner O-Ring	3/4 I.D. x 15/16 O.D. x 3/32 Thick

Table 3: Double Piston Assembly, Bill of Materials

Part #	Quantity	Material	Name or Ref. #	Nominal Dimensions
1	2	Black Polycarbonate	Piston.PRT	0.980 Dia. x 1.475 Long
2	1	White Nylon 6/6	Block.PRT	1.275 Thick x 1.375 Wide x 6.150 Long
3	1	Black Polycarbonate	Housing-A.PRT	1.000 Dia. x 0.600 Wide
4	1	Black Polycarbonate	Housing-C.PRT	1.000 Dia. x 0.350 Wide
5	1	Black Polycarbonate	Housing-D.PRT	1.000 Dia. x 0.250 Wide
6	1	Black Nylon 6/6	Back-Cover.PRT	0.250 Thick x 1.375 Wide x 3.325 Long
7	2	Acrylic	Milled-Tube.PRT	0.500 Dia. x 1.175 Long
8	1	Black Nylon 6/6	Palm-Grip.PRT	0.250 Thick x 1.125 Wide x 2.250 Long
9	2	Silicone Rubber	Washer.PRT	1/16 Thick x 0.453 Dia.
10	4	Buna-N Rubber	Hillman-Fastner O-Ring	Size #15, 3/4 I.D., 1 O.D., Width 1/8
11	2	440-C Stainless Steel	Ball Bearings, McMaster P/N: 9529K19	3/8 Dia.
12	2	Stainless Steel	Valve Spring, Trakar P/N: 30-S-996	0.312 O.D. x 1.062 Long x 0.43 lbs/in. Rate
13	2	302 Stainless Steel	Piston Spring, McMaster P/N: 9435K152	0.48 O.D. x 1.500 Long x 19.13 lbs/in. Rate
14	2	Brass	Fastener	6-32 Dia. X 1/4 Long
15	6	Brass	Fastener	6-32 Dia. X 1/2 Long
16	2	Gray Acetal	Instant Conn., McMaster P/N: 51055K17	3/8 O.D. x 1/4 NPTF Male

Table 4: Test Results

	Volumetric Size (in ³)	Weight (grams)	Dimensions (inches)	Vol. Of First Use (ml)	Vacuum Pressure, Wet gauge (mm Hg)	Vacuum Pressure, Dry gauge (mm Hg)
Requirements	< 75	< 300	< 3 x 4 x 5	200-400	90-200	90-200
Existing Designs						
Vitalograph	30	362	3.1 x 6.4 x 6.9	224	185	460
Res-Q-Vac	31	211	2.3 x 6.7 x 7.1	221	214	520
V-Vac	38	252	2.8 x 4.8 x 15.3	318	54	210
Prototypes						
Reverse Bike Pump	6	159	1.2 x 1.2 x 8.4	Unlimited	246	377
Double Piston Assembly	12	203	1.4 x 2.7 x 8.0	Unlimited	257	251