

JPRS 69368

6 July 1977

USSR AND EASTERN EUROPE SCIENTIFIC ABSTRACTS
PHYSICS AND MATHEMATICS
No. 36

USSR

EAST
EUROPE

DISTRIBUTION STATEMENT A
Approved for Public Release
Distribution Unlimited

20000324 194

U. S. JOINT PUBLICATIONS RESEARCH SERVICE

Reproduced From
Best Available Copy

REPRODUCED BY
NATIONAL TECHNICAL
INFORMATION SERVICE
U. S. DEPARTMENT OF COMMERCE
SPRINGFIELD, VA. 22161

NOTE

JPRS publications contain information primarily from foreign newspapers, periodicals and books, but also from news agency transmissions and broadcasts. Materials from foreign-language sources are translated; those from English-language sources are transcribed or reprinted, with the original phrasing and other characteristics retained.

Headlines, editorial reports, and material enclosed in brackets [] are supplied by JPRS. Processing indicators such as [Text] or [Excerpt] in the first line of each item, or following the last line of a brief, indicate how the original information was processed. Where no processing indicator is given, the information was summarized or extracted.

Unfamiliar names rendered phonetically or transliterated are enclosed in parentheses. Words or names preceded by a question mark and enclosed in parentheses were not clear in the original but have been supplied as appropriate in context. Other unattributed parenthetical notes within the body of an item originate with the source. Times within items are as given by source.

The contents of this publication in no way represent the policies, views or attitudes of the U.S. Government.

PROCUREMENT OF PUBLICATIONS

JPRS publications may be ordered from the National Technical Information Service, Springfield, Virginia 22151. In ordering, it is recommended that the JPRS number, title, date and author, if applicable, of publication be cited.

Current JPRS publications are announced in Government Reports Announcements issued semi-monthly by the National Technical Information Service, and are listed in the Monthly Catalog of U.S. Government Publications issued by the Superintendent of Documents, U.S. Government Printing Office, Washington, D.C. 20402.

Indexes to this report (by keyword, author, personal names, title and series) are available through Bell & Howell, Old Mansfield Road, Wooster, Ohio, 44691.

Correspondence pertaining to matters other than procurement may be addressed to Joint Publications Research Service, 1000 North Glebe Road, Arlington, Virginia 22201.

BIBLIOGRAPHIC DATA SHEET	1. Report No. JPRS 69368	2.	3. Recipient's Accession No.
	4. Title and Subtitle USSR AND EASTERN EUROPE SCIENTIFIC ABSTRACTS - PHYSICS AND MATHEMATICS, No. 36		5. Report Date 6 July 1977
7. Author(s)	8. Performing Organization Rept. No.		6.
9. Performing Organization Name and Address Joint Publications Research Service 1000 North Glebe Road Arlington, Virginia 22201		10. Project/Task/Work Unit No.	11. Contract/Grant No.
12. Sponsoring Organization Name and Address		13. Type of Report & Period Covered	14.
15. Supplementary Notes			
16. Abstracts The report contains abstracts and news items on aerohydrodynamics, magnetohydrodynamics, thermodynamics, physics of crystals and semiconductors, molecular, atomic and plasma physics, optics, spectroscopy, physical measurements, and on theoretical and applied mathematics.			
17. Key Words and Document Analysis. 17a. Descriptors USSR Lasers Eastern Europe Nuclear Physics Mathematics Structural Mechanics Acoustics Thermodynamics Optics Plasma Physics			
17b. Identifiers/Open-Ended Terms			
17c. COSATI Field/Group 12A, 20A, 20F, 20E, 20H, 20K, 20M, 20I			
18. Availability Statement Unlimited Availability Sold by NTIS Springfield, Virginia 22151		19. Security Class (This Report) UNCLASSIFIED	21. No. of Pages 73
		20. Security Class (This Page) UNCLASSIFIED	22. Price A04

USSR AND EASTERN EUROPE SCIENTIFIC ABSTRACTS
PHYSICS AND MATHEMATICS

No. 36

This serial publication contains abstracts of articles and news items from USSR and Eastern Europe scientific and technical journals on the specific subjects reflected in the table of contents.

Photoreproductions of foreign-language sources may be obtained from the Photoduplication Service, Library of Congress, Washington, D.C. 20540. Requests should provide adequate identification both as to the source and the individual article(s) desired.

CONTENTS	PAGE
Acoustics.....	1
Calorimetry.....	5
Classical Mechanics.....	8
Crystals and Semiconductors.....	9
Electricity and Magnetism.....	23
Fluid Dynamics.....	24
Lasers and Masers.....	35
Magnetohydrodynamics.....	51
Molecular Physics.....	56
Nuclear Physics.....	58
Optics and Spectroscopy.....	59
Statistical Mechanics.....	63
Stress, Strain and Deformation.....	64
Theoretical Physics.....	65
Thermodynamics.....	67

Acoustics

USSR

THE CHANGE IN SIGN OF THE ACOUSTIC CONDUCTION EFFECT IN n-In-Sb

Leningrad FIZIKA TVERDOGO TELA in Russian Vol 19 No 2, Feb 77 pp 508-512
manuscript received 20 Sep 76

BUGAYEV, A. S., GULYAYEV, YU. V., IVANOV, S. N., MANSFEL'D, G. D., and
KHAZANOV, YE. N., Institute of Radio Engineering and Electronics, Academy of
Sciences USSR, Moscow

[Abstract] This work is a continuation of earlier studies of the phenomenon of acoustic conduction in crystals of indium antimonide at liquid helium temperatures. The essence of the phenomenon consists in a change in conductivity of a semiconductor specimen under the influence of acoustic waves propagating through the crystal. Acoustic waves in the form of short pulses with rf space factor are excited by means of an electroacoustic transducer and perform repeated runs through the crystal. The change in conductivity of the specimen under the influence of the acoustic waves in the direction perpendicular to their propagation is measured. It is shown that the basic regularities of the effect can be explained by peculiarities of heating of the electron gas by the sonic wave, namely by the presence of a wave of electron temperature accompanying the sonic wave. Figures 3; references 6: 3 Russian, 3 Western.

USSR

UDC 621.315.592

STRICT CONDITIONS FOR AMPLIFICATION OF ULTRASOUND IN PIEZOELECTRIC SEMI-CONDUCTORS

Leningrad FIZIKA I TEKHNIKA POLUPROVODNIKOV in Russian No 3, 1977 pp 581-584
manuscript received 24 Aug 76

GULYAYEV, YU. V., ZIL'BERMAN, P. YE., and SHIBANOVA, N. N., Institute of Radio Engineering and Electronics of the USSR Academy of Sciences, Moscow

[Abstract] The subject of this paper is the feasibility of observing strict conditions for amplification of ultrasound with high supercritically in piezoelectric semiconductors, in light of the fact that acoustoelectronic phenomena with high supercriticality are rather singular in nature and that these phenomena have not yet been studied sufficiently. A theoretical discussion is presented for semiconductors without hot electrons and for ultrasound of low frequency, in the sense that the product of the sound's wave number and the mean free path of electrons is much less than unity. It is assumed that the concentration mechanism of nonlinearity which is ordinary for these conditions is dominant. An equation is given which expresses the conditions under which amplification of weak ultrasound is curtailed, in terms of field, although sufficiently intense sound will be amplified under these same conditions. These conditions correspond to a field which exceeds the strict amplification

threshold. A previous study showed the possibility of the existence of unstable stationary waves under these conditions, which can exist only when the field for these conditions exceeds in value the strict amplification threshold but is less than a certain cutoff field. An expression is derived for the threshold intensity of sound fed to the crystal's input with which strict amplification is possible. By the theoretical analysis carried out here a new role which a stationary wave can play was discovered. It was previously thought that this type of wave could be obtained as the result of amplifying a weak sound signal when the amplification is limited owing to nonlinear effects. It is apparently not possible to obtain an unstable stationary wave, but the stationary wave determines the strict amplification threshold. Theoretical estimates are made for transverse waves in CdS crystals whereby a characteristic curve is given showing that the threshold intensity of sound entering the crystal increases drastically with an increase in field in the crystal. It is shown further that an effect similar to strict amplification is possible when the field in the crystal is less in value than the strict amplification threshold, provided that the supercriticality remains sufficiently high, but in this case it is a question of integral amplification for the entire crystal, rather than local amplification, as above, and the effect is manifested in an entirely different way. In this case slight amplification is observed with slight intensity of sound entering the crystal, but after reaching a certain critical intensity the amplification increases in jumps. It is suggested that experimental observation of the effects described here would be very valuable for revealing the nature of nonlinear sound amplification with high supercriticality. Figures 2; references 8: 6 Russian, 2 Western.

USSR

UDC 541.124:532.5

LIMITING EXPRESSIONS FOR INTERMEDIATE SPEEDS OF SOUND IN NON-EQUILIBRIUM FLOWS WITH AN ARBITRARY NUMBER OF CHEMICAL REACTIONS

Moscow PRIKLADNAYA MATEMATIKA I MEKHANIKA in Russian Vol 41 No 1, Jan/Feb 77 pp 102-112 manuscript received 4 Jun 76

NI, A. L., and RYZHOV, O. S., Moscow

[Russian abstract provided by the source]

[Text] It is shown that the Gibbs relation remains invariant for linear transformations that are used to reduce the kinetic matrix of reactions to a unit matrix, and to reduce the matrix of chemical stability of the system to a diagonal matrix. This enables one to treat the new variables as thermodynamic parameters that give the state of the relaxing mixture. Expressions are derived for intermediate rates of propagation of small-amplitude waves in the limiting case where the eigenvalues of the relaxation matrix differ in order of magnitude. It is found that the limiting expressions can be represented by formulas for partially frozen and partially equilibrium speeds of sound in the new thermodynamic variables. References 7: 4 Russian, 1 Polish, 2 Western.

USSR

THERMODYNAMIC DESCRIPTION OF THE ELECTROACOUSTIC ECHO IN CRYSTALS

Leningrad FIZIKA TVERDOGO TELA in Russian Vol 19 No 4, Apr 77 pp 1156-1158
manuscript received 2 Oct 75, after final revision 12 Jul 76

BONDARENKO, V. S., BOCHKOV, B. G., and ZUYEV, V. YE.

[Abstract] The authors consider the mechanism of the two-pulse electroacoustic echo in crystals in the degenerate case, consisting in parametric interaction between the acoustic wave piezoelectrically induced by a first radio pulse with the electric field of a second pulse with different frequency and wave number. This interaction produces a burst of acoustic waves with opposite phase divergence. The maximum piezoelectric signal (echo) arises when the elastic waves are in phase, which occurs when the elapsed time after the first pulse is equal to twice the delay time between rf pulses. An expression is found for the components of the tensor of mechanical stresses in the reversed wave, the first term describing the interaction of the field of the second pulse with the electric field accompanying the initial acoustic wave, while the second term describes the interaction of mechanical deformation of the initial wave with the field of the second pulse. It is shown that crystal anisotropy limits phasing of reversed waves, leading to a reduction in the number of components of the tensors that describe the two-pulse electroacoustic echo when waves propagate along crystal axes. A table is given summarizing the reduction in tensor components for different symmetry groups. The authors thank G. A. Smolenskiy for interest in the work. Table 1; references 3: 2 Russian, 1 Western.

USSR

PLASMA ACOUSTIC WAVES IN A BOUNDED SEMIMETAL

Leningrad FIZIKA TVERDOGO TELA in Russian Vol 19 No 3, Mar 77 pp 756-760
manuscript received 10 Feb 76, after final revision 16 Sep 76

LEVIYEV, G. I., Institute of Solid State Physics, Academy of Sciences USSR, Chernogolovka

[Abstract] A theory of acoustic plasma waves in bismuth was outlined in an earlier paper by O. V. Konstantinov and V. I. Perel' [Fizika Tverdogo Tela, Vol 9, 1967 p 3051], where the authors used the actual model of the Fermi surface of bismuth and determined the velocity and attenuation of these waves in an unbounded semimetal. They also considered the excitation of acoustic waves in a plate located in a homogeneous electric field perpendicular to the surface of the plate, assuming that the electrons and holes are specularly reflected at the boundary. In this paper G. I. Leviev considers excitation of waves in a half-space by a perpendicular field, and analyzes cases of both

specular and diffuse reflection of electrons and holes from the boundary. It is assumed that the longitudinal field inside the metal depends considerably on the conditions of reflection at the boundary (the transverse field is almost independent of the conditions of reflection). The problem of penetration of the normal field into the half-space is solved, and the asymptotic form of the field is found at large distances from the boundary. The feasibility of experimental observation of plasma acoustic waves is discussed. The author thanks V. P. Gurariy for assistance with the work. Figure 1; references 8: 6 Russian, 2 Western.

Calorimetry

USSR

COMBUSTION OF EXPLOSIVE COMPOUNDS WITH NITROGEN-NITROGEN BONDS

Novosibirsk FIZIKA GORENIYA I VZRYVA in Russian Vol 12 No 6, Nov/Dec 76 pp 827-836 manuscript received 8 Sep 75

FOGEL'ZANG, A. YE., SVETLOV, B. S., ADZHEMYAN, V. YA., KOLYASOV, S. M., SERGIYENKO, O. I., and PETROV, S. M., Moscow Institute of Chemical Technology

[Abstract] Experiments were performed in a constant pressure chamber and in a vacuum chamber with a volume of 40 l. Charges were pressed into pipes of acrylic resin 4 or 7 mm i.d. at 2000-4000 kg/cm². The distribution of temperature in the combustion wave was measured by a tungsten-rhenium thermocouple 5 μm thick. The combustion of methylene dinitroamine, ethylene dinitroamine, tetramethylene dinitroamine, cyclotetramethylene tetranitroamine, nitrourea, nitroguanidine, azobis- and hydrazo-bis-nitroformamidine, N-nitroaniline, o-, m- and p-nitroaniline, 2,4-dinitroaniline, 2,3,4,6-tetranitroaniline, nitrosoguanidine and cyclotrimethylene trinitrosoamine was studied. The function $u(I_0)$ was determined for some of these compounds (-80 - + 150°C) and the thermocouples embedded in the compounds at high pressure were used to measure the distribution of temperatures across the combustion wave. Figures 9; tables 3; references 38: 20 Russian, 1 Czech, 17 Western.

USSR

UDC 536.46

ON THE RELATION BETWEEN FLAME TEMPERATURE AND THE COMPOSITION OF PRODUCTS OF COMBUSTION OF BALLISTIC POWDERS

Novosibirsk FIZIKA GORENIYA I VZRYVA in Russian Vol 13 No 1, Jan/Feb 77 pp 132-135 manuscript received 30 Oct 75

DAVIDCHUK, YE. L., MAL'TSEV, V. M., MARGOLIN, A. D., PETROV, YU. M., and RYABIKOV, O. B., Institute of Chemical Physics, Academy of Sciences USSR, Moscow

[Russian abstract provided by the source]

[Text] The authors calculate the composition of the products of combustion of powders based on nitrocellulose and nitroglycerin at pressures of 1-20 atmospheres in the case of kinetically incomplete combustion. The measured flame temperature was used based on the assumption that all combustion products except nitric oxide are in chemical equilibrium. The results of the calculation are compared with experiment. The method of calculation is apparently applicable to analysis of nitro esters and nitro compounds with the C-NO₂ bond in the region of kinetically incomplete combustion at temperatures above 1000-1500 K where nitrogen dioxide is already used up. Figure 1; tables 2; references 5 (Russian).

USSR

UDC 662.311.1

THREE CHARACTERISTIC MODES OF COMBUSTION OF BALLISTIC POWDERS IN THE PRESENCE OF A PRESSURE DROP

Novosibirsk FIZIKA GORENIYA I VZRYVA in Russian Vol 13 No 1, Jan/Feb 77 pp 14-19 manuscript received 17 Dec 75

ZEMSKIKH, V. I., ISTRATOV, A. G., LEYPUNSKIY, O. I., and MARSHAKOV, V. N.,
Institute of Chemical Physics, Academy of Sciences USSR, Moscow

[Russian abstract provided by the source]

[Text] A study is done in a "bomb-receiver" installation on combustion conditions in a charge of H powder in the presence of a pressure drop. Tungsten-rhenium thermocouples are used to study changes in temperature in the gas zone close (within 1 mm) to the hot surface of the channel as the pressure drops. Three modes of combustion are distinguished: quasi-stationary, with repeated ignition and with complete extinction of the powder. An investigation is made of the feasibility of separating the regions of existence of these modes in coordinates that characterize the depth and rate of the pressure drop. Figures 2; references 10: 6 Russian, 4 Western.

USSR

UDC 533.9:543.42

SPECTROSCOPIC MEASUREMENTS OF THE TEMPERATURE OF A NITROGEN PLASMA IN A GRAPHITE REACTOR

Minsk ZHURNAL PRIKLADNOY SPEKTROSKOPII in Russian Vol 26 No 2, Feb 77 pp 231-234 manuscript received 29 Sep 75

MEL'NIKOV, B. I., GOSTEMINSKAYA, T. V., LYUTYY, A. I., MOROZOV, V. P., and PARKHOMENKO, V. D.

[Abstract] The paper gives the results of spectroscopic measurements of the temperature of a nitrogen plasma in a graphite channel. The experimental setup is shown in the diagram.

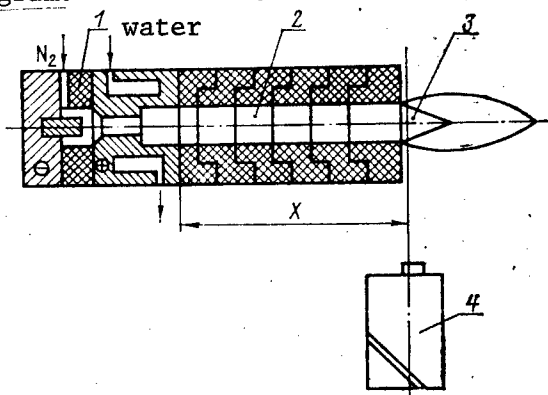

The nitrogen plasma was generated in an electric-arc plasmotron. Directly attached to the outlet aperture of the plasmotron is a cylindrical graphite reactor. The length X could be varied by changing the number of sections. Temperature measurements were made with the ISP-30 spectrograph. The measurements were based on the relative distribution of intensity of the rotational lines of the N₂ and CN bands. The radial and axial temperature distributions in the plasma show appreciable heat losses lengthwise of the graphite channel. Figures 4; references 12: 11 Russian, 1 Western.

USSR

UDC 536.46

STEADY-STATE COMBUSTION OF DECOMPOSABLE AND VAPORIZABLE CONDENSED SUBSTANCES

Novosibirsk FIZIKA GORENIYA I VZRYVA in Russian Vol 13 No 1, Jan/Feb 77 pp 3-9 manuscript received 9 Oct 75

STRUNIN, V. A., FIRSOV, A. N., SHKADINSKIY, K. G., and MANELIS, G. B., Division of the Institute of Chemical Physics, Academy of Sciences USSR, Chernogolovka

[Russian abstract provided by the source]

[Text] The authors formulate and solve the problem of steady-state combustion of a condensed substance, including reactions of decomposition in the condensed and gaseous phases and the process of vaporization. It is shown that single-zone and mixed two-zone combustion regimes exist, and an investigation is made of such modes of combustion. The mixed two-zone case conforms with a rule according to which the combustion rate is equal to the sum of the rates of single-zone combustion, while the pressure coefficient is equal to the half-sum of the corresponding pressure coefficients. Table 1; figures 5; references 12: 9 Russian, 3 Western.

USSR

UDC 531.383

INVESTIGATION OF PERTURBING MOMENTS OF FORCES OF VISCOUS FRICTION IN THE SUSPENSION OF A FLOATING GYROSCOPE

Moscow IZVESTIYA AKADEMII NAUK SSSR, MEKHANIKA TVERDOGO TELA in Russian No 1, Jan/Feb 77 pp 10-16 manuscript received 25 Dec 75

GORODETSKIY, O. M., Grodno

[Abstract] The author considers a floating gyroscope with cylindrical float. The device is shown in the diagram, where 1 is the base, 2 is the housing, 3 is the float and 4 is the rotor.

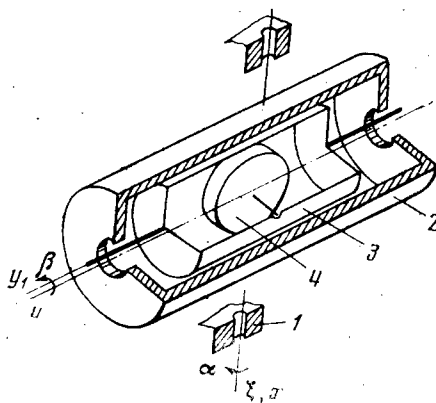

The space between the float and the housing is filled with a viscous incompressible fluid. Between the housing supports and the bearings fastened in the housing there is a certain clearance, and therefore within this gap the float may move translationally relative to the housing. The rotor exerts periodic forces on the float. The case where the resultant force is parallel to the base is considered. It is assumed that fluid flow is laminar and planar (the trajectories of all fluid particles are parallel to the base of the float), that the structure is absolutely rigid, that the intrinsic kinetic moment of the gyroscope is constant, that the resultants of the forces of gravity that are applied to the float with rotor and to the housing do not contain torques around the axes of rotation of the housing and float, and that there are no external disturbing torques. The rate of drift of the gyro is determined. The author thanks D. M. Klimov and V. F. Zhuravlev for formulating the problem and discussing the work. Figures 3; references 4 (Russian).

Crystals and Semiconductors

USSR

PECULIARITIES OF THE DISPERSION OF THE NONLINEAR INDEX OF REFRACTION OF GaAs AT HELIUM TEMPERATURES

Leningrad FIZIKA TVERDOGO TELA in Russian Vol 19 No 2, Feb 77 pp 602-603
manuscript received 20 Aug 76

BELOGUROV, D. A., and SHALDIN, YU. V., Institute of Crystallography, Academy of Sciences USSR, Moscow

[Abstract] An experimental study is presented on the temperature dependence of the nonlinear index of refraction $n^3 r_{321}$ (r_{321} is the coefficient of the linear electro-optical effect) of gallium arsenide in order to facilitate understanding of the nature of nonlinear polarization of crystalline media. Measurements of the dispersion of $n^3 r_{321}$ at helium temperatures were performed by the standard method in specimens of GaAs oriented relative to the crystallographic axes. The results of the study show that far from the band of absorption, the function $\epsilon n_{321}(h\nu)$ is described quite well by the function $(E_g - h\nu)^{-1/2}$, where E_g is the width of the forbidden band. Similar behavior is also observed at room temperature. As E_g is approached, a transition to $(E_g - h\nu)^{-3}$ is observed. This seems to be related to the increase in the contribution of exciton states. Figures 2; references 4: 3 Russian, 1 Western.

USSR

SCATTERING OF LIGHT BY BOUND PLASMON-PHONON OSCILLATIONS IN p-GaP AND THE LIFETIME OF OPTICAL PHONONS WITH $k=0$ IN INSULATING GaP

Leningrad FIZIKA TVERDOGO TELA in Russian Vol 19 No 2, Feb 77 pp 455-462
manuscript received 10 Aug 76

BAYRAMOV, B. KH., Institute of Engineering Physics imeni A. F. Ioffe, Leningrad

[Abstract] The scattering of light by plasma oscillations in p-GaP is studied in the concentration range 10^{16} - 10^{18} cm^{-3} . The line broadening and displacement observed with an increase in concentration of free carriers are explained by the existence of a bound state between LO phonons and plasma oscillations. Good agreement is achieved between calculated and experimental values of longitudinal frequencies of plasmon-phonon oscillations. The asymmetry of shape and anomalously broad line width of TO-phonons, which do not form a bound state with plasma oscillations, result from the existence of a bound TO-phonon state with TA (X, k) + LA(X) acoustic combination mode. In an insulating gallium phosphide crystal, the measured line width of LO-phonons is used to determine the mean lifetime of optical phonons. It is shown that in p-GaP crystals, the presence of free carriers of two types, both heavy and light holes formed by a two-component plasma, as a result of interaction of plasma oscillations with longitudinal optical oscillations of the lattice at $k=0$,

leads to expansion and displacement of the line observed in the light scattering spectrum. The author thanks Ye. L. Ivchenko, Z. M. Khashkhozhev and B. P. Zakharchene for discussing the results. Figures 2; tables 2; references 32: 5 Russian, 27 Western.

USSR

UDC 621.382.2

PHOTOSENSITIVITY OF SURFACE-BARRIER Au - n-Si DIODES IN THE 1 TO 6 eV RANGE OF THE SPECTRUM

Leningrad FIZIKA I TEKHNIKA POLUPROVODNIKOV in Russian No 3, 1977 pp 502-505 manuscript received 3 Jul 76

GUTKIN, A. A., DMITRIYEV, M. V., and KHAIT, V. M., Physics and Engineering Institute imeni A. F. Ioffe of the USSR Academy of Sciences, Leningrad

[Abstract] Surface-barrier structures based on a semitransparent film of gold and silicon have a number of advantages over diffusion-type junctions, one being high sensitivity to radiation in the visible and ultraviolet regions of the spectrum. This paper makes a study of the photosensitivity spectra of surface-barrier Au -n-Si photodiodes over a wide range of photon energy, 1 to 6 eV, i.e., up to coefficients of absorption of light in silicon higher than $2 \cdot 10^6 \text{ cm}^{-1}$, and also of the influence of the concentration of impurity centers in silicon, which determine the barrier capacitance and electric field in it, on the magnitude of photosensitivity. It is necessary to know the impurity-center concentration's influence on photosensitivity when creating photodetectors for the visible and ultraviolet regions. The diodes studied are illuminated on the side of the semitransparent gold electrode. Photosensitivity was studied at 300 and 80 K in the photon energy range of 0.9 to 6.2 eV. The concentration of shallow donor centers in the Si for different specimens was within the range of $2 \cdot 10^{13}$ to $2 \cdot 10^{17} \text{ cm}^{-3}$. It was demonstrated that within this concentration range the effective quantum yield of these diodes in the 1.6 to 6.2 eV photon energy range does not depend on the fine donor center concentration in the Si. It has been concluded that losses in photosensitivity owing to diffusion of photoelectrons toward the metal electrode with high absorption coefficients are practically absent. With a gold electrode 107 Å thick the effective quantum yield at maximum photosensitivity of 2 eV is 0.5 and is reduced less than fourfold in the UV region of the spectrum. It is concluded that surface-barrier diodes based on silicon with a shallow donor concentration of approximately 10^{13} cm^{-3} and having low barrier capacitance can be used to create quick-response photodetectors with high photosensitivity in the visible and ultraviolet regions of the spectrum. Figures 2; references 21: 1 Russian, 2 Polish, 13 Western.

USSR

UDC 621.315.592

SINGLE-PARTICLE MONTE CARLO METHOD FOR CALCULATING THE DISTRIBUTION FUNCTION OF ELECTRONS IN VARIABLE FIELDS

Leningrad FIZIKA I TEKHNIKA POLUPROVODNIKOV in Russian No 3, 1977 pp 461-466
manuscript received 25 May 76

VIDRO, V. L., and GORFINKEL', V. B.

[Abstract] The single-particle Monte Carlo method making it possible to calculate the stationary distribution function in a homogeneous semiconductor and the multi-particle Monte Carlo method making it possible to determine the nonstationary distribution function were developed in papers published earlier. The multi-particle Monte Carlo method is inconvenient when calculating distribution functions in variable periodic fields since additional time is required to trace each particle to do away with the influence of initial conditions on the steady-state distribution function. In this paper a modification of the single-particle Monte Carlo method is suggested which makes it possible to calculate the nonstationary distribution function. The advantage of this method over the multi-particle method for calculations with variable periodic fields in a considerable savings in machine time. A formula is derived for the distribution function of electrons in wave vector space and with respect to time when variable periodic fields influence a semiconductor. A proof is given that this function satisfies the non-stationary Boltzmann equation. Using the method suggested, calculations were made of the mean drift velocity and temperature of electrons, as well as of valley population when applying a steady and variable field in gallium arsenide. Variable field frequencies differed; curves were plotted for 30, 100, and 476 GHz. Curves obtained for 30 and 100 GHz are in good agreement with similar curves plotted by other methods. Curves expressing these relationships with a variable field frequency of 476 GHz were obtained here for the first time and may be of interest in developing instrumentation for the EHF (millimeter and submillimeter) range. Figures 5; references 7 (Western).

USSR

UDC 621.315.529

A SUBMILLIMETER WAVEBAND H^- -TYPE SEMICONDUCTOR PHOTORESISTOR

Leningrad FIZIKA I TEKHNIKA POLUPROVODNIKOV in Russian No 3, 1977 pp 532-540
manuscript received 23 Aug 76

ALEKSANDROV, V. N., GERSHENZON, YE. M., MEL'NIKOV, A. P., and SEREBRYAKOVA, N. A., Moscow State Pedagogical Institute imeni V. L. Lenin

[Abstract] This paper deals with the feasibility of creating semiconductor photoresistors based on photoseparation by induced emission of electrons or holes from H^- centers in semiconductors--donors with an electron which is

superfluous as far as the neutral center is concerned (D^- centers), or acceptors with a superfluous hole (A^+ centers). This paper, which represents a continuation of earlier studies published by the authors, devotes its major attention to studying H^- -type photoresistors based on Si:B with an acceptor concentration of less than 10^{15} cm^{-3} , i.e., under conditions when it is possible to disregard photowarmup of carriers and the interaction of impurities. A^+ and D^- centers are ordinarily observed at low temperatures under essentially non-equilibrium conditions, when population of H^- states is achieved by extra excitation of free carriers with extrinsic or intrinsic illumination. Extrinsic excitation is dealt with here to a greater extent since an H^- -type photoresistor has worse characteristics with intrinsic excitation of carriers. Existing photoresistors made of Ge and n-GaAs have waveband sensitivity limitations which restrict their application in making spectral studies of different types of substances, in astrophysics, and the like. The purpose of the technology outlined here is to circumvent these disadvantages. The mechanism of photoconductivity is analyzed for both types of excitation, extrinsic and intrinsic, and an analysis is made of the choice of optimum conditions for functioning of the photoresistor. An H^- -type photoresistor with extrinsic excitation of free carriers is shown to have superior characteristics. The results are given of an experimental study of the properties of a photoresistor based on Si:B, and a determination is made of its individual parameters. It is concluded that an A^+ photoresistor made of Si:B has sensitivity in the 100 to 500 micron waveband which is not inferior to that of extrinsic photoresistors ordinarily used and can be used to supplement the photosensitivity spectrum range of certain receivers. Si:B is not the only material suitable for creating photoresistors according to the principle dealt with here. The use of Germanium with shallow impurities makes it possible to shift the photosensitivity region of H^- -type photoresistors into the longwave section of the submillimeter waveband. It is concluded that further studies of H^- -type photoresistors will show the feasibility of using them for the submillimeter waveband. Figures 8; references 23: 12 Russian, 11 Western.

USSR

UDC 621.315.592

IMPURITY DIFFUSION WHEN LASER ANNEALING IMPLANTED LAYERS

Leningrad FIZIKA I TEKHNIKA POLUPROVODNIKOV in Russian No 3, 1977 pp 603-606
manuscript received 11 Oct 76

KACHURIN, G. A., and NIDAYEV, YE. V., Institute of Semiconductor Physics of the Siberian Division of the USSR Academy of Sciences, Novosibirsk

[Abstract] This paper is devoted to the highly interesting question of impurity diffusion during pulsed laser annealing of implanted layers. Estimates have shown that for typical laser pulse durations of 10^{-3} and 10^{-8} s diffusive displacement of basic impurities in silicon is on the order of 10^{-7} and 10^{-9} cm even if the temperature of the layer exceeds 1000°C . A

number of experimental studies have shown a lack of any sort of widening of impurity distribution profiles after laser annealing which could be associated with the specific features of the laser effect. On the other hand there is data to the effect of considerable displacement of impurities under the effect of both millisecond and nanosecond laser pulses. Various reasons which could explain the accelerated migration of impurity atoms have been suggested, such as pushing aside of the impurity during solidification of the molten layer near the surface, acceleration of diffusion owing to the presence of an excessive concentration of defects, and the influence of an intensely excited electron gas. This paper gives the results of an experimental study of the impurity diffusion mechanism. Annealing of implanted layers was performed with single laser pulses of specific energy and duration, and the maximum temperature developed in the layer was controlled by extra heating. Studies were performed on KDB-10 silicon implanted with arsenic ions at 100 keV and $5 \cdot 10^{15}$ cm⁻² along line $\langle 111 \rangle$ at 20°C. Annealing was performed by exposure to single 6-ms pulses from a ruby laser. The power density of the incident radiation was 90 ± 10 J/cm². The irradiated specimen was placed in a massive aluminum unit whose temperature could be set within the range of 20 to 400°C. Donor distribution was monitored by Hall measurements in conjunction with successive removal of layers by means of anodic oxidation. It was found that increasing the temperature of the specimen during laser annealing by means of additional heating causes an increase in carrier mobility and the impurity utilization factor. Curves are given showing the change in layer conduction during successive removal of thin layers. These curves were used to calculate profiles of total free carrier concentration in annealed layers. Curves showing these results are given. It is shown that the results obtained cannot be explained by ordinary diffusion. It is concluded that the most probable reason for migration of impurities is acceleration of diffusion, which can be due either to an excessive concentration of vacancies or to displacement at interstices. Curves consistent with this theory were plotted experimentally. Interstitial diffusion has been shown to have an important role in thermal annealing of implanted layers. Rapid displacement of the impurity is made possible by the fact that a considerable portion of the impurity is found at interstices during annealing of the disordered layer. Thus accelerated diffusion is not typical of the laser effect alone. The effects observed here relate to the case when the implanted layer was amorphized, and it is not clear whether this condition is necessary for any combination of impurity and substrate. Figures 3; references 9: 7 Russian, 2 Western.

A SEMICONDUCTOR - EMULSION PHOTOGRAPHIC SYSTEM

Leningrad FIZIKA I TEKHNIKA POLUPROVODNIKOV in Russian No 3, 1977 pp 575-576
manuscript received 30 Jul 76

GORLIN, G. B., PARITSKIY, L. G., RYVKIN, S. M., TISNEK, T. V., and TULANOV, V. T., Physics and Engineering Institute imeni A. F. Ioffe of the USSR Academy of Sciences, Leningrad

[Abstract] This paper gives the characteristics of experimental semiconductor-emulsion photographic systems based on high-ohmic gallium arsenide doped with chromium and on silicon compensated with gold. The development of semiconductor photography is associated first and foremost with gaining control over the infrared region of the spectrum from the viewpoint of photographic sensitivity. It has been shown that good results can be obtained in working with systems whose operation is based on photoelectric interaction between semiconductors and radiation when working under low temperature conditions. Experiments studying the influence of an electric field on the sensitivity of a photographic emulsion have demonstrated that an emulsion can act as a potential-recording agent both at room temperature and at low temperatures. These findings have been used to construct semiconductor - emulsion photographic systems. The basic system described here consists of a photosensitive semiconductor, an opaque non-conductive shield, and a photographic emulsion whose sensitivity depends on the magnitude of the electric field found between two transparent electrodes which sandwich in the first three components. An image is projected onto the semiconductor and voltage is applied, whereby at the starting moment the voltage in each layer is inversely proportional to its capacitance. The voltage from the semiconductor will then pass over to the film and shield with a time constant determined by the conductance of the semiconductor, which is determined in turn by the exposure. Thus, over a specific period of time a charge image will appear on the film, corresponding to the distribution of light intensity in the image, which can be visualized by illuminating the film with a flash of actinic light. The two systems whose characteristics are determined here are based on using high-ohmic GaAs doped with chromium, with a spectrum sensitivity range not exceeding 1.4 microns and operating at room temperature, and on silicon compensated with gold, with sensitivity in the 1.1 micron region, operating at low temperature in liquid nitrogen. FT-SK film was used, its sensitivity depending substantially on the voltage applied. The shield was in the form of a thin carbon-black and lacquer coating applied to the surface of the semiconductor. An experimental study was made of the relationship between the optical density of the emulsion and the exposure time with steady illumination of the semiconductor, and of the relationship between optical density and the intensity of the light striking the semiconductor with a steady exposure time, and characteristic curves typifying the photographic process were plotted from these relationships. A determination was made of sensitometric characteristics. It is concluded that using as photo-detection layers semiconductors with a narrower forbidden band or impurity-type semiconductors with a corresponding set of levels will make it possible to shift the system's sensitivity further into the IR region of the spectrum. Figures 3; references 5 (Russian).

INFLUENCE OF WARMING UP ELECTRON GAS ON THE NEGATIVE MAGNETORESISTANCE EFFECT IN COMPENSATED GALLIUM ARSENIDE

Leningrad FIZIKA I TEKHNIKA POLUPROVODNIKOV in Russian No 3, 1977 pp 573-574
manuscript received 27 Jul 76

VUL, B. M., KOTEL'NIKOVA, N. V., ZAVARITSKAYA, E. I., and VORONOVA, I. D.,
Physics Institute imeni P. N. Lebedev of the USSR Academy of Sciences, Moscow

[Abstract] Earlier papers published by the authors made a study of the negative magnetoresistance of compensated gallium arsenide in a weak electric field of equal to or less than 10^{-1} W/cm, when the temperature of the electrons was practically the same as that of the crystal lattice. Heating of the electron gas begins in electric fields equal to or greater than 2 W/cm. This paper is devoted to determining the influence of heating the electrons on the negative magnetoresistance effect. Measurements were made in pulsed electric fields not exceeding 100 W/cm at approximately 1.8 K and with magnetic field strength of $5.6 \cdot 10^5$ A/m, thus making it possible to disregard the positive component of magnetoresistance. Results are given in graphic form for specimens of different initial electron mobility. In the specimens studied the negative magnetoresistance is reduced with an increase in electric field strength beginning with a field approximately equal to 5 W/cm and then becomes vanishingly small in fields of 20 to 50 W/cm, and the lowest fields are observed with samples with the greatest electron mobility. It was proven previously that negative magnetoresistance is reduced with an increase in the temperature of the crystal lattice, and it is therefore concluded here that the reduction in negative magnetoresistance observed in heating electric fields can be associated with an increase in the effective temperature of the electron gas. A formula is given for calculating this effective temperature. Calculations are made using the assumption that pulse-related scattering of electrons takes place in dipoles, which holds true for the temperature range of the study. Results of direct measurements of magnetoresistance as a function of the temperature of the crystal lattice and in a heating electric field as a function of the calculated effective electron temperature show good agreement. It is concluded that negative magnetoresistance is determined only by the temperature of the electron gas, and not by that of the crystal lattice. Figures 2; table 1; references 4: 3 Russian, 1 Western.

USSR

UDC 621.315.592

AMPLIFICATION OF OPTICAL LATTICE VIBRATIONS IN SEMICONDUCTORS BY THE FIELD OF AN ELECTROMAGNETIC WAVE

Leningrad FIZIKA I TEKHNIKA POLUPROVODNIKOV in Russian Vol 11 No 2, Feb 77 pp 421-422 manuscript received 19 Jul 76

EPSHTEYN, E. M.

[Abstract] Amplification of optical phonons in semiconductors by carrier drift requires a drift velocity of the order of 10^7 cm/s or higher. Therefore the author considers the feasibility of optical phonon amplification by interaction with electrons in the field of an electromagnetic wave. Longitudinal phonons of frequency ω_0 are assumed to interact with conduction electrons in the presence of the field of an electromagnetic wave $E_0 \sin \Omega t$. The electromagnetic wavelength is taken as large compared with the phonon wavelength and mean free path of the electron, so that the dipole approximation can be used. It is shown that photostimulated electron damping of optical phonons may become negative in a certain range of wave numbers in the presence of an electromagnetic wave because the absorption of this wave by conduction electrons is accompanied by the absorption and emission of an optical phonon; the absorption and emission correspond to different ranges of wave numbers. It is concluded that the amplification of optical phonons should be detectable from an increase in electromagnetic wave absorption or Raman scattering of light. References 6: 4 Russian, 2 Western.

USSR

UDC 621.315.592

X-RAY SPECTRAL STUDY OF THE ELECTRONIC STRUCTURE OF SEMICONDUCTOR PHOSPHIDES TYPE $A^{II}B^{IV}C_2^V$ AND $A^{III}B^V$

Leningrad FIZIKA I TEKHNIKA POLUPROVODNIKOV in Russian Vol 11 No 2, Feb 77 pp 379-387 manuscript received 15 Sep 76

GUSATINSKIY, A. N., BUNIN, M. A., BLOKHIN, M. A., BORSHCHEVSKIY, A. S., and PROCHUKHAN, V. D., Scientific Research Institute of Physics at Rostov State University, Rostov-na-Donu, Physico-Technical Institute imeni A. F. Ioffe, Academy of Sciences USSR, Leningrad

[Russian abstract provided by the source]

[Text] The authors examine the relation between the shape of x-ray spectra and the energy distribution of localized partial densities of states. An x-ray spectral study is done on the compounds GaP, BP, ZnSiP₂, ZnGeP₂, ZnSnP₂ (chalcopyrite and sphalerite), CdSiP₂, CdGeP₂ and CdSnP₂. For compounds $A^{III}B^V$ the authors find the fluorescent K-bands and emission $L_{II,III}$ -bands of phosphorus,

and for the ternary compounds--the fluorescent K-bands and K-absorption spectra. The K-spectra were corrected for the width of the inner level of an atom by a method that minimizes edge distortions.

For the $A^{III}B^V$ compounds the experimental data are used to plot curves of the local density of states that agree well with the calculated density of states for the entire crystal. A comparison of the emission bands of phosphorus for compounds $A^{II}B^{IV}C_2^V$ with calculations of the density of states and the charge density gave information on symmetry and localization of electron states. A small admixture of p-states is observed in the d-like states of the A^{II} atom; It is suggested that the latter participate weakly in the chemical bond. The observed differences in the shape of the spectra of the chalcopyrite and sphalerite modifications of $ZnSnP_2$ can be used for semiquantitative evaluation of the degree of ordering of cations in the lattice.

Most $A^{II}B^{IV}C_2^V$ compounds show good agreement between ΔE and E_g (ΔE is the energy gap between the end of emission and beginning of absorption of the corrected x-ray spectra, E_g is the width of the forbidden band determined by other physical methods). Possible causes of the discrepancy between these values for $ZnGeP_2$ and $CdSiP_2$ are examined. Figures 5; table 1; references 16: 11 Russian, 5 Western.

USSR

UDC 621.315.592

BORON-DOPED SILICON CARBIDE

Leningrad FIZIKA I TEKHNIKA POLUPROVODNIKOV in Russian Vol 11 No 2, Feb 77
pp 373-378 manuscript received 8 Sep 76

VODAKOV, YU. A., ZHUMAYEV, M., ZVEREV, B. P., LOMAKINA, G. A., MOKHOV, YE. N., ODING, V. G., SEMENOV, V. V., and SIMAKHIN, YU. F., Physico-Technical Institute imeni A. F. Ioffe, Academy of Sciences, Leningrad

[Russian abstract provided by the source]

[Text] The authors investigate SiC (6H) doped with boron during diffusion or epitaxial growth under considerably different conditions of dopant addition. The boron concentration was determined by neutron-activation analysis based on the reaction $^{10}B(n,\alpha)^7Li$. It is shown that at high concentrations above 10^{19} cm^{-3} and especially in surface layers of diffusion structures some of the boron is not in the electrically active state. At the same time the diffusion profile of boron in SiC shows a complicated shape.

Investigation of the electrically active component of boron in epitaxial and diffusion specimens showed two different acceptor energy levels associated with the presence of boron in the SiC lattice. The usual boron level with energy of 0.3-0.4 eV predominates in epitaxial specimens, while a deeper acceptor level with activation energy of 0.6 eV shows up in diffusion specimens close to the pn junction at concentrations of the order of 10^{18} cm^{-3} . It is

suggested that the deep acceptor center is identical to that responsible for effective high-temperature "boron" luminescence. It is most probable that the arisal of the deep acceptor level in boron-doped crystals is due to the additional introduction of intrinsic defects. Figures 5; references 14: 7 Russian, 7 Western.

USSR

UDC 621.315.592

ANISTROPY OF ELECTRIC PROPERTIES OF α -GeTe

Leningrad FIZIKA I TEKHNIKA POLUPROVODNIKOV in Russian Vol 11 No 2, Feb 77
pp 296-300 manuscript received 12 Jul 76

KORZHUYEV, M. A., SHELIMOVA, L. Y., and ABRIKOSOV, N. KH., Institute of Metallurgy imeni A. A. Baykov, Academy of Sciences USSR, Moscow

[Russian abstract provided by the source]

[Text] The authors measure the temperature dependences of the components of the tensors of electrical resistance ρ , Hall constant R and thermoelectromotive force α of a single crystal of germanium telluride $Ge_{1-x}Te_x$ containing $x = 50.36$ at. % Te.

The ρ , R and α showed anisotropy that vanished above $T_c = 668$ K. The anisotropy that shows up in the properties below T_c is attributed to splitting of aspherical L-extrema of the valence band of GeTe due to rhombohedral lattice deformation accompanying a phase transition. Figures 2; references 15: 10 Russian, 5 Western.

USSR

UDC 621.315.592

LUMINESCENCE OF SILICON-DOPED EPITAXIAL GALLIUM ARSENIDE

Leningrad FIZIKA I TEKHNIKA POLUPROVODNIKOV in Russian Vol 11 No 2, Feb 77
pp 230-232 manuscript received 21 Apr 76

ARNAUDOV, B. G., BYKOVSKIY, V. A., and DOMANEVSKIY, D. S., Belorussian State University imeni V. I. Lenin, Minsk, Sofia University imeni K. Okhridskiy, Bulgaria

[Russian abstract provided by the source]

[Text] A quantitative study was done on the influence that fluctuations in the potential of nonhomogeneously distributed impurities have on some parameters of luminescence of silicon-compensated ($N_{Si} = 5 \cdot 10^{18} - 5 \cdot 10^{19} \text{ cm}^{-3}$) gallium arsenide made by a liquid epitaxy method.

The cathodoluminescence and photoluminescence spectra at 80 K show a band B with a maximum that shifts toward higher frequencies with increasing rate of generation, lying in the 1.37-1.47 eV region. The nature and limits of displacement of band B agree satisfactorily with the calculated values of the potential fluctuations. The spectra of the most heavily doped specimens also showed a band A with maximum independent of the rate of generation lying at 1.49 eV. Band A may be due to recombination of free electrons and holes, which corresponds well with the calculated position of the energy levels in the experimental specimens. The authors thank M. A. Moldovanova and V. D. Tkachev for continued interest in the work and constructive criticism. Figures 2; table 1; references 10: 6 Russian, 4 Western.

USSR

UDC 621.315.592

INFLUENCE OF PRESSURE ON INTERBAND TUNNEL CURRENT IN GALLIUM ARSENIDE

Leningrad FIZIKA I TEKHNIKA POLUPROVODNIKOV in Russian Vol 11 No 2, Feb 77
pp 222-225 manuscript received 24 Mar 76

ALEKSEYEVA, Z. M., VYATKIN, A. P., and KRIVOROTOV, N. P., Siberian Physico-Technical Institute imeni V. D. Kuznetsov, Tomsk

[Russian abstract provided by the source]

[Text] The authors study the influence of hydrostatic pressure on the interband tunnel current of GaAs tunnel diodes. A comparison is made between experimental and theoretical relations $\frac{d \ln I}{dP} = f(V)$ for bias voltages $0 \leq V \leq V_p$

[where V_p is the voltage corresponding to the maximum tunnel current]. The authors establish the pressure dependence of the reduced effective mass of an electron and a light hole $\frac{d \ln m_r}{dP} = (6.7 \pm 0.8) \cdot 10^{-6} \text{ bar}^{-1}$, and also of the

effective mass of a heavy hole $\frac{d \ln m_{ph}^*}{dP} = (10 \pm 1) \cdot 10^{-6} \text{ bar}^{-1}$. Figures 2;

references 13: 6 Russian, 7 Western.

PHOTOCONDUCTIVITY OF ZINC SULFIDE CRYSTALS WITH LASER STIMULATION IN THE VICINITY OF THE ABSORPTION EDGE

Leningrad FIZIKA I TEKHNIKA POLUPROVODNIKOV in Russian Vol 11 No 2, Feb 77
pp 217-221 manuscript received 25 Feb 76

MYL'NIKOV, V. S., and KOZYREV, V. K.

[Russian abstract provided by the source]

[Text] For high-resistance zinc sulfide crystals in a longitudinal cell the authors study the way that photoconductivity (i_{ϕ}) depends on the intensity (L) of nitrogen laser emission, and also investigate the photocurrent-voltage characteristics of the crystals. It is shown that $i_{\phi} \propto L^k$, where k varies from 2 to 1 with an increase in voltage across the electrodes from 300 to 1400 V. The photocurrent-voltage characteristics are sharply nonlinear with an exponent varying from 3 to 8 as L is reduced by 1.5 orders of magnitude from the maximum intensity of $5 \cdot 10^{22}$ kV/cm².s. The characteristics depend on the polarity of the electrodes. The nonlinearity of current-illumination relations suggests that carriers are generated by two-photon absorption. The strong dependence of i_{ϕ} on voltage is apparently due to the appreciable contribution of recombination processes, and possibly to the behavior of drift processes in the mechanism of photoconductivity. This latter behavior is confirmed by the way that the carrier drift time depends on the intensity of laser stimulation. The authors thank A. M. Bonch-Bruyevich for interest in the work. Figures 3; references 12: 3 Russian, 9 Western.

USSR

K₂CrO₄, Rb₂CrO₄ AND Cs₂CrO₄ -- NEW FERROELASTIC MATERIALS

Leningrad FIZIKA TVERDOGO TELA in Russian Vol 19 No 3, Mar 77 pp 865-867
manuscript received 18 Sep 76

DUDNIK, YE. F., Dnepropetrovsk State University

[Abstract] A report on detection of domain structure and phase transitions in single crystals of K₂CrO₄, Rb₂CrO₄ and Cs₂CrO₄. Transparent yellow crystals were grown by spontaneous crystallization from equimolar suspensions of K₂CO₃, Cs₂CO₃, Rb₂CO₃ and CrO₃. Observations in polarized light at room temperature showed a complex domain pattern. Analysis showed that a sixth order axis is lost during phase transition. Application of uniaxial mechanical stress changes the domain structure. As the temperature increases in the range of 200-300°C, rearrangement of the domain structure of the crystal is observed: the fine domain network disappears and the domains become larger. A pronounced change in domain structure is observed at about 240°C

in Rb_2CrO_4 single crystals. With a further increase in temperature, the color of the crystal changes, after which a phase transition is observed that is accompanied by disappearance of the domain structure. Above the phase transition point the crystals become uniaxial, but when cooled below the Curie point they are once more broken up into domains. The observed behavior of these crystals indicates that they have ferroelastic properties. The author thanks Ye. V. Sinyakov for continued interest in the work. Figure 1; table 1; references 3: 2 Russian, 1 Western.

USSR

ON THE THEORY OF DYNAMIC POLARIZATION OF NUCLEI WITH OPTICAL ORIENTATION OF CONDUCTION ELECTRONS IN SEMICONDUCTORS IN ARBITRARY MAGNETIC FIELDS

Leningrad FIZIKA TVERDOGO TELA in Russian Vol 19 No 4, Apr 77 pp 986-990
manuscript received 20 Jul 76

BUIHVILI, L. L., VARDOSANIDZE, T. G., and UGULOVA, A. I., Institute of Physics, Academy of Sciences Georgian SSR, Tbilisi

[Russian abstract provided by the source]

[Text] The nonequilibrium statistical operator method is used to study the problem of dynamic polarization of nuclei in semiconductors in arbitrary magnetic fields (as well as in the absence of an external field) under conditions of optical orientation of conduction electrons. Equations are derived for the populations of energy levels of donor electrons and nuclei, and these equations are solved for the steady-state case. Expressions are derived for the mean values of polarization of donor electrons and nuclei. The authors investigate the influence that spin-lattice relaxation of donor electrons has on the magnitudes of polarization. References 9: 8 Russian, 1 Western.

ON THE THERMODYNAMICS OF MAGNETIC QUASI-MOLECULES IN A MAGNETIC SEMICONDUCTOR

Moscow DOKLADY AKADEMII NAUK SSSR in Russian Vol 233 No 3, 21 Mar 77 pp 335-337 manuscript received 2 Aug 76

BORUKHOVICH, A. S., and BAMBUROV, V. G., Institute of Chemistry, Ural Science Center, Academy of Sciences USSR, Sverdlovsk

[Abstract] A ferromagnetic semiconductor -- europium monoxide EuO -- is doped with bivalent samarium, and an investigation is made of the change in thermodynamic characteristics of the resultant $\text{Eu}_{1-x}\text{Sm}_x\text{O}$ solid solutions. It was found that the polycrystal specimens consist of a single phase from $x = 0$ to $x = 0.12$. The lattice parameter (type NaCl crystal) changed from 5.143 \AA for EuO to 5.128 \AA for $\text{Eu}_{0.89}\text{Sm}_{0.11}\text{O}$. The Curie point increases from 69 K at $x = 0$ to 124 K at $x = 0.12$. The polytherms of heat capacity show two magnetic disordering temperatures, the relative difference between them being determined by the samarium content in the solid solution. The low-temperature λ -transformation is weakly dependent on x , and is apparently the result of dissociation of "direct" ferromagnetic exchange $\text{Eu}^{2+}\text{-Eu}^{2+}$ characteristic of the pure monoxide, while the second Curie point rises sharply, reaching a maximum at $x = 0.084$. High-temperature disordering can be attributed to exchange between magnetic quasi-molecules formed on the basis of a central samarium impurity ion and the nearest twelve magnetic Eu^{2+} ions. Assuming uniform distribution of such quasi-molecules through the crystal, they should correspond in number to about 8 mol.% samarium ions in the solid solution. These quasi-molecules are thermodynamically stable and make a positive contribution to the heat capacity at temperatures exceeding the Curie point of EuO . Estimates of this contribution give a magnetic energy of about 252 J/mole and magnetic entropy of about $2 \text{ J/(mole}\cdot\text{deg)}$. The authors thank A. A. Samokhvalov for reading the manuscript and making comments, and also M. S. Marune for assistance with the experiment. Figures 2; references 8: 4 Russian, 4 Western.

Electricity and Magnetism

USSR

UDC 537.565:546.34

CHARGE MOBILITY IN LIQUID, SOLID AND DENSE GASEOUS HELIUM

Moscow USPEKHI FIZICHESKIKH NAUK in Russian Vol 121 No 3, Mar 77 pp 457-497

SHIKIN, V. B., Institute of Solid State Physics, Academy of Sciences USSR, Chernogolovka, Moskovskaya Oblast

[Russian abstract provided by the source]

[Text] The purpose of this survey is a systematic exposition of a large number of experimental and theoretical results recently obtained in studying the motion of charged particles in liquid, solid and gaseous helium. The diversity of possibilities leads to the necessity of dividing up the general problem of motion of charged particles in helium into a number of "autonomous" regions. The survey deals with motion of charges in a homogeneous medium at fairly low velocities. Chapter 1 describes the structure of helium ions -- positive (cations) and negative (anions) -- in liquid helium. It is noted that there is good agreement between theoretical concepts and the observed characteristics of ions in helium. An investigation is made of the question of nucleation of electron bubbles in dense gaseous helium. Chapter 2 contains the sum total of theoretical and experimental results on the mobility of thermal ions in the kinetic regime. The actual structure of helium ions leads to the fact that the scattering cross sections of different thermal and impurity excitations by ions are extremely varied. In this connection each of the scattering mechanisms -- phonon, scattering of impurities in weak $\text{He}^3\text{-He}^4$ solutions, fermi-liquid and roton mechanisms -- (arranged in order of increasing complexity of interpretation) requires special discussion. The author mentions the theoretical successes in interpretation of the corresponding forms of kinetic mobility of helium ions, and also the typical difficulties that impede the construction of a new complete theory of kinetic mobility of helium ions. Chapter 3 contains results of the investigation of mobility of helium ions under conditions of existence of the hydrodynamic approximation in dense gaseous helium and in solid helium. The author thanks A. F. Andreyev and L. P. Mezhev-Deglin for numerous discussions on the topic of this survey, and also K. O. Keshishev for making available experimental data on the mobility of ions in solid helium as given in his dissertation. References 99: 39 Russian, 60 Western.

USSR

THE MOVEMENT OF A GAS BEYOND A FLAT DETONATION WAVE MOVING THROUGH A CYLINDER OF EXPLOSIVE

Novosibirsk FIZIKA GORENIYA I VZRYVA in Russian Vol 12 No 6, Nov/Dec 76 pp 930-935 manuscript received 7 Jul 75

DVORNIKOV, V. A., and KOMAROVSKIY, L. V., Scientific Research Institute for Applied Mathematics and Mechanics, Tomsk State University

[Abstract] A study is made of the process of dispersal of detonation products formed upon initiation of a cylinder of explosive at one end out into a vacuum. Chapman-Jouguet detonation conditions are assumed. A comparison is made with the results upon detonation of a quarter space filled with explosive and initiated on one face. Prandtl-Mayer flow is established at the edge of the cylinder with critical velocity of the incoming flow. Comparison of regions of dispersal indicates that the axisymmetrical effect is not reflected in the shape of the free flight boundary, in the distribution of gas parameters at the edge of the cylinder or on the shape of the one-dimensional region, and in general occurs only in the central portion of the region of the lateral rarefaction wave. Figures 3; references 5 (Russian).

USSR

CALCULATION OF THE CONDITIONS OF INTERRUPTION OF COMBUSTION BEYOND A FLAT STEP AND IN A DEPRESSION AROUND WHICH A SUPERSONIC STREAM OF A HYDROGEN-AIR FUEL MIXTURE FLOWS

Novosibirsk FIZIKA GORENIYA I VZRYVA in Russian Vol 12 No 6, Nov/Dec 76 pp 871-879 manuscript received 30 Sep 75

MESHCHERYAKOV, YE. A., and MAKASHEVA, O. V., Central Aerohydrodynamics Institute, Moscow

[Abstract] A study is made of the combustion of hydrogen fuel. In contrast to earlier works, which utilized the summary kinetics of the combustion of hydrocarbons, the full kinetics of the combustion of hydrogen in air is used, including eight reactions for seven components. The theory of isothermal reactors in combination with elements of the theory of turbulent streams and the theory of Korst are used to calculate the flow parameters when combustion is interrupted in recirculation zones beyond a flat step and in a depression in a supersonic homogeneous hydrogen-air fuel mixture. The calculations utilize a method which allows the influence of various geometric and mode parameters on the boundaries of stability of operation of combustion stabilizers of this type to be traced. References 11: 8 Russian, 3 Western.

USSR

THE ELECTRIC FIELD OF A LAMINAR FLAME WITH A HIGH DEGREE OF IONIZATION

Novosibirsk FIZIKA GORENIYA I VZRYVA in Russian Vol 12 No 6, Nov/Dec 76 pp 865-871 manuscript received 8 Sep 75

KIDIN, N. I., and MAKHVILADZE, G. M., Institute of Mechanical Problems, Academy of Sciences USSR, Moscow

[Abstract] A study is made of the natural electrical properties of a highly ionized laminar flame propagating in a mixture of premixed fuel gases. A closed system of equations describing the diffusion of charged particles and Poisson's differential equation are used to calculate the distributions of charged particles and intensity of the internal electric field that arises due to the difference in diffusion capacities of electrons and ions. The authors investigate the influence that recombination has on the maximum electric field strength of a laminar flame. It is found that the field strength changes sign with transition from the heating zone to the reaction product region, and that the maximum [in absolute value] occurs in the heating zone. Experimental confirmation of the results requires measurement of the distribution of electric field intensity and charged particle concentration at the flame front. This type of measurement for a spherical flame front propagating through a mixture of $2H_2+O_2+6M_2+0.005CH_4$ has been performed. The authors thank V. B. Librovich, V. I. Myshenkov and G. I. Shapiro for constructive discussions and comments. Figure 1; references 11: 5 Russian, 1 Polish, 5 Western.

USSR

LOW-FREQUENCY STABILITY OF THE COMBUSTION OF CONDENSED SYSTEMS WITH RAPIDLY BURNING ELEMENTS

Novosibirsk FIZIKA GORENIYA I VZRYVA in Russian Vol 12 No 6, Nov/Dec 76 pp 845-854 manuscript received 6 Jun 75

RUDNEV, A. P., Scientific Research Institute for Applied Mathematics and Mechanics of Tomsk State University

[Russian abstract provided by the source]

[Text] In this work, within the limits of the phenomenological theory of unsteady combustion of powders, a study is made of the low-frequency stability of combustion of combined condensed systems, utilizing a cylinder of finite thickness, a rod and a plate as rapidly burning elements. Calculations show that for the investigated structure of the combustion system and chamber with incomplete energy liberation of at least one of the components of the condensed system, in the general case several steady states of combustion are possible and there are limits of combustion with respect to pressure. Depending on

the relationship of the geometric and energy characteristics of the components of the combustion system, a reduction in thickness or density of rapidly burning elements can stabilize or destabilize the combustion mode. Figures 3; references 22: 10 Russian, 12 Western.

USSR

THE INFLUENCE OF HETEROGENEITY OF INTERNAL STRUCTURE OF A MEDIUM ON COMBUSTION OF CONDENSED MIXTURES OF REAGENTS INTERACTING THROUGH A LAYER OF A PRODUCT

Novosibirsk FIZIKA GORENIYA I VZRYVA in Russian Vol 12 No 6, Nov/Dec 76 pp 819-827 manuscript received 23 Jun 75

ALDUSHIN, A. P., KHAYKIN, B. I., and SHKADINSKIY, K. G., Institute of Chemical Physics, Chernogolovka

[Abstract] An analysis is presented of the influence of heterogeneity of the internal structure of a medium on the combustion of heterogeneous condensed systems interacting through a product layer. The mixture is looked upon as a polydispersed mixture with a certain size distribution of particles, and this model is used to analyze the influence of heterogeneities of the internal structure on propagation of the combustion process. The significance of polydispersion of the mixture for combustion is analyzed using a parabolic rule of interaction among the components. It is shown that the structure of the leading edge of the combustion wave depends on the nature of the spectrum of scales of heterogeneities. Based on the results, experimental data on the combustion of a Ti-C system are analyzed. It is considered that structural heterogeneity not only exists in an initial sample, but also may arise during the process of combustion due to differences in melting points of components, etc. The authors thank T. M. Martem'yanova for assistance with the numerical calculations. Figures 7; references 9 (Russian).

USSR

UDC 533.6.011

ON THE THEORY OF AXISYMMETRIC SUPERSONIC GAS FLOW AROUND A SHARP SOLID OF REVOLUTION

Moscow PRIKLADNAYA MATEMATIKA I MEKHANIKA in Russian Vol 41 No 1, Jan/Feb 77 pp 186-188 manuscript received 16 May 75

BULAKH, B. M., Leningrad

[Abstract] The author considers axisymmetric steady-state supersonic flow of an inviscid gas around a sharp solid of revolution having a non-zero curvature of the meridional curve at the vertex. It is shown that the derivatives with respect to $\zeta = n/s$ (n is the distance from the vertex along the meridional curve, s is the distance along the normal to the surface) of the specific entropy $S = S(s, \zeta)$ and the tangential component of the velocity of the gas particles $u = u(s, \zeta)$ close to the surface of the solid have order $\zeta^{-1/2}$, i.e., the surface of the body is singular. Figure 1; reference 1 (Russian).

USSR

UDC 532.516:62-505

OPTIMUM CONTROL OF A FLOW OF NON-NEWTONIAN FLUID BETWEEN ROTATING CYLINDERS

Moscow PRIKLADNAYA MATEMATIKA I MEKHANIKA in Russian Vol 41 No 1, Jan/Feb 77 pp 113-123 manuscript received 16 Sep 75

YELIZAROV, V. I., and SIRAZETDINOV, T. K., Kazan'

[Abstract] The authors consider the problem of motion of a non-newtonian fluid in a gap between cylinders of radius R in contrary rotation with peripheral velocity U . It is assumed that the minimum gap $2H_0$ is small compared with the radius ($R \gg 2H_0$). The geometry of the problem is shown in the diagram

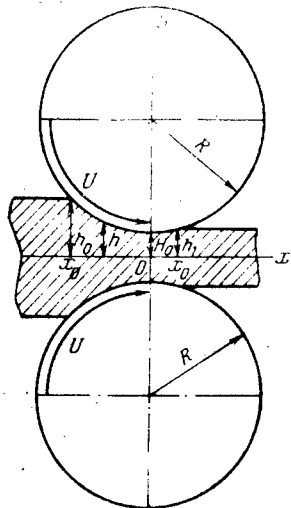

It is assumed that fluid flow in the gap is laminar, that gravitational and inertial forces are negligible compared with forces of friction, and that hydrostatic pressure varies only in the direction of motion of the fluid, which adheres to the surface of the cylinders in the flow region. Motion of the fluid is symmetric relative to Ox . The problem is solved for the case of maximum fluid flowrate assuming a given output of rolled items. Figures 5; tables 2; references 9: 8 Russian, 1 Western.

USSR

UDC 533.6.011.7

SOME ASYMPTOTIC PROPERTIES OF MACROPARAMETERS OF A RAREFIED GAS AS IT EXPANDS INTO A VACUUM

Moscow PRIKLADNAYA MATEMATIKA I MEKHANIKA in Russian Vol 41 No 1, Jan/Feb 77 pp 72-78 manuscript received 6 Jul 76

ZHUK, V. I., Moscow

[Russian abstract provided by the source]

[Text] The author considers the problem of dispersion of a plane layer of maxwellian gas into a vacuum. The expansion with respect to Knudsen numbers contains a logarithmic singularity at large elapsed times, which is removed by slight stretching of the time coordinate. An asymptotic solution is constructed that describes the long-range flow field in a planar steady-state jet for Knudsen numbers that approach zero.

A previous investigation of plane dispersion of a finite mass of rarefied gas into a vacuum at small initial Knudsen numbers showed that disruption of the continuous-medium regime occurs at times of the order of $Kn^{-\sigma}$, $\sigma = 3/2 (1 - \nu)^{-1}$, assuming power-law temperature dependence of viscosity $\mu = T^\nu$. In this paper the author investigates the special case of $\nu = 1$, where a uniformly valid solution can be found by Lighthill's method of deformed coordinates. References 8: 3 Russian, 5 Western.

USSR

UDC 533.6.011

ON HYPERSONIC AXISYMMETRIC FLOW WITH CONSTANT MOMENT OF MOMENTUM

Moscow PRIKLADNAYA MATEMATIKA I MEKHANIKA in Russian Vol 41 No 1, Jan/Feb 77
pp 65-71 manuscript received 2 Jun 76

TERENT'YEV, YE. D., Moscow

[Russian abstract provided by the source]

[Text] The author examines axisymmetric hypersonic flow at great distances from a body in the flow. Flow behind the body is broken down into three regions: a region of shock wave structure, external ideal flow, and a laminar viscous heat-conductive wake. An investigation is made of perturbations associated with a constant moment of momentum directed along the axis of symmetry. The constructed perturbations are localized in the wake and damp out exponentially with transition to the external region. Figure 1; references 15: 11 Russian, 1 Polish, 3 Western.

USSR

UDC 533.6.011

USE OF NONLINEAR PROGRAMMING METHODS TO SOLVE VARIATIONAL PROBLEMS IN GAS-DYNAMICS

Moscow PRIKLADNAYA MATEMATIKA I MEKHANIKA in Russian Vol 41 No 1, Jan/Feb 77
pp 59-64 manuscript received 6 May 76

BUTOV, V. G., VASENIN, I. M., and SHELUKHA, A. I., Tomsk

[Abstract] A method of solving variational problems in gasdynamics is proposed that is based on reducing them to problems of nonlinear programming. The main components of the computational algorithm are direct calculations of the field of gas flow and a method of searching for the extremum of a function of many variables. The peculiarities of application of the method are examined on the basis of examples of solution of variational problems on design of supersonic nozzle contours for maximum thrust, and the problem of constructing a nozzle with a flat transition surface. The authors thank A. N. Krayko for interest in the work, and A. D. Rychkov who furnished a program for calculating subsonic flows. Figures 3; references 8: 5 Russian, 3 Western.

SECONDARY INCREASE OF BASE PRESSURE IN COMBUSTION BEHIND AN AXISYMMETRIC BODY IN A SUPERSONIC FLOW

Novosibirsk FIZIKA GORENIYA I VZRYVA in Russian Vol 13 No 1, Jan/Feb 77 pp 125-129 manuscript received 22 Dec 75

BAYEV, V. K., VUYTITSKIY, S. A., GARANIN, A. F., TRET'YAKOV, V. P., and YASAKOV, V. A., Institute of Theoretical and Applied Mechanics, Siberian Department of the Academy of Sciences USSR, Novosibirsk

[Russian abstract provided by the source]

[Text] An experimental study is done on the effect that hydrogen combustion has on the base pressure behind an axisymmetric body in a supersonic wind tunnel at Mach numbers of 2 and 2.5. It is shown that heat release behind an axisymmetric body in such a tunnel may lead to a secondary increase of base pressure. An increase in the hydraulic drag of the tunnel ducting leads to a secondary increase of base pressure with less heat release. Figures 4; references 5: 4 Russian, 1 Western.

INITIATION OF LIQUID EXPLOSIVES BY LOW-AMPLITUDE SHOCK WAVES

Novosibirsk FIZIKA GORENIYA I VZRYVA in Russian Vol 13 No 1, Jan/Feb 77 pp 97-102 manuscript received 4 Oct 76

GONCHAROV, A. A., DUBOVIK, A. V., and BOBOLEV, V. K., Institute of Chemical Physics, Academy of Sciences USSR, Moscow

[Abstract] Experiments are done on excitation of a chemical reaction in explosive liquids that contain cavitation bubbles. The experimental setup is shown in the diagram.

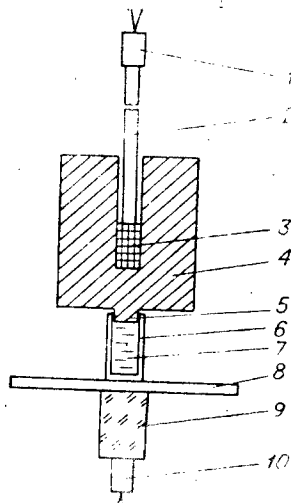

1, 10--standard blasting caps; 2--fuse; 3--active charge of explosive with mass of 2 g, density of 1.2 g/cc; 4--steel sleeve 25 mm high, 60 mm in diameter with wall thickness of 25 mm with a cylindrical cavity 10 mm in diameter and 60 mm deep [sic]; 5--sleeve tip 12 mm in diameter and 5 mm high with 3 mm immersed in the liquid explosive; 6--glass cylinder 13 mm in diameter and 30 mm high with wall thickness of 1.5 mm; 7--liquid explosive (4 ml); 8--aluminum shield plate measuring 100 x 100 mm and 5 mm thick; 9--Plexiglas damper rod 20 mm in diameter and 30 mm high.

The shock wave produced by blasting cap 10 passes through the damper rod and shield plate and generates cavitation in the liquid explosive. When the cavitation zone reaches the upper edge of the cylinder, the shock wave from the sleeve tip propagates into the liquid, collapsing the bubbles and starting a chemical reaction if its amplitude surpasses some critical value. Synchronization is achieved by proper selection of the fuse length. The recording instrumentation is described. The explosives studied were nitromethane, tetranitromethane mixed with gasoline in 90/10 and 93/7 ratios, tetranitromethane mixed with nitromethane in a 67/33 ratio, tetranitromethane alone, nitroglycerin, dinitrate bis-methylolfulfoxan and diethylene glycol dinitrate. It was found that nitromethane and tetranitromethane alone have low shock wave sensitivity--shock waves with amplitude of 30-50 kbar are required for detonating these liquids in the cavitation state. Diethylene glycol dinitrate is initiated by moderately strong shock waves with amplitude between 5 and 20 kbar. The other explosives are highly sensitive to shock wave initiation, being detonated by pressures of 1-5 kbar. Figures 3; tables 2; references 10: 7 Russian, 3 Western.

USSR

UDC 532.593

DECOMPOSITION OF CAST TNT IN SHOCK WAVES

Novosibirsk FIZIKA GORENIYA I VZRYVA in Russian Vol 13 No 1, Jan/Feb 77 pp 85-92 manuscript received 18 Nov 75

KANEL', G. I., and DREMIN, A. N., Division of the Institute of Chemical Physics, Academy of Sciences USSR, Chernogolovka

[Russian abstract provided by the source]

[Text] The evolution of the pressure profile is studied as a one-dimensional shock wave with initial amplitude of 66 kbar propagates in cast TNT. Trajectories of the change in state of the layers of the specimen are plotted in coordinates of pressure vs. mass velocity and pressure vs. degree of compression, and the time dependence of concentration of explosion products is determined. An empirical kinetic equation is proposed to describe the law of decomposition of cast TNT under conditions of impact compression; this expression is suitable for rough calculations over a wide range of shock wave intensities. The authors thank G. A. Savel'yeva for her help in setting up and carrying out the experiments. Figures 10; table 1; references 12: 9 Russian, 3 Western.

DETONATION OF TUBULAR EXPLOSIVE CHARGES IN LIQUID HYDROGEN

Novosibirsk FIZIKA GORENIYA I VZRYVA in Russian Vol 13 No 1, Jan/Feb 77 pp 78-84 manuscript received 24 Dec 75

SIL'VESTROV, V. V., and URUSHKIN, V. P., Institute of Hydrodynamics, Siberian Department, Academy of Sciences USSR, Novosibirsk

[Abstract] An investigation is done on the reasons for increased detonation rate of a tubular charge filled with liquid hydrogen for explosives with initiation threshold from 2 to 25 kbar--PETN, RDX and TG 50/50. A diagram of the experimental installation is shown in the figure.

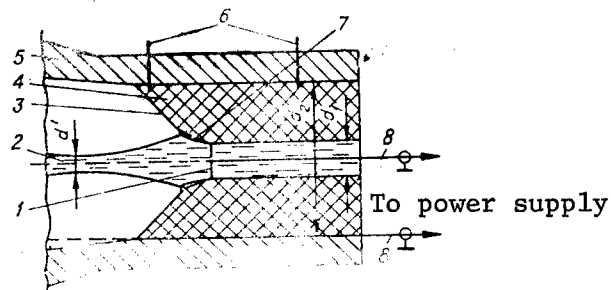

The explosive charge 4 is initiated by a plane-wave generator placed in a Dural shell 5 to increase the efficiency of energy transfer from the explosive to shock-compressed liquid hydrogen 2. To keep continuous track of the densities and velocities of the detonation and channel waves, rheostat sensors 8 were used, based on a nickel capillary 0.04 cm in diameter. In addition, ionization probes 6 were used for checking the rate of detonation. It was found that a flow arises in the channel that exceeds the normal detonation rate, leading to the formation of lateral conical compression wave 7 in the explosive, which appreciably influences the nature of the detonation process. The authors thank A. M. Mardashev for a number of numerical calculations used in the paper, and N. N. Gorshkov for making the rheostat sensors. Figures 4; tables 2; references 14: 9 Russian, 5 Western.

USSR

UDC 534.222.2

CALCULATION OF THE DEVELOPMENT OF DETONATION WAVES

Novosibirsk FIZIKA GORENIYA I VZRYVA in Russian Vol 13 No 1, Jan/Feb 77 pp 69-77 manuscript received 23 Feb 76

FORTOVA, T. N., SHKADINSKIY, K. G., DREMIN, A. N., and FORTOV, V. YE., Division of the Institute of Chemical Physics, Academy of Sciences USSR, Chernogolovka

[Abstract] The paper gives the numerical calculation of unsteady hydrodynamic effects when a plane shock wave initiates detonation in a condensed explosive. Models are proposed for experimentally observed modes of development of detonation waves. On the basis of the experimental data, parameters are selected that appear in the kinetic equation describing detonation of TNT. It is concluded that chemical reactions are excited by a thermal mechanism when detonation is initiated by a shock wave of high dynamic pressure. The resultant hydrodynamic effects can be formally described by a macrokinetic Arrhenius equation with experimentally determined constants. A more detailed quantitative description of experimental data would require better developed kinetic models. Numerical modeling and comparison with experiment enable a deeper and more complete investigation of both the mechanism of detonation transformation and the quantitative characteristics of this transformation. The authors thank S. A. Koldunov and K. K. Shvedov for construction discussions. Figures 6; references 23: 20 Russian, 3 Western.

USSR

UDC 566.468+532.5

THE PART PLAYED BY STEFAN FLOW IN HETEROGENEOUS IGNITION OF A SYSTEM OF TWO SEMI-INFINITE FUEL AND OXIDANT MEDIA

Novosibirsk FIZIKA GORENIYA I VZRYVA in Russian Vol 13 No 1, Jan/Feb 77 pp 29-32 manuscript received 5 Jan 76

ROZENBAND, V. I., and MARTEM'YANOVA, T. M., Division of the Institute of Chemical Physics, Academy of Sciences USSR, Chernogolovka

[Russian abstract provided by the source]

[Text] The paper gives a numerical solution for the problem of ignition of two semi-infinite media of gaseous oxidant and condensed fuel when an exothermal chemical reaction takes place on the interface with consideration of the influence of Stefan flow on the ignition process. It is shown that Stefan flow has a considerable effect on delay of ignition and on the combustion boundary. Figures 2; table 1; references 11: 8 Russian, 3 Western.

USSR

UDC 536.46+541.126+662.311

CONDITIONS OF LOW-FREQUENCY STABILITY OF THE COMBUSTION OF POWDER IN THE PRESENCE OF INJECTION AND SWIRLING OF GASES IN A SEMICLOSED CHAMBER

Novosibirsk FIZIKA GORENIYA I VZRYVA in Russian Vol 13 No 1, Jan/Feb 77 pp 44-48 manuscript received 27 Apr 76

VILYUNOV, V. N., and RUDNEV, A. P.

[Russian abstract provided by the source]

[Text] An averaged system of equations is formulated that describes unsteady combustion of powder in a vortex injection system in the phenomenological approximation of powder combustion. Conditions of cutoff of combustion in the quasi-steady state approximation are found in the linear approximation; the same conditions are found in the linear approximation with consideration of the times of relaxation of the chamber and the heated fuel layer. The limits of combustion stability are calculated, and a number of qualitative conclusions are drawn from the results of the study. Figure 1; references 13: 12 Russian, 1 Western.

USSR

UDC 533.6.011+533.697

SHOCK STARTING OF AN OVEREXPANDED SUPERSONIC NOZZLE

Moscow DOKLADY AKADEMII NAUK SSSR in Russian Vol 233 No 1, 1 Mar 77 pp 93-96 manuscript received 4 Jun 76

GVOZDEVA, L. G., and ZHILIN, YU. V., Institute of High Temperatures, Academy of Sciences USSR, Moscow

[Abstract] Experiments were done on shock starting of an overexpanded supersonic nozzle in a single-diaphragm square shock tube (72 x 72 mm) with a flat nozzle installed in the end. Nitrogen, air and a mixture of 10% CO₂, 40% N₂ and 50% He were investigated. Initial pressures ranged from 10 to 150 mm Hg, and Mach numbers of the incident shock wave from 2 to 6. Nozzles were studied with vertex half-angle of 5, 15 and 30°, nozzle height at the tip of 22, 35 and 72 mm, and height of the critical cross section of 4.2 and 6 mm. The process was analyzed from Töpler spark patterns and slit-scan photographs taken along the axis of the nozzle. It was found that as the Mach number of the incident shock wave decreases and as the ratio between the areas of the nozzle tip and the critical cross section increases, a jet forms inside the nozzle. This jet is formed by interaction between the reversed shock wave and the boundary layer. This interaction process determines starting conditions: starting is not possible under conditions where a jet can form. The trajectories of the starting wave, contact surface and reversed wave were determined from the experimental material. The experimental results are compared with theory. Figures 3; references 9: 1 Russian, 1 Polish, 7 Western.

USSR

UDC 621.375.826:535.21

MECHANISM OF DEVELOPED EVAPORATION OF GLASS UNDER THE INFLUENCE OF LASER RADIATION

Moscow KVANTOVAYA ELEKTRONIKA in Russian Vol 4 No 3, Mar 77 pp 641-644 manuscript received 27 Apr 76

BELEZEROV, S. A., ORLOV, A. A., and ULYAKOV, P. I.

[Abstract] A mechanism is suggested for the developed evaporation of gas, based on reradiation of light in the evaporated substance, which explains the basic experimentally observed regularities of the process. The effects related to the initial stage of absorption of laser radiation in a transparent dielectric require special analysis and are not included in this article. The basic experimental results were produced by studying the effect on type K8 optical glass of free emission pulses 1.5 ms in length with a light beam divergence of $3 \cdot 10^{-3}$. The laser radiation was focused on the front edge of a polished specimen in a spot 0.2 mm in radius. The process of development of craters was studied by high speed photomicrography. The experiments established a linear dependence between rate of evaporation and light flux. Experimental and theoretical values agree within 30%. The authors thank Yu. P. Rayzer for discussing the work. Figures 2; references 9: 8 Russian, 1 Western.

USSR

UDC 621.375.826

A STUDY OF PULSED LASER EMISSION ON GOLD VAPOR

Moscow KVANTOVAYA ELEKTRONIKA in Russian Vol 4 No 3, Mar 77 pp 614-618 manuscript received 15 Jun 76

MARKOVA, S. V., and CHEREZOV, V. M., Institute of Physics imeni P. N. Lebedev, Academy of Sciences USSR, Moscow

[Abstract] Stimulated emission of pulses in gold vapor in the visible and UV regions of the spectrum is studied in discharges with various buffer gases: helium, neon, argon and xenon. All studies were performed on an installation containing a discharge tube, power supply providing the necessary pumping mode, and system for recording of radiation. A corundum tube with an i.d. of 16 mm, 65 cm in length, was used. The metal was placed directly on the wall of the tube. The studies were performed in the self-heating mode. The buffer gases were used to protect the apertures from contamination by diffusion of gold vapor and to maintain the discharge in the cold tube. For the mixture with neon, a mean radiated power in the visible region of 2.1 W was produced with an efficiency of 0.15%, the UV region--about 0.2 W. These results make this laser equivalent to such effective systems as lasers operating on vapors of barium, lead and manganese. The authors thank G. G. Petrash for valuable advice during the work and discussion of results. Figures 4; tables 2; references 4: 3 Russian, 1 Western.

PARAMETERS OF CALCIUM AND TITANIUM PLASMA WITH VARIOUS LASER RADIATION FOCUSING GEOMETRIES

Moscow KVANTOVAYA ELEKTRONIKA in Russian Vol 4 No 3, Mar 77 pp 607-613 manuscript received 14 Jun 76

ILYUKHIN, A. A., PEREGUDOV, G. V., and RAGOZIN, YE. N., Institute of Physics imeni P. N. Lebedev, Academy of Sciences USSR, Moscow

[Abstract] An experimental comparison is done on three geometrically different methods of focusing laser radiation: sharp focusing using a spherical lens ($f \approx 300$ mm), focusing in a circle with a diameter of ~ 1.4 mm and focusing on a line by means of a two-component lens consisting of a spherical component ($f \approx 300$ mm) and a plano-convex cylindrical component ($f \approx 300$ mm). The far vacuum ultraviolet spectra of calcium and titanium plasmas produced with these three methods of focusing of the laser radiation on a planar target are compared. The titanium spectra are produced with spatial resolution in the direction perpendicular to the target. The relative intensities of $2s2p^{n+1}-2s^22p^n$ ion transitions, isoelectronic with F, O, N and C atoms, are used to determine the ionic composition and ionization temperature T_z . The concentration of the Ne-like ion is estimated by extrapolation. For titanium, the ionic composition is determined as a function of distance to the target. The glow of the plasma is limited significantly less with respect to the height of the region for line focusing than for the other two cases of focusing. The authors thank I. I. Sobel'man for interest in the work and comments, Ye. A. Yukov for assistance in calculating the atomic characteristics, V. A. Chirkov for cooperation with the experiment, V. A. Boyko for constructive discussions, M. R. Shpol'skiy and N. V. Uvarova for furnishing sensitive photographic film, and B. N. Chichkov for assistance in analyzing the titanium spectrograms. Figures 3; tables 4; references 11: 8 Russian, 3 Western.

USSR

UDC 621.375.826+621.039.66+523.77+621.039.67

ANALYSIS OF THE INTENSITY OF RESONANCE LINE SATELLITES OF HYDROGEN-LIKE IONS IN A LASER PLASMA

Moscow KVANTOVAYA ELEKTRONIKA in Russian Vol 4 No 3, Mar 77 pp 600-606 manuscript received 6 Jun 76

BOYKO, V. A., PIKUZ, S. A., SAFRONOVA, U. I., and FAYENOV, A. YA., Institute of Physics imeni P. N. Lebedev, Academy of Sciences USSR, Moscow

[Russian abstract provided by the source]

[Text] The intensities of spectral lines of the satellite structure of the L_{α} resonance doublet of hydrogen-like ions with nuclear charges $Z=12-16$ corresponding to transitions with doubly excited auto-ionization levels of helium-like ions are analyzed. Analysis of the $1s2l'-2l2l'$ and $1s3l'-2l3l'$ transitions allows full interpretation of laser plasma spectra observed with a flux density of the heating radiation of $\sim 10^{14}$ W/cm², and shows good agreement between theoretical and experimental data with the exception of the intensities of the line with $\lambda=8.5305$ Å in the spectrum of Mg. The authors thank N. G. Basov and O. N. Krokhin for interest in the work, and L. A. Vaynshteyn, A. V. Vinogradov, G. V. Sklizkov, I. Yu. Skobelev and Ye. A. Yukov for useful discussions. Figures 3; tables 3; references 21: 19 Russian, 2 Western.

USSR

UDC 621.3.038.8:535.21

INFLUENCE OF ADSORBED WATER ON RADIATION STRENGTH OF IR OPTICS ELEMENTS

Moscow KVANTOVAYA ELEKTRONIKA in Russian Vol 4 No 3, Mar 77 pp 587-595 manuscript received 21 May 76

KOVALEV, V. I., and FAYZULLOV, F. S., Institute of Physics imeni P. N. Lebedev, Academy of Sciences USSR, Moscow

[Abstract] Spectroscopic and mass spectroscopic methods are used to study the composition of matter emitted by the surface of polished transparent IR materials under the influence of pulsed CO₂ laser radiation. It is shown that the basic components of these substances are water, hydroxyl and the material of the specimen. Laser cleaning results in a decrease in the quantity of water and hydroxyl, leading to an increase in the breakdown threshold at the surface. The breakdown threshold at a surface free of adsorbed water (fracture surface produced in a vacuum) is equal to the threshold of volumetric failure of the material of the specimen. The authors study the dynamics of the development of a breakdown plasma at the surface and measure the plasma temperature. Possible means for increasing the radiation strength of the surfaces of IR optical elements by decreasing adsorption properties of the surface are studied. Using the examples of NaCl specimens, it is shown that chemical etching of a

mechanically polished surface can increase the breakdown threshold by 5-6 times for a short period of time (5 minutes) and 2.5-3 times for a long period (at least 3 months). The effect produced by laser cleaning is essentially one of high temperature annealing of the surface by the breakdown plasma. The authors thank B. Sh. Ul'masbayev and A. I. Busygin for doing the mass-spectrometric analysis, and V. B. Fedorov for assistance. Figures 8; references 16: 11 Russian, 5 Western.

USSR

UDC 621.378.324

STUDY OF THE ELECTRIC DISCHARGE CHAMBER OF A RAPID-FLOW CO₂ LASER

Moscow KVANTOVAYA ELEKTRONIKA in Russian Vol 4 No 3, Mar 77 pp 581-586 manuscript received 15 May 76

ARTAMONOV, A. V., BLOKHIN, V. I., VEDENOV, A. A., VITSHAS, A. F., GAVRILYUK, V. D., YEGOROV, A. A., NAUMOV, V. G., PASHKIN, S. V., and PERETYAT'KO, P. I.

[Abstract] Results are presented from an experimental study of the electric discharge chamber of a rapid-flow CO₂ laser operating with a mixture of air and CO₂. The possibility is shown of increasing the pressure of the molecular gas in the discharge to 100-130 mm Hg while conserving a sufficiently high specific energy density. It is found that there is an optimal distance between the cathode elements and that the energy density is not additive upon increasing chamber size in the direction of flow. Equations relating the maximum energy density to gas pressure, velocity and length of discharge zone are presented. Heating of the gas determines the upper pressure limit of use of discharge chambers of the type studied operating with air. The effectiveness of the discharge chamber can be significantly increased by using nitrogen or dry air as the working medium. The necessary quantity of water (or other additive) to populate the lower laser level of the CO₂ molecule can be added to the flow immediately before the resonator zone. Figures 7; table 1; references 7: 5 Russian, 2 Western.

USSR

UDC 621.373:535

FREQUENCY CHARACTERISTICS OF A TWO-MODE GAS RING LASER WITH TWO-ISOTOPE ACTIVE MEDIUM

Moscow KVANTOVAYA ELEKTRONIKA in Russian Vol 4 No 3, Mar 77 pp 567-574 manuscript received 18 May 76

DOKOLOV, V. A., and FRADKIN, E. YE., Scientific Research Institute for Physics, Leningrad State University

[Abstract] A study is made of four-wave two-mode synchronized emission for waves with identical linear polarizations in an equal-isotope (50%:50%) active gas medium. The region of existence of this emission depends on the losses in oppositely directed waves, the back scattering coefficients of the waves, the lengths of the tubes containing the active medium and their placement relative to each other, while the region of stability of emission depends on the pressure of the gas medium, the perimeter of the resonator, the length of the tubes containing the active medium and their mutual placement. In the study of the frequency characteristics of the ring laser presented in this work, the diffraction splitting of frequencies of back waves and radiation capture are not considered; the polarization of the two modes is considered identical and linear. Figures 4; references 7 (Russian).

USSR

UDC 621.372.826

DISTRIBUTED FEEDBACK IN LASERS DUE TO PARAMETRIC INTERACTION: UNSTEADY EFFECTS AND THE NONLINEAR MODE

Moscow KVANTOVAYA ELEKTRONIKA in Russian Vol 4 No 3, Mar 77 pp 556-566 manuscript received 17 Mar 76

AKHMANOV, S. A., LYAKHOV, G. A., and SUYAZOV, N. V., Moscow State University

[Abstract] A theoretical analysis is presented of a laser system with distributed feedback provided by parametric interaction of waves in a nonlinear medium. Threshold emission conditions are found in such a system considering the incomplete spatial coherence and nonmonochromatic nature of pumping. The time characteristics of the counter wave emission pulse are calculated with small excess over the threshold, as well as the coefficient of nonlinear transformation of parametric pumping into the power of the signal and zero-load waves in steady-state emission. It is determined that the four-photon interaction can be used in inorganic laser liquids in which amplification achieved is of the same order of magnitude as in neodymium glass. The most interesting possibility is that of producing a counter wave laser in thin film wave guides. However, the non-waveguide perpendicular pumping suggested in this work must have high spatial coherence. Liquid crystal materials are quite interesting,

particularly in connection with the ease of fulfilling the conditions of synchronism over a broad frequency range, although their use involves certain technological difficulties. Figures 5; references 14: 10 Russian, 4 Western.

USSR

UDC 621.372.833.1

OPTICAL PROCESSES IN THIN-FILM LASERS AND WAVEGUIDES WITH ARBITRARY DISTRIBUTION OF INDEX OF REFRACTION

Moscow KVANTOVAYA ELEKTRONIKA in Russian Vol 4 No 3, Mar 77 pp 544-555 manuscript received 25 Jun 76

KISELEV, V. A., and PROKHOROV, A. M., Physics Institute imeni P. N. Lebedev, Academy of Sciences USSR, Moscow

[Russian abstract provided by the source]

[Text] A theory is developed for flat waveguide systems with arbitrary distribution of index of refraction over the transverse cross section, which describes the diffraction transformations of surface waves to other surface waves and to radiated waves in the case when one of the boundaries between the dielectric layers making up the waveguide is weakly modulated in accordance with a sine-wave law. The theory encompasses diffraction processes of first and second orders. Diffraction radiation of surface H and E waves and resonant mutual conversions of these waves in the first order of diffraction are analyzed in detail. In particular, conditions of generation of H and E waves in thin film lasers with distributed feedback and arbitrary transverse distribution of the index of refraction are formulated. Figures 2; references 6: 4 Russian, 2 Western.

USSR

UDC 621.371.255

TURBULENT DISTORTIONS OF SPATIAL COHERENCE OF A LASER BEAM

Moscow KVANTOVAYA ELEKTRONIKA in Russian Vol 4 No 3, Mar 77 pp 517-523 manuscript received 12 Apr 76

BELEN'KIY, M. S., KON, A. I., and MIRONOV, V. L., Institute of Atmospheric Optics, Siberian Affiliate, Academy of Sciences USSR, Tomsk

[Abstract] This work presents a study of the spatial coherence of single-mode and multiple-mode laser radiation after transmission through a layer of turbulent atmosphere as a function of the turbulent characteristics of the medium, the coherent properties of the source, the diffraction size of the radiating atmosphere and the beam focusing parameter. The results are used to solve the problem of turbulent erosion of the image of a partially coherent source in the focal plane of the receiving lens. It is established that the radius of spatial coherence of the field of a single-mode laser beam exceeds the value corresponding to plane and spherical waves. The excess is greatest with strong fluctuations in intensity when the condition $\lambda_0 \ll \lambda \ll \lambda_0^{-1}$ is fulfilled. A similar effect occurs in the case of a partially coherent source. The radius of coherence of a single-mode beam, focused in the plane of observation ($x=f$) in a turbulent medium where $\lambda \gg \lambda_0^{-1} \gg 1$ is close to its diffraction dimension and coincides with the radius of coherence of the radiation of a thermal source of the same size at distance x in a vacuum. As the effective turbulent thickness of the medium (parameter β^2_0) increases, the dependence of radius of coherence on coherence of the initial field and diffraction dimension of the source disappears. Figures 3; references 17: 12 Russian, 5 Western.

USSR

UDC 621.37.32

THE METAL-DIELECTRIC TRANSITION WITH IMPULSE EVAPORATION OF METALS UNDER THE INFLUENCE OF OPTICAL RADIATION

Moscow KVANTOVAYA ELEKTRONIKA in Russian Vol 4 No 3, Mar 77 pp 524-530 manuscript received 29 Apr 76

KOZLOV, B. M., SAMOKHIN, A. A., and USPENSKIY, A. B., Physics Institute imeni P. N. Lebedev, Academy of Sciences USSR, Moscow

[Abstract] Possible manifestations of metal-dielectric transitions with unsteady vaporization of metals under the influence of intensive optical radiation are discussed. It is shown that a sharp decrease in coefficient of absorption leads to the appearance of a horizontal section on the recoil pressure curve $p(t)$ immediately before the beginning of explosive decomposition of the metastable state of the superheated liquid phase. The possibility is

noted of an increase in transparency of metal targets under the influence of intensive optical radiation not directly related to the metal-dielectric transition. The reason is that the metal target is "transparent" for the natural radiation of the high temperature plasma which arises upon interaction of the laser radiation with the target surface. With sufficient volumetric energy liberation density, volumetric heating and explosive decomposition of the metastable state are possible in the condensed phase, resulting from short wave plasma radiation. This effect must be considered as one mechanism of formation of comparatively deep craters observed when metals are struck by giant laser radiation pulses with intensities on the order of 10^{10} W/cm². The authors thank S. D. Kaytmazov and Ye. I. Shklovskiy for constructive criticism. Figures 3; references 22: 20 Russian, 2 Western.

USSR

UDC 535.375

MEANS FOR INCREASING THE EFFICIENCY OF SOLID STATE RAMAN LASERS

Moscow KVANTOVAYA ELEKTRONIKA in Russian Vol 4 No 3, Mar 77 pp 513-516 manuscript received 9 Mar 76

SUKHAREVA, L. K., KHAZOV, L. D.

[Abstract] A study was made of a calcite Raman laser with a low emission threshold. Pumping was performed by short laser pulses (20-30 ns) produced by a GLS-2 glass laser. It is shown that when a number of conditions which follow from the theory of stimulated Raman scattering are met, an efficient solid state Raman laser can be created. The experimental calcite laser yields an excitation radiation energy conversion factor in the first three Stokes components of 37%. The total power of the three components is 13.5 MW, the beam divergence angle is 11', pulse duration 20 ns. The elements of the experimental laser withstood several hundred flashes with no signs of damage. The authors thank Ya. S. Bobovich for constructive criticism. Figures 4; references 9: 8 Russian, 1 Western.

RESONANCES IN THE SPECTRAL DENSITY OF THE DISTRIBUTION OF LASER RADIATION
FREQUENCY FOR A LASER WITH NONLINEAR ABSORPTION

Moscow KVANTOVAYA ELEKTRONIKA in Russian Vol 4 No 3, Mar 77 pp 697-700 manu-
script received 14 Oct 76

BAGAYEV, S. N., BASILENKO, L. S., GOL'DORT, V. G., DMITRIYEV, A. K., SKVORTSOV,
M. N., and CHEBOTAYEV, V. P., Institute of Semiconductor Physics, Siberian
Affiliate, Academy of Sciences USSR, Novosibirsk

[Abstract] A report is presented concerning observation of resonances in the radiation spectrum of a gas laser with nonlinear absorption and their use for frequency stabilization. The resonance of a radiation spectrum can be recorded by the usual methods of studying the spectral composition of laser radiation by means of a reference laser, the line width of which is less than the width of resonance of the spectrum. This method can be modified by measuring the deterministic portion of the perturbation of resonator frequency and maintaining a constant value of perturbation of oscillation frequency, slowly scanning the frequency of emission near the center of the absorption line. This method was used in the experiments here performed, utilizing an He-Ne laser with a methane absorber. The properties of the resonant spectrum allow it to be used successfully for superhigh resolution spectroscopy in low pressure gases in lasers with radiation spectral width greater than the homogeneous width of the absorption line. The author thanks Ye. V. Baklanov and Ye. A. Titov for useful discussions. Figures 3; reference 1 (Russian).

THE INTEGRAL INTENSITY OF A THREE-MODE LASER IN SELF-MODE LOCKED OPERATION

Moscow KVANTOVAYA ELEKTRONIKA in Russian Vol 4 No 3, Mar 77 pp 684-686 manu-
script received 18 Aug 76

ZAYTSEV, YU. I., and KHANDOKHIN, P. A., Scientific Research Institute for
Radiophysics, Gor'kiy

[Abstract] The purpose of this report is to turn the reader's attention to the fact that in self-mode locking of a three-mode laser, the nonlinear interaction of its modes may lead to an effect similar to the contrasting and comparatively narrow rises and drops observed upon retuning of mode frequencies in the envelope of intermode oscillations in the intensity of the full radiation. Calculations show that retuning of mode frequencies near their balanced position relative to the center of the transition line may cause a spectrally narrow low contrast peak in the integral intensity of radiation which can also be used for purposes of frequency stabilization. This peak is similar in parameters to the power peak in a laser at $\lambda = 0.63 \mu\text{m}$ with an iodine absorbing cell, which has been successfully used in automatic frequency stabilization

systems. The authors thank O. B. Shchuko for comments in comparing computer programs. Figures 2; references 7: 6 Russian, 1 Western.

USSR

UDC 535.339.04+539.1

RADIATION TRANSITIONS OF NUCLEI IN THE FIELD OF RADIATION OF A LASER

Moscow KVANTOVAYA ELEKTRONIKA in Russian Vol 4 No 3, Mar 77 pp 676-678
manuscript received 23 Jul 76

RIVLIN, L. A., All-Union Scientific Research Institute for Optical and Physical Measurements, Moscow

[Abstract] A study is made of the possibility of external electromagnetic stimulation of gamma radiation, in which the emission (or absorption) of one of the photons of a many-quantum event is caused by a secondary stimulating field of high intensity (in particular, the light beam of a laser), while the remaining photons are emitted spontaneously. Such an experiment can be conducted using nuclei in which the single-photon radiation transition is fully excluded by selection rules, a two-photon radiation transition can compete with allowed, but improbable single-photon transitions with high multipole order or only the transition $J_1=0^+ J_2=0^-$ with the emission of two photons, or one photon and one conversion electron, or two conversion electrons. The feasibility of conducting such experiments for spontaneous-stimulated emission of gamma quanta and anti-Stokes Raman light scattering is estimated. The estimates apparently indicate the possibility of observing these effects if the spectral functions used are reliable when ν is much less than 1. The author thanks R. V. Khokhlov, D. N. Klyshko and Yu. A. Il'inskiy for discussions. References 5: 3 Russian, 2 Western.

USSR

UDC 621.373:535+535.317.1

INVESTIGATION OF COHERENCE OF THE OGM-20 PULSED LASER FOR USE IN HOLOGRAPHIC INTERFEROMETRY OF PHASE OBJECTS

Leningrad OPTIKA I SPEKTROSKOPIYA in Russian Vol 42 No 2, Feb 77 pp 327-330
manuscript received 31 Jan 76

ZEYLIKOVICH, I. S., and MARKELOVA, I. V.

[Abstract] An analysis is made of the coherence requirements of lasers for different types of holographic interferometers. Since control of spatial coherence is important for using pulsed lasers in holographic interferometers,

the authors studied the influence that the temperature of cooling of the ruby rod and the pumping energy have on the spatial and temporal coherence of the OGM-20 laser. The degree of spatial coherence of the laser was determined by a previously described technique in which the hologram of a diffusely scattering screen is recorded. In reconstruction of the hologram by a narrow cw laser beam, the brightness of the reconstructed image is "modulated" by the square of the degree of spatial coherence of the laser that was used in recording the image. By sequential illumination of the hologram at two points and measurement of the intensities at the corresponding points of the reconstructed image, the degree of spatial coherence between these points can be calculated along with the original ratio of intensities of the pulsed laser emission at these points. It is shown that the spatial and temporal coherence of the OGM-20 laser depends on the amount by which the pumping energy exceeds the threshold level. This effect can be used for coherence control. The authors thank A. F. Belozerov for interest in the work and useful comments. References 7: 5 Russian, 2 Western.

USSR

UDC 533.9+621.373:535

SOME PARTICULARS OF DIAGNOSIS OF A PLASMA LOCATED INSIDE A GAS LASER CAVITY

Leningrad OPTIKA I SPEKTROSKOPIYA in Russian Vol 42 No 3, Mar 77 pp 431-438
manuscript received 11 Jul 75

MEL'NIKOV, L. A., and TUCHIN, V. V.

[Russian abstract provided by the source]

[Text] The authors consider a method of plasma spectroscopy using a gas laser. The technique is based on measuring the deviation of emission frequency that accompanies modulation of the index of refraction of a plasma located in a laser cavity. It is shown that it is possible to measure the concentration of different plasma components (electrons and atoms in metastable states) without probing the plasma with laser emission on two different wavelengths, and that the time for reaching steady-state concentration can be determined at the same time. The authors consider some particulars of probing a plasma with multimode laser emission. References 18: 15 Russian, 3 Western.

USSR

UDC 621.378.3

A COPPER VAPOR LASER WITH PULSED VAPORIZATION

Tomsk IZVESTIYA VUZOV, FIZIKA in Russian No 2(177), 1977 pp 135-136 manuscript received 21 Jun 76, after final revision 26 Jul 76

FEDOROV, A. I., SERGEYENKO, V. P., TARASENKO, V. F., and SEDOY, V. S., Institute of Optics of the Atmosphere, Siberian Department of the Academy of Sciences USSR

[Abstract] The paper gives the results of a study of stimulated emission in copper vapor produced by electric explosion of copper wires. A thin conductor fastened to steel needles on massive leads was held on the axis of the optical cavity between electrodes and exploded in vacuum by application of a high voltage across the leads. Pumping was by a transverse discharge. The energy expended in exploding the wire was 200 J, and efficiency was 0.4% at 4kW and 0.14% at 20 kW. Emission was observed on 510.6 and 578.2 nm. The authors thank Yu. I. Bychkov and Yu. A. Kotov for formulating the problem and discussing the results. Figures 3; references 5: 3 Russian, 2 Western.

USSR

NUCLEAR MASER EFFECT IN n-InSb

Leningrad FIZIKA TVERDOGO TELA in Russian Vol 19 No 4, Apr 77 pp 973-977 manuscript received 14 Jul 76

KONDRAT'YEV, M. V., KORCHEMKIN, M. A., and KHABIBULLIN, B. M., Kazan' Physico-Technical Institute, Academy of Sciences USSR

[Abstract] An investigation was made of the time dependence of intensity and phase of the derivative dk''/dH of the signal of absorption on In^{115} nuclei in single crystal InAs. An n-InAs specimen ($n = 10^{17} \text{ cm}^{-3}$, $\mu = 10^4 \text{ cm}^2/\text{V}\cdot\text{s}$ at 77 K) measuring $0.5 \times 0.4 \times 1.2 \text{ cm}$ was placed in the coil of the autodyne pickup of a broad-line NMR spectrometer at 4.2 K. The frequency of the autodyne pickup of NMR signals was fixed at 10.954 MHz, and line width was held constant at 477.5 A/m. The variable parameters were the period of scanning of the magnetic field and the rf voltage level across the tank of the pickup. It was found that in a nuclear spin system with $I > 1/2$ in the presence of considerable broadening of levels $|m| > 1/2$ both polarization and inversion of the central transition $1/2 \leftrightarrow -1/2$ may occur. Figures 4; references 3 (Russian).

ON INERT GASES AS A COMPONENT OF A REACTOR-LASER MEDIUM

Moscow DOKLADY AKADEMII NAUK SSSR in Russian Vol 233 No 6, 21 Apr 77 pp 1083-1085 manuscript received 15 Jun 76

GUDZNEKO, L. I., and LAKOBA, I. S., Physics Institute imeni P. N. Lebedev, Academy of Sciences USSR, Moscow

[Abstract] The authors consider the problem of selecting the active medium for a high-power reactor-laser. Analysis shows that xenon monofluoride is the only medium that meets requirements of chemical stability, short laser relaxation times and high energy density without disrupting inversion by overheating. As the essential characteristics of XeF as an active medium for a reactor-laser are not yet known, analysis of such a laser must await their experimental determination. Rough calculations show that the chief difficulty in realization of a reactor-laser based on a transition of the type $\text{XeF}(2) \rightarrow \text{XeF}(1)$ is the intense purging of the $\text{XeF}(2)$ level by UF_6 molecules. Therefore more research is needed on the feasibility of stimulated amplification on other transitions of mixtures of inert gases with halides, and also on transitions of vibrationally excited molecules of UF_6 and UF_5 . An examination should also be made of conditions of amplification on vibrational-rotational transitions of the ground electron term of stable fluoride molecules such as HF, where the population of the upper working level is determined by processes like

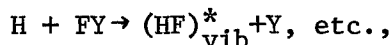
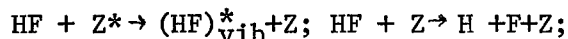

where Z^* is $(\text{RX})^*$, R^* ; Y is F, UF, or a third free particle. Reactor-laser arrangements of this kind could be steady-state. References 12: 6 Russian, 6 Western.

RATE CONSTANTS OF MULTISTAGE ELECTRON COLLISION STIMULATION OF VIBRATIONAL LEVELS IN CARBON MONOXIDE

Leningrad ZHURNAL TEKHNIЧЕСКОY FIZIKI in Russian Vol 47 No 2, Feb 77 pp 350-353 manuscript received 12 Jan 76, after final revision 21 May 76

PIVOVAR, V. A., and LEONOV, S. N.

[Abstract] Rate constants are calculated for excitation of vibrational level j from all lower-lying levels i $X^1\Sigma^+$ of the state of CO, $k_{ij}(\bar{v}_e) = \langle \sigma_{ij} v \rangle$, $i < j = 1, 2, \dots, 8$, assuming maxwellian electron energy distribution. The results agree within a factor of 2-3 with calculations of the rate constants with the exact electron distribution function in pure CO. The calculations

were done for average electron energies between 0.5 and 4.5 eV. The curves for k_{ij} with fixed j show a shift in the maximum toward lower energies with increasing i , in other words with a reduction in the transferred collisional energy as j is excited from i . The calculated rate constants for multistage excitation differ by no more than an order of magnitude from those for direct excitation at average energies between 0.5 and 1.5 eV, which shows that it is important to take them into consideration in the kinetics of excitation of vibrational levels of carbon monoxide. Figures 7; references 10: 2 Russian, 8 Western.

USSR

UDC 621.378.325

INFLUENCE THAT THE COMPOSITION OF CO₂-N₂-He(H₂) LASER MIXTURES HAS ON THE EXCITATION EFFICIENCY IN A SEMI-SELF-MAINTAINED DISCHARGED

Leningrad ZHURNAL TEKHNIЧЕСКОY FIZIKI in Russian Vol 47 No 2, Feb 77 pp 358-361 manuscript received 24 Feb 76

POPONIN, V. P., and SHOLOKHOV, YU. I., Scientific Research Institute of Electrophysical Apparatus imeni D. V. Yefremov, Leningrad

[Abstract] The paper gives the results of an investigation of the partial contribution of discharge power to vibrational modes CO₂(ν_3) + N₂(ν), as well as the excitation rate constants w_j (where $j = \nu_1, \nu_2, \nu_3$, N₂ correspond to bound symmetric and deformational, antisymmetric modes of CO₂ and the vibrational mode of N₂) as a function of the composition of mixtures of CO₂-N₂-He and CO₂-N₂-H₂ at optimum ratios of electric field strength to the concentration of neutral particles. Conditions are found under which the optimum rate constants for excitation of working laser levels are weakly dependent on the composition of the mixture. The authors thank L. V. Dubovoy for continued interest in the work, and V. M. Kozhevnikov for assistance with the computer calculations. Figures 5; tables 2; references 6: 3 Russian, 3 Western.

USSR

UDC 621.378.33

CONCERNING THE LIMIT OF APPLICABILITY OF THE VIBRATIONAL TEMPERATURE APPROXIMATION FOR NITROGEN IN SHORT-PULSE CO₂-N₂-He LASERS

Leningrad ZHURNAL TEKHNICHESKOY FIZIKI in Russian Vol 47 No 2, Feb 77 pp 346-349 manuscript received 14 Apr 76

PIVOVAR, V. A.

[Russian abstract provided by the source]

[Text] The limit of applicability of the vibrational temperature approximation for nitrogen is found on the basis of a model developed for kinetics that gives a detailed description of processes of pumping and relaxation under conditions of volumetric discharge at electron concentrations of 10^{12} - 10^{13} cm⁻³ and pulse times of 10^{-6} s or less in the active medium of a CO₂-N₂-He laser at atmospheric pressure. The existence of such a limit is dictated by the nonboltzmannian population of the first eight levels $1_s^+N_2$ during the period preceding the steady state in virtue of energy-selective g pumping on these levels under the given conditions. It is shown that such a limit can be parametrized by the quantity $\alpha = n_e/n_{N_2}$ with respect to the specific conditions of volumetric discharge. It is shown that multistage fluxes in the group of eight excited electron levels of nitrogen play an important part in the exact description of pumping processes. Figures 2; references 12: 5 Russian, 7 Western.

USSR

UDC 621.378.325

CONCERNING THE INFLUENCE OF HYDROGEN HALIDES ON THE KINETICS OF PHYSICAL PROCESSES IN A GAS DYNAMIC CO₂ LASER

Leningrad ZHURNAL TEKHNICHESKOY FIZIKI in Russian Vol 47 No 2, Feb 77 pp 331-343 manuscript received 17 Jul 75

BIRYUKOV, A. S., KULAGIN, YU. A., and SHELEPIN, L. A., Physics Institute imeni P. N. Lebedev, Academy of Sciences USSR, Moscow

[Abstract] The paper gives a theoretical analysis of the influence that hydrogen halides HCl, DCl, HF and DF have on the kinetics of physical processes and vibrational inversion in a CO₂-N₂ mixture expanding through a supersonic nozzle. The total vibrational inversion is calculated under different conditions for different contents of the components in the mixture. It is shown that in certain amounts, hydrogen halides are at least as effective as optimum additions of water vapor. An important factor from a practical standpoint for transfer chemical laser applications is that the magnitudes of inversion

are not critical to the percent content of hydrogen halides, which can vary over a range of 10-30%. An admixture of water vapor in amounts of no more than 1-3% can be tolerated in the mixture along with the hydrogen halide additive. Figures 6; tables 4; references 67: 13 Russian, 54 Western.

Magnetohydrodynamics

USSR

UDC 533.9.533.95

INVESTIGATION OF A COAXIAL MHD GENERATOR OF EXPLOSIVE TYPE

Novosibirsk FIZIKA GORENIYA I VZRYVA in Russian Vol 13 No 1, Jan/Feb 77 pp 130-132 manuscript received 16 Aug 76

BURENIN, YU. A., and SHVETSOV, G. A., Institute of Hydrodynamics, Siberian Department, Academy of Sciences USSR, Novosibirsk

[Abstract] The authors use a simple electrical engineering model to analyze the energy characteristics of an explosive MHD generator with self-excitation in which flow compression is achieved either by a converging conductive cylindrical shell or by detonation of a central conductor that acts as the return of the compression system. The generator is made up of two coaxial tubular conductors that are shorted at one end through a resistive-inductive load, and are connected at the other end to the source of initial energy. The source produces a given current in the generator circuit and is then shorted. Three modes of operation are distinguished: 1) the external and internal conductors are stationary and act as electrodes along which a conductive "piston" moves. The "piston" may be either an ionized gas flow generated in a shock tube, or a flow of detonation products; 2) the moving "piston" is the outer conductor; 3) the moving "piston" is the inner conductor. The equations that describe operation of the generator for the latter two cases are solved and compared with the solution for the first ("linear") case. The authors thank V. M. Titov for discussing the results. Figures 4; references 4: 3 Russian, 1 Western.

USSR

UDC 533.922

THE ION-BEAM PLASMA AND PROPAGATION OF INTENSE COMPENSATED ION BEAMS

Moscow USPEKHI FIZICHESKIKH NAUK in Russian Vol 121 No 2, Feb 77 pp 259-284

GABOVICH, M. D., Institute of Physics, Academy of Sciences UkrSSR, Kiev

[Russian abstract provided by the source]

[Text] A discussion of the results of research on the properties of plasma that is produced with neutralization of the space charge of an intense ion beam. The author examines the process of ion beam compensation by charges formed as a result of gas ionization by this beam, or by charges introduced from the outside. Particular attention is given to collective phenomena in an ion-beam plasma, in particular to nonlinear effects that limit the amplitude of stimulated oscillations. It is shown that the propagation of compensated ion beams is appreciably influenced not only by dynamic decompensation, but also by Coulomb collisions of ions with electrons, and by collective oscillations. In solving the problem of obtaining "superdense" compensated beams, all these processes must be considered. Figures 18; references 116: 81 Russian, 1 Romanian, 34 Western.

USSR

UDC 538.561

THE NATURE OF A SIGNAL ISOLATED FROM AN INTEGRAL ELECTROMAGNETIC PULSE

Novosibirsk ZHURNAL PRIKLADNOY MEKHANIKI I TEKHNICHESKOY FIZIKI in Russian No 1(101), Jan/Feb 77 pp 61-68 manuscript received 17 Mar 76

IVANOV, V. V., MEDVEDEV, YU. A., STEPANOV, B. M., and FEDOROVICH, G. V., Moscow

[Russian abstract provided by the source]

[Text] A technique is suggested for separating an experimentally recorded electromagnetic signal into two signals simultaneously emitted by independent sources. The method is checked out on a signal emitted when a gamma-quantum pulse is discharged into the atmosphere and is recorded together with an electromagnetic signal of another kind. The authors investigate the hypothesis as to the nature of the additional signal that is based on analyzing the effects of perturbation of the magnetic field "frozen" inside a thermal wave as hydrodynamic motions take place. It is shown that a magnetic field inside a thermal wave can be considerably amplified. It is shown that surface currents flow over the thermal wave front as it is transformed to a shock wave. Estimates demonstrate agreement between the theory and experimental data. The authors thank Yu. P. Rayzer for discussion of the problem. Figures 2; references 11: 6 Russian, 5 Western.

USSR

UDC 533.9.32

BOUNDARY CONDITIONS WHEN A NONEQUILIBRIUM PLASMA DIFFUSES IN A MAGNETIC FIELD

Novosibirsk ZHURNAL PRIKLADNOY MEKHANIKI I TEKHNICHESKOY FIZIKI in Russian No 1(101), Jan/Feb 77 pp 52-55 manuscript received 24 Feb 76

LITVINOV, I. I., Moscow

[Russian abstract provided by the source]

[Text] It is shown that various modifications of boundary conditions used in the literature for the case of diffusion of a nonequilibrium magnetized plasma toward an absorbing wall are not valid. In this connection the author finds expressions and explains the physical meaning of two basic internal parameters of a magnetized plasma: transverse mean free path and random flux of charged particles that are analogs of the corresponding quantities in a plasma without a magnetic field. These expressions are used to derive new boundary conditions that give a qualitatively correct description of the actual process. Other applications of the newly introduced parameters are discussed. References 14 (Russian).

USSR

UDC 533.95:536.24:517.946

N- AND S-MODES OF SELF-SIMILAR IMPLOSION OF A FINITE MASS OF PLASMA, AND THE PECULIARITIES OF MODES WITH A PEAK

Novosibirsk ZHURNAL PRIKLADNOY MEKHANIKI I TEKHNICHESKOY FIZIKI in Russian No 1(101), Jan/Feb 77 pp 3-23 manuscript received 25 May 76

ZMITRENKO, M. V., and KURDYUMOV, S. P., Moscow

[Russian abstract provided by the source]

[Text] The paper gives the results of numerical and analytical studies of the behavior of a plasma in modes with peaking, including modes of optimum (collisionless) compression of matter. Consideration is taken of effects of viscosity, heat conduction and conductivity. The authors explain the nature of modes with peaking both of external origin and those that arise in the medium due to nonlinear relations among processes of emanation (including dissipative) and diffusion of heat. Figures 13: references 54: 47 Russian, 7 Western.

USSR

UDC 539.234

PRODUCTION OF THIN METAL FILMS BY A PULSE PLASMA METHOD

Baku IZVESTIYA AKADEMII NAUK AZERBAYDZHANSKOY SSR, SERIYA FIZIKO-TEKHNICHESKIKH I MATEMATICHESKIKH NAUK in Russian No 4, 1976 pp 123-126 manuscript received 18 Dec 75

DAVYDOV, B. B., and EL'-BAKHRABI MOKHI EL'-DIN, Azerbaydzhan State University imeni S. M. Kirov

[Abstract] An investigation is made of application of metal films by a pulse plasma vaporizer (see the diagram).

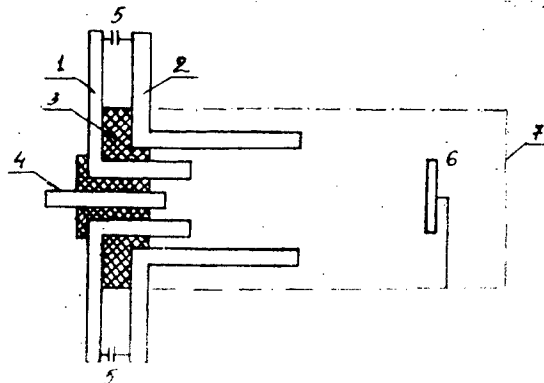

1, 2--electrodes; 3--insulators; 4--ignition electrode; 5--capacitor bank; 6--substrate; 7--vacuum chamber

The vaporizer is a coaxial system of electrodes 1, 2, 4 separated by ceramic and Teflon insulators 3. The power supply is capacitor bank 5. Discharge is initiated by a high-voltage pulse applied to electrode 4 by a special igniting device. A spark jumps between electrodes 1 and 4 and ignites the main discharge between electrodes 1 and 2. An azimuthal magnetic field interacts with the axial and radial components of the current flowing through the device, compressing the plasma and accelerating it in the longitudinal direction, depositing it on substrate 6. Experiments were done with Ga, In, Al and Cu electrodes. Rates of deposition reached 10^5 Å/s, and it should be possible to achieve rates of 10^7 - 10^8 Å/s. Thin films can be produced at relatively high pressures (10^{-2} - 10^{-3} mm Hg) from any conductive materials, including refractory ones. Dielectric and semiconductor films can also be produced with slight modification of the design. The authors thank K. I. Efendiyev and N. A. Mamedov for discussing the results of the work. Figure 1; table 1; references 5 (Russian).

USSR

UDC 537.525.1

LOW-FREQUENCY OSCILLATIONS OF PLASMA DENSITY IN THE POSITIVE COLUMN OF A GAS DISCHARGE

Leningrad ZHURNAL TEKHNICHESKOY FIZIKI in Russian Vol 47 No 2, Feb 77 pp 428-429 manuscript received 21 Oct 75, after final revision 23 Mar 76

ALANAKYAN, YU. R., All-Union Scientific Research Institute of Physicotechnical and Radiotechnical Measurements, Mendeleyevo

[Abstract] The problem of low-frequency oscillations of plasma density in a positive gas-discharge column is considered in the approximation of the simplest model of an atom with a single metastable level, assuming that the plasma is quasi-neutral and that the electric field has an appreciable influence only on coefficients that characterize the ionization and excitation of atoms. It is found that negative ions have a destabilizing effect which becomes oscillatory when the concentration of negative ions is sufficiently high. References 5: 3 Russian, 2 Western.

ON THE THEORY OF A RELATIVISTIC PLASMA EMITTER

Leningrad ZHURNAL TEKHNICHESKOY FIZIKI in Russian Vol 47 No 2, Feb 77 pp 249-254 manuscript received 8 Jul 75

BOGDANKEVICH, L. S., and RUKHADZE, A. A., Physics Institute imeni P. N. Lebedev, Academy of Sciences USSR, Moscow

[Russian abstract provided by the source]

[Text] An examination is made of a problem that is close to the actual experiment of excitation of electromagnetic waves in a plasma cylinder partly filling a metal waveguide and penetrated by a relativistic electron beam. It is assumed that a strong external longitudinal magnetic field is imposed on the system, magnetizing both the beam and the plasma. Such a field focuses the beam, and under certain conditions also ensures coherence of the emission stimulated by the beam. Conditions of stimulation of a TB_{01} wave are found in the system as well as the maximum attainable amplitude of the wave and the energy flux carried off by the emission. References 4 (Russian).

USSR

UDC 621.039.3

NEW METHODS OF ISOTOPE SEPARATION

Moscow USPEKHI FIZICHESKIKH NAUK in Russian Vol 121 No 3, Mar 77 pp 427-455

BASOV, N. G., BELENOV, E. M., ISAKOV, V. A., MARKIN, YE. P., ORAYEVSKIY, A. N., and ROMANENKO, V. I., Physics Institute imeni P. N. Lebedev, Academy of Sciences USSR

[Russian abstract provided by the source]

[Text] A survey of new methods relating to two fundamentally different approaches to the problem of isotope separation. The first approach is based on selectivity of action on certain isotopic modifications of atoms and molecules. These are primarily techniques of laser separation of isotopes: separation by the pressure of light in two-stage schemes of excitation of atoms and molecules, etc. The survey gives particular emphasis to the second approach to the problem of isotope separation that is based on selective action on conditions under which processes take place that lead to a difference in the properties of isotopic molecules. It is shown that isotopes can be effectively separated in processes with the participation of resonantly (vibrationally) excited molecules. In this case the isotopic selectivity of the processes is due to specific exchange of vibrational energy between the isotopic molecules. Figures 13; references 108: 53 Russian, 1 Polish, 54 Western.

USSR

UDC 621.378.33

RESONANCE (10.6 μm) ABSORPTION OF CO_2 BEHIND A SHOCK WAVE FRONT

Novosibirsk ZHURNAL PRIKLADNOY MEKHANIKI I TEKHNICHESKOY FIZIKI in Russian No 1(101), Jan/Feb 77 pp 42-46 manuscript received 11 May 76

SOLOUKHIN, R. I., and FOMIN, N. A., Novosibirsk

[Russian abstract provided by the source]

[Text] Systematic measurements are made of the coefficient of absorption of resonance emission on 10.6 μm in CO_2 and in a $\text{CO}_2 + \text{N}_2$ mixture over a wide range of variations in gas temperature and pressure ($0.2 \leq p \leq 12$ atm; $500 \leq T \leq 2100$ K). Dependences $\alpha(T, p)$ at pressures $p \leq 6$ atm are fairly accurately described by the simplest theory with consideration of the contribution of transitions of "bound" states, and also on the assumption of a temperature dependence of the broadening cross section in the form $\sigma_c \sim T^{-1/2}$. The authors thank Yu. A. Yakobi and Yu. Ya. Kuzyakov for constructive criticism and discussions, and G. A. Zavarzin for assistance with the experiment. Figures 5; references 17: 5 Russian, 12 Western.

USSR

UDC 533.6.011.72

VIBRATIONAL RELAXATION OF POLYATOMIC MOLECULES IN THE FIELD OF MONOCHROMATIC RADIATION BEHIND A SHOCK WAVE FRONT

Novosibirsk ZHURNAL PRIKLADNOY MEKHANIKI I TEKHNICHESKOY FIZIKI in Russian No 1(101), Jan/Feb 77 pp 30-34 manuscript received 17 Mar 76

KUZNETSOV, V. M., Moscow

[Russian abstract provided by the source]

[Text] The author investigates an analytical model of flow of a polyatomic gas behind a shock wave in the presence of vibrational relaxation and external monochromatic radiation that is absorbed on certain vibrational levels. A study is made of the effect of heating of internal degrees of freedom by radiation, as a result of which the vibrational temperature in the relaxation zone may appreciably exceed the translational-rotational temperature. The author thanks M. M. Kuznetsov for discussing the results. Figure 1; references 11: 8 Russian, 3 Western.

USSR

UDC 533.6.011.72

VIBRATIONAL RELAXATION OF CO₂ IN A SHOCK WAVE IN MIXTURES WITH F₂

Leningrad ZHURNAL TEKHNICHESKOY FIZIKI in Russian Vol 47 No 2, Feb 77 pp 344-345 manuscript received 18 Sep 75

VASIL'YEV, G. K., MAKAROV, YE. F., and PANIN, V. G., Institute of Chemical Physics, Academy of Sciences USSR, Chernogolovka

[Russian abstract provided by the source]

[Text] Vibrational relaxation of CO₂ in mixtures with F₂ and Ar is studied by the method of registration of emission in the 4.3 μm region behind a shock wave front at temperatures of 750-1650 K. The acceleration of vibrational relaxation of CO₂ when F₂ is added is interpreted in terms of the influence of the exchange of vibrational energy between the deformation mode of CO₂ and the F₂ molecule, which has a shorter natural relaxation time. Figure 1; references 18: 17 Russian, 1 Western.

INVESTIGATION OF ELECTRON BEAM INJECTION INTO A BETATRON

Leningrad ZHURNAL TEKHNIЧЕСКОY FIZIKI in Russian Vol 47 No 2, Feb 77 pp 370-372 manuscript received 4 Dec 75

PAVLOVSKIY, A. I., KULESHOV, G. D., GERASIMOV, A. I., KLEMENT'YEV, A. P., KUZNETSOV, V. O., TANANAKIN, V. A., and TARASOV, A. D.

[Abstract] Processes of betatron electron injection were investigated in the 2 MeV range. Injectors of the Kerst type were used ($E = 10\text{--}200$ keV) in the acceleration region, as well as external units--an induction linac (E up to 1.1 MeV) and injection devices with transformer generator (E up to 2 MeV) with beam input devices--an electrostatic inflector or shielding channel. The research was done in geometrically similar betatrons with equilibrium orbit radii of 3.9, 7.8, 11.7 and 23.4 cm in which the azimuthal nonhomogeneities (of the order of 0.5%) are independent of the field amplitude, and phase nonhomogeneities are practically nonexistent. The injection pulse duration varied from 10^{-8} to 10^{-6} s, the derivative of the magnetic field on the orbit ranged from a negative value of $6.5 \cdot 10^5$ oe/s [$5.2 \cdot 10^7$ A·m $^{-1}$ ·s $^{-1}$] to $+6 \cdot 10^7$ oe/s [$4.8 \cdot 10^8$ A·m $^{-1}$ ·s $^{-1}$]. The injection current amplitude ranged from a fraction of an ampere to 100 A depending on the injection energy, and the divergence of the beam of injected particles varied from 0 to 5°. Most measurements showed a relation between the pulse intensity of bremsstrahlung and the injection parameters. It was found that the maximum current of the accelerated electrons circulating in the betatron chamber is independent of accelerator size for a given initial energy. The emission intensity and the trapped charge are proportional to the equilibrium orbit. Attempts to increase the circulating electron current by multiple injection, optimization of the pulse shape and varying the time derivative of the driving field were not successful. Figures 3; references 7 (Russian).

USSR

A HIGH SPEED INFRARED SPECTROPYROMETER FOR THE STUDY OF FLAMES IN CONDENSED SYSTEMS

Novosibirsk FIZIKA GORENIYA I VZRYVA in Russian Vol 12 No 6, Nov/Dec 76
pp 890-896 manuscript received 16 Jun 75

BAKHIR, L. P., and LEVASHENKO, G. I., Institute of Physics, BSSR, Minsk

[Abstract] This work describes a complex of apparatus designed to study processes of combustion of condensed systems under high pressures using infrared radiation. The main portion of the apparatus is an infrared high speed spectrometer which can record the spectral brightness and transparency of a flame as they vary with time in order to determine the longitudinal temperature profiles by the method of light emission and absorption, as well as the concentrations of individual radiating components through the height of the flame. It also measures the absolute radiation capacity of the flame, in combination with rapid recording of spectra over a broad range of wavelengths in various scanning modes. According to an experimental test of the instrument with an aperture of 0.02, slit size 0.2x4 mm, a signal to noise ratio of 10 and 3 (as pyrometer and spectrometer, respectively) can be achieved with flame brightness temperatures of 1000, 1200 and 2200 K at wavelengths of 2, 4 and 6 μm respectively. Increasing the aperture to 0.05 extends the lower limit of measurement of temperatures to 750, 900 and 1250 K for the same wavelengths. Complete filling of the monochromator lens with an aperture of $\sin u=0.11$ causes the signal to noise ratio to increase by four times. References 4: 3 Russian, 1 Western.

USSR

UDC 621.378.5

DEVELOPMENT OF DEFECTS IN THE ACTIVE REGION OF HETEROLASERS

Minsk ZHURNAL PRIKLADNOY SPEKTROSKOPII in Russian Vol 26 No 2, Feb 77 pp 243-247 manuscript received 6 Apr 76

GRIBKOVSKIY, V. P., KONONENKO, V. K., PAK, G. T., RYABTSEV, G. I., SAMOYLYUKOVICH, V. A., and YASHUMOV, I. V.

[Abstract] Structural defects arise and develop in degradation of heterolasers. These defects are complex in nature and the reasons for their formation may be various factors. In this paper the authors study localization and stages of development of defects that arise close the side faces and on the boundary between substrate and epitaxial layers, and investigate the influence of defects on luminescence spectra in the process of degradation of heterolasers. The experiments were done at 300 K on laser diodes with double heterostructure in the system $\text{GaAs-Al}_x\text{Ga}_{1-x}\text{As}$ in which the active

region was either undoped or doped with silicon. The defects arising in the heterostructure were photographed in transmitted light by an infrared microscope. It was found that the defects cause changes in the luminescence spectra from the reflecting and side faces before there is any noticeable reduction of emission power or increase in the threshold of stimulated emission. Therefore luminescence measurements might be a very sensitive method of studying degradation in semiconductor lasers. Figures 4; references 7 (Western).

USSR

UDC 533.338.3

SOURCE FUNCTION IN A FLOW OF COMBUSTION PRODUCTS WITH ALKALINE ADDITIVE

Minsk ZHURNAL PRIKLADNOY SPEKTROSKOPII in Russian Vol 26 No 2, Feb 77 pp 235-242 manuscript received 19 Dec 75

VASIL'YEVA, I. A.

[Russian abstract provided by the source]

[Text] The author considers the source function in optical coordinates that characterizes the emission of sodium atoms in local-equilibrium flows of combustion products with homogeneous central part. Two cases are studied: a Mecker torch with shielded jet, and a turbulent flow in a channel. It is shown that in the first case the source functions fall off linearly in the shielded jet. This step source function is used to express the profile of the emission line in elementary functions that depend on the relative optical density of a homogeneous jet ξ_{lim} and the total temperature drop in the shielded jet $T(z)/T(z/2)$. Simple expressions are found for the Bartels non-homogeneity parameters in terms of these same two parameters.

In the case of a turbulent flow, the source function in the boundary layer is more complicated, but when profiles of the emission line are used in the vicinity of their maxima or even further from the line center, the described step source function and the expression of the profile in elementary functions can be used. In this case, ξ_{lim} and $T(z)/T(z/2)$ are determined from the known flow characteristics, using simple relations. The author thanks A. P. Nefedov for calculations of the distributions of the concentrations of atoms in the boundary layer of the turbulent flow. Figures 5; references 12: 7 Russian, 5 Western.

USSR

UDC 535.317.1

USING THE EMISSION OF ELECTRON STORAGE RINGS IN X-RAY HOLOGRAPHY OF MICROSCOPIC OBJECTS

Leningrad OPTIKA I SPEKTROSKOPIYA in Russian Vol 42 No 2, Feb 77 pp 338-344
manuscript received 18 Dec 75

KONDRZTENKO, A. M., and SKRINSKIY, A. N.

[Abstract] An investigation is made of the possibilities for using synchrotron radiation in x-ray holography. The coherence properties of synchrotron radiation are described and compared with emission from x-ray tubes. It is shown that the part of the synchrotron radiation of the VEPP-3 storage ring in Novosibirsk that can be used for holography has a power that exceeds that of coherent emission of x-ray tubes by three orders of magnitude. In addition to high-power coherent emission, synchrotron radiation can be used for holographic x-ray study of microscopic objects in any "color." These advantages are retained into the far ultraviolet where modern lasers are no longer usable. The lensless Fourier transform hologram method proposed by G. W. Stroke is preferable for x-ray holography of microscopic objects. This system is to be analyzed in a subsequent paper. The authors thank Ya. S. Derbenyov, E. P. Kruglyakov, G. N. Kulipanov and V. F. Pindyurin for useful discussions and comments. Figure 1; references 9: 4 Russian, 5 Western.

USSR

UDC 537.528

EMISSION AND EQUILIBRIUM COMPOSITION OF A PULSED DIAPHRAGM DISCHARGE PLASMA IN ELECTROLYTES

Leningrad ZHURNAL TEKHNIЧЕСКОY FIZIKI in Russian Vol 47 No 2, Feb 77 pp 255-262
manuscript received 1 Oct 75

DROBYSHEVSKIY, E. M., ZHUKOV, B. G., REZNIKOV, B. I., and ROZOV, S. I., Physico-Technical Institute imeni A. F. Ioffe, Academy of Sciences USSR, Leningrad

[Russian abstract provided by the source]

[Text] An examination is made of the luminescence spectra and parameters of the plasma of a plasmoid that arises with pulsed diaphragm discharge in electrolytes (solutions of sodium and potassium salts in water). The luminescence spectrum of the plasmoid is continuous. The brightness temperature of the plasma is about 5000-9000 K. Calculations are done on the equilibrium composition of the $H_2O + NaCl$ system at $T = (4-12) \cdot 10^3 K$ and $p = 200-4000$ atmospheres. When T is less than 7000 K, the electron concentration in such a plasma is lower than the concentration of negative chlorine ions.

From the computational data and the measured p and T the authors determine the concentration of charged particles, reduction of ionization potential and

parameters of departure from ideality γ of a pulsed diaphragm discharge plasma ($\gamma = 0.4-1$). It is noted that the pulsed diaphragm discharge plasma has an advantage over high-power linear discharges in fluids in that a dense plasma with large departure from ideality can be produced. The authors thank Yu. A. Dunayev for his support. Figures 4; tables 2; references 16: 14 Russian, 2 Western.

USSR

UDC 539.186.2

CONCERNING THE INFLUENCE THAT RADIATION CAPTURE HAS ON THE SPATIAL DISTRIBUTION OF LINE INTENSITY IN AN ELECTRON BEAM

Leningrad OPTIKA I SPEKTROSKOPIYA in Russian Vol 42 No 2, Feb 77 pp 248-251
manuscript received 18 Dec 75

BEZUGLOV, N. N., GOLUBOVSKIY, YU. B., GORSHKOV, V. N., and OSHEROVICH, A. L.

[Russian abstract provided by the source]

[Text] Radial distributions of the brightness of lines He I 5016, 6678, 7281 and 3888 Å and of line Ar I 7504 Å are measured in an electron gun excitation chamber at pressures of $10^{-4}-5 \cdot 10^{-1}$ mm Hg. Because of the effect of radiation capture, the radial distribution of brightness of line 5016 Å is broadened relative to the other lines. The experimental results are quantitatively analyzed on a computer on the basis of radiation capture theory. The theoretical calculation gave a total quenching cross section of $3.5 \cdot 10^{-14}$ cm² for level 3^1P_1 of He I. The authors thank L. I. Lyagushchenko for constructive comments. Figures 3; references 8: 2 Russian, 6 Western.

USSR

UDC 62-50

ASYMPTOTIC SOLUTIONS OF SOME PROBLEMS IN OPTIMUM PROBABILITY CONTROL

Moscow PRIKLADNAYA MATEMATIKA I MEKHANIKA in Russian Vol 41 No 1, Jan/Feb 77
pp 13-23 manuscript received 24 Feb 76

BRATUS', A. P., Moscow

[Russian abstract provided by the source]

[Text] The author considers the problem of optimum control of a stochastic dynamic system for the purpose of maximizing the probability of arrival at a fixed set in a finite time. It is assumed that the set is a sphere of small radius. An irregular asymptotic expansion is constructed with respect to powers of the radius of the sphere as a small parameter. Each term of this expansion is in explicit analytical form. Approximate synthesis of the optimum control is found. Estimates of the error of the proposed method are proved and examples are given. References 9: 8 Russian, 1 Western.

USSR

UDC 539.3

ON A PLANE PROBLEM OF ELASTICITY THEORY FOR A HALF-STRIP

Moscow PRIKLADNAYA MATEMATIKA I MEKHANIKA in Russian Vol 41 No 1, Jan/Feb 77
pp 124-133 manuscript received 20 May 76

GUSEYN-ZADE, M. I., Moscow

[Abstract] The author considers the plane problem of elasticity theory for the half-strip $0 \leq x < \infty$, $-1 \leq y \leq 1$, assuming that body forces are acting with different boundary conditions on the edge $x = 0$, and that the stresses on the longitudinal edges are given. Symmetric and antisymmetric deformations of the strip are examined separately. References 7 (Russian).

USSR

UDC 534.222.2+623.565.5

CONCERNING THE MECHANICAL ACTION OF A BLAST CLOSE TO THE SURFACE OF THE GROUND

Novosibirsk FIZIKA GORENIYA I VZRYVA in Russian Vol 13 No 1, Jan/Feb 77 pp 110-114 manuscript received 10 Oct 75

IVANOV, B. A., Institute of Physics of the Earth, Academy of Sciences USSR, Moscow

[Abstract] The author studies the relation between the parameters of mechanical action of an explosion when the charge is placed slightly below the surface of the ground. Experiments are done to determine the vertical component of the momentum transmitted to the half-space in the blast, the velocity of dispersal of particles of earth torn from the ground, the residual displacements in the epicentral zone under the blast point and the dimensions of the resultant crater. The techniques used for measuring these quantities are explained. The ratio of charge depth to radius was varied from 0 to 2.5. It is found that to some extent the measured parameters of mechanical action remain similar over the entire range of blasting depths. The author thanks V. N. Kostyuchenko for useful discussions and A. P. Sukhotin for permission to use equipment for optical observations and for considerable help with the experiments. Figures 4; references 7: 6 Russian, 1 Western.

USSR

UDC 535.21

THE INFLUENCE OF COLLISIONS ON FOUR-PHOTON PARAMETRIC PROCESSES IN GASES

Moscow KVANTOVAYA ELEKTRONIKA in Russian Vol 4 No 3, Mar 77 pp 648-650
manuscript received 1 Jun 76

SAPRYKIN, E. G., and SMIRNOV, G. I., Institute of Automation and Electrometry,
Siberian Affiliate, Academy of Sciences USSR, Novosibirsk

[Abstract] A study is made of the problem of the influence of isotropic depolarizing collisions corresponding to independent decay of multipole moments of the electron shell on resonant four-photon parametric processes, and the possibility of using these processes for the measurement of relaxation constants of these moments is analyzed. It is shown that the parametric oscillation does not occur if the alignment and orientation constants are equal. The authors thank S. G. Rautian and A. K. Popov for discussion. References 9: 7 Russian, 2 Western.

USSR

UDC 535:530.182

THE MOTION INTEGRALS OF A NONLINEAR FOUR-PHOTON INTERACTION

Moscow KVANTOVAYA ELEKTRONIKA in Russian Vol 4 No 3, Mar 77 pp 700-703 manuscript received 29 Apr 76, after final revision 15 Dec 76

GRIN', YU. G., KARAMZIN, YU. N., and SUKHORUKOV, A. P., Moscow State University, Institute of Applied Mathematics, Academy of Sciences USSR

[Abstract] A study is made of a system of equations describing a four-photon interaction in a nonlinear medium in the quasioptical approximation. In contrast to the equations usually used, the \hat{L}_j operator includes second derivatives with respect to transverse coordinates, allowing effects related to diffraction spreading of beams and self- and mutual-focusing due to the second term in the right portion of the equations to be considered. Consideration of diffraction spreading is necessary, since in order to produce significant conversion factors in experiments, beams are highly focused. The self-focusing terms are also important in four-photon processes, for example in the generation of a third harmonic. The integrals found allow analysis of the behavior of the interacting fields in a nonlinear cubic medium. They can be used to estimate various characteristics of beams, to draw conclusions concerning their propagation mode, etc. They are also quite useful for checking of numerical experiments. References 9: 4 Russian, 5 Western.

ON THE STEFAN PROBLEM THAT ARISES IN THE THEORY OF POWDER COMBUSTION

Moscow PRIKLADNAYA MATEMATIKA I MEKHANIKA in Russian Vol 41 No 1, Jan/Feb 77
pp 95-101 manuscript received 16 Jan 76

SUSLOV, A. I., Moscow

[Abstract] The author considers the free boundary problem

$$\begin{aligned}
 (1) \quad & T_t = T_{xx} \text{ in region} \\
 & D \{ -\infty < x < s(t), 0 < t < A \} \\
 (2) \quad & T|_{t=0} = f(x), \quad T|_{x=s(t)} = 1, \quad T \xrightarrow{x \rightarrow \infty} 0 \\
 (3) \quad & s'(t) = -u(p(t), T_x(s(t), t)), \quad s(0) = 0
 \end{aligned}$$

This problem arises in the one-dimensional theory of powder combustion with constant surface temperature. The function $T(x,t)$ is the temperature of the powder, u is the burning rate, $s(t)$ is the coordinate of the surface of the powder at time t . The functions $T(x,t)$ and $s(t)$ are to be determined. This problem differs from the classical Stefan problem in that relation (3) between $s'(t)$ and $T_x(s(t), t)$ is nonlinear. The assigned function $p(t)$ from (3) is pressure in the gas phase ($x > s(t)$) that contains products of gasification of the powder and products of combustion. Theorems of existence and uniqueness of solutions of this problem are proved. In the case where the problem has a solution of the stationary wave type, sufficient conditions are found for stability of such a solution to perturbations of initial data. The author thanks O. A. Oleynik and V. B. Librovich for constructive criticism and interest in the work. References 8: 6 Russian, 2 Western.

USSR

UDC 536.463

DEVELOPMENT OF PERTURBATIONS ON THE SURFACE OF A FLAME PROPAGATING FROM A CENTRAL POINT SOURCE OF IGNITION IN A CLOSED VESSEL

Novosibirsk FIZIKA GORENIYA I VZRYVA in Russian Vol 13 No 1, Jan/Feb 77 pp 19-24 manuscript received 1 Dec 75

GUSSAK, L. A., ISTRATOV, A. G., LIBROVICH, V. B., and SPRINTSINA, YE. N., Institute of Chemical Physics, Academy of Sciences USSR, Moscow

[Russian abstract provided by the source]

[Text] High-speed motion picture photography by the Topler schlieren method is used to study the stability of propagation of a spherical flame in a propane-air mixture in a small-volume chamber in the concentration range from the limit of richness with an excess air ratio α from 0.47 (8.5% C₃H₈ in air) to the limit of leanness 1.34 (3% C₃H₈ in air) and at initial pressures from 1 to 5 absolute atmospheres. The pressure was recorded simultaneously. Table 1; figures 4; references 13 (Russian).

USSR

UDC 536.46

ON THE INITIAL STAGE OF GAS COMBUSTION IN A CLOSED SPACE

Novosibirsk FIZIKA GORENIYA I VZRYVA in Russian Vol 13 No 1, Jan/Feb 77 pp 24-29 manuscript received 15 Oct 75

BABKIN, V. S., and BABUSHOK, V. I., Institute of Chemical Kinetics and Combustion, Siberian Department of the Academy of Sciences USSR, Novosibirsk

[Russian abstract provided by the source]

[Text] The authors examine the problem of the initial stage of propagation of a laminar flame of a homogeneous gas mixture in a closed space of arbitrary shape. Approximate relations between the parameters of the fresh gas, combustion products and time are found and substantiated. Possible applications of the results in the area of fire and explosion prevention are discussed. Tables 2; references 13: 9 Russian, 4 Western.

THERMAL EXPLOSION OF REACTING SYSTEMS WITH PARALLEL REACTIONS

Novosibirsk FIZIKA GORENIYA I VZRYVA in Russian Vol 13 No 1, Jan/Feb 77 pp 48-55 manuscript received 27 Jan 76

ABRAMOV, V. G., VAGANOV, D. A., and SAMOYLENKO, N. G., Division of the Institute of Chemical Physics, Academy of Sciences USSR, Chernogolovka

[Russian abstract provided by the source]

[Text] Simultaneous occurrence of several parallel reactions leads to complication of the principles that govern thermal explosion as compared with a single-stage reaction. The problem is reduced to N. N. Semenov's classical case by introducing an effective activation energy. The critical condition of thermal explosion in the quasi-steady state approximation is determined. An examination is made of the time characteristics of a thermal explosion. An expression is derived for the correction due to depletion. Figures 6; references 6 (Russian).