

JPRS 72141

30 October 1978

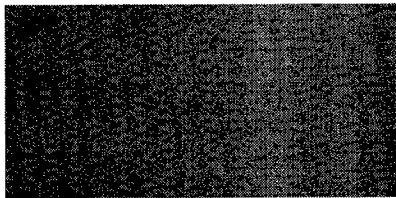

U S S R

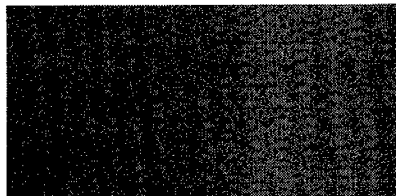
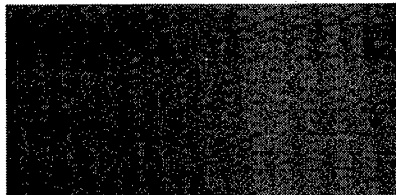

TRANSLATIONS ON USSR SCIENCE AND TECHNOLOGY
PHYSICAL SCIENCES AND TECHNOLOGY

No. 53

DISTRIBUTION STATEMENT A
Approved for Public Release
Distribution Unlimited

Reproduced From
Best Available Copy

U. S. JOINT PUBLICATIONS RESEARCH SERVICE

20000329 076



NOTE

JPRS publications contain information primarily from foreign newspapers, periodicals and books, but also from news agency transmissions and broadcasts. Materials from foreign-language sources are translated; those from English-language sources are transcribed or reprinted, with the original phrasing and other characteristics retained.

Headlines, editorial reports, and material enclosed in brackets [] are supplied by JPRS. Processing indicators such as [Text] or [Excerpt] in the first line of each item, or following the last line of a brief, indicate how the original information was processed. Where no processing indicator is given, the information was summarized or extracted.

Unfamiliar names rendered phonetically or transliterated are enclosed in parentheses. Words or names preceded by a question mark and enclosed in parentheses were not clear in the original but have been supplied as appropriate in context. Other unattribute parenthetical notes within the body of an item originate with the source. Times within items are as given by source.

The contents of this publication in no way represent the policies, views or attitudes of the U.S. Government.

PROCUREMENT OF PUBLICATIONS

JPRS publications may be ordered from the National Technical Information Service (NTIS), Springfield, Virginia 22151. In ordering, it is recommended that the JPRS number, title, date and author, if applicable, of publication be cited.

Current JPRS publications are announced in Government Reports Announcements issued semimonthly by the NTIS, and are listed in the Monthly Catalog of U.S. Government Publications issued by the Superintendent of Documents, U.S. Government Printing Office, Washington, D.C. 20402.

Indexes to this report (by keyword, author, personal names, title and series) are available through Bell & Howell, Old Mansfield Road, Wooster, Ohio, 44691.

Correspondence pertaining to matters other than procurement may be addressed to Joint Publications Research Service, 1000 North Glebe Road, Arlington, Virginia 22201.

Soviet journal articles displaying a copyright notice and included in this report are reproduced and sold by NTIS with permission of the copyright agency of the Soviet Union. Further reproduction of these copyrighted journal articles is prohibited without permission from the copyright agency of the Soviet Union.

BIBLIOGRAPHIC DATA SHEET		1. Report No. JPRS 72141	2.	3. Recipient's Accession No.
4. Title and Subtitle TRANSLATIONS ON USSR SCIENCE AND TECHNOLOGY - PHYSICAL SCIENCES AND TECHNOLOGY No. 53			5. Report Date 30 October 1978	6.
7. Author(s)			8. Performing Organization Repr. No.	
9. Performing Organization Name and Address Joint Publications Research Service 1000 North Glebe Road Arlington, Virginia 22201			10. Project/Task/Work Unit No.	
			11. Contract/Grant No.	
12. Sponsoring Organization Name and Address As above			13. Type of Report & Period Covered	
			14.	
15. Supplementary Notes				
16. Abstracts The report contains information on aeronautics; astronomy and astrophysics; atmospheric sciences; chemistry; earth sciences and oceanography; electronics and electrical engineering; energy conversion; materials; mathematical sciences; cybernetics, computers; mechanical, industrial, civil, and marine engineering; methods and equipment; missile technology; navigation, communications, detection, and countermeasures, nuclear science and technology; ordnance; physics; propulsion and fuels; space technology; and scientists and scientific organization in the physical sciences.				
17. Key Words and Document Analysis. 17a. Descriptors				
USSR		Electronics	Missile Technology	
Aeronautics		Electrical Engineering	Navigation and	
Astronomy		Energy Conversion	Communications	
Astrophysics		Materials	Detection and	
Atmospheric Sciences		Mathematics	Countermeasures	
Chemistry		Mechanical Engineering	Nuclear Science and	
Computers		Civil Engineering	Technology	
Cybernetics		Industrial Engineering	Ordnance	
Earth Sciences		Marine Engineering	Physics	
Oceanography		Methods	Propulsion and Fuels	
17b. Identifiers/Open-Ended Terms		Equipment	Space Technology	
17c. COSATI Field/Group 01,03,04,07,08,09,10,11,12,13,14,16,17,18,19,20,21,22				
18. Availability Statement Unlimited Availability Sold by NTIS Springfield, Virginia 22151			19. Security Class (This Report) UNCLASSIFIED	21. No. of Pages 73
			20. Security Class (This Page) UNCLASSIFIED	22. Price

TRANSLATIONS ON USSR SCIENCE AND TECHNOLOGY
PHYSICAL SCIENCES AND TECHNOLOGY

No. 53

CONTENTS

PAGE

CYBERNETICS, COMPUTERS AND AUTOMATION TECHNOLOGY

The Development of Measuring Information Systems (M. P. Tsapenko; PRIBORY I SISTEMY UPRAVLENIYA, Aug 78)	1
The Automated State Statistical System (L. M. Volodarskiy; EKONOMICHESKAYA GAZETA, Jun 78) ...	9
Automated System for Plan Calculations in Uzbek SSR (G. Zakirov; EKONOMIKA I ZHIZN', No 6, 1978)	14
Complete Miniaturization in Instrument Building, Computer Technology and Electronics (Yu. R. Nosov; PRIBORY I SISTEMY UPRAVLENIYA, No 8, 1978)	21
Ukrainian Gosplan Automated Plan Accounting System (M. T. Matveyev, et al.; MEKHANIZATSIYA I AVTOMATIZATSIYA UPRAVLENIYA, Jul/Aug/Sep 78)	27
Ukrainian Scientific and Technical Information System (V. P. Tron', et al.; MEKHANIZATSIYA I AVTOMATIZATSIYA UPRAVLENIYA, Jul/Aug/Sep 78)	33
MARS NTI Retrieval Software Described (G. A. Solov'yeva; MEKHANIZATSIYA I AVTOMATIZATSIYA UPRAVLENIYA, Jul/Aug/Sep 78)	39

ELECTRONICS AND ELECTRICAL ENGINEERING

Synthesis of Multichannel Radars for Measuring the Coordinates of Objects (A. P. Lukoshkin, S. S. Poddubnyy; IZVESTIYA VUZOV SSSR - RADIOELEKTRONIKA, Apr 78)	41
Methods of Engineering Realization of Read Out Devices for Plane Magnetic Domains (N. P. Vasil'yeva, O. A. Sedykh; PRIBORY I SISTEMY UPRAVLENIYA, Jul 78)	53

CONTENTS (Continued)

Page

SCIENTISTS AND SCIENTIFIC ORGANIZATIONS

Biography of Azerbaydzhan Scientist Abdullayev
(A. Prokhorov, et al.; BAKINSKIY RABOCHIY, 20 Aug 78) 66

THE DEVELOPMENT OF MEASURING INFORMATION SYSTEMS

Moscow PRIBORY I SISTEMY UPRAVLENIYA in Russian No 8, Aug 78 pp 4-6

[Article by Doctor of Technical Sciences M. P. Tsapenko]

[Text] The concept of measuring information systems (IIS) was developed in the early 60's [1-4]. As we know, it resulted from the requirements of science and the national economy for new facilities for obtaining masses of measurement, control and diagnostic information in limited periods of time and with minimum human participation. The basis of this concept was the organization of simultaneous automatic operation of measurement and computation devices in a special class of information equipment, to be called measuring information systems.

In IIS, the required information is obtained directly from the process being studied by measurement and/or monitoring, the processing of the information and its presentation in the form of a body of concrete numbers, graphs, statements and the like, reflecting the status of the process [5]. These systems not only are significantly more complex than other types of measuring equipment, but also perform more complex functions.

The term "measuring information system" is a general one; the main varieties of IIS are designated according to the functions they perform as measuring systems, automatic monitoring systems, technical diagnostic systems or specimen identification systems.

Specific realizations of these different types of IIS or their common core (which, for example, can be used with various kinds of sensors and measurement circuits) may have names which reflect the area of their utilization or characteristics of their structure. Thus, we are familiar with machines for centralized monitoring, units for checking metrological characteristics of measurement equipment and so on.

The organization of information processing in IIS commands considerable attention. Specialists in measuring information equipment producing quantitative information have always concerned themselves with the organization of simultaneous measurement and processing. Essentially, information processing takes place in all measuring instruments. A number of computational operations are carried out simultaneously with measurement operations by compensation, bridge, differential

and logometric measuring circuits, by measuring mechanisms with two or more input values (e.g. wattmeters, phasemeters and ratio meters) and by other measuring devices.

In order to perform complex types of measurement (indirect, aggregate, simultaneous), and also to make quantitative decisions during monitoring, diagnosis and sample identification, specialized computation devices, i.e. instrumental [as opposed to programming] methods of information processing, were utilized in the initial stage of development of IIS. This stage of development of information collection and processing equipment constituted the first generation of IIS.

First-generation IIS (early 60's) featured centralized cyclic collection and processing of information according to a rigid, unchanging program, using specialized computation devices; discrete semiconductor technology was used in the construction of these first-generation systems.

As digital computer technology developed, a number of measurement and computation procedures were unified in IIS: after analog-to-digital conversion, the measurements were fed to a digital computer where programmed processing operations required to obtain the results of complex measurements and tolerance and multidimensional monitoring of the state of a process for the purpose of technical diagnosis and sample identification were carried out. At the same time, some of the data processing operations in such IIS were always carried out instrumentally in sensors, measuring circuits, amplifiers and other analog units.

IIS underwent their most extensive development in the late 60's, with the inclusion of minicomputers in their makeup. Minicomputers are, of course, relatively inexpensive, are small in size and easily controlled (including programming), and have other relatively high-level technical characteristics. The following statement is apropos here: "Minicomputers are most properly considered as being the same kind of technical equipment as oscillographs, meters and spectrographs" [6]. The inclusion of minicomputers in IIS led to a sharp increase in the number of IIS developed. It suffices to note that at the IIS-75 All-Union Conference (Kishinev) more than 100 reports were presented on the structural characteristics and operation of IIS incorporating minicomputers.

The presence of minicomputers within IIS made it possible to switch from performing a number of measuring and data processing operations instrumentally according to a rigid unchanging program to programmed variation of the structure and composition of the operating functional units of the complex. At the same time, the utilization of minicomputers in IIS necessitated the solution of new

problems: especially those connected with formal description of procedures for collection and processing of measurement information in accordance with the metrological features of such IIS. It may be stated that the combining of the measurement section and the digital computer led to the emergence of the second generation of IIS.

Typical of second-generation IIS are: addressed or adaptive data collection, predominantly programmed computer processing of information, use of small-scale and medium-scale integration microelectronic devices, and the modular principle of system construction.

The unification of the measuring section with the computer gives the system universal properties: it is becoming possible to perform the functions not only of an IIS, but also (by adding certain blocks) of automatic regulation and control systems.

In order to automate industrial processes, so-called control computers (UVM) such as the Dnepr, Elektronika-100, M-6000, M-40, M-400, SM-1, SM-2, SM-3, SM-4 and so on have been developed. In these, the computer is connected by a communications link to a unit which contains the measuring section (in addition to sensors and measuring circuits) required for the obtaining of measurement data from the controlled facility and its transmission to the computer, and blocks which produce the control signals. In IIS too the latter are required, for example to organize tests of the process being studied.

In control computers the simultaneous operation of measuring blocks in the data links to the process is effected through peripheral interfaces. These make it possible to connect a rather large number of peripheral units (information sources and receivers), including measuring units, with the central processor and internal memory of the computer. IIS based on control computers are currently in wide use and show unquestioned promise of further development [7,8].

The creation of IIS based on control computers naturally calls for the development of blocks which are absent in the communications section but are necessary for operation of the system (most frequently sensors and measuring circuits), interface units for these, and also specific algorithms and programs to control collection and processing of information. The existing software of the computer should be used in making up the programs [8].

There is another way to provide simultaneous operation of the measuring section of the IIS and the minicomputer. This differs from the other by effecting the connections via standard digital interfaces, which offer more flexible organization of the interaction of the functional units with each other or any computer or control computer than could be provided by a control computer itself. Accordingly, G. I. Kavalero's [9] designation of this variant as an extremely important type of technical equipment (called by him the measurement and computation complex (IVK)) which should be studied and put into commercial production is correct, productive and timely.

Article [9] gives the following definition of the IVK: "We may with advantage agree to use the term "measurement and computation complex" to mean an automated measurement and data processing unit designed for the study (or monitoring or testing) of complex facilities consisting of a collection of program-controlled units (measuring, computation, auxiliary) with a modular block structure (of both function and design), and a certain communications organization, for the collection, conversion, storage, processing and transmission of measurement, instruction and other information in an appropriate form, which includes operations on the process being studied. The IVK also includes software."

The performance, using IVK as well as computers, of the required functions is effected by the use of the appropriate algorithms for processing of information, which should be developed by specialists in IIS, automatic control systems and the like. Naturally the functions of such specialists will also include the development of specific devices such as the IVK which are not included in the core concept of the IIS. These include devices for reception and conversion of data (sensors, measuring circuits, other analog and hybrid measuring converters and so on) and for operation on the object of study or control (regulators, actuating mechanisms and so on). A characteristic of the IVK is its use of standard digital interfaces to effect simultaneous operation of digital blocks of the measuring and control systems. Currently standard digital interfaces have been developed which satisfy various requirements for throughput capacity, noise immunity, distance between blocks, number of functional blocks and so on. It appears advantageous to satisfy a broad range of practical requirements by using standard digital interfaces. Thus, for example, it is efficient to use the standard CAMAC interface [10, 11] in complex applications, the Hewlett-Packard H-P interface for applications of low and medium complexity, and an interface with sequential information interchange on a single channel, well shielded against noise, for complexes where the functional units are widely separated or where the operating conditions involve excessive noise. The CAMAC and H-P interfaces are recommended by the International Electrotechnical Commission (IEC) and by IEEE as international standards.

By using standard digital interfaces it is possible to unite, first, the functional blocks which perform individual functions and require interchange of information among themselves (e.g. switches, analog-digital converters, digital-analog converters) and minicomputers, and, second, functional units which perform rather complex functions (in particular multipoint monitoring and measuring devices of types K-200 and K-732, each of which has its own particular connections).

It is primarily complex functional units which should be connected with the standard digital interfaces, since the relative cost of interface units will then be small. Moreover there is little need to provide interface units for all blocks listed in the GSP [State Instrument System]. This is illustrated by the fact that Hewlett-Packard puts out only 10-15 percent of its products with the standard H-P interface.

In summary, it may be stated that the urgent tasks associated with the development of second-generation IIS include the following: intensification of the relevant scientific research [9]; faster commercial production of modern control computers and IVK's; and expansion of the front of efforts to develop IIS based on IVK and control computers.

Some Problems of Further Development of IIS

It appears that the greatest impact on progress in IIS can be expected, first, from efforts to use microprocessor devices, memory units and other regular LSI functional units wherever possible, and second, from further development of sensor systems which will make it possible to sense fields of physical variables and which are accordingly more universal in application. It is the extensive use of LSI microprocessor devices and other units and of system sensors in IIS that will lead to the emergence of third-generation IIS.

Let us consider some characteristics of third-generation IIS.

In third-generation IIS the use of microprocessor devices will make possible the processing and temporary storage of data near where it is collected. This will obviously make it possible to carry out simultaneous processing at several locations in the system, considerably decrease the flow of information, and effect more efficient interchange of data between functional units and higher levels of a hierarchical control system. General-purpose microprocessor devices (with program control) can be efficiently combined with specialized microprocessors (e.g. those designed for data reduction) and with matrix, homogeneous and other types of LSI computation and logic units [5]. In other words, information processing software and hardware will be combined within third-generation IIS on a new level.

Since the price of LSI microprocessor devices has dropped considerably and the variety of commercially produced LSIC is expanding, we may suppose that many IIS will be designed for specific requirements. Accordingly, considerable attention should be devoted to problems of planning systems and their software.

In measurement tasks it is especially important to have simultaneous measurement and processing of the measurement data. As regards digital data, immediate processing after only part of the measurement information has been obtained (e.g. one bit in bit-by-bit analog-digital conversion, one stage in a multiplex measuring system) is of considerable interest [5]. Such operation can be performed using specialized microcomputers and can be combined with ADC's.

In third-generation IIS even more importance will be accorded to standard digital interfaces, and programming will be simplified, thanks particularly to the use of interchangeable but rigidly programmed control units and to simultaneous operation of several processing and storage units according to a relatively simple algorithm.

Because of the distributed character (in space and time) of information collection, processing and storage, third-generation IIS may be called distributed IVK.

Important variants of third-generation IIS may include systems using spatial sensors and minicomputers and systems using microprocessors. In this connection we may consider the holographic measuring system, which contains a powerful tunable laser, a corresponding optical system, a system for feeding holographic interferograms to the M-400 control computer, and the necessary standard M-400 peripherals, as being an approximation to a third-generation IIS. A holographic measuring system is broadly applicable within a certain class of tasks. It makes it possible to measure the parameters of the macro- and micro-relief of deformation fields and mechanical stresses, to monitor complex surfaces and so on. The programs determining the sequences of procedures, and the input and processing procedures themselves, can be altered according to the task to be performed.

Also approximating to a third-generation IIS is an information collection and processing system, using several microprocessors working simultaneously in different subsystems, which feeds information to the central processor [13].

We now consider several research tasks associated with the development of third-generation IIS:

1. It is extremely important to develop and make available standard data collection and processing algorithms which can be efficiently performed using individual or grouped microprocessors serving one or several information sources and receivers. In this case a microprocessor interface can be used to connect the functional units with the microprocessors.
2. Efforts to develop new methods and equipment for metrological support of systems and to improve existing ones must continue.
3. In third-generation IIS the relative proportion of instrumental methods and procedures for collection and processing using rigid but easily changeable programs (e.g. interchangeable ROM modules) should be increased over second-generation IIS; the optimal combination of instrumental and programmed methods of information collection and processing must be determined.
4. Devices and software (probably also using microprocessors) to control IIS and their communication with the next stage of the hierarchical system of which they are a part must be developed.
5. ADC and DAC that can operate with microprocessors [14] should be developed and manufactured (perhaps in the form of LSI microprocessors).
6. Since the IIS is a hybrid (analog-digital) system, it is necessary to develop a standard analog interface which is compatible with standard digital interfaces. Currently there are practically no standard analog interfaces, and this lack frequently affects the quality of IIS that are developed and the time required to plan and especially to debug them.
7. Construction principles and methods of planning and modeling should be the center of attention of IIS specialists. A larger role for natural modeling

is not ruled out as LSIC and microprocessor devices become less expensive [14].

8. Standard microprocessor servicing units should be developed.

9. Major tasks lie ahead in developing and planning the employment of sensors to sense fields of physical values. It can be stated without exaggeration that new results in this area will have a significant effect on the work of the rest of the system. At the same time, unfortunately, it can be seen that the development of new sensors (including system sensors) has fallen significantly behind the development of microelectronics.

In conclusion we may summarize the main directions for work on IIS development in the near future as follows: an all-out effort to provide scientific and production support for the construction of second-generation IIS based in IVK and control computers; active preparation and effective construction and utilization of third-generation IIS: distributed IVK using microprocessors and other LSI components, and also new system sensors.

BIBLIOGRAPHY

1. K. B. Karandeyev. "Measuring Information Systems and Automatic Control," VESTNIK AN SSSR, No 10, 1961.
2. K. B. Karandeyev; and M. P. Tsapenko. "Problems in the Theory and Practice of Measuring Information Systems," in Kibernetika na sluzhbe kommunizma [Cybernetics in the Service of Communism], A. I. Berg, ed., Vol 5. Moscow, Energiya, 1967.
3. G. I. Kavalerov; and B. V. Karpyuk. Izmeritel'nyye informatsionnyye sistemy [Measuring Information Systems]. (Summary report at Second All-Union Instrument-Making Congress). Leningrad, 1965. (VNIIEP).
4. M. P. Tsapenko. Izmeritel'nyye informatsionnyye sistemy [Measuring Information Systems]. (Summary report at Third All-Union Instrument-Making Congress). Leningrad, 1970. (VNIIEP).
5. M. P. Tsapenko. Izmeritel'nyye informatsionnyye sistemy [Measuring Information systems]. Moscow, Energiya, 1974.
6. E. P. Opperl', ed. Mini-EVM [Minicomputers] (Collection of Articles). Moscow, Mir, 1975.
7. B. N. Naumov. "The International System of Small Computers," PRIBORY I SISTEMY UPRAVLENIYA, No 10, 1977.
8. Ye. A. Dubovik; G. A. Yegorov; and V. A. Zimin. "Questions of the Construction of Measuring Information Systems Based on the Computers of the Unified Series," PRIBORY I SISTEMY UPRAVLENIYA, No 12, 1977.

9. G. I. Kavalerov. "Measuring and Computation Complexes," PRIBORY I SISTEMY UPRAVLENIYA, No 11, 1977.
10. I. F. Kolpakov. Elektronnyaya apparatura na linii s EVM v fizicheskom eksperimente [Electronic Apparatus On Line with a Computer in Physical Experiments]. Moscow, Atomizdat, 1974.
11. A. V. Kutsenko; B. A. Polos'yants; and Yu. B. Stupin. Mini-EVM v eksperimental'noy fizike [Minicomputers in Experimental Physics]. Moscow, Atomizdat, 1975.
12. A. G. Kozachek, ed. Golograficheskiye izmeritel'nyye sistemy [Holographic Measuring Systems] (Collection of scientific works). Novosibirsk, 1976. (Novosibirsk Electrotechnical Institute).
13. A. K. Baums; A. L. Gurtovtsev; and N. Ye. Zaznova. Mikroprotsessornyye sredstva [Microprocessor Devices]. Riga, Zinatne, 1977.
14. E. I. Gitis. "The Influence of Microprocessors on the Structure and Methods of Planning of Systems and Instruments," PRIBORY I SISTEMY UPRAVLENIYA, No 11, 1977.

COPYRIGHT: Izdatel'stvo "Mashinostroyeniye", "Pribory i Sistemy Upravleniya", 1978

8480
CSO: 8144/2424

CYBERNETICS, COMPUTERS AND AUTOMATION TECHNOLOGY

THE AUTOMATED STATE STATISTICAL SYSTEM

Moscow EKONOMICHESKAYA GAZETA in Russian No 26, Jun 78 p 5

[Article by L. M. Volodarskiy, Chief of TsSY USSR [Central Statistical Administration]]

[Text] The document "Main Directions for Development of the Soviet Economy During the Tenth Five-Year Plan," approved by the 25th CPSU Congress, calls for improvement of the system of accounting and reporting and of statistical information in accordance with the growing requirements of management and planning.

Soviet statisticians see as their task the timely and full supplying of leadership, planning and operating organizations with scientifically-based statistical data which characterize the development of the socialist economy and culture; the improvement of accounting and reporting in the various sectors of the national economy; and increased expeditiousness in the processing of reporting data.

Further fundamental qualitative changes in statistical science and practice and the improvement of accounting and statistical information dissemination are directly connected with the development of the material and technical base of the TsSU USSR [Central Statistical Administration] and the development on this basis of an Automated State Statistical System (ASGS). Its incorporation will make it possible to decrease the time for processing of data, to obtain data with higher analytical properties, and thus to satisfy more fully the requirements of the management and planning of the national economy for statistical information.

The ASGS is an intersectorial multilevel system of collection and processing of statistical accounting information which makes possible the extensive utilization of mathematical economic methods, automated data banks, teleprocessing, electronic and other computer equipment, and also organizational equipment and communication facilities in the state statistical organs. It is one of the main functional links of the State Automated System (OGAS) which is to be developed in the country.

Within the OGAS, the Automated State Statistical System is to make possible the performance of the information tasks of collection, processing, analysis, storage and presentation of statistical and other necessary information concerning the status and development of the USSR national economy, natural resources and minerals, demographic and social phenomena, culture, the national standard of living and the course of fulfillment of the plans for development of the national economy, its individual sectors, union and autonomous republics, krays, oblasts, municipalities and regions.

First Stage of the ASGS Under Construction

The development of the ASGS will be conducted in several stages. At the end of the Ninth Five-Year Plan the first stage of the ASGS, consisting of 14 functional and 5 support subsystems, was put into commercial operation. Each of the functional subsystems in the first stage of the ASGS performs tasks of specific sectorial statistics, coinciding with the specialties of the sectorial subdivisions of the state statistical organs (functional subsystems for industrial statistics, agricultural statistics, labor and wage statistics and so on).

The basis of the functional subsystems of the first stage of the ASGS is complexes for electronic processing of statistical information (EOI) for the most labor-consuming tasks. Generally each complex includes a number of statistical operations with a common information base in the form of indicators with one or several statistical forms connected with the general program of statistical observation.

The unification of the tasks in the EOI complexes and the unified information base makes it possible to develop new output tables presenting important analytical information without increasing the quantity of raw data. Thus, for example, in the Main Indicators for Annual Operation of Industry complex, the amount of output information increased by 3.4 times through the production of new analytical tables.

The unification of the information bases for the individual tasks into unified information bases in the EOI complexes, and the utilization of unified classifications and nomenclatures made it possible not only to expand the range and increase the value of the output information, but also to minimize the amount of input information and to exclude to a significant degree redundancy and data incompatibility.

The system character of the EOI complexes is determined by the operation of all computer centers of the TsSU USSR system with uniform information, hardware and software, with transmission of the results from the lowest to the highest level of the ASGS on various data media of via communications channels. The development and incorporation of the system complexes of the EOI made it possible to unify all computer centers in the TsSU USSR system into a single computer network.

A total of 46 EOI system complexes and more than 100 local complexes were incorporated in the first stage of the ASGS. The amount of information that can be processed by them amounts to 40 percent of the total information in the computer systems of TsSU USSR at the republican and oblast levels of ASGS and 54 percent at the union level.

In developing the EOI complexes, a major effort was made to unify the primary statistical reports from the enterprises and organizations and the forms of surveys, inventories and summary statistical accounts developed by the organs of TsSU USSR.

Recently the Central Statistical Administration has developed and published a unified typology for initial documentation for all the major accounting areas and directions for its application. In addition it has developed standard interdepartmental forms for primary accounting documentation which are compulsory for all enterprises and organizations.

The incorporation of the first stage of ASGS has made possible a significant decrease in the time for processing of information and statistical reporting. Thus, the time for periodic reporting has decreased by 1-3 days, for quarterly reporting by 3-6 days and for annual reporting by 10-60 days. Automated control over all the stages of collection and processing of information improves its quality and reliability. In addition, expenditures on the processing of significantly increasing quantities of information are decreasing, as is labor consumption. It is sufficient to note that while the quantity of information increased by 41 percent during the Ninth Five-Year Plan, the expenditures on its processing increased by only 14 percent and the labor consumption for the processing of an information unit decreased by almost 60 percent.

The utilization of the ASGS technical base for TsSU USSR and the enterprises and organizations of the national economy has made it possible to increase the amount of work for the TsSU USSR system as a whole by 2.5 times over the Ninth Five-Year Plan. If the information now being processed by computer in the form of EOI complexes was processed as it was previously, on punchcards and keypunch machines, 20,000 additional persons would have to be employed every year.

An important direction in efforts to develop the ASGS which have been performed during the Tenth Five-Year Plan is the planning and commissioning of the second stage of the ASGS, which differs primarily by the development of automated data banks (ABD).

Based on Automated Data Banks

The development of ABD for the ASGS is a necessary precondition for improvement of comprehensive economic analysis and the extensive utilization of mathematical economic methods. The existence of automated data banks expands the possibility for utilization of combined groupings, correlation methods, and factor analysis, increases the analytical character and comparability of statistical data and makes it possible to meet more fully the demands of the management and planning organs for statistical information and the necessary

reference tables. The ABD facilitates the further development of functional subsystems through the development of information data bases which include intersectorial indicators common to various subsystems (such as indicators of labor, wages, fixed capital, profits, profitability and production costs).

The incorporation of automated data banks creates the conditions for the further unification of reporting documentation and coordination of reporting forms and the quantities of reporting indicators within them, as well as coordinating information flows, since a large number of indicators of a stable nature (such as plan and normative data, various coefficients, data from previous periods and so on) will be permanently stored in the ABD.

The operation of the automated data banks will be supported by the use of unified information support and software, centralized catalogs, dictionaries, classifiers and identification systems, unified standards and norms. This will open up greater possibilities for extensive exchange of statistical information in the ASGS with functional and sectorial automated systems at all levels for the purpose of comprehensive analysis of the development of social production and the further improvement of the management of the country's national economy.

Efforts to develop experimental ABD are under way at present on three levels: on the union level in GVTs TsSU USSR [Main Computer Center of the Central Statistical Administration], on the republican level in the republican computer centers of the TsSU of the Belorussian and Estonian SSR's, and on the oblast level in the computer center of the statistical administration of Tomskaya Oblast. After conclusion of experimental work it is planned to use the planning aspects of these ABD's as a standard for the development of automated data banks in other computer centers TsSU USSR system.

The operating experience of the TsSU USSR computer system indicates that concentration of data processing in large computer centers makes possible comprehensive integrated processing, decreases the cost of processing, makes possible a constant and planned load on the computer equipment and makes it possible to minimize duplication in the collection, preparation, storage and processing of economic information. This creates the preconditions for the transition to a higher quality level of operation of computer equipment and data transmission facilities in the collective-use mode.

In the Collective-Use Mode

The advantages of the collective-use mode for computer equipment are becoming more fully evident as computer capacities and information files are concentrated in territorial computer centers. In view of the national economic expediency of such utilization of expensive computer equipment produced by our industry, the computer center network of TsSU USSR is being expanded with consideration of the development of the state network of territorial collective-use computer centers. Currently the TsSU computer system not only services the first stage of the ASGS but also performs computation work on a contract basis for more than 87,000 enterprises and organizations of the USSR national economy.

The TsSU USSR has agreements with a number of ministries and departments for the processing of economic information (USSR Ministry of Agriculture, Stroybank [All-Union Bank for the Financing of Capital Investments], Tsentrosoyuz [Central Union of Consumer Societies], social support agencies and others). The main subject of mechanized processing for the above-mentioned enterprises and organizations is accounting. By introducing automated processing of accounting information we are attaining the necessary systematization and unification of accounting nomenclature and primary documents, expanding the analytical nature of accounting, increasing its reliability and expeditiousness and decreasing the labor consumption of manual operations by bookkeepers, giving them more time to devote to monitoring and analytical functions.

The extensive utilization of standard plans and standard planning solutions is of considerable importance for improvement of accounting through automated processing.

For many years TsSU USSR has been developing standard plans in response to orders from ministries and departments and has been supplying these to their computer enterprises and requesters (between 1962 and 1977, 143 standard plans and standard planning solutions were developed).

The experience accumulated in these directions has enabled TsSU USSR to pursue efforts to develop four experimental collective-use computer centers as a fundamentally new form of centralized comprehensive servicing of enterprises and organizations.

TsSU USSR considers that the development of collective-use computer centers (VTsKP) should be carried out on the basis of the computer system of a single ministry or department (VTsKP base system). In this process it is inexpedient to develop a VTsKP on the basis of computer centers which are performing the functions of sectorial or enterprises automated management systems.

After coordinating them with the base system, Gosplan USSR, the State Committee on Science and Technology and the USSR Ministry of Finance must accelerate their solution of organizational, methodological, engineering and finance problems associated with the development and operation of VTsKP. In work on the development of the VTsKP net, more active participation by ministries and departments whose enterprises and organizations will be VTsKP subscribers must be called for.

The further development of the automated system of the TsSU USSR is connected with the improvement of the organizational forms for utilization of modern computer equipment and the statistical information system under automated collection, storage and processing of data.

[Photo caption] In the Main Computer Center of TsSU USSR statistical information is processed on Unified-System computers using modern procedures, which makes it possible to obtain the required statistical data in a shorter time and with minimal expenditures. Photo: In the computer room of the GVTs TsSU USSR; Technician L. Kuz'mina at the console.

8480
CSO: 1870

CYBERNETICS, COMPUTERS AND AUTOMATION TECHNOLOGY

AUTOMATED SYSTEM FOR PLAN CALCULATIONS IN UZBEK SSR

Tashkent EKONOMIKA I ZHIZN' in Russian No 6, 1978 pp 64-67

[Article by G. Zakirov, director of the Information and Computing Center of the Gosplan of the Uzbek SSR, candidate of engineering science: "ASPR [Automated System for Plan Calculations]: Prospects for Solution"; passages enclosed in slant lines printed in bold face]

[Text] One of the resolutions of the 25th CPSU Congress was "Improve the organization and methods for drafting national economic plans and reduce their compilation time." An efficient tool which makes it possible to successfully realize this party requirement is the automated system for plan calculations--ASPR, which has been called upon to become, on the scale of the entire country, the main link of the state automated system for acquisition and processing of information (OGAS). Development of the ASPR is one of the major directions in improving planning, aimed at strengthening the scientific validity and raising the quality of plans based on applying economic-mathematical methods and using computers. Therefore, the development and introduction of this system into the practice of planning is receiving great emphasis today in all of the union republics.

The first section of the ASPR is currently operating at the Gosplan of the Uzbek SSR. This system handles 518 calculations for all the leading sections of the annual national economic plan, including capital investment, material-technical supply, agriculture, and the sectors of industry. In agriculture, for example, 83 percent of the calculations for the production plan and all the calculations for compilation of the consolidated development plan have been automated. For the time being these are largely direct plan calculations, that is processing on the computer the draft plans of the ministries and departments for the purpose of obtaining generalized data in various

profiles for the republic. This is making it possible to significantly reduce the time and labor intensity of the operations, but it is a long way from opening up the potential capabilities of the system.

The greatest effect from the ASPR can be obtained first of all from /solving optimizational, balance, forecasting and multivariant problems on the computer,/ which are of major importance to the national economy. The first steps in this direction have already been taken.

The task "optimization of the fuel balance in the Uzbek SSR for 1976-1980" was worked out and calculated on a computer by the information and computing center together with the departments of energy and fuel industry of material balances and plans for distribution of the Gosplan of the Uzbek SSR under the direction of A. K. Irgashev, the first deputy chairman of the Gosplan. In doing so, 76 alternative solutions were obtained and analyzed in a short time. Using traditional methods without computers, this would have been simply inconceivable. The results of the solution to this problem were approved by the Gosplan of the republic and their use in the practice of planning promises a substantial economic effect.

Working drafts of the solution to other optimization problems have already been prepared: the plan for production of building materials, alternative calculations for the rate and proportion of industrial development, composition and structure of light industrial products, development of production of non-metallic materials, output of local industrial products in an oblast profile, and development of the industrial base of water resources construction.

What is the essence and meaning of optimization calculations? As an example let's take the problem "alternative calculations for definition of the rational structure and rate of growth of industry." In the predraft stage of compilation of the national economic plan, the departments of Gosplan work out the basic indicators of industrial production in the republic. In doing so, they start with the data of the five-year plan, the level achieved in the reporting year and the expected fulfillment of the plan in the current year. The volume of industrial production is linked to available capacity, the use of it, to the input of new capacity through capital construction, and to raw materials.

To perform these calculations the departments of the Gosplan need data on the volume of industrial production in the profile of the ministries substantiated by such qualitative indicators as labor productivity, profit, capital intensiveness etc.

The above-named problem was defined and solved to provide Gosplan workers with such data.

The basis of the solution to this problem was the unity of the economic categories of rate and proportion. A study of this unity has made it possible to define in a mathematical expression the functional dependence of the growth rate and proportion of individual sectors on the growth rate of the entire industry as a whole.

As is known, this indicator is determined by the five-year plan. However, in the course of fulfillment of the annual plans, deviations show up which are associated with the differences in industrial capabilities for the years of the five-year plan. For this reason, limitations caused by the availability and use of capacity and provisioning of raw materials are placed on the rate of growth of production. A special study was made to reveal the degree of these limitations. In doing so, the upper limits on the rate of growth were defined proceeding from the maximum use of capacity and complete provisioning of raw materials. A special condition was introduced which reveals the dependence of the calculated rate of growth on possible limits. Thus, the growth rate indicators, obtained as a result of the solution to this problem, in advance were limited to intervals reflecting the practical capabilities of the industrial production of the sectors. These calculations were made for 80 ministries and departments. Analysis of them showed that through optimization of the structure of industrial production in the defined limits of growth shaped by fixed capital, number of industrial production personnel and volume of capital investment, the output per worker increased on the average by 8.2 percent, the return on investment by 6.6 percent, and the expected savings from introduction of the results of the calculation was 141.8 million rubles.

Nearing completion is the work on computer assisted compilation of the balance of equipment in physical and cost terms which makes it possible to link the indicators of allocated equipment and capital investment for all holders of capital taking into account orders and quotas for use of surpluses of unassigned equipment. According to preliminary calculations, the economic effect from the solution to this problem was 2.6 million rubles. Expanding the range of calculations for this balance will make it possible to achieve an even greater effect which will be expressed in revealing unassigned equipment and its redistribution.

The main direction of the effort in the ASPR on use of balance methods is the transition /from an intersector balance in cost terms to physical intersector, and then also to interdepartment balances./

The primary reason why the intersector balances are seldom used in the practice of planning is that they are compiled in a sector profile while Gosplan in its work needs a departmental, that is an address profile of the plan. For this purpose, the information and computing center together with the Scientific Research Economic Institute of the Gosplan of the Uzbek SSR is developing a dynamic model of the intersector balance in coordination with the address interdepartmental balance.

/The application of program-goal methods of planning/ open up great possibilities for raising the efficiency of ASPR. Optimization, balance, and forecasting methods and models already in themselves yield a significant effect, but only the unification of them provides a qualitatively higher level of planning. The base for this unification is the program-goal method of planning, the necessity of using of which was indicated in the resolutions of the 25th CPSU Congress.

The information computing center of the Gosplan of the Uzbek SSR has already done specific advance work in developing the software for such methods and intends to use them in practice in the current five-year plan in preparation of plan decisions.

/The transition from batch processing of information to the conversational mode/ is also planned in the near future. The technology of calculations on computers currently looks like this: the data obtained by the information computing center from the departments of the Gosplan is punched and entered into the machine and the results obtained from the printer are returned to the departments. In the process, any changes or corrections require repunching and recalculation on the computer. This is the method of the so-called batch processing of information. When operating in the conversational mode, the results of the calculations are output to displays (device for visual presentation of information on a cathode ray tube), located in the departments of the Gosplan, and all the necessary corrections are input immediately from the console directly to the computer. Only after the final inspection of the results on the screens is the command transmitted to print. In other words, Gosplan workers will have direct access to the computer from their own work places. In the process, the realization of the multi-program /mode/ will make it possible for dozens of specialists to work simultaneously with the same computer, and consequently to use machine time a dozen times more efficiently.

A very important area for raising the efficiency of ASPR is ensuring the systematic character of developments, that is mutual /coordination of individual tasks and subsystems within the ASPR,/ as well as direct /coordination of the ASPR with other sector and departmental ASU/ [automated control systems] for the purpose of reducing the existing enormous document turnover, and primarily, solving the problems of planning within the framework of a single republic automated control system using the information and computing resources of all the sector and departmental ASU's included in it.

The primary goal of the interaction of the ASPR with other ASU's is to ensure coordination in solving plan problems introduced into the ASPR and corresponding ASU's. To achieve this goal it is necessary:

To ensure the formation of plans for development of sectors in accordance with indicators of the future plan, directives, and test figures;

To coordinate the sector plans for development with allocated resources;

To jointly analyze the activity of the sectors for fulfillment of plans, to introduce adjustments into them and to use the data of this analysis to solve problems of subsequent plan periods;

To ensure methodological, information, program and technical compatibility;

To expeditiously coordinate individual indicators of drafts of the plan by using prompt communications (teletypes, video terminals);

To reduce duplication of plan calculations;

And to raise the reliability of the processed information.

Helping to solve these problems will be the instructions developed by the information computing center of the Gosplan of the republic together with the Institute of Cybernetics and the Computing Center of the Academy of Sciences of the Uzbek SSR. These instructions describe the methods of revealing the plan-economic problems of the sector ASU's, being solved in the systems, and define the subsystems and units in which these problems are solved. Models of their presentation have been developed to ensure the capability of exchange of information using communications.

The source data for solving plan-economic problems is input into the information and computing center of the Gosplan of the Uzbek SSR using the problem-oriented set of programs of the input-output system "Dokument" designed for the "Minsk-32" computer. These machines require specific methods for describing input data and in connection with this the problem of putting

the data received into the standard form arises when organizing interaction with other systems. For this, buffer programs are being developed which provide the capability of receiving and transmitting information from various types of computers.

An experiment was carried out this year on the coordination of problems which have gone into the first section of the ASPR of the Gosplan of the Uzbek SSR with the problems of the ASU's of 96 ministries, departments and enterprises of union subordination. The interaction of the ASPR with the sector ASU's will make it possible to compile draft plans not on the basis of data obtained from the departments of the republic's Gosplan, but on the primary information from the ministries and departments. However, this is possible only when there is a single system of classification and coding of technical-economic information. /The introduction of the national classifiers of technical-economic information (OK TEI)/has been organized in the republic for the purpose of automation of the storage and use of the classifiers in the RASU [republic automated control system]. This will make it possible to use standard codes in all automated control systems and will provide intercourse between the machines in a common language. The necessity for the huge amount of work in coding and decoding required during exchange of information between different systems--the component links of the republic automated control system--is declining.

The chief organization for management of the OK TEI in the republic is the information and computing center of the Gosplan of the Uzbek SSR which is currently engaged in supplying the all-union classifiers to the computing centers of the ministries and departments of the republic--the subscribers of the centers of management of the OK TEI.

Further. Raising the efficiency of ASPR is inseparably linked with /reducing outlays for design./ This is being achieved in two ways: the first of these is /standardization of design solutions and use of the developments of other union republics./ The main computing center of the Gosplan of the USSR has compiled a coordinated plan for design of the ASPR of the union republics. Under this plan all the computing centers of the republic gosplans have prime responsibility in the country for a particular subsystem. As soon as the developments are ready, they are copied and sent to the gosplans of the union republics as standards. In particular, the Gosplan of the Uzbek SSR has prime responsibility of the subsystem "Irrigation and Land Reclamation."

The second way is the /application of algorithmic methods of design./ The technique of algorithmization developed by the

Institute of Cybernetics and the Computing Center of the Academy of Sciences of the Uzbek SSR presupposes development of general purpose software and an information base for classes of problems united by the characteristic of their solution. Relying on this technique, we intend to make extensive use of automated data banks, packages of applied and scientific programs, special operating systems oriented to realization of economic problems.

The information and computing center of the Gosplan of the Uzbek SSR has already assimilated a package of programs for analysis of the dynamics of economic indicators, on the base of which will be functioning models for predicting indicators of development of the national economy of the republic. A package of application programs is also being used to solve optimization problems. In particular, the programs are used for calculations for the longterm development of the cotton cleaning industry. A data base management system has been proven using test files and we will now be working on individual subsystems using data banks. This will make it possible to significantly reduce the time spent by programmers on working out various problems of the ASPR, but the main thing is that it will provide the capability of solving various plan problems based on one information resource (data base) which is an indispensable condition for the systematic character of the ASPR. You see, unique source information is currently prepared practically for each subsystem and problem of the ASPR which is frequently duplicated in other problems and subsystems.

Such are the primary measures for raising the efficiency of automated systems for planning calculations of the Gosplan of the Uzbek SSR, and our information and computing center is now working on the implementation of these measures.

PHOTO CAPTION

1. p 66 Hungarian specialists becoming familiar with the operation of the IVTs [Information and Computational Center] of the Gosplan of the Uzbek SSR. (Photo by A. Kudryashov)

COPYRIGHT: "Ekonomika i zhizn'", 1978

8545
CSO: 1870

COMPLETE MINIATURIZATION IN INSTRUMENT BUILDING, COMPUTER TECHNOLOGY AND ELECTRONICS

Moscow PRIBORY I SISTEMY UPRAVLENIYA in Russian No 8, 1978 pp 59-60

[Article by Doctor in Technical Sciences Yu. R. Nosov]

[Text] The results of the Sixth All-union Contest for the best work on complete miniaturization of electronic devices, conducted by the Central Administration of the Scientific and Technical Society for Electronic Systems imeni A. S. Popov, are now in.

The main trend reflected by the works submitted in the competition (totalling about 60) was the utilization of modern microelectronics in radio electronics, instrument building and communications. Large scale integration (LSI), SHF microelectronic devices and optical electronic devices were most frequently seen.

Three entries were dedicated to semiconductor memories. The series K565RU1 microcircuit is a 4096 bit RAM. The short write, read and select times (700, 500 and 300 ns, respectively) allow this circuit to be used as a computer main memory. The advantages of the series include low power consumption (10 μ W/bit in the store mode, and 80 μ W/bit in the retrieve mode) and compatibility of information output with TTL circuits. The microcircuit is manufactured using modern technology. Some 20,000 n-channel MOS-transistors with "self-integrated" polysilicon gates are placed on a silicon crystal 15 mm² in area. The elements are interconnected by means of a three-level layout.

Standard p-channel MOS-technology with single-level aluminum metalization has been used to create 1024 bit main-memory microcircuits. The combination of a dynamic memory matrix system (32 \times 32 elements) with a static electronic environment provides rather high speed for circuits of this class (about 400 ns select time) and low power consumption (\sim 100 μ W/bit for storage).

A prize was awarded to a system of semiconductor memory elements with a large degree of integration, including three microcircuits: a 256 bit storage matrix based on p-channel MOS technology, a decoder and read-write amplifier manufactured using bipolar technology on silicon with dielectric insulation. This combination of level-matched microcircuits based on different technologies allows a low product of specific power times speed to be achieved in these devices (\sim 300 pJ), with very compact devices and low cost per bit of stored information, as well as convenient interaction with the high speed logic elements of computers based on TTL integrated circuits.

The advantage of the system of microcircuits developed is illustrated on the example of a memory unit with a storage capacity of 1024×16 -bit words.

A single-crystal MOS LSI circuit, the series K145IP7 with fifth degree integration ($\sim 15,000$ elements), is designed for calculators for engineering calculations. The circuit contains logic units for information input to the calculator and the performance of simple operations (for arithmetic operations and the computation of trigonometric, logarithmic and exponential functions); a memory unit for the storage of intermediate results; and circuits for the control of the display. The microcircuit is based on standard p-channel technology. The K145IK8 microcircuit (electronic dialer) and K145IK11 microcircuit (semiconductor memory unit control circuit) are designed specifically for push-button telephone devices. Both of these microcircuits are based on MOS technology with additional symmetry. In combination with the well-known K564RU2 microcircuits (256-bit MOS transistor memory), these devices have been used to manufacture push-button telephone instruments with low power consumption, rapid dialing, and the ability to store a number for redialing.

The technological and systems engineering achievements in the area of LSI have allowed designers to make the transition to the creation of microprocessors -- the basis for instrument building in the future. One entry in the competition was an experimental model of a single-crystal, 8-bit microprocessor utilizing n-channel MOS technology. This microcircuit, containing $\sim 5,000$ transistors, can incorporate a universal system of instructions, including arithmetic and logic operation instructions, jumps, exchange of information with storage and peripheral devices, blocking and permitting of interrupts. Instruction cycle time is $2-9 \mu\text{s}$; input and output signal compatibility with standard TTL integrated circuit is provided. The microprocessors which have been developed are suitable for the building of universal microcomputers and controllers for use in testing and control systems, and to be built into scientific instrumentation and measurement systems.

Optical-electronic LSI devices include a matrix video signal shaper (VSS) based on charge-coupled devices. About 200,000 MDS elements are placed on a silicon crystal about 50 mm^2 in area. The use of 3-level polysilicon electrodes allows the influence of short circuits in one layer of the polysilicon to be eliminated. Thermal oxidation of the silicon in a mixture of oxygen with hydrogen chloride, in combination with gettering with phosphorus silicate glass has succeeded in reducing the density of surface states at the division boundary between oxide and silicon to 10^{10} cm^{-2} while increasing the storage time of the MDS structures to 10 minutes

The matrix VSS circuit has frame organization, performs alternate-line scanning of the image, and contains three shift registers. The input shift register allows a background charge to be input to the matrix, a digital matrix operation test to be performed, and information to be read even when interfering factors are present. The two output shift registers, in combination with MDS-transistor source repeaters, form a differential reading circuit.

The video signal shaper has a light sensitivity threshold of $5 \cdot 10^{-3}$ lx·s, a dynamic range of 100:1, a charge transfer efficiency of 0.998, and an output signal (from the maximum charge group) of 0.3 V. A linear video signal shaper based on charge-coupled devices, containing a single row with 1,000 resolution elements, has similar parameters.

A number of entries were dedicated to hybrid SHF microcircuits. A low-noise, GHz-range transistor amplifier is characterized by the fact that all of its passive components, interconnections and contact areas are made in a single process by thin-film technology and photolithography. The use of sapphire substrates and direct mounting (soldering) of transistor to the contact areas have allowed a sharp reduction in the parasitic reactance, improvement of heat liberation and, in this manner, achievement of the maximum possible number of active elements in the circuit. With a volume of ~ 20 cm³, a mass of ~ 50 g and a power consumption of ~ 0.35 W, the amplifier achieves a power gain of 25 dB with a noise coefficient of 6 dB in the 3.2-4.5 GHz frequency band.

An analogous thin-film technology was used to produce amplifiers in the UHF band (100-150 MHz) with an output power of 10-20 W. In addition to bodiless transistors, the active elements in the circuits include specially MOS vari-caps with high Q (up to 300-500) and a broad range of nominal capacitances (10-500 pf).

A transistorized amplifier module with a power gain of at least 13 dB and an output power of 7 W has been developed for the 750-850 MHz range. The module features planar construction using printed band transmission lines and contains type KT919A transistors as the attached active elements.

A hybrid shorted power divider, which also has simple planar construction and small size, achieves a nonuniformity of division of not over 0.4-0.6 dB in the 300-450 MHz band (2-channel) or the 700-1,000 MHz band (4-channel), with at least 24-17 dB decoupling between channels.

The field of electronic optics was represented in the competition by a series of entries consisting of optrons and indicators. The type AOD109 3-channel optron, designed for transmission of information through a galvanically decoupled circuit at up to 1 Mbit/s, as well as the type K249KN1 2-channel optical-electronic linear switch, for contactless switching of analog signals in a circuit with a nominal voltage of 30 V and a nominal current of 0.5 mA, are based on the same elements, highly efficient diode-optical couples. A typical value of impedance of the galvanic decoupling of the two instruments is over 10^{10} ohms. The K249KN1 instrument is convenient for use in digital-to-analog converters.

One important problem in optron technology -- the transmission of analog signals from various transducers through a galvanically decoupled circuit -- is solved by means of the differential optron. In this device, one radiator "works" with two identical photosensing diodes, one of which is the output circuit of the optical communication element, while the other is used to create a negative feedback loop and improve the linearity of the transfer characteristic. In microcircuits using a differential optron, the error in transmission of an analog signal has been successfully reduced to 0.5-2% in the -60 to +85C temperature range, at frequencies of up to $5 \cdot 10^4$ Hz.

The type AL307 series of light-emitting diodes, with red, orange, yellow and green luminescence, is based on a single semiconductor material -- gallium phosphide. The maximum light power, with a current flow of 10 mA, for instruments emitting light in these colors is 7, 5, 5 and 5 mcd, respectively. All of the instruments are made in the same miniature plastic body.

The type AOD109 3-channel optron, the type K249KN1 optical-electronic linear switch, a differential optron and the AL307 series of LED's have been exhibited at the Exhibition of Achievements of the National Economy of the USSR in the "Physics" Pavillion and at the Exhibition "Optoelectronics in Computer Technology, Instrument Building, Automation and Communications."

A digital semiconductor display with built-in control circuit counts electric pulses arriving at its input and displays their number in the form of luminescent numerals from 0 to 9, then forms a carry signal for the next digit. This scale-of-ten counter display is based on a monolithic 7-segment display unit which glows red, based on gallium arsenide-phosphide and a silicon SMOS control circuit. Both elements are mounted in a single plastic case with a volume of only 0.5 cm³. The creation of this controlled display will allow a significant decrease in the dimensions and weight of information display systems, greatly reducing the number of external solder connections (from 34 to 8), while standardizing the electric control signals. The low power consumption of the instrument (~ 70 mW) allows it to be used in microelectronic battery-powered devices.

An original circuit for controlling a powder-based electroluminescent indicator element has been designed, utilizing ferroelectric crystals. The operating principle of the device is based on the change in capacitance of a ferroelectric condenser when a voltage is applied. A single cell of the device consists of a series-connected ferroelectric (controlling) and electroluminescent (radiating) condenser. These elements have been used to create a green-light display with 126 independently switched elements, controlled by the signals of standard TTL microcircuits (2.4 V). The dimensions of the display are 150X125X20 mm³, the maximum brightness of the display is 18 cd/m².

The functions of an optical communication element and of visualization of the status of an electric circuit have been combined in an original optoelectronic device -- the optron indicator. This device includes a gallium-arsenide IR radiator, a silicon p-r-n photodiode, plus a film of antistokes luminophor, which transforms a portion of the IR power into green light. The brightness of the indicator is as high as 500-1,000 cd/m², the galvanic decoupling of the optron over 10⁹ ohm. The optron indicator is mounted on the end of a standard KT-21 chassis element and is sealed behind a plastic lens. Advantages of the device include low power consumption (30-50 mA) and high speed of the optron circuit (300-500 ns).

Among the other microelectronics elements (microcircuits and devices) entered, the following are of interest:

A series of highly interference-stable integrated logic circuits type K511, designed for use in numerically controlled machine tools, relay protection devices and automation devices for high-voltage power transmission lines, electronic automatic telephone exchanges, and also in automatic control systems in the areas of machine building, mining, metallurgy and transportation;

miniature piezoceramic filters based on the use of acoustical surface waves in a solid body, suitable for use in the 600-3,000 kHz range and providing signal suppression levels of up to 90 dB; the volume of the filter is not over 3 cm³.

An entire series of microminiaturized devices based on the use of acoustical surface waves has been developed for the 10-120 MHz IF range. The series includes delay lines, band-pass filters, devices for measurement of the phase difference of pulsed radio signals, devices for shaping and processing complex radio signals, as well as frequency discriminators, self-excited oscillators, devices for spectral and correlation analysis of radio signals, all built using ASW elements. The creation of these elements and devices was preceded by study of a number of piezoelectric materials (lithium niobate, piezoquartz, type TKBS piezoceramic) and various methods of excitation and reception of ASW.

The field of magnetic microelectronics was represented by the development of a number of multistable elements. The elements are based on cylindrical multilayer structures, the characteristics of which are determined by the superpositioning of the characteristics of individual layers, which have various values of coercive force. Under certain conditions, several (from 3 to 10) stable states can be achieved. The high-coercivity layer consists of a cobalt-copper alloy, the low-coercivity layer -- of a nickel-iron alloy, while copper is used as the intermediate layer. It is expected that the use of multistable magnetic film elements in memory devices will significantly reduce the volume of secondary electronic equipment in comparison to binary memories. A mockup memory of 16 four-digit trinary numbers served to illustrate this thesis.

Interesting work was submitted in the contest in the area of reducing the size and increasing the quality of secondary power supplies; the creation of a microelectronic cell of homogeneous matrix structure; projecting highly stable hybrid-film video amplifiers and wideband (0.1-40 MHz) 2-channel amplifiers with identical characteristics.

Several works were dedicated to the use of microelectronics and optoelectronics elements in various types of hardware.

The use of existing optoelectronic switching microcircuits and similar devices, optimal from the standpoint of increasing their speed and temperature stability, allows the planning of optoelectronic communication lines between digital computers and peripheral devices, distinguished by their high information transmission rate, reliability and interference rejection.

The use of single-crystal MOS-LSI devices in the BZ-18M engineering calculator has allowed its volume to be reduced to 37% of its previous size, while simultaneously reducing the cost of assembly operations in comparison to the prototype (the BZ18A).

Microelectronics has also penetrated into the area of hardware for medical and biological research, performing graphic recording of heart rates, analysis of the coordination of athletes, precise detection of points of biological information and transmission of medical-biological signals over a 6-channel telemetry system.

The contest showed that work is proceeding in the area of miniaturization of electronic devices; it proved the scope and degree of the contribution which modern microelectronics can make to instrument building and computer technology.

COPYRIGHT: Izdatel'stvo "Mashinostroyeniye". "Pribory i sistemy upravleniya," 1978

6508

CSO: 1870

UKRAINIAN GOSPLAN AUTOMATED PLAN ACCOUNTING SYSTEM

Kiev MEKHAUZATSIIYA I AVTOMATIZATSIIYA UPRAVLENIYA in Russian No 3. Jul/Aug/Sep 78 pp 31-35

[Article by Doctor of Economic Sciences M. T. Matveyev and Kandidats of Economic Sciences L. V. Shul'pin and A. A. Gatsa: "The Automated Plan Accounting System of Gosplan, Ukrainian SSR in Action"]

[Text] In October 1976 an interdepartmental commission adopted the first stage of the Automated Plan Accounting System (ASPR) of Gosplan, Ukrainian SSR.

The Ukrainian Gosplan ASPR belongs to the class of intersectorial automated data collection and processing systems. The purpose of its introduction is increased completeness, a solid basis and better quality of planning decisions through extensive utilization of mathematical economic methods and the newest types of computer facilities.

The fully developed ASPR will make possible the mechanization and automation of all the main formally-describable management and planning functions performed by the structural subdivisions of Ukrainian Gosplan. Characteristic of this system are specific methods of planned input into the development and operation of the republic's national economy as manifested in certain results (indicators) from its productive and nonproductive areas.

The first stage of the system consists of 23 subsystems grouped into the following main complexes: 4 resource balance subsystems; 5 summary functional subsystems; 11 sectorial physical production subsystems; and 3 subsystems for nonproductive areas.

The tasks are performed using mathematical economic models and algorithms carried out by the use of applied program packages. A total of 574 tasks are performed: 24 optimization tasks, 88 forecasting tasks and 14 balance tasks are among them.

Studies carried out by GlavnIIIVTs [main scientific research institute computer center], Ukrainian Gosplan, indicate that as of 1 January 1976 the average number of tasks being performed by OASU [Industrywide Automated Control

Systems] belonging to republican and union-republican ministries and departments and representing first stages of systems totaled 64, including 3.3 optimization tasks, while the corresponding number of tasks being performed by ASUP [enterprise automated control systems] of republican and union republican ministries and departments in the Ukrainian SSR was 29. Thus the ASPR is performing 9 to 19 times as many tasks an indicator of the position of this system among other ASU [automated control systems] operating in the republic.

In the first stage of the ASPR two groups of tasks are performed: those with data interconnections and those without; but the performance of these tasks is repetitive in nature and the results are used extensively in developing national economic plans. Some tasks included in the resource balance and summary functional subsystems have highly ramified information interconnections both among themselves and with tasks in the sectorial physical production and nonproductive area subsystems.

The makeup and nature of the tasks were chosen on the basis of general systems developments of GlavNIIVTs and the requirements submitted by the structural subdivisions of Ukrainian Gosplan, assuring that they would be methodologically compatible and objectively necessary.

Informational and mathematical compatibility of the tasks is assured in part by standardization of a number of design solutions involving hardware, the unification of the plan documentation, the development of universal methods of formal description of data and the employment of the proper operating systems and applied program packages.

The system hardware is based on the YeS-1020 computer (20,000 operations per second). The total expenditure on the development of the first stage of the ASPR, including expenditures on uncompleted stages of the work, came to more than 7 million rubles, including 2.5 million for the creation of fixed capital and 0.2 million rubles for working capital. Nonproductive expenditures on scientific research work and planning came to over 4.5 million rubles, almost twice as much as on system hardware. The specific capital expenditures per unit of ASPR capacity are still quite high (241 rubles per operation/second).

The ASPR processes 470 million characters of input data (about 200×10^9 operations per year) and gives Ukrainian Gosplan about 390 million characters of processed information a year.

Considering the ASPR as a system designed to significantly increase the quality of plans by conducting and establishing completion dates for multivariate calculations in which each plan variant is comprehensively substantiated and the plan indicators are optimized on the basis of fuller and more reliable data, we can state that the economic effectiveness of the system is characterized by two basic factors: increased plan quality and lower labor consumption in its development.

The quality of the plans in turn makes possible operational processing of the objectively necessary (and usually several times greater than under traditional planning methods) volumes of data and optimization of plan decisions.

"The main effect to be realized from ASOU," writes V. M. Glushkov, "stems from the fullness, timeliness and optimality of the decisions that are taken, and as a consequence the elimination of various types of organizational malfunctions."

"A second important effect, although a much smaller one, that will be produced by the ASOU is a saving of management work, which will enable us to decrease the management apparatus (or slow its growth) without affecting management quality."*

Approaches to determination of the economic effectiveness of the system should be in keeping with the stage of incorporation of ASPR developments, i.e. with the degree to which they implement the assigned functions.

For the second stage of Ukrainian Gosplan's ASPR, a more precise and efficient calculation of the economic effectiveness of the system is proposed, based on calculation of the effectiveness of the individual tasks. The existing methods of calculating the effectiveness of ASU on the sectorial level or the individual enterprise level are inapplicable for this purpose because of the necessity of taking into account the intersectorial character of decisions.

On the basis of V. M. Glushkov's suggestions, GlavnIIIVTs of Ukrainian Gosplan has conducted an analysis of the economic effectiveness of the tasks in the first stage of the ASPR.

According to the analysis the annual saving from the operation of the first stage of the ASPR amounts to 14.3 million rubles a year, including 12.8 million rubles from optimization of planning decisions: 1 million rubles from the processing of additional quantities of information (fullness); and 0.54 million rubles from decreased costs for computer work (saving of management labor). We add in the economic essence of certain optimization tasks performed in the sectorial subsystems of the first stage of the ASPR.

The Agriculture subsystem determines the optimal requirement for deliveries of mechanized farm equipment to agriculture. The essence of this task is the determination of the optimal load on agricultural equipment available at the beginning of the year resulting from the planned quantity of work, and if this quantity of work cannot be performed by available equipment, determination of the optimal amount of additions to the agricultural machinery inventory. The task is performed for a range of types of farms, oblasts and departments of the Ukrainian SSR. Account is taken of specific characteristics of 25 oblasts in the republic, 45 crops, 250 operations involved in their cultivation and 73 calendar periods of the agricultural year, and embraces 150 types of non-self-propelled agricultural machinery and 20 types of tractors and combines.

A huge volume of data equivalent to 500,000 numerical indicators is processed in performance of this task. The task is performed in steps by generalizing a descending slope in the space of double variables. The optimality criterion is minimum reduced expenditure for the entire complex of mechanized agricultural operations in the republic.

* V. M. Glushkov. Vvedeniye v ASU [Introduction to Automated Control Systems]. Kiev, Tekhnika, 1974, p 195.

By using the results of this task it is possible to optimize the structure of deliveries of agricultural equipment by types of equipment and oblasts in the Ukrainian SSR. The annual economic effect from the introduction of this operation into the planning process is about 3 million rubles for the republican national economy.

In performing this task in long-term perspective (15 years), the main requirements of scientific and technical progress according to the recommendations for improvement of agricultural equipment, soil treatment processes and the like recommended by scientific research institutes and machine testing and standardization stations are also taken into account.

A large economic effect will result from the performance of the tasks for drawing up of optimal plans for territorial placement of enterprises. For example, determination of the concentration of lumbering operations with optimization of transport links between the enterprises of the Ukrainian SSR Ministry of the Forestry Industry will make it possible to decrease production expenditures by 7 percent by increasing the level of comprehensive utilization of wood in lumbering operations.

Similar tasks are performed in the Construction and Construction Industry subsystem. The total savings accruing through optimization of capacities and location of construction industry enterprises is estimated at 1.23 million rubles a year.

Determination of the optimal quantity and breakdown of industrial products plays a major role in increasing the economic effectiveness of industry.

Thus through determination of optimal plans for the production of wool and linen cloth in the enterprises of the Ukrainian SSR Ministry of Light Industry, a saving of 700,000 rubles a year is being realized. In addition, performance of the complex of tasks in the Light Industry subsystem will make it possible to decrease the orders for cloth by the Ukrainian republican ministries and departments to 1 percent of the total orders made under the traditional information processing system.

The Food Industry of the ASPR determines the optimal plan for production of dry feeds for the Ukrainian Ministry of the Meat and Dairy Industry as a whole and for each of 25 oblast associations of the Ukrainian meat and dairy industry. This pursues the aim of a more complete utilization of the relevant production capacities in the Ukrainian SSR by increasing concentration and specialization of the production of dry livestock feeds.

The Transport subsystem performs a complex of tasks aimed at optimizing motor vehicle repair for 50 types of motor vehicles and 9 main types of repair for oblasts, ministries and departments. The calculations are performed by a multi-program complex which optimizes the association of holders of motor vehicles and machinery with the proper motor vehicle repair enterprises. Performance of this complex of tasks makes it possible to decrease the national economy's expenditures on deliveries of repair capital by 400,000 rubles a year.

These examples attest to the extremely high effectiveness of optimization tasks in comparison with tasks of a statistical-accounting and planning and reporting nature. However, the performance of planning and reporting tasks is also yielding a certain saving. Thus analysis shown that before the introduction of the first stage of the ASPR, the Material-Technical Supply subsystem was, because of the absence of accounting for individual varieties, failing to use about 2 percent of its ferrous rolled products available for delivery for their proper purpose: i.e. the requesters generally received the product on hand, part of which did not correspond to their orders (for example, instead of 45 x 45 mm square-section products the requester would receive 45 x 50 mm rectangular-section products and so on).

Since the incorporation into the planning process of a number of planning and accounting tasks, such substitution of ferrous rolled products has decreased sharply. The difference in expenditures per ton between the used and required varieties has become about 3 rubles a year for the republic. The annual saving from rational utilization of ferrous rolled products in the republic will, it is calculated, amount to about 75,000 rubles.

The annual economic effect from incorporation of the first stage of the ASPR is also rather high: 9.15 million rubles; the period for recovery of investment is 0.76 years and the period for recovery of all expenditures including incomplete activities is 1.1 years.

The average period for recovery of expenditures on the development of ASU's put into operation between 1971 and 1975 for the union-republican ministries and departments in the Ukrainian SSR is 2.2 years. Even an intersectorial system like the ASU MTS [automated management system for material and technical supply] of Ukrainian Glavsnab [Main Supply Administration], taking account of all the factors of economic effectiveness which are operative in the management, managed and associated systems, has a period of recovery of investment of more than 2 years and affords an annual saving of 5.26 million rubles with expenditures of 11.6 million rubles.

In determining the economic effectiveness of the first stage of the ASPR we have not taken account of savings realized from efficient organization of planning norms, improvement of analytical and organizational work, or savings accruing to the national economy through completeness and stabilization of plans for output volume over several quarters of a year.

The operation of the ASPR offers the possibility of full allowance in the planning process for trends in the social and economic development of the republic, and also the possibility of realizing in practice such important planning principles as comprehensiveness, optimality, range of variants and continuity in the development of national economic plans.

The experience accumulated by the developers of Ukrainian Gosplan's ASPR in designing and incorporating the system makes it possible to envision more extensive incorporation of the systems method of planning, making use of standard planning solutions, in the development and incorporation of the second stage of the system.

The plan for work on the development of the second stage of Ukrainian Gosplan's ASPR during the Tenth Five-Year Plan calls for expansion of the number of subsystems to be developed, the organization of tasks into complexes at the system level (system complexes) and also at the individual subsystem level (subsystem complexes) and the development of multi-use interconnected tasks at the ASPR subsystem level and also that of the sectorial ASU.

The plan calls for nearly doubling the number of tasks performed by the ASPR by 1980, in comparison with those which were operative when the first stage was commissioned. The system hardware will be significantly updated and supplemented, and not only by incorporating high-capacity multi-unit results of development of a system of peripherals. This will guarantee the possibility of attaining an even higher level of effectiveness for the system.

Revision completed 9 March 1978.

COPYRIGHT: UkrNIINTI, 1978

8480

CSO: 1870

UKRAINIAN SCIENTIFIC AND TECHNICAL INFORMATION SYSTEM

Kiev MEKHANIZATSIYA I AVTOMATIZATSIYA UPRAVLENIYA in Russian No 3, Jul/Aug/Sep 78 pp 39-43

[Article by Kandidat of Technical Sciences V. P. Tron', Kandidat of Philological Sciences D. D. Bakolas and Kandidat of Technical Sciences Ye. I. Gershgorin: "The Structure of the Intersectorial Automated Republican System of Scientific and Technical Information [MARS NTI]"]

[Text] The development of the algorithmic structure and the language apparatus of the MARS NTI [Intersectorial Automated Republican System of Scientific and Technical Information], which is an integrated system at a relatively high level, was based on the requirements of compatibility with other information systems of the GAS NTI [State Automated System of Scientific and Technical Information] and of assuring gradual development (implementation of new subsystems with no fundamental reconstruction of the system as a whole or of individual previously developed subsystems).

In addition the language apparatus and the complex of algorithms planned for use in the three subsystems of MARS NTI are oriented toward the Minsk-32 computer and its associated equipment.

Certain distinct design solutions [1,2] were used in the development of the original algorithm complex.

The MARS NTI developed by UkrNIINTI [Ukrainian Scientific Research Institute of Scientific and Technical Information] consists of subsystems for: data collection, processing and output; information storage; and selective distribution of information (IRI).

Its structure (which does not include the ancillary Statistika subsystem), made up of compatible modules which meet type and standardization requirements, can be described (see figure) in terms of the following functional blocks: document input; structural-logical control of documents; document indexing; storage of documents and their retrieval forms; search in the IRI mode; input of inquiries; structural-logical control of inquiries; indexing of inquiries;

storage of retrieval forms of inquiries (POZ); and printout of the relevant documents.

In document input the following functions are performed: selection of a routine depending on the medium and input device for the information (punched media, magnetic tape, remote units); reading of the specified portion of the information; and recording of the information in machine code.

The structural-logical control of the documents consists in checking of completeness of format; determination whether the data dimensions are allowable; and logical control of the contents of the individual fields.

Document indexing entails: lexical screening of the documents; morphological analysis of the Russian words in the text; coding of terms; and formation of the retrieval forms for the documents (POD).

Storage of documents and their retrieval forms consists in the formation of storage units and the storage of the documentary information (in document-POD pairs), and also organization of cumulative document files on magnetic tape.

The search in the IRI regime entails: selection of a search mode; performance of a nonthematic search; performance of a thematic search and identification of relevant documents.

The input, structural-logical control and indexing of inquiries and the storage of retrieval forms of inquiries are carried out in the same way as processing of documents.

The readout of the relevant documents includes: selection of the output program depending on the output device (alphanumeric printer, magnetic tape, remote unit); organization of the output format and the file of relevant documents; and the output of the relevant documents via the output device in question.

We now consider the most characteristic features of the MARS NTI.

No lexical or grammatical limitations are placed on the texts of input documents and inquiries. We note only that graphical symbols not used on UPDK and UPDL [card and tape equipment] may not be used and that abbreviations used in input documents and inquiries must be in accordance with the accepted standards.

The formats for entry of input information which have been developed are not designed for lexical or grammatical systematization of the input, but for identification of the data elements which will be used as search descriptors or will play a special role in later procedures but cannot be algorithmically separated from the text.

The format for entry of input documents in MARS NTI meets current general requirements for the structure of abstracts. The format for entry of inquiry inputs is determined by the characteristics of the information retrieval language and the system as a whole.

The utilization of such a simply-structured format for entry of documents and the absence of limitations on input text of documents is one of the most important preconditions for realizing language compatibility of the MARS NTI with other systems. The entry elements which are produced in this format are universal and are also distinguished in all known formats of other systems, so that the development of converters to translate the machine-readable data of any system into the MARS NTI format presents no particular difficulty.

In addition, the use of natural language without lexical or grammatical input limitations creates a good basis for the development of a dialog section of an AIPS [automated information retrieval system].

The output structure of documents corresponds to the input structure and meets the requirements of bibliographic and abstracting description of documents, making it possible to organize the automated production of catalogs, descriptions of new acquisitions and other information publications on the basis of an AIPS.

The lexicon of the IPYa [information retrieval language] which forms the basis for indexing the documents and inquiries includes: a basic Russian terminological vocabulary; words in languages written in the Roman and Cyrillic alphabets; and numbers and various signs.

In order to separate out Russian works of a terminological nature a dictionary of forbidden forms including high-frequency words from the general scientific and neutral strata of the Russian lexicon that typically occur in abstracts of scientific and technical documents is employed. The dictionary of forbidden terms includes 488 lexical units representing both full and auxiliary works of the Russian language.

The assignment of indexing terms (keywords) to the documents and inquiries is done automatically and consists in extracting from the text of the document the words which are in the dictionary of forbidden forms. All the remaining lexical units are the keywords from which the retrieval form of the given document or inquiry will be formed.

The processing of lexical units in the input texts for transfer from the source language into the data language is done automatically and consists of identification of indexing terms by removal of the nonterminological part of the lexicon; identification of words by recognition and removal of inflectional affixes; and standardization of the length of the text elements by compression of 5 symbols of lexical elements consisting of 6 or more.

The identification of word stems is carried out by a morphological analysis algorithm which was developed on the basis of statistical data on the correlations between word endings and grammatical characteristics. This algorithm is designed to analyze language texts with no thematic or lexical limitations and makes possible the identification of word stems with a probability of 0.95.

The compression of lexical units to five symbols is carried out by a coding algorithm and is aimed at assuring the most economical storage of words in the memory of the Minsk-32 computer.

The lack of descriptor dictionaries and automatic indexing renders the system independent of the subjects in the information files and makes it suitable for processing of multi-area holdings.

In the absence of a thesaurus, paradigmatic relationships between terms are specified in the inquiry. In this way, making use of so-called "conventional synonyms" which are added to the lexicon, a special micro-thesaurus is created which defines only a one-to-one relationship between terms, that of "conventional synonyms." The meaning of "conventional synonym" in this case is "associated by some semantic relationship," so that this concept covers all paradigmatic relationships which are recognized from a lexicographic viewpoint: synonymy, class relationships and associative relationships. The logic of the system provides for complete interchangeability of the conditional synonyms ("either-or").

Document search through inquiries to MARS NTI is carried out by: establishing the optimal ratio between the number of documents and of inquiries simultaneously held in memory and selection of the most effective procedure for sorting of the documents and inquiries during the comparison process (selection of a search mode); identification of documents which satisfy the bibliographic requirements specified in the inquiry (non-thematic search); comparison of the content of the document texts with the inquiry and identification of relevant documents (thematic search).

The criteria of semantic correspondence used in the thematic search are not rigidly specified but depend on the number of terms in the inquiry (the fewer terms in the inquiry, the more rigid the criteria for semantic correspondence used in the search).

Document search conditions may be varied (e.g. only according to bibliographic characteristics or with use of the abstract; according to specified levels of relevancy or all relevant documents, and so on) depending on the requirements of the user, the nature of the inquiry and the type of output unit (remote unit or alphanumeric printer).

The complexes of algorithms and programs which have been developed have made it possible to assure technical characteristics of the automated processing of information which are on the level of current standards (the searching of 100 documents on a single inquiry takes 6 seconds). In addition the qualitative characteristics of the information retrieval using the present algorithms are not inferior to comparable indicators for the best-known automated information systems (completeness of search, 74 percent; accuracy, 85 percent).

BIBLIOGRAPHY

1. D. O. Avetisyan; I. K. Zuyus; R. A. Nashlyunas; and L. F. Sarukhanyan. Opit postroyeniya i expluatatsiya respublikanskikh avtomatizirovannykh sistem nauchno-tekhnicheskoy informatsii [Experience in Design and Operation of Republican Automated Scientific and Technical Information Systems]. Moscow, VINITI, 1974.
2. G. G. Belonogov; and V. I. Bogatyrev. Avtomatisirovannyye informatsionnyye sistemy [Automated Information Systems]. Moscow, Sovetskoye Radio, 1973.

Revised version received 17 December 1977.

COPYRIGHT: UkrNIINTI, 1978

8480

CSO: 1870

MARS NTI RETRIEVAL SOFTWARE DESCRIBED

Kiev MEKHANIZATSIYA I AVTOMATIZATSIYA UPRAVLENIYA in Russian No 3, Jul/Aug/Sep 78 pp 57-58

[Article by Kandidat of Technical Sciences G. A. Solov'yeva: "The Structure and Functions of the Software of the Selective Information Distribution Subsystem [IRI] of the MARS Scientific and Technical Information System"]

[Text] The selective information distribution subsystem (IRI) is one of the main subsystems in the Intersectorial Automated Republican Scientific and Technical Information System (MARS NTI). The software of this subsystem is a package of standard programs which carry out, using the dispatcher of the Minsk-32 computer, the function of automated selective information distribution.

All the programs in the package are composed in a symbolic coding language as library packages in accordance with the requirements adopted for the software system of the Minsk-32 computer.

The program package of the IRI subsystem includes: standard programs from the Minsk-32 software, programs for input, control, indexing and entry on magnetic tape of documents and their search forms and inquiries and their search forms; a program for performance of search procedures; programs for documentation of files at all stages of processing of the information; and a program for processing of statistical data.

The input of documents and inquiries is carried out by the subsystem using the codes of GOST [All-Union State Standard] 10859-64, MTK-2 and KOI-7, directly in the input devices of the Minsk-32 or remotely by teletype or Videoton-340 devices connected to the computer through the Minsk-1560M unit.

The input documents and inquiries are subjected to structural-logical control and then are indexed and recorded on magnetic tape. The indexing of the documents and inquiries is carried out by standard search procedures developed for this purpose which use a negative dictionary, morphological analysis of the words and compressed coding of Russian-language words.

When the subsystem is performing the search procedures, files of relevant documents are organized in response to inquiries. The procedure for documenting these and others which emerge at various stages in the processing of the information and the files amounts to their representation in the required form and output on perforated tape, punchcards, magnetic tape or a printer. The texts of the relevant documents may also be output on teletype or Videoton-340 units.

The running of the IRI subsystem of the MARS NTI on the Minsk-32 consists of performance, using the dispatcher, of the following procedures: organization on magnetic tape of files of documents and their search forms, the retrieval prescriptions of the inquiries, and the files of relevant documents, documentation of the files and processing of statistical data. The average time for input, control and indexing of 100 documents input directly from I/O units into the Minsk-32 is 28 minutes, and from a remote unit (not counting the time for typing in the information) 270 minutes; the time for input and processing of inquiries is 12 and 105 minutes respectively. Identification of 100 documents from a single inquiry requires 1.5 minutes.

The IRI subsystem is oriented toward servicing of up to 4,000 inquiries with a two-week cycle for processing of 3-4 thousand documents. Completeness is 74 percent and accuracy 85 percent.

Including the standard programs from the Minsk-32 software, the total volume of software in the IRI subsystem is about 40,000 instructions.

The IRI subsystem of the MARS NTI was developed and is being operated by UkrNIINTI [Ukrainian Scientific Research Institute of Scientific and Technical Information] of Gosplan, Ukrainian SSR.

Revised version received 6 February 1978.

COPYRIGHT: UkrNIINTI, 1978

8480

CSO: 1870

SYNTHESIS OF MULTICHANNEL RADARS FOR MEASURING THE COORDINATES OF OBJECTS

Kiev IZVESTIYA VUZOV SSSR - RADIOELEKTRONIKA in Russian Vol 21, No 4, Apr 78
pp 5-13

[Article by A. P. Lukoshkin and S. S. Poddubnyy]

[Text] A multichannel radar receiver circuit for angle, range and rate-aided tracking of objects in the presence of external interference and noise generated within the receiver has been synthesized using methods of nonlinear filtering of Markov processes. A block diagram of a synthesized radar indicator is shown and analyzed with various antenna system radiation patterns.

One of the most promising trends in the development of radar technology is multichannel systems whose use makes it possible to obtain solutions to many urgent problems of present-day radar. One of the more important of them is the problem of angle, range and rate-aided tracking in a background of external spatially-correlated anisotropic noise.

The problem of measuring angular coordinates under such conditions has been solved in (1,2) using the maximum probability method for synthesis of the systems. However, the limitations inherent in this method (3,5) have been responsible for the fact that only discriminators which are in many cases impracticable have been synthesized in the studies (1,2). In order to obtain results of a more general type and practical value, the statement of the problem has been broadened in this article to approximate actual conditions. The main focus is on synthesis of a multichannel tracking indicator of the angular coordinates, range and velocity of a tracking target for a radar with a phased antenna array (FAR) using the nonlinear filtration of Markov processes method. The structure of the indicator is considered with different types of receiving antenna beam patterns (DN).

Statement of the Problem

As a rule, coordinates of objects being tracked vary in time in a random manner unknown to the observer in advance, that is they are random processes.

It may be assumed with a large degree of certainty (3,4,5) that the variation processes of the angular coordinates $\alpha(t)$, $\beta(t)$ and range $\tau(t)$ are stationary Gaussian Markov processes. Let us also assume that the energy spectra of these processes are known and coordinates $\alpha(t)$, $\beta(t)$ and $\tau(t)$ themselves have been encoded by nonlinear methods in the pulse signal being received, which is characteristic of most radar systems. It is also known that the system's receiving antenna has M receiving channels, a number greater even if per unit than the number of external localized noise sources.

In order to simplify the computations during synthesis we will consider the signals reflected from the target nonfluctuating and the target localized while the dimensions of the system's receiving antenna and the spectrum width of the sounding pulse are such that signal delay at the receiving antenna aperture may be ignored.

Thus, the position vector of the tracking target $x(t)$ consisting of three subvectors representing the position on each of the measured coordinates is defined by the probability equation

$$\dot{x}(t) = Fx(t) + G\xi(t), \quad (1)$$

where $x(t)$ is the position vector defining

$$x(t) = \begin{pmatrix} x_\alpha(t) \\ x_\beta(t) \\ x_\tau(t) \end{pmatrix}, \quad (2)$$

and $x_\alpha(t)$, $x_\beta(t)$ and $x_\tau(t)$ are the vectors defining the position of the tracking target with respect to azimuth, elevation and range in that order.

To reduce the notations in what follows we will assume that the variation processes of the target angles are unidimensional while the range variation process is two-dimensional. Introduction of a two-dimensional Markov process for range variation is dictated by the added necessity of obtaining information on the velocity of the object being tracked. Expanding the results obtained in processes with a large number of components does not constitute the principal difficulty and may be accomplished easily when necessary. For this reason it is possible to write:

$$\begin{aligned} x_\alpha(t) = x_\alpha(t) = \alpha(t); \quad x_\beta(t) = x_\beta(t) = \beta(t); \\ x_\tau(t) = \begin{pmatrix} x_1(t) \\ x_2(t) \end{pmatrix}; \quad x_1(t) = \tau(t). \end{aligned} \quad (3)$$

Studies (4,5,7,) show that matrixes F and G have a block form and define the filter parameters establishing the variation processes of the angular coordinates and range

$$F = \begin{vmatrix} F_\alpha & 0 & 0 \\ 0 & F_\beta & 0 \\ 0 & 0 & F_\tau \end{vmatrix}; \quad G = \begin{vmatrix} G_\alpha & 0 & 0 \\ 0 & G_\beta & 0 \\ 0 & 0 & G_\tau \end{vmatrix}; \quad (4)$$

$$, F_\alpha = -\psi_\alpha, F_\beta = -\psi_\beta; \quad F_\tau = \begin{vmatrix} -\psi_1 & 1 \\ -\psi_2 & 0 \end{vmatrix}; \quad \xi(t) = \begin{vmatrix} \xi_\alpha \\ \xi_\beta \\ \xi_\tau \end{vmatrix}.$$

The vector of the received signals has the following form for a multichannel radar:

$$r(t) = h[t: x(t)] + Be(t) + n(t), \quad (5)$$

where $h[t: x(t)]$ is the nonlinear transformation of the measured coordinates of the target being tracked in the received signal, the dimension vector being $M \times 1$. Further, in order to reduce the notations, instead of $\alpha(t)$, $\beta(t)$ and $\tau(t)$, we will write α , β , τ , $n(t)$ —dimension vector ($M \times 1$), the components of which are uncorrelated white Gaussian noise, internal noise in the receiver channels. B is the dimension matrix ($M \times K$), the b_{ij} element of which is the directional effect factor (KND) of the i channel on the j source of external noise, $e(t)$ is the dimension vector ($K \times 1$) whose elements are the electrical field intensities induced in the radar receiving antenna by external white noise sources.

The form of the nonlinear transformation for the measured coordinates of the tracking target in the received signal $h[t: x(t)]$ is determined by the type of radar receiving antenna radiation pattern and may be written:

for complex radiation patterns

$$h[t: x(t)] = A_c u[t - \tau] \begin{vmatrix} c_1[\alpha, \beta] \cos[\omega_0(t - \tau) + \Phi(t - \tau) + \varphi_1(\alpha, \beta)] \\ c_2[\alpha, \beta] \cos[\omega_0(t - \tau) + \Phi(t - \tau) + \varphi_2(\alpha, \beta)] \\ \vdots \\ c_M[\alpha, \beta] \cos[\omega_0(t - \tau) + \Phi(t - \tau) + \varphi_M(\alpha, \beta)] \end{vmatrix}; \quad (6)$$

for phased radiation

$$h[t: x(t)] = A_c u[t - \tau] c[\alpha, \beta] \begin{vmatrix} \cos[\omega_0(t - \tau) + \Phi(t - \tau) + \varphi_1(\alpha, \beta)] \\ \cos[\omega_0(t - \tau) + \Phi(t - \tau) + \varphi_2(\alpha, \beta)] \\ \vdots \\ \cos[\omega_0(t - \tau) + \Phi(t - \tau) + \varphi_M(\alpha, \beta)] \end{vmatrix}; \quad (7)$$

for amplitude radiation patterns

$$h[t: x(t)] = A_c u[t - \tau] \cos[\omega_0(t - \tau) + \Phi(t - \tau)] \begin{pmatrix} c_1[\alpha, \beta] \\ c_2[\alpha, \beta] \\ \vdots \\ c_M[\alpha, \beta] \end{pmatrix} \quad (8)$$

Symbols introduced in expressions (6), (7) and (8) include: A_c --the known amplitude of the signal being received; $u[t - \tau]$ and $\phi[t - \tau]$ --functions of amplitude and phase modulation of the sounding signal, a function of the phase modulation characteristic of complex signals but lacking with the use of simple signals; $c_i[\alpha, \beta]$ and $\varphi_i[\alpha, \beta]$ --the amplitude and phased beam patterns of the i receiving channel for the incoming signal from the direction of α and β . The occasional shift of phase resulting from reflection of the sounding signal with a particular signal pattern is constant and equal to zero.

Synthesis of an Indicator for Coordinates

With the given statement of the problem--the Markov type of variation of the coordinates being measured and their nonlinear coding in the received signal--the most expedient method for synthesis is the method developed in (8) of nonlinear filtering of the Markov processes.

Before proceeding directly to the synthesis of the indicator, let us mention that, due to the pulsed nature of the sounding signal modulation, processes α , β and τ are discrete time functions. However, considering that in the majority of actual cases the radar repetition period is much smaller than the correlation time for the variation processes of the tracked target coordinates, the variation process of the range and angular coordinates may be considered continuous time functions.

As (6,7) show, according to the theory of nonlinear filtering of Markov processes, the indicator structure may be determined by the solution of two nonlinear differential matrix estimator and variance equations which have the form (7)

$$\dot{x}^*(t) = Fx^*(t) + V^*(t) D[h[t: x^*(t)]] R^{-1} \{r(t) - h[t: x^*(t)]\}, \quad (9)$$

$$\begin{aligned} \dot{V}^*(t) = & FV^*(t) + V^*(t) F^T + GXG^T + \\ & + V^*(t) D[D[h[t: x^*(t)]] R^{-1} \{r(t) - h[t: x^*(t)]\}] V^*(t), \end{aligned} \quad (10)$$

In (9) and (10) the following symbols are introduced: $x^*(t)$ --the value of the position vector of the tracking target coordinates obtained at the indicator output; $V^*(t)$ --the estimated value of the covariant matrix of error in measuring the tracking target coordinates: $D[.]$ --the Yakob matrix, i , the j element of which is defined as $\frac{\partial h_j[t: x^*(t)]}{\partial x^*i(t)}$ (i is the row number,

j the column number); $h[t:x^*(t)]$ --the signal-tracing generated by the indicator for the estimated values of the position vector components; R^{-1} --the reverse correlative matrix for external and internal noise; X --the scattering matrix of processes $\xi_\alpha(t)$, $\xi_\beta(t)$ and $\xi_\tau(t)$.

To begin with we will examine the structure of the indicator without specifying the type of receiving antenna radiation pattern and then analyze it in more detail for the actual signal patterns in (6), (7) and (8). We will specify that

$$h[t:x(t)] = A_c J(\tau, \alpha, \beta). \quad (11)$$

To solve the estimator and variance equations, we will determine the value of matrix $D[h[t:x^*(t)]]$ to be

$$D[h[t:x^*(t)]] = A_c D[J(\tau^*, \alpha^*, \beta^*)] = A_c \begin{vmatrix} \rho_1 & \rho_2 & \dots & \rho_M \\ \Gamma_1 & \Gamma_2 & \dots & \Gamma_M \\ \varphi_1 & \varphi_2 & \dots & \varphi_M \\ 0 & 0 & \dots & 0 \end{vmatrix} = A_c \begin{vmatrix} \rho^T \\ \Gamma^T \\ \Phi^T \\ 0 \end{vmatrix}. \quad (12)$$

In (12), to reduce the notations, the following symbols are introduced:

$$\rho_i = \frac{\partial J_i(\tau^*, \alpha^*, \beta^*)}{\partial \alpha^*}; \quad \Gamma_i = \frac{\partial J_i(\tau^*, \alpha^*, \beta^*)}{\partial \beta^*}; \quad \varphi_i = \frac{\partial J_i(\tau^*, \alpha^*, \beta^*)}{\partial \tau^*}. \quad (13)$$

Given that $y = r(t) - h[t:x^*(t)]$, it is possible to write:

$$D[h[t:x^*(t)]] R^{-1} y = A_c \begin{vmatrix} \rho^T & R^{-1} & y \\ \Gamma^T & R^{-1} & y \\ \Phi^T & R^{-1} & y \\ 0 & & \end{vmatrix}. \quad (14)$$

Substituting (14) in (9) and multiplying the matrixes, we obtain the estimator equation in a developed form more convenient for constructing a block diagram.

$$\dot{x}^*(t) = Fx^*(t) + A_c V^*(t) \begin{vmatrix} \rho^T & R^{-1} & y \\ \Gamma^T & R^{-1} & y \\ \Phi^T & R^{-1} & y \\ 0 & & \end{vmatrix}. \quad (15)$$

By means of equation (15) a block diagram of the estimator may be constructed without expanding the generation block of the $V^*(t)$ factors. This block diagram is displayed in Figure 1. Since the receiving antenna radiation pattern type was not indicated in (15), the structure in Figure 1 is characteristic for any type of dependence for encoding the angular coordinates during reception of the reflected signal.

Analyzing (14), (15) and the block diagram in Figure 1 makes it apparent that in order to obtain the value of the tracking target coordinates in the background of external anisotropic noise, the indicator must carry out the following operations: generation of the vector signal-tracing $h[t;x^*(t)]$ according to the actual values of the $x^*(t)$ coordinates, subtraction of the signal-tracings vector from the vector of the waves being received $r(t)$, range and rate (PV) filtration of the signals of the difference obtained by filters $p^T R^{-1}$, $r^T R^{-1}$ and $\phi^T R^{-1}$ whose structure and function will be considered, amplification of the signals at the outputs of these filters using amplifiers with gain ratios of A_c , and the subsequent filtering of the signals resulting after amplification to isolate the parameters being measured. The indicator also contains a generator for $V^*(t)$ factors, whose structure is determined from the variance equation (10).

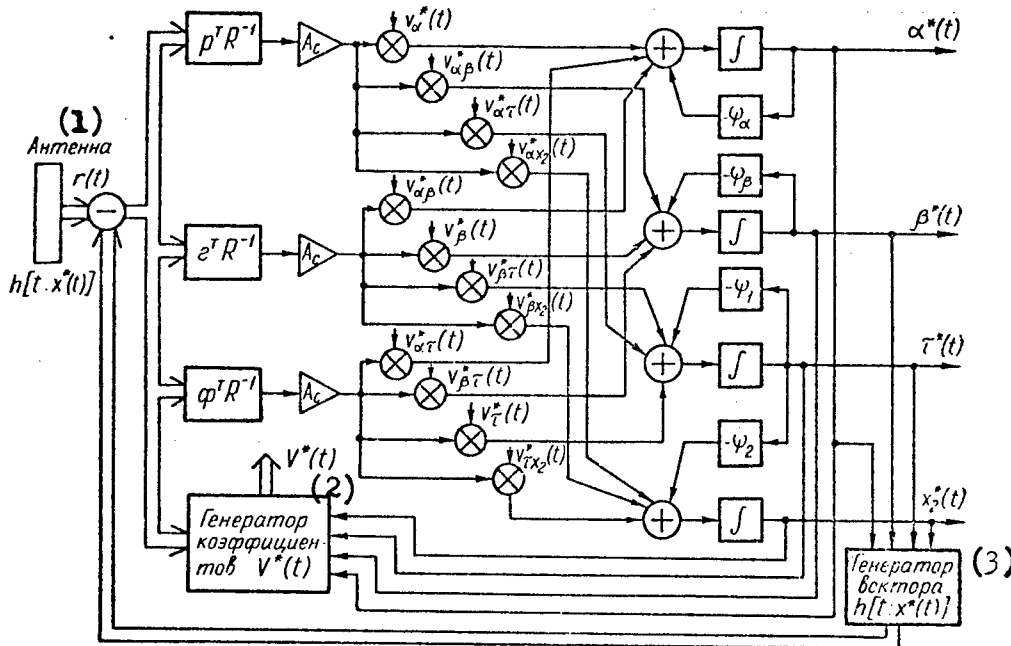

Figure 1. Block diagram of a multichannel radar for measuring coordinates, where $V_{\alpha}^*(t)$, $V_{\alpha\beta}^*(t)$, $V_{\alpha\tau}^*(t)$, $V_{\alpha x_2}^*(t)$, $V_{\beta}^*(t)$, $V_{\beta\tau}^*(t)$, $V_{\beta x_2}^*(t)$, $V_{\tau}^*(t)$ and $V_{x_2}^*$ are the estimated values of the dispersion of error in the measurement of the coordinates (elements of the $V^*(t)$ matrix).

- Key: (1) Antenna
 (2) $V^*(t)$ factor generator
 (3) $h[t;x^*(t)]$ vector generator

To solve the variance equation we write:

$$\begin{aligned}
 D [D [h [t : x^* (t)] R^{-1} y] &= \begin{vmatrix} \frac{\partial p^T R^{-1} y}{\partial \alpha^*} & \frac{\partial r^T R^{-1} y}{\partial \alpha^*} & \frac{\partial \phi^T R^{-1} y}{\partial \alpha^*} \\ \frac{\partial p^T R^{-1} y}{\partial \beta^*} & \frac{\partial r^T R^{-1} y}{\partial \beta^*} & \frac{\partial \phi^T R^{-1} y}{\partial \beta^*} \\ \frac{\partial p^T R^{-1} y}{\partial \tau^*} & \frac{\partial r^T R^{-1} y}{\partial \tau^*} & \frac{\partial \phi^T R^{-1} y}{\partial \tau^*} \\ 0 & 0 & 0 \end{vmatrix} = \\
 &= \begin{vmatrix} A_{11} & A_{12} & A_{13} & 0 \\ A_{21} & A_{22} & A_{23} & 0 \\ A_{31} & A_{32} & A_{33} & 0 \\ 0 & 0 & 0 & 0 \end{vmatrix} = A. \tag{16}
 \end{aligned}$$

Substituting (16) in (10) we obtain the variance equation

$$\dot{V}^*(t) = FV^*(t) + \dot{V}^*(t)F^T + GXG^T + \dot{V}^*(t)AV^*(t). \tag{17}$$

It follows from (17) that to determine the $V^*(t)$ matrix factors, a set of ten nonlinear differential equations must be solved depending on the input of the given $r(t)$'s and the actual values of the tracking target coordinates. In this case the solution of (17) is a function of time and may be obtained by using a computer. To obtain the value of the $V^*(t)$ matrix factors on a computer, signals defined by expression (16) must be inserted.

Analysis of the Indicator for Coordinates with Complex, Phased and Amplitude-Type receiving Antenna Radiation Patterns

We will examine the physical significance of the operations executed by range and rate filters (14) and (16) with complex (6), phased (7) and amplitude (8) type receiving antenna radiation patterns. Here we will cover in more detail the analysis of the range and rate structures of the filters for the received signal as defined in (6) since two of the other cases are peculiar in relationship to them. Implementing (13) for the $h[t:x^*(t)]$ vector defined in (6) --the case of amplitude and phased receiving antenna beam patterns--and introducing the notation $\gamma(\tau^*) = \omega_0(t - \tau^*) + \phi(t - \tau^*)$ and vectors n_α , n_β , n_τ , ξ_α , ξ_β and ξ_τ --dimension $(1 \times M)$, we obtain expressions for the signals at the range and rate filter outputs:

$$\begin{aligned}
 p^T R^{-1} y &= u [t - \tau^*] \cos \gamma(\tau^*) \eta_\alpha R^{-1} y - u [t - \tau^*] \sin \gamma(\tau^*) \zeta_\alpha R^{-1} y; \\
 \eta_{\alpha i} &= \frac{\partial c_i [\alpha^*, \beta^*] \cos \varphi_i (\alpha^*, \beta^*)}{\partial \alpha^*}; \quad \zeta_{\alpha i} = \frac{\partial c_i [\alpha^*, \beta^*] \sin \varphi_i (\alpha^*, \beta^*)}{\partial \alpha^*}; \tag{18}
 \end{aligned}$$

$$\begin{aligned}
 r^T R^{-1} y &= u [t - \tau^*] \cos \gamma(\tau^*) \eta_\beta R^{-1} y - u [t - \tau^*] \sin \gamma(\tau^*) \zeta_\beta R^{-1} y; \\
 \eta_{\beta i} &= \frac{\partial c_i [\alpha^*, \beta^*] \cos \varphi_i (\alpha^*, \beta^*)}{\partial \beta^*}, \quad \zeta_{\beta i} = \frac{\partial c_i [\alpha^*, \beta^*] \sin \varphi_i (\alpha^*, \beta^*)}{\partial \beta^*}; \tag{19}
 \end{aligned}$$

$$\begin{aligned}
\phi^T R^{-1} y = & \left\{ \frac{\partial u [t - \tau^*]}{\partial \tau^*} \cos \gamma (\tau^*) + u [t - \tau^*] \left(\omega_0 + \frac{\partial \Phi (t - \tau^*)}{\partial \tau^*} \right) \sin \gamma (\tau^*) \right\} \eta_{\tau} R^{-1} y - \\
& - \left\{ \frac{\partial u [t - \tau^*]}{\partial \tau^*} \sin \gamma (\tau^*) - u [t - \tau^*] \left(\omega_0 + \frac{\partial \Phi (t - \tau^*)}{\partial \tau^*} \right) \cos \gamma (\tau^*) \right\} \zeta_{\tau} R^{-1} y; \\
\eta_{\tau i} = & c_i [\alpha^*, \beta^*] \cos \varphi_i (\alpha^*, \beta^*), \quad \zeta_{\tau i} = c_i [\alpha^*, \beta^*] \sin \varphi_i (\alpha^*, \beta^*). \quad (20)
\end{aligned}$$

As (18), (19) and (20) indicate, the operations accomplished by the range and rate filters $p^T R^{-1}$, $r^T R^{-1}$ and $\phi^T R^{-1}$ are divided into range filtering and rate filtering. Since the receiving antenna radiation pattern is complex, each of the range and rate filters contains two range filters with rate filters--correlators--located at the outputs. The range filters carry out attenuation and balancing of the external source noise separated according to the angular coordinates from the targets being tracked. Serving as reference vectors for the range filters (18) and (19), values are introduced which are proportional to derivatives from the amplitude and phased receiving antenna beam patterns corresponding to the angular coordinate at the point of its value. This makes it possible to obtain the discriminated characteristics (DX) in the angular coordinates in addition to suppressing external sources of noise at the range filter outputs. Discriminated characteristics are established for angle $\alpha(\beta)$ by the range filters which are a part of the range and rate filter executing the operation (18), (19). The reference vectors of the range filters (20) are defined as the KND [directional effect factors] of the receiving antennas in the pattern at the value of the signal's angular position which permits maximization of the signal to noise ration for the signals arriving from this pattern.

Rate filtering of the outgoing range filter signals is done by the correlators. In the correlators which are a part of the range-rate filters and execute operations (18) and (19), the signal/noise ratio is maximized by feeding in signals-tracings generated according to the actual range value τ^* , that is making allowance for both the time delay and the Doppler frequency shift. At the output of each of the range filters which are part of the range-rate filter (20), correlators are placed into which the derived signal-tracing of τ^* at the point of its value is fed to obtain the discriminated range characteristics.

Since information about τ is isolated from the reflected signal envelope $u[t-\tau]$ and the phase of the high frequency component taking into account the phase modulation of the signal $\phi(t-\tau)$, the operation of these correlators is similar to the operation of a system for automatic range tracking and to an FAPCh [expansion unknown] system. The discriminated range characteristics are obtained by adding the voltages from the outputs of the range-rate filter correlators (20). Thus, with a complex type receiving antenna radiation pattern, the range-rate filters executing operations (18), (19) and (20) contain two range filters and the rate filters and correlators located at their outputs. The structure of the range-rate filters (19) is similar to that in Figure 2, a.

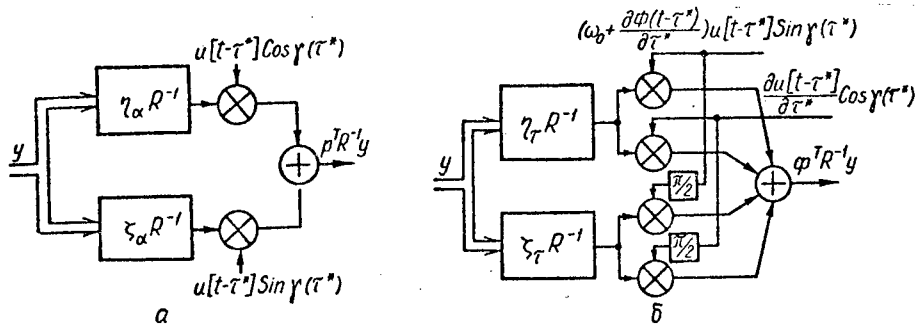

Figure 2. Range-rate filter which performs operations: a-- $\rho^T R^{-1} y$;
 $\delta--\varphi^T R^{-1} y$.

For phased receiving antenna radiation patterns in the system based on (7), we obtain signals at the range-rate filter outputs as follows:

$$\rho^T R^{-1} y = c[\alpha^*, \beta^*] \{ u[t-\tau^*] \sin \gamma(\tau^*) \eta_\alpha R^{-1} y - u[t-\tau^*] \cos \gamma(\tau^*) \zeta_\alpha R^{-1} y \},$$

$$\eta_{\alpha i} = -\frac{\partial \cos \varphi_i(\alpha^*, \beta^*)}{\partial \alpha^*}, \quad \zeta_{\alpha i} = \frac{\partial \sin \varphi_i(\alpha^*, \beta^*)}{\partial \alpha^*},$$

$$\tau^T R^{-1} y = c[\alpha^*, \beta^*] \{ u[t-\tau^*] \sin \gamma(\tau^*) \eta_\beta R^{-1} y - u[t-\tau^*] \cos \gamma(\tau^*) \zeta_\beta R^{-1} y \},$$

$$\eta_{\beta i} = -\frac{\partial \cos \varphi_i(\alpha^*, \beta^*)}{\partial \beta^*}, \quad \zeta_{\beta i} = \frac{\partial \sin \varphi_i(\alpha^*, \beta^*)}{\partial \beta^*},$$

$$\phi^T R^{-1} y = c[\alpha^*, \beta^*] \left\{ \frac{\partial u[t-\tau^*]}{\partial \tau^*} \cos \gamma(\tau^*) + u[t-\tau^*] \left(\omega_0 + \frac{\partial \Phi(t-\tau^*)}{\partial \tau^*} \right) \times \right.$$

$$\left. \times \sin \gamma(\tau^*) \right\} \eta_\tau R^{-1} y - \left[\frac{\partial u[t-\tau^*]}{\partial \tau^*} \sin \gamma(\tau^*) - u[t-\tau^*] \left(\omega_0 + \frac{\partial \Phi(t-\tau^*)}{\partial \tau^*} \right) \times \right. \\ \left. \times \cos \gamma(\tau^*) \right] \zeta_\alpha R^{-1} y \},$$

$$\eta_{\tau i} = \cos \varphi_i(\alpha^*, \beta^*), \quad \zeta_{\tau i} = \sin \varphi_i(\alpha^*, \beta^*).$$

As (21), (22) and (23) indicate, the structure of the range-rate filters phased receiving antenna radiation patterns is almost the same as for amplitude and phase patterns. The difference lies in the establishment of reference vectors for the range filters.

For amplitude type receiving antenna beam patterns, the signal received from the tracking target is given by (8) while the signals at the range-rate filter outputs have the form:

$$p^T R^{-1} y = u [t - \tau^*] \cos \gamma(\tau^*) \eta_{\alpha} R^{-1} y, \quad (24)$$

$$\eta_{\alpha i} = \frac{\partial c_i [\alpha^*, \beta^*]}{\partial \alpha^*},$$

$$r^T R^{-1} y = u [t - \tau^*] \cos \gamma(\tau^*) \eta_{\beta} R^{-1} y, \quad (25)$$

$$\eta_{\beta i} = \frac{\partial c_i [\alpha^*, \beta^*]}{\partial \beta^*},$$

$$\phi^T R^{-1} y = \left\{ \frac{\partial u [t - \tau^*]}{\partial \tau^*} \cos \gamma(\tau^*) + u [t - \tau^*] \left(\omega_0 + \frac{\partial \Phi(t - \tau^*)}{\partial \tau^*} \right) \times \sin \gamma(\tau^*) \right\} \eta_{\tau} R^{-1} y,$$

$$\eta_{\tau i} = c_i [\alpha^*, \beta^*]. \quad (26)$$

It follows from (24), (25) and (26) that a considerable simplification of the range-rate filters results with amplitude receiving antenna beam patterns by comparison to the two preceding cases. This simplification lies in the fact that the range-rate filters contain only one range filter and half as many correlators as for amplitude/phase and phased type receiving antenna beam patterns.

Substitution (18) to (26) in (16), the filter structures may be deduced, the output signals of which are fed into a computer to obtain the values of the scattering matrix $V^*(t)$ elements corresponding to amplitude/phase, phased and amplitude receiving antenna radiation patterns. It may be shown that the output signals of range-rate filters A_{13} , A_{23} and A_{33} in expression (16) are obtained by using elements of the structures of range-rate filters $p^T R^{-1}$, $r^T R^{-1}$ and $\phi^T R^{-1}$. To obtain output signals A_{11} , A_{12} and A_{22} , new range-rate filters whose structure is defined by differentiation of the expressions obtained earlier for the range-rate filter output signals (14) must be inserted into the indicator circuit.

The most straightforward implementation of a variance equation similar to the estimator equation is obtained using amplitude receiving antenna radiation patterns. However, even with amplitude receiving antenna beam patterns, the indicator is complicated enough. Simplification of the indicator with an associated loss of optimum conditions may be done by introducing additional specifications. The requirement for a large signal/noise ratio at the range filter outputs (3,6,7) is one of the main specifications making it possible to determine the scattering matrix $V^*(t)$ factors in a steady-state tracking

operation in advance. For the problem being considered, this specification is met with sufficient angular scattering between the external noise sources and the target being tracked. It should be pointed out that this requirement is ordinarily fulfilled in practice since the signal/noise ratio with small angular scattering of the external noise sources and the tracking target is so small that measuring the target coordinates is impossible (1). Because of this, in a suboptimal version, the value of the scattering matrix $V^*(t)$ for errors may be computed for the worst case, that is for the minimum signal/noise ratio at the output of the range filters with which tracking the target and their use in an indicator structure developed from the estimator equation are still possible. Here, simplifying the circuit is done at the expense of losing its optimum operation for other signal/noise ratios.

Conclusions

It should be mentioned in conclusion that the use of the method for synthesizing an indicator for tracking target coordinates in a background of external anisotropic noise by means of the theory of nonlinear filtering of Markov processes has made it possible to derive the structure of the indicator being implemented rather than the optimum structures obtained in (1). The synthesized indicator is a tracking type indicator and its bandpass in the best way complies with the variation spectra of the evaluated parameters and a signal/noise ratio which increases the accuracy of measuring these parameters. To increase signal/noise ratio in the indicator structure, there are range filters with reference vectors regulated by the value of the angular coordinates which suppress external source noise and rate filters and correlators. In a suboptimal version, there has been considerable success in simplifying the indicator circuit with the variance equation having been solved in advance.

BIBLIOGRAPHY

1. Gavrilin, S. A.; Lukoshkin, A. P.; and Romanov, E. D., "The Synthesis of a Multichannel Angular Discriminator with Dual Frequency Sounding Signal," in the collection "Rasseyaniye i difraktsiya radiolokatsionnykh signalov i ikh informativnost'" [Scattering and Diffraction of Radar Signals and Their Information Content], L., LIAP, No 2, 1976.
2. Leksachenko, V. A.; and Leksachenko, T. A.; "On an Equation for an Adaptive Antenna Array," in the collection "Analogovyye i Tsifrovyye metody obrabotki radiosignalov v sovremennykh radiosistemakh" [Analog and Digital Methods of Processing Radio Signals in Contemporary Radio Systems], under the direction of A. P. Lukoshkin, L., LIAP, No 10.
3. Tikhonov, N. I.; and Kul'man, N. K. "Nelineynaya filtratsiya i kvazikogerentnyy priyem signalov" [Nonlinear Filtration and Quasicoherent Signal Reception], Moscow, SOVETSKOYE RADIO, 1975.

4. Derusso, P.; Roy, R.; and Klouz, C.: "The Range of Conditions in Equation Theory," Moscow, Nauka, 1970.
5. Van Tris, G. "Detection, Estimation and Modulation Theories. 1. Detection, Estimation and Linear Modulation," Moscow, SOVETSKOYE RADIO, 1972.
6. Van Tris, G.: "Detection, Estimation and Modulation Theories, 2. Non-linear Modulation Theories," Moscow, SOVETSKOYE RADIO, 1975.
7. Snayder, D.: "A Method of Equations of State for Continuous Estimation in the Application and Theory of Communications," Moscow, ENERGIYA, 1973.
8. Stratonovich, P. L.: "The Application of the Theory of Markov Processes for Optimum Signal Filtration," RADIOTEKHNIKA I ELEKTRONIKA, 5, No 11, 1960.

COPYRIGHT: Izvestiya vuzov SSSR--Radioelektronika, 1978

8945

CSO: 8144/2479

UDC 621.318:681.327.11

METHODS OF ENGINEERING REALIZATION OF READ OUT DEVICES FOR PLANE MAGNETIC DOMAINS

Moscow PRIBORY I SISTEMY UPRAVLENIYA in Russian No 6, July 78 pp 15-18

[Article by N. P. Vasil'yeva, doctor of engineering science, O. A. Sedykh, candidate of engineering science, and O. M. Fiozhkina, engineer]

[Text] Making use of the controlled movement of plane magnetic domains (PMD) (1) permits construction of highly reliable high-speed digital devices of various capacity and function (2). In particular, PMD memory (ZU) is attractive thanks to its potential possibility of replacing electromechanical storage, at least in the small to medium capacity range. The advantages of PMD memory are short access time, low cost due to the simplicity of the technology of manufacturing magnetic matrices, high reliability, and the capability of transmitting data at various rates.

An important part of PMD devices are the readout sensors that convert bits of information, determined by the presence or absence of PMD at the output section of the channel, into electrical signals.

A number of requirements have been imposed on the read out devices: the magnitude of the output signal sufficient to control semiconductor integrated amplifiers; the small area occupied by the sensor on the substrate; and the compatibility of the sensor and PMD device manufacturing technologies. The latter requirement assumes especially great importance with industrial output. Based on these requirements, we will discuss below sensors using only two of the three known methods for read out of PMD (3)—inductive (ID) and magneto-resistance (GD) sensors; magneto-optical sensors do not meet the requirement for simplicity of technology. Inductive sensors are the easiest to manufacture and they introduce no additional operations in the manufacture of PMD devices as a whole.

Inductive Read Out of PMD

Inductive sensors (fig. 1,a) contain channels -1-, through which the PMD -2- move, and read out loops -3- of plane conductors situated parallel to the surface of the magnetic film directly above the PMD propagation channels.

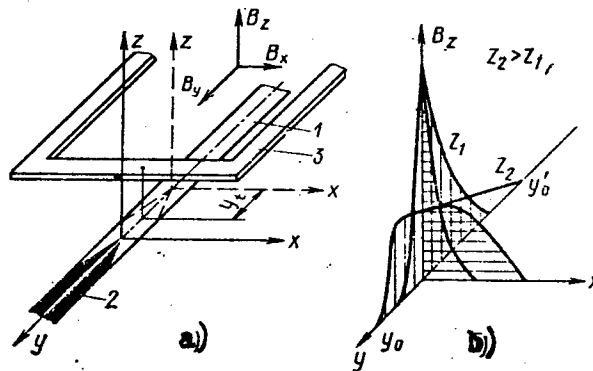

Fig. 1. Inductive sensor: a -- basic structure of the sensor; b -- distribution of the vertical component of the field of dissipation of the PMD tip; z_1, z_2 -- distance between the magnetic film and the loop

The inductive signal source is the field of dissipation of the moving PMD; it is formed from the fields of dissipation of the inclined walls forming the tip of the PMD. The value of the EDS [electromotive force] induced in the loop during passage of the PMD is determined by the flow of dissipation and speed of movement of the PMD. In the coordinate system in fig. 1, a, b, the components of the field of dissipation B_x and B_y do not affect the

signal since they are in the plane parallel to the plane of the loop. Based on the law of electromagnetic induction and on the supposition of the invariability of the field of dissipation of the tip of the PMD during its movement through the channel (in the coordinate system which moves together with the tip), we will obtain the dependence of the instantaneous value of the signal in the loop $\varepsilon(t)$ on the value of the vertical component of the field of dissipation $B_z(y_t)$ in the section of the tip intersecting the loop at the corresponding moment of time t :

$$\varepsilon(t) = 2avB_z(y_t); \quad (1)$$

where v is the velocity of PMD movement, and $2a$ is the width of the channel within which $\partial B_z / \partial y$ we consider invariable.

Accordingly, the maximum value of the signal $\varepsilon_{\max} = 2avB_{z \max}$, where $B_{z \max}$ is the maximum value of the vertical component of the field of dissipation of the PMD, and the duration of the signal $\tau = (y_0 - y'_0 + d)/v$, where d is the width of the loop, and y_0 and y'_0 are the ordinates inside and outside the PMD respectively, for which B_z at the level of the plane of the loop attenuates to zero (see fig. 1, b).

Inasmuch as it was assumed when formula (1) was derived that $\partial B_z / \partial y$ does not depend on coordinate x at the level of the location of the loop within the

width of the channel, and is equal to zero outside the channel, expression (1) may yield a substantially understated value of the signal. When using the spatial distribution of the field of dissipation of the PMD, obtained on the basis of a model of the inclined wall (4) for a channel 50 mkm $\sqrt{\text{microns}}$ in width, distance between the loop and the film of 40 mkm, and PMD movement velocity of 500 m/s $\sqrt{\text{meters per second}}$, by formula (1) we find that $\epsilon_{\max} = 0.01 \text{ mV } \sqrt{\text{millivolt}}$. A signal obtained experimentally in channels up to 100 mkm wide, according to foreign sources (5) and according to data established by the authors of this article, does not exceed 100 mkV $\sqrt{\text{microvolts}}$. Amplifying such low signals requires complex and expensive sense amplifiers. In connection with this, ways of increasing the signal with inductive sensors are being studied: 1) increasing the velocity of the PMD in the readout channel; 2) increasing the number of sense loops and optimizing the design of sense coils; 3) ramification of the sense channel, i.e. increasing the number of tips of the PMD simultaneously intersecting the loop.

Increasing PMD Velocity

According to the literature (6), velocity v of the PMD is determined by the expression

$$v = \gamma_t (H_{np} - H_w - \sigma_w / 2aM_s), \quad (2)$$

where σ_w is the specific energy of the 180° wall of the PMD, H_w is the coercive force of the wall, γ_t is the mobility of the wall, M_s is the magnetization of the film, $2a$ is the channel width, and H_{np} is the magnetic field driving the PMD.

All these parameters, except read out channel width, depend on the material of the film and mode of operation of the entire device. They cannot be changed except in the read out section without considerable technological costs.

The output signal can be increased by expanding the channel in the read out section. However, increasing channel width is expedient up to a specific limit, since in doing so the field of spontaneous nucleation of the PMD decreases.

Sense Inductor

Analysis of the various alternatives in the construction of sense inductors shows the advantages of a single layer multi-loop sense inductor, the loops of which are successively intersected by the moving tip of the PMD. The maximum number of loops w_{\max} of this inductor which makes it possible to increase the overall amplitude of the signal is calculated by the formula

$$w_{\max} = (y_0 - y_0') / (d + d') + 1,$$

where d' is the distance between loops.

Use of a large number of loops increases the duration of signal τ_k from the inductor without increasing its amplitude. The duration of signal τ_k is associated with the parameters of the inductor the following way:

$$\tau_k = \frac{d + d'}{v} (\omega - 1) + \tau.$$

To increase the signal, loop width and distance must be small. Limiting factors are increasing complexity of manufacturing them and the increase in the ID output resistance.

Ramification of FMD in the Readout Area

Increasing the number of tips of the FMD, which intersect the loop simultaneously, increases the signal proportionately. The simplest method of such an increase in the open FMD propulsion channels is suggested in the literature (7); in the process, identical information which is sensed simultaneously is recorded in the several channels intersected by the sense loop. The structure shown in figure 2 (8) is the most efficient for ring registers. It makes use of channel expansion, an increase in the number of loops (not shown in fig. 2), and FMD ramification to several tips; the latter is effected for τ propulsion strokes with width τ_{np} with use of m successive branchers. Output signal U is proportional to the number of FMD tips which intersect the inductor in the sense stroke.

The use of branchers increases the area of the device and reduces its speed. The following expressions have been derived for optimal sensor construction design based on requirements imposed on the output signal, and also for maximum output signal estimates based on permissible sensor sizes:

$$n_1 < \frac{2\tau_{np} v}{h_p}; \quad m > \frac{2}{n_1} (U/\epsilon_w - 1) \quad T = \frac{h_p}{v \tau_{np} \cos \alpha} \left(\frac{U}{\epsilon_w} - 1 \right) +$$

$$+ 1; \quad S = k \frac{2 \cdot 10^2 (2a)^2}{\tau_{np} v} \left(\frac{U}{\epsilon_w} \right)^2; \quad B_c =$$

$$= 2h_p \operatorname{tg} \alpha \left(\frac{U}{\epsilon_w} + N - 2 \right),$$

where h_p is the height of the brancher, S is the total area of all branchers, n_1 is the number of elements of one brancher, α is the angle of their slope relative to the axis of easy magnetization (OLN), k is the coefficient which considers the distance between branchers; B_c is the width of the readout area, N is the number of serviced information channels, and ϵ_w is the output signal at the intersection of the readout inductor by one FMD tip.

Some bulkiness of the branchers is partially atoned for: in view of the fact that the connection of the information circuit to the sensors is a gate (no reverse transmission of the signal from the sensor to the information circuit), several information circuits, selected by the selecting circuit, are connected to a single readout device.

Inasmuch as FMD readout by the inductive method is in principle effected only during its movement, i.e. in the period of action of the fields of propulsion or erasure, it is necessary to examine the conditions under which there is no interference from these fields.

The fields of propulsion and erasure are directed parallel to the plane of the magnetic field and, consequently, to the plane of the sense coil, so that there should be no interference during readout in the ideal case. However, the field of a real coil used to create the control fields has a component perpendicular to the plane of the field, especially if misalignments occur during assembly of the device.

The interference induced to the edges of the control fields is very significant. To reduce it, the substrate with the magnetic matrix must be arranged in a region of a most uniform control field, and the main thing is to separate in time the moments of turn-on and turn-off of the control fields and the moment of intersection of the readout loops by the FMD tips. For this reason, readout must be discontinued in the period of erasure despite the fact that erasure fields with high amplitudinal intensity are used in FMD devices to increase speed and that erasure is a rapid process, being a simultaneous compression of the FMD from all sides. Erasure is practically concluded during erasure field buildup, i.e. the useful signal and the interference are induced into the readout coil practically simultaneously. With readout in the FMD propulsion period, there exists the possibility of designing the geometric parameters of the device so that the time of passage of the FMD tip from the place where it was prior to the propulsion stroke to the readout area exceeds the time for buildup of the drive field pulse.

Number N of serviced channels

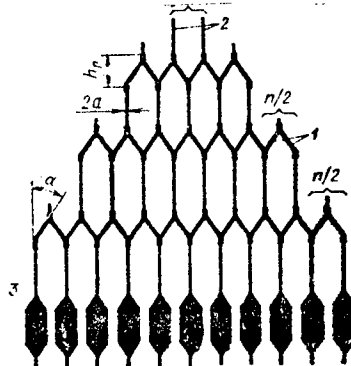

Fig. 2. Structure of an inductive sensor with enhanced sensitivity:
 1 -- elements of brancher; 2 -- information channels;
 3 -- readout channels

To isolate the useful signal of the ID from the interference caused by the edges of the control pulses, a gated readout amplifier is used. Between the first loop of the sense coil and the section of PMD fixation, located directly in front of it, a specific distance h_n is provided that is sufficient for attenuation, during time τ_n of its passage by the FMD tip, of the interference induced into the sense coil by the leading edges of the control pulses: $h_n > \tau_n v$.

The gated amplifier parameters are selected accordingly: the lag time of the strobe pulse t_3 and its width t_{strobe} must meet the following relationships:

$$t_3 > h_n/v_{\text{max}}; t_{\text{strobe}} \geq \tau_k + h_n/v_{\text{min}} - h_n/v_{\text{max}}; t_3 + t_{\text{strobe}} < \tau_{\text{np}},$$

where v_{max} and v_{min} are the maximum and minimum speed, respectively, of the PMD in the operating range of the control fields.

The expressions derived make it possible to design an ID (and readout amplifier for it) based on the requirements for the output signal, as well as to estimate the maximum output signal, based on the prescribed dimensions of the ID and the speed of the readout circuit. For example, with a detector area of 60 mm^2 , and film material of NiFeCo with ratio of components 63:12:25, and propulsion field of 480 A/m in the readout area, branched into 19 channels with a width of 450 mkm , with a six-looped coil, a signal of 6 mV has been obtained experimentally; ramification and readout of the PMD were effected during three propulsion strokes. The induction signal obtained directly from the sense coil equals 6 mV . The photo masks for manufacture of a magnetic matrix and the leads to it are shown in figure 3, a and b, respectively. The inductive sensor is manufactured simultaneously with the entire PMD device; the branchers and readout section are made together with the PMD propagation channels and are a branch off of them, while the sense coil is made together with the stop lines (conductors that create local magnetic fields for stopping the PMD in the propagation process).

Fig. 3. Photo masks for manufacture of magnetic matrix (a) and leads to it (b)

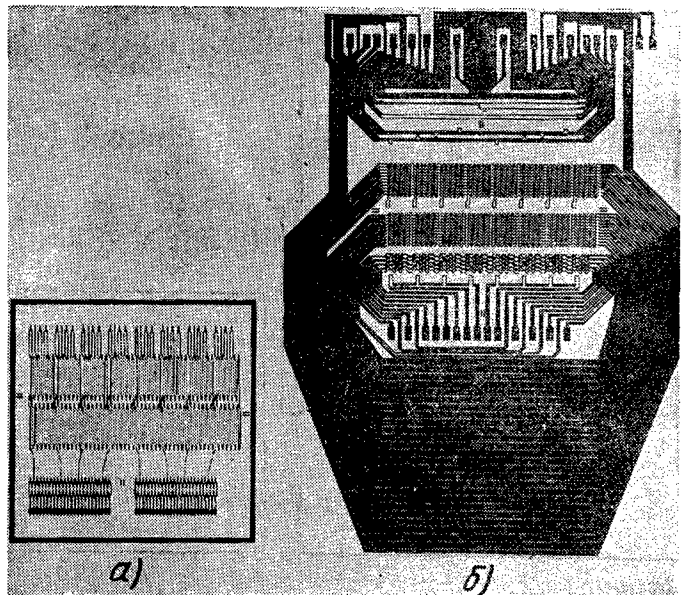

Thus, ID--these are simple and reliable sensing devices, but they do have shortcomings: speed is reduced and the readout area increases as the output signal increases.

Magneto-Resistance Readout of PMD

The requirement for small area occupied by the sensor comes to the foreground with the growth in the density of the information, particularly if it is necessary to organize readout with parallel selection. This requirement is satisfied by the GD based on the use of the classical and planar Hall effect and the effect of magneto-resistance. The field of dissipation of the PMD and its intensity of magnetization can be used for readout. In the latter case, sensors are used that operate on the magneto-resistance effect and the Hall planar effect in magnetic film (9). Magneto-resistor sensors (MRD) are preferred over Hall planar effect sensors because they have two contacts, and not four. The principle of operation of the MRD is based on the dependence of its resistance on the mutual arrangement of the vectors of magnetization and measuring current.

The intensity E_x of an electric field in a ferromagnetic film, caused by the magneto-resistance effect, is described by the phenomenological expression (10)

$$E_x = j (\rho_{\parallel} \cos^2 \varphi + \rho_{\perp} \sin^2 \varphi), \quad (3)$$

where j is the current density, ρ_{\parallel} and ρ_{\perp} are the specific resistances of the film with the magnetization vector \mathbf{M} , respectively parallel and perpendicular to the current vector, and φ is the angle between the directions of the current and the magnetization vector.

The MRD resistance is minimal when the magnetization vector is perpendicular to the direction of the measuring current, and maximum when the magnetization vector is parallel to the latter (10). Inasmuch as the magneto-resistor effect is invariant relative to magnetization vector rotation by 180° , it is necessary to provide deviation of the PMD magnetization from the OLN in one of its states (for example, in the "1" state) by an angle as close to 90° as possible. This effect is achieved by using the anisotropy of the form of the channel in the readout area (9) or an additional external field.

Use of the anisotropy of the form of the channel is suggested in the literature (9) (fig. 4). Let in a "0" state (absence of a PMD) magnetization vector \mathbf{M}_1 be directed upwards along the OLN, in a "1" state (presence of a PMD) due to the continuity of the normal component of the magnetization vector at the border of the two media (channel and film mass) vector \mathbf{M}_2 be directed at an angle of 2β to the OLN (β is the angle between the OLN and the axis of the inclined section of the channel), and at sufficient distance from the side walls of the channel vector \mathbf{M} be parallel to the OLN and be directed downwards in the case. Then, for the magnetization vector

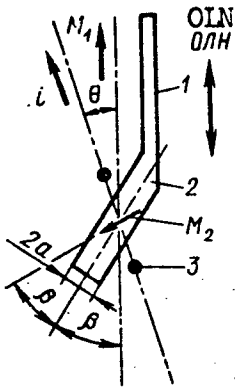

Fig. 4. Magneto-resistor sensor in a PMD propagation channel: 1 -- channel, 2 -- readout area, 3 -- contact pads

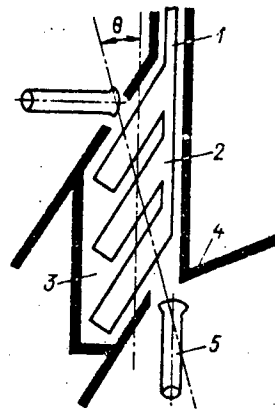

Fig. 5. Magneto-resistor sensor with enhanced sensitivity using the anisotropy of the form of the channel: 1 -- channel, 2 -- readout area, 3 -- high-coercive mass, 4 -- insulating gap, 5 -- contact conductors

in the entire inclined section to be an angle 2β with the OLN, the anisotropy of the form of the channel must prevail over the uniaxial anisotropy, i.e.

$$4\pi M_s (\delta/2a) \gg H_k, \quad (4)$$

where M_s is the magnetization of saturation, H_k is the field of anisotropy, and δ is the film thickness.

The channel width must be sufficiently small to fulfill condition (4). If, however, the channel width does not satisfy condition (4), the mean angle between the axis of the channel and the magnetization will be $\beta' < \beta$.

The MRD sensitivity (ratio of output signal to measuring current) is equal to the difference of its resistances in the "1" and "0" states. Let us replace the area, occupied by the sensor, by a rectangle that has an effective width b equal to the width of the contact pads, and an effective length l equal to $2a/\sin(\theta + \beta)$. Then on the basis of expression (3), let us write

$$\Delta R = G_1 \frac{(P_{\parallel} - P_{\perp})}{b\delta} \frac{\cos^2 \theta - \cos^2(\theta + \beta + \beta')}{\sin(\theta + \beta)}, \quad (5)$$

where θ is the angle between the axis of the contacts and the OLN, G_1 is the coefficient which depends on the form of the contacts and on the resistance of the sections of magnetic film connected in parallel and in series with the MRD.

From formula (5) we have derived the relation between the optimal θ_{opt} angle $\theta = \theta_{opt}$ and the angles β and β' : $\sin(\theta_{opt} + 2\beta + \beta') = 3\sin(\theta_{opt} + \beta')$.

The optimal value of angle β based on the condition of maximum sensitivity while preserving the stability of the FMD in the inclined channel and the relationship (4) is about 30° . The angle β' varies from $-\beta$ to $+\beta$, increasing with channel width reduction. For example, experiments show that for 72:15:13 NiFeCo film with a channel width of 100-150 mkm, the angle β' is close to zero and $\theta_{opt} = 15 - 20^\circ$. MRD sensitivity in this case is about $1,5G_1a(\rho_{||} - \rho_{\perp})/b\delta$.

From formula (5) it is evident that MRD sensitivity is proportional to channel width. However, meeting condition (4) requires a small channel width. Consequently, a MRD in a nonbranching channel does not permit raising sensitivity.

Two types of MRD have been suggested by the authors: using the anisotropy of the form of the channel (11) and using an external field (12).

To increase detector sensitivity while meeting condition (4), a comb-shaped sensor with parallel branches has been created (1) (fig. 5). The width of each branch is so small that the anisotropy of the form prevails over the uniaxial anisotropy, and the magnetization vector when a FMD is present in the sensor is directed at an angle of 2β to the OLN. The effective length of the sensor is equal to ln_2 , where l is the effective length of one branch, and n_2 is the number of MRD branches. Experiments by the authors show that $\Delta R = 6 \text{ mV/A}$ (13) for 72:15:13 NiFeCo film with $\rho = 26 \text{ m}\Omega\cdot\text{cm}$, $\Delta\rho/\rho = 0.8\%$, $\beta = 30^\circ$, $\theta = 15^\circ$, $n_2 = 6$, $2a = 50 \text{ mkm}$, while as per the structure shown in fig. 4 with $\Delta\rho/\rho = 1.5\%$ and $2a = 120 \text{ mkm}$, $\Delta R = 3 \text{ mV/A}$ (9).

Fig. 6 shows another type of MRD. In this case, an external control field H_1 perpendicular to the OLN (12) is used instead of the anisotropy of the form to rotate the magnetization vector to the optimum angle to the current direction when a FMD is in the channel.

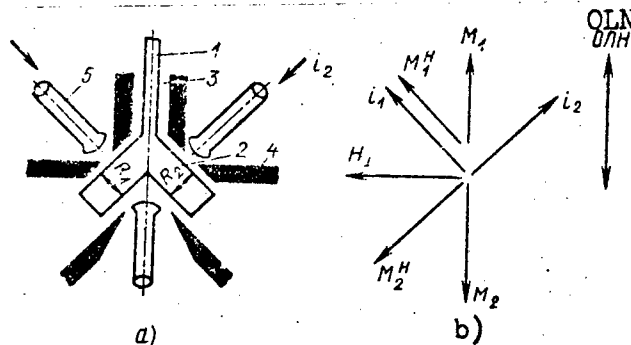

Fig. 6. Magneto-resistor sensor with enhanced sensitivity using an external magnetic field: a -- sensor structure, b -- relative arrangement of direction of measuring current and magnetization vector with or without the control field; 1 - 5, same as for fig. 5

Let the bridge be supplied from current source I , then its output $[out]$ voltage equals $U_{out} = I (R_1 R_2 - R_3 R_4) / (R_1 + R_2 + R_3 + R_4)$.

If $R_1 = R_L$, $R_3 = R_T$, and $R_2 = R_4 = R$ (such a selection is feasible with respect to the symmetry of the arms of the bridge), then $U_{out} = IR (R_L - R_T) / (2R + R_L + R_T)$.

Inasmuch as $R_n = R_0 (1 + \gamma \cos 2\varphi_n)$, $R_{\bar{n}} = R_0 (1 + \gamma \cos 2\varphi_{\bar{n}})$, $\varphi_{\bar{n}} = \varphi_n - 90^\circ$, then $R_n + R_{\bar{n}} = 2R_0$, $R_n - R_{\bar{n}} = 2\gamma R_0 \cos 2\varphi_n$.

Hence $U_{out} = I \gamma R_0 R \cos 2\varphi_n / (R + R_0)$.

It follows from this expression and the table that the output voltage equals 0 when $\varphi_r = \pi/4 + k\pi$, is maximum when $\varphi_r = k\pi$, and is minimum when $\varphi_r = k\pi + \pi/2$.

The advantage of this MRD scheme over the preceding one is that it is possible to optimize the form of the sensor and the angle of rotation of the magnetization independently of each other and to obtain greater MRD sensitivity in an equal area taken up by the sensor. Its shortcoming is the necessity of a source of field H_{\perp} , therefore it is feasible to apply this scheme in those FMD devices for the functioning of which such a source is needed (5, 14).

MRD manufacturing technology is more complicated than that for the ID, since additional operations of photolithography of the insulating gap separating the MRD from the film mass, and the manufacture of contacts are required. To simplify the technology, the MRD contact pads must be made as sections of the high-coercive film mass separated by insulating gaps (13). The contact conductors of the sense circuit should be connected by a method that does not cause general heating of the substrate, for example by ultrasonic microwelding. The photomask for manufacture of various types of MRD is shown in fig. 7, a; an experimental model of substrate with MRD is shown in fig. 7, b.

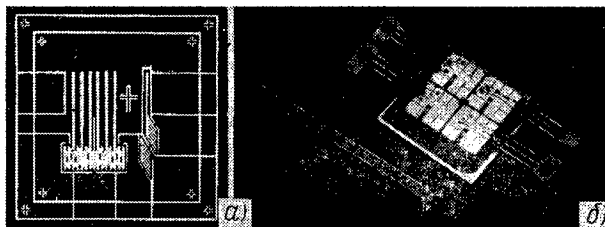

Fig. 7. Photomasks for manufacture of various types of MRD (a) and the external view of the substrate (experimental model) with various types of MRD (b)

The form of the sensor and the configuration of the insulating gaps in the film which divide the MRD from the high-coercive mass are such that the sense current is directed at an angle of 45° to the OLN both in the right, as well as in the left part of it, and the angle between the current senses in the left i_1 and the right i_2 parts of the MRD is close to 90° . From what has been said, it follows that resistance R_M of the MRD can be calculated by the formula $R_M = R_0(1 + \gamma \cos 2\varphi)$,

$$\text{where } \gamma = \frac{\rho_{\parallel} - \rho_{\perp}}{\rho_{\parallel} + \rho_{\perp}}; R_0 = G_2 \frac{\rho_{\parallel} + \rho_{\perp}}{2};$$

and G_2 is the coefficient dependent on the form of the MRD (for a rectangular MRD, $G_2 = l/b\delta$).

It is evident from fig. 6 that when $H_{\perp} = 0$, with or without a "one" PMD in the sensor, the angle between the current sense and the magnetization vector (M_1 and M_2 respectively) in absolute value is equal to 45 or 135° , which corresponds to the equality of the resistances of the right and left parts of the MRD.

The value of angle φ is changed with the deviation of the magnetization vector by the external field, and the direction of its change depends upon whether or not a one PMD was registered in the sensor.

The table below shows the values of the resistances of the right R_r and left R_l parts of the MRD with the presence of a ("1") and the absence of a ("0") PMD for the ideal case when under the effect of the component of the external field H_{\perp} , perpendicular to the OLN, the magnetization vector is turned exactly to 45° from its initial position (vectors M_1^H and M_2^H in fig. 6).

State Состояние ПМД of PMD	Поле Field							
	+ H_{\perp}				- H_{\perp}			
1	φ_{nr}	R_{nr}	φ_{nl}	R_{nl}	φ_{nr}	R_{nr}	φ_{nl}	R_{nl}
		-90°	R_{\min}	180°	R_{\max}	0	R_{\max}	90°
0	0	R_{\max}	-90°	R_{\min}	90°	R_{\min}	0	R_{\max}

Legend: φ_r and φ_l are the angles between the magnetization vector and the current direction of the right and left parts of the MRD respectively.

The "antiphased" change of the resistance of the right and left parts of the MRD made it possible to include them in the adjacent arms of the sense bridge.

Conclusion

Inductive and magneto-resistor PMD sensors are comparatively simple devices which make it possible to obtain an output signal acceptable for joining PMD devices to semiconductor integrated circuits. With an equal area, the MRD has greater sensitivity, however, the ID manufacturing technology is simpler than that for the MRD. This advantage of the ID is currently of decisive importance.

Literature

1. "Prospects for Application of Magnetic Films with Controlled Movement of Domains in Computer Equipment," (Theme Selection), PRIBORY I SISTEMY UPRAVLENIYA, 1973, No 6.
2. "Mobile Magnetic Domain Memory," ELEKTRONIKA, 1975, No 6.
3. Fioshkina, O. M. "Methods of Readout of Information in Thin Magnetic Film Devices, Based on Controlled Movement of Domains," in the book, "Tekhnicheskiye sredstva upravleniya i voprosy ikh nadezhnosti" [Technical Means of Control and Questions of their Reliability], Moscow, Nauka, 1974.
4. Semenov, V. S. "Energy of Domain Walls of Arbitrary Orientation," in the book, "Tez. dokl. XV Vses. soveshch. 'Magnitnyye elementy avtomatiki i vychislitel'noy tekhniki'" [Theses of Reports of the 15th All-Union Conference "Magnetic Elements of Automation and Computer Technology"], Moscow, Nauka, 1976.
5. Spain, R., and Marino, M. IEEE TRANS. ON MAGN., 1970, Vol MAG-6, No 3, pp 451-463.
6. Spain, R. J., and Jauvtis, H. I. JOURN. APPL. PHYS., 1966, Vol 37, No 7, p 2585.
7. Patent FRG No 2438204, 1974.
8. Spain, R. J.; Jauvtis, H. I.; and Duben, F. T. AFIPS CONFERENCE PROCEEDINGS, 1974, Vol 43.
9. Spain, R. J.; Janotis, H. T.; and Franklin, D. H. IEEE TRANS. ON MAGN., 1971, Vol MAG-7, No 9.
10. Vu Din' Ky "Plane Magneto-Resistance Effect in Thin Ferromagnetic Films," IZV. AN SSSR. SERIYA FIZICH., 1965, Vol 39, No 4.
11. Sedykh, O. A.; Vasil'yeva, N. P.; and Fioshkina, O. M. "Magneto-Resistance Device for Readout of Plane Magnetic Domains," Inventor's Certificate No 532130, BYULLETEN' IZOBRETIY, 1976, No 38.
12. Vasil'yeva, N. P.; Sedykh, O. A.; and Fioshkina, O. M. "Magneto-Resistance Device for Readout of Plane Magnetic Domains," Inventor's Certificate No 533982, BYULLETEN' IZOBRETIY, 1976, No 40.

13. Fioshkina, G. M. "Magneto-Resistance Devices for Readout of Plane Magnetic Domains," in the book, "Tez. dokl. XV vses. soveshch. 'Magnitnyye elementy avtomatiki i vychislitel'noy tekhniki'," Moscow, Nauka, 1976.
14. Ponkin, Yu. K., and Ramus, L. T. "Program Time Device with Plane Magnetic Domains," in the book, "Tez. dokl. XV vses. soveshch. 'Magnitnyye elementy avtomatiki i vychislitel'noy tekhniki'," Moscow, Nauka, 1976.

COPYRIGHT: Izdatel'stvo "Mashinostroyeniye"
"Pribory i sistemy upravleniya," 1978

8545
CSO: 1870

SCIENTISTS AND SCIENTIFIC ORGANIZATIONS

BIOGRAPHY OF AZERBAJDZHAN SCIENTIST ABDULLAYEV

Baku BAKINSKIY RABOCHIY in Russian 20 Aug 78 p 3

[Article by Academician A. Prokhorov, Hero of Socialist Labor, Lenin Prize Laureate, Noble Prize Laureate, Academician-Secretary of the Department of General Physics and Astronomy of the Academy of Sciences USSR, Academician B. Vul, Hero of Socialist Labor, Lenin Prize Laureate, Chairman of the Scientific Council on the Problem "Physics and Chemistry of Semiconductors" and Academician M. Topchibashev of the Academy of Medical Sciences USSR, A.S. Azerbaydzhani SSS and AS of the Peoples' Republic of Bulgaria, Hero of Socialist Labor, Vice-president of the AS Azerbaydzhani SSR: "The Inexhaustible Fire of Creativity"]

[Text] Gasan Mamed Bagir Abdullayev commemorates his 60th birthday today. His life's work has been closely associated with the Academy of Sciences of the Azerbaydzhani SSR. This life's work led from the post of laboratory assistant to academician, director of a major scientific center of the republic and not only determined the basic scientific trend of the Azerbaydzhani School of Physics created by him but also engendered foci of development of completely new (for the republic) sectors of industry.

G.B. Abdullayev gained widespread recognition in the Soviet Union and abroad primarily as a result of his fundamental studies in the area of the physics of semiconductors and the development of new semiconductor transformers. Analysis of the first works of Gasan Bagirovich shows that a profound scientific intuition and insight, creative imagination and unusually wide range of interests were the main factors which determined the success of his scientific research.

The first summarizing scientific study by G.B. Abdullayev (his candidate's dissertation, 1948) involved a study of contact phenomena at the interface of different metals and semiconductors. New questions facing the young scientist led him, in 1950, to the famous Leningrad Physics-Technical Institute where, under the direction of Academician A.F. Ioffe, a widely known school of Soviet physicists, was gathered. At this institute Gasan Bagirovich conducted research on the physics of selenium diodes which were, at that time, the only solid-state rectifiers. He was the first to

establish that the physical nature of the processes in these diodes was caused by the formation in them, as they now say, of a heterostructure. The original results obtained provided the basis for his doctoral dissertation, defended by G.B. Abdullayev in Leningrad in 1954. The ideas presented in it were used later by Gasan Bagirovich and his students for an explanation of the performance of selenoid photoelements and also developed by his followers at the Physico-Technical Institute imeni A.F. Ioffe.

We must emphasize that the Leningrad period of G.B. Abdullayev's creative work was of decisive importance in his scientific life. The love for element 34 of Mendeleev's table (selenium) engendered here became a total fascination. Thanks to its unique properties, selenium always remained at the center of the intent attention of the scientist and also determined, afterwards, the scientific fate of many of his students. In Leningrad Gasan Bagirovich was molded and established as an eminent physicist and as one of the leading Soviet scientists in the area of the physics of semiconductors.

In 1955, G.B. Abdullayev's scientific contributions were noted by his becoming a corresponding member of the AS Az SSR and, in 1957, he headed the Institute of Physics and Mathematics of the Academy of Sciences. He has been director of the Institute of Physics of the AS AzSSR since 1959.

Precisely, at this time, there was crystallized the general trend and there was established the purposeful scientific theme of the institute, that is, the concentration of basic forces for the solution of vital problems of semiconductor science and technology, the expansion of the scientific-experimental base and the creation of a school of physics. Within a short time the Institute of Physics acquired a reputation as one of the leading scientific centers of the Soviet Union thanks to the works of Gasan Bagirovich and his associates in the area of production of crystals of selenium and tellurium and complex compounds of them and to the study of their physical properties and the creation of new semiconductor transformers. The fact of the confirmation of the Institute of Physics in 1957, by decree of the Central Committee CPSU and the Council of Ministers, as the country's leading institute in the study of selenium and the development of devices based on it is eloquent testimony of this.

At the same time, under the direct supervision of G.B. Abdullayev, there was deployed research in areas far removed from his own personal scientific interests. With a great sense of perspective, he supports theoretical studies of the physics of a solid and elementary particles. They are successfully conducting, at the institute, studies in such sections as radiophysics, electrophysics, molecular physics and others.

Studies of selenium and diode structures based on it, carried out by Gasan Bagirovich and his students revealed the nature of many physical processes proceeding in them and led to the creation of new, highly-efficient technologies of preparation of selenoid devices of different functional designations.

The complex of scientific-research and experimental design studies conducted by the institute in collaboration with enterprises of the Ministry of the Electronics Industry of the USSR led to the creation in the country of a major specialized sector of the industry for the production of high-purity selenium, new high-efficiency selenium transformers and dozens of devices based on them. The quality of these devices and apparatus measures up to the level of the highest world standards and many of them have been awarded the government Badge of Quality of the USSR. Selenium devices now serve effectively in all domestic radio and television apparatus and constitute the heart of powerful industrial rectifiers.

The development of new semiconductor materials with predetermined properties is one of the main scientific trends being developed successfully by G.B. Abdullayev. In the middle of the 1960's he placed on the agenda, for the first time in our country, the problem of the production and comprehensive study of complex structural analogs of anisotropic elementary semiconductors. The cycle of fundamental studies by Gasan Bagirovich and his works in the study of the optical properties and the energy structure of binary compounds of elements of the 3d and 6th groups greatly expanded the possibilities of semiconductor electronics. In particular, it was established that gallium selenide crystals significantly surpass other non-linear crystals in the infra-red region in respect to many parameters and show promise for use in quantum electronics, non-linear optics and the development of generators with tunable frequency of emission.

These semiconductor compounds also were found to be extremely effective for developing memory elements ("brain cells") of modern electronic computers. Controlled by an electric field, they permit accumulation of information, long-term storage of it and re-recording on the basis of the switching effect. The new micro-devices are superior to existing magnetic memory elements in that their switch over time is three times as fast and this greatly increases the speed of response. There are now underway experimental-design studies on the development of stores for 4th generation EVM [electronic computers] and for the widespread use of them in automatics, telemechanics and radio engineering.

In recent years, G.B. Abdullayev and his associates predicted and produced a large number of new complex semiconductors -- ternary compounds. Now the prospects of their practical use as receivers in the visible and infra-red region or as effective detectors of X-ray and neutron radiations have been demonstrated.

A characteristic peculiarity of G.B. Abdullayev's work in the area of the physics of semiconductors always was their close connection with problems of the development of modern technology.

The above enumerated studies concerning the development and introduction of some special semiconductor devices are only part of G.B. Abdullayev's vast activity for the creation of a modern scientific-experimental and industrial base for their production.

His outstanding scientific achievements and vast organizational work brought G.B. Abdullayev wide acclaim and, in 1967, he became an active member and, in 1970, president of the AS AzSSR. In 1974, he was named Honored Scientist of the AzSSR.

In the late 1960's, G.B. Abdullayev began a completely new aspect of his study of selenium. Even in 1952, he was the first in the world to call attention to the fact that the spectral sensitivity of selenium, astonishingly, completely coincides with the spectral sensitivity of the human eye. At that time, he could only assume the participation of selenium in the transformation of light energy into the energy of the electric potential of the retina. Accumulated factual material permitted him to proceed toward solution of a vital problem (the establishment of the effect of selenium on biological objects) and to unite, for this purpose, the efforts of physicists, chemists and neurophysiologists. Radio-isotopic and other methods were used to study the distribution of selenium in biological objects and its role in enzymic processes and in the increase of light sensitivity of the optic analyzer.

We are singling out here the series of studies by G.B. Abdullayev and his students in the explanation of the participation of selenium in the sight process. The scientific significance of these studies consists of the fact that they contribute considerably to the existing idea concerning the primary mechanism of transformation of light energy into nervous excitation of the retina. In addition to this, they opened new possibilities in the diagnosis and search for therapeutic means during some pathological states of the retina associated with losses of visual acuity and caused, evidently, by a selenium deficit in the retina.

In 1972, G.B. Abdullayev and a group of his students were awarded the state prizes of the Az SSR for research concerning production of new, complex semiconductor compounds, the study of their properties and the development of different transformers based on them and also for research concerning determination of the role of selenium in the sight process.

G.B. Abdullayev's name is associated with the enhancement of the role of the Academy of Sciences as a center of theoretical research and a coordinator of all scientific work in the republic.

G.B. Abdullayev gives great attention to the development of related trends in the basic sciences such as electrochemistry, biochemistry, biophysics, molecular biology and others.

Thanks to the infatigable persistent work of G.B. Abdullayev, there was a radical change toward problems of the practical introduction of new scientific ideas at institutions of the Academy of Sciences.

On the way to solving this problem, there was created a whole series of presently independent scientific and scientific industrial organizations: the Sector of Radiation Research, the SKB [Central Design Bureau] of the Institute of Physics with an experimental plant, a branch of the Institute of Applied Physics, SKB of Biological Instrument Manufacture and others. Their research and technical and industrial potential are directed toward the solution of vital problems of science and technology.

G.B. Abdullayev and his students played a significant role in the development of new, for the republic, non-metal containing sectors of industry such as micro-electronics and instrument manufacture.

Students of G.B. Abdullayev's school make up the basis of the scientific and technical personnel of these sectors and many of his students occupy many key posts.

G.B. Abdullayev also gave much effort and attention to the rearing of scientific personnel in physics and to the spread of knowledge of physics in the republic. As early as 1956, he provided the initiative for and participated in the creation of one of the country's first Chair of the Physics of Semiconductors at Azerbaydzhan State University. He understood well that the success of a scientific institution depends completely on the creative qualities of its collective. Therefore, as early as the beginning of the 1950's, G.B. Abdullayev initiated the inclusion of special courses in the university program and the creation of groups for the "physics of semiconductors" specialty. In order to attract capable young persons to science and to kindle in them a true interest in physics, he wrote popular articles and books and organized a seminar on the physics of semiconductors. The work begun more than 20 years ago, involving the gathering of only a few physicists in a weekly physics seminar, has now become a townspeople's seminar known as "Abdullayev's Seminar," where discussions are held on new ideas, results and also the latest achievements of world science and speeches are presented by Soviet and foreign scientists. G.B. Abdullayev's speeches on scientific and philosophical problems of physics always create great interest. This seminar is of special significance for rearing young scientists and graduate students. Almost all physicists of the republic have been "hardened and annealed" at this seminar.

Scientist-Communist G.B. Abdullayev conducts important public and political work. He is a member of the Central Committee of the Communist Party of Azerbaydzhan, a passionate propagandist of decisions of the Party and the government and a persistent organizer of measures for their fulfillment.

As deputy of the Supreme Soviet USSR, he frequently appears before electors of the towns of Sheki and Vartashen where, as in Nakhichevan, he provided the initiative for the creation and successful development of the scientific base of the AS AzSSR.

G.B. Abdullayev is a member of the scientific council on the complex problem "Physics and Chemistry of Semiconductors" at the Presidium of the AS USSR, chairman of the board of the republican society "Znaniye." He carries on important work at the post of chairman of the Committee on State Prizes of the Azerbaydzhan SSR in the area of science and technology.

He has written 10 monographs and many studies published in the Soviet Union and abroad. He is the author of 50 inventions.

G.B. Abdullayev is an eminent statesman. All who know him are startled by his phenomenal memory, his astonishing efficiency, purposefulness and selfless service in every matter. Whoever turns to him in regard to scientific or personal difficulties always is met with goodwill and receives real assistance or valuable advice. Appearances by G.B. Abdullayev at sessions of a physics seminar, departments and the Presidium of the AS AzSSR are impressive due to his ardentness and deep interest in a successful solution of problems. He does not distinguish problems as being major or secondary; nothing escapes his fixed attention. He frequently is able to find an unexpected solution to a problem. Persons are attracted by his diversity of interests. He is an excellent judge of poetry and music and loves nature.

Gasan Bagirovich Abdullayev greets his jubilee in the bloom of creative forces and with completely new thoughts and ideas.

For his many services to the development of Soviet Science and the training of scientific personnel and in commemoration of his 60th birthday, Gasan Mamed Abdullayev was awarded the Order of Lenin, by Decree of the Presidium of the Supreme Soviet of the USSR.

