

JPRS 70389

28 December 1977

TRANSLATIONS ON TELECOMMUNICATIONS POLICY,
RESEARCH AND DEVELOPMENT

No. 25

DISTRIBUTION STATEMENT A
Approved for Public Release
Distribution Unlimited

20000328 135

U. S. JOINT PUBLICATIONS RESEARCH SERVICE

Reproduced From
Best Available Copy

REPRODUCED BY
NATIONAL TECHNICAL
INFORMATION SERVICE
U. S. DEPARTMENT OF COMMERCE
SPRINGFIELD, VA. 22161

WORLD

WIDE

NOTE

JPRS publications contain information primarily from foreign newspapers, periodicals and books, but also from news agency transmissions and broadcasts. Materials from foreign-language sources are translated; those from English-language sources are transcribed or reprinted, with the original phrasing and other characteristics retained.

Headlines, editorial reports, and material enclosed in brackets [] are supplied by JPRS. Processing indicators such as [Text] or [Excerpt] in the first line of each item, or following the last line of a brief, indicate how the original information was processed. Where no processing indicator is given, the information was summarized or extracted.

Unfamiliar names rendered phonetically or transliterated are enclosed in parentheses. Words or names preceded by a question mark and enclosed in parentheses were not clear in the original but have been supplied as appropriate in context. Other unattributed parenthetical notes within the body of an item originate with the source. Times within items are as given by source.

The contents of this publication in no way represent the policies, views or attitudes of the U.S. Government.

PROCUREMENT OF PUBLICATIONS

JPRS publications may be ordered from the National Technical Information Service, Springfield, Virginia 22151. In ordering, it is recommended that the JPRS number, title, date and author, if applicable, of publication be cited.

Current JPRS publications are announced in Government Reports Announcements issued semi-monthly by the National Technical Information Service, and are listed in the Monthly Catalog of U.S. Government Publications issued by the Superintendent of Documents, U.S. Government Printing Office, Washington, D.C. 20402.

Indexes to this report (by keyword, author, personal names, title and series) are available through Bell & Howell, Old Mansfield Road, Wooster, Ohio, 44691.

Correspondence pertaining to matters other than procurement may be addressed to Joint Publications Research Service, 1000 North Glebe Road, Arlington, Virginia 22201.

BIBLIOGRAPHIC DATA SHEET	1. Report No. JPRS 70389	2.	3. Recipient's Accession No.
4. Title and Subtitle TRANSLATIONS ON TELECOMMUNICATIONS POLICY, RESEARCH AND DEVELOPMENT, No. 25		5. Report Date 28 December 1977	6.
7. Author(s)		8. Performing Organization Repr. No.	
9. Performing Organization Name and Address Joint Publications Research Service 1000 North Glebe Road Arlington, Virginia 22201		10. Project/Task/Work Unit No.	
12. Sponsoring Organization Name and Address As above		11. Contract/Grant No.	
15. Supplementary Notes		13. Type of Report & Period Covered	
		14.	
16. Abstracts This serial report contains translations from the world press and radio relating to worldwide political, economic and technical developments in telecommunications, computers, and satellite communications. Coverage will be worldwide with focus on France, Federal Republic of Germany, United Kingdom, Italy, Japan, the USSR, People's Republic of China, Sweden, and the Netherlands.			
17. Key Words and Document Analysis. 17a. Descriptors Worldwide Computers Satellite Communications Electronics and Electrical Engineering Telecommunications Telemetry 17b. Identifiers/Open-Ended Terms 17c. COSATI Field/Group 09B, C, F, 17B, 22B			
18. Availability Statement Unlimited Availability Sold by NTIS Springfield, Virginia 22151		19. Security Class (This Report) UNCLASSIFIED	21. No. of Pages 66
		20. Security Class (This Page) UNCLASSIFIED	22. Price PCF04

TRANSLATIONS ON TELECOMMUNICATIONS POLICY,
RESEARCH AND DEVELOPMENT

No. 25

CONTENTS

PAGE

WORLDWIDE AFFAIRS

Norway Protests Soviet Telecommunications Interference (NCNA, 10 Dec 77)	1
Briefs	
GDR TV Agreement	2
PARS-MAP Agreement	2
USSR-Italy TV Agreement	2
Vietnam-Poland Radio-TV Agreement	2

ASIA

INTER-ASIAN AFFAIRS

Telecommunications Delegation Departs Phnom Penh (NCNA, 12 Nov 77)	3
Briefs	
News Agency Meeting	4
PRC/MPR Meteorological Communications	4

INDIA

Briefs	
Satellite Links	5

JAPAN

White Paper Notes Planned Communication Projects (KYODO, 6 Dec 77)	6
---	---

MALAYSIA

Briefs	
Satellite-Aided Instruments	7

CONTENTS (Continued)	Page
MONGOLIAN PEOPLE'S REPUBLIC	
Briefs	
Radio Relay Line	8
PEOPLE'S REPUBLIC OF CHINA	
China Produces Device for Improving Radio Reception (NCNA, 2 Dec 77)	9
SRI LANKA	
Briefs	
National News Agency Launched	10
Japanese Loan for Telecommunications	10
EASTERN EUROPE	
INTERNATIONAL AFFAIRS	
Briefs	
GDR-Hungary Radio Pact	11
EAST GERMANY	
Telecommunications Cooperation Between GDR, USSR Noted (Rudolph Schulze Interview; PRESSE-INFORMATIONEN, 3 Nov 77)	12
HUNGARY	
Telephone Situation, Higher Fees for New Installations Detailed (Tamas Moldovan; NEPSZAVA, 26 Nov 77)	16
YUGOSLAVIA	
Briefs	
Ljubljana Radio, Television Meeting	20
Pozarevac Radio Station	20
LATIN AMERICA	
BOLIVIA	
Briefs	
Telephone Links Via Satellite	21

CONTENTS (Continued)	Page
NEAR EAST AND NORTH AFRICA	
EGYPT	
Briefs	
Earth Satellite Communications Station	22
IRAQ	
Briefs	
Microwave Station Net	23
SUB-SAHARAN AFRICA	
INTER-AFRICAN AFFAIRS	
Briefs	
UNA-JANA Agreement	24
ANGOLA	
Microwave System To Be in Use Soon (JORNAL DE ANGOLA, 16 Oct 77)	25
Radio Licensing Regulations (JORNAL DE ANGOLA, 5 Nov 77)	26
NIGERIA	
Government To Take Control of Radio Stations (Lagos International Service, 9 Dec 77)	29
Radio Sub-Station Opens Mid-December, TV Station in 6 Months (NEW NIGERIAN, 18 Nov 77)	30
Briefs	
Transmitter-Receiver Sale	31
USSR	
Basic Trends in the Development of Transmission Systems for Municipal Telephone Networks (L. T. Kim; VESTNIK SVYAZI, Sep 77)	32
The KLA-600 Automated Control Unit for TU-600 Amplifiers (V. I. Neveykin; VESTNIK SVYAZI, Sep 77)	36

CONTENTS (Continued)

Page

Stimulating a Growth in Labor Productivity
(N. S. Berinashvili; VESTNIK SVYAZI, Sep 77) 42

Briefs

Tashkent-Andizhan Radio Relay 46
Television Broadcasts in Tadzhikistan 46
Vladimirskaya TV Retransmitter 46
Raychikhinsk, Amurskaya TV Station 46

WESTERN EUROPE

INTERNATIONAL AFFAIRS

Briefs

Italian-Portuguese Agreement 47

ITALY

Digital Image Processing System Described
(A. D'Amore, et al.; ALTA FREQUENZA, Jan 77) 48

WORLDWIDE AFFAIRS

NORWAY PROTESTS SOVIET TELECOMMUNICATIONS INTERFERENCE

Peking NCNA in English 1756 GMT 10 Dec 77 OW

[Text] Stockholm, 10 Dec (HSINHUA)--The Norwegian Foreign Ministry once again lodged a protest with the Soviet authorities against the serious interference in Norway's civil telecommunications by the Soviet Union's Kiev Launching Centre, according to a Norwegian newspaper report.

The report says that the protest was made by Tore Boegh, director of the Political and Commerce Department of the Norwegian Foreign Ministry, on 8 December when he summoned a counsellor of the Soviet Embassy in Oslo. Boegh reminded the Soviet side that the Norwegian Foreign Ministry had made representations with the Soviet authorities on the matter a year ago, but such interference has continued up to now. The interference has made grave impact on the work of Norway's Rogaland Radio Station.

The Norwegian side demanded that the Soviet authorities put an end to the interference from the Kiev Launching Centre. He warned the Soviet counsellor that Norway's Rogaland Radio Station is considering boycotts against Soviet vessels.

It was reported that to date, the Norwegian authorities concerned have lodged eight protests with the Soviet authorities concerned. The latest was lodged by the Norwegian Telegraph Bureau just a few days ago.

CSO: 5500

BRIEFS

GDR TV AGREEMENT--Lisbon--ADN Correspondent--An agreement was signed in Lisbon on Friday between the State Committee for TV of the GDR Council of Ministers and Portuguese Radio-Television. Its purpose is to promote cooperation between the two countries in the field of television. [Text] [East Berlin ADN International Service in German 2010 GMT 9 Dec 77 LD]

PARS-MAP AGREEMENT--PARS and the Moroccan News Agency MAP will cooperate in exchanging news under the terms of an agreement signed this morning by Mahmud Ja'farian, supervisor of PARS, and the MAP director general. The two news agencies will exchange news reports on a reciprocal and regular basis, and they also agreed in principle to put their practical experience at each other's disposal through the exchange of visits by experts and officials. [Teheran Domestic Service in Persian 0710 GMT/

USSR-ITALY TV AGREEMENT--A protocol on the prolongation for 2 years of the agreement between the USSR and Italy on cooperation in the field of television was signed today in Rome. It was signed for the Soviet side by Lapin, chairman of the State Committee of the USSR Council of Ministers for Television and Radio Broadcasting, and for the Italian side by Grassi, president of the State Radio and Television Company. The protocol envisages an exchange of broadcasts. An article on the direct transmission to Italy of competitions at the forthcoming Moscow Olympics has a special place in it. [Text] [Moscow Domestic Service in Russian 1900 GMT 7 Dec 77 LD]

VIETNAM-POLAND RADIO-TV AGREEMENT--At the invitation of the Vietnam Radio and Television Broadcasting Commission, a delegation of the Polish Radio and Television Broadcasting Commission led by (Hussak Brenzenev), its general secretary, paid a friendly visit to Vietnam and signed a cooperation agreement with the Vietnam Radio and Television Broadcasting Commission. On 10 December, Ly Van Sau, vice chairman of the Vietnam Radio and Television Broadcasting Commission and (Hussak Brenzenev) representing the Polish Radio and Television Broadcasting Commission, signed the agreement. Attending the signing ceremony, on the Vietnamese side, were Tran Lam, alternate member of the Party Central Committee and chairman of the Vietnam Radio and Television Broadcasting Commission and Vu Quoc Uy, acting chairman of the Commission for Cultural Relations With Foreign Countries and representing the Foreign Ministry, on the Polish side was Josef Puta, ambassador extraordinary and plenipotentiary of the Polish People's Republic to our country. [Text] [Hanoi Domestic Service in Vietnamese 2300 GMT 10 Dec 77 BK]

INTER-ASIAN AFFAIRS

TELECOMMUNICATIONS DELEGATION DEPARTS PHNOM PENH

Peking NCNA in English 1558 GMT 12 Nov 77 OW

[Excerpts] Peking, 12 Nov, 1977 (HSINHUA)--The telecommunications delegation of the People's Republic of China led by Chi Tui-chao, deputy director general of the telecommunications of the Ministry of Posts and Telecommunications, left Phnom Penh for home today after a friendly visit to Democratic Cambodia, according to a report from that city.

The delegation arrived in Cambodia on 29 October. It had discussions with the department concerned of the Democratic Cambodian Government about setting up a telecommunication line between the two countries. The two sides signed on 10 November a "protocol on setting up a telecommunication line between the People's Republic of China and the Democratic Cambodia."

CSO: 5500

INTER-ASIAN AFFAIRS

BRIEFS

NEWS AGENCY MEETING--The meeting of experts on the development of news agencies in Asia being held in Colombo on 7 December proposed that a feasibility study be made up on the establishment of an Asian Network based on the exchange of news between national agencies. The meeting, which began on 5 December, entered its fourth day today and will be concluded on 9 December. [Colombo International Service in English 1045 GMT 8 Dec 77 BK]

PRC/MPR METEOROLOGICAL COMMUNICATIONS--Ulaanbaatar, 11 Dec, 1977 (Hsinhua)-- A protocol on talks between the two groups of specialists in meteorological communications was signed between China and Mongolia here yesterday. The protocol was signed by the two group leaders on behalf of their respective governments. The Chinese and Mongolian specialists held talks in Peking from 24 October to 15 November this year on matters such as promotion of exchange of meteorological information, improvement of the quality of communication lines and on the spot joint test of the lines. [Text] [Peking NCNA in English 1301 GMT 11 Dec 77 OW]

CSO: 5500

INDIA

BRIEFS

SATELLITE LINKS--The communications minister told the Rajya Sabha that India has direct satellite links with 20 countries through the Indian Ocean satellite. Mr Brijlal Verma said all together, 39 countries will have satellite communications with India within the next 2 years. Some of the prominent countries which have direct links with India at present through the system are Australia, the United Kingdom, France, Pakistan and the United Arab Emirates. [Text] [Delhi Domestic Service in English 0830 GMT 9 Dec 77 BK]

CSO: 5500

JAPAN

WHITE PAPER NOTES PLANNED COMMUNICATION PROJECTS

OW060535Y Tokyo KYODO in English 0515 GMT 6 Dec 77 OW

[Excerpt] Tokyo, Dec 6 KYODO--A white paper on communications announced Tuesday by the Posts and Telecommunications Ministry took note of the importance of satellites as a means of communications. This year's white paper, the fifth in the annual series to be published so far, was reported to the cabinet meeting Tuesday by Posts and Telecommunications Minister Yasushi Hattori.

It said much is being anticipated from space communication through use of artificial satellites which enable the establishment of communication networks over long distances and on a wide-scale basis. It also said use of satellites can enable communication to be conducted simultaneously among various points and make possible the use of the still-uncultivated extremely high frequency radio waves.

The paper said the government established the National Space Development Agency (NASDA) in 1969 and that the University of Tokyo succeeded in launching the Ohsumi, Japan's first satellite, in 1970. It also noted that various space communication projects were being undertaken at present. The white paper said Japan's first medium capacity communication satellite (CS) will be launched into stationary orbit December 15 through the help of the U.S. National Aeronautics and Space Administration (NASA).

There also are plans to launch an experimental stationary communication satellite (ECS) and an experimental medium capacity broadcasting satellite (BS). The paper said the ECS project is being undertaken to conduct tests on use of extremely high frequency radio waves of 30 gigahertz or more for communication purposes. The ECS satellite is expected to be placed into orbit by use of a N-rocket of NASA in February 1979.

As future problems facing Japan in undertaking space communications projects, the white paper said there was need to draw up a long-range vision based on national consensus and establish a structure in which the country will not need to rely on foreign technology. It also said there was need to make international adjustments on radio air wave bands and orbital paths of satellites.

CSO: 5500

MALAYSIA

BRIEFS

SATELLITE-AIDED INSTRUMENTS--Modern demarcation instruments guided by space satellites will be used to map out the Sabah-Sarawak-Kalimantan border by 1980. The joint chairman of the Indonesia-Malaysia border demarcation committee, Datuk Harun Arifin, and Major General Pranoto of Indonesia said this in Kuala Lumpur. [Text] [Kuala Lumpur International Service in English 0630 GMT 2 Dec 77 BK]

CSO: 5500

MONGOLIAN PEOPLE'S REPUBLIC

BRIEFS

RADIO RELAY LINE--Ulaanbaatar, 23 Nov--Construction of a new radio relay line from Ulaanbaatar to the country's far western regions is underway. Residents of this remote area will soon be able to view central television programs. During the current five-year plan period, nearly five times more funds are being directed in the MPR into the development of communications than during the previous 5-year period. [Ulaanbaatar MONTSAME in Russian 1824 GMT 23 Nov 77 OW]

CSO: 5500

CHINA PRODUCES DEVICE FOR IMPROVING RADIO RECEPTION

Peking NCNA Domestic Service in Chinese 0309 GMT 2 Dec 77 OW

[Newsletter: "Feng Ping-chuan, an Old Professor Who Has Regained His Youthfulness"]

[Excerpts] Canton, 2 Dec--Upon the smashing of the "gang of four" by the party Central Committee headed by the wise leader Chairman Hua, the trial production of a radio frequency wave clipping language processor [She Pin Hsiao Po Yu Yen Chia Kung Chi 1410 7340 0465 3134 6133 6056 0502 1562 0892] was immediately resumed. It was designed by Professor Feng Ping-chuan of the South China College of Engineering.

According to departments concerned, radio reception in China's border areas and outlying regions of broadcasting stations in the interior is not good due to the serious interference of enemy stations. In the light of this situation, Feng Ping-chuan conducted research on the problem, presented for the first time in China the theory on radio frequency wave attenuation language processing, and designed the radio frequency wave clipping language processing device based on this theory. This device improves reception, expands the reception area and raises the anti-interference capability of a station without having to increase the power of the station.

After he learned of several new types of radio transmitters in the world some years ago, he made a detailed analysis and study of those transmitters and theoretically confirmed their advantages and shortcomings. By considering China's specific situation and learning the strong points of those transmitters, he was able to design a transmitter of his own. In cooperation with relevant factories, he finally built China's first 10-kw wide-band pulse modulation AM radio transmitter.

CSO: 5500

SRI LANKA

BRIEFS

NATIONAL NEWS AGENCY LAUNCHED--LANKA (?report), the National News Agency, got off the ground last week. This agency, which will provide national news to the news media in this country, is being worked by the Ministry of Information and Broadcasting and the press trust of Ceylon. Eventually, the agency will receive its news through SLBC [Sri Lanka Broadcasting Corporation] transmitting facilities. The national newspapers and the Sri Lanka Broadcasting Corporation will contribute toward financing the operation. [Text] [Colombo International Service in English 1045 GMT 4 Dec 77 BK]

JAPANESE LOAN FOR TELECOMMUNICATIONS--An exchange of letters took place in the Ministry of Finance and Planning on 2 December under which the Government of Japan will provide a loan of approximately \$8 million for the economic development of Sri Lanka. This loan will be used for the installation of telecommunications facilities in six major cities and the expansion of the local (?telephone) exchange of the Colombo central office planned by the Government of Sri Lanka. The loan is repayable in 30 years including a grace period of 10 years and the rate of interest is 3.5 percent per annum. [Colombo International Service in English 1045 GMT 2 Dec 77 BK]

CSO: 5500

INTERNATIONAL AFFAIRS

BRIEFS

GDR-HUNGARY RADIO PACT--The GDR and the Hungarian People's Republic today concluded a new radio broadcasting agreement. The [word indistinct] agreement, signed by the chairman of the State Broadcasting Committee, Rudi Singer, and the chairman of Hungarian Radio, Dr Istvan Hars, deepens cooperation between editors and develops exchanges of experiences in all spheres of broadcasting work. The work protocol for 1978-1979 was signed at the same time. [Text] [East Berlin Voice of the GDR Domestic Service in German 1300 GMT 7 Dec 77 LD]

CSO: 5500

TELECOMMUNICATIONS COOPERATION BETWEEN GDR, USSR NOTED

East Berlin PRESSE-INFORMATIONEN in German No 130, 3 Nov 77 pp 2-3

[Interview with Rudolph Schulze, deputy chairman, GDR Council of Ministers and minister for posts and telecommunications: "Intensive Cooperation Between GDR and USSR Posts and Telecommunications"]

[Text] [Question] There has been long-term cooperation between the GDR and USSR in the area of posts and telecommunications. How did it develop and what does it include?

[Answer] Since the Soviet people's victory over fascism, a sincere friendship has united us with the comrades and friends of the communications administration in the country of the Red October. It was Soviet postal, telecommunications and radio specialists who gave us irreplaceable assistance in building our new socialist communications administration.

As early as July 1950, we signed three interdepartmental agreements concerning postal, parcel and telecommunications service. Communication links between our two countries then developed from this foundation. Scientific-technical cooperation also grew considerably and turned out to be increasingly advantageous for strengthening the industrial-technological basis of our brother countries' posts and telecommunications.

As a result of steadily increasing communications service between the GDR and USSR, scientific-technical cooperation and many personal contacts and consultations, these interdepartmental agreements were superseded on 19 October 1966 by a government agreement on communications. It formed the cornerstone for a new standard of quality in GDR and USSR posts and telecommunications relations, which were growing closer and closer. I would like to list a few select examples. On the 20th anniversary of our republic, we were able to have automatic telephone service between the capital of the GDR, Berlin, and the capital of the USSR, Moscow. Two years later, we signed the agreement for creating the international "Intersputnik" system in Moscow for cosmic communication connections and the agreement for young postmen to work together on the Drushba line followed in the spring of 1975.

And in the struggle to secure our rights in international bodies, such as the International Telecommunications Union (ITU) and the Universal Postal Union (UPU), the Soviet Union has also always proved to be a true friend. Our Soviet friends participate a great deal in the constructive and creative work of the CEMA Standing Committee for Posts and Telecommunications and other organizations of socialist countries in the communications field.

From 1976 to 1980, the scientific establishments of both communications administrations will jointly solve a considerable number of long-term work tasks in posts and telecommunications research and development and engineering and technology. They are planned so that results can be quickly put into operation in the communications networks of both countries.

[Question] Thus science and technology represent the focal point in this case as well. Can you tell us what results this has brought for both sides?

[Answer] The USSR's great scientific-technical achievements in telecommunications are of vital importance for the further development of posts and telecommunications in all socialist countries. There is a large number of integration projects and tasks in the framework of scientific-technical cooperation. Let me list two examples. On the basis of a government agreement, joint work is being carried out in the GDR and USSR on the development, testing and production of a uniform system of electronic communications technology.

A further task is the standardization of radio interference elimination regulations. As a result, important conditions are being created for the constantly increasing import and export of machinery, industrial installations and industrial consumer goods. The already existing compulsory standards for both countries for eliminating radio interference from fluorescent light fixtures or internal combustion engines help considerably to provide television and radio reception that is free of interference.

[Question] Radio and television form an electronic bridge between our brother countries; newspapers and periodicals from the Soviet Union are in demand among our citizens. What achievements is the German Postal Service making in this connection?

[Answer] With recorded programs and direct broadcasts of political events, sports matches, cultural events on economic, scientific, technical and other achievements, there is active communication on the electronic bridge between our brother countries. Technical studio installations, broadcasting channels and transmitters form part of this bridge over which radio and television programs reach our country. An increasing percentage of our technical installations use Soviet instruments and equipment which,

to a certain extent, were jointly developed by GDR and USSR specialists. As an example, I would like to cite Soviet color television technology, which has already stood the practical test in the Rostock Baltic Sea studio and some studios in Berlin-Adlershof. We are also using Soviet mobile color television transmission units.

The international "Intersputnik" system and organization is part of our communications network. With the help of ground radio stations and telecommunications satellites, evidence of the high efficiency of Soviet researchers, design engineers and workers, the bridge uniting peoples stretches from the Mongolian People's Republic to Cuba, transmitting telephone calls and radio and television programs.

Part of the bridge uniting peoples are also naturally printed publications from the land of friends, which the German Post Office offers to GDR citizens by subscription and in newsstands or other sales outlets of the postal news distributing service.

In the honors competition of the 60th anniversary of the Great Socialist October Revolution, our fellow workers have surpassed the objectives for soliciting subscriptions to Soviet publications by more than 100 percent. In only 10 months, 210,000 new readers were acquired. This is the highest figure ever reached in this area, of which German postal workers are also justifiably very proud.

The development of circulation recorded in recent years is very clear evidence of our citizens' interest in Soviet newspapers and periodicals. We imported 500,000 issues in 1976 and the figure was already 730,000 by October 1977. Such periodicals as SOVIET UNION, THE SOVIET WOMAN and SPUTNIK, with 120,000, 225,000 and 78,000 issues, are among USSR publications most in demand.

The desire of our citizens to keep up with the political, economic, cultural and military development of the Soviet Union is very broad. The German Post Office therefore maintains a constant supply of almost 2,000 titles--14 of which are in German. Finally, importing over 1,200 Soviet technical and scientific journals makes it possible to take advantage of the USSR's rich wealth of experience without delay in the GDR. It should also be mentioned that the principal daily newspapers of both countries are shipped by air and sold on the day they are published or the following day.

[Question] You signed a new government agreement, together with the USSR minister for posts and telecommunications, N. W. Talysin, doctor of engineering, in the middle of this year. What goals do you thereby hope to achieve?

[Answer] We concluded this agreement in order to further extend relations in the area of posts and telecommunications on the basis of the National

Treaty on Friendship, Cooperation and Mutual Assistance. As a result of joint measures, the quantity and quality of telecommunications transmissions and channels for broadcasting television and radio programs are being increased in accordance with the latest scientific-technical knowledge. We are endeavoring to exchange and generalize practical knowledge in organizing and operating posts and telecommunications even more quickly and to join the bonds of friendship even more closely between collectives.

Both communications administrations have pledged to improve the quality of postal services, to increase the efficiency of existing or future postal connections and to simplify current mailing regulations.

With the conclusion of the government agreement, the contracting parties have proved that long-standing close and friendly cooperation is being unrestrictedly continued, broadened and deepened.

11915
CSO: 5500

HUNGARY

TELEPHONE SITUATION, HIGHER FEES FOR NEW INSTALLATIONS DETAILED

Budapest NEPSZAVA in Hungarian 26 Nov 77 pp 1, 3

[Article by Tamas Moldovan]

[Text] The telephone is a means of mass communication and information, and one of the most important tools of ever increasing international contact, economics, and private life, which now has become indispensable. By the same token, however, it has also become a source of care and nervous anxiety. We must wait long for interurban connections, it is difficult to get a line, we often get the wrong number, and the waiting list for new subscribers is increasing.

Arpad Toth already had written: "My head aches, my mother is smarting, my telephone difficulties are torturing." We are not consoled, however, by the fact that the ills of the telephone system are not of recent origin. If we were to make up the patient's chart, the diagnoses would include: overloaded switching centers, Hungary is lagging far behind development of the European average, the cable network is outmoded and oversaturated, and breakdowns are frequent, and last, but not least, we have not learned to use the telephone properly. It must be added, however, that this area is characterized by undeniable achievements more than by faults. In fact, Hungary now has 1 million 81 thousand telephone subscribers, assistance requesting stations have day and night contact with almost all communities, and by 1980 long distance calls may be initiated from 180 villages and cities. Automation of international connections is progressing well, having been established with subscribers of 27 countries at present.

Hungary is not bad off, compared to the world average: we have 9.91 phones per 100 population, compared to the world figure of 9.6. We do not approximate the level of many socialist and capitalist countries, however, This figure for Czechoslovakia is 17.62, is 28.13 in neighboring Austria, and is highest in Sweden, with 66. What is the reason for the lag? During World War II the Hungarian telephone network was almost completely destroyed. Most European countries devote at least two percent of their investment resources to development of the telephone network. In Hungary this ratio has ranged between 0.6 and 1.5 percent during the past 20 years. Following Liberation all resources had to be devoted to reconstruction and creation of a basic network. In the Fifth Five-Year Plan approximately 50 percent more will be expended for development of this field, increasing the capacity of telephone centers by 280,000 stations, more than 80,000 of which must be used to replace outmoded equipment. During past months, as Deputy Minister Dezso Horn, Director in Chief of the Post Office told journalists on Friday, the Government has repeatedly dealt with possible solutions and their related measures.

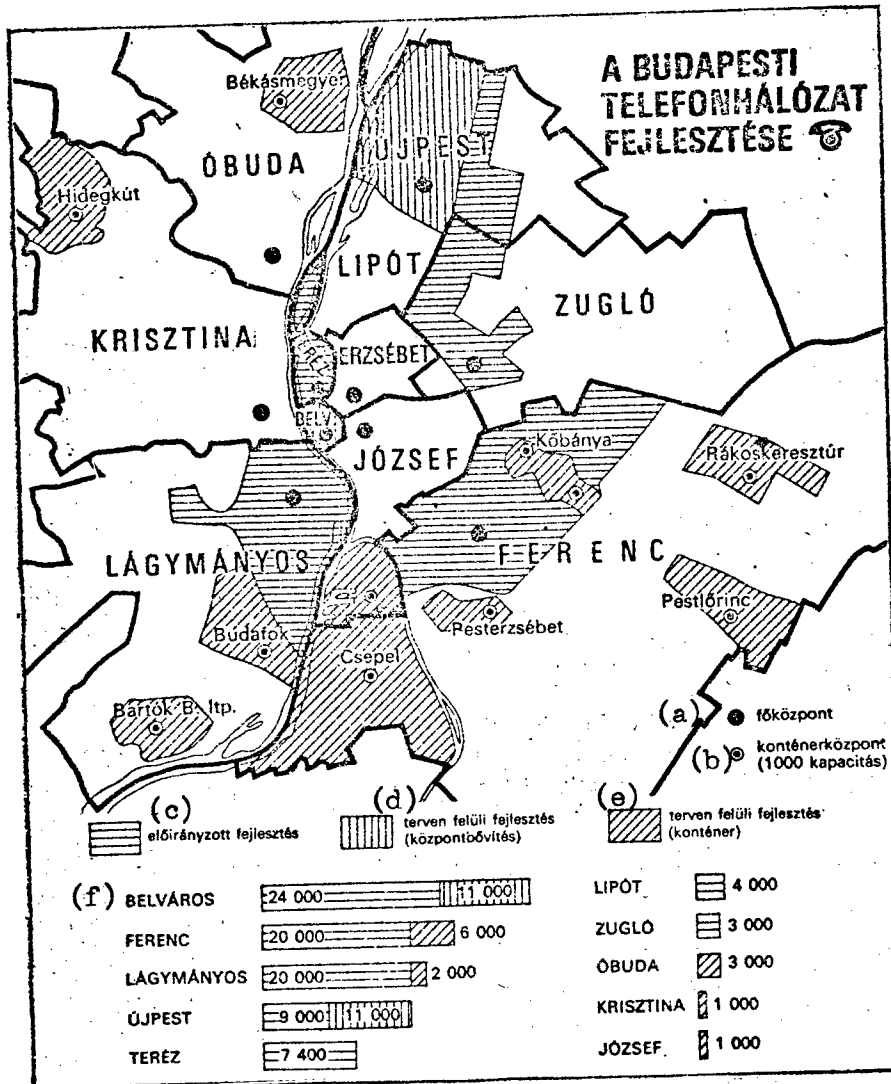

Development of the Budapest Telephone Network.

Key:

- (a) Main central exchange
- (b) Container center (1,000 capacity)
- (c) Planned development
- (d) Development in excess of plan (center expansion)
- (e) Development in excess of plan (container)
- (f) Inner city

At the press conference, in which Istvan Soltesz, Department Head of the Council of Ministers Office of Information, participated, the Deputy Minister emphasized that one of the sources of difficulty is that more than 60 percent of total traffic occupies only 56,700 subcentral main lines, while the 331,000 population stations represent only 8 percent. Many centers are nearly 100 percent saturated; village installations are almost entirely of the manual type; thus 70 to 80-year old technology is represented together with the most modern crossbar equipment in the technical composition of the Hungarian Postal Service. Of the Budapest cables 46 percent are more than 20 years old, and many are of the type installed 40 to 50 years

ago. Gas infiltration, the exceptionally high traffic, and the action of electricity have had increasingly telling effect on the cable jackets. At the shops, the condition of the subcenters is considered of secondary importance, and little attention is devoted to training of maintenance personnel and to more frequent replacement of equipment. According to a study of the OMF [National Technical Development Committee] time lost due to telephone malfunction is increasing, causing an estimated 2 billion forints loss each year.

What is the solution? First of all a proper industrial and technical background had to be created: at present Beloiannisz Communications Technology Factory is able to fulfill all orders of the Post Office, and the Hungarian Cable Works are geared up for production of new types of cables that resist rain and other adverse factors. Renovation of the old centers and construction of new centers must be resolved at the same time. They are simultaneously providing for modern modification of cable and for the use of synthetic protective materials to insure rapid elimination of mass disorders that are still commonplace. In the future, it is intended to prevent overloading of centers through effectuation of a qualitative change. It should not be overlooked, however, that despite considerable progress, there is a present list of more than 257,000 subscriber applicants awaiting installation, compared to 138,000 in 1970. According to estimates, this figure will continue to increase because the demand for telephones is a justified need accompanying the increase in standard of living. In the meantime there is great tension in this regard, and nationally standard rules of priority must be applied, taking into consideration public institutions and subscribers to be accorded priority on the basis of public interest or need of a telephone connected with occupations.

The cost of installation of one new station, taking into consideration network and center construction, and other costs, is 36,000 forints. The capacities of the national economy also must be taken into account. We discussed this problem in the NEPSZAVA Dosszie column a few weeks ago, suggesting that the state and the applicant make increased contributions to the installation cost, at least equivalent to the cost of one new television set, and that plans be implemented more rapidly. On the basis of an earlier provision, industrial plants and institutions are paying 30,000 forints for a main line, and 20,000 forints for a twin party line. Deputy Minister Dezso Horn reported that a final decision has been made, requiring of individual subscribers to contribute 6,000 forints toward the investment costs of a main line, and 4,000 forints for twin party lines beginning with 1 January 1978. This measure will represent an increase in revenue of 300 million forints by 1980, and a further increase of one billion forints will be attained by a 100 percent increase in telephone center fees of enterprises and institutions based on governmental decree, beginning with 1 January. The detailed implementation order is now in preparation, and detailed instructions relative to the installations and station transfers will be issued before 1 January. We suggest, however, that it would be justified for the OTP [National Savings Bank] to extend credit for pensioners and persons with low income for the purpose of telephone installation, just as they receive aid for purchase of goods.

The public contribution toward installation costs and the increase in enterprise fees will enable installation of 45,000 more telephone stations

than originally planned for installation by 1980, primarily in the Inner City, Ujpest, Bekasmegyer, Csepel, Kobanya, Pestlorinc, Bartok Bela Community, Budafok, Pesthidegkut, Rakoskeresztur, Pesterzsebet, Gyor, Szekszard, Baja, Kiskunhalas and Ajka. The new container centers are being used for the first time; they are being installed primarily at new housing developments and in outlying areas, and when the main center will be completed they may be extended further. This will also enable reduction in installation costs.

It was stated at the press conference that the Post Office is a service enterprise, and thus it strives toward acceleration of traffic and improvement of existing conditions in all areas. The most important role in realization of this goal falls on the shoulders of the ten of thousands of postal employees.

5200
CSO: 5500

BRIEFS

LJUBLJANA RADIO, TELEVISION MEETING--The third session of the Assembly of the Ljubljana Radio-Television on 21 November in Ljubljana examined a draft of the main guidelines on the development of the technical foundations of the institution until 1980 and the basic guidelines for the preparation of radio and television program schedules for 1978. No great changes are expected in the radio programs, but it was said that information programs "will all have to become more up-to-date more quickly, which means that they will have to shed the present journalistic attributes and to draw primarily on the specific opportunities presented by the radio medium." A new transmitter at Domzale will begin transmitting next fall. The first television program will not expand in 1978. [Ljubljana DELO in Slovene 22 Nov 77 p 2 AU]

POZAREVAC RADIO STATION--A new radio broadcasting station broadcasting on 240 meters mediumwave and on 92.1 MHZ began operating in Pozarevac recently. It is part of the REC NARODA newspaper and broadcasting organization. The purchase and installation of the radio equipment cost 4 million dinars. The radio station operates on the strength of 1 kilowatt. [Belgrade BORBA in Serbo-Croatian 14 Nov 77 p 9 AU]

CSO: 5500

BOLIVIA

BRIEFS

TELEPHONE LINKS VIA SATELLITE--The National Telecommunications Company [ENTEL] has reported that Bolivia and Argentina linked up their telephone systems via satellite yesterday. ENTEL also reported that telephone channels will be opened in the near future with Brazil and Spain via Lima. [La Paz Radio Panamericana in Spanish 1130 GMT 30 Nov 77 PY]

CSO: 5500

EGYPT

BRIEFS

EARTH SATELLITE COMMUNICATIONS STATION--The Communications Ministry First Under Secretary Eng 'Abd al-Mun'im al-Muhandis has said that the telecommunications authority will begin operating the earth satellite communications station in March. He added that operating the new station will boost television transmissions, transmit external programs and world events when they are broadcast and boost external telephone communications. [Text] [Cairo Domestic Service in Arabic 0600 GMT 29 Nov 77 NC]

CSO: 5500

IRAQ

BRIEFS

MICROWAVE STATION NET--Fifty new microwave stations are currently being built, in addition to the stations already in existence throughout the country, during the second stage of the microwave station expansion project. A source in the State Establishment for Post, Telegraph and Telephone announced the above to an AL-THAWRAH correspondent and said that six of these stations have just been completed and the rest are under construction within the context of a great plan to bring telephonic communications to [even] the smallest administrative units in the country. He added that the project was begun 3 years ago. Fifty stations were completed during the first stage at a total cost of 8 million dinars. [The source] mentioned that the microwave project relies on automatic equipment, which facilitates direct telephonic communication among the governorates without the intermediary of an exchange and which lessens the pressure of handling telephone calls through the exchanges. On another level, the State Establishment for Post, Telegraph and Telephone has undertaken the expansion of ten PTT offices, with new equipment and materiel. Work is now being done to establish 12 other offices at a cost of 1.5 million dinars within the establishment's plan to provide better services to the citizens and facilitate telephonic and postal communications operations. [Text] [Baghdad AL-THAWRAH in Arabic 25 Nov 77 p 4]

CSO: 4802

INTER-AFRICAN AFFAIRS

BRIEFS

UNA-JANA AGREEMENT--Uganda and Libya signed a news exchange agreement in Tripoli yesterday. The nine-article agreement gives the Uganda News Agency, UNA, the right to receive free of charge from the Libyan News Agency, JANA, telecast news reports beamed to the African continent. UNA, in turn, will provide JANA with important news items. A training program is being arranged for UNA technicians in Tripoli. The agreement is automatically renewable every year. Sources close to President Amin quote him as saying that his is yet another important step towards the realization of the Pan-African News Agency, PANA. [Kampala Domestic Service in English 1700 GMT 9 Dec 77 LD/EA]

CSO: 5500

MICROWAVE SYSTEM TO BE IN USE SOON

Luanda JORNAL DE ANGOLA in Portuguese 16 Oct 77 p 2

/Text/ The meeting of provincial communications delegates with the officials in charge of that field of activity came to a close Friday in Luanda. At the end of the proceedings, comrade Maj Bento Ribeiro (Kabulo), secretary of state for communications, summed up the conclusions which will guide that field of activity in the next few months, whose most important aspects are worth noting.

With regard to the relationship between the provincial delegations and the central services, an extensive administrative and financial decentralization was decided for the prerogatives of the delegates, who should, in the meantime, submit all matters lacking authorization on the part of the central services to the prior approval of their respective provincial commissars.

As to the performance of the immediate tasks, emphasis was placed on the importance of rural communications, which should be vitalized by the opening of post offices and the activation of mail services on the regular rail and road transports. Attention was also called to the importance of permanent reconstruction and protection of the interurban communications system, and to the implementation of the plans for technical improvement, occupational training and literacy.

In the plans in effect, special emphasis was given to the microwave project which should shortly replace the current interurban network and permit nationwide television broadcasting, and tasks have been defined within each province.

Concerning the incorporation of the provinces of eastern Angola into the national communications network, consideration was given to the projects of using radio operators in the landlines of the Benguela and Mocamedes railroads, which will permit the extension of the telex public service to the provinces of Moxico and Cuando-Cubango.

Regarding the undertakings in the area of the training of cadres, an analysis was made of the needs up to 1980 in the light of the projects of occupational training in effect, which are sponsored by the Universal Postal Union and the International Telecommunications Union, and financed by the UN development program.

8414
CSO: 5500

RADIO LICENSING REGULATIONS

Luanda JORNAL DE ANGOLA in Portuguese 5 Nov 77 pp 2, 6

/Text/ By directive #56/77, Maj Bento Riveiro, secretary of state for communications, has ordered the cancellation of all authorizations for the installation of radio facilities issued to the group of enterprises designated as "Highway," and has established a time limit for inventorying all equipment in the possession of those concerns. The mentioned directive reads as follows:

"Whereas Directive #59/77 of 8 September of the Ministry of Construction and Housing, published in the Journal of the Republic issue #213, 1st series, of 8 September, orders an intervention in the various enterprises of the construction sector which comprise the group designated as "Highway," under the direct control of that ministry.

"Whereas the group includes the firms of SOCROL (Sociedade de Construcoes Rodrigues, Lda /Rodrigues Construction Co, Ltd/), Jomasil (contractors), SARL /not further identified/, SECOL (Sociedade de Construcoes e Engenharia Lda /Construction and Engineering Co, Ltd/), and TECNIL (Sociedade Tecnica e Industrial de Construcoes Lda /Technical and Industrial Construction Co, Ltd/), which have authorization to install radio facilities, I decide:

"a) Under the terms of Article 48 of the Radio Services Regulations in force, all authorizations for the installation of radio facilities granted to those enterprises are revoked;

"b) The managements of the "Highway" group of enterprises must submit to this Secretariat of State within a period of 30 days, to start from the date of this directive, an inventory of all radio equipment in the possession of the mentioned enterprises for the purpose of ascertaining eventual responsibility and determining their use."

This directive is dated 19 October 1977, and is published in the Journal of the Republic issue #256, 1st series.

Licensing of Radio Facilities

Another directive of the secretary of state for communications bearing reference #54/77 establishes measures to normalize the situation with respect to the licensing of radio facilities and the control of the radio spectrum. We transcribe the directive in question:

"Whereas Decree #3-A/76 of 5 February provides that the licensing of radio facilities and the control of the radio spectrum are under the purview of this Secretariat of State as exercised by the Telecommunications Coordination Commission and General Directorate;

"Whereas those functions were formerly assigned to the Postal and Telecommunications Services Directorate, as stipulated by Decree #492/73 of 4 October;

"There being a need to normalize the situation, I decide:

"1 - To discontinue all activities of the Postal and Telecommunications Services Directorate relative to the licensing of radio facilities and the control of the radio spectrum, which become the responsibility of the Radiotelecommunications Division of the General Directorate of this Secretariat of State.

"2 - The Postal and Telecommunications Services Directorate will transfer to this Secretariat of State all pending or incoming cases, as well as any papers concerning those activities.

"3.1 - The radio monitoring activity is assigned to the Postal and Telecommunications Services Directorate under the terms of the present directive.

"3.2 - The collection of duties and fines in connection with the licensing of radio facilities will be done at the telegraph offices of the Postal and Telecommunications Services, and the corresponding receipts will be issued by the Radiotelecommunications Division.

"4 - The Third Department of the Second Division of the Central Technical Services Directorate of the Postal and Telecommunications Services is abolished.

"5 - The Radio Monitoring Center of Luanda is created in place of the Third Section of that department, and it is placed in charge of the Second Division of the Central Technical Services Directorate of the Postal and Telecommunications.

"6 - The Radio Monitoring Center of Luanda will be operationally dependent on the Radiotelecommunications Division of this Secretariat of State, and its duties will be:

"To conduct surveys in accordance with existing regulations;

"To perform periodic inspections of radio facilities;

"To carry out technical checkups of radio transmissions.

"7 - The Postal and Telecommunications Services will give the Radio Monitoring Center of Luanda all the necessary assistance for the performance of its tasks, particularly with regard to personnel, transportation and facilities, including the improvement of its equipment, and this will take place in accordance with a program which will be set up by this Secretariat of State.

"8 - As long as it is not possible to extend the radio monitoring structure to the whole country, the technicians of the Second Division of the Technical Postal and Telecommunications Services Directorate will be used within their capabilities to carry out monitoring activities in the provinces where they are employed. In this situation, the activity will be requested in each particular case from the chief of that division or from the provincial delegate.

"9 - Whenever the monitoring center or one of its agents detects contacts outside the scope and purpose for which the facilities were licensed, the costs involved in such activity will be borne by the culprits.

"10 - With the granting of permission for the installation, owners are bound to guarantee free access to the facilities to employees engaged in the monitoring activity, as well as to public officials or police officers whose intervention they request.

"11 - Within the existing conditions, the Radio Monitoring Center of Luanda will be provided, as it becomes practicable, with the following personnel: one chief of center, CST /expansion unknown/ 1st class or CSE /expansion unknown/ 1st class; three assistant chiefs, radiotelegraph operators 1st class; three operators, radiotelegraph operators 2d and 3d class; two monitors, chief or 1st class telecommunications technicians; one assistant, installer 1st or 2d class; and one messenger, office boy 1st or 2d class.

"12 - The chief of the Radiotelecommunications Division together with the chief of the Radio Monitoring Center must promote the training and improvement programs designed to prepare the personnel for the performance of their duties and their eventual qualification as radio monitoring technicians.

"13 - All papers which were in the care of the first and second sections of that Third Department are transferred to this Secretariat of State without further notice."

8414
CSO: 5500

NIGERIA

GOVERNMENT TO TAKE CONTROL OF RADIO STATIONS

Lagos International Service in English 1530 GMT 9 Dec 77 LD

[Text] The Federal Military Government is to assume responsibility for all state radio stations broadcasting on short wave and those with powerful medium-wave transmitters capable of reaching audiences outside the areas of their jurisdiction. The effective date is 1 April 1978.

A cabinet office explanation in Lagos said that as from this date control of the stations will be vested in the Federal Military Government, which will be responsible for their funding, staffing and development. The stations will continue to enjoy operational autonomy similar to that enjoyed by these television stations taken over by the federal government.

In view of the reputation of some of the stations--and the reputations were built over a long period--the nature of the programs they offer, as well as the need to retain their large listenership of programs tailored for listeners in local languages, it was decided that everything possible should be done to maintain the distinctive character of these radio stations. The Federal Military Government has, therefore, appointed a panel to determine ways of implementing its decisions. The team comprises the chief executives of all radio stations affected, the Nigerian Broadcasting Corporation and representatives of the federal cabinet office, federal ministries of Information, Establishments and Justice. The permanent secretary, Federal Ministry of Information, will head the panel.

CSO: 5500

RADIO SUB-STATION OPENS MID-DECEMBER, TV STATION IN 6 MONTHS

Kaduna NEW NIGERIAN in English 18 Nov 77 p 21

[Text]

THE Nigerian Broadcasting Corporation, [NBC], would by middle of December this year, open another radio sub-station in Yola, Gongola State capital.

Giving details of the exercise when he met the state's acting Military Governor, Colonel B.A. Idiagbon, the Federal Commissioner for Information, Mr. Ayo Ogunlade, said the station — would certainly start broadcasting its programmes before Christmas, this year.

He told the governor that the installation of transmitter and other necessary machinery was almost over. All being "well, you will be able to tune to Radio Gongola by middle of December," the commissioner emphasised.

Mr. Ayo Ogunlade further told the governor that a temporary transmitter would be provided for a start, adding that "to make it faster," the one at Wukari would be transferred to Yola for a link up with air satellite, he said. He explained that whenever that was

done, the whole state would be able to receive national programmes.

He further added that the particular transmitter in question had an effective coverage radius of between 100 — 200 kilometres. This could be increased in the near future.

The commissioner however pleaded with the governor to press on the National Electric Power Authority, (NEPA), to provide electricity to the Radio Station.

Similarly, Mr. Ayo Ogunlade, disclosed to the governor that Yola Television Station would be in full use within six month's period.

In the same token, he requested the state government to provide a piece of land for the television station. He said this should not be far away from the state capital's power house, for the sake of effective television transmission, he explained.

Likewise, the commissioner went on, the federal government would also buy an outside

broadcast van to enable the television station to record live programmes.

In his reply, the acting Military Governor, Colonel, B.A. Idiagbon, called on the federal government to give priority to Gongola State in respect of setting up television and radio stations," bearing in mind our distance from the federal capital and our communication problems," he stressed.

Colonel B.A. Idiagbon, then disclosed to the commissioner that in order to hasten the installation of the television, the state government might construct a temporary station. He explained that this would facilitate for a quick take off of the exercise.

CSO: 5500

NIGERIA

BRIEFS

TRANSMITTER-RECEIVER SALE--Marconi Communications Systems [a British company] will supply the Nigerian Broadcasting Corporation (NBC) with three 10 kw FM transmitter-receivers with the associated antennas at a total cost of 160,000 pounds sterling. The equipment will become operational by the end of November. [Text] [Paris ELECTRONIQUE ACTUALITES in French 25 Nov 77 p 9]

CSO: 5500

USSR

UDC 621.395.4

BASIC TRENDS IN THE DEVELOPMENT OF TRANSMISSION SYSTEMS FOR MUNICIPAL TELEPHONE NETWORKS

Moscow VESTNIK SVYAZI in Russian No 9, Sep 77 pp 19-20

[Article by L.T. Kim, candidate of the engineering sciences, with the Central Scientific Research Institute for Communications]

[Text] In the current five-year plan, KAMA and IKM-30, as well as single channel AVU [HF subscriber installations] type transmission systems are being widely introduced on municipal telephone networks (GTS). The efficient use of this multiplex equipment on interexchange lines will promote the implementation of the resolutions of the CPSU Central Committee "On measures to accelerate the development of the nation's telephone communications."

The KAMA equipment is being employed primarily to create interexchange junction line (SL) trunks. It operates via a two-wire, two-way circuit, primarily on MKS cables, in which all pairs can be multiplexed. Used for matching to the switching equipment are RSLU relay matching complexes of various types -- in accordance with the function of the given line. KAMA equipment has demonstrated good operational reliability and is comparatively inexpensive: in a 30 channel complex, the equipment cost of the terminals figured on a per channel basis amounts to about 300 rubles, while in a 120 channel complex, 200 rubles.

Cables of the VTSP and KSPP types can also be multiplexed with the KAMA system (organizing up to 60 channels over a distance of up to 50 km), type TZ cables (no less than one pair in a lay for the same communications range), as well as type T cable (using a two cable circuit with a communications range up to 20 km and multiplexing up to five percent of the pairs). In the latter case, one is to be governed by the "Temporary recommendations for using KRR [cable-radio repeater] equipment to multiplex twisted pair cables with air-paper insulation (Type T)" of 1964.

By using the appropriate relay complexes, the KAMA system can be effectively used to create a trunk of subscriber lines (AL). In this way, for example, it is possible to solve the problem of output to a GTS [municipal telephone

network] for many large scale enterprises and institutions, without engaging in cable work. However, these additional capabilities of the KAMA system are as yet being little utilized.

It should be underscored that the production volume of KAMA equipment far from satisfies the present day needs of GTS's. In the future though, it can become obsolete, thus without having had time to achieve that economic effect which it could produce at the present stage of development of GTS's.

A significant increase in the production volume of other equipment intended for GTS's is also required: for the IKM-30 transmission system. This equipment operates via a four wire, one or two cable circuit on type T cables with a repeater section length of 1.8 - 2.5 km (T-0.7 cable), but can also be used on other cables. Housed in the analog-digital equipment bay (SATsO) are four groups of 30 channels each with electronic matchers (SU), which provide for the capability of utilizing the channels as interexchange junction lines. The equipment of the line channel is housed in a second bay (the SOLT). The system can also be packaged in one bay (for small exchanges).



The KAMA multiplex equipment

planned is an improvement in part of it to increase the range and improve individual parameters. The production volume of AVU's is increasing.

Besides those cited here, other communications systems can also be employed on GTS's. For example, small trunks of junction or subscriber lines (to individual enterprises, switchboard installations) can be created by means of the V-2 equipment, multiplexing a type T cable with it and providing for an operational range of up to 10 - 15 km.

For communications across rivers and bays, it is convenient to employ the "Elektronika-M" single span, digital SHF radio link, which is being produced

The price of the IKM-30 is as yet approximately twice as high as that of the KAMA system, but is exhibiting a tendency to decrease.

It is necessary to develop electronic matchers to use the IKM-30 channels as subscriber lines.

Being introduced at the present time on subscriber lines are high frequency subscriber installations, AVU, which provide for the capability of connecting a second subscriber to an in-use subscriber line, where both are completely independent. A line to a pay phone, a switchboard, etc., can also serve as the multiplexed line. The new subscriber should have a standard telephone set. It is also convenient to employ an AVU to meet temporary communications needs: in organizing conferences, summer camps, rest areas, etc. The equipment is convenient and reliable in operation. Now being

by enterprises of the Ministry of the Electronics Industry of the USSR. When the meter reflector antennas are installed on the roofs of high buildings, the communications range can reach 25 - 30 km.

Type IKM-12 (with an overall capacity of two line trunks of 264 channels) or IKM-30 (240 channels) equipment can be used as the multiplex equipment for the "Elektronika-M". In the first case, the KAMA RSLU [connector relay installations] are used for matching to the automatic telephone exchanges, while used in the second case are IKM-30 electronic matchers.

With the development of new switching equipment for telephone exchanges, the requirements placed on transmission systems for municipal telephone networks are also changing. The next generation of switching systems will be a quasi-electronic (KE) one. The functional signals can be transmitted between the KE and the ATS [automatic telephone exchange] in general for a given junction line trunk group of a signaling channel (OKS). In this case, the utilization of the junction line is increased, the need for signal channels in the transmission systems is eliminated, and the matchers for the channels are significantly simplified (and in a number of cases, are rendered unnecessary). Since the signal channels and matching devices in transmission systems comprise a substantial part of the equipment, it is expedient to create special variants of the equipment of transmission systems for the KE and ATS. These systems, in principle, can be both analog and digital. The choice should be made on the basis of an engineering and economic analysis.

Anticipated in the future is a transition to an integrated communications system, designed around digital switching and transmission systems. The long term promise of this trend is due, in particular, to the unity of the component base of the transmission, switching and computer equipment systems. With an increase in series production, prices for semi-finished products will decrease, and this will result in a stable decrease in the cost of systems and an increase in their reliability. For this reason, digital transmission systems for GTS's are already being developed at a fast pace.

In the immediate future, IKM-120 transmission systems, which differ from the IKM-30 in only the equipment of the line channel, since the terminal station is formed by combining four IKM-30's having standard matching units, will be employed for the creation of interexchange GTS junction lines, in addition to the IKM-30. The line channel is designed for MKS cable (a two cable circuit) with a repeater section length of 5 km. In this way, a trunk group of 960 channels can be created via two MKS 4 x 4 cables, i.e., twice as many as can be provided by the KAMA equipment. Drawbacks to the IKM-120 are the impossibility of operating it on the same cable with a KAMA system, and the necessity of using two cables for organizing communications service.

Anticipated for the more distant future is the development of the IKM-480 system for GTS's, the individual equipment of which will be similar to that of the IKM-30. This system is intended for coaxial cables, but will probably also be capable of operating via MKS cables with the multiplexing of one pair in a quad (a two cable circuit) including working in conjunction with a KAMA system.

The IKM-120 and IKM-480 systems will be capable of operating via a single cable circuit on balanced cables with shielded groups of pairs, which are being developed especially for digital transmission systems.

In step with the increase in the production of IKM [PCM] transmission systems, a considerable part of GTS equipment will be 30-channel digital channels -- either independent (IKM-30), or included in a complement of group channels of the highest orders. For this reason, an important problem is the efficient design of a network of digital channels: with display of the network condition, the organization of substitutions, through-working and combining and isolating the highest orders in the channels, as well as the organization of a service communications network, etc. All of this equipment should subsequently be incorporated in the integrated network.

Progress in engineering is making it economically advantageous to more widely employ the transmission systems in a GTS subscriber section. The use of inexpensive and reliable multichannel equipment for the creation of subscriber lines will permit a decrease in labor expenses and outlays for scarce materials. Foreign digital transmission systems are known for subscriber lines permanent fixing of the channels following the subscribers, as well as systems which incorporate switching elements, in which a group of subscribers (80 - 128) makes use of a common subscriber line group trunk (24 - 32 channels). The latter are more economical. Of the possible variants of digital systems, systems with delta modulation are extremely convenient, are less expensive and less susceptible to the influence of interference than PCM systems. The same digital channels as used for junction lines can be employed as the line channels.

The high information capacity of digital channels makes it possible to obtain channels for the remote control of subscriber sets, signaling, rerouting and substitutions in the case of breakdowns, as well as other automatic devices which simplify the operation and increase the quality of communications, with small expenditures.

At the present time, transmission systems for subscriber lines are designed for working with electromechanical and KE automatic telephone exchange systems. At the exchange, the subscriber signals are demodulated, converted to audio signals, and then switched. In this case, any method of coding is permissible in the transmission system (also including analog transmission).

With the introduction of electronic ATS's, it will be possible to realize the direct input of the subscriber digital flow to the exchange devices, without modulation. This will reduce the volume of equipment, however, the methods of coding the signals in electronic ATS's and the subscriber transmission system should be matched.

COPYRIGHT: Izdatel'stvo "Svyaz'", "Vestnik svyazi", 1977

8225
CSO:5500

UDC 621.396.67

THE KLA-600 AUTOMATED CONTROL UNIT FOR TU-600 AMPLIFIERS

Moscow VESTNIK SVYAZI in Russian No 9, Sep 77 pp 21-22

[Article by V.I. Neveykin, chief engineer of the production laboratory of the Leningrad Communications Production Engineering Administration: "What Does Local Automation of Amplifiers Provide?"]

[Text] A transition from the manual servicing to remote control of the numerous rural radio repeater units (RTU's) will permit an increase in their profitability. One of the conditions for the automation of an RTU is the existence of local automation for the amplifiers, which would meet modern technical requirements. The production laboratory of the Leningrad PTUS [Communications Production Engineering Administration] has developed the KLA-600 local automation complex for the TU-600 amplifiers. The application of the KLA-600 will provide for the organization of remote control of an RTU. Beginning in 1976, the equipment has been series produced in the pilot electromechanical shops of the Leningrad Oblast^t PTUS.

The local automation complex makes it possible to: turn on the amplifier when the "control" circuit is closed (in this case, the switching on takes place in the sequence set for the TU-600 amplifiers, where this sequence prevents the occurrence of an emergency situation), as well as turn it off when the "control" circuit is opened; automatically connect the load to the amplifier output after completing the "turn on" cycle and ground the load when the amplifier is cut off; protect the amplifier against overloads by switching the windings of the output transformer of the amplifier from 240 volts to 120 volts (when the plate current of the tubes of the output stage increases above the nominal level); cutoff and block the amplifier if the plate current of the output stage tubes exceeds the nominal value by 10 - 30%, the bias voltage is lost or the gain of the amplifier decreases by more than 6 dB; carry out the automatic, uninterrupted switching of sections of the autotransformer of the amplifier so as to maintain the voltage fed to the amplifier circuit within limits of $220 \pm 10\%$ volts for the case of fluctuations in the supply voltage of the power mains from 160 to 240 volts. The option of manually switching the sections of the amplifier autotransformer is not precluded.

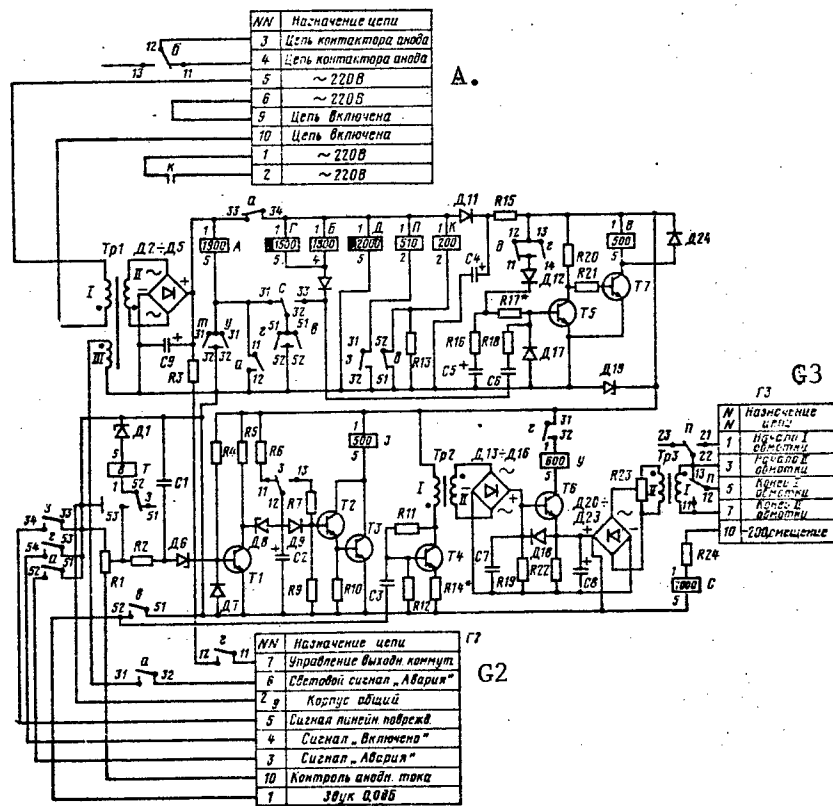

Figure 1. Basic schematic of the automation block.

- Key: A: NN. Circuit Designation;
- 3. Plate contactor circuit;
 - 4. Plate contactor circuit;
 - 5. 220 volts AC;
 - 6. 220 volts AC;
 - 9. Circuit switched on;
 - 10. Circuit switched on;
 - 1. 220 volts AC;
 - 2. 220 volts AC;
- G2: NN. Circuit designation;
- 7. Control of the output switcher;
 - 6. "Emergency" light signal;
 - 2, 9. Common chassis ground;
 - 5. Line fault signal;
 - 4. "Turned on" signal;
 - 3. "Emergency" signal;
 - 10. Plate current monitoring;
 - 1. 0.0 dB audio.
- G3: NN. Circuit designation;
- 1. Start of winding 1;
 - 3. Start of winding 2;
 - 5. End of winding 1;
 - 7. End of winding 2;
 - 10. -200 volts, bias;

The KLA-600 feeds out information on the switching-on of the amplifier, on line damage and disruptions. Information on the state of the TU-600 is fed out by the KLA-600 local automation by shorting the corresponding wire to the chassis (ground).

The KLA-600 unit consists of an automation block (BA), a block for switching the autotransformer sections (BPA) and a line switching block (BLK).

The automation block (figure 1) performs the function of controlling and monitoring the operation of the amplifier and consists of a rectifier, time delay and plate current monitor circuits, and comparison circuit and relay group which provides for the requisite commutation.

The turn-on cycle of the amplifier begins at the moment the circuit is made and the power mains voltage of 220 volts is applied to the primary winding of transformer Tr1. The rectified voltage from diode bridge D2 - D5 is fed to the windings of relays K and D. Then the relays V, as well as B and G, actuate sequentially.

After relay G is turned on (with a delay of 80 - 120 msec), the circuit for feeding the power to the comparison circuit is closed, the "amplifier on" signal is fed out, and the power voltage is fed to the BLK block to switch in the load (the repeater lines) to the amplifier output. In this case, transistor T5 is triggered, while T7 is cut off. Relay V drops out and opens the input circuit to the amplifier with contact 11-12. As a result, an audio signal is fed to its input. When the amplifier is turned on, the block automatically monitors its operation.

The bias voltage is monitored in the following manner. If during the turn-on cycle, the -200 volts bias voltage does not come from the amplifier, then the actuating circuit of relay A is closed and the circuit for holding in contactor relay K is broken with contact 33-34. After this, the power supply voltage is removed from the amplifier and the "emergency" signal is switched on in the display panel. If the bias voltage drops out during the time when the amplifier is operating, then the amplifier is cut off in a similar fashion.

The gain of the amplifier is controlled by a comparison circuit which is inserted in parallel with the input and output circuits of the amplifier. The amplifier stage of the gain monitor circuit is designed around transistor T4 with transformer Tr2 in the collector circuit. The input impedance of the stage is 15,000 ohms and the gain is 10 dB.

The comparison circuit is designed so that with the optimum gain of the amplifier, the voltage at capacitor C8 is greater than at capacitor C7. As a result, the current flows from capacitor C8 through diode D18 and resistor R19, producing a negative potential at the base of transistor T6 with respect to its emitter, something which reliably cuts it off. When the gain drops by more than 6 dB, transistor T6 cuts on, and relay Y in its collector circuit actuates, and after it, the emergency relay A. The amplifier is cut off and

blocked. Potentiometer R23 allows for setting the requisite response threshold of the circuit.

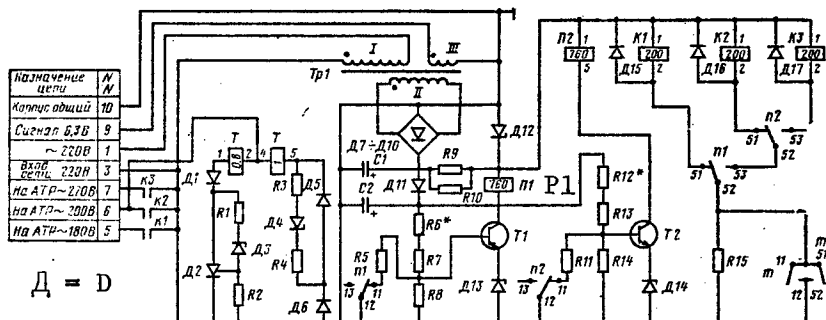

Figure 2. Basic schematic of the BPA [Block for switching the autotransformer sections].

- Key: NN. Circuit designation;
 10. Common chassis ground;
 9. 6.3 volts, signal;
 1. 220 volts AC;
 3. Mains input, 220 volts;
 7. 220 volts AC to the autotransformer;
 6. 220 volts AC to the autotransformer;
 5. 180 volts AC to the autotransformer.

Monitoring for amplifier overloading is realized in the following manner. If the plate current of the output stage of the amplifier does not exceed the nominal value, then the voltage fed from the wiper of resistor R1 is lower than the blocking voltage for reference diode D6, and the overload monitor circuit for the amplifier plate current is in its initial state: transistor T1 is turned on with the voltage fed to its base through resistor R4, while the voltage at its collector is lower than the blocking voltage for reference diode D8. The R2, C1 network protects the circuit against short term pulse interference. Transistors T2 and T3 are blocked, and relay 3 which turns on the overload signal is cut off. Capacitor C2 is charged through resistor R6. If the plate current exceeds the nominal level (the load on the amplifier output has increased with a short circuit on the line), then the monitor circuit actuates, as a result of which, contact 33-34 of relay 3 switches on the "line fault" signal. After 10 to 20 minutes, the circuit returns to the initial state, and if the plate current has not decreased, again actuates.

If following the reswitching, the plate current nonetheless exceeds the nominal level by 10 - 30%, then the voltage picked off of the wiper of resistor R1 will exceed the blocking threshold of reference diode D1, actuate relay T, and by means of contacts 31-32 close the actuating circuit for the emergency relay A. The amplifier is switched off.

The block for switching the autotransformer sections (figure 2) maintains the nominal electrical power supply voltage. The circuit which monitors the mains

voltage is designed around transistors T1 and T2, zener diodes D13 and D14, resistors R5 - R8, and R11 - R14 which form the base voltage dividers. Inserted in the collector circuits of transistors T1 and T2 are relays T1 and T2. The base circuits of the transistors are powered from the nonregulated rectifier output, something which permits monitoring the mains voltage. Diode D11 and capacitor C2 provide for additional filtering of the voltage feeding the base circuits of the transistors.

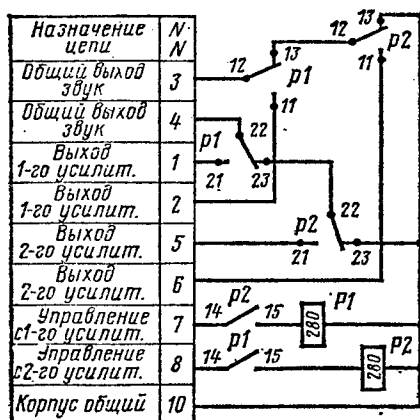

Figure 3. Basic schematic of the BLK [Line switching block].

- Key: NN. Circuit designation;
3. Common audio output;
 4. Common audio output;
 1. Output of the first amplifier;
 2. Output of the first amplifier;
 5. Output of the second amplifier;
 6. Output of the second amplifier;
 7. Control from the first amplifier;
 8. Control from the second amplifier;
 10. Common chassis ground.

When 220 volts is present in the mains, the voltage fed from the dividers to the bases of the transistors exceeds the blocking voltage of the zener diodes, inserted in the emitter circuits of the transistors, something which produces saturating base currents for transistors T1 and T2. Relays P1 and P2, inserted in the collector circuits, are in the turned-on state. In this case, the contacts of relay K3 close the circuit for the 220 volt section of the autotransformer for the 220 volt section of the autotransformer.

The circuit components are designed so that if the voltage in the mains drops down to 220 volts [sic], then transistor T2 cuts off, relays P2 and K3 drop out, and relay K2 actuates and closes the circuit for the 200 volt section of the autotransformer. The opposite response of relay P2 is possible only when the mains voltage increases by 8 - 10 volts (up to 208 - 210 volts), which reliably protects the circuit against unnecessary switching with small fluctuations in the mains voltage.

When the mains voltage drops to 180 volts, transistor T1 cuts off, relays P1 and K2 drop out, while relay K1 actuates and closes the circuit for the 180 volt section of the autotransformer. Transistor T1 again turns on, and relay P1 actuates only at a mains voltage of 188 - 190 volts.

Nondisruptive switching of the autotransformers sections is provided by a circuit designed around thyristors D2 and D5, diodes D1 and D6, zener diodes D3 and D4, and resistors R1 - R4. If the voltage fed to the circuit is less than 56 volts (one of the relays K1 - K3 is actuated), then the thyristors are in the turned-off state and current does not flow through the circuit.

If the voltage exceeds 56 volts (relays K1 - K3 do not actuate, and their contacts are open), then zener diode D3 or D4 conducts (depending on the incoming polarity at the given moment), and then D2 or D5 respectively, and the voltage supply circuit is completed through the thyristor to 200 volt section of the autotransformer. Diodes D1 and D5 protect the legs of the circuit against the opposite polarity. In this case, one half-period is completed through diode D1 and thyristor D2, while the second is completed through diode D6 and thyristor D5.

The line switching block (figure 3) provides for automatic connection of the load to the amplifier output when the "turn on" cycle is completed, and grounding of the load when the amplifier is switched off.

When the "turn on" cycle is completed for the first amplifier, relay R1 of the BLK block actuates, connecting the repeater lines to the output of the first amplifier. If the second amplifier is switched in, relay R2 actuates. The circuit provides for the connection of repeater lines only to that amplifier which was turned on first. When relays R1 and R2 drop out, the repeater lines are grounded.

The KLA-600 blocks are not structurally tied together. The BA and BPA are installed inside the amplifier cabinet, while the BLK, which is common to both amplifiers, is installed inside the output panel. Hookup cables for the connection of the BA and BPA blocks to the amplifiers.

The following are employed as the components in the KLA-600: P-307 silicon transistors; D223, D226G and D245 diodes; thyristors; D184A, D814D, D815E, D816A and D817A zener diodes; MBM and K50 capacitors; and RPN, MKU-48 and RKS-3 relays. Experience with the operation of the KLA-600 has shown that the equipment operates reliably and performs the specified functions.

COPYRIGHT: Izdatel'stvo "Svyaz'", "Vestnik svyazi", 1977

8225
CSO:5500

UDC 383/384

STIMULATING A GROWTH IN LABOR PRODUCTIVITY

Moscow VESTNIK SVYAZI in Russian No 9, Sep 77 pp 26-27

[Article by N.S. Berinashvili, post-graduate student at the All-Union Correspondence Electrical Engineering Institute for Communications]

[Text] It was underscored in the "Main Developmental Trends of the USSR National Economy During 1976 - 1980" that it is necessary in the 10th Five-Year Plan to "concentrate particular attention on stepping up the growth in labor productivity, which is a crucial condition for the further development of production and an increase in the welfare of the populace. Some 85 - 90% of the increase in the production of the national income is to come from an increase in labor productivity." Analyzed in this article are data on the increase in labor productivity during the past five-year plan in the management of the nation's communications, and a method of stimulating an increase in this indicator, as well as a procedure for computing the accepted standards for allocations to the material incentive fund arising from the increase in labor productivity.

An important factor in increasing the effectiveness of public production is the complete utilization of the advantages of the new system of management. There is no doubt that the enterprise where material and moral incentives are the most completely and skilfully combined, a progressive labor payment system is employed, and where bonus systems are developed taking the stimulation of a growth in labor productivity into account, can achieve great successes in production activity.

An analysis of data on the growth of labor productivity over the Ninth Five-Year Plan (1971 - 1975) as a whole for the management of the nation's communications attests to the fact that 71.9% of the increase in communications production was due to an increase in this indicator. A high percentage of the increase in production volume was achieved by virtue of an increase in labor productivity at the communications enterprises of Estonia (82.8%) and Latvia (82.5%). However, it is impossible to mention this without citing the communications enterprises of a number of other union republics, where the

magnitude of this percentage fluctuated from 55.3 to 68.5% (55.3% for Lithuania, 55.8% for the Turkmen Republic, 59% for the Georgian Republic, 59.2% for the Kirghiz Republic, 60.9% for the Tadzhik Republic, 62.3% for Armenia and 62.5% for Azerbaydzhan). Such a situation is explained by the fact that in these republics during the Ninth Five-Year Plan, the rate of growth in the number of workers significantly exceeded the average rate of growth of their numbers as a whole in the communications industry, as well as by somewhat of a reduced level of attention to the labor productivity indicator.

Indicators Показатели	According to Plan По плану	1. По предлагаемой методике	2. Отклонение	
			по абсолютной величине	в %
			3.	in % of %
4. Общая сумма прибыли, млн. руб.	25,9	26,3	+0,4	+1,5
5. Объем продукции связи, млн. руб.	77,2	77,2	—	—
6. Эксплуатационные расходы, млн. руб.	58,69	58,29	-0,4	-0,7
7. Производительность труда, руб.	2847	2876	+29	+1,0
8. Численность работников связи, чел.	27 116	26 842	-274	-1,1
9. Сумма фонда материального поощрения, тыс. руб.	2303	а) 2326 б) 2337,5 в) 2349	+23 +34,5 +46	+1,0 а) +1,5 б) +2,0 в)

- Key: 1. In accordance with the procedure proposed here;
 2. Deviation;
 3. In terms of the absolute magnitude;
 4. Overall income total, millions of rubles;
 5. Production volume in communications, millions of rubles;
 6. Operational expenditures, millions of rubles;
 7. Labor productivity, rubles;
 8. Number of communications workers, persons;
 9. Total of the material incentive fund, thousands of rubles.

Taking into account the crucial significance of a growth in labor productivity for increasing the effectiveness of public production, the directive organs in Ninth Five-Year Plan adopted the resolution that at the enterprises of the industry, this indicator should be approved from above and be a fund determinant. In the basic regulations for the generation and expenditure of incentive funds in 1976 - 1980, approved in the first days of December, 1976, it was stated, "Assignments as regards the growth in labor productivity should be incorporated in the fund determining indicators . . ." (EKONOMICHESKAYA GAZETA, 1976, No. 50).

Not so long ago the Interdepartmental Commission of the USSR Gosplan on questions of the application of new methods for planning and economic stimulation adopted a special resolution (of 31 March, 1977), in which it was proposed

that the USSR Communications Ministry conduct an experiment during 1978 - 1980 in a number of communications production engineering administrations and enterprises, the purpose of which is to study whether it is possible in communications management to establish in the fund determining indicators an indicator for "the growth in labor productivity", computed with a consideration of the specific operational features of the enterprises.

The experiment will consist in employing, along with two established fund determining indicators ("tariff proceeds (income)" and "the level of profitability"), a "growth in labor productivity" indicator. Moreover, assignments for the growth in labor productivity according the years of the five-year plan should be established in the plan.

To carry out the experiment indicated here, it is necessary to develop a procedure for stimulating the growth in labor productivity, as well as perform the calculation of the accepted standard for allocations to the material incentive fund. In working out the standard for the allocations due to the growth in labor productivity, to be taken into account is the fact that the growth rates of the FMP [material incentive fund] should not run ahead of the income growth rate, i.e., one must primarily proceed on the basis of national economic interests. Only when this condition is met will a further increase in the efficiency of the communications sector be achieved.

Consequently, it is required that the standard for allocations to the FMP be computed for each percent of growth in labor productivity in comparison with level provided for in the five-year plan, and it is also necessary to determine to what extent this standard influences an increase in income, a reduction in operational expenditures, and finally, a growth in the total for the material incentive fund.

To calculate the standard for allocations to the FMP, adopted as the initial data are those of the Communications Ministry of the Georgian SSR, and specifically, the indicators provided for in the 1978 plan: The overall income total -- 25.9 rubles; the communications production volume (Q) -- 77.2 million rubles; operational expenditures -- 58.69 million rubles; the total for the material incentive fund -- 2.303 million rubles; labor productivity (P_t) -- 2,847 rubles; the communications work force (R) -- 27,116 persons; and the average annual wage of one worker -- 1,365 rubles.

An increase in labor productivity by 1% provides for bringing the product output of one communications worker in 1978 up to 2,876 rubles. Working from this output level, we compute the number of workers necessary for an increase in labor productivity of 1%:

$$R_{78} = Q:P_t = 77,200,000:2,876 = 26,842 \text{ people}$$

Then the savings in the work force (R_{ek}) which can be achieved by virtue of the increase in labor productivity, and correspondingly, the savings in operational expenditures (E_{ek}):

$$P_{ek}[\text{sic}] = 27,116 - 26,842 = 274 \text{ people}$$

$$E_{ek} = (274 \times 1,365):5.3/100 = 393.8 \text{ thousand rubles}$$

The amount of the total income will, at a minimum, be increased by the sum indicated here.

The results of the calculations are given in the table. The size of the FMP is given in the solution variants.

If the standard for allocations to the FMP arising from a 1% growth in labor productivity is taken as 1.5% (at the level of the increase in income), then the total for the FMP for the communications enterprises will increase by 34,500 rubles. This will increase the material interest of the communications workers in the results of their own labor. Production efficiency will increase, since a significant savings in operational expenditures (393.8 - 34.5 = 359.3 thousand rubles) will be used to expand reproduction.

At the same time, it is apparent from the calculation that it is impossible to adopt a standard for allocations in the amount of 2% for each percent increase in labor productivity, since in this case, the rate of growth of the material incentive fund will lead to the rate of growth in income.

The application of the procedure proposed here, in our opinion, will provide for an increase in the efficiency of the communications sector.

COPYRIGHT: Izdatel'stvo "Svyaz'", "Vestnik svyazi", 1977

8225
CSO:5500

BRIEFS

TASHKENT-ANDIZHAN RADIO RELAY--The new radio relay transmission line from Tashkent to Andizhan has secured the reception of two color TV programs for the Fergana Valley. In the future, it will also be used for the international telephone and telegraph network. [Moscow Domestic Service in Russian 1430 GMT 7 Dec 77 LD]

TELEVISION BROADCASTS IN TADZHIKISTAN--Television has reached the mountain regions of Ayni and Leninskiy rayons, Tadzhikistan. The construction of transmitters and television towers has been completed, and they now relay programs from central television and Dushanbe and Tashkent television studios. [Moscow Domestic Service in Russian 0900 GMT 4 Dec 77 LD]

VLADIMIRSKAYA TV RETRANSMITTER--Vladimir--The antennas of all sets in the oblast are being realigned on a new television center constructed near the city of Budogda. Here the tower of a retransmitter has risen to 331.7 meters. [Text] [Moscow IZVESTIYA in Russian 25 Nov 77 Morning Edition p 4 LD]

RAYCHIKHINSK, AMURSKAYA TV STATION--Blagoveshchensk--The antenna of a powerful television station which has just been constructed in the city of Raychikhinsk has soared to a height of almost 200 meters. It has begun relaying transmissions from central television and the Blagoveshchensk studio. [Text] [Moscow SEL'SKAYA ZHIZN' in Russian 25 Nov 77 p 4 LD]

CSO: 5500

INTERNATIONAL AFFAIRS

BRIEFS

ITALIAN-PORTUGUESE AGREEMENT--Rome, 6 Dec (ANSA)--The Italian news agency "ANSA," and the Portuguese news agency, "ANOP," have signed a cooperation agreement here for a wide-ranging exchange of news services and photographs. The agreement was signed during a visit here of "ANOP" directors Joao Tito de Morais and Eduardo Corregedor da Fonseca [names as received]. The two agencies will swap their domestic services, foreign services and photographs on a regular basis, as well as supplying journalistic or photographic services on request. The agreement is based on full reciprocity between the two agencies, so there are no financial implications apart from the pure and simple reimbursement of the costs of exchanging some services. [Text] [Rome ANSA in English 1550 GMT 6 Dec 77 AU]

CSO: 5500

DIGITAL IMAGE PROCESSING SYSTEM DESCRIBED

Milan ALTA FREQUENZA Vol 46 No 1 Jan 77 pp 6-11

[Article by A. D'Amore, L. Delcaro, R. Mottola, G. Sicuranza, of the Institute of Electrical Engineering and Electronics, University of Trieste: "A System for Image Processing with a Minicomputer"; manuscript received 15 Nov 76]

[Text] The system for image processing with a minicomputer, devised in the Institute of Electrical Engineering and Electronics of the University of Trieste, is described in this paper. The block diagrams of the image acquisition and visualization circuits constructed by us and the principal processing programs available at present are described in particular. The examples given make it possible to evaluate the performance of the system from the point of view both of image quality and of computing time.

Introduction

An image processing system using a 32-kiloword storage with a 16-bit mass magnetic disk memory is described in this paper. In this system, the images, which may be on opaque or transparent backing, are picked up by means of a television camera and are digitized by a sampling device to be described below. After processing, the images can be sent to a display or to a print-out unit. The features of our system are mostly associated with the choice of a minicomputer as a means of processing. This choice is justified by the need for not using excessively expensive instruments, but, rather, an instrument capable also of handling large amounts of data, as happens in the field of images. Present minicomputers, in fact, make it possible to achieve this objective, if they are combined with efficient mass memories, like, precisely, the modern magnetic disk units. It must be pointed out, however, that there are still some limitations with this kind of computer systems, including primarily, certainly, the low speed of transfer of data between the main unit and the peripheral units. In our case, with regard to input, this involved the need for acquiring the complete image in several televised frames and for the output, choice of a long-persistence phosphor cathode ray tube, in order not to have to regenerate the image too many times a second. The system worked out

makes it possible to collect the images with a number of dots equal to 375,000 (625 X 600) and to display them in blocks that also have 262,144 dots (512 X 512), that is to say, slightly less than the ones picked up.

In order to be able to process these images in reasonable times, it was necessary to resort to the most efficient processing methods available at present and, at the same time, to structure the programs in such a way as to make maximum use of the system. This resulted in a set of programs arranged in modules to limit as much as possible the number of data transfers between main memory and mass storage. Some of these data, especially the data implementing the most critical parts of the computation algorithms were written in ASSEMBLER language, in order to obtain considerable reductions in execution times. At present, image processing with our system can be performed by using linear techniques, like the Z transform or the Fourier transform, or nonlinear, like equalization, compression or expansion of the gray levels. Since the possibilities offered by the various methods are already known, we shall restrict ourselves, in this paper, to making a brief description of the programs developed by us, indicating the times obtained with various types of processing for the purpose of making possible an accurate evaluation of the efficiency of the system worked out. In order to be able also to give an exact idea of its other characteristics, some examples are given with various numbers of dots (128 X 128, 256 X 256 and 512 X 512), pertaining to specific monoscopes on disk, in order to be able to judge the quality of reproduction. Other examples pertain to pickups made with a television camera and make it possible to evaluate the performance of the entire processing system.

The Image Sampling and Displaying Device

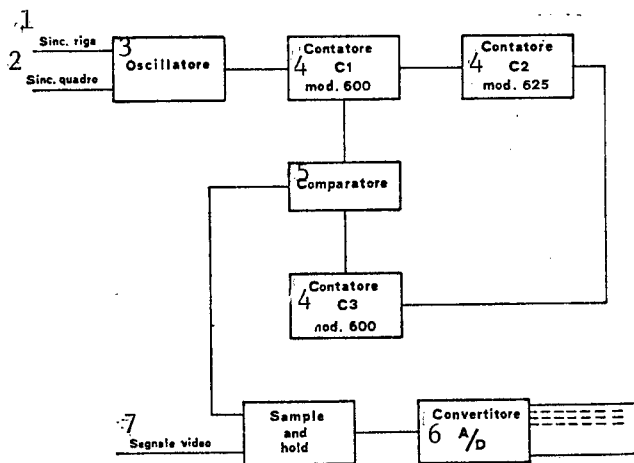

Figure 1. Block diagram of the acquisition and sampling device.

Key: 1. line sync; 2. frame sync;
3. oscillator; 4. counter; 5. comparator;
6. analog-digital converter;
7. video signal

As was already stated in the introduction, the televised image is subdivided into 625 X 600 dots, in other words, in 625 lines and 600 columns. In view of the limited speed of transfer of data between the minicomputer and the peripheral units, it was not possible to sample the televised signal, in order to acquire the whole image in one frame. Then, provision was made for performing the operation in 600 frames by acquiring one column of the image for each frame, since, in that way, it proved to be possible to record the data directly on the disk. In order to have an idea of the operation of the device, reference should be made to the block diagram in figure 1 in which the basic parts forming the acquisition circuit are shown. Once the system has been started, the operations begin when, at coincidence between the line pulse rising leading edge and the frame pulse leading edge, the oscillator whose frequency is determined in order to obtain a 600-dot per line sampling is gated. Dot counting is performed by counter C_1 , which makes line counter C_2 advance, which in turn controls frame counter C_3 . The comparator placed between C_1 and C_3 furnishes sampling control when there is equality between the states of the dot counter and of the frame counter, thus ensuring acquisition of one column for each frame. Actual sampling of the televised signal is performed by the sample and hold circuit, which controls the 8-bit analog-digital converter (256 gray levels). The oscillator is locked by a stop clock pulse whenever counter C_1 has counted 600 pulses and it is started up by the next line pulse. Acquisition ends when counter C_3 has counted 600 frames by means of an appropriate total stop pulse that locks the input circuit and makes the whole system ready for the next acquisition. Acquisition operations can be supervised by the monitor, because a special circuit intensifies the brightness of the dots as they are being sampled (11).

The image picked up or processed is visualized on a cathode ray tube with long persistence phosphors in view of the impossibility of regenerating with a frequency sufficient for television-type phosphor tubes. The data pertaining to the image under examination are sent from the computer to the display by means of a standard MCI interface (HP 12.566 B, microcircuit interface) and a circuit constructed by us. This circuit was designed to use the maximum speed of data transmission and it handles automatic visualization of the three formats provided (128 X 128, 256 X 256 and 512 X 512 dots). More especially, as can be seen from the block diagram in figure 2, the clock that provides the coordinates of the dot to be visualized by means of the line dividers CR and the frame dividers CQ and the pertinent digital-analog converters is started by means of a start signal sent by the microcircuit interface. Counters CR and CQ are readied for counting with modulo 2^7 , 2^8 , 2^9 by means of a logic network controlled by the program that handles the output operations. On completion of line counting, the clock is stopped for 200 microseconds by monostable device M1 making it possible for the beam to return. At the end of each monostable frame, M2 acts on bistable FFI furnishing the stop signal.

At the same time, a signal CM with a frequency half that of clock CT is used to transfer data from the computer to the output buffer of the microcircuit interface and it acts, together with signal CT, on the demultiplexer for data selection. In fact, it must be borne in mind that, in order to attain the maximum

possible speed, provision has been made for uniting in one single (16-bit) word the gray level values of two adjacent dots for which, as has been said, only 8 bits (256 levels) are sufficient. The need for furnishing the digital-analog converter of the Z axis, subsequently, the information contained in the first 8 bits (0-7) and in the eight remaining bits (8-15) stems from this.

It should be pointed out that special connections are not used for the reset and for proper preparing of the counters for counting the three formats provided for, but, rather, three of the 16 data-output lines of the microcircuit interface buffer are utilized. In fact, because these signals are not simultaneous with data transmission, it is possible, when the clock is stopped, to activate, by means of the bistable multivibrator FFI, three gates that enable the control pulses to pass through.

Finally, it should be noted that the output signal of the Z-axis digital-analog converter is amplified before sending it to the cathode ray tube and a constant voltage is added to it, in order to make maximum use of the dynamics of the display. This voltage is set at zero when the beam is stopped, in order not to damage the phosphors.

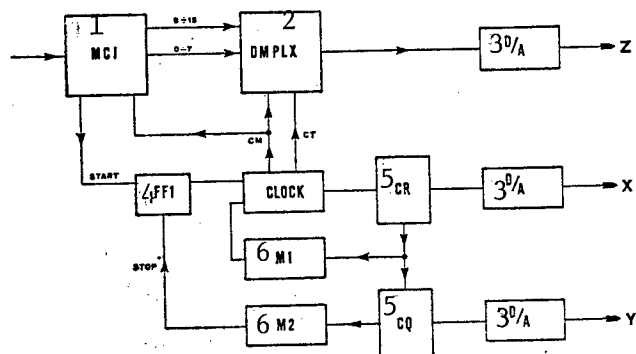

Figure 2. Block diagram of the visualization circuit.

Key: 1. standard interface; 2. demultiplexer; 3. digital-analog converter; 4. bistable multivibrator; 5. counter; 6. monostable device

Processing Programs

Numerous processing programs written for a 32-kiloword 16-bit storage minicomputer were developed. Some of them make linear processing (Z transform and Fourier transform) possible and others, nonlinear processing (equalization of the histograms, expansion of the dynamics of the grays, and so on) [1 ÷ 6].

With regard to processing with the Z transform, the following algorithm was implemented:

$$(1) \quad y(m,n) = \sum_{i=1}^{N_1} \sum_{j=1}^{N_2} a_{ij} x(m-i+1, n-j+1) - \sum_{i=1}^{M_1} \sum_{j=1}^{M_2} b_{ij} y(m-i+1, n-j+1)$$

$$i+j \neq 2$$

in which x and y indicate the values of the matrices of the input and output data (gray levels of the original image and the processed image), a and b are the coefficients of the filter used whose order is determined by N_1 , N_2 , M_1 , M_2 . The program worked out on this basis may require filtering on matrices 128 X 128, 256 X 256, 512 X 512 with floating-decimal arithmetic when N_1 , N_2 , M_1 , M_2 are ≤ 10 for the first two formats and \leq for the 512 format. Calculation of the output begins from the upper left corner of the input matrix when null initial conditions are chosen both for the output matrix and the input matrix. Subsequent filtering starting from the lower right corner of the image makes it possible also to obtain, with IIR filters, null phase transfer functions. This second processing is performed on the image obtained after the first filtering cut off on the dimensions of the standard format. A number of tests made with delay filters justify this approximation, since the error owing to the cutting off turned out to be small, in most of the cases examined, a few lines from the edge.

The impossibility of storing the input and output matrices entirely in memory makes it necessary to require processing in successive steps, operating on blocks that turn out, with the present sizing, to consist of eight lines for the 128 X 128 and 256 X 256 formats and four lines for the larger format. At every step, the data forming the initial conditions for the next block are stored in memory automatically. The program also provides for storing the blocks of data already processed on a magnetic disk and for requiring 180° rotation of the image, in order to be able to perform the second filtering required for having null phase with the same algorithm (1). In a first version, the program was worked out in FORTRAN IV and organized in such a way as to reduce the times required for identification of the components of the matrices to be handled at each step. Subsequently, in order to reduce the processing times further, three routines in ASSEMBLER were introduced with the tasks of transferring data between magnetic disk and storage, of processing the individual block of data and of restoring the initial conditions for the next block. An approximately fourfold reduction in calculation times was obtained with this last version in comparison with the initial version. In order to demonstrate the efficiency of the program, the processing times (in seconds) for filtering performed on the three formats are given in table 1. As can be seen from the table, these times depend linearly on the number of dots in the image (D) and on the number of filter coefficients (N) in accordance with a formula like the following:

$$T = P \cdot D \cdot (0.246 + N \cdot 0.0472)$$

in which P equals 2 or 1 depending on whether or not the second filtering is performed.

Table 1. Processing Times (in seconds)
for Filterings Performed with IIR Filters
on the Three Image Formats

D		N				
		2	8	18	32	50
128 × 128	$P = 1$	17	26	41	63	91
	$P = 2$	29	48	79	121	177
256 × 256	$P = 1$	43	80	142	227	337
	$P = 2$	81	155	279	449	669
512 × 512	$P = 1$	162	314	560	902	1338
	$P = 2$	319	623	1115	1799	2671

The filters used may be infinite impulse response (IIR) or finite impulse response (FIR). In this case, relation (1) is applied, disregarding, however, the second summatory doublet.

With regard to determination of coefficients a and b of the filter, two procedures are available. A first method (9) consists in calculating the bidimensional filter as the product of two monodimensional cells, designed on the basis of specifications supplied in the field of frequency, in accordance with the criterium of maximum flatness (Butterworth) or of preset wave pattern (Chebyshev). In both cases, it is possible to establish the complexity of the filter or the gain on band and outside band together with the width of the transition zone. The structures produced are of the low-pass or high-pass type. The use of cells obtained by 45° rotation in the frequency plane is also provided for, in order to improve the circular symmetry of the bidimensional filter.

On the other hand, a second method makes it possible to optimize the modulo and phase of the bidimensional filter directly on the basis of predetermined specifications in the field of frequencies (10). In this case, it is possible to impose symmetry and also, in simple cases, stability of the filters themselves by means of suitable links.

In addition, it has been possible for some time now to perform processing with the Fourier rapid transform technique. Although this method does not make it possible to obtain calculation times as short as with the use of recursive digital filters, it is proving, however, to be still useful because of the simplicity with which the filter mask intended to be used can be simulated. Processing programs based on the use of the FFT have already been described fully in previous articles (7,8), in which the calculation times obtained are also given.

Concerning the techniques for nonlinear processing, at present we have some programs available that make it possible to equalize the histograms of the gray levels of the image and to expand (or compress) the dynamics around a predetermined level, possibly reducing quantization on the basis of the 256 values provided for in the input. These programs proved to be useful in many applications and can be used very easily also in conjunction with programs performing linear filtering.

Programs for Controlling Input/Output Operations

Operations for image acquisition and for representation on display are controlled by two programs in ASSEMBLER, which control the outside circuits of the two devices by using the microcircuit interface recognized by the computer as input-output channel. These programs use the interruption system and a fast-access channel to the main memory for writing and reading from disk, in order to be able to perform data transfers at the required speed and to synchronize the computer with the external clocks (input and output video signal). Therefore, by their nature, they are incompatible with the system operating with disks (DOS III), which does not allow the programmer to use input-output instructions. Nevertheless, in order not to abandon the convenience of using the programs within the sphere of an operational system, several expedients were adopted that paralyze the operational system itself at the beginning of the acquisition and display operations, restoring it at their conclusion. This is achieved by adding a routine at the head of the program that neutralizes the system's protections, retains their core resident part and alters the memory zone reserved for control of interrupts by introducing the instructions needed for developing the program. At the end of the operations, another routine restores the initial state of the memory and of the interruption system, enabling the DOS to resume control.

In particular, the acquisition program uses two buffers that are filled alternately with the data acquired on request of an interrupt coming every 64 microseconds from the sampling circuit. Immediately after the first buffer is filled, the data are transferred on the disk by means of the DMA, while the second buffer begins to be filled. A similar method is also used in the program making it possible to send the data to display. In this case, however, some special expedients required by the presence of an external clock controlling the visualization operations had to be implemented, in order to attain the maximum repetition speed of the image. The clock frequency was selected by taking into account the transmission capabilities of the system, in order to represent the three formats provided for satisfactorily on the display. This affects the structure of the program and sends data outside, since, in any state, the computer has to respond to the request for new data by the clock in time shorter than a semiperiod. This linkage turns out to be especially burdensome, since account must also be taken of the decreased efficiency of the CPU [Central Processor Unit] in the presence of reading and writing operations performed with the aid of the DMA. It should be pointed out, among the peculiarities of this program, that it is structured in such a way as to modify itself when the data of an image are exhausted, in order to be able to recommence operations of data transmission, regardless of the format, in the above-indicated time

interval. In fact, since it is possible to transfer a maximum of 6,144 data at a time (one trace) from the disk into storage and since the dots for the formats selected are not a multiple of that number, it is necessary to identify the last dot of the image within the sphere of these 6,144 data. This identification cannot be done by means of simple analyses, in view of the excessive time that they require, but, rather, with expedients of the type adopted by us, unless it is acceptable to reduce the image regeneration frequency.

By structuring the programs in this way, image scanning times of 0.6 second for the 128 X 128 format, 2.5 seconds for the 256 X 256 format and 10 seconds for the 512 X 512 format were obtained.

Examples

Some photographs picked up and processed with our system are commented on in this section. These photographs were obtained directly from the display with slow scanning, using an operation provided by the image-forming program. The pickup conditions, photographic material and processing used are the same for all the images presented here.

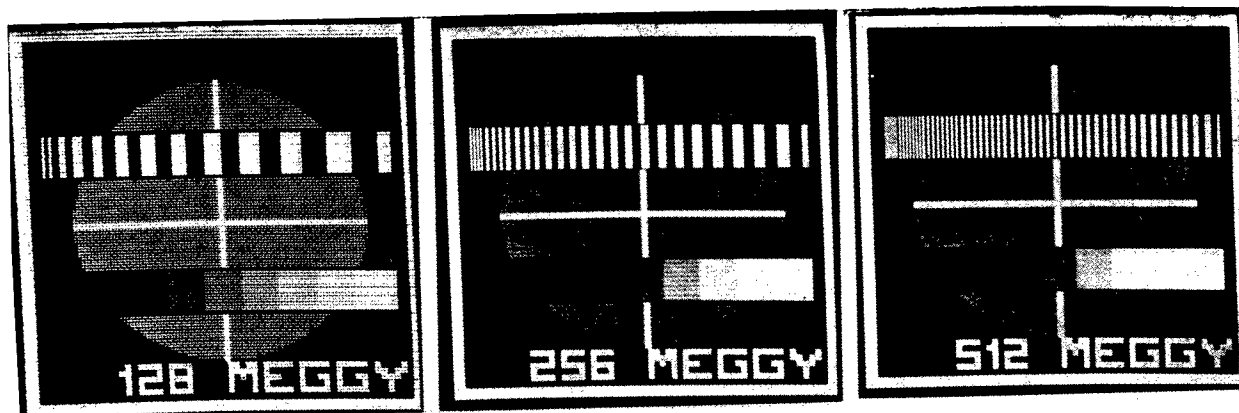

Figure 3. Monoscopes with 128 X 128, 256 X 256 and 512 X 512 dots.

Figure 3 shows three monoscopes (generated with an appropriate program) that make it possible to evaluate the performance of the single visualization system, constructed respectively with 128 X 128, 256 X 256 and 512 X 512 dots. The image consists of a circle with a cross in the center, a series of black and white lines spaced increasingly and a scale of eight grays. It was designed for the purpose of making it possible to calibrate the output circuits easily and to evaluate the performance of the system immediately both with regard to definition and to the dynamics of the levels. In addition, each monoscope can be used successfully in studying the behavior of the filters. Comparison of the three images gives an immediate idea of the improvement achieved by increasing the number of dots. It can be observed that the image constructed with 256 X 256 dots is already judged by the eye of sufficient quality for most practical cases, while the one with the smaller number of dots (the first one) shows the accuracy of positioning of the electronic beam.

Figure 4. Blurred image and restored image.

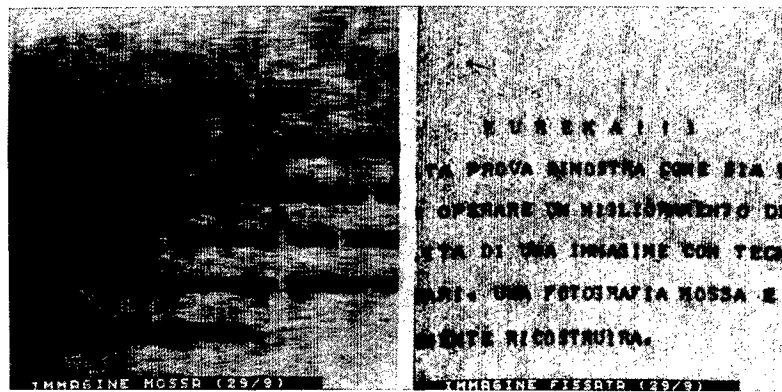

Figure 5. Original image and processed image.



The second example (figure 4) gives a rather obvious idea of the possibility of restoring the information content of a blurred image with an appropriate IIR digital filter. In fact, it can be observed that all the letters in the second image are legible, differently from what is true of the first image. In this case, the original image was picked up with a television camera and it makes it possible to evaluate the resolution of the complete system for the 256 X 256 format.

The most significant example is, without question, the one in figure 5, both because it is for the maximum possible format (512 X 512) and because the second image was obtained with the combined use of several techniques, especially with high-pass filtering and equalization. It can be noted that, in this way, on the one hand a more balanced image was obtained with regard to the various gray levels, and, on the other hand, some details are visible that could barely be made out in the original image (profile of the face, ear, hair, and so on).

In figure 6, an application of the techniques described to the field of medicine is shown. In particular, in this case, a better definition was achieved of the outline of a liver cyst with low-pass preliminary filtering to reduce the high-frequency noise, equalization of the histogram and reduction to 16 levels.

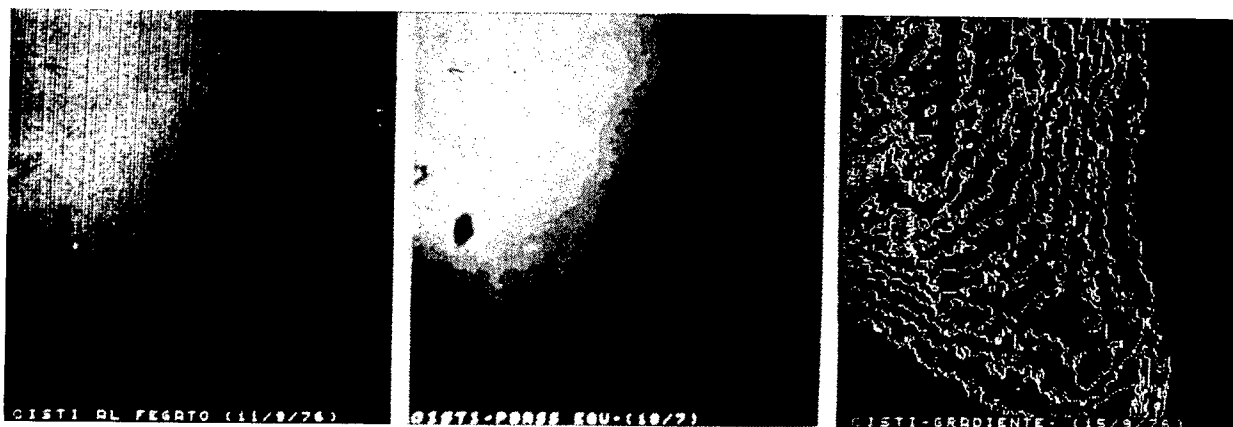

Figure 6. Liver cyst: original, image with 16 gray levels, extraction of outlines of constant density areas.

By using this last image, it was possible to extract only the edge lines of the constant gray level zones by using a bypass filter.

Results were obtained with the above-described system in the field of ophthalmology in estimating the diameter of the retinal vessels. It was especially possible to measure the variation of a section of those vessels in patients subjected to the action of vasodilating and vasoconstrictive drugs (12), (13). At present, similar work is being performed in collaboration with the Radiology Institute of the University of Trieste on the renal arteries for the purpose of being able to diagnose possible hypertensions. In all these cases, high-pass filters are used, in order to make the outlines more visible and expansions of the gray dynamics are performed by recording the images on print-out at the end.

Conclusions

The image processing system with a minicomputer developed in the Institute of Electrical Engineering and Electronics of the University of Trieste has been described in this paper. This system has already been used for some time for research conducted in collaboration with the Radiology Institute and the Ophthalmology Clinic of the university. The results obtained so far are positively encouraging and justify continuing the activity undertaken in the biomedical field. Experience already acquired has shown, on the one hand, the advisability of developing processing techniques worked out on the basis of specific problems, and, on the other hand, the desirability of extending the system, in order to have the capability of using color.

BIBLIOGRAPHY

1. Andrews, H. C. "Computer Techniques in Image Processing," New York and London, Academic Press, 1970.

2. PIEEE, Special issue on digital picture processing, Vol 60, No 7, July 1972.
3. TRANS. ON COMPUTERS, Special issue on digital image processing, Vol C 23, No 5, May 1974.
4. TRANS. ON CIRCUITS AND SYSTEMS, Special issue on digital filtering and image processing, Vol CAS-22, No 3, March 1975.
5. PIEEE, Special issue on digital signal processing, Vol 63, No 4, April 1975.
6. Gold, B., and Rader, C. M. "Digital Processing of Signals," New York, McGraw-Hill, 1969.
7. Delcaro, L., and Sicuranza, G. "A Program for Processing Images with a Minicomputer," ALTA FREQUENZA, Vol 43, No 8, August 1974.
8. Delcaro, L., and Sicuranza, G. "A Method for Transposing Externally Stored Matrices," IEEE TRANS. ON COMPUTER, Vol C-23, No 9, September 1974.
9. Mottola, R. "System for Processing Images Developed on the Basis of the Z Transform," doctoral dissertation, Institute of Electrical Engineering and Electronics, University of Trieste, 1975-1976 academic year.
10. Delcaro, L., and Sicuranza, G. "Limited Optimization of Bidimensional Recurrent Digital Filters," TECNICA ITALIANA, in process of publication.
11. D'Amore, A., Delcaro, L., and Sicuranza, G. "A Digital Image Acquisition and Processing System," Internal Report No 61 of the Institute of Electrical Engineering and Electronics of the University of Trieste, April 1974.
12. Brancato, R., D'Amore, A., Delcaro, L., Ravalico, G., and Sicuranze, G. "An Attempt Towards a New Technique for the Computer Analysis of Fluorescein Angiography," BULLETIN OF THE HELLENIC OPHTHALMOLOGICAL SOCIETY, Vol 43, 1975.
13. Brancato, R., Delcaro, L., Ravalico, G., and Sicuranza, G. "The Computerized Elaboration of Fluoroangiographic Data on Retinal Vasculari- zation," European Congress on Fluoroangiography, Ghent, 24 March-1 April 1976.

10,042
CSO: 5500

- END -