

REPORT DOCUMENTATION PAGE

Form Approved
OMB No. 074-0188

Public reporting burden for this collection of information is estimated to average 1 hour per response, including the time for reviewing instructions, searching existing data sources, gathering and maintaining the data needed, and completing and reviewing this collection of information. Send comments regarding this burden estimate or any other aspect of this collection of information, including suggestions for reducing this burden to Washington Headquarters Services, Directorate for Information Operations and Reports, 1215 Jefferson Davis Highway, Suite 1204, Arlington, VA 22202-4302, and to the Office of Management and Budget, Paperwork Reduction Project (0704-0188), Washington, DC 20503

1. AGENCY USE ONLY (Leave blank)	2. REPORT DATE 21 March 2000	3. REPORT TYPE AND DATES COVERED Symposium Paper 21-23 March 2000	
4. TITLE AND SUBTITLE A Structured Approach to the Articulation of Future Mine Countermeasure Concepts		5. FUNDING NUMBERS	
6. AUTHOR(S) Daniel E. Harris and Don W. Shepherd			
7. PERFORMING ORGANIZATION NAME(S) AND ADDRESS(ES) Naval Surface Warfare Center Coastal Systems Station 6703 West Highway 98 Panama City, FL 32407		8. PERFORMING ORGANIZATION REPORT NUMBER N/A	
9. SPONSORING / MONITORING AGENCY NAME(S) AND ADDRESS(ES) Naval Surface Warfare Center Dahlgren Division 17320 Dahlgren Road Code N10 Dahlgren VA 22448-5100		10. SPONSORING / MONITORING AGENCY REPORT NUMBER N/A	
11. SUPPLEMENTARY NOTES Prepared for the Engineering the Total Ship (ETS) 2000 Symposium held in Gaithersburg, Md. at the National Institute of Standards & Technology and sponsored by the Naval Surface Warfare Center & the American Society of Naval Engineers			
12a. DISTRIBUTION / AVAILABILITY STATEMENT Approved for public release: Distribution is unlimited			12b. DISTRIBUTION CODE A
13. ABSTRACT (Maximum 200 Words) This paper presents an approach to developing a structure derived from the point of view that mine countermeasures is a core Navy function independent of whether dedicated or organic systems and platforms perform that function. It is an appreciated fact that mine countermeasures is a complex warfare task that will play an increasingly important role in naval operations as the Navy continues to implement the littoral warfare strategy. In the past, mine countermeasures was regarded primarily as operations undertaken by specialized naval components independent of the main battle force components. In the future, implementation of the naval strategy will require an expanded view of mine countermeasures. The main battle force components will be required to possess organic capabilities to deal with the treat of mines through a cooperative engagement capability approach. This paper focuses on articulating an overall framework that can be regarded as the point of departure toward defining and implementing a mine countermeasure capability fully compatible with, and integrated into, fleet operations.			
14. SUBJECT TERMS Mine Warfare; Architecture			15. NUMBER OF PAGES 10
			16. PRICE CODE
17. SECURITY CLASSIFICATION OF REPORT UNCLASSIFIED	18. SECURITY CLASSIFICATION OF THIS PAGE UNCLASSIFIED	19. SECURITY CLASSIFICATION OF ABSTRACT UNCLASSIFIED	20. LIMITATION OF ABSTRACT UL

NSN 7540-01-280-5500

Standard Form 298 (Rev. 2-89)
Prescribed by ANSI Std. Z39-18
298-102

AQ 400-07-1841

Daniel E. Harris, Donald W. Shepherd
**A Structured Approach to the Articulation
of Future Mine Countermeasure Concepts**

ABSTRACT

In 1996, a top-level concept of operations for mine countermeasures was first published. Since development of that concept of operations, considerable thought and study have been devoted to the long-term future of mine countermeasures. The emerging view is that of a war-fighting force employing both dedicated and organic mine countermeasures elements. This view dictates the need to reassess the mine countermeasures concept of operations and the associated architecture. What is now needed is a structure derived from the point of view that mine countermeasures is a core Navy function independent of whether that function is performed by dedicated or organic systems and platforms.

This paper presents an approach to developing such a structure. It is an appreciated fact that mine countermeasures is a complex warfare task that will play an increasingly important role in naval operations as the Navy continues to implement the littoral warfare strategy. In the past, mine countermeasures was regarded primarily as operations undertaken by specialized naval components independent of the main battle force components. In the future, implementation of the naval strategy will require an expanded view of mine countermeasures. The main battle force components will be required to possess organic capabilities to deal with the threat of mines through a cooperative engagement capability approach.

This paper focuses on articulating an overall framework that can be regarded as the point of departure toward defining and implementing a mine countermeasure capability fully compatible with, and integrated into, fleet operations.

INTRODUCTION

The origins of the modern sea mine can be traced back to the attempts in the 1700's by a number of innovative persons of different nationalities to attack warships with floating, explosive devices of a variety of designs. By World War I, the moored sea mine had developed into an effective weapon. World War II saw the development of influence mines, generally magnetic. In the years since, the mine has evolved into a sophisticated, multiple-sensor, stealth weapon capable of targeting both ships and submarines. Today, the inventory of mine types steadily increases as more complex and sophisticated mine designs are developed and offered for sale on the world's military arms market. At the same time, the older designs remain in the inventory of many countries, thus adding a unique dimension to the mine countermeasure problem -- namely, mine countermeasure techniques must have an exceptional degree of robustness across a wide variety of technologies and mine types. In addition to the wide variety of mine types, a number of delivery options are open to the mine-laying country. Mines designed for delivery by submarines, aircraft, and surface ships are all available.

When coupled with the difficulties posed by the littoral environment, there is little doubt that the mine threat is possibly the most difficult that the Navies of today face. It is also very clear that the mine problem is not going to disappear. In fact, it will get more difficult. Advanced shapes and case materials will make future mines more difficult to detect -- especially in the shallow water, littoral environments with the attendant significant amount of clutter. More and more countries will export mines of ever

20000425 083

1
DTIC QUALITY INSPECTED 3
AQ U00-07-1841

increasing technical sophistication. At the same time, neither exceptional infrastructure nor technical knowledge is required by an adversary to effectively operate and deploy these advanced mines. Couple all of this with the psychological impact of mines -- the fact that a country announces mines have been deployed can bring maritime operations, both military and commercial, to a stand still -- and it is abundantly clear that mines will remain the weapon of choice to oppose operations from the sea and to deny access to sovereign waters.

At the conclusion of the Persian Gulf war, there was a resurgence of interest in the subject of mine countermeasures. This resurgence resulted in a broad spectrum of initiatives focused on strengthening the Navy's mine countermeasures capabilities to meet the emerging needs of the forward-deployed forces operating primarily in the littoral regions of the world. However, the mine countermeasure concepts, operational approach, and force levels were a legacy of the Cold War. Mine countermeasures was considered to be a set of operations undertaken by specialized and dedicated naval components operating independently from the main battle force. The realization was not long in coming that mine countermeasures is a complex warfare area that will play an increasingly important role in future naval operations in the littorals. Implementation of the naval strategy requires an expansion of the concept of mine countermeasures to include not only the dedicated forces as we know them today, but some degree of organic capabilities resident within the main battle force components. It is the balance of this dedicated-to-organic capability that is the subject of debate today. The exact nature of this balance will be determined by a number of factors, not the least of which is the degree to which mine countermeasure operations are integrated into the combat system capabilities of surface platforms. In the face of this uncertainty, it is clear that a structured approach is an absolute necessity in order to address the technology insertion, operational

approach, and integration and validation questions that will drive the acquisition decision process.

A STRUCTURED APPROACH TO MINE COUNTER-MEASURES

Systems engineering is generally thought of as being applied to an individual weapon or combat system for the purpose of integrating the technical efforts of an entire design team in such a manner as to achieve an optimal design solution. However, the system engineering concept can be applied equally as well on a much broader basis to an entire discipline such as mine countermeasures. Indeed, with the advent of advanced communication and information capabilities, the regime of system engineering is rapidly expanding to take on a cooperative engagement context. This expansion of the systems engineering regime is being driven by the 'system of system' approach that has become widely recognized as descriptive of the future war fighting environment.

Mine countermeasures is ideally suited for the application of a true systems engineering approach. The benefits associated with such an approach are the same as for any systems engineering effort: more optimal approaches, coordinated efforts, cost and risk control, and a justifiable and defensible investment strategy. The overall challenge, however, is great since the mine countermeasures *system* is truly a *system of systems* -- the various components of which are very diverse. This diversity is a product of the complexity of the threat and the tremendous scope of the operating environments. This diversity will expand even further as mine countermeasures expands into the organic regime of surface warfare and begins to take on a cooperative engagement flavor.

The systems approach to the total mine countermeasures problem is an idea whose

time has come. For decades the Navy has approached the mine countermeasures problem in a piecemeal fashion. Breaking with this tradition is absolutely essential if the Navy is to bring mine countermeasures into the mainstream of war-fighting capabilities. Achievement of this type of goal requires a structured approach to the overall mine countermeasures problem.

Such a structured approach consists of six interdependent components:

- A Vision
- A Concept of Operations
- A Functional Architecture
- A Systems Allocation
- A Roadmap
- A Battle Laboratory

This overall structure and approach must at the same time be entirely consistent and compatible with the Naval Operational Concept and, in turn, with the Joint Vision 2010 as illustrated in Figure 1.

The attributes of each component are described in the following paragraphs. Each component is important to achieving the overall goal of integrating mine

countermeasures into naval war-fighting as a core competency. The process depicted in Figure 1 also has an overall theme: *Expanding mine countermeasures to a battle-force centric cooperative engagement capability.* The idea of making a “transition” to organic mine countermeasures has been much discussed in recent years. However, what is in reality needed, and what is described herein is not a “transition” - which implies there will be no further need for a dedicated force – but, more accurately, an *expansion* of mine countermeasures to be a naval core competency.

Vision

The vision is intended to provide a descriptive view of a future state toward which mine countermeasures desires to evolve. It can best be thought of as the “what” that mine countermeasures must become to best suit national needs. This future state must be responsive to both naval and joint operational needs, and, therefore, must be constructed to reflect the future role of mine countermeasures in supporting and enabling naval operations in the littoral environment.

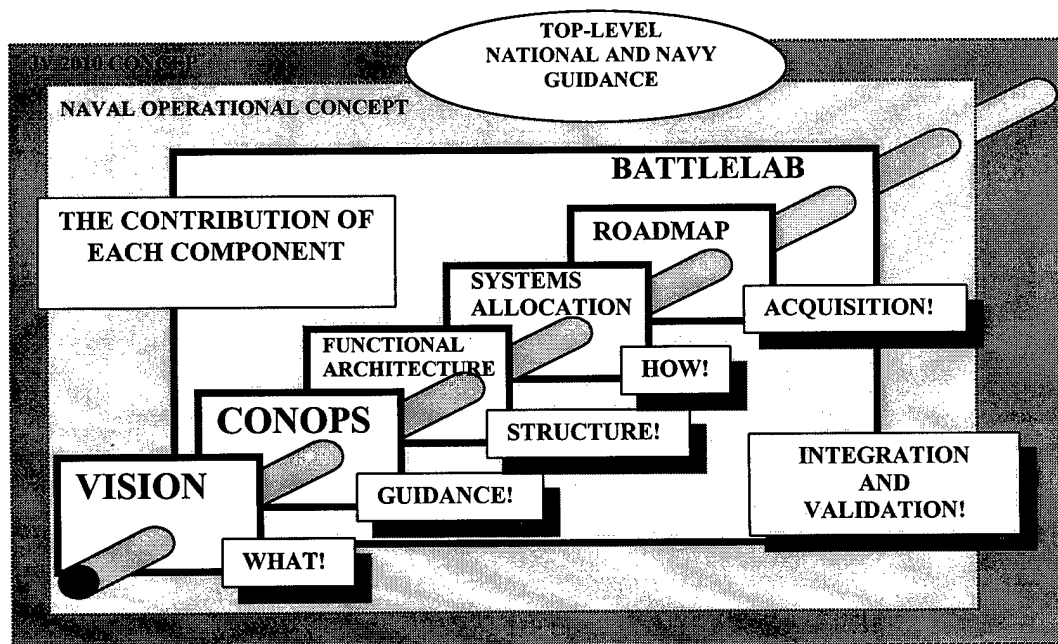

Figure 1. The Components of A Structured Approach to Mine Countermeasures

Some of the key attributes that must be incorporated into the future vision of mine countermeasures are described below.

First and foremost, the mine countermeasures vision must be clear and easy to understand. For too long, mine countermeasures has existed as an entity separate from the mainstream of naval warfare. This "separateness", coupled with the complexity of mine countermeasures, has led to a specialized structure, a functional architecture, and an operational nomenclature that is not in harmony with the integrated warfighting structure of surface warfare. Although the level of complexity will always exist due to the nature of the problem, a clear, integrated approach, compatible with the functional structure of surface warfare, is essential to ensure that the warfighter of the future understands the role of mine countermeasures, and correctly applies the techniques and technologies.

Mine Countermeasures must be viewed as one of the key enablers to support the major missions of Strike Warfare, Theater Air Dominance, and Expeditionary Warfare. Without a credible mine countermeasures capability, surface forces will be at a major operational disadvantage in the littoral environment when opposed by a determined adversary. Mine countermeasures is the key enabler if surface forces are to achieve unencumbered maneuver in the littoral warfare environment.

Mine countermeasures must take advantage of the increasing availability of autonomous systems. Combatants must be equipped with viable "fire and forget" mine countermeasures systems. This is necessary to ensure that the combatants can focus on their primary missions.

The key attribute that the future mine countermeasures capability must exhibit is that of a cooperative engagement capability (CEC) fully integrated with the surface warfare combatant operations. This implies that the mine countermeasure capabilities be

distributed throughout and integrated into the battle force. Today, we have the current triad of mine countermeasure ships, helicopter squadrons, and explosive ordnance disposal (EOD) detachments that operate almost totally independent of the battle force. Although these dedicated forces represent a mine countermeasure force cooperative engagement system by themselves, this capability is not integrated into the battle force. The expansion from a "mine countermeasures centric" to a "battle force centric" capability will of necessity dictate changes in both the manner in which mine countermeasure operations are conducted, and the types of equipment employed. In this future environment, mine countermeasures must make use of sensor and engagement systems that are distributed throughout the battle force, thus taking advantage of the network centric aspects of the future Navy. Such a distributed capability will require some unique systems to be located on combatants such as DDG-51 and DD-21, the large deck CVs, and the L-ships, and, quite possibly will require a future mine countermeasures platform capable of accompanying the battle force.

A vision based upon the above attributes will result in a mine countermeasures capability that fully enables the Navy to achieve its goal of unencumbered maneuver. Within this vision, however, it will be necessary to closely examine roles and responsibilities. For example, the surface combatant force may not be a suitable approach to perform the onerous and time-consuming task of administrative cleanup after a conflict. Such a task may best be accomplished by a force composed of dedicated mine countermeasure platforms.

Concept of Operations

For war-fighting purposes, the broad strategy outlined in the vision must be translated into the mine countermeasures skills and systems to be employed by the surface platforms. The development of

these skills and systems must be based upon a well-conceived, top-level Concept of Operations that can guide the subsequent development of doctrine, operational procedures, and tactics compatible with battle force operations. Such a concept of operations must be prudently broad in scope to ensure technical and operational capabilities across the spectrum of potential operations, from non-combat operations other than war to full-scale conflict.

Some of the key attributes that must be incorporated into the Concept of Operations of mine countermeasures are described below.

The Concept of Operations must revolve around the role of mine countermeasures as an enabler of littoral operations and must focus on the needs of the warfighter. This requires that the concept of operations be structured to encompass the complete range of potential mine countermeasures approaches and systems, yet be simple and clear. The Concept of Operations must span the range from ship self-protection, to battle space preparation, to determination of the presence or non-presence of mines, and, finally, to the ultimate clearance of mines within the lanes of transit and the areas of operations.

Achievement of a vision of the type articulated requires that mine countermeasures awareness be elevated to the level of the battle force commander just as for other major warfare areas. Within this context, the battle force commander – together with his staff -- becomes the one who articulates the mine countermeasure requirements in consonance with the force mission assignment. A generalized operational process is depicted in Figure 2. In its broadest interpretation, this process begins with the definition of the deployment requirements by the battle force commander. These requirements will be described in terms of battle force operational area needs and transit routes into the operating area. The result is an

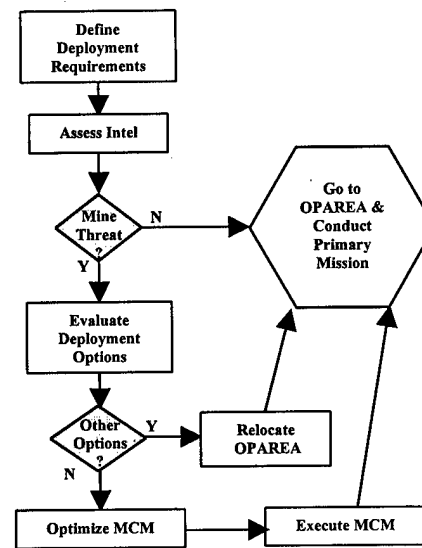

Figure 2: Notional Operational Process

articulation of needs in terms of operating areas and lanes of transit. This is followed by an assessment of the intelligence information to determine the types of threats likely to be encountered to include not only missiles and opposing Navy platforms, but also mines. This assessment addresses not only the potential mine-laying capabilities of the adversary, but also an assessment of the mineable environment. Based upon the totality of the information at hand the battle force commander then evaluates action options ranging from avoidance of the mined areas to the employment of a full range of clearance operations. The driving factors are always time and risk.

The Concept of Operations must lead to a few meaningful and readily understandable 'Figures of Merit'. The set of FOM's should be amenable to expressing the quality of the mine countermeasures operations in terms of the time and risk associated with the clearance of 'lanes of transit' and 'areas of operations', both of which have meaning to the battle force commander.

Functional Architecture

Once the mine countermeasures Vision and Concept of Operations have been articulated, these must be further translated into a coherent structure that depicts the functional relationships of the various components of the mine countermeasures system. Such a "structure" is best described as a top-level functional architecture. As mine countermeasures expands into the organic realm and employs a cooperative engagement operational philosophy, the functional architecture will become increasingly important and essential for the purpose of communicating a clear understanding of how all of the 'systems' fit together in an integrated manner to achieve a total mine countermeasures capability.

Some of the key attributes of such a functional architecture for mine countermeasures are described below.

First of all, the architecture must be compatible with Navy war-fighting. It must be expressed in terms that are understood by the Navy as a whole - not just the mine countermeasures community. A possible structure that meets this requirement is based upon the plan-sense-control-engage paradigm illustrated in Figure 3. The sense function applies to the detection and acquisition of contacts and targets. The engage function applies to activities that involve direct action directed at a mine or mine-like target. The control functions may well have a broad two-fold meaning of platform-signature control and maneuver

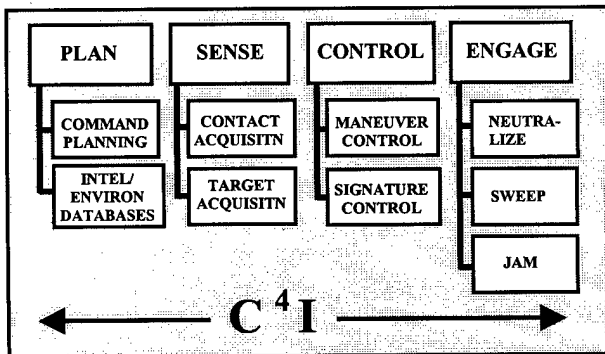

Figure 3. A Notional Architecture

control associated with the engagement function. Signature control functions are concerned with the mine's acquisition of a ship or with a sensor's acquisition of a mine. The maneuver control functions relate to a platform and weapon performance while executing the sense and engage actions.

In the future network-centric battle force, the organic mine countermeasure functions will of necessity be distributed across the platforms that make up the surface action group. One example of such an operational functional architecture is what is known as an "H-Architecture" of the type illustrated in Figure 4. This H-architecture is ideal for

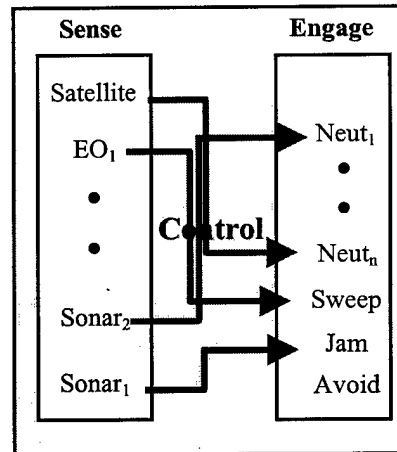

Figure 4. Generic H-Architecture Concept

implementing the concept. It takes advantage of the sense function (which includes satellites and electro-optics, as well as sonars) and the engage function (including neutralization, sweep, and jam systems) being distributed by allowing them to be linked up through a common control function, which itself is distributed in a network-centric battle force.

The mine countermeasures operational components must be capable of effectively integrating with all elements of the command and operational elements of the battle force C⁴I interfaces. The C⁴I capability thus becomes an underlying capability that permeates all of the operational phases of mine countermeasures.

Indeed, without the presence and availability of the fleet C⁴I capability, the cooperative engagement approach to mine countermeasures will not be possible.

System Allocation

One of the primary benefits of a viable architecture is that it provides the necessary structure to show which systems and equipment contribute to the accomplishment of the various functions. The functions are the foundational structure within which existing systems, developmental capabilities, and technologies can be mapped (or allocated) to form a complete, hierarchical picture of the total mine countermeasures systems approach. Such a functional architecture will clearly show where each of the various system components contributes to the overall mine countermeasures capabilities.

Some of the key attributes of a systems allocation for mine countermeasures are described below.

All of the systems in the H-architecture are distributed across the functions. This complete list of systems then becomes the "superset" describing the components of the total mine countermeasures system. It is important to realize that in the future the individual components of the superset will be distributed throughout the battle force. It is entirely possible that no single platform will possess an entire, stand-alone mine countermeasures capability. The distributed nature of this future capability is the essence of the concept of the battle-force cooperative engagement capability for mine countermeasures. The exception, of course, would be a new, dedicated mine countermeasures platform capable of operating in a battle-force environment.

The mine countermeasures 'system-of-systems' will employ a variety of technically advanced autonomous vehicles to perform the sense and engage functions. These

autonomous vehicles will greatly enhance the ability of the battle force to effectively implement mine countermeasures actions while at the same time allowing surface combatants to prosecute their principal war-fighting missions. The family of autonomous vehicles contributing to future mine countermeasures actions will include unmanned aerial vehicles (UAVs), unmanned underwater vehicles (UUVs), unmanned surface and semi-submersible vehicles, and unmanned ground vehicles (UGVs) -- all of which will be necessary to address the range of mine countermeasure missions and environments. The systems allocation will show where each autonomous system contributes to the overall mine countermeasures mission.

Control of the autonomous systems is vital. A single control system is ideal. One that is currently under investigation is the Tactical Control System (TCS). The TCS is being designed as a single control system capable of interfacing with all types of autonomous vehicles. This system itself can then be distributed through the battle force, such that individual platforms can readily pass control of the system(s) to other platforms - thus optimizing the war-fighting functions of the battle force as a whole.

A further technology enabler that will be evident in the systems allocation will be that of a distributed sensor network capable of monitoring wide operational areas. The ability of such a distributed sensor network to monitor mine-laying activity will have functional application during all phases of a mine countermeasures operation -- before, during and after a conflict. The nodes of such a distributed sensor system become an integral part of the overall battle force communications network. Such a capability will be complementary with autonomous systems for the purpose transferring a wide variety of tactically valuable information back to the battle force.

Roadmap

Implementation of the next generation of mine countermeasures requires that a roadmap be developed to guide the "acquisition" of the system components. The roadmap thus becomes the plan for acquiring the systems capabilities that will enable the Navy to realize the vision of a mine countermeasures capability that is integrated into the warfighting structure of the battle force. The Roadmap should have one central theme -- expanding mine countermeasures to a battle force centric capability.

Some of the key attributes of a roadmap for mine countermeasures are described below.

First and foremost, the roadmap must be based on a fundamental Navy resolve to achieve a position and structure where mine countermeasures is integrated into Fleet operations as a core capability. Without this resolve the expansion of mine countermeasures to be a core warfighting competency will not succeed. The surface warfare community through the early investment and demonstration of the Remote Minehunting System has demonstrated this resolve.

In the current austere budget environment, it is absolutely essential that the roadmap be realistically phased to the budget and acquisition process. One possible approach would be to have a phased POM where each cycle places primary emphasis on a single aspect of the functional architecture. For example, the first POM cycle could focus on ensuring that the fundamental aspects of the 'sense' function of the architecture is addressed from a battle force perspective. The following POM could then focus on the 'engage' function, and so forth. This approach would have to be tempered by the reality that the functions cannot be totally divorced from each other. In addition, such an approach would require a dedication to a long-term, stable program.

The roadmap must clearly illustrate how the Navy will expand from the mine-countermeasures centric approach to the battle-force centric approach. This expansion has implications not only in systems application but also in areas such as surface warfare training, force workup procedures, and operational tactics. The roadmap must thus address each of the functional areas of the architecture and clearly show the evolution of existing systems, or the introduction of new systems as the case may be, to ensure that the battle force possesses a viable mine countermeasures capability. As the Navy makes this expansion, it is anticipated that autonomous systems and a cooperative engagement approach will both play increasingly important roles.

It is absolutely essential that the roadmap be sensitive to the insertion of new technology. New technologies will be a major contributor to the success of the philosophy of expanding mine countermeasures to be a capability fully integrated into battle force operations. The technology insertions are expected to have a significant impact in the areas of sensor networks and the timely engagement of mine threats.

Finally, it is essential that the mine countermeasure system components be compatible with the other major systems employed by the surface warfare platforms.

Battlelab

The concept of a mine countermeasures Battlelab is illustrated in Figure 5. The battlelab is an essential element for achieving the expansion of mine countermeasures to a capability that is fully integrated into fleet operations. The battlelab represents the mechanism whereby this expansion can be made achievable and the desired systems engineering approach to mine countermeasures can be fully recognized. Furthermore, it is the tool for examining alternative mine countermeasures

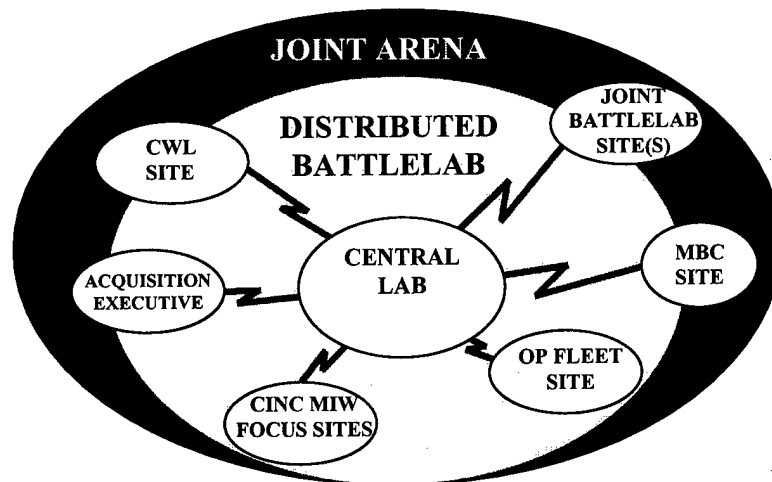

Figure 5. Mine Countermeasures Battlelab Concept

strategies and concepts of operations, and for integrating these into fleet operations. The battlelab will become the central tool for supporting acquisition decisions, evaluating new technologies, and developing the new tactics associated with battle-force level mine countermeasures operations. In the cooperative engagement approach, it is essential that both the system developers and the end users have access to up-to-date threat, tactical, and operational data. The battlelab will be the central repository of these databases. Tailored cells of the battlelab, located with the end user, will provide the capability to conduct mission rehearsals and post-mission reconstruction's.

Some of the key attributes of a battlelab for mine countermeasures are described below.

The mine countermeasures battlelab will be a system that makes full use of the current distributed modeling, simulation, analysis and databasing technologies. Built around a core central facility, the battle lab will consist of a series of distributed 'cells'. Each cell will be located at the site of the major end-users, R&D activities, doctrine developers, training providers, and acquisition providers.

A key attribute of the end-user cell will be the ability of that particular cell to focus on

the mine countermeasure requirements that are unique to the users specific Area of Responsibility (AOR) requirements. This will be particularly valuable to specific CINCS. The CENTCOM cell for example, would be tailored to focus on the specific AOR requirements that are unique to the mid-east operational area. In a like manner, a cell located at the Naval Warfighting Development Command would focus on the role of mine countermeasures in the area of doctrine development, and so forth.

The central laboratory site will serve as the principal repository of mine countermeasure databases, models and simulations, algorithms, and technical expertise necessary to support such a distributed capability. The battlelab thus becomes the effective mechanism for sharing mine countermeasures information and data bases among the diverse user community.

The battlelab is essential to the entire process defined at the beginning of this paper. It is the integration and validation tool that links the entire process. As such it is the methodology that supports tactics validation, technology insertion, systems tradeoffs, and operational usage assessments.

This distributed Battlelab concept is fundamental to achieving the integration of

mine countermeasures into naval warfare and joint warfighting. This integration is in turn essential for the expansion of mine countermeasures.

CONCLUSION

Implementation of the current naval strategy will require a mine countermeasures capability that is integrated into fleet operations. This integrated capability will require expanding the current approach to mine countermeasures into a cooperative engagement approach.

This paper describes a structured process that can be used as the basis for the development of the future mine countermeasures concept. Each component of the process has been described in terms of a set of fundamental attributes.

Daniel E. Harris is an employee of the Naval Surface Warfare Center, Coastal Systems Station, in Panama City Florida. He earned a B.S. degree in Mechanical Engineering from the University of Maryland in 1984. He began his Government service in 1984 at the Naval Surface Warfare Center in White Oak, Maryland, he worked on the MK50 torpedo warhead program as a design engineer. He transferred to the Mine Division in 1994 where he managed several shallow water Mine Countermeasures (MCM) projects. Before relocating to NSWC's Coastal Systems Station (CSS) facility in 1995, he served in the Office of the Chief of Naval Operation's Mine Warfare Branch (CNO-N852). While at CSS, he led an effort to apply systems engineering discipline to the warfare area of mine warfare. He is currently detailed to OPNAV N852 once again, where he serves as the Mine Warfare C4I requirements officer.

Donald W. Shepherd is an employee of the Naval Surface Warfare Center, Coastal Systems Station, in Panama City Florida. He holds a Bachelor of Science degree in Physics from Mississippi State University and a Master of Engineering from the University of Florida. Over a career that has spanned more than thirty-five years, Mr. Shepherd has worked as a researcher and engineer in the areas of surface and submarine torpedo countermeasures, acoustic warfare, mine warfare, and naval special warfare. From 1982 to 1983 he served as the senior Science Advisor to Commander, Naval Surface Forces U. S. Atlantic Fleet, Norfolk, Virginia. During the period 1986 - 1988 he was a principal technical advisor to the head of the Naval Special Warfare Division of the Chief of Naval Operations. From 1989 - 1991, Mr. Shepherd was the U.S. lead scientist for the Joint Feasibility Study portion of the Joint US/UK Surface Ship Torpedo Defense Program. During the period 1994 - 1997, Mr. Shepherd served as the senior warfare systems advisor to the Mine Warfare Division of the Chief of Naval Operations. Mr. Shepherd has published numerous technical reports and journal articles. He is also a published author in the commercial sector.