

**NAVAL POSTGRADUATE SCHOOL
Monterey, California**



20000501 118

THESIS

**ANALYSIS AND EVALUATION OF
CURRENT CHALLENGES IN THE
AEROMEDICAL EVACUATION MISSION SEGMENT
OF THE CIVIL RESERVE AIR FLEET**

by

Dawn D. Richardson

March 2000

Thesis Advisor:
Associate Advisor:

Ira Lewis
Lee Edwards

Approved for public release; distribution is unlimited.

DTIC QUALITY INSPECTED 3

REPORT DOCUMENTATION PAGE

Form Approved
OMB No. 0704-0188

Public reporting burden for this collection of information is estimated to average 1 hour per response, including the time for reviewing instruction, searching existing data sources, gathering and maintaining the data needed, and completing and reviewing the collection of information. Send comments regarding this burden estimate or any other aspect of this collection of information, including suggestions for reducing this burden, to Washington headquarters Services, Directorate for Information Operations and Reports, 1215 Jefferson Davis Highway, Suite 1204, Arlington, VA 22202-4302, and to the Office of Management and Budget, Paperwork Reduction Project (0704-0188) Washington DC 20503.

1. AGENCY USE ONLY (Leave blank)		2. REPORT DATE March 2000	3. REPORT TYPE AND DATES COVERED Master's Thesis	
4. TITLE AND SUBTITLE : ANALYSIS AND EVALUATION OF CURRENT CHALLENGES IN THE AEROMEDICAL EVACUATION MISSION SEGMENT OF THE CIVIL RESERVE AIR FLEET			5. FUNDING NUMBERS	
6. AUTHOR(S) Richardson, Dawn D.			8. PERFORMING ORGANIZATION REPORT NUMBER	
7. PERFORMING ORGANIZATION NAME(S) AND ADDRESS(ES) Naval Postgraduate School Monterey, CA 93943-5000			10. SPONSORING / MONITORING AGENCY REPORT NUMBER	
9. SPONSORING / MONITORING AGENCY NAME(S) AND ADDRESS(ES) N/A			10. SPONSORING / MONITORING AGENCY REPORT NUMBER	
11. SUPPLEMENTARY NOTES The views expressed in this thesis are those of the author and do not reflect the official policy or position of the Department of Defense or the U.S. Government.				
12a. DISTRIBUTION / AVAILABILITY STATEMENT Approved for public release; distribution is unlimited.			12b. DISTRIBUTION CODE	
13. ABSTRACT (maximum 200 words) The Civil Reserve Air Fleet (CRAF) is a contractual arrangement between Air Mobility Command (AMC) and U.S. air carriers. The agreement states that the airlines will commit a specified number of planes to AMC in return for a portion of peacetime government business. The Aeromedical Evacuation (AE) segment of CRAF is the only segment that requires modification to committed aircraft and, therefore, more risk to the airlines. Up until fiscal year 2000, AMC had never filled its requirements for AE. AMC would like to have more airlines join the AE segment, with each airline providing a few aircraft. This thesis considers the history of the program, lessons learned from previous operations, current strategies, and some alternatives to investigate in order to improve the CRAF AE program and participation by the airlines.				
14. SUBJECT TERMS Civil Reserve Air Fleet, Aeromedical Evacuation, Aeromedical Evacuation Ship Set, Liquid Oxygen Support System, Department of Transportation Office of Emergency Transportation			15. NUMBER OF PAGES 65	
17. SECURITY CLASSIFICATION OF REPORT Unclassified			16. PRICE CODE	
18. SECURITY CLASSIFICATION OF THIS PAGE Unclassified		19. SECURITY CLASSIFICATION OF ABSTRACT Unclassified		20. LIMITATION OF ABSTRACT UL

NSN 7540-01-280-5500

Standard Form 298 (Rev. 2-89)
Prescribed by ANSI Std. Z39-18

THIS PAGE INTENTIONALLY LEFT BLANK

Approved for public release; distribution is unlimited.

**ANALYSIS AND EVALUATION OF CURRENT CHALLENGES IN THE
AEROMEDICAL EVACUATION MISSION SEGMENT OF THE
CIVIL RESERVE AIR FLEET**

Dawn D. Richardson
Lieutenant Commander, United States Navy
B.S., Purdue University, 1983

Submitted in partial fulfillment of the
requirements for the degree of

MASTER OF SCIENCE IN MANAGEMENT

from the

**NAVAL POSTGRADUATE SCHOOL
March 2000**

Author:



Dawn D. Richardson

Approved by:



Ira A. Lewis, Thesis Advisor

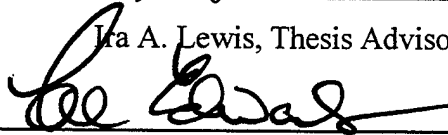

Lee Edwards, Associate Advisor

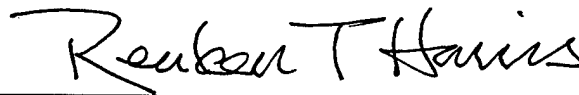

Reuben T. Harris, Chairman
Department of Systems Management

THIS PAGE INTENTIONALLY LEFT BLANK

ABSTRACT

The Civil Reserve Air Fleet (CRAF) is a contractual arrangement between Air Mobility Command (AMC) and U.S. air carriers. The agreement states that the airlines will commit a specified number of planes to AMC in return for a portion of peacetime government business. The Aeromedical Evacuation (AE) segment of CRAF is the only segment that requires modification to committed aircraft and, therefore, more risk to the airlines. Up until fiscal year 2000, AMC had never filled its requirements for AE.

AMC would like to have more airlines join the AE segment, with each airline providing a few aircraft. This thesis considers the history of the program, lessons learned from previous operations, current strategies, and some alternatives to investigate in order to improve the CRAF AE program and participation by the airlines.

REFERENCES	43
INITIAL DISTRIBUTION LIST	49

LIST OF FIGURES

1. B-767-300 AESS Drawing for 87 Litter Installation.....	21
2. Paired Double Stanchion Assembly for Litters Portion of AESS.....	22
3. Nurse Station Assembly Portion of AESS.....	23
4. Photograph of Casualty Transfer System (CTS) Next to B-767.....	34
5. Patient Loading System (PLS).....	34

THIS PAGE INTENTIONALLY LEFT BLANK

LIST OF ACRONYMS AND/OR ABBREVIATIONS

AE	Aeromedical Evacuation
AECM	Aeromedical Evacuation Crew Member
AESS	Aeromedical Evacuation Ship Set
AFB	Air Force Base
AHOS	Advanced Hybrid Oxygen System
AMC	Air Mobility Command
ARB	Air Reserve Base
ASD (MI&L)	Assistant Secretary of Defense (Manpower, Installations and Logistics)
ASTS	Aeromedical Staging Squadron
ATA	Air Transport Association
ATC	Air Transport Command (now AMC)
B-	Boeing
BS	Block Speed
CAMI	Civilian Access to Military Installations
Capt.	Captain
Cdr.	Commander
CEP	CRAF Enhancement Program
CINC	Commander-in-Chief
CINCMAC	Commander-in-Chief, Military Airlift Command
CLS	Contract Logistics Support
Col.	Colonel
CONUS	Continental United States
CORE	Contingency Response Program
CRAF	Civil Reserve Air Fleet
CTS	Casualty Transfer System
DESC	Defense Energy Support Center
DFSC	Defense Fuel Supply Center (now DESC)
DLA	Defense Logistics Agency
DOC	Department of Commerce
DoD	Department of Defense
DODD	Department of Defense Directive
DOT	Department of Transportation
ECP	Engineering Change Proposal
ER	Extended Range
ETOPS	Extended Twin Engine Operations
FAA	Federal Aviation Administration
FDA	Food and Drug Administration
GAO	General Accounting Office
GATM	Global Air Traffic Management
GCSM	Great Circle Statute Miles
GHQ	General Headquarters
GSA	General Services Administration
Hz	Hertz

ICMOP	In-CONUS Movement of Patients
LCA	Liquid Oxygen Container Assembly
LOSS	Liquid Oxygen Support System
Lcdr.	Lieutenant Commander
LGen	Lieutenant General
Lt.	Lieutenant
LtCol.	Lieutenant Colonel
MAC	Military Airlift Command (now AMC)
Maj.	Major
MATS	Military Air Transport Service (now AMC)
MOU	Memorandum of Understanding
MTMC	Military Traffic Management Command
MPM/D	Million Passenger Miles per Day
MTM/D	Million Ton Miles per Day
MVP	Mobilization Value Points
NACA	National Air Carriers Association
NATO	North Atlantic Treaty Organization
NAVTRANS	Navy Transportation Support Center
ODS	Operation Desert Storm
OET	Office of Emergency Transportation (DOT)
Pan Am	Pan American Airlines
Phoncon	Telephone Conversation
PL	Payload
PLS	Patient Loading System
P/N	Part Number
PUR	Productive Utilization Rate
RSC	Raytheon Systems Corporation
SEA	Southeast Asia
SRE	Short Range Equivalent
STC	Supplemental Type Certificate
TACC	Tanker Airlift Control Center
TWA	Trans World Airlines
UA	United Airlines
U.S.	United States
USAF	United States Air Force
USD (A)	Under Secretary of Defense (Acquisition) (now USD (AT&L))
USD (AT&L)	Under Secretary of Defense (Acquisition, Technology and Logistics)
USTC	United States Transportation Command
USTRANSCOM	United States Transportation Command
VAC	Volts of Alternating Current
WBE	Wide Body Equivalent
WW I	World War I
WW II	World War II

ACKNOWLEDGMENT

I would like to first express my gratitude to Dr. Ira Lewis and Dr. Lee Edwards. Their knowledge, encouragement, patience and guidance made this thesis possible.

I owe CAPT Mark Brown and his staff at NAVTRANS a debt of gratitude for recognizing the importance of thesis travel and funding my research trip. This thesis would have been extremely difficult to complete without the contacts and information I garnered on that trip.

Mr. Michael Spehar and CDR Billy Combs from USTRANSCOM were invaluable in my research. Thanks for your time and for keeping me current on the issues.

I'd like to thank everyone at AMC in both the DOF and SGX offices for their cooperation and assistance.

I am also grateful to the airline representatives for their frank conversations and willingness to discuss issues from their perspective.

I appreciate the insight provided by Mr. Ron Priddy from both a historical perspective and current airline industry official capacity. His experience has given him a unique viewpoint.

I owe a great deal to the Systems Management Curricular Office staff for taking care of me and to the Coffee Cart people for keeping me conscious.

I'd like to thank CAPT Kevin Carman for being my mentor and always having confidence in, or rather taking for granted, my abilities to tackle the toughest projects.

I now understand and appreciate my family for having the highest expectations of me. Without this, I would probably not have been as successful in my endeavors.

I owe my sanity to LCDR Jo Lewis and her family, MAJ Kim Daub and her family, and LT Marie Bambao. Thanks for encouraging, supporting and listening to me.

THIS PAGE INTENTIONALLY LEFT BLANK

I. INTRODUCTION

A. PURPOSE

This thesis will explore some of the key challenges facing the Department of Defense (DoD) in attaining and maintaining commitment to the Aeromedical Evacuation (AE) segment of the Civil Reserve Air Fleet (CRAF). If activated, this segment of CRAF would prove critical to the health, welfare and morale of service members injured in the line of duty. The research will consider the history of the program, lessons learned from previous operations, current aeromedical evacuation strategy, capabilities provided by the airlines and the technology currently in place. The goal of this research is to determine areas to be considered to improve the design of and participation in the program.

B. SCOPE AND METHODOLOGY

This thesis will explore potential areas that U.S. Transportation Command (USTRANSCOM) could consider altering in order to improve participation in the AE segment of CRAF. It is the intent of this thesis to encourage discussion in areas that have been closed or never initiated in this vital program. The information for this thesis was gathered by personal interviews and literature review.

C. ORGANIZATION OF STUDY

Chapter II will:

detail the evolution of AE and CRAF,

examine AE requirements and

lessons learned from recent operations, and

compare AE to the CRAF Enhancement Program (CEP).

Chapter III will:

discuss current challenges, including Supplemental Type Certificates (STC), Corrosion, Liquid Oxygen Support Systems (LOSS) and Aeromedical Evacuation Ship Sets (AESS). The chapter also will examine

current industry capabilities and

technological requirements. Finally, Chapter III will

provide an industry perspective on some of the issues.

Chapter IV will then:

present findings and offer recommendations for attaining and maintaining participation in the AE segment of CRAF. Chapter IV also will

suggest topics for further research.

D. RESEARCH APPLICATION

USTRANSCOM and AMC in particular are the intended primary beneficiaries of this study. AMC strategic planners may be able to apply the recommendations from this thesis in order to improve the CRAF program. It is hoped that the AE segment of CRAF will never have to be activated, but if it must, then we should have the best program possible.

II. BACKGROUND

A. EVOLUTION OF AEROMEDICAL EVACUATION AND CRAF

Aeromedical Evacuation began as early as 1870, when soldiers who had been wounded in the siege of Paris were airlifted out by balloon (Thomas, 1985, p. 8). In 1912, Capt. George Gosman and Lt. Albert Rhoades went to Washington, DC to recommend that the airplane be used to evacuate wounded soldiers from the battlefield to hospital facilities. The War Department rejected the idea, but Gosman and Rhoades proceeded to build the first air ambulance with their own funds. Although the aircraft crashed on its maiden flight, the potential of the airplane in transporting patients was recognized. (Davis, 1986, p. 19)

The Civil Reserve Air Fleet (CRAF) is a program with a history reaching back to the beginnings of aviation. The United States entered World War I late in the war, in 1917. At that time, the U. S. ordered 12,000 aircraft; however, the fledgling U.S. aircraft industry delivered only 15 aircraft in the first year. The industry was trying to build copies of French designs, but they were obsolete as soon as they were built. The French industry was leading in innovation due to its early active participation in the war. (Priddy, 1993, p.1)

Thousands of new pilots were needed for World War I. The lack of well designed aircraft combined with the effort to train pilots quickly resulted in frequent crashes. In 1918, Capt. William Ocker and Maj. Nelson Driver converted a JN-4 Jenny biplane into

an air evacuation vehicle by removing the rear cockpit and fitting an Army stretcher into the space. The use of air evacuation remained minimal in World War I. (Davis, 1986, p. 20)

Prior to 1920, planes were controlled by individual units with no coordination. Then, in 1920, the Army Air Service was formed. During the 1920s and 30s, five tenets composing the doctrine of military air transportation emerged:

1. The primary and overriding role of military air transportation is to support the air forces. As such, it belongs to the air forces and will be controlled by them.
2. Military air transportation is vital to the flexibility and mobility of GHQ (Headquarters) air forces. Some degree of air transportation would be organic to that force, and other air transportation assets will be called upon to augment that fighting force when required at the expense of other missions.
3. Military air transportation is also important as a logistics tool for the entire air force. It offers an economic and very reliable way to distribute supplies and to avoid certain stock level costs.
4. All of the advantages of military air transportation notwithstanding, it is less important than the development, acquisition, and operation of combat forces. As the infantry is called the queen of battle, so too combat aviation may be called the queen of the air forces.
5. Civil air transportation is relatively plentiful and becoming more so with time. Although civil air transportation airplanes are not perfectly designed for military purposes, they are sufficiently so that the air forces will rely on mobilizing them in wartime, at the expense of building an organic capability in peacetime. (Miller, 1988, p. 19)

In 1934, the Baker Board, a study group appointed by the Secretary of War, stated that commercial planes were the transportation reserve for national defense (Priddy, 1993,

p. 4). This is the first such recommendation on record and the beginnings of what was to become CRAF.

In the initial stages of WW II, the U.S. was 85% dependent upon commercial carriers for airlift. Before the United States entered the War, Britain requested assistance ferrying aircraft from plants in the U.S. to the east coast of the U.S. In 1941-42, this developed into a Pan American Airways contract for ferrying and air transport operation along South Atlantic routes from the United States to Khartoum. Pan Am delivered 464 planes and was responsible for recruiting crews and maintenance personnel, establishing training programs, setting up bases, and administering the entire system. (Miller, 1988, p. 28)

Nonetheless, at the beginning of the war, the War Department had scarcely any long-range transports available: 4 Boeing Clippers, 5 Stratoliners (on contract), and 11 converted B-24s. The commercial airlines had 406 multiengine transports, but all except a handful were twin engine. However, because of their reservoir of trained personnel and facilities and their invaluable operating experience, "it was immediately obvious that the emergency war needs for air transportation could not be met without recourse to the services of the civil airlines." When President Roosevelt signed the executive order on 13 December (1941) directing the secretary of war to take possession of any portion of any civil aviation system required in the war effort, a plan in existence since 1936 allowed for the immediate harnessing of those assets. Contracts were quickly let with Pan American Airways, Transcontinental, and Western Air, Inc., providing for aircraft ferrying and air transport services over numerous worldwide routes. Eventually every major civil air carrier provided some type of contract service. (Miller, 1988, p. 31, quoting Administrative History, Ferrying Command, 29 May 1941-30 June 1942, p. 64)

The Pan American operation contracted by the British previously was militarized in 1942 as a result of the executive order.

In 1941, David Grant, the first U.S. flight surgeon, proposed establishing an air evacuation service, but it was rejected by the highest echelons of the Army. Air evacuation services were approved by the War Department on June 18, 1942 as a result of entering World War II. C-46, C-47 and C-54 transport aircraft were equipped with litters and carry-on medical equipment. Cargo would be transported to the front and patients would make the return trip. In 1943, 173,000 patients were returned to the U.S. with an on-board death rate of 6 per 100,000. In 1945, 545,000 patients were returned with a death rate of 1.5 per 100,000. Between September 1942 and November 1945, 1,338,717 patients were transported by air. Air evacuation was not standardized in any theater during World War II. (Davis, 1986, p. 20) Accordingly, the War Department established the Army's Air Transport Command (ATC). In 1945, the policy of the ATC was as follows:

ATC should be the preeminent airline operator in the world, better than any airline organization; but it should maintain very close coordination with the U.S. airlines, with ATC as the point of contact with civil aviation.

ATC should plan to move 36,000 troops and equipment promptly, with civil airlines contributing 3/4 of the airlift capability....

ATC was not only a military instrument; it was also an instrument of national economic policy....Foreign concerns that the U.S. government would use ATC as a wedge to assist in the development of international U.S. carriers were well founded. The president, the War Department, and the Department of State were all concerned that the tremendous strides made and advantages gained by ATC in the war, both technical capabilities and of the magnificent international route structure (with all its attendant facilities), would be lost to foreign governments and carriers. Luckily, ATC could reduce its wartime level of effort, thus also reducing its visibility in the marketplace, and still contribute to the enhancement of American civil air carriers, because the carriers could fill in with their newfound capability. This not only allowed a mobilization base for the

next war, it was very cheap airlift at a politically and militarily acceptable rate. Doctrinally, this meant that a significant amount of air transport power would reside in the civilian sector, theoretically available when needed. It also meant a continuation of the 20-year trend of relying on airplanes designed for civil airlines rather than military purposes. (Miller, 1988, p. 73)

The strategic airlift heritage derived from WW II follows:

Strategic airlift will exist in peacetime at a militarily acceptable minimum strength to be prepared for extensive expansion during wartime. Strategic airlift will rely overwhelmingly on civil aviation for its initial wartime capabilities. In peacetime, the Air Force will encourage, to the maximum extent possible, the development and success of national and international U.S. civil aviation. (Miller, 1988, p. 73)

This was first evidenced by the response to the Berlin Crisis in 1948, when 110 civilian aircraft from 25 companies were contracted to provide airlift (Abscher, 1988, p. 18).

The National Security Act of 1947 led to the creation of the Department of Defense (DoD) and the transfer of most of the Army's airlift responsibilities to the newly created U.S. Air Force (USAF). MATS (Military Air Transport Service), which was created in June 1948 within the USAF, consolidated the airlift missions of the armed forces, incorporating ATC also. However, routes of interest to only the Navy were left to the Navy. (Miller, 1988, p. 174) The mission statement directed that MATS be responsible for aeromedical airlift for all the military services outside the battle zone. In 1949, the Secretary of Defense designated air as the primary method of transporting patients. (Davis, 1986, p. 21)

At the outbreak of the Korean War, MATS contracted 66 aircraft to provide airlift support from the United States to Japan in support of U.S. forces and later added 100 more aircraft. In 1951, President Truman's Executive Order 10219 directed the

Department of Commerce to formulate plans to use civil aviation to help meet emergency needs. A Memorandum of Understanding (MOU) was drafted between the Department of Defense (DoD) and the Department of Commerce implementing the order. A plan was established in 1952, which finally gave the civilian air carriers' relationship with the military a name: CRAF. (Burshnick and Fletcher, 1976, p. 26) During the Korean War, civilian airlines (60- four-engine transports) carried 67% of the passengers, 56% of the cargo, and 70% of the mail to Japan for further transport to the front in Korea. Strategic airlift lessons learned from the Korean War included: do not count on a rapid response from MATS without giving it a peacetime base from which to respond; and count on civil airlines to be responsive for routine, large lifts into noncombat zones. (Miller, 1988, pp. 203-204)

Meanwhile, the Air Transport Association (ATA) was promoting maximum utilization of civilian aircraft to both Congress and DoD. ATA's members (the major U.S. carriers) enjoyed the wartime business and recognized the future profit potential of DoD airlift services. MATS was pushing for more aircraft of its own and wanted to expand its capabilities, but Congress favored ATA. In 1952, MATS updated its 1948 mission statement stating that all of DoD would coordinate with MATS before negotiating or finalizing contracts with civilian carriers. Additionally, MATS would continue planning for the maximum utilization possible of civil carriers and was authorized direct contact with the civil and government entities required. (Miller, 1988, p. 205)

In 1953, the MATS mission was restated to include air evacuation as a major function rather than a by-product of cargo lift. In 1954, the vehicle to accomplish this mission, the C-131A Samaritan (a military version of the Convair Metropolitan), was added to the fleet. The C-131A Samaritan was the first fully pressurized, twin-engine transport in the USAF and could accommodate 40 ambulatory or 27 stretcher patients or a mix of both. (Davis, 1986, p. 21) The C-130 Hercules entered the fleet in 1956 and remains active in service. It was a tactical aircraft designed mainly for airdropping troops and equipment into hostile areas, but was also versatile in its capabilities. The C-130 can hold 74 litters with two medical attendants. (USAF Fact Sheet, C-130 Hercules)

In 1957, the Senate Committee on Appropriations explained the need for DoD to use commercial carriers:

In summary we do not feel that sufficient effort has been made by the DoD in the international and overseas field to adjust its use of air transportation so as to use existing unutilized capacity of the US air carriers....funds so reprogrammed (from the purchase of additional aircraft) to be applied toward procuring the services of US civil air carriers to meet as nearly as possible 40% of the passenger requirements and 20% of the cargo requirements of the MATS. (Miller, 1988, p. 239)

The 1958 Holifield Subcommittee decreed that ATA's members would carry everything with the exception of oversize or exceptionally heavy items, items with unusual security precautions, or items with a close relationship with tactical combat units. DoD argued that MATS wartime training provided a by-product of airlift capability that should be used to the maximum extent possible. The final outcome of all of this jockeying for business was that MATS would modernize and ATA would improve CRAF cargo capability. (Miller, 1988, pp. 244-249) In 1960, airlift contracts were tied to CRAF

participation for the first time, and better CRAF arrangements were developed. CRAF carriers would be given preference over routine channel missions, and MATS would foster cargo carrier growth in both the domestic and foreign markets. (Miller, 1988, p. 273) The airlines would get some level of business, but not all they wanted. In 1960, MATS became Military Airlift Command (MAC).

CRAF has experienced two major modifications since it was established. First, in 1963, the three stages of CRAF implementation were established. Each stage was assigned a number of aircraft and a level of authority necessary to activate it. Stage I was established to handle a lesser regional conflict; Stage II for a major regional conflict; and Stage III for a national emergency or two major regional conflicts. Second, in 1969, responsibility was transferred from the Department of Commerce to the Department of Transportation with the creation of the latter agency. (Becker, 1989, p. 14)

From 1965 to 1970, the Joint Chiefs of Staff severely restricted airlift; however, 80% of MAC's aircraft were dedicated to the Vietnam War. MAC averaged 44 military and 29 civilian contract flights per day into Southeast Asia (SEA). The 1970 airlift doctrine stated that large-scale deployments would be out of the question without CRAF. CRAF would carry large numbers of people and bulk cargo between major air terminals for further transport to the front. (Miller, 1988, pp. 336-338)

In 1966, the C-141 Starlifter revolutionized aeromedical evacuation by providing a high-speed, long-range, large-cabin-capacity intercontinental jet for patient transport. The C-141 could hold 103 litters with 14 additional seats. This was crucial during the Vietnam War, and the use of propeller-driven aircraft diminished during this time period.

In 1968, the C-9 Nightingale, based on the Douglas DC-9, was introduced and provided more capabilities for specialized patient care than any previous aircraft. The C-9 which remains the only USAF aircraft specifically designed for moving patients, can carry 40 ambulatory and 4 litter patients, 40 litter patients, or a combination thereof.

A hydraulically operated folding ramp allows efficient loading and unloading of patients (USAF Fact Sheet 92-42). The C-141 and C-9 enabled jet aeromedical evacuation.

(Davis, 1986, p. 21)

In the late 1970s, a military exercise identified a serious shortfall in aeromedical evacuation capability in wartime. This resulted in a Joint Chiefs of Staff tasking to examine expanding the CRAF program to include AE. (Wilhite, 1996, p. 7)

1. Comparison to CRAF Enhancement Program

In 1975, cargo requirements were diminishing as the Vietnam era came to a close. The end of that conflict prompted the civil cargo carriers to approach Congress and DoD looking for more business (House Committee on Armed Services, 1975, p. 179). This led to the CRAF Enhancement Program (CEP). CEP involved strengthening the floor of selected aircraft and widening the cargo door, adding weight and increasing operating costs. The first CEP contract went to modify a United Airlines (UA) B-747 in 1980. It took two years to complete and cost \$27.5M, split between UA and MAC. UA was reimbursed for anticipated increased operating expenses. This version of CEP was limited to new aircraft coming off the assembly line. The program was not very successful due to a lack of other incentives and because almost no U.S. carriers were purchasing aircraft at this time due to a recession. The second version of CEP resulted in a 1983 contract

with Pan Am for 19 existing aircraft to be modified; that work was completed in 1990 at a cost of \$532M. In the third iteration of CEP, MAC would pay for the installation and increased operating costs due to increased weight as long as the carrier agreed not to use the conversion features in peacetime.

MAC did not want to pay for enhancements that the carriers would utilize for increased revenues, and it wanted the enhanced aircraft available for activation. This involved a 12-year commitment of the aircraft to CRAF. FedEx modified two and Evergreen one aircraft. (Wales, 1998, p. 26) After the Gulf War, Pan Am went bankrupt (1991) and MAC lost access to 14 of the 19 modified craft. Congress decided that CEP was not cost-effective—pay for 23 and get nine—and canceled funding. CRAF eventually convinced the new owners of the 14 Pan Am conversions to participate in the program. Of the 23 CEP aircraft, 15 are in service, two are in storage, and one was lost over Lockerbie, Scotland. The remainder of the kits the Air Force procured for this program are offered for free to airlines if the aircraft is obligated to CRAF. (Donovan, 1996, p. 52) Evergreen modified one more, which is currently in service as well.

In 1986, the Aeromedical Evacuation (AE) segment of CRAF was conceived:

On November 17, 1985, CINCMAC proposed to the Secretary of the Air Force that a segment of the CRAF be dedicated to aeromedical evacuation of casualties to and within CONUS. On March 12, 1986, the Office of Emergency Transportation within the Department of Transportation approved the inclusion of aeromedical evacuation in any future Memoranda of Understanding on the CRAF. On May 28, 1986, the Office of the Secretary of the Air Force, acting as the Department of Defense (DoD) single manager for airlift, approved the aeromedical evacuation segment of the CRAF. (Bouchard, 1994.)

At that point, it was determined that the Air Force organic AE capability would be insufficient due to aging aircraft with no foreseeable replacements. The C-141s and C-5s were approaching the end of their useful life. C-17 Globemasters were being procured, but not at a one-for-one replacement rate. The C-17 could hold only 48 litters and 54 ambulatory patients. (C-17 Globemaster III Fact Sheet) The C-9s would have to be modified because they did not meet noise abatement regulations and did not have Global Air Traffic Management (GATM) installed. GATM is used to reduce the vertical spacing of aircraft. There is a study underway to evaluate the economic feasibility of retaining the C-9s. In addition to the necessary modifications, the anticipated cost of maintaining these aircraft is rising because the commercial sector is retiring its DC-9s. (Edwards, 16 February 2000, e-mail)

The original interim plan to satisfy the AE mission was for airline passenger planes to fold the seats forward, place 4"x4" lumber across the seats, strap these to the seats and place litters on top and strap those to the lumber. While this would require a higher stabilization of patients, any commercial passenger aircraft could be used. The lumber and cargo straps were purchased and staged at key Air Force bases. Meanwhile, the Aeromedical Evacuation Ship Set (AESS) was designed, contracted for and finally produced in 1990. The main components of the AESS, which was to be installed in a Boeing 767 aircraft, were a therapeutic Liquid Oxygen Support System (LOSS), 60 Hz electrical power pallet, Nurse's station and litter stanchions. (Priddy, phoncon, 28 Jan 2000) See Figures 1-3.

Although the AE mission does not require a permanent alteration to the aircraft, it, like the CEP program, is burdensome to the airlines. The AE mission segment is significantly riskier than the passenger or cargo missions in both the financial and aircraft arenas because the aircraft must be baselined (removing the seats, galleys and lavatories) and the AESS installed. Similar to the CEP program, AE receives less than enthusiastic support from Congress and lukewarm support from the airlines, as will be discussed further below.

2. Lessons Learned from Recent Operations

In 1983, the Secretary of the Air Force and the Air Force Chief of Staff released the U.S. Air Force Airlift Master Plan, which stated that the Air Force would retain a minimum of 11.3 Million Ton Miles/Day (MTM/D) and 144.9 Million Passenger Miles/Day (MPM/D) of airlift capacity in the CRAF program (Gabriel and Orr, 1983, p. V-8). On 6 July 1987, President Reagan signed National Security Decision Directive-280, reiterating the importance of CRAF to the national defense. The airlift doctrinal heritage of the modern era states that civil cargo and passenger aircraft augment military airlift aircraft; they are not a replacement for military airlift aircraft (Miller, 1988, p. 415).

On 17 August 1990, during the Gulf War, President Bush activated CRAF for the first time since its creation in 1951. CRAF provided 62% of the required passenger lift during deployment and 84% of that required during redeployment for Operation Desert Storm (ODS). CRAF also provided 27% of the cargo lift for deployment and 40% for redeployment (Coffey, 1996). CRAF added 17 passenger and 21 cargo aircraft in Stage I, followed by CRAF Stage II with 117 aircraft bringing the total to 155. This accounted

for 31% of the 500 aircraft available under stage III CRAF activation (Ryan, 1993, p. 6). ODS total airlift was 5% of the total tonnage (543,000) by air a distance of 7000 NM sustained for 203 days totaling 15,600 missions, with only one transport and 12 military crew members lost (Gebman, et al, Vol. 2, 1994, p. 23).

Small carriers supplied (volunteered) five times the number of aircraft required. The small carriers were fairly adept at arranging backhauls from Europe to increase profitability. Large carriers supplied requisitioned aircraft only, except that Delta volunteered one, and PanAm and TWA volunteered eight (both were either in or near bankruptcy and the War disrupted their market). Most flew back empty. The large carriers were reluctant to participate because giving up aircraft would mean most probably losing market share in the very competitive airline passenger market. (Gebman, et al, Vol. 2, 1994, p. 53) In fact, Stage II should have been activated earlier, but was put off until after Christmas because the carriers were lobbying the President. When Stage II was finally activated, the backlog warranted more than Stage II; however, only Stage II was activated due to the negative economic impact on the major carriers. Korea, Italy, Luxembourg and The Netherlands also provided airlift. Japan would not provide aircraft, but paid for more than 100 B-747 missions (Priddy, 1993, p. viii).

DoD's airlift capacity estimate before ODS was 49 MTM/D. The highest realized during ODS was 19 MTM/D. Several factors contributed to this: CRAF successfully resisted full activation for cargo; there were inefficiencies in scheduling airlift; and the planning factors used to assess capabilities were too optimistic. (Gebman, et al, Vol. 1, 1994, p. 14)

B. CURRENT REQUIREMENTS

Currently, in a national emergency CRAF (over 700 commercial aircraft) would carry 95% of the passenger requirements and 25% of cargo. CRAF is divided into five mission segments:

1. Short-range international—Aircraft selected for allocations are medium-range aircraft, capable of flying a distance of 1500 nautical miles non-stop. These aircraft must be equipped for overwater operations and are used for strategic airlift from the continental US (CONUS) to short-range offshore destinations, and for theater airlift within specific geographic areas requiring airlift. (Passenger and cargo segments.)
2. Long-range international—Aircraft selected for allocation are long-range aircraft, capable of flying a distance of 3500 nautical miles non-stop. These aircraft must be equipped for extended overwater operation and are used for strategic airlift between the CONUS and overseas theater of operation. (Passenger and cargo segments.)
3. Aeromedical evacuation—Aircraft currently eligible for allocation must be B-767 extended range for the international aeromedical requirement. (Green, 1999)
4. & 5. National—Aircraft selected for allocations are medium-range passenger and cargo aircraft with a minimum unrefueled range of 1,500 Great Circle Statute Miles (GCSMs)...Aircraft can be used for airlift to/from CONUS to short range offshore or intra-island destinations (Alaska, the Caribbean, or Hawaii), and for North American airlift within specific geographic areas requiring airlift. (Alaskan segment and Domestic Services segment) (Deutschmann, 1999)

There are three stages in CRAF:

Stage I—Committed Expansion. Stage I may be activated for a lesser regional contingency or other situation when AMC organic airlift resources cannot meet both deployment and other airlift requirements simultaneously.

Stage II—Defense Airlift Emergency. Stage II is for a single major theater war or other contingency causing substantially increased AMC airlift activity.

Stage III—National Emergency. Stage III is activated for multiple major theater wars or other emergencies requiring mobilization of all DoD resources or the total

CRAF airlift capability when required for worldwide emergency operations involving U.S. military forces. (Green, 1999)

What follows are AMC's requirements for fiscal year 2000:

	LONG RANGE REQUIREMENTS		
	<u>STAGE I</u>	<u>STAGE II</u>	<u>STAGE III</u>
Cargo WBE*	30	75	120
Passenger WBE	30	87	136

	AEROMEDICAL EVACUATION REQUIREMENTS	
	<u>STAGE II</u>	<u>STAGE III</u>
Aeromedical B-767 Aircraft	25	40

	SHORT-RANGE REQUIREMENTS	
	<u>STAGE II</u>	<u>STAGE III</u>
Cargo SRE**	18	71
Passenger SRE	13	29

*WBE is a Wide Body Equivalent or B-747-100 standard.

**SRE is a Short Range Equivalent or B-727-100 standard. (Green, 1999)

	NATIONAL REQUIREMENTS	
		<u>STAGE III</u>
Cargo#		25
Passenger##		30
#16 short tons is the standard.		
##75 passengers is the standard. (Deutschmann, 1999)		

AE aircraft must have certain features to provide an adequate level of patient care during transport. Normal "people" features include: cooling and heating, pressurization, lavatories, galley, sound insulation and cabin lighting. All commercial passenger aircraft have these amenities. Medical features include: 60 Hz, 115-VAC power at each litter, therapeutic oxygen at each litter, emergency oxygen for patients and crew, medical storage area, medical crew seating, litter support system. (Thomas, 1985, p. 24) The CRAF Aeromedical Evacuation Ship Set (AESS) includes all of these.

Following ODS, CRAF was reviewed; at the time, all of the AE and CEP requirements were in Stage III. AE has since been modified to 25 aircraft in Stage II and 40 in Stage III. The requirement for AE has fluctuated from 13 to 115 aircraft and seems to be an ever-moving target depending upon whom is computing it (Wilhite, 1996, p 23). The current requirement of 40 aircraft is derived from the regional Commanders-in-Chief (CINCs) input to the Joint Staff for inclusion in the Defense Planning Guidance. The required number of aircraft was not attained in the program until fiscal year 2000.

CRAF is an annual voluntary contractual relationship between the airlines and the U.S. government based on a package of business incentives. The business incentives include: City-Pairs, Civilian Access to Military Installations (CAMI), Contingency Alert and Small Package programs. GSA City-Pairs includes government travel by all federal agencies with an annual volume of approximately two billion dollars. CAMI permits airlines to select military airfields as preplanned weather alternates and unplanned technical stops. Under CAMI, airlines would save on fuel to meet FAA safety requirements for diversion. Cargo carriers would also be interested in alternate low-cost terminal sites (Post, 1996, p. 31). The Contingency Alert concept compensates carriers for administrative functions prior to CRAF activation in support of a contingency. Previously, if activation was not initiated, the airlines incurred additional costs in preparing for activation, which DoD did not reimburse. The Small Package program for next-day and two-day package service is also tied to CRAF. If an airline (cargo or passenger) wants any of the government travel or cargo business, it must commit a minimum of 30% of its passenger fleet or 15% of its cargo fleet to CRAF. The current

package of business incentives was not enough to attain full commitment until this fiscal year. (Halbert, 1999)

Government business is allocated to the airlines based on their percentage of Mobilization Value Points (MVPs). MVPs are calculated based on the standard of a B-747-100 aircraft or Wide Body Equivalents (WBE). The Million Ton Miles (MTM) rate of a B-747-100 is computed by multiplying the Block Speed (BS=465 knots) by the payload in tons of cargo (PL=78 tons) by the Productive Utilization Rate (PUR=4.7 hours/day) and dividing that by one million which equals .170469. The Million Passenger Mile (MPM) rate would be the same equation, except that the PL would equal 325 passengers, resulting in .71029. The MTM/MPM rates for the aircraft the airlines wanted to commit to CRAF would be derived and that number would be divided by the B-747-100 rates calculated above. The WBE rates of each aircraft would be totaled to obtain the MVPs for each airline. Bonuses for MD-11, B-747-400 and B-777 aircraft are added at 20% and double MVPs are added for Stage I aircraft and AE (Summary of MVP Calculation, 1999, Briefing slides). The airline would be allocated the percentage of business that correlated with its percentage of MVPs. The AE portion of CRAF has added incentives, including: 1) the points are transferable; and 2) AE patrons are the only ones that can sell their points for cash (Green, 1999, pp. C-3, M-5).

The airlines can form teaming arrangements. As of fiscal year 2000, there are four teams and six independents. The Federal Express team consists of: Federal Express, Polar Air Cargo, Air Trans/BAX Global, Gemini, Northwest, American, United, Delta, American Trans Air and Tower Air. The World Airways team consists of: World

Airways, Continental, TWA, US Airways, North American, Evergreen, Emery, UPS and Kitty Hawk International. Alaska Airlines team members are Alaska Airlines and Miami Air. Arrow Air team members are Arrow Air and Fine Airlines. The independents are: DHL, Sun World, Lynden Air Cargo, Omni Air Express, Spirit Airlines and Hawaiian Airlines. Teams combine their MVPs in order to get a larger percentage of the business. (Introduction to the Civil Reserve Air Fleet Briefing, 1999)

Team members can sell points within the team. The only exception is that AE carriers can sell their points to any CRAF participant. For example, a large scheduled passenger carrier may have a large number of points. That carrier, however, is not interested in flying government charter missions and can sell its points to a charter carrier. Buying points eats into the charter carriers' profits, but without the extra points, they would not receive as much business. The only disincentive to joining a team is joint and several liability, which becomes an issue if a team member defaults on a government mission. All of the team members are then liable for the difference in cost for the government to acquire substitute service. (Halbert, phoncon, 18 February 2000)

C. SUMMARY

This chapter detailed the history of both CRAF and AE. CRAF is here to stay, as it is just not economically feasible for DoD to obtain and maintain the aircraft necessary to fulfill these requirements. AE will exist as long as the U.S. has service members deployed throughout the world and the threat of war exists. The next chapter will detail some of the current issues with the CRAF AE program.

A/A99S-3, CONVERSION SET, AIRCRAFT MISSION
 INSTALLATION/INSTRUCTION MANUAL.

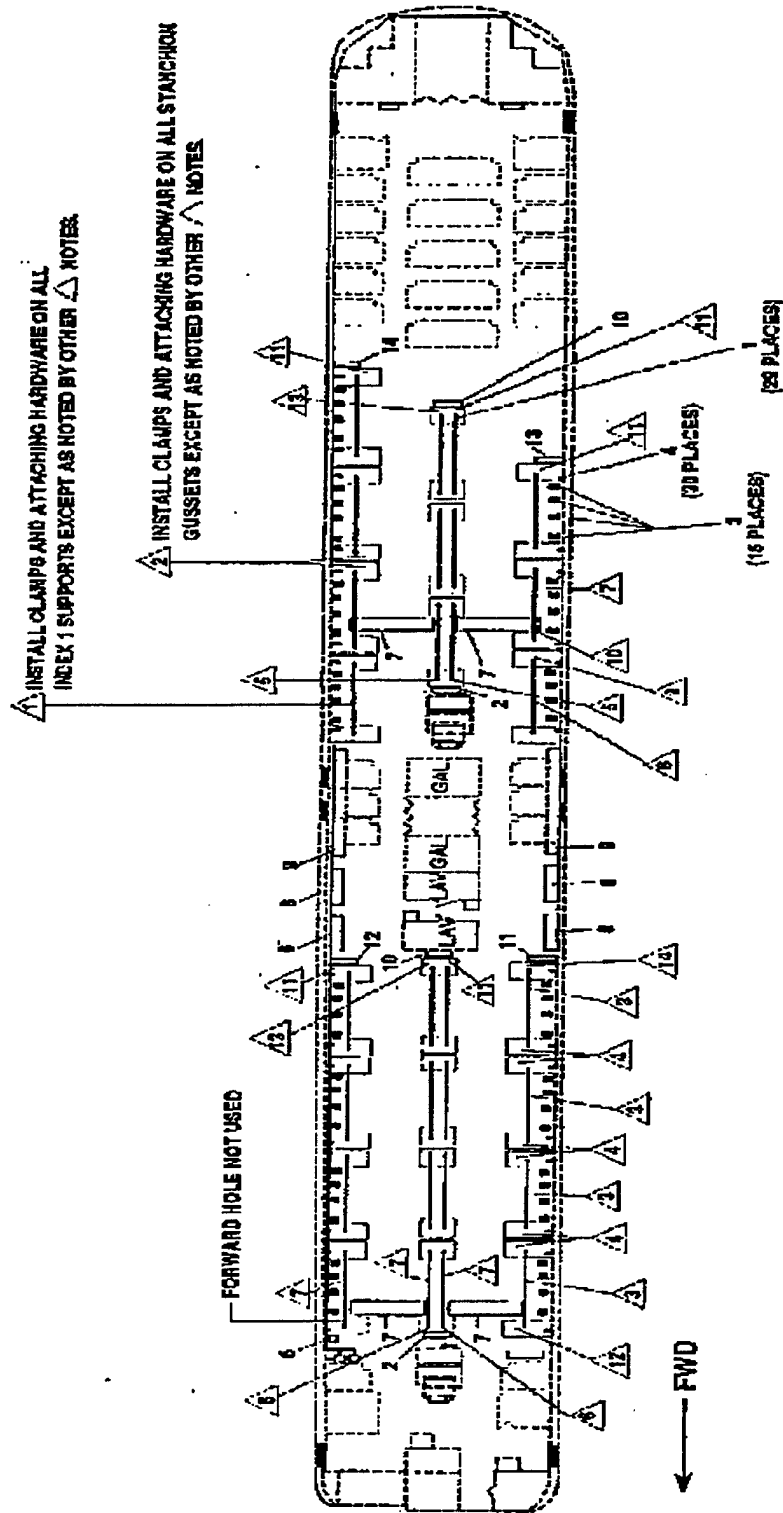

B767-300 87 LITTER INSTL

TP143

Figure 1. B-767-300 AESS Drawing for 87 Litter Installation [From Ref. A/A99S-3, Conversion Set, Aircraft Mission Installation/Instruction Manual, 1992, p. 2-45]

A/A99S-3, CONVERSION SET, AIRCRAFT MISSION
INSTALLATION/INSTRUCTION MANUAL

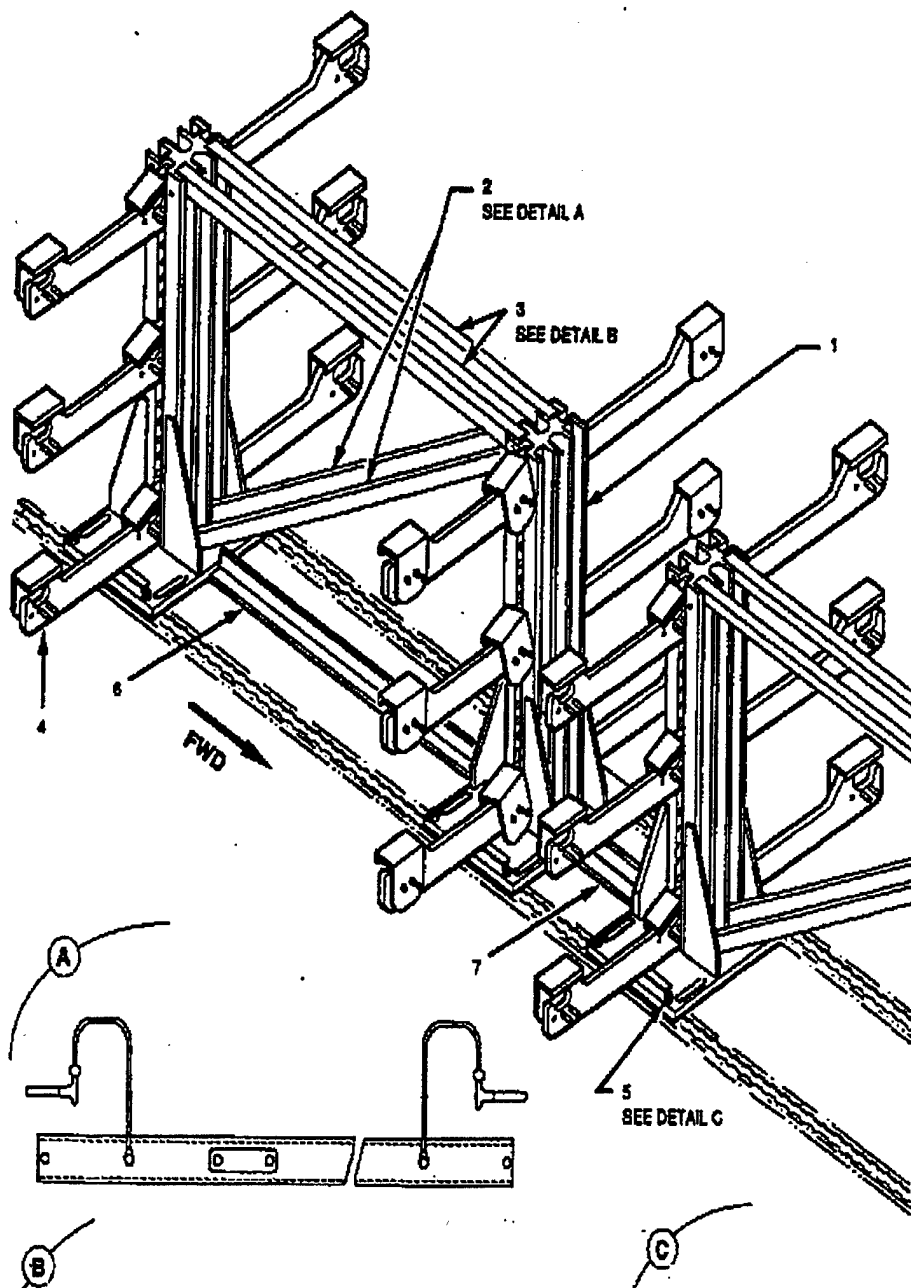

Figure 2. Paired Double Stanchion Assembly for Litters Portion of AESS [After Ref A/A99S-3, Conversion Set, Aircraft Mission Installation/Instruction Manual, 1992, p. 2-33]

**A/A99S-3, CONVERSION SET, AIRCRAFT MISSION
INSTALLATION/INSTRUCTION MANUAL**

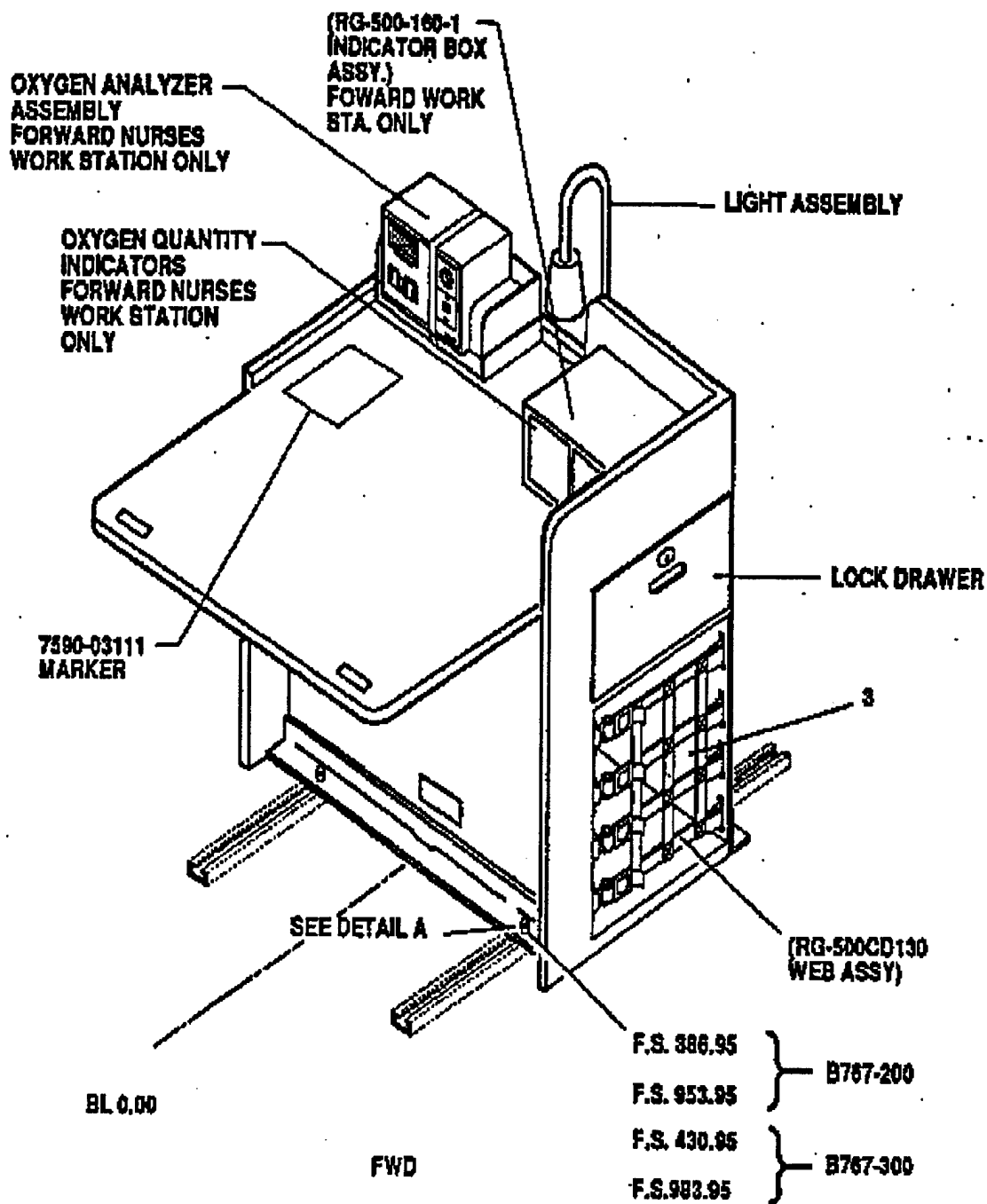

Figure 3. Nurse Station Assembly Portion of AESS [After Ref. A/A99S-3, Conversion Set, Aircraft Mission Installation/Instruction Manual, 1992, p. 2-56]

THIS PAGE INTENTIONALLY LEFT BLANK

III. ISSUES

The Air Force is trying to determine what an adequate incentive package would be to attract more airlines to the CRAF AE program and to get the total number of aircraft required. USTRANSCOM is currently considering extending the CRAF AE mission segment to include the In-CONUS Movement of Patients (ICMOP) due to lack of organic assets to accomplish this mission. If this were to occur, a requirement for an additional 28-42 AE aircraft would exist (Combs, 21 Oct 1999, e-mail).

A. CURRENT CHALLENGES

DoD is looking to reduce the number of B-767-200ERs and B-767-300ERs required for AE. The carriers find it difficult to commit these aircraft because they are essential to profitability and because of problems with the AESS, which will be discussed below. DoD has also investigated including DC-10s in the program because carriers are reluctant give up their newest B-767s (U.S. General Accounting Office, 1996, p. 3). The USAF has decided to stay with the B-767. Although the DC-10 would be the next best airframe, many of them are being retired now. The assumption that, because the AE program exists and B-767s are the designated aircraft, full commitment of the aircraft by the airlines will be achieved, is faulty. In 1995, there were 19 aircraft committed to AE. As of January 1999, 36 aircraft were committed--16 from Delta Airlines, nine from TWA, and 11 from US Airways (Medigovich, 1999, p. 2, Encl. 1). As of fiscal year 2000, there are 36 from Delta, ten from TWA and 12 from US Airways totaling 58 aircraft committed to AE.

United Air Lines and American Airlines have the largest number of B-767 aircraft in their fleets, but neither airline has committed aircraft to the AE program. Their major

concern is the location of the Liquid Oxygen Support System (LOSS), which is discussed in further detail below. United Air Lines also expressed concern over the effects of AE missions on its Extended Twin Engine Operations (ETOPS) rating. United is concerned that mission aborts would count against its rating (Wilhite, 1996, p. 32). The Federal Aviation Administration (FAA) ruled that mission aborts due to AE would not count against the rating; however, United still has reservations. For the 1999 contract, Delta considered withdrawing from the program, and USAF re-negotiated rates to retain its commitment (Lamontagne, 1999). Delta is again considering withdrawal from the program.

1. Supplemental Type Certificates

FAA must grant a Supplemental Type Certificate (STC) for each configuration of the AESS and aircraft (Wilhite, 1996, p. 15). Delta, TWA and US Airways have slightly different configurations of their B-767-200ERs and B-767-300ERs. The USAF completed FAA certification of all of Delta's aircraft in 1999. TWA and US Airways currently have no aircraft certified. USAF hopes to fund three STC configuration approvals per year. (Lamontagne, 1999)

2. Corrosion

TWA has voiced concern over corrosion discovered while baselining the aircraft. Under the conditions of the CRAF AE agreement, the airlines have 48 hours from notification of activation to remove the seats, galleys and lavatories from the planes and deliver the aircraft to Raytheon E-Systems in Texas for installation of the AESS. Areas under the lavatories and galleys, which are prone to corrosion, are normally checked during a maintenance "D-check" every six years. If the area is opened and corrosion is

evident, FAA regulations require immediate repair, and the aircraft are grounded until the repairs, which may take up to six days, are complete. In such a case, the airline cannot provide the aircraft in the 48 hours required; the airline will default on the contract and may be penalized by DoD. If the activation does not coincide with the timing of the D-check, then the airline incurs additional unanticipated maintenance costs. (Simmons, 1999, phoncon)

3. Liquid Oxygen Support System

American Airlines and United Air Lines appear to be concerned about the Liquid Oxygen Support System (LOSS) that is part of the AESS onboard the plane. This is the only liquid oxygen system approved by the FAA for transport by air (Lamontagne, 1999). Liquid oxygen is forbidden for transport by International Air Transport Association regulations, according to a Federal Express Dangerous Goods Customer Service Representative consulted on 12 March 1999. The airlines' concerns include: having a pressurized container onboard the plane (missile hazard); whatever liquid oxygen touches becomes brittle (structural difficulties); and the airlines' maintenance crews are not familiar with the system and not trained to service it (Simmons, 1999, e-mail). In addition, the LOSS is located in the forward cargo bay of the aircraft just aft of the flight deck, where vital systems for the aircraft are located. United and American are concerned about the proximity of the LOSS to vital systems and the possibility of losing the aircraft in the event of a casualty in the LOSS.

There are six dewars, which are round, pressurized vessels that hold the liquid oxygen, mounted on a pallet and stowed in the forward cargo bay as part of the LOSS. Currently, Raytheon is submitting an Engineering Change Proposal (ECP) to the USAF

Contracting Officer to redesign a wire indicator that is failing inside the dewars. The new design utilizes load cells to measure the liquid oxygen by weight rather than with wire indicators. Because of safety concerns and the criticality of this system, the FAA and the Food and Drug Administration (FDA), which regulates medical equipment, must approve any modification. Also, the dewars can be repaired only once before decertification by the FAA. (Combs, 5 January 2000, e-mail)

4. Aeromedical Evacuation Ship Sets (AESS)

The AESS modifies the B-767 to carry 87 litter patients, 20 to 40 ambulatory patients, and medical crew. The AESS provides oxygen and electricity to each litter. The original medevac kits for the B-767s were flawed and required modification. The AESS was unsupported in front of the enlarged cargo door. Eleven of the 44 sets remain configured for narrow cargo doors and have not yet been modified.

Upon activation under Stages II and III, Delta, US Airways, and TWA are to move their aircraft to Greenville, Texas within 48 hours for reconfiguration by Raytheon. It is anticipated that three planes will be reconfigured and positioned in-theater within 36 hours, with three additional planes every 12 hours thereafter. Assuming two days to activate the CRAF, 48 hours to deliver aircraft to the modification contractor, and 36 hours for modification, testing and movement to the theater, thus it will take five days for the first aircraft to be delivered and nine days to reach the Stage II strength of 25 aircraft. Stage III strength would not be reached until 11 days after the original CINC request. (Combs, 6 October 1999, e-mail)

Currently there are 30 complete AESSs operational. (Combs, 5 January 2000, e-mail) This obviously meets neither the 40 aircraft required, nor the 58 aircraft under

contract. Repairing and maintaining the original 44 AESSs purchased is a higher priority at this point than purchasing additional AESSs. Also, every different aircraft configuration must have a kit with parts to adapt the AESS to fit. (Combs, 7 January 2000, e-mail)

The process to reconfigure the planes has a few glitches to be worked out. The General Services Administration (GSA) warehouse holding the AESSs is open only from 0600 to 1800, Monday through Friday, and closed nights, weekends and holidays. The AESSs must be transported from Fort Worth, Texas to Greenville, Texas, a distance of approximately 85 miles, for installation. The procedure for contracting a trucking firm or purchasing trucks does not appear to have been finalized. The airlines have 48 hours to deliver their planes to Greenville, and RSC has 12 hours to install the AESSs in the first three planes. Also, Greenville has enough fuel available for the first three planes; after that, fuel must be contracted for and delivered by truck to the site. These hurdles must be dealt with so activation is not nearly as painful as it might be. (CRAF AESS CLS Program Management Review, 28 September 1999)

5. Casualty Transfer System

Prior to 1999, total AE capability was affected by the lack of a viable patient loading system. A Casualty Transfer System (CTS) was used to load patients onto the aircraft, but not required at an airport that has jetway capability. A new patient loading system (PLS) was developed in 1998. (US Dept. of the Air Force, 1997, p. 5-57)

A description of the pre-1998 CTS follows:

The CTS is made of plywood and canvas. It consists of a five-pallet train assembled into a stable platform and locked into position on a 40 or 60 K-loader. The K-loader then performs as an elevator between ground level and the airplane door. The CTS has six litter stanchions,

three per side; each stanchion holds four litters, thus the CTS can hold 24 litters total. Each litter position has an IV holder. There is a ramp at the airplane end of the CTS to compensate for difference in height between the K-loader and the airplane doorsill. The canvas serves as a cover at either end of the CTS to minimize the effects of weather....Furthermore, only six CTSs exist; all are located on the east coast, none are situated on the west coast. (Wilhite, 1996, pp.39-40) [See Figure 4 for a picture of the CTS]

Under the previous system, patients were transferred from the ambulance by medical personnel to the CTS. Medical personnel would fill the CTS to capacity, raise it to the level of the aircraft, and then unload the patients. This was an awkward and time-consuming process.

A description of the current PLS follows:

The Patient Loading System (PLS) is a specialized aluminum ramp that is used for enplaning and deplaning of ambulatory and litter patients on Boeing 767 aircraft activated as part of the Air Force's Civil Reserve Air Fleet (CRAF). The PLS will also interface with the KC-135 aircraft.

The ramp allows patients to be loaded from the ground level to the forward passenger door level of the B-767 and forward cargo door of the KC-135 aircraft.

The PLS can be assembled or disassembled by four (4) Air Evacuation Crew Members (AECMs) or Aeromedical Staging Squadron (ASTS) personnel within 2 ½ hours. It can be reconfigured from the B-767 to the KC-135 configuration, or vice versa, within ½ hour.

The PLS ramp is stored and transported in two reusable, stackable containers. (User Manual, p. 1) [See Figure 5 for an illustration of the PLS]

This is a much simplified process compared to the CTS. The 48 PLSs would be distributed as follows: four at Ramstein, Germany; two at Andersen Air Force Base (AFB), Guam; two at Yokota AFB, Japan; two at Hickham AFB, Hawaii; two at Elmendorf AFB, Alaska; two at March Air Reserve Base (ARB), California; two at Travis AFB, California; two at MacDill AFB, Florida; two at Scott AFB, Illinois; two at

Andrews AFB, Maryland; two at Kelly AFB, Texas; and 24 in the warehouse in Fort Worth, Texas. (Marks, 1999, e-mail)

The cumbersome CTS has been replaced by the simpler PLS. The quantity of systems procured appears to be sufficient and they are pre-positioned to improve responsiveness. Mobility of the systems is greatly increased. This issue appears to be resolved.

B. INDUSTRY PERSPECTIVE

As discussed previously, United Air Lines and American Airlines have B-767s in CRAF that are not committed to the AE program. Both United and American expressed two main objections with the AE program as it stands now. First, installation of the AESS is too risky: the 48 hours specified to baseline the aircraft is overly restrictive; and the LOSS is located in an extremely vital area of the aircraft (electrical and engineering systems) where a malfunction of the oxygen system could prove catastrophic. Both carriers anticipate a pilot relations problem resulting from installing this system in this area. In addition, the two airlines view tracking the seats and other parts removed from the aircraft is an administrative burden. Second, time out of service, from baselining to reinstallation of carrier fixtures, is extensive. In the passenger and cargo segments, the aircraft are free to pick up revenue passengers or cargo, once they have completed their assigned mission. An aircraft with an AESS installed cannot be used for revenue generation.

One AE carrier representative suggested three ways to encourage others to participate in AE: 1) develop AESSs for alternate airframes; 2) conduct studies on the LOSS to make carriers less uneasy; and 3) provide a longer baseline timeframe. He

stated that there are no statistics or studies on the use of the LOSS or results from a failure in the LOSS system. This makes carriers very uncomfortable, since this is the only on-board oxygen system authorized by the FAA. There is a feeling within the industry that the government is trying to hide something bad by not publishing data on the system. Another AE carrier official suggested: 1) assigning increased revenue values in Mobilization Value Points (MVPs) and during activation; 2) moving the LOSS to the tail; and 3) providing a longer baseline timeframe. The carrier's representative stated that he did not think that double MVPs covered the risk. He also said that, while being able to sell points is a good thing, with teaming arrangements it is less of a good deal. The official stated that a benefit to teams is shared liability. Also, MVPs are not as big an incentive as they were previously due to the programs now being oversubscribed.

An official from another AE carrier stated that his company originally got into the AE segment for patriotic reasons, but is still there due to double MVPs. He expressed frustration with AMC's lack of responsiveness and DoD's inadequate dialogue with the airlines. The official added that carrier concerns are not addressed and that change takes a tremendous amount of time. He is still looking for answers on the weight and balance of the AESS in the airframe, and he believes that ballast is needed in the front of the aircraft.

The official stated that the basic contract format used by the GSA has not changed since 1982 and the format corresponds to archaic business practices. He expressed dissatisfaction with the recent change to the City Pairs GSA contract, which made reservists travelling to weekend duty stations eligible for discounted government fares, and stated that it happened because DoD lobbied Congress.

The official would also like to see capacity control with GSA getting a maximum percentage of the seats on the plane, rather than the current "last seat availability," under which GSA gets as many seats on the plane as are available. He believes that, in most cases, the government can plan its trips ahead, and the airline could sell that seat to a full-fare business traveler, increasing airline revenues. The official does not believe that the increased compensation for the activation period is adequate when compared to the passenger segment. He suggested that other airlines could be enticed into the program by triple or quadruple points. The official believes that including other airframes would be detrimental to the program and that mandating participation in AE would result in a rebellion by the airlines.

An airline industry association official suggested that, to get more airline involvement, the government could do two things: 1) tie AE to the GSA City Pairs contract or 2) unilaterally designate all B-767s in service to be AE aircraft. He expressed the view, however, that he saw no reason to change the program since it was currently oversubscribed. He doubted the marginal utility of enrolling more airlines into AE, citing the expense of STCs and the lack of AESSs as his reasons.

C. SUMMARY

This chapter introduced the issues to be considered more fully in the next chapter. If solutions to these issues can be devised, then industry participation in the CRAF AE segment would likely increase. Airline industry views were obtained because there was no literature on CRAF or the AE mission written from that perspective. There were a large number of government-sponsored studies and military theses on the topic, but

nothing from an industry perspective. It follows that, if increased industry participation is desired, a conversation with industry should occur.

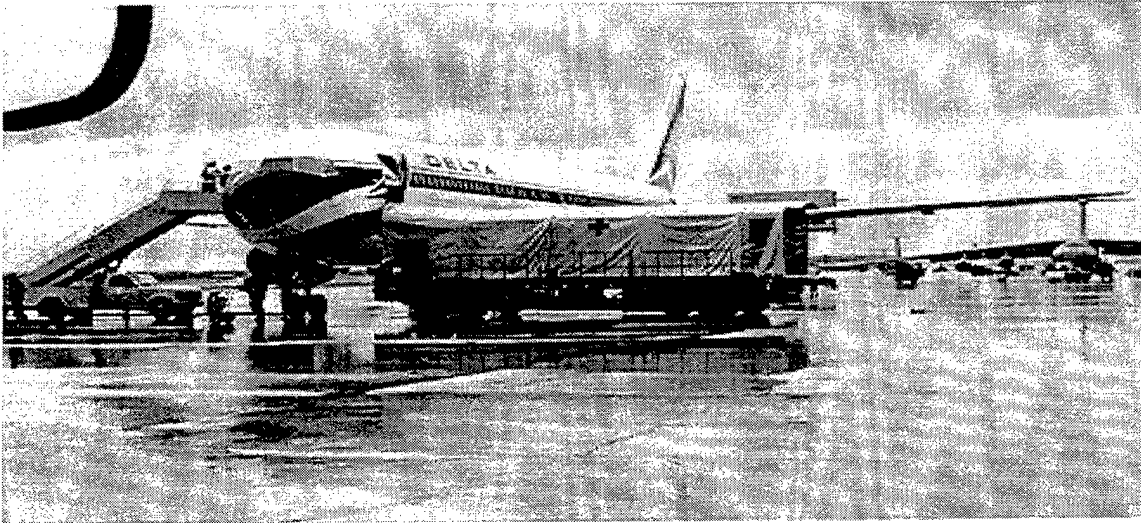

Figure 4. Photograph of Casualty Transfer System (CTS) Next to a B-767 [From Ref. Edwards, 15 February 2000, e-mail]

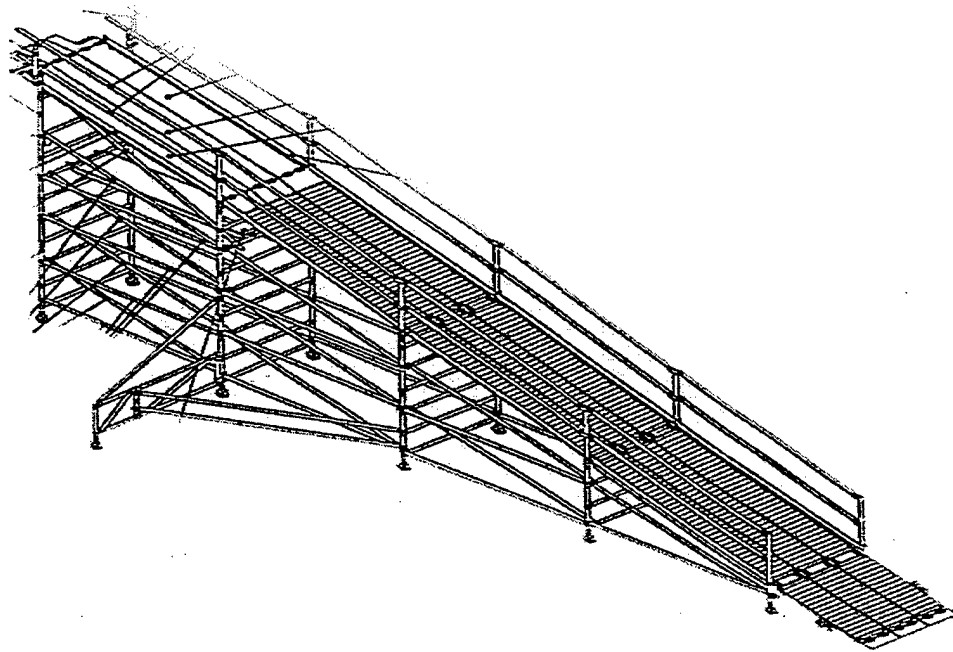

Figure 5. Patient Loading System (PLS) [After Ref. User Manual Patient Loading System (PLS), p. 9]

IV. FINDINGS AND RECOMMENDATIONS

This chapter provides findings and recommendations based on the information gathered and potential areas of improvement in the AE segment of CRAF.

A. CURRENT CHALLENGES

If AMC's goal is to increase airline participation in the AE segment of CRAF, then mitigating some of the risk incurred by the airlines should aid in accomplishing this goal. What follows are some suggestions on improving the program.

1. Supplemental Type Certificates (STCs)

Currently, only Delta has aircraft that have STCs and are authorized by the FAA to carry out the AE mission. This means that, even though the AE mission segment is oversubscribed in fiscal year 2000, there are still not enough aircraft with STCs to fulfill the requirement. If the funding remained in place for the approval process of three STCs per year, as previously planned, this issue would eventually resolve itself (Lamontagne, 1999). The current plan is to shift the STC funds to cover the LOSS repair, which will delay STC resolution (Combs, 25 Feb 2000).

Recommendation: a. AMC should continue to fund STCs and communicate the importance of funding STCs to USTRANSCOM and the Secretary of Defense during budget calls and at every other opportune moment.

b. AMC should also verify if the FAA would require an STC to utilize the 4"x4" lumber and cargo straps on passenger carriers. If not, then AMC should verify whether the lumber and cargo straps are still warehoused and devise an alternate plan to achieve the required number of aircraft for the AE mission.

2. Corrosion

If corrosion is found during baselining the aircraft, the aircraft is grounded. FAA regulations require that a maintenance "D" check be performed to correct the situation.

Because a "D" check takes six days to complete, the airlines will default on the requirement to have the aircraft in Greenville within 48 hours.

There are two possible ways to alleviate the risk to the airlines. First, AMC could request a waiver from the FAA for the duration of the activation period. During the Gulf War, AMC requested a waiver for crew flying time that the FAA approved, so there is a precedent for this type of action (Priddy, 1993, p. 101). Upon removal of the AESS at the completion of the activation period, the repairs could be accomplished. If the airlines could deliver on time, they would not default on the contract and suffer any penalty.

Recommendation: AMC should request that the FAA establish procedures for granting waivers for corrosion repairs to CRAF AE aircraft which are baselined upon activation, the waivers to remain in effect while the aircraft is required by AMC. The nature of the waiver would depend on the type of corrosion encountered and the length of the planned activation.

The second way to alleviate the risk to the airlines if corrosion is found would be for AMC to pay the airlines for an additional six days of activation to compensate the airlines for the unplanned maintenance cost. If the airlines provided a different aircraft, they would have two of their aircraft out of revenue service. AMC is not very interested in this idea of additional compensation as it considers maintenance the responsibility of the airlines and does not want to assume any of the financial burden (Delmoral, 1999).

Recommendation: AMC should develop a compensation package that specifically addresses the additional burden borne by the airlines when corrosion is found during baselining, should an FAA waiver (as recommended above) not be appropriate.

2. Liquid Oxygen Support System

American Airlines proposed that if the LOSS were located in the aft cargo hold away from most of the vital systems, it would consider committing aircraft to the AE

portion of CRAF. As of December 1999, American has 18 B-767-200ERs and 49 B-767-300ERs committed to the passenger portion of CRAF (Office of Emergency Transportation, December 1999). AMC's position is that the LOSS is safe where it is currently located. The current location of the LOSS is approved by the FAA, and AMC will not re-engineer the system. Moving the LOSS would require modifications to the AESS and an additional investment by AMC. There is also a concern with the center of gravity of the plane. If the LOSS were moved aft, ballast of approximately 1000 pounds would have to be added to the forward cargo bay in order to maintain the required weight and balance, which would decrease the distance and capacity of the aircraft.

(Lamontagne, 1999)

If AMC wants to increase participation by airlines, it must decrease the risk perceived by the airlines. The LOSS is unique in that it does not have an operating history; research has not been widely published on the LOSS; and the LOSS is suffering failures in the dewars which contain the liquid oxygen. AMC could lease a B-767 for 30 days, install the AESS, train the Aeromedical Evacuation Crew Members (AECMs) on an operating system, study the system, and publish the results. With some coordination, reservists could be scheduled to pilot the B-767 for the 30 days, which would conserve funds. Funding might be an obstacle to this plan, but both training and research would be gained. An alternative would be to install the AESS in a mock-up; however, unless the mock-up simulates pressure changes from altitude and vibrations and forces normally experienced during take-offs and landings, the benefit derived would be limited.

Recommendation: AMC should lease a B-767, install an AESS and utilize the aircraft for training, data history and research.

AMC needs to find alternatives to the current LOSS system. This could be done through encouraging research at service schools (e.g., Naval Postgraduate School or Air Force Institute of Technology), civilian universities or government or other research organizations. As an example, the Advanced Hybrid Oxygen System (AHOS) is a molecular sieve oxygen generator that can generate liquid or gaseous oxygen. Currently, AHOS has limitations that do not lend it to AE use; however, further development of this system could overcome these limitations.

Recommendation: AMC should sponsor and encourage research on alternative in-flight patient oxygen systems.

4. Aeromedical Evacuation Ship Set (AESS)

Priorities in descending order should be:

repair the failed LOSSs in order to obtain fully operational AESSs;

backfit other LOSSs to prevent continued failures;

ensure that adapter kits for every individual aircraft are complete;

perform preventive or routine maintenance on the AESSs;

reconfigure 11 remaining AESSs for the enlarged cargo door;

then, purchase additional AESSs.

All the above require funding which is more easily obtained with high visibility of the issues. However, since the program has encountered several glitches, high visibility of the program seems not to be desired. In its current state, the AE program will not function effectively, nor as designed.

Recommendation: AMC should develop a detailed plan that describes all the deficiencies, the actions required to eliminate the deficiencies, and funding requirements for the CRAF AE program. This plan should be presented to the Secretary of Defense and USTRANSCOM with a request for funding.

If the AE segment of CRAF is activated after normal working hours, then RSC has no access to the GSA warehouse in Fort Worth, Texas, where the AESSs are stored. RSC needs to move the AESSs from Fort Worth to Greenville in a short time to install them on the B-767s and to make their contractual commitment.

Recommendation: AMC and GSA should negotiate a Memorandum of Understanding (MOU) on access to the warehouse where the AESSs are stored in case of activation. This is not an issue that should be resolved after activation. AMC should have a point of contact at GSA to notify to gain access to the warehouse. GSA should have a contingency plan to staff the warehouse in case of an activation.

The AESSs must be transported from Fort Worth to Greenville to be installed in the B-767s. AMC may be able to avoid the issue of contracting or purchasing trucks to transport the AESSs by having Military Traffic Management Command (MTMC) issue a trucking contract. Under the Contingency Response Program (CORE), pre-allocation of ground transportation requirements and priority is possible. (DODD 3005.7)

Recommendation: AMC should request that MTMC establish an appropriate trucking contract to support the movement of AESSs between Fort Worth and Greenville, Texas. Close coordination between AMC and MTMC should result in MTMC seamlessly arranging the necessary transportation during an activation.

Currently, the Greenville site can supply the first three B-767s with fuel. There are no arrangements in place for the aircraft that follow. The Defense Logistics Agency's (DLA) Defense Energy Support Center (DESC) should be able to arrange for fuel to be delivered to Greenville during an activation (DODD 3005.7). The key here is that fuel should be arranged or coordinated prior to activation.

Recommendation: AMC should contact DESC to arrange for fuel at Greenville. AMC could also check the availability of War Reserve Materiel fuel supplies to determine if there is any fuel near Greenville. If required, the CORE program could be used to ensure fuel delivery.

B. INDUSTRY RELATIONS

Relations with the CRAF participants could be greatly enhanced by improving responsiveness and communications. The bureaucracy and politics that are the quagmire of DoD workings appear intolerable to industry. If industry has a question, DoD should provide a prompt response. If that is not possible, DoD should provide interim status reports until the issue is resolved. If a meeting has to be postponed or rescheduled, it should be rescheduled as promptly as possible, and industry should be informed as to why the delay was necessary.

Recommendation: AMC should collect, monitor and act on airline industry concerns related to CRAF. AMC should provide quarterly situation reports to the airlines on open issues.

A CRAF airline representative stated that the basic contract format used by GSA has not changed since 1982 and that the format corresponds to archaic business practices. The airline official stated that the airlines had little input into the contract and that this was the status quo in doing business with the military. He said that the airlines could not, as an industry, make suggestions to the contract due to anti-trust issues. There have been many changes in government contracting over the last few years. The "revolution in business affairs" to include "best business practices" and "streamlining of government" needs to carry into this contract as well.

Recommendation: Representatives from GSA, Department of Transportation's (DOT) Office of Emergency Transportation (OET) and AMC should meet regularly and jointly reevaluate and update the CRAF contract. Input from the airlines should be solicited and included wherever feasible.

C. RECOMMENDATIONS FOR FUTURE RESEARCH

Thorough analysis has determined that many areas within the CRAF AE program require further investigation and study. Two issues in particular lend themselves to future research.

First, budget and funding priority and process for CRAF and in particular AE are a concern. The AE program will require additional funding to resolve some of the deficiencies. Further study of the funding process may disclose ways in which to obtain more funds from an additional source or increase the priority of the program in competing for limited funds.

Second, AESS design flexibility and the possibility of alternative airframes should be investigated. By the end of WW II, every military cargo/transport aircraft was equipped with cargo nets and attachment points that could support three to four litters high throughout most of the cabin. This system was highly flexible and fit any aircraft. However, the system did not facilitate medical care; nor was it the most comfortable for the patient. It is conceivable that a system could be designed that incorporates more flexibility, does not limit AE to one airframe, and provides more patient amenities.

THIS PAGE INTENTIONALLY LEFT BLANK

REFERENCES

A/A99S-3, Conversion Set, Aircraft Mission Installation/Instruction Manual, 15 November 1992.

Abscher, Pat. "Civil Reserve Air Fleet." Airlift Services Management Report, first quarter, fiscal year, 1988.

Alfano, Joseph P., Capt. and Capt. John C. O'Neill. "Wartime CONUS (Continental United States) Casualty Distribution System Using Dedicated CRAF Airlift." Thesis. Air Force Institute of Technology. March 1985.

Becker, James W. "European Civil Air: Can NATO Count on It?" Essay. National Defense University, 1989.

Bouchard, Capt. "Draft—Subject: AE Civil Reserve Air Fleet (CRAF) Conops." AMC/SGXB, Scott AFB IL, 6 December 1994.

Burschnick, Anthony J., Col. and Markwell A. Fletcher, LtCol. "History of Strategic Airlift: A Research Report", Air War College, Air University, Maxwell AFB, AL, April 1976.

Coffey, Roger K. and F. Ronald Frola. "The Civil Reserve Air Fleet: Trends and Selected Issues." Logistics Management Institute. May 1996.

Combs, Billy Cdr. "CRAF AE Background paper" e-mail. Wednesday, 6 October 1999.

Combs, Billy Cdr. "FW: CRAF AE Update" e-mail. Friday, 25 February 2000.

Combs, Billy Cdr. "FW: LOSS Kit Status" e-mail. Wednesday, 5 January 2000.

Combs, Billy Cdr. "LOSS Meeting Results" e-mail. Friday, 7 January 2000.

Combs, Billy Cdr. "RE: AE REQ" e-mail. Monday, 7 February 2000.

Combs, Billy Cdr. "Some ICMOP Information" e-mail. Thursday, 21 October 1999.

CRAF AESS CLS Program Management Review. Briefing slides. 28 September 1999.

Daly, John D., LtCol. "Air Transportation: Elements of a Changing Environment and What It Means to the Civil Reserve Air Fleet." Executive Research Project. Industrial College of the Armed Forces. April 1997.

Davis, Shelly L. "The Evolution of Aeromedical Airlift." *Airlift*. Vol. 8, No. 3, pp19-21. Fall 1986.

Delmoral, Maj. phoncon. Air Mobility Command HQ/DOF. 12 March 1999.
Deutschmann, Mary, Contracting Officer, US Department of the Air Force, Air Mobility Command. Solicitation No. F11626-99-R-0004. 12 April 1999.

DODD 3005.7. "Emergency Requirements, Allocations, Priorities, and Permits for DoD Use of Domestic Civil Transportation." ASD (MI&L). 30 May 1985.

DODD 5158.4. "United States Transportation Command." USD (A). 8 January 1993.

Donovan, Pamela S., Capt. "The Value of the Civil Reserve Air Fleet: How Much Could the DoD Spend on Incentives?" Thesis. Air Force Institute of Technology. September 1996.

Edwards, Robert Capt. AMC/SGX "RE: CTS." e-mail. Tuesday, 15 February 2000.

Edwards, Robert Capt. AMC/SGX "RE: CTS." e-mail. Wednesday, 16 February 2000.

Eichhorst, Thomas E., LtCol. "Military Airlift Turbulence, Evolution, and Promise for the Future." Research Report. Airpower Research Institute. May 1991.

Ewing, William B., Jr., Maj. "Casualty Evacuation and Distribution Using B-767 and C-9 Aircraft." Thesis. Air Force Institute of Technology. March 1986.

Fricano, Michael. LtCol. "The Evolution of Airlift Doctrine and Organization." Research Report. Air War College. Air University. April 1996.

Futrell, Robert F. "Development of Aeromedical Evacuation in the USAF, 1909-1960." USAF Historical Studies: No. 23. Vol. I and II. Air University. May 1960.

Gebman, Jean R., Lois J. Batchelder, Katherine M. Poehlmann. "Finding the Right Mix of Military and Civil Airlift, Issues and Implications." Vol. 1. Executive Summary. RAND, 1994.

Gebman, Jean R., Lois J. Batchelder, Katherine M. Poehlmann. "Finding the Right Mix of Military and Civil Airlift, Issues and Implications." Vol. 2. Analysis. RAND, 1994.

Gebman, Jean R., Lois J. Batchelder, Katherine M. Poehlmann. "Finding the Right Mix of Military and Civil Airlift, Issues and Implications." Vol. 3. Appendixes. RAND, 1994.

Glaze, John A., Maj. "The Mobilization Value Process: Effects on CRAF Participation." Graduate Research Project. Air Force Institute of Technology. June 1998.

Graper, Mark W. LtCol. "Civil Reserve Air Fleet Stage III: Viability and Implications." Research Paper. Naval War College. 19 June 1998.

Green, Mary E., Contracting Officer, U.S. Department of the Air Force, Air Mobility Command. Solicitation No. F11626-99-R-0001. 3 March 1999.

Grier, Peter. "The Comeback of CRAF." *Air Force Magazine*. July 1995. 50-53.

Halbert, LtCol. phoncon. Air Mobility Command/DOF. 8 March 1999.

Halbert, LtCol. phoncon. Air Mobility Command/DOF. 18 February 2000.

Halbert, Robert LtCol. "Re: CRAF AE" e-mail. Monday, 31 January 2000.

Harris, Jerry D. Maj. "Civilian Reserve Air Fleet: Should the USAF Use it Routinely?" Research Paper. Air Command and Staff College. March 1997.

House Committee on Armed Services, *Research and Development Subcommittee Hearings on the Posture of Military Airlift*, 94th Congress, 1st Session, 1975.

Introduction to the Civil Reserve Air Fleet Briefing Slides, AMC/DOF & DOY. CRAF Conference. 28 September 1999.

Lamontagne, Capt. phoncon. Air Mobility Command/DOF. 12 March 1999.

Lewis, Ira. "The Civil Reserve Air Fleet: Balancing Risks and Incentives." *Transportation Journal*. Vol. 38, No. 2, pp. 32-39. Winter 1998.

Marks, Robert Capt. "PLS Locations" email. Wednesday, 10 February 1999.

Medigovich, William M., Director, Office of Emergency Transportation, U.S. Department of Transportation Letter to CRAF Program Participants, January 1999, November, December 1998 and January 1999 CRAF Allocation.

Memorandum of Understanding Between the Department of Defense and the Department of Transportation Concerning the Contingency Response Program." 8 May 1982.

Menarchik, Douglas. *Powerlift--Getting to Desert Storm: Strategic Transportation and Strategy in the New World Order*. Westport, CT: Praeger Publishers, 1993.

Miller, Charles E., LtCol. "Airlift Doctrine." Airpower Research Institute. March 1988.

Office of Emergency Transportation. U.S. Department of Transportation. December 1999 CRAF Allocation.

Owen, Robert C. LtCol. "The Airlift System: A Primer." *Airpower Journal*. Vol 9, No. 3, pp 16-29. Fall 1995.

Palmby, William G., Maj. "Enhancement of the Civil Reserve Air Fleet...An Alternative for Bridging the Airlift Gap." thesis. School of Advanced Airpower Studies. March 1996.

Post, Charles A., Maj. "CRAF Incentives." Air Force Institute of Technology. November 1996.

Priddy, Ronald N. *A History of the Civil Reserve Air Fleet in Operations Desert Shield, Desert Storm, and Desert Sortie*. Cambridge, MA: Arthur D. Little Inc., 1993.

Priddy, Ron. phoncon. National Air Carriers Association. 28 January 2000.

Public Law 81-774. "Defense Production Act." 8 September 1950.

Robinson, Richard W. "Air Transport Systems: A Comparison of Alternatives and a Methodology for Contextual Analysis." Ph.D. dissertation, RAND Graduate School, 1993.

Ryan, Donald E., LtCol. "The Airship's Potential for Intertheater and Intratheater Airlift." thesis. Air University, June 1993.

"Shortfall in CRAF Aeromedical Evacuation Not Seen as Serious." *Aerospace Daily*. Vol. 184, No. 34, p. 268. 18 November 1997.

Simmons, John. "Liquid Oxygen." e-mail and phoncon. InAir. Friday, 12 March 1999.

Smith, Hubert G. LGen. Speech given at Military Traffic Management Command Annual Symposium in Louisville, KY. 26 March 1996.

Thomas, Richard E., Ph.D. "The Use of the Civil Reserve Air Fleet in Evacuation of Battlefield Casualties." Final Report. Texas A & M University for USAF School of Aerospace Medicine. July 1985.

Thomchick, Evelyn. "The 1991 Persian Gulf War: Short-term Impacts on Ocean and Air Transportation." *Transportation Journal*. Lock Haven. Winter 1993.

U.S. Congressional Budget Office. *Moving U.S. Forces: Options for Strategic Mobility*. February 1997.

U.S. Department of Defense, Inspector General. *Civil Reserve Air Fleet*. by Robert J. Lieberman, Assistant Inspector General for Auditing. Audit Report 92-068. April 1992.

U.S. Department of the Air Force, Headquarters Air Mobility Command. *1998 Air Mobility Master Plan*. Scott AFB, IL. October 1997.

U.S. Department of the Air Force, Summary of MVP Calculation Briefing Slides, 1999.

U.S. Department of the Air Force, USAF Fact Sheet, C-17 Globemaster III.

U.S. Department of the Air Force, USAF Fact Sheet, C-130 Hercules.

U.S. Department of the Air Force, USAF Fact Sheet 92-42.

U.S. General Accounting Office. *Military Airlift: Observations on the Civil Reserve Air Fleet Program*. by Mark E. Gebicke, Director, Military Operations and Capabilities Issues. Report to the Chairman and Ranking Minority Member, Subcommittee on Seapower, Committee on Armed Services, U.S. Senate. March 1996. (GAO-NSIAD-96-125)

User Manual Patient Loading System (PLS). UpRight, Inc., Selma, CA, P/N L5366-115.

Wales, William S. "Civil Reserve Air Fleet Enhancement Program: A Study of Its Viability in Today's Environment." thesis, Naval Postgraduate School, March 1998.

Whitehurst, Clinton H. "The Defense Transportation System Competitor or Complement to the Private Sector?" American Enterprise Institute for Public Policy Research. Washington, D.C. October 1976.

Wilhite, Donald R., Maj. "USAF Civil Reserve Air Fleet Aeromedical Evacuation Airlift Capability." Graduate Research Paper. Air Force Institute of Technology. May 1996.

THIS PAGE INTENTIONALLY LEFT BLANK

INITIAL DISTRIBUTION LIST

1. Defense Technical Information Center 2
8725 John J. Kingman Rd., Suite 0944
Fort Belvoir, Virginia 22060-6218
2. Dudley Knox Library 2
Naval Postgraduate School
411 Dyer Road
Monterey, California 93943-5101
3. Donald R. Eaton RADM (Ret), Code SM/Et..... 1
Naval Postgraduate School
Monterey, California 93943-5103
4. Dr. Ira A. Lewis, Code SM/Le..... 1
Naval Postgraduate School
Monterey, California 93943-5103
5. Dr. Lee Edwards, Code SM/Ed..... 1
Naval Postgraduate School
Monterey, California 93943-5103
6. CINCLANTFLT (Code N413T)..... 1
Attn: LCDR Dawn D. Richardson
1562 Mitscher Avenue Suite 250
Norfolk, Virginia 23551-2487
7. NAVTRANS..... 1
Attn: CAPT Mark T. Brown
1667 Piersey Street
Norfolk, Virginia 23511-2806
8. USTRANSCOM/TCJ5-AA 1
Attn: Michael L. Spehar
508 Scott Drive
Scott Air Force Base, Illinois 62225-5357
9. USTRANSCOM/TCJ5-AA 1
Attn: CDR Billy Combs
508 Scott Drive
Scott Air Force Base, Illinois 62225-5357

- 10. USTRANSCOM/TCJ5-SC 1
 Attn: LCDR John G. Meier, III
 508 Scott Drive
 Scott Air Force Base, Illinois 62225-5357

- 11. AMC/DOF 1
 Attn: COL Robert Halbert
 402 Scott Drive Unit 3A1
 Scott Air Force Base, Illinois 62225-5302

- 12. AMC/SGX 1
 Attn: CAPT Robert Edwards
 203 West Losey Street Suite 1180
 Scott Air Force Base, Illinois 62225-5219

- 13. DOT OET 1
 Attn: William Medigovich
 Office of Emergency Transportation
 Research and Special Programs Administration
 400 7th St SW Room 8404
 Washington, D.C. 20590

- 14. GSA 1
 Attn: William Rivers
 Director, Travel Policy Division
 General Services Administration
 1800 F St, NW
 Washington, D.C. 20405

- 15. DFAS 1
 Attn: CAPT Kevin Carman
 Defense Finance and Accounting Service
 4181 Ruffin Road
 San Diego, CA 92128

- 16. NACA 1
 Attn: Mr. Ronald Priddy
 National Air Carriers Association
 910 17th St NW
 Washington, D.C. 20006

- 17. Director Transportation and Movements (DTM) 1
 Attn: LCOL Keith Harrison
 National Defence Headquarters
 Ottawa, Ontario K1A OK2
 CANADA