

AD _____

AWARD NUMBER DAMD17-97-1-7284

TITLE: The Molecular Basis of the Response to Radiation

PRINCIPAL INVESTIGATOR: Sharon E. Plon, M.D., Ph.D.

CONTRACTING ORGANIZATION: Baylor College of Medicine
Houston, Texas 77030-3498

REPORT DATE: July 1999

TYPE OF REPORT: Annual

PREPARED FOR: U.S. Army Medical Research and Materiel Command
Fort Detrick, Maryland 21702-5012

DISTRIBUTION STATEMENT: Approved for Public Release;
Distribution Unlimited

The views, opinions and/or findings contained in this report are those of the author(s) and should not be construed as an official Department of the Army position, policy or decision unless so designated by other documentation.

20000424 199

REPORT DOCUMENTATION PAGE

Form Approved
OMB No. 0704-0188

Public reporting burden for this collection of information is estimated to average 1 hour per response, including the time for reviewing instructions, searching existing data sources, gathering and maintaining the data needed, and completing and reviewing the collection of information. Send comments regarding this burden estimate or any other aspect of this collection of information, including suggestions for reducing this burden, to Washington Headquarters Services, Directorate for Information Operations and Reports, 1215 Jefferson Davis Highway, Suite 1204, Arlington, VA 22202-4302, and to the Office of Management and Budget, Paperwork Reduction Project (0704-0188), Washington, DC 20503.

1. AGENCY USE ONLY <i>(Leave blank)</i>	2. REPORT DATE July 1999	3. REPORT TYPE AND DATES COVERED Annual (1 Jul 98 - 30 Jun 99)	
4. TITLE AND SUBTITLE The Molecular Basis of the Response to Radiation		5. FUNDING NUMBERS DAMD17-97-1-7284	
6. AUTHOR(S) Sharon E. Plon, M.D., Ph.D.			
7. PERFORMING ORGANIZATION NAME(S) AND ADDRESS(ES) Baylor College of Medicine Houston, Texas 77030-3498 E*Mail: splon@bcm.tmc.edu		8. PERFORMING ORGANIZATION REPORT NUMBER	
9. SPONSORING / MONITORING AGENCY NAME(S) AND ADDRESS(ES) U.S. Army Medical Research and Materiel Command Fort Detrick, Maryland 21702-5012		10. SPONSORING / MONITORING AGENCY REPORT NUMBER	
11. SUPPLEMENTARY NOTES			
12a. DISTRIBUTION / AVAILABILITY STATEMENT Approved for public release; distribution unlimited		12b. DISTRIBUTION CODE	
13. ABSTRACT <i>(Maximum 200 words)</i> <p>This is the second year of this four year CDA Award. The most challenging aspect of this project is the isolation of novel cDNAs encoding human homologs of yeast DNA damage response genes. To date complementation of the yeast mutant <i>rad9</i> have not yielded human cDNAs with significant homology. Thus, over the last year we have made a major effort to isolate cDNAs by degenerate PCR strategies which is still underway. In addition, the use of specific two hybrid screens using known human DNA damage response/cell cycle genes has resulted in the isolation of human homologs of <i>RAD18</i> and <i>RAD21</i>. The subsequent objectives are focused on determination of whether cDNAs isolated in genetic screens are altered in expression or structure in breast cancers. The reagents including RNA, DNA and protein from human breast cancer cell lines grown under identical culture conditions were produced during the first year of this award. This set of reagents has been used and demonstrated increased expression of the <i>RAD21</i> RNA in some breast cancer cell lines. This prompted the development of a Rad21 antibody that has been completed and will be used for analysis of protein expression in these lines and murine models of mammary tumorigenesis in subsequent years of the grant.</p>			
14. SUBJECT TERMS Breast Cancer		15. NUMBER OF PAGES 21	
		16. PRICE CODE	
17. SECURITY CLASSIFICATION OF REPORT Unclassified	18. SECURITY CLASSIFICATION OF THIS PAGE Unclassified	19. SECURITY CLASSIFICATION OF ABSTRACT Unclassified	20. LIMITATION OF ABSTRACT Unlimited

FOREWORD

Opinions, interpretations, conclusions and recommendations are those of the author and are not necessarily endorsed by the U.S. Army.

___ Where copyrighted material is quoted, permission has been obtained to use such material.

___ Where material from documents designated for limited distribution is quoted, permission has been obtained to use the material.

___ Citations of commercial organizations and trade names in this report do not constitute an official Department of Army endorsement or approval of the products or services of these organizations.

In conducting research using animals, the investigator(s) adhered to the "Guide for the Care and Use of Laboratory Animals," prepared by the Committee on Care and use of Laboratory Animals of the Institute of Laboratory Resources, national Research Council (NIH Publication No. 86-23, Revised 1985).

For the protection of human subjects, the investigator(s) adhered to policies of applicable Federal Law 45 CFR 46.

In conducting research utilizing recombinant DNA technology, the investigator(s) adhered to current guidelines promulgated by the National Institutes of Health.

In the conduct of research utilizing recombinant DNA, the investigator(s) adhered to the NIH Guidelines for Research Involving Recombinant DNA Molecules.

___ In the conduct of research involving hazardous organisms, the investigator(s) adhered to the CDC-NIH Guide for Biosafety in Microbiological and Biomedical Laboratories.

PI - Signature

7/28/99
Date

Molecular Basis of the Response to Radiation Therapy

Table of Contents	Page number
Front Cover	1
Standard Form 298	2
Foreword	3
Table of Contents	4
Introduction	5
Body	5
Conclusions	10

Introduction

The goal of this project is to further define at a molecular level the human gene products required for the normal G2 checkpoint response after DNA damage. The checkpoint response is a fundamental mechanism by which cells control their cell division cycle after experiencing DNA damage from radiation. This response results in an arrest in the G2 phase of the cycle until damage is repaired. This checkpoint response is conserved among eukaryotes including the budding yeast *Saccharomyces cerevisiae*. In our application, we proposed to exploit this conservation to isolate human checkpoint genes by large scale complementation screens and homology searches isolating novel human cDNAs which can complement yeast G2 checkpoint mutant strains. Subsequent Technical Objectives are directed towards understanding the structure and expression of these genes in both normal and malignant mammary cells including human cell lines and murine models of mammary tumorigenesis. We also planned to perform functional assays of these cDNAs in checkpoint deficient cell lines including the MCF-7 human breast cancer cell line. In this report we detail progress in the second year of this award towards all three objectives. This grant is co-funded with a companion IDEA Award (having just completed the first year) for the PI, Dr. Sharon Plon (grant #DAMD17-98-1-8281).

A. Progress toward completing the proposed Technical Objectives.

Materials and Methods:

Complementation Assay: Exponential cultures of a *cdc9-8, rad9* strain grown in YM-1 media were transformed with purified cDNA library DNA using a modified Li-Acetate transformation protocol of Schiestl, and Giets and yeast total RNA and denatured salmon sperm DNA as carrier to achieve a transformation efficiency of 300,000 colonies per microgram plasmid DNA. After transformation the plates were incubated at 23°C overnight. In the morning plates were transferred to 30°C and incubated for 5 days. Colonies growing at this point are isolated and restreaked on leucine deficient media at 30°C for further analysis.

PCR Conditions and Analysis: Degenerate primers are designed after doing alignment of yeast checkpoint genes using the ClustalW program on the BCM Human Genome Project Search Launcher. PCR conditions are optimized for both Mg⁺⁺ concentration and annealing temperature with control templates (either cloned *S. cerevisiae* genes or genomic samples from *S. cerevisiae* and *S. pombe*). After PCR amplification of human cDNA libraries as described below, PCR products are analyzed on 4% NuSieve agarose gels to allow size discrimination of small PCR products. cDNA from human sources including normal mammary gland and mammary carcinoma was obtained from Clontech. PCR products of appropriate sizes are subcloned using either the Invitrogen TA or Topo cloning kits. Inserts are confirmed by miniprep DNA preparations and restriction digest. Representative clones for each size are then sequenced using dideoxy automated sequencing methodologies (Licor or ABI automated sequencers).

Two-hybrid Reagents: Reagents used in the two-hybrid screening include the Gal4-activation domain (AD) library, the Gal4-DNA binding (DB) vector (pPC97), the yeast host strain MV103 (Mat a, *leu2, trp1, his3, Gal1:HIS3, Gal1:LacZ, Spal:URA3*), and 5 constructs in MV103 for use as reference controls during screening (22, 23). Control plasmids include 1) DB-pPC97+AD-pPC86, 2) DB-pRb+AD-E2F1, 3) DB-Fos+AD-Jun, 4) Gal4+AD, 5) DB-dDP-1+AD-dE2F.

Activation domain-cDNA library: A human T-lymphocyte cDNA fusion library in the activation domain vector pPC86 (Trp+) was kindly provided by J. La Baer (MGH Cancer Center). The cDNAs were cloned into the *EcoRI* (5') and *SpeI* (3') sites. This library has approximately 2×10^6 clones and the average insert size is 1kb. This library was amplified once by electroporation using electrocompetent *E. coli*, JS4 cells (BioRad, Hercules, CA) followed by replica plating onto LB+Ampicillin plates. The DNA was prepared using a Plasmid Maxi kit from Qiagen.

Selection of interacting genes: The bait (Leu+) and the library plasmid (Trp+) were sequentially transformed into the yeast host strain MV103. The transformants containing the bait and library plasmids were selected on media lacking leucine and tryptophan. Three separate pools of library DNA were used to transform the MV103+pPC97-*CDC34* or MV103+pPC97-*RAD6* cells and 500,000 transformants from each pool were obtained. The two-hybrid screen was performed by first selecting for growth of bait-library co-transformants on Sc-His-Leu-Trp+25mM 3AT. Subsequently additional reporter genes, *URA3* and *LacZ*, were selected for in the 3AT positive clones. The expression of the *URA3* gene was both selected for on media lacking uracil as well as counterselected against on media containing uracil and 0.1% 5-fluoroorotic acid (5FOA). Induction of the *LacZ* gene was assayed qualitatively in the presence of X-Gal for blue colonies. The phenotypes were then scored. Clones positive for all the reporters were PCR cloned into a pPCRII vector using TA-cloning kit from Invitrogen (Torry Pines, CA). Both strands of the DNA were then sequenced using a LI-COR automated sequencer.

RESULTS

Technical Objective 1 - Isolation of additional human G2 checkpoint genes.

- a. **Complementation Assay:** During the first year of this award a large-scale complementation screen of a *rad9,cdc9-8* strain was performed as described. Fifteen human cDNAs were isolated as part of that screen. During this year further characterization of those fifteen cDNAs was performed. A test for plasmid dependence including isolating the human cDNA containing plasmid from the yeast transformant was performed with subsequent re-transformation of the *rad9,cdc9-8* strain. This analysis revealed that fourteen of the clones did not confer plasmid dependence, eg, were due to reverting mutations in the strain. For the fifteenth strain, the plasmid did confer partial rescue of the checkpoint defect. The cDNA inserts were subcloned into sequencing vectors. Sequence analysis of this clone revealed a partial cDNA encoding a ribosomal protein that did not reveal any homology to *RAD9* protein. Thus, we were not able to identify an active cDNA through this complementation assay.
- b. A major emphasis during this year of the grant was the use of homologous regions between evolutionarily distant species (*S. cerevisiae* and *S. pombe*) to develop degenerate PCR based primers. For example, a fission yeast homolog of *RAD9* named *rhp9* was published. Alignment of those sequences reveals areas of homology that may suggest conserved regions of the protein. One such area is in the carboxy terminus consistent with the known BRCT domain. In addition there are more discreet areas of homology in the carboxy terminus that may reflect *RAD9/rhp9* specific conserved domains. We have made a

major effort to develop a series of degenerate PCR primers to this regions. Overall over 200 PCR reaction sets (varying primers and templates) have been performed. These primers are optimized on test templates including the *RAD9* gene itself as well as yeast genomic DNA. We have now begun amplification from human cDNA sources including lymphocyte cDNA libraries. We have also done amplification from Lamprey DNA which represents a species that is approximately intermediate in evolution between humans and yeast. The PCR products are then subcloned and sequenced as described in the method section. Table 1 illustrates the number of PCR primers developed, the number of fragments subcloned and sequenced. To date the sequences obtained do not demonstrate additional regions of homology to the *S. cerevisiae RAD9* gene. An analogous approach has been taken with *DUNI* and to date subcloned PCR products from human lymphocyte cDNA libraries has not yielded homologous sequences.

Table 1 – Summary of Degenerate PCR approach to cloning of Human *RAD9* and *DUNI*

Gene	Primer Sets	Templates	Clones Sequenced
<i>RAD9/rhp9</i>	4	Human T cell library (3 independent pools) Mouse Embryonic library Lamprey Genomic DNA	19
<i>DUNI</i>	4	Human T cell library (3 independent pools) Lamprey Genomic DNA	38

Our analysis of why we have not obtained sequences lead to three potential possibilities (1) such homologous sequences do not exist in the human genome, (2) the cDNA libraries chosen do not represent tissue where the gene is expressed and (3) the general bias towards shorter cDNAs in library constructs may discriminate against the generally long checkpoint cDNAs. Given that we find the first possibility unlikely based on the overall conservation of the pathway and the conservation of *rad9* and *rhp9*, we are addressing the second two concerns. We have obtained human cDNA from multiple sources including normal mammary gland, an explant of a human breast carcinoma, normal ovarian tissue and bone marrow in order to maximize the chance of finding a tissue specific gene. The use of cDNA will avoid bacterial contamination seen in library samples and provide detection of sequences from long cDNAs. We are currently using two sets of degenerate primers for the *RAD9* homologs on these sets of cDNAs. PCR products of the appropriate length have been obtained for one set of *RAD9* degenerate primers from a mammary carcinoma cDNA source. This fragment has been subcloned and sequence analysis is underway. The same methodology will be used for the other sets of degenerate primers. If additional regions of homology to *RAD9* are identified then this sequence will be used as a probe to identify longer cDNAs. This

same approach is now being taken with three sets of degenerate primers for homologous regions of *DUN1* and the human cDNA samples.

A third approach is searching of human cDNA and genomic sequence databases. We have recently identified a short human EST cDNA which is a partial clone with a 200 amino acid open reading frame with homology to *S. cerevisiae RAD9*. We are using this cDNA to identify other anonymous cDNAs from this locus, will build a computer-based contig of the sequence as well as isolate longer cDNAs from this locus. Our goal is to determine if this partial cDNA represents a portion of a longer cDNA with significant homology to *RAD9*.

- c. Several other genetic screens including two-hybrid screens in yeast for human cDNAs in the DNA damage checkpoint and repair response have been accomplished. As part of those screens cDNAs encoding the human homolog of *S. pombe RAD21* and *S. cerevisiae RAD18* were isolated. The *RAD21* sequence has been previously reported in the literature although the human gene has not been thoroughly characterized previously (see below). The *RAD18* sequence has not been reported. We are currently screening additional cDNA libraries to obtain a full length clone of this gene for subsequent analysis in aims 2 and 3..

Technical Objective 2A – Checkpoint gene structure and expression in human breast cancer cell lines.

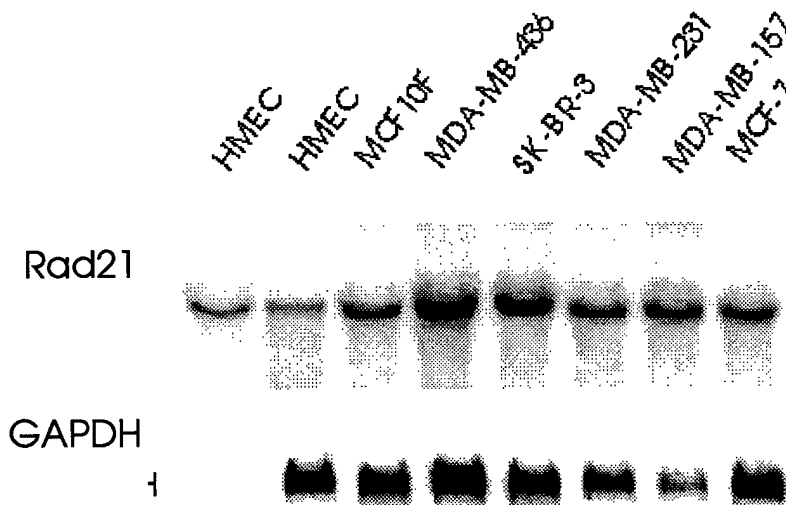

Figure. Northern blot analysis of the hCDC34 interacting cDNAs in a panel of breast-cancer derived cell lines. Expression of the house keeping GAPDH gene is shown to compare loading. HMEC represent normal breast epithelial cells.

As described in the original grant application and begun during year one of the CDA award, we obtained normal human mammary epithelial cells (HMEC) from Clonetics

and a panel of eight human mammary derived cell lines, MCF10A, MCF7, MDA-MB-157, MDA-MD-231, MDA-MB-136, BT-20, HBL100 and SKBR-3. These were all grown in culture under controlled conditions. All the cell lines were grown in the same DFCI media to minimize artifacts due to culture technique including both the immortal but not transformed MCF10 and the transformed lines. One exception is the HMEC cultures which require a separate proprietary media. In parallel RNA, DNA and protein lysates were derived from these cultures. The isolation of RNA was repeated on a fresh set of cultures in order to be able to replicate any findings on the first set. Analysis of expression of *RAD21* reveals increased expression at the RNA level in breast cancer cell lines, specifically MDA-MB-436 and SK-BR-3 in comparison to the HMEC controls.

In order to pursue that finding with regard to human *RAD21* RNA we created reagents to perform detailed analysis of the Rad21 protein. We have identified an antigenic peptide in the carboxy terminus based on homology with the antibody previously raised against the sea urchin protein. This peptide was synthesized and used in production of an anti-human Rad21 polyclonal antibody. ELISA analysis of this serum shows high reactivity. In addition Western blot analysis demonstrates that the antisera recognizes a protein of the appropriate molecular weight in lysates from human cell lines with very high affinity. In addition in order to be able to perform analysis of immunoprecipitated protein (using a polyclonal IP, monoclonal Western method) we have also begun development of an anti-human Rad21 monoclonal antibody. A fusion construct with human Rad21 and GST tag was constructed and used for the production of the antigen. Production of the monoclonal antibody is underway.

Technical Objective 3 - Determination of Changes in Response to Radiation of a Human Breast Cancer Cell Line upon Expression of Human Checkpoint Genes.

The first portion of this aim is based on examining whether the human cDNAs previously identified or identified in Aim 1 will suppress the G2 checkpoint defect in the human MCF-7 breast cancer cell line. We have begun this analysis for human Rad21 using an epitope tagged version. With development of the antibodies as described in aim 2 this analysis will be further facilitated. Analysis of ectopically expressed Rad21 by Western blot does not show significant differences in the level of the protein after exposure to UV and gamma irradiation. Alternative gel techniques will need to be used in order to determine if there is a change in phosphorylation or nuclear localization after DNA damage.

Key Research Accomplishments:

- Analysis of human cDNAs obtained by screening of a human cDNA library for complementation of *rad9* mutant strain completed.
- Extensive degenerate PCR cloning to obtain human homologs of *RAD9* and *DUN1* initiated.
- Cloning of cDNAs encoding the human homolog of *RAD21* and *RAD18*.
- Polyclonal antibody to human Rad21 protein produced.

Reportable Outcomes:

- Work on *CHES1* was presented as an invited talk at the International Meeting on Fork head/ Winged Helix Proteins at Scripps Research Institute, La Jolla CA, November 1999.
- Review Article on BRCA1/2 Mutation testing was published and support acknowledged. Plon, S.E. (1998) Screening and Clinical Implications for BRCA1 and BRCA2 Mutation Carriers. *J Mammary Gland Biology and Neoplasia*, 3(4), 377-387.
- Polyclonal antibody to human Rad21 protein produced.

C. Conclusions

In the second year of this four year IDEA Award we have continued to make progress towards all three Technical Objectives. The most challenging aspect of this project is the isolation of novel cDNAs encoding human homologs of yeast DNA damage response genes. To date complementation of the yeast mutant *rad9* have not yielded human cDNAs with significant homology. Thus, over the last year we have made a major effort to isolate cDNAs by degenerate PCR strategies which is still underway. Finally, we do routine searches of human cDNA and genomic databases for newly sequenced genes which demonstrate homology (we are currently following up on a new EST with homology to *RAD9*). We will continue over the next year to focus on these latter two strategies for both human homologs of *RAD9* and *DUN1*. In addition, the use of specific two hybrid screens using known human DNA damage response/cell cycle genes has resulted in the isolation of human homologs of *RAD18* and *RAD21*.

The subsequent objectives are focused on determination of whether cDNAs isolated in genetic screens are altered in expression or structure in breast cancers. The reagents including RNA, DNA and protein from human breast cancer cell lines grown under identical culture conditions were produced during the first year of the CDA award. This set of reagents has been used and demonstrated increased expression of the *RAD21* RNA. This prompted the development of a Rad21 antibody which has been completed and will used for analysis of protein expression in these lines and murine models of mammary tumorigenesis. Similarly, in Objective Three this antibody will be used to further probe alteration in Rad21 expression or modification after DNA damage. In addition to analysis of genes isolated by this investigator a number of other groups have published cDNA sequences for human homologs of checkpoint genes including Rad53. These genes will be incorporated into our analysis of regulation in normal and malignant mammary cells in the next year of this award.

Screening and Clinical Implications for *BRCA1* and *BRCA2* Mutation Carriers

Sharon E. Plon^{1,2}

In this article, we review the history of testing for mutations in breast cancer susceptibility genes and discuss the current state of testing for mutations in *BRCA1* and *BRCA2* in different clinical settings including at-risk individuals and cancer patients. The risk of breast cancer, other associated malignancies and prognosis in carriers of these mutations are reviewed. A final section includes discussion of current recommendations for surveillance and the need for further research to identify environmental and genetic factors which modify the risk of developing cancer in mutation carriers.

KEY WORDS: *BRCA1*; *BRCA2*; breast cancer; ovarian cancer; cancer susceptibility genes; mutation detection.

INTRODUCTION

The localization (1,2) and eventual cloning (3,4) of specific breast cancer susceptibility genes has led to enormous interest in the clinical application of this data from both the medical and lay communities. In this article we summarize the early and current uses of predictive testing for mutations in the *BRCA1* and *BRCA2* cancer susceptibility genes. We also review the cancer risks that can be attributed to these mutations and then describe some of the pressing research questions with regard to molecular testing, surveillance and prevention of cancer in these high-risk individuals.

The subject of mutational analysis for mutations in *BRCA1* and *BRCA2* includes a substantial literature with regard to the potential legal and ethical problems individuals facing testing must consider. This topic is beyond the scope of this review and has been recently reviewed by a number of authors (5,6). In addition, a

number of professional societies and advocacy groups have developed statements with regard to this topic (7,8). A review of some of the conflicts between these different policy statements has recently been published (9).

INITIAL SCREENING BY LINKAGE ANALYSIS

The localization of an early onset breast cancer gene to chromosome 17q21 was the initiating event in the use of DNA testing to clarify an individual's risk of developing breast cancer (1). A number of epidemiological studies had previously demonstrated that a family history of breast cancer was a major predisposing factor for breast cancer (10). Programs were developed that evaluated women at high risk of developing breast cancer based on significant family histories, adverse reproductive risk factors, adverse pathology on breast biopsy and multiple breast masses (11). However, decisions about risk of cancer were not based on a specific molecular diagnosis, and the models used to predict risk are not accurate in families segregating a dominant breast cancer susceptibility gene (11).

¹ Departments of Pediatrics, Molecular and Human Genetics, Texas Children's Cancer Center, Baylor College of Medicine, Houston, Texas.

² To whom correspondence should be addressed at Texas Children's Hospital MC3-3320, 6621 Fannin Street, Houston, Texas 77030. e-mail: splon@bcm.tmc.edu

For many disorders inherited as a Mendelian trait, gene localization was sufficient to begin fairly robust molecular testing based on genetic linkage analysis. For example, localization of the gene responsible for Huntington's disease to chromosome 4 led to the clinical use of genetic linkage analysis for almost 13 years before the precise gene and specific mutations were identified (12). Cancer genetic syndromes, where linkage analysis was or is commonly used, include von Hippel Lindau syndrome and familial adenomatous polyposis. Analysis of risk by linkage study is based on following highly polymorphic markers that map close to the disease causing mutation in an affected family. The use of polymorphism allows prediction of risk by ascertaining whether the at risk individual has inherited the haplotype associated with the disease state in the family. The power of linkage analysis is the ability to make fairly precise predictions without knowing the identity of the gene responsible for the condition or the specific mutation found in the family. Clinically, however, the most important weakness of linkage analysis is the prediction error based on the possibility of recombination between the markers and the disease allele. This latter problem is now significantly diminished by the large number of polymorphic markers available for linkage analysis.

Despite the well developed programs in linkage analysis in other genetic syndromes, the utility of linkage analysis for breast cancer carrier status has been quite limited for at least three important reasons. (i) It became obvious quite early that genetic heterogeneity existed (1) meaning that one could not be certain, for most families, that a cancer susceptibility gene on 17q21 segregated in the family (13). Therefore linkage analysis could only be performed in families large enough to prove linkage to 17q21. (ii) The high incidence of cancer mortality in affected individuals limited the number of family members for whom one could obtain DNA samples for linkage analysis. (iii) The high frequency of phenocopies of breast cancer in any given pedigree greatly increased the uncertainty of the linkage assignment. The concept of phenocopy relates to the finding that, in a family, a woman with breast cancer may have developed that cancer spontaneously and is therefore incorrectly assigned as affected in the linkage analysis (14).

For these reasons, the use of linkage analysis has been limited to large families who were extensively studied in a research setting during the search for the *BRCA1* and *BRCA2* genes. In this limited setting, predictions of carrier status were made for families where

the precise mutation has not been identified (15). Although these cases were limited, they received a great deal of attention at national scientific meetings and in the media. This early use of predictive testing in these families initiated much of the discussion with regard to the ethical, legal and social implications of cancer susceptibility testing before it was clinically applicable to the population outside of this limited setting.

DEVELOPMENT OF DIRECT MUTATIONAL ANALYSIS

The cloning of the *BRCA1* and *BRCA2* genes catalyzed the development of large scale mutational testing because of the large number of at risk individuals (compared to other genetic syndromes) and the complexity of the mutational spectrum. Early analysis of the mutation spectrum in *BRCA1* (16), and subsequently *BRCA2* (4), lead to the findings that the mutations were "private" in the vast majority of families and that there was not an overwhelming prevalence of one type of mutation. Approximately 85% of mutations in *BRCA1* result in a truncated protein (16). Thus, protein truncation testing has been proposed and is in use in some commercial laboratories to define the majority of mutations. The projected interest and potential market in clinical testing for *BRCA1* and *BRCA2* mutations has also resulted in the development of large-scale sequencing strategies that analyze both the entire open reading frame and intron/exon junctions for the *BRCA1* and *BRCA2* genes resulting in analysis of nearly twenty thousand basepairs of DNA.

Testing paradigms clinically in use include direct full-scale sequencing of *BRCA1* and *BRCA2*, or a staged approach. The staged approach can include analysis of one gene and then the other, or begin with a search for common mutations, then truncating mutations and subsequent sequencing. The selection of the gene to be searched first is based on clinical history. A recent analysis of 237 highly affected families demonstrated that 76% of families with male breast cancer had mutations in *BRCA2* and that 81% of families with both breast and ovarian cancer had mutations in *BRCA1* (17). Some laboratories use mutation scanning methods as opposed to sequencing to limit the cost. To date results similar to those obtained from full-length sequencing have been reported (17). However, the costs of either the scanning or full sequencing methods for both genes is substantial (\$2400 for full

sequencing) and is a major impediment to the clinical utility of mutational analysis. The high cost and relatively large pool of potential patients has led to exploration of a microarray or chip based technology for mutation detection in the *BRCA1* and *BRCA2* genes. But to date none of these methods are being offered on a clinical basis.

The initial experiences with full-scale scanning and sequencing analysis in clinical settings have been reported. *BRCA1* mutations were found in 16% of families of 194 affected individuals ascertained to have a positive family history who sought evaluations in a high-risk program (18). Shattuck-Eiden, *et al.*, analyzed the *BRCA1* gene by full sequencing in 918 individuals seeking mutational analysis in clinical centers (19). Overall mutations were found in only 13% of patients. Analysis of the individuals studied by both groups led to prediction of characteristics of patients in whom mutations are more or less likely to be identified. Not surprisingly, women with breast or ovarian cancer who had significant family histories of cancer were the most likely to be mutation carriers. For *BRCA1* analysis individuals with a personal or family history of ovarian cancer were more likely to test positive than those with a history of breast cancer. For breast cancer, a younger age of onset of the cancer in the proband or relative was associated with a greater likelihood of finding a mutation. The finding of *BRCA1* mutations in only 13–16% of subjects contrasts with the results of the Breast Cancer Linkage Consortium (BCLC)³ (17) where mutations were found in *BRCA1* in 64 of 180 (35%) families who met the criteria for the consortium. This difference is due to the large number of individuals seeking evaluation in the former studies who are from “high risk” families with substantially fewer cases of early onset breast cancer and ovarian cancer than required by the Consortium. Mutational analysis has also been performed on cohorts of early-onset breast cancer patients independent of family history. In studies of non-Ashkenazi American breast cancer patients under age 40, specific *BRCA1* mutations are found in approximately 7% (20). Addition of *BRCA2* analysis may only increase this estimate to approximately 10% of cancer patients under age 40 who have a detectable mutation (21).

CLINICAL PROGRAMS FOR RISK ASSESSMENT AND MOLECULAR DIAGNOSTICS

The high frequency of breast cancer (both hereditary and non-hereditary in origin) has led to the development of a number of different clinical screening programs for risk assessment and molecular diagnostics. The majority of these programs are part of ongoing research studies designed to determine the impact of testing for cancer susceptibility. The need for thorough counseling before and after testing as well as a detailed informed consent process must be emphasized.

At risk individuals from high-risk families. Analysis of molecular diagnostic testing strategies have been most intensive for women with a significant family history of breast cancer who have not yet developed cancer themselves (Fig. 1). Beginning with at risk members of families used in the original studies to identify linkage, investigations were initiated to determine a number of parameters including: interest in testing, likelihood of finding an informative mutation, psychological impact of testing, impact of testing on medical surveillance, and interest in or use of prophylactic surgery.

In initial studies, at-risk women who were offered the theoretical possibility of testing demonstrated very high interest (22). In subsequent studies where testing was actually offered variable interest was observed. The variability is partially due to the way in which

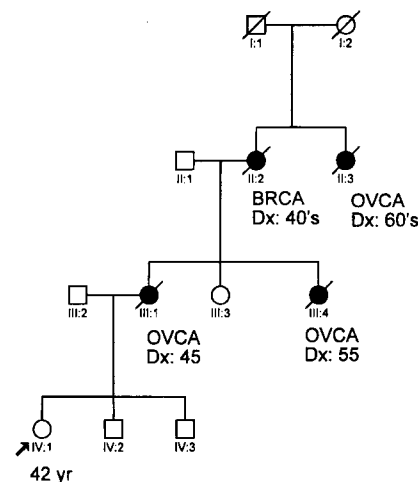

Fig. 1. Example of a pedigree from a 42-year-old woman (arrow-IV:1) seeking evaluation for *BRCA1* and *BRCA2* mutations in a Cancer Genetics clinic. Type of cancer and age of diagnosis (Dx) if known or whether pre- or post-menopausal are indicated. BRCA = breast cancer; OVCA = ovarian cancer; UL = unilateral.

³ Abbreviations: Breast Cancer Linkage Consortium (BCLC).

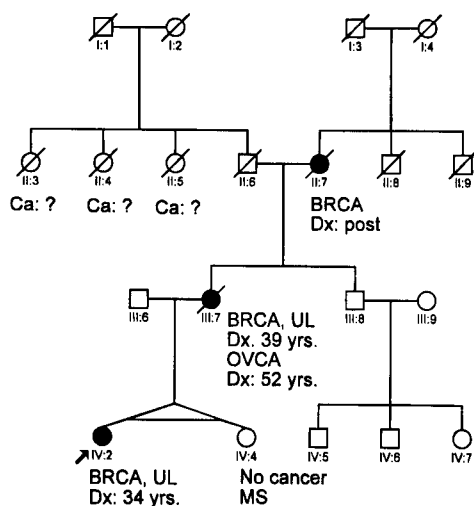

Fig. 2. Example of a pedigree with clinical discordance between monozygotic twins. Individual IV:2 was found to carry a truncating mutation in the *BRCA1* gene and developed breast cancer at age 34. At age 44, individual IV:4 remains cancer-free. MS = multiple sclerosis. Other abbreviations same as Fig. 1.

subjects elected to participate in the study. For example, in one study of at-risk relatives who were offered an educational session on genetic testing approximately 50% of the relatives elected to attend; but of those who did attend nearly 90% elected to be tested (23). Therefore, those motivated enough to attend educational sessions were highly motivated to pursue testing despite education about potential risks. Over the last two years a number of investigators have begun to accrue data on the psychological impact on women entered into testing protocols (24). Although beyond the scope of this article, these studies suggest the importance of both pre- and post-test counseling of individuals undergoing testing. They also suggest that certain populations of women may be more likely to undergo psychological distress after testing (25). A recent study of psychological effects of testing in high risk families found the greatest decrease in psychological functioning over time among those family members who had high pre-test levels of stress but declined to participate in testing (26). Overall, studies are needed to determine the impact of testing in participants who better reflect the general population and who do not come from families that have previously participated in research studies.

A major problem in molecular testing for *BRCA1* and *BRCA2* mutations for at risk individuals is the necessity that affected relatives be tested first to identify the disease causing mutation in the family. As discussed above, the presence of private mutations

in most populations, and a variable ability to detect mutations based on the degree of cancer in the family, make it crucial that a DNA sample from a closely related affected family member (preferably with either early onset breast cancer or ovarian cancer) be tested first. If a mutation is not found in the affected relative, then no further testing of at risk individuals is warranted, and their risk remains that derived from their personal family history. This type of negative result in affected relatives can be misinterpreted as a true negative result. For example, misunderstanding of this type of negative test was found in almost 30% of physicians ordering predictive testing for colon cancer (27).

If a disease causing mutation is identified in the affected relative, then at-risk relatives can be tested for the presence of that specific mutation. For the family shown in Fig. 1, the daughter (arrow) has a 50% a priori risk of having inherited a disease allele from her mother. Her risk would then be increased to 100% or decreased to 0%, depending on the subsequent mutational analysis of her DNA. However, testing an affected relative first is quite problematic in the clinic for a number of reasons. (i) In a number of cases (Fig. 1), the affected relatives in the family have all died, and full-gene analysis from archival materials has been problematic. (ii) The living affected relative tested may be a phenocopy (especially if she has post-menopausal breast cancer) and therefore may not carry the disease causing mutation in the family. (iii) The result of full-sequencing analysis may be the identification of a variant that is not clearly a deleterious mutation (19). In most cases a missense mutation resulting in an amino acid change is only considered to be a true cancer predisposing mutation if it has been reported in other families. In large families, subsequent analysis to determine whether the variant segregates with the disease can be useful but is often not possible. In cases where segregation analysis is not possible, the proband must be counseled that the result is indeterminate. Given the large size of the *BRCA1* and *BRCA2* proteins it is very difficult to predict if a given amino acid change is deleterious. As our understanding of the biology of these proteins improves, functional assays to determine the impact of specific amino acid changes may be possible. (iv) Finally, analysis of an affected relative requires the willingness of the relative to receive counseling and to participate in genetic testing. This has proven to be difficult in a number of families, especially given the concerns about confidentiality of

test results and the high mobility of families within the United States.

Given the limitations of initial testing of affected relatives, some clinical programs offer testing to at-risk individuals even if a sample from an affected relative is not available. A positive test with a clearly deleterious mutation would be informative and potentially would allow the individual to make additional decisions with regard surveillance and surgery. In addition, asymptomatic relatives of that individual could be tested for the presence of the deleterious mutation. The caveat to this approach is that a negative *BRCA1* and *BRCA2* analysis does not substantially decrease the individual's risk of developing cancer. Substantial pre-test counseling is required to ensure that the patient does not misunderstand a negative test as lowering their risk of developing cancer. In addition, it must be explained clearly to the patient that the probability of finding a mutation is often <10%, before the expense and difficulty of molecular testing are undertaken.

Populations with recurring mutations. As outlined above, the presence of "private" mutations and the high complexity and cost of mutational analysis has primarily limited the use of *BRCA1* and *BRCA2* mutation testing to women with very significant family histories. Such analysis of families led to the discovery that three particular mutations (185delAG and 5382insC in *BRCA1* and 6174delT in *BRCA2*) occur at the very high frequency of one in 40 in the Ashkenazi Jewish population (28–30). Within Israel, extensive testing for all three mutations of Ashkenazi cancer patients has been performed and resulted in positive testing in nearly 30% of early-onset breast cancer patients (31) and 45% of ovarian cancer patients (32).

The relative simplicity of mutational analysis and the high frequency of these mutations has led to investigation of population-based testing (33). In one study after the discovery of the 185delAG mutation, 90% of 309 Ashkenazi individuals who chose to attend an educational session elected to have mutation testing performed. This group included both individuals with a positive family history of cancer and those without. Mutation analysis in this population (33), along with other studies (34), revealed that mutation carriers often have a family history of breast or ovarian cancer, but it may be much more limited (e.g. only postmenopausal breast cancer) than the BCLC high risk families.

Although population based testing is not being performed outside of research settings, overall, a substantial percentage of women undergoing mutational analysis for *BRCA1* and *BRCA2* mutations in the

United States are Ashkenazi Jewish. For example in the analysis by Couch, *et al.*, 10% of 263 breast cancer patients and families were Ashkenazi (18). However, not all breast cancers in highly affected Ashkenazi Jewish families can be attributed to these three high frequency mutations (35). Other "private" mutations have been identified, and, for a number of families, the dominant gene in the family remains unknown. This latter group of families may be very useful in identification of additional breast cancer susceptibility genes (36). Again, because not all families have one of the three known mutations it is still prudent to perform mutational analysis on an affected relative before testing at risk individuals in Ashkenazi families. However, given the high frequency and greater simplicity of mutation testing for these specific mutations in families where no samples are available from affected individuals analysis for the recurring mutations in at-risk individuals may be indicated.

Subsequent to the finding of the Ashkenazi mutations, recurring mutations in other populations have been identified including mutations in a number of different European and Icelandic populations (35). Within these populations, molecular testing based specifically on these mutations is being developed.

Cancer patients. Although the initial focus of screening programs was on at risk individuals, breast or ovarian cancer survivors seek mutational analysis to determine their risk of second malignancy and the probability of passing a predisposition on to their offspring. The analysis of the BCLC families revealed a 60% risk of a second breast cancer and a 38% risk of ovarian cancer by age 60 in a woman with a *BRCA1* mutation and breast cancer (37). For these individuals analysis is begun by testing their constitutional DNA directly for mutations.

THE RISK OF DEVELOPING CANCER FOR MUTATION CARRIERS

The primary clinical reason for undertaking *BRCA1* and *BRCA2* testing in at-risk individuals is the desire to define further their risk of developing cancer. Therefore, the genetic penetrance (or the likelihood of developing cancer if one has the mutation) of these specific mutations has been of intense research interest. Initial studies, especially of the BCLC families, suggested a very high age-related risk of cancer in carriers of *BRCA1* mutations with a nearly 90% risk of developing breast cancer and 40% risk of developing ovarian

Table I. Cumulative Percentage Risk for Breast and Ovarian Cancer in Mutation Carriers

	BRCA1 Narod 1995 (13)		BRCA2 Ford 1998 (17)		Ashkenazi Mutations Struewing 1997 (34)	
	Breast	Ovary	Breast	Ovary	Breast	Ovary
Age 50	49 (28-64)	16 ^a	28 (9-44)	0.4 (0-1)	33 (23-44)	7 (2-14)
Age 70	71 (53-82)	42 ^a	84 (43-95)	27 (0-47)	56 (40-73)	16 (6-28)

^a Confidence interval not reported.

cancer by age 70 (37). A recent update of these analyses including both *BRCA1* and *BRCA2* verifies the high penetrance for both breast and ovarian cancer in these families (Table I) (17). Comparison of the penetrance of *BRCA2* with *BRCA1* confirms the findings of other investigators (32,38) that the overall penetrance may be similar but the development of breast cancer occurs somewhat later in *BRCA2* mutation carriers.

However, the systematic problem in applying these cancer risks to clinical situations is that the BCLC families were specifically identified for linkage studies and therefore were known to be highly affected and to have a significant number of early-onset cases. Several other groups have published or presented penetrance data derived by different assessment methods, (reviewed by Easton 39). In particular, a population based analysis of breast and ovarian cancer in over 5000 Ashkenazi Jewish individuals revealed somewhat lower penetrance for the common mutations of 56% for breast cancer and 16% for ovarian cancer (Table I) (34). Analysis of Ashkenazi Jewish patients in Israel was based on relatives of cancer patients with confirmation of mutation status in the relatives, and revealed a somewhat higher penetrance for these mutations (40). Overall, the confidence intervals for most of these estimates overlap. The difference in penetrance estimates for specific mutations may be partly based on a population cohort versus relatives of cancer patients and partly on the different methodologies employed in obtaining and analyzing the family history.

It is difficult to identify the best risk estimate to use in counseling an individual. In particular, at risk individuals who seek counseling often have a significant family history of cancer and do not represent the population average. Therefore, their risk may in fact be higher than a risk derived from a general population-based study, because the influence of modifier genes or other factors that alter cancer risk may be present in their family. Overall, it is important for at risk indi-

viduals to understand (i) that the majority of studies have found a significantly increased risk of breast and ovarian cancer, (ii) that breast cancer occurs at an earlier age than the population average, especially for *BRCA1* mutations, (iii) that the absolute degree of risk is still under study, and (iv) that mutations result in a predisposition, but not a certainty, of developing cancer.

A second issue is the impact of mutation carrier status on the pathology and prognosis of breast cancer patients. There is controversy about the predicted survival of breast cancer patients with *BRCA1* and *BRCA2* mutations (41). Pathologic studies demonstrated that tumors from *BRCA1* mutation carriers have an increase in markers of proliferation compared with controls, patients with other hereditary breast cancer or sporadic cancers (42,43). However, their analysis did not reveal a significant difference in prognosis for *BRCA1* carrier patients compared with breast cancer patients with sporadic disease. In the same study, tumors from *BRCA2* patients did not show proliferative differences but have an increased tubular-lobular phenotype. An analysis of prognosis has recently been reported from both the Netherlands (44) and Sweden (45) demonstrating no significant survival advantage in mutation carriers. As reviewed by Watson, *et al.*, the majority of the evidence does not point to any significant difference in prognosis for *BRCA1* mutation carriers when matched with sporadic cancers for stage and age of onset (46). As the technology to detect mutations improves, and as an increased number of woman who are mutation carriers are followed, our knowledge of prognosis will improve.

RISK OF OTHER MALIGNANCIES

The initial focus on isolating the *BRCA1* and *BRCA2* genes was familial breast cancer. However, very early studies demonstrated an increased risk of

developing ovarian cancer especially in families that carry *BRCA1* mutations (1). With regard to the likelihood of detecting mutations in *BRCA1* a family history of ovarian cancer is a much better indicator than a history of breast cancer or the total number of breast cancer cases in the family (17–19). Although initial studies suggested that there may not be an increased risk of ovarian cancer in *BRCA2* families, this analysis has been revised (Table I) (4). In particular, mutations found in a central region of the *BRCA2* gene including exon 11 (termed the OCR) convey a significantly increased risk of ovarian cancer compared with mutations in either the 5' or 3' regions of the gene (47). This region of *BRCA2* includes the 6174delT common mutation in the Ashkenazi Jewish population and explains the high rate of ovarian cancer associated with this mutation. The biologic basis of this difference is unknown, and the difference is not related to mutation type, because the majority of mutations both within and outside the OCR are truncating mutations.

Given the poor prognosis of women with ovarian cancer, the finding that these mutations also increase ovarian cancer risk is potentially more disturbing to patients than the risk of developing breast cancer. One analysis suggested that the prognosis of *BRCA1* mutation carriers who developed ovarian cancer was improved compared with non-mutation carriers (48). Several other groups have not found such a survival advantage (45) as reviewed by Lynch and Watson (49) when using a variety of methods to ascertain cases and controls. Analysis of larger number of ovarian cancer patients with mutations will be required to further clarify this area.

In addition to the clear occurrence of ovarian cancer, more recent studies have suggested that *BRCA1* and *BRCA2* mutations confer different risks of other malignancies. Initial analysis of colon cancer and prostate cancer in *BRCA1* families has demonstrated relative risks of four and three, respectively, for mutation carriers in the BCLC (50). These risks have not been confirmed in other large series, and there are no current recommendations for increased screening over that recommended for the general population (51). Ashkenazi Jewish individuals with pancreatic cancer are significantly more likely to carry the 6174delT mutation in *BRCA2* than the general Ashkenazi population with an odds ratio of 8.3 (95% C.I. 2.2–23) (52). The increase in pancreatic cancer has not yet been confirmed in other studies but *BRCA2* was initially cloned partially based on a homozygous deletion of that gene in a pancreatic cancer (53). As is the case with ovarian

cancer, knowledge of an increased risk of pancreatic cancer is likely to be extremely troubling to individuals seeking risk assessment. Subsequent analysis of larger cohorts of mutation carriers will help clarify the risk of these malignancies and may expose additional cancer risks.

SURVEILLANCE AND TREATMENT GUIDELINES

One goal of *BRCA1* and *BRCA2* mutation testing is the identification of high-risk women who can be targeted for early surveillance and potentially also for prevention strategies. A number of surveillance guidelines have been used by different centers including early use of mammograms and screening for ovarian cancer. A panel of experts convened by The National Human Genome Research Institute published surveillance guidelines in 1997 (Table II) (51). As discussed by the authors, there is little data that clearly demonstrates a decrease in either morbidity or mortality for women who undergo intensive screening. However, there is a general consensus that increased surveillance should be offered to all women who are known carriers of *BRCA1* and *BRCA2* mutations or who are at substantial risk to carry such a mutation. The finding that the *BRCA1* and *BRCA2* proteins may play a role in DNA repair has led to concern about a potential increase in radiation induced tumors with frequent mammograms. In a recent study of young Ashkenazi Jewish women breast cancer patients Rabson, *et al.* (54) examined ipsilateral breast cancer recurrence in women treated by lumpectomy with radiation therapy. It is reassuring that there was no significant difference in recurrence in the irradiated breast between mutation carriers and non-carriers.

Much more controversial is the question of either chemoprevention or prophylactic surgery for these at

Table II. Recommended Surveillance Guidelines for High Carriers of *BRCA1* and *BRCA2* Mutations^a

Examination	Timing
Breast self-exam	monthly
Clinical breast exam	q6–12 months beginning at age 25–35
Mammography	q6–12 months beginning at age 25–35
Serum CA125	q6–12 months beginning at age 25–35
Transvaginal ultrasound	q6–12 months beginning at age 25–35

^a Data taken from Burke 1997 (51).

risk women. The consensus panel did not find sufficient data to recommend for or against mastectomy or oophorectomy. However, an NIH consensus panel on ovarian cancer screening and treatment did recommend prophylactic oophorectomy for women from autosomal dominant cancer families by age 36 or after childbearing is completed (55). There are no large studies that specifically examine the outcome of prophylactic oophorectomy in mutation carriers or the risk of peritoneal carcinomatosis that can occur after oophorectomy, but smaller studies have suggested anywhere from a 50%–80% reduction in risk (56,57).

With regard to prophylactic mastectomy, there appear to be regional differences in the degree to which patients elect to undergo prophylactic surgery, and a number of these operations are performed on women who have neither undergone molecular testing nor been enrolled in a research study. A follow-up of approximately 2029 women who underwent the procedure at one center since 1960 has been published in abstract form (58). There were 11 subsequent breast cancers in the 1125 patients for which complete data was available, which is significantly below that expected for the general population. However, these individuals based their decision to undergo the procedure on a variety of medical (multiple biopsies) and family history factors. The number of women in this cohort who are mutation carriers is not currently known. A separate purely statistical analysis based on penetrance, expected cancer survival etc., demonstrated an average survival advantage of four years for women who were *BRCA1* carriers who had a prophylactic mastectomy at age 40 (59). They also found that prophylactic oophorectomy would result in a one year increase in survival. More recently an analysis that took into account a quality of life variable predicted that there may be a decreased (but still positive) overall benefit of prophylactic surgery. However, it is not clear whether the decrease in quality of life used in the study is accurate for high-risk women undergoing prophylactic surgery (60).

A related issue for future research is the utility of performing mutational analysis immediately after diagnosis in an individual with pre-menopausal breast cancer to determine whether it would be beneficial to perform mastectomy as opposed to lumpectomy on the affected breast and to consider prophylactic mastectomy of the contralateral side. This type of protocol would require a rapid turnaround time (more likely for analysis of common mutations) and a reasonable likelihood of finding a mutation. Given the low proportion of mutations in series of young breast cancer

patients (20) this protocol would not likely change the therapy in a large proportion of women.

Over the last few months there have been new developments in the question of chemoprevention for women at high risk. The initial results of the Breast Cancer Prevention Trial (BCPT) have been released in the media after participants were sent letters unblinding the results. This study examined the impact of oral tamoxifen on women who were at high risk based on a number of factors including family history, number of biopsies and pathology on biopsies. It is not known how many of these women are carriers of *BRCA1* and *BRCA2* mutations. However, tamoxifen did decrease the number of breast cancers by approximately 45% in this high risk group. The decrease in breast cancer was accompanied by some increase in endometrial cancers. Further analysis of the BCPT and other studies may result in the recommendation for chemopreventative agents in mutation carriers.

CURRENT RESEARCH QUESTIONS

The incredibly rapid pace of research concerning testing for mutations in the *BRCA1* and *BRCA2* genes obscures the fact that these genes were only cloned approximately three years ago. Thus, we are still in the very early stages of understanding the natural history of carriers of these mutations or the long-term impact of testing on individuals who undergo testing. With regard to the latter question the development of longitudinal protocols to follow individuals who have been tested should continue to provide new information. It will be important for these protocols to accrue more participants who are not from "research" families but more resemble the type of "high risk" patient seen in primary care offices.

Perhaps the most obvious question as yet unanswered is what modifies the risk of malignancy. The problem is illustrated by a family seen in our clinic in which one woman developed breast cancer at age 34 and 10 years later was found to carry a truncating mutation in *BRCA1*. Her identical twin (who presumably shares both major and modifying genes) remains cancer free. There is enormous interest in understanding the factors that may determine whether a mutation carrier develops breast cancer at an early age, ovarian cancer, multiple malignancies or no malignancy at all. For example, one small study of Ashkenazi Jewish breast cancer patients suggested that use of oral contraceptives increased the risk of developing cancer in

women carrying one of the recurrent mutations (61). Analysis of a large cohort of mutation carriers is necessary to determine the impact of reproductive factors, hormone therapy and other lifestyle choices on cancer risk. The creation of the National Cancer Institute Cancer Genetics Network should facilitate these types of studies which require large numbers of mutation carriers. One of the first analyses specifically examining breast cancer risk in mutation carriers has reported a statistically significant decrease in breast cancer development with cigarette smoking (62). An odds ratio of 0.46 for carriers with more than a four pack-year history compared to non-smokers was found. The mechanism of this protection is unclear but may be related to anti-estrogenic activity in cigarette smoke

In addition to environmental factors, studies to determine whether specific modifier genes alter the risk are underway to identify the genetic components that alter cancer susceptibility. One example is the finding that certain rare alleles of the *HRAS1* locus are associated with an increase risk of ovarian cancer in *BRCA1* mutation carriers (63). Recently, the length of a CAG repeat in the androgen receptor gene has been associated with the age of onset of breast cancer in *BRCA1* carriers. Women with at least one long repeat have significantly earlier onset than those with two shorter alleles (64).

Finally, for the at risk women who enter these studies, better definition of what modifies the risk of malignancy will result in improved counseling about their individual risk and the potential to minimize the risk of cancer that is substantially elevated due to the presence of a mutation in *BRCA1* or *BRCA2*.

ACKNOWLEDGMENTS

The author acknowledges support from the Susan G. Komen Breast Cancer Foundation and the Department of Defense DAMD17-97-7284.

REFERENCES

1. J. M. Hall, M. K. Lee, B. Newman, J. E. Morrow, L. A. Anderson, B. Huey, and M. C. King (1990). Linkage of early-onset familial breast cancer to chromosome 17q21. *Science* **250**:1684-1689.
2. R. Wooster, S. Neuhausen, J. Manigion, Y. Quirk, D. Ford, N. Collins, and K. Nguyen (1994). Localisation of a breast cancer susceptibility gene (*BRCA2*) to chromosome 13q by genetic linkage analysis. *Science* **265**:2088-2090.
3. Y. Miki, J. Swensen, D. Schattuck-Eidens, P. A. Futreal, K. Harshman, S. Tavtigian, Q. Y. Liu, C. Cochran, L. M. Bennett, W. Ding, R. Bell, J. Rosenthal, C. Hussey, T. Tran, H. McClure, C. Frye, T. Hattier, R. Phelps, A. Haugen-Strano, H. Katcher, K. Yakumo, Z. Gholami, D. Shaffer, S. Stone, S. Bayer, C. Wray, R. Borgden, P. Dayananth, J. Ward, P. Tonin, S. Narod, P. Bristow, F. Norris, L. Helvering, P. Morrison, P. Roseteck, M. Lai, J. C. Barrett, C. Lewis, S. Neuhausen, L. Canon-Albright, D. Goldgar, R. Wiseman, A. Kamb, and M. H. Skolnick (1994). Isolation of *BRCA1*, the 17q-linked breast and ovarian cancer susceptibility gene. *Science* **266**:66-71.
4. R. Wooster, G. Bignell, J. Lancaster, S. Swift, S. Seal, J. Mangion, N. Collins, S. Gregory, C. Gumbs, G. Micklem, R. Barfoot, R. Hamoudi, S. Patel, C. Rice, P. Biggs, Y. Hashim, A. Smith, F. Connor, A. Arason, J. Gudmundsson, D. Ficene, D. Kelsell, D. Ford, P. Tonin, D. T. Bishop, N. K. Spurr, B. A. J. Ponder, R. Eeles, J. Peto, P. Devilee, C. Cornelisse, H. Lynch, S. Narod, G. Lenoir, V. Egilsson, R. B. Barkadottir, D. F. Easton, D. R. Bentley, P. A. Futreal, A. Ashworth, and M. R. Stratton (1995). Identification of the breast cancer susceptibility gene *BRCA2*. *Nature* **378**:789-792.
5. M. A. Rothstein (1995). Genetic testing: employability, insurability, and health reform. *J. Natl. Cancer Inst. Monogr.* **17**:87-90.
6. K. Rothenberg, B. Fuller, M. Rothstein, T. Duster, M. J. E. Kahn, R. Cunningham, B. Fine, K. Hudson, M. C. King, P. Murphy, G. Swergold, and F. Collins (1997). Genetic information and the workplace: Legislative approaches and policy challenges. *Science* **275**:1755-1757.
7. Statement of the American Society of Human Genetics on genetic testing for breast and ovarian cancer predisposition (1994). *Am. J. Hum. Genet.* **55**:1-14.
8. Statement of the American Society of Clinical Oncology: Genetic testing for cancer susceptibility. Adopted on February 20, 1996 (1996). *J. Clin. Oncol.* **14**:1730-1736.
9. E. Kodish, G. L. Wiesner, M. Mehlman, and T. Murray (1998). Genetic testing for cancer risk. How to reconcile the conflicts. *J.A.M.A.* **279**:179-181.
10. H. T. Lynch, J. N. Marcus, P. Watson, and J. Lynch (1991). Familial breast cancer, family cancer syndromes, and predisposition to breast neoplasia. In K. I. Bland and E. M. I. Copeland (eds.), *The Breast: Comprehensive Management of Benign and Malignant Diseases*, W. B. Saunders Co., New York, pp. 262-291.
11. M. H. Gail, L. A. Brinton, D. P. Byar, D. K. Corle, S. B. Green, C. Schairer, and J. J. Mulvihill (1989). Projecting individualized probabilities of developing breast cancer for white females who are being examined annually. *J. Natl. Cancer Inst.* **81**:1879-1886.
12. P. M. Conneally, (1990). Huntington disease. In A. E. H. Emery and D. L. Rimoim (eds.), *Principles and Practice of Medical Genetics*, Churchill Livingstone, Edinburgh, pp. 373-382.
13. S. A. Narod, D. Ford, P. Devilee, R. B. Barkadottir, H. T. Lynch, S. A. Smith, B. A. J. Ponder, B. L. Weber, J. E. Garber, J. M. Birch, R. S. Cornelis, D. P. Kelsell, N. K. Spurr, E. Smyth, N. Haites, H. Sobol, Y. J. Bignon, J. Chang-Claude, U. Hamann, A. Lindblom, A. Borg, M. S. Piver, H. H. Gallion, J. P. Struwing, A. Whittemore, P. Tonin, D. E. Goldgar, D. F. Easton, and Breast Cancer Linkage Consortium (1995). An evaluation of genetic heterogeneity in 145 breast-ovarian cancer families. *Am. J. Hum. Genet.* **56**:254-264.
14. M. Durner, D. A. Greenberg, and S. E. Hodge (1996). Phenocopies versus genetic heterogeneity: Can we use phenocopy frequencies in linkage analysis to compensate for heterogeneity? *Hum. Hered.* **46**:265-273.
15. B. B. Biesecker, M. Boehnke, K. Calzone, D. S. Markel, J. E. Gerber, F. S. Collins, and B. L. Weber (1993). Genetic

- counseling for families with inherited susceptibility to breast and ovarian cancer. *J. A. M. A.* **269**:1970-1974.
16. D. Shattuck-Eidens, M. McClure, J. Simard, F. Labrie, S. Narod, F. Couch, K. Hoskins, B. Weber, L. Castilla, M. Erdos, L. Brody, L. Friedman, E. Ostermeyer, C. Szabo, M. C. King, S. Jhanwar, K. Offit, L. Norton, T. Gilewski, M. Lubin, M. Osborne, D. Black, M. Boyd, M. Steel, S. Ingles, R. Haile, A. Lindblom, H. Olsson, A. Borg, D. T. Bishop, E. Solomon, P. Radice, G. Spatti, S. Gayther, B. Ponder, W. Warren, M. Stratton, Q. Liu, F. Fujimura, C. Lewis, M. H. Skolnick, and D. E. Goldgar (1995). A collaborative survey of 80 mutations in the *BRCA1* breast and ovarian cancer susceptibility gene. Implications for presymptomatic testing and screening. *J.A.M.A.* **273**:535-541.
 17. D. Ford, D. F. Easton, M. Stratton, S. Narod, D. Goldgar, P. Devilee, D. T. Bishop, B. Weber, G. Lenoir, J. Chang-Claude, H. Sobol, M. D. Teare, J. Struewing, A. Arason, S. Scherneck, J. Peto, T. R. Rebbeck, P. Tonin, S. Neuhausen, R. Barkardottir, J. Eyfjord, H. Lynch, B. A. J. Ponder, S. A. Gayther, J. M. Birch, A. Lindblom, D. Stoppa-Lyonnet, Y. Bignon, A. Borg, U. Hamann, N. Haites, R. J. Scott, C. M. Maugard, H. Vasen, S. Seitz, L. A. Cannon-Albright, A. Schofield, M. Zelada-Hedman, and Breast Cancer Linkage Consortium (1998). Genetic heterogeneity and penetrance analysis of the *BRCA1* and *BRCA2* genes in breast cancer families. *Am. J. Hum. Genet.* **62**:676-689.
 18. F. J. Couch, M. L. DeShano, M. A. Blackwood, K. Calzone, J. Stopfer, L. Campeau, A. Ganguly, T. Rebbeck, and B. L. Weber (1997). *BRCA1* mutations in women attending clinics that evaluate the risk of breast cancer. *N. Engl. J. Med.* **336**:1409-1415.
 19. D. Shattuck-Eidens, A. Oliphant, M. McClure, C. McBride, J. Gupte, T. Rubano, D. Pruss, S. V. Tavtigian, D. H. F. Teng, N. Adey, M. Staebell, K. Gumpfer, R. Lundstrom, M. Hulick, M. Kelly, J. Holmen, B. Lingenfelter, S. Manley, F. Fujimura, M. Luce, B. Ward, L. Cannon-Albright, L. Steele, K. Offit, T. Gilewski, L. Norton, K. Brown, C. Schulz, H. Hampel, A. Schluger, E. Guilotto, W. Zoli, A. Ravaoli, H. Nevanlinna, S. Pyrhonen, P. Rowley, S. Loader, M. P. Osborne, M. Daly, I. Tepler, P. L. Weinstein, J. L. Scalia, R. Michaelson, R. J. Scott, P. Radice, M. A. Pierotti, J. E. Garber, C. Isaacs, B. Peshkin, M. E. Lippman, M. H. Dosik, M. A. Caligo, R. M. Greenstein, R. Pilarski, B. Weber, R. Burgemeister, T. S. Frank, M. H. Skolnick, and A. Thomas (1997). *BRCA1* sequence analysis in women at high risk for susceptibility mutations. Risk factor analysis and implications for genetic testing. *J.A.M.A.* **278**:1242-1250.
 20. F. S. Collins (1996). *BRCA1*—Lots of mutations, lots of dilemmas. *N. Engl. J. Med.* **334**:186-188.
 21. A. S. Whittemore, G. Gong, and J. Itnyre (1997). Prevalence and contribution of *BRCA1* mutations in breast cancer and ovarian cancer: Results from three U.S. population-based case-control studies of ovarian cancer. *Am. J. Hum. Genet.* **60**:496-504.
 22. H. Chaliki, S. Loader, J. C. Levenkron, W. Logan-Young, W. J. Hall, and P. T. Rowley (1995). Women's receptivity to testing for a genetic susceptibility to breast cancer. *Am. J. Public Health* **85**:1133-1135.
 23. C. Lerman, S. Narod, K. Schulman, C. Hughes, A. Gomez-Caminero, G. Bonney, K. Gold, B. Trock, D. Main, J. Lynch, C. Fulmore, C. Snyder, S. J. Lemon, T. Conway, P. Tonin, G. Lenoir, and H. Lynch (1996). *BRCA1* testing in families with hereditary breast-ovarian cancer. A prospective study of patient decision making and outcomes. *J.A.M.A.* **275**:1885-1892.
 24. R. T. Croyle, J. S. Achilles, and C. Lerman (1997). Psychologic aspects of cancer genetic testing—A research update for clinicians. *Cancer* **80**:569-575.
 25. C. Lerman, M. D. Schwartz, T. H. Lin, C. Hughes, S. Narod, and H. T. Lynch (1997). The influence of psychological distress on use of genetic testing for cancer risk. *J. Consult. Clin. Psychol.* **65**:414-420.
 26. C. Lerman, C. Hughes, S. J. Lemon, D. Main, C. Snyder, C. Durham, S. A. Narod, and H. T. Lynch (1998). What you don't know can hurt you: Adverse psychologic effects in members of *BRCA1*-linked and *BRCA2*-linked families who decline genetic testing. *J. Clin. Oncol.* **16**:1650-1654.
 27. F. M. Giardiello, J. D. Brensinger, G. M. Petersen, M. C. Luce, L. M. Hyland, J. A. Bacon, S. V. Booker, R. D. Parker, and S. R. Hamilton (1997). The use and interpretation of commercial APC gene testing for familial adenomatous polyposis. *N. Engl. J. Med.* **336**:823-827.
 28. J. P. Struewing, D. Abeliovich, T. Peretz, N. Avishai, M. M. Kaback, F. S. Collins, and L. C. Brody (1995). The carrier frequency of the *BRCA1* 185delAG mutation is approximately 1 percent in Ashkenazi Jewish individuals. *Nat. Genet.* **11**:198-200.
 29. C. Oddoux, J. P. Struewing, C. M. Clayton, S. Neuhausen, L. C. Brody, M. Kaback, B. Haas, L. Norton, P. Borgen, S. Jhanwar, D. Goldgar, H. Ostrer, and K. Offit (1996). The carrier frequency of the *BRCA2* 6174delT mutation among Ashkenazi Jewish individuals is approximately 1%. *Nat. Genet.* **14**:188-190.
 30. B. B. Roa, A. A. Boyd, K. Volcik, and C. S. Richards (1996). Ashkenazi Jewish population frequencies for common mutations in *BRCA1* and *BRCA2*. *Nat. Genet.* **14**:185-187.
 31. D. Abeliovich, L. Kaduri, I. Lerer, N. Weinberg, G. Amir, M. Sagi, J. Zlotogora, N. Heching, and T. Peretz (1997). The founder mutations 185delAG and 5382insC in *BRCA1* and 6174delT in *BRCA2* appear in 60% of ovarian cancer and 30% of early-onset breast cancer patients among Ashkenazi women. *Am. J. Hum. Genet.* **60**:505-514.
 32. E. Levy-Lahad, R. Catane, S. Eisenberg, B. Kaufman, G. Hornreich, E. Lishinsky, M. Shohat, B. L. Weber, U. Beller, A. Lahad, and D. Halle. (1997). Founder *BRCA1* and *BRCA2* mutations in Ashkenazi Jews in Israel: Frequency and differential penetrance in ovarian cancer and in breast-ovarian cancer families. *Am. J. Hum. Genet.* **60**:1059-1067.
 33. C. S. Richards, P. A. Ward, B. B. Roa, L. C. Friedman, A. A. Boyd, G. Kuenzli, J. K. Dunn, and S. E. Plon (1997). Screening for 185delAG in the Ashkenazim. *Am. J. Hum. Genet.* **60**:1085-1098.
 34. J. P. Struewing, P. Hartge, S. Wacholder, S. M. Baker, M. Berlin, M. McAdams, M. M. Timmerman, L. C. Brody, and M. A. Tucker (1997). The risk of cancer associated with specific mutations of *BRCA1* and *BRCA2* among Ashkenazi Jews. *N. Engl. J. Med.* **336**:1401-1408.
 35. C. I. Szabo and M. C. King (1997). Population genetics of *BRCA1* and *BRCA2*. *Am. J. Hum. Genet.* **60**:1013-1020.
 36. O. M. Serova, S. Mazoyer, N. Puget, V. Dubois, P. Tonin, Y. Y. Shugart, D. Goldgar, S. A. Narod, H. T. Lynch, and G. M. Lenoir (1997). Mutations in *BRCA1* and *BRCA2* in breast cancer families: Are there more breast cancer-susceptibility genes? *Am. J. Hum. Genet.* **60**:486-495.
 37. D. F. Easton, D. Ford, D. T. Bishop, and Breast Cancer Linkage Consortium (1995). Breast and ovarian cancer incidence in *BRCA1*-mutation carriers. *Am. J. Hum. Genet.* **56**:265-271.
 38. M. Krainer, S. Silva-Arrieta, M. G. FitzGerald, A. Shimada, C. Ishioka, R. Kanamaru, D. J. MacDonald, H. Unsal, D. M. Finkelstein, A. Bowcock, K. J. Isselbacher, and D. A. Haber (1997). Differential contributions of *BRCA1* and *BRCA2* to early-onset breast cancer. *N. Engl. J. Med.* **336**:1416-1421.
 39. D. Easton (1997). Breast cancer genes—what are the real risks? *Nat. Genet.* **16**:210-211.
 40. E. Levy-Lahad, R. Gershoni-Baruch, M. Sagi, A. Orr-Urtreger, A. Ben-Yehuda, E. Dagan, R. Bar-Sade, A. Lahad, D. Halle,

- T. Peretz, and E. Friedman (1997). Directly derived penetrance estimates for the founder BRCA1/BRCA2 mutations in Jews: The Israeli consortium on hereditary breast cancer. *Am. J. Hum. Genet.* **61**:A72.
41. P. Tonin, B. Weber, K. Offit, F. Couch, T. R. Rebbeck, S. Neuhausen, A. K. Godwin, M. Daly, J. Wagner-Costalos, D. Berman, G. Grana, E. Fox, M. F. Kane, R. D. Kolodner, M. Krainer, D. A. Haber, J. P. Struewing, E. Warner, B. Rosen, C. Lerman, B. Peshkin, L. Norton, O. Serova, W. D. Foulkes, and J. E. Garber (1996). Frequency of recurrent BRCA1 and BRCA2 mutations in Ashkenazi Jewish breast cancer families. *Nat. Med.* **2**:1179-1183.
 42. J. N. Marcus, P. Watson, D. L. Page, S. A. Narod, G. M. Lenoir, P. Tonin, L. Linder-Stephenson, G. Salerno, T. A. Conway, and H. T. Lynch (1996). Hereditary breast cancer. Pathobiology, prognosis, and BRCA1 and BRCA2 gene linkage. *Cancer* **77**:697-709.
 43. J. N. Marcus, D. L. Page, P. Watson, S. A. Narod, G. M. Lenoir, and H. T. Lynch (1997). BRCA1 and BRCA2 hereditary breast carcinoma phenotypes. *Cancer* **80**:543-556.
 44. L. C. Verhoog, C. T. M. Brekelmans, C. Seynaeve, L. M. C. van den Bosch, G. Dahmen, A. N. van Geel, M. M. A. Tilanus-Linthorst, C. C. M. Bartels, A. Wagner, A. van den Ouweland, P. Devilee, E. J. Meijers-Heijboer, and J. G. M. Klijn (1998). Survival and tumour characteristics of breast-cancer patients with germline mutations of BRCA1. *Lancet* **351**:316-321.
 45. O. T. Johannsson, J. Ranstam, A. Borg, and H. Olsson (1998). Survival of BRCA1 breast and ovarian cancer patients: A population-based study from southern Sweden. *J. Clin. Oncol.* **16**:397-404.
 46. P. Watson, J. N. Marcus, and H. T. Lynch (1998). Prognosis of BRCA1 hereditary breast cancer. *Lancet* **351**:304-305.
 47. S. A. Gayther, J. Mangion, P. Russell, S. Seal, R. Barfoot, B. A. Ponder, M. R. Stratton, and D. Easton (1997). Variation of risks of breast and ovarian cancer associated with different germline mutations of the BRCA2 gene. *Nat. Genet.* **15**:103-105.
 48. S. C. Rubin, I. Benjamin, K. Behbakht, H. Takahashi, M. A. Morgan, V. A. LiVolsi, A. Berchuck, M. G. Muto, J. E. Garber, B. L. Weber, H. T. Lynch, and J. Boyd (1996). Clinical and pathological features of ovarian cancer in women with germline mutations of BRCA1. *N. Engl. J. Med.* **335**:1413-1416.
 49. H. T. Lynch and P. Watson (1998). BRCA1, pathology, and survival. *J. Clin. Oncol.* **16**:395-396.
 50. D. Ford, D. F. Easton, D. T. Bishop, S. A. Narod, and D. E. Goldgar (1994). Risks of cancer in BRCA1-mutations carriers. Breast Cancer Linkage Consortium. *Lancet* **343**:692-695.
 51. W. Burke, M. Daly, J. Garber, J. Botkin, M. J. E. Kahn, P. Lynch, A. McTiernan, K. Offit, J. Perlman, G. Petersen, E. Thomson, and C. Varricchio (1997). Recommendations for follow-up care of individuals with an inherited predisposition to cancer: II. BRCA1 and BRCA2. *J.A.M.A.* **277**:997-1003.
 52. H. Ozelik, B. Schmocker, N. Di Nicola, X. H. Shi, B. Langer, M. Moore, B. R. Taylor, S. A. Narod, G. Darlington, I. L. Andrulis, S. Gallinger, and M. Redston (1997). Germline BRCA2 6174delT mutations in Ashkenazi Jewish pancreatic cancer patients. *Nat. Genet.* **16**:17-18.
 53. M. Schutte, L. T. da Costa, S. A. Hahn, C. Moskaluk, A. T. Hoque, E. Rozenblum, C. L. Weinstein, M. Bittner, P. S. Meltzer, and J. M. Trent (1995). Identification by representational difference analysis of a homozygous deletion in pancreatic carcinoma that lies within the BRCA2 region. *Proc. Natl. Acad. Sci. U. S. A.* **92**:5950-5954.
 54. M. Robson, T. Gilewski, B. Haas, D. Levin, P. Borgen, P. Rajan, Y. Hirschaut, P. Pressman, P. P. Rosen, M. L. Lesser, L. Norton, and K. Offit (1998). BRCA-Associated Breast Cancer in Young Women. *J. Clin. Oncol.* **16**:1642-1649.
 55. NIH Consensus Development Panel on Ovarian Cancer (1995). Ovarian cancer. Screening, treatment, and follow-up. *J.A.M.A.* **273**:491-497.
 56. J. P. Struewing, P. Watson, D. F. Easton, B. A. J. Ponder, H. T. Lynch, and M. A. Tucker (1995). Prophylactic oophorectomy in inherited breast/ovarian cancer families. *J. Natl. Cancer Inst. Monogr.* **17**:33-35.
 57. M. S. Piver and C. Wong (1998). Role of prophylactic surgery for women with genetic predisposition to cancer. *Clin. Obstet. Gynecol.* **41**:215-224.
 58. L. Hartmann, R. Jenkins, D. Schaid, and P. Yang (1997). Prophylactic mastectomy (PM): Preliminary retrospective cohort analysis. *Am. Assoc. Cancer Res.* **38**:A168.
 59. D. Schrag, K. M. Kuntz, J. E. Garber, and J. C. Weeks (1997). Decision analysis—Effects of prophylactic mastectomy and oophorectomy on life expectancy among women with BRCA1 or BRCA2 mutations. *N. Engl. J. Med.* **336**:1465-1471.
 60. V. R. Grann, K. S. Panageas, W. Whang, K. H. Antman, and A. I. Neugut (1998). Decision analysis of prophylactic mastectomy and oophorectomy in BRCA1-positive or BRCA2-positive patients. *J. Clin. Oncol.* **16**:979-985.
 61. G. Ursin, B. E. Henderson, R. W. Haile, M. C. Pike, N. Zhou, A. Diep, and L. Bernstein (1997). Does oral contraceptive use increase the risk of breast cancer in women with BRCA1/BRCA2 mutations more than in other women? *Cancer Res.* **57**:3678-3681.
 62. J. S. Brunet, P. Ghadirian, T. R. Rebbeck, C. Lerman, J. E. Garber, P. N. Tonin, J. Abrahamson, W. D. Foulkes, M. Daly, J. Wagner-Costalos, A. K. Godwin, O. I. Olopade, R. Moslehi, A. Liede, P. A. Futreal, B. L. Weber, G. M. Lenoir, H. T. Lynch, and S. A. Narod (1998). Effect of smoking on breast cancer carriers of mutant BRCA1 or BRCA2 genes. *J. Natl. Cancer Inst.* **90**:761.
 63. C. M. Phelan, T. R. Rebbeck, B. L. Weber, P. Devilee, M. H. Rutledge, H. T. Lynch, G. M. Lenoir, M. R. Stratton, D. F. Easton, B. A. J. Ponder, L. Cannon-Albright, C. Larsson, D. E. Goldgar, and S. A. Narod (1996). Ovarian cancer risk in BRCA1 carriers is modified by the HRAS1 variable number of tandem repeat (VNTR) locus. *Nat. Genet.* **12**:309-311.
 64. T. R. Rebbeck, P.W. Kantoff, K. Krithivas, S.A. Narod, A.K. Godwin, M. B. Kaly, J. E. Garber, B. L. Weber, and M. A. Brown (1998). Modification of breast cancer risk in BRCA1 mutation carriers by the androgen receptor CAG repeat polymorphism. *Am. Assoc. Cancer Res.* **39**:A366.