

**REPORT DOCUMENTATION PAGE**Form Approved  
OMB No. 074-0188

Public reporting burden for this collection of information is estimated to average 1 hour per response, including the time for reviewing instructions, searching existing data sources, gathering and maintaining the data needed, and completing and reviewing this collection of information. Send comments regarding this burden estimate or any other aspect of this collection of information, including suggestions for reducing this burden to Washington Headquarters Services, Directorate for Information Operations and Reports, 1215 Jefferson Davis Highway, Suite 1204, Arlington, VA 22202-4302, and to the Office of Management and Budget, Paperwork Reduction Project (0704-0188), Washington, DC 20503

1. AGENCY USE ONLY (Leave blank)	2. REPORT DATE 21 March 2000	3. REPORT TYPE AND DATES COVERED Symposium Paper 21-23 March 2000
----------------------------------	---------------------------------	--

4. TITLE AND SUBTITLE  A Roadmap for Performance-Based Ship Systems Engineering	5. FUNDING NUMBERS
---	--------------------

6. AUTHOR(S)  David D. White, P.E. , James A. Hill, P.E. , and Thomas F. Copsy
--

7. PERFORMING ORGANIZATION NAME(S) AND ADDRESS(ES)  Naval Sea Systems Command 2531 Jefferson Davis Highway Code 05Q Arlington, VA 22202	8. PERFORMING ORGANIZATION REPORT NUMBER  N/A
--	---

9. SPONSORING / MONITORING AGENCY NAME(S) AND ADDRESS(ES)  Naval Surface Warfare Center Dahlgren Division 17320 Dahlgren Road Code N10 Dahlgren VA 22448-5100	10. SPONSORING / MONITORING AGENCY REPORT NUMBER  N/A
---	---

11. SUPPLEMENTARY NOTES  
Prepared for the Engineering the Total Ship (ETS) 2000 Symposium held in Gaithersburg, Md. at the National Institute of Standards & Technology and sponsored by the Naval Surface Warfare Center & the American Society of Naval Engineers

12a. DISTRIBUTION / AVAILABILITY STATEMENT  Distribution Statement A: Approved for public release: Distribution is unlimited	12b. DISTRIBUTION CODE  A
--	---------------------------------

13. ABSTRACT (Maximum 200 Words)

There is a need to assure that valuable ship design corporate memory and lessons learned are not lost in today's performance-based procurement environment. The ship acquisition and engineering community desires a common technical baseline that can assist in development of ship performance-based specifications and related acquisition requirements. Studies and surveys also indicate a desire for better guidance in the integration of the various emerging acquisition initiatives within the complex ship acquisition environment. The NAVSEA sponsored Ship Systems Engineering Project (SSEP) Roadmap navigates a new path that facilitates use of best commercial practices, retains valuable lessons learned, and provides a practical tool-set that enables development of best-value ship procurements.

20000503 113

14. SUBJECT TERMS Acquisition Reform; Naval Vessel Rules; Standardization Improvement; Ship Systems Engineering; Systems Engineering	15. NUMBER OF PAGES 14
	16. PRICE CODE

17. SECURITY CLASSIFICATION OF REPORT UNCLASSIFIED	18. SECURITY CLASSIFICATION OF THIS PAGE UNCLASSIFIED	19. SECURITY CLASSIFICATION OF ABSTRACT UNCLASSIFIED	20. LIMITATION OF ABSTRACT UL
---	--	---	----------------------------------

NSN 7540-01-280-5500

Standard Form 298 (Rev. 2-89)  
Prescribed by ANSI Std. Z39-18  
298-102

DTIC QUALITY INSPECTED 3

AQ U00-08-1943

## A ROADMAP FOR PERFORMANCE-BASED SHIP SYSTEMS ENGINEERING

### ABSTRACT

The Under Secretary of Defense for Acquisition and Technology's (USD(A&T)) *Into the 21<sup>st</sup> Century – A Strategy for Affordability* emphasizes the fielding of high quality products quickly, supporting them responsively, at lower total ownership costs. The Secretary of the Navy's Acquisition Reform Vision is to achieve military superiority at reduced cost with increased responsiveness and to integrate the military and commercial industrial bases. Acquisition Reform (AR) initiatives including Specifications and Standards reform, Integrated Product and Process Development (IPPD), and Single Process Initiative, have been implemented to varying degrees within recent ship acquisition programs with the real results in warfighter satisfaction and Total Ownership Cost (TOC) reduction to be determined.

There is a need to assure that valuable ship design corporate memory and lessons learned are not lost in today's performance-based procurement environment. The ship acquisition and engineering community desires a common technical baseline that can assist in development of ship performance-based specifications and related acquisition requirements. Studies and surveys also indicate a desire for better guidance in the integration of the various emerging acquisition initiatives within the complex ship acquisition environment. The Naval Sea Systems Command's (NAVSEA) sponsored Ship Systems Engineering Project (SSEP) Roadmap navigates a new path that facilitates use of best commercial practices, retains valuable lessons learned, and provides a practical tool-set that enables development of best-value ship procurements.

### INTRODUCTION

Navy ship acquisition traditionally has produced world class products but often with attendant lengthy cycle times. Ship systems engineering usually focused more on the "engineering" vice the systems aspect in that related disciplines such as life cycle support and producibility often took a backseat to the pure engineering functions. Life cycle support costs were not the responsibility of Ship Project Managers (SPMs). Given the generous cold-war budget environment, the Navy and industrial shipbuilding communities were not prone to adopting cost and time saving process innovations.

Acquisition Reform has dramatically changed this environment. Today the emphasis is on commercial practices, performance-based specifications, IPPD, and TOC reduction. Ship acquisition managers have applied different approaches in implementation of these initiatives. DoD downsizing and workforce attrition is reducing the size of the Navy design community. Use of performance-based specifications, conversion to commercial practices, and reductions in the Navy workforce all endanger retention of valuable Navy shipbuilding corporate knowledge.

To continue to produce world-class products and to become more competitive, the Navy's ship systems engineering process must adapt to the emerging business environment. The NAVSEA Command Standards Executive Office (NAVSEA 05Q) initiated the SSEP in 1999 to provide a practical tool-set that will guide development of future ship performance-based procurement packages while retaining corporate ship design lessons learned.

## **STANDARDIZATION IMPROVEMENT PROGRAM**

Over the last five years, the Navy Standards Improvement Program has redefined the methods by which many of our requirements are expressed. Performance-based terminology and Non-Government Standards (NGS) are today's preferred methods of standardization. Although we have rewritten many component level documents using this approach, we have not yet redefined and standardized our requirements for ships as a whole.

Over the past two decades, the military market share for many industrial products has dropped significantly when compared to the commercial share of the markets. This is especially true in electronics. This loss of market share could result in increased military product costs, or system redesign costs, that cannot be afforded within today's shrinking budgets. The "flip side" to this is that many military products do have strong commercial market counterparts. In addition to electronics, this includes land vehicles, aircraft, and other products. Various Non-Government Standards (NGS) bodies support commercial standardization for these industries.

DoD 4120.3-M defines Standardization as "the process of developing and agreeing on (by consensus or decision) uniform engineering criteria for products, processes, practices and methods." Standardization improvement promotes the use of industry standards and best practices in military acquisitions. This is sound policy supporting the basic logic behind any standardization effort. If the Military's production runs are no longer significant compared to industry's, then savings can accrue by buying from industry's normal production runs. For example, when both Beta and VHS had roughly equal market share, Navy ships carried Beta tapes for ships crews entertainment. Obviously, to have continued with Beta after VHS became dominant would have been foolish from both a consumer and cost perspective.

The commercial large vessel marine industry is not strong compared to the military side with 66% of the major shipyard sales coming from the military. This means that there are no pre-existing industry NGS consensus standards available that are appropriate for use on naval combatant vessels.

The traditional model for ship acquisition was based upon military specifications, standards, and requirements that were maintained by the government. NAVSEA maintained 4127 military specifications and standards as of 1995. Since then, standards improvement actions have resulted in cancellation of 791 of these documents and inactivation for new design of another 1,029 documents.

These dispositions were based on the documents imposing unnecessary and/or costly requirements and their void being filled by NGSs or performance-based specifications. In general these dispositions have been low risk as the documents were obsolete or there were suitable non-government standards available.

However, subsequent discussions with National Shipbuilding Research Program (NSRP) members and other industry representatives indicate that many of these documents, as well as those pending disposition, may still be needed to respond to Navy requirements.

Navy standardization engineering and management resources have decreased significantly. These include in-house mission funded government employees, task funded government employees, and contractors. As part of the re-alignment and downsizing of the NAVSEA Engineering Directorate, the primary engineering effort of drafting standards is no longer done by mission funded engineers. Additionally, in 1995 the funding for Navy Standardization work came under the cognizance of the Navy Acquisition Reform Office. This office is responsible for standards improvement but not standards maintenance and has therefore eliminated all funding in FY 01 and beyond. The available resources for

Standardization work within NAVSEA have dropped from a high of \$30 million to a current yearly value of \$2 million. Another drop is expected next year.

In addition to developing uniform engineering criteria, standardization should also improve operational readiness, reduce total ownership costs, and reduce cycle time while meeting user needs. Unfortunately, the Navy Standards Improvement Program has fostered the perception by some that standardization per se was increasing our costs. This is not true. The higher costs were due to burdensome requirements and non-consideration of better value industry practices. The mandate of standards improvement has always been to eliminate unnecessary requirements and standardize on a larger universe of products - the commercial market - rather than the small universe of naval products. The intention is to improve the way in which we standardize, so as to achieve the identifiable benefits of standardization, not to eliminate standardization.

NAVSEA's ship systems engineering corporate knowledge resides within the minds of our workforce and the documented knowledge contained in the General Specifications for Ships of the U.S. Navy (GENSPECS), design data sheets, instructions, technical manuals, and military specifications and standards. Our workforce is being downsized and our legacy documents are being subsumed by standardization improvement actions resulting in erosion of this knowledge base. We currently have no mechanism for incorporating and institutionalizing this knowledge as well as lessons learned from prior programs.

The Navy cannot revert to traditional ship acquisition methods and their associated high costs. We also cannot continue with the existing status quo without a proper standardization infrastructure. The SSEP will provide such an infrastructure and will institutionalize corporate knowledge and lessons learned for ship performance-based acquisitions.

## TRADITIONAL SHIP ACQUISITION

Naval ship design up until the early 1990's was led by the government with detailed direction on what the requirements were and how these requirements were to be achieved. Contractor involvement was very limited until a contract design was passed to the shipbuilder for further detailed design and ship construction. This process, illustrated in Figure 1, entailed significant lead times frequently caused by incomplete or changing requirements, complex systems integrations, and cumbersome review/approval processes. Generous cold-war budgets did not encourage innovations in cost reduction or cycle time streamlining.

NAVSEA's corporate knowledge was (and still is) contained in a variety of documents, such as the now canceled GENSPECS, past ship designs, technical manuals, military specifications, and drawings. NAVSEA produced detailed ship specifications, by using highly experienced engineers to draw the desired details from this corporate knowledge base.

Top-level mission requirements were taken as inputs by the Navy design community who usually captured unstated or qualitative operational requirements in the initial ship specification. Other than the ship specification, there was often very little input from the design community to other related acquisition documents such as the Statement of Work (SOW), Instructions to Offerors (Solicitation Section L), and Solicitation Evaluation Criteria (Section M). Systems engineering disciplines such as producibility, logistics support, and other "ilities" were problematic from program to program. Consideration of life cycle total ownership costs was usually subservient to development and production cost considerations. Figure 1 illustrates the traditional ship acquisition process.

Figure 1  
Traditional Ship Acquisition

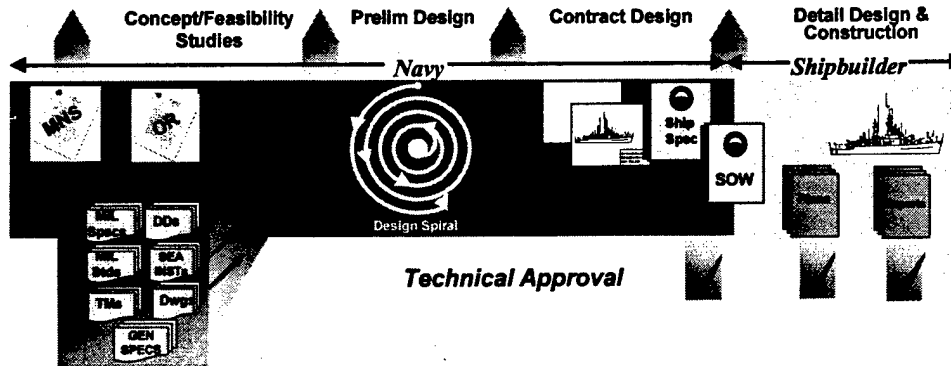

- Technical (MILSPEC) based, risk averse environment
- Lessons learned captured in Navy design
- Over the transom Navy to contractor handoffs

## SHIP ACQUISITION TODAY

On 29 June 1994, the Secretary of Defense (SECDEF) directed sweeping reform in the use of military specifications and standards, with emphasis on greater use of performance-based and commercial requirements in the acquisition process. Subsequent initiatives were directed at government/industry teaming, streamlining the acquisition process, reducing TOC, and increasing use of commercial practices and processes.

Ship Program Managers (SPMs) are implementing various approaches to comply with the standardization reform mandate and associated acquisition reform initiatives. The LPD 17, NSSN, DD 21, and T-ADC(X) procurements, for example, have each implemented different acquisition strategies and innovations. Earlier teaming with the shipbuilder within an IPPD framework is

generally practiced. Approaches vary in the integration and correlation of system requirements within the various acquisition documents.

There is nothing inherently wrong with individual approaches. However, each approach creates its own unique set of issues and associated lessons to be learned. Without a standardized approach we perpetually remain on the steep end of the learning curve; perhaps advancing, but without accumulating an institutionalized knowledge base.

Shipbuilders, vendors, Supervisors of Shipbuilding (SUPSHIPS), and fleet support organizations have also identified varying technical as well as cultural issues in attempting to implement the new performance-based acquisition policies. Figure 2 illustrates the current ship acquisition process.

Figure 2.  
Current Ship Acquisition

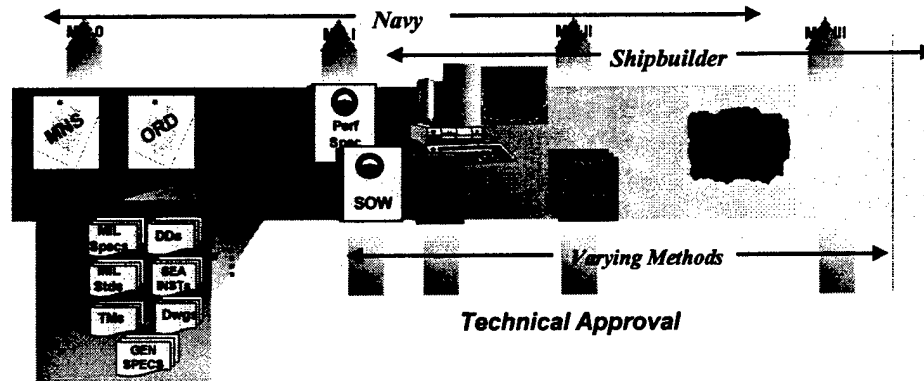

- Performance-based, risk variable environment
- Lessons learned not formally captured
- Varying program approaches and degrees of integration

Though NAVSEA has made significant progress in converting military specifications to performance-based specifications and/or non-government standards, there are still concerns over losing valuable design lessons learned within this process. The GENSPECS, the traditional shipbuilding design baseline, was canceled in 1999. Some military specification/GENSPECS design practices satisfy unique military requirements and cannot be replaced with a commercial equivalent. Many shipbuilders and vendors are uncomfortable with the performance-based environment. The ultimate issue is the potential loss of design lessons learned inherent within the GENSPECS and military specifications and standards as we implement performance-based procurements. Also of concern is the Navy's retention of appropriate technical approval at critical ship design, test, and acceptance milestones.

SEA 05Q discussions with the PEO/NAVSEA workforce as well as results of AR Week workforce surveys indicate a desire for better practical systems engineering tools. Heller (1996) describes how the SC-21 program

desired better tools to make decisions based on life cycle implications and risk management considerations. During a 1997 ASNE luncheon, SEAWOLF program representatives cited systems engineering as a serial vice an integrated process as a program lesson learned. The industry led Coopers and Lybrand Study (1997) identifies inadequate performance-based procurements and requirements definition as two acquisition issues. Tired of "buzzwords", our shrinking workforce wants better guidance and tools to help them continue to acquire world-class products within the new business environment.

## SYSTEMS ENGINEERING PROCESS

OUSDA&T) is sponsoring a Capability Maturity Model (CMM) integration product suite to provide industry and government a set of integrated products to support process and product improvement. The Systems Engineering CMM, a subset of this product suite, defines systems engineering as the selective application of scientific and engineering efforts to:

- Transform an operational need into a description of the system configuration which best satisfies the operational need according to the measures of effectiveness;
- Integrate related technical parameters and ensure compatibility of all physical, functional, and technical program interfaces in a manner which optimizes the total system definition and design;
- Integrate the efforts of all engineering disciplines and specialties into the total engineering effort

In the spirit of the above definition, the Navy needs to adapt its systems engineering process to better accommodate commercial practices and link the various ship/system design elements in a logical fashion within the total ship acquisition process. These are the objectives of the SSEP.

The formal systems engineering process as defined by EIA Standard IS-632 and as taught at the Defense Systems Management College (DSMC ) demands a requirement input and a design output. Figure 3 shows this process for ship engineering. Needs are defined within the Mission Needs Statement (MNS) and are further refined into the Operational Requirements Document (ORD). The ORD represents the definition of the problem that

must be solved by the process. At the other end of the process is the final design or the build-to-print.

The A-Specification or system performance specification defines required capabilities at the system level using performance terminology. Performance terminology uses verbs to define requirements as opposed to nouns. For example, a performance requirement might be, "The ship shall be capable of transiting at a sustained speed of 30 knots." The B-Specification or allocated specification continues to use performance terminology, but allocates requirements to the subsystem level. For example, an allocated requirement derived from the A-specification might be, "The main propulsor shall produce 50,000 SHP." The C-Specification, also known as the detailed specification, defines down to components in terms of nouns. For example, "The main propulsor shall consist of two LM 2500 Gas Turbines." No single approach is inherently required to implement the systems engineering process.

The ship systems engineering process entails requirements defined by the government with the product defined by the contractor. Smooth transition from the government to the contractor within this process is extremely difficult. Government contracting dictates that requirements imposed upon the contractor must

### Figure 3. Systems Engineering Process

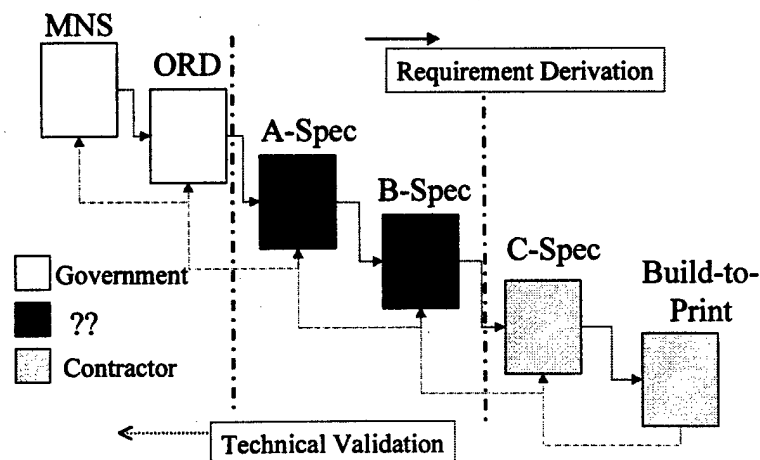

be quantifiable and verifiable in order to ensure that the product received is appropriate for its intended use. Figure 4 illustrates a simplified view of the contracting process.

authority on these deliverables depending upon contract provisions. The contracting process must include appropriate design/engineering reviews and decision points to ensure acceptability of the delivered products.

Figure 4. Simplified Contracting Model

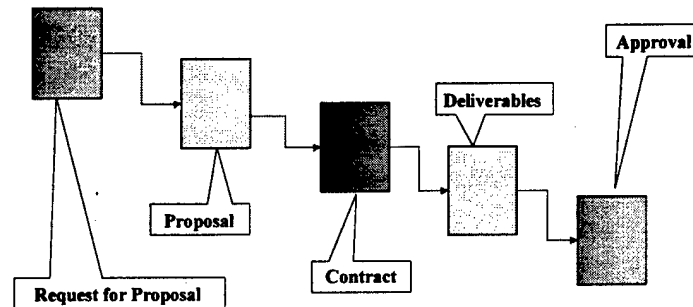

The contracting process starts with a Request for Proposal (RFP) developed by the government. Two sections of the RFP that are particularly critical are Sections L and M. Section L, Instructions to Offerors, summarizes key items to be brought to the attention of offerors, identifies special requirements beyond the statement of work and specification, and identifies proposal submission requirements. Section M defines the mechanism that the government will use to evaluate those proposals. These two sections, very important in the evaluation and award process, require coordinated input from the Navy engineering community.

Once the bidders have submitted their proposals and the winning bidder has been selected, the contract is signed. The contract is usually some combination of the RFP and the winning proposal. As the contract terms are executed, the contractor delivers products to the government as required by the contract. The government might or might not have approval

## SHIP SYSTEMS ENGINEERING GUIDING PRINCIPLES

The following are the guiding principles behind the SSEP:

- Provide a practical tool-set for performance-based ship acquisitions
- Capture and document valuable ship-design lessons learned
- Facilitate operational and technical requirements development, traceability, and verification
- Clarify appropriate ship design evaluations and verifications
- Reduce ship acquisition cycle times and Total Ownership Costs

The underlying objective of these principles is to enable the definition of best-value ship technical requirements and then to find the right home for these requirements in the various acquisition documents. Three tools are under development.

The Total Ship Performance Specification (TSPS) provides a template for developing ship performance-based specifications. American Bureau of Shipping (ABS) Naval Vessel Rules (NVRs) use proven commercial practices in the design and classification of designated naval ships and ship systems. The Ship Systems Engineering Baseline (SSEB) provides best practice guidance for developing related functional requirements and acquisition documentation. A Ship Systems Engineering Integrated Product Team (SSEIPT), chaired by NAVSEA 05Q is guiding the SSEB roadmap.

## **SHIP SYSTEMS ENGINEERING PRODUCTS**

### **Total Ship Performance Specification (TSPS)**

The TSPS provides guidance for translation of warfighter-focused operational requirements into ship performance-based specifications. The TSPS is a streamlined successor to the canceled GENSPECs. The TSPS structure, modeled on MIL-STD-961D, emphasizes:

- Total ship and ship-system performance;
- Operational profile(s) and environment;
- Interface requirements; and
- Verification methods

The TSPS focuses ship specification contents to the minimum necessary functions and performance requirements and accommodates tailoring for specific program needs. The emphasis is on total ship requirements including coverage of manning, supportability and statutory/regulatory requirements. The verification section (section 4) of the TSPS specifies the requirements for demonstrating compliance with section 3 performance requirements. Each sub-section of the requirements section will have a corresponding verification sub-section. Verification methods will correlate to appropriate ABS NVRs and other Navy criteria and may include analysis, modeling, tests, trials, and certifications.

The TSPS will be comprehensive in addressing appropriate interface and life cycle support criteria that may have not been thoroughly addressed in traditional ship specifications. The NAVSEA Best Value Logistics Directorate (SEA 04L2), a member of the SSEIPT, is identifying TSPS supportability criteria that supports Defense Reform logistic initiatives.

By providing a comprehensive performance-based template for all naval ships, the TSPS will provide a starting baseline for future ship acquisitions while accommodating program peculiar needs.

### **ABS Naval Vessel Rules**

The American Bureau of Shipping (ABS), an international leader in ship classifications, has developed Rules for the design, construction, and classification of marine vessels and structures. These Rules have evolved and been approved by technical committees with subject matter expert representation from shipyards, ship owners, ship operators, design activities academia, government agencies, and regulatory bodies. Under cooperative agreement with NAVSEA, ABS is currently developing NVRs for selected Navy ships and ship systems which builds upon established ABS Rules supplemented by those requirements necessary to address unique Navy applications.

The US Coast Guard (USCG), Military Sealift Command (MSC), and Maritime Administration (MARAD) have already demonstrated effective government use of ABS Rules and classification criteria proven by the commercial marine industry. The ABS NVRs, non-government standards (NGSs) and essential military specifications/standards that have no commercial equivalent will anchor the SSEB certification criteria. These criteria will form the baseline for certification of system design integrity, fitness for intended service, and compliance with specification requirements.

Envisioned certification criteria will be arranged in matrix format correlating to the Extended Ship Work Breakdown Structure (ESWBS). This facilitates cross-referencing to previous Navy programs and for compatibility with established shipbuilding practices. NVRs and NGSs will be priority criteria. Essential military requirements not covered by these sources will be covered in performance specifications, retained MILSPECS, or NGS supplements. This will include information captured from GENSPECS, Design Data Sheets (DDS) and other technical information.

A sample criteria matrix for Group 100 Hull Structure, modeled after the Arsenal Ship program, is shown in Table 1.

### **Ship Systems Engineering Baseline**

The Ship Systems Engineering Baseline (SSEB) will correlate with the TSPS, NVRs, and certification criteria in guiding development of other related acquisition documentation. This includes the SOW, Sections L&M, and other contractual provisions. The SSEB will allow visibility of the impact of ship engineering decisions within the total acquisition process. SSEB content will include best practice guidance in developing criteria for life cycle support, TOC, Integrated Product Data Environments (IPDE), and other related ship systems engineering disciplines.

The SSEB will borrow from other available sources such as ASN(RD&A)s TURBO Streamliner and MIL-HDBK-245 in providing SOW and Statement of Objectives (SOO) guidance. The SSEB will improve upon these tools in providing guidance specifically for ship acquisition. Guidance for Section L, Instructions to Offerors, will be especially critical in communicating evaluation criteria considerations for critical functions such as risk management and TOC. Figure 5 illustrates the interaction of the SSEB documents with the contract structure.

### **Requirements Tracing**

Both industry and the NAVSEA workforce have identified unclear operational/technical requirements as an acquisition issue. Requirement traceability and correlation is especially important for complex ship design acquisitions. Content of the SSEB's three products will be correlated by a requirement tracing tool set. The tracing tool set will have two applications. It will enable linkage of derived requirements with higher level documents (ORD e.g.) allowing clear communicating and interpretation of requirements in accordance with Standardization Document (SD) -16, Communicating Requirements. It will also map relevant NAVSEA corporate knowledge from canceled or inactive military specifications, the GENSPECS and other design data sources and will link the use of NVRs and other design best practices. Figure 6 illustrates the capturing of lessons learned and best practices within the SSEB framework.

### **SSEP PROCESS**

The SSEB process includes other supporting activities in addition to product development. NAVSEA 05 is continuing the review and disposition of military specifications and standards under the Standardization Improvement Program. The goal is to replace or convert as many of these requirements as possible to performance-based specifications and/or NGSs. Many of the cancelled military documents have equivalent NGSs. The SSEB is leveraging from the NAVSEA technical community's coordination with NGS organizations in defining specifications and standards supporting the NVRs. Approximately 800 NGSs have been identified as part of the NVR and certification family. This effort has the added benefit of the Navy design community becoming more familiar with the commercial shipbuilding marketplace as well as with commercial standards.

**Table 1. Sample Matrix Group 100 - Hull Structure\***

Index	System	Topic	Standard	Certification		Comment
				Type	Agent	
100	Structures	Structural Design Criteria report	ABS Rules Part 3, Sections 1,2,4 to 19, 21 & 23/ Navy 100 Series Design Data Sheets	Class	ABS	Includes Weapon effects considerations for UNDEX, AIREX, shock, etc.
		Longitudinal Strength Study	ABS Rules 3/6 / DDS 100-6	Class	ABS	
		Hull Whipping Analysis	Navy	Comply	ABS	
		Scantling Calculations	ABS Rules 3/4 through 3/20, 3/C, 3/D	Class	ABS	
		Fatigue Analysis	ABS Rules (Special Consideration)	Class	ABS	
		Midship Section Drawing	ABS Rules 3/6 through 3/20, 2/23	Class	ABS	
		Structural Details	ABS Rules 3/2.11	Class	ABS	
		Scantling Profile	ABS Rules 3/6 through 3/20, 3/23, 3/C	Class	ABS	
		Shell Expansion	ABS Rules 3/15	Class	ABS	
		Structural Stanchions	ABS Rules 3/11.3	Class	ABS	
		Hull Framing	ABS Rules 3/7, 3/8, 3/9	Class	ABS	
		Structural Bulkheads	ABS Rules 3/12, 3/13	Class	ABS	
		Decks and Platforms	ABS Rules 3/10-11, 3/16, 3/17, 11	Class	ABS	DDS 130-2 applies for helicopter landing deck
		Superstructure	ABS Rules 3/17	Class	ABS	DDS 100-7 may apply
Masts	DDS 170-0	Comply	ABS			

\* From Arntson, S. *et al.*, *Arsenal Ship Program Certification Plan*, Naval Engineers Journal, January 1998, pp. 256.

Figure 5. SSEP Document Relationship to Contract

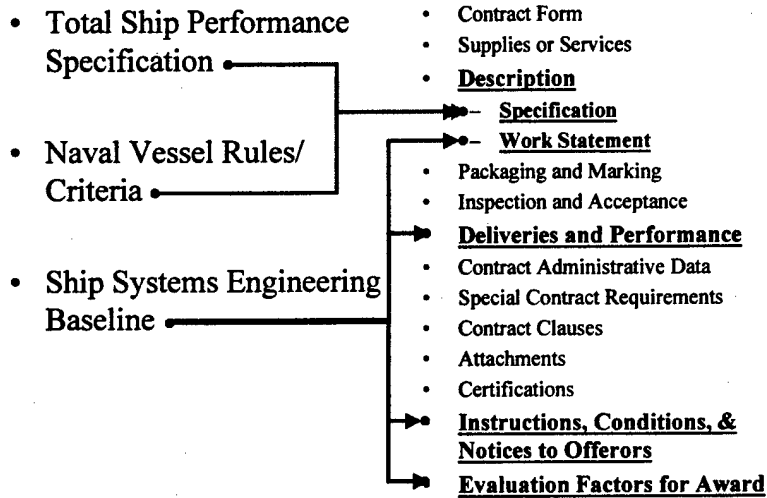
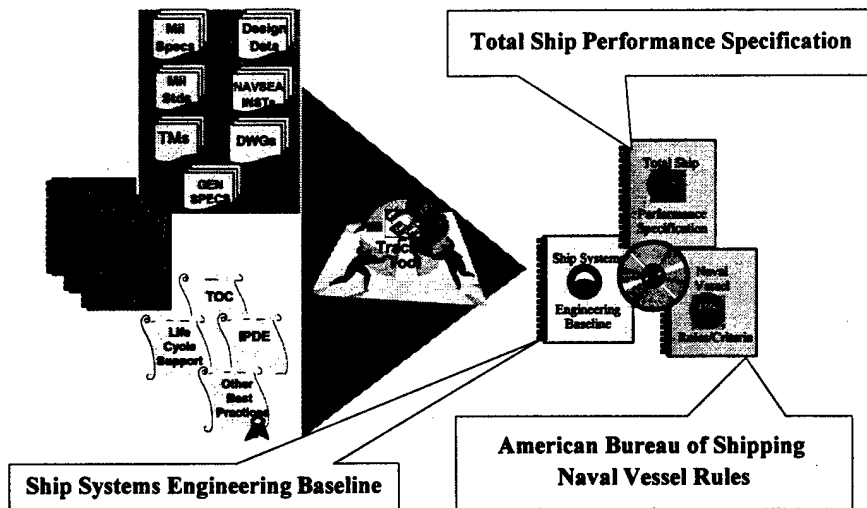

Figure 6. Capturing Best Practices & Lessons Learned



Bergner, et.al. (1996) and subsequent studies highlight the significantly lower costs and cycle times of commercial ship acquisition practices and recommend Navy adoption of similar processes. Bergner, et.al. (1996) have found a typical average commercial ship acquisition cycle (inquiry to contract signature) to be 13 to 20 weeks. This is due to world scale competition, performance-based procurements, and established business relationships between owners and shipbuilders. The SSEIPT is investigating global ship acquisition processes (commercial and military) to identify best-practice methods that may be applied to U.S. Navy ship acquisition. This includes investigation of both domestic and foreign procurement/build methods for various ships including tankers, containerships, RO/RO, bulk carriers, cruise ships, etc. Acquisition methods of other DoD agencies, the USCG, the offshore oil industry, and the aerospace industry will also be assessed.

The SSEP has many stakeholders with the Fleet being the ultimate beneficiary. NAVSEA 05Q continues to brief PEOs, SPMs, Supervisors of Shipbuilding, and NSRP industry members in soliciting participation in the SSEP. Figure 7 illustrates the complete SSEP roadmap.

## ENVISIONED SHIP ACQUISITION

Using the SSEP knowledge-based products, future ship acquisitions will be accomplished within an institutionalized systems engineered process. The TSPS will assist in transforming operational needs from the MNS/ORD to performance-based ship system requirements for any ship class or configuration. The integration and compatibility of technical parameters and interfaces will be accomplished through the judicious criteria-based selection of NVRs, NGSs, commercial practices, Navy unique requirements and appropriate technical approval checkpoints. The SSEB will facilitate the definition and integration of related engineering discipline requirements within the RFP and contract structure. The SSEB will also allow selection of innovative or special contract provisions to foster reduced cycle times and contractor innovation. SPMs will be able to track requirements as they evolve within the product hierarchy as well as to link to knowledge and lessons learned from canceled or inactive military specifications and prior ship acquisition programs. Figure 8 illustrates the envisioned ship acquisition process.

Figure 7. Roadmap

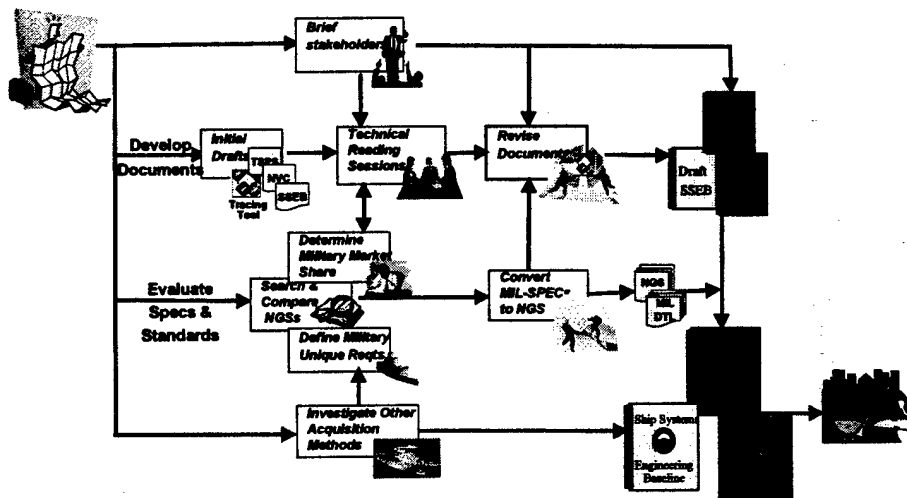
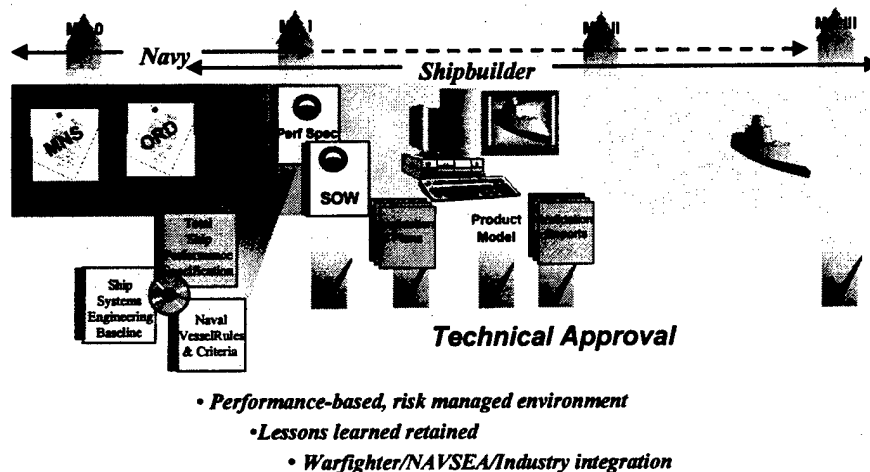

Figure 8.  
Envisioned Ship Acquisition



## CONCLUSION

Traditional ship systems engineering, in a compartmented government/industry environment, has successfully delivered best-in-class ships but usually at significant cost and cycle times with sometimes scant consideration of related disciplines and specialties. The recent AR driven ship acquisitions have focused on Navy/industry teaming to identify innovations within a performance-based environment; but the levels of integration are mixed, and the results are to be determined in achieving optimized total system solutions. The SSEP aims to achieve all of the Systems Engineering CMM objectives by providing a practical tool-set that focuses on operational needs and integrates all technical and functional interfaces in providing future world-class Navy ships.

## REFERENCES

Arntson, S. et al., "Arsenal Ship Program Certification Plan", Naval Engineers Journal, January 1998.

Bergner, Melsom, Safina, and Staiman, "Commercializing the Navy Ship Acquisition Process", Association of Scientists and Engineers Technical Symposium, April 1996

Coopers & Lybrand Report, "Acquisition Reform Implementation an Industry Survey", October 1997

DoD 4120.3-M Defense Standardization Program (DSP) Policies & Procedures, July 1993

Electronic Industries Association Interim Standard, Systems Engineering Capability Maturity Model, EIA/IS 731, 1996

Heller, James L., "The SC-21 Program" Association of Scientists and Engineers Technical Symposium, April 1996.

MIL-STD-961D, Defense Specification Practices, March 1995

Standardization Document (SD) -16, Communicating Requirements, November 1998

## BIOGRAPHIES

Mr. David White, the principal author, is the Command Standards Executive (CSE) for the Naval Sea Systems Command, serving in that role since 1998. He graduated from the University of Michigan in 1982 with a BSE in Naval Architecture and Marine Engineering. Upon graduation, Mr. White was commissioned as an officer in the U.S. Navy and served on board the USS McCloy (FF-1038). In 1987, He joined the Naval Sea Systems Command as a Naval Architect in the Hull Form and Hydrodynamics Division. In 1991, Mr. White accepted a position with the Advanced Amphibious Assault Direct Reporting Program Manager's Office (DRPM AAA) where he served as the Survivability Division Head. He received a Masters in Systems and Industrial Engineering from Virginia Tech in 1992 and has completed the Defense Systems Management College (DSMC) Program Manager's Course. He is currently enrolled in the Defense Leadership and Management (DLAMP) program. Mr. White is married to the former Robin Lee Parker, who is the NAVSEA Division Head for Weights and Stability. They have two children, Gordon (age 14) and Leah (age 11).

James A. Hill is a Senior Project Engineer with M. Rosenblatt and Son Inc. in Arlington Virginia. He received a BA degree in Economics from the University of Nebraska in 1972 and his MS degree in Mechanical Engineering from the Naval Postgraduate School in 1979. Before joining Rosenblatt in 1993, he spent 21 years in the Navy where he gained both operating and maintenance experience in the fleet, and design experience at NAVSEA. He currently supervises the engineering efforts associated with Mil-Spec revisions and document maintenance--developing auditable processes, reviewing standardization decisions, converting detailed specifications to performance based documents, and ensuring conformance with acquisition reform principles. He is a member of the National Fire Protection Association (NFPA) and the Society of Naval Architects and Marine Engineers (SNAME),

with membership on technical panels in both organizations.

Thomas F. Copsey is a Senior Staff Specialist with Columbia Research Corporation in Arlington Virginia. He received a BS degree in Aerospace Engineering from the University of Maryland and a Masters in Engineering Administration degree from the George Washington University. Mr. Copsey joined Columbia Research Corporation in 1974 and has managed both Navy surface and undersea warfare acquisition support projects. He has recently participated on the NAVSEA Acquisition Reform Forum and the Contractor Performance Assessment Reporting System (CPARS) Automation Team. As a member of the NAVSEA Ship Systems Engineering Integrated Product Team, he is currently assessing global ship acquisition methods to identify best practices that may be applied to U.S. Navy ship acquisitions. Mr. Copsey is a member of the National Defense Industrial Association (NDIA).