

JPRS 71659

10 August 1978

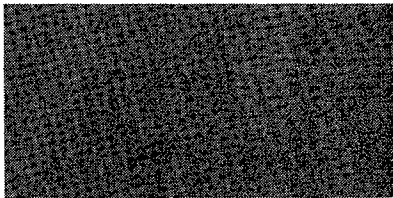

U S S R

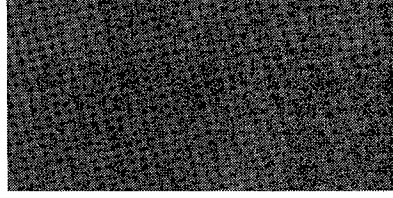
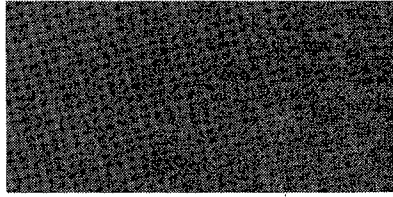

TRANSLATIONS ON USSR SCIENCE AND TECHNOLOGY
PHYSICAL SCIENCES AND TECHNOLOGY

No. 44

DISTRIBUTION STATEMENT A
Approved for Public Release
Distribution Unlimited

20000501 069

Reproduced From
Best Available Copy

U. S. JOINT PUBLICATIONS RESEARCH SERVICE

REPRODUCED BY
**NATIONAL TECHNICAL
INFORMATION SERVICE**
U. S. DEPARTMENT OF COMMERCE
SPRINGFIELD, VA. 22161

NOTE

JPRS publications contain information primarily from foreign newspapers, periodicals and books, but also from news agency transmissions and broadcasts. Materials from foreign-language sources are translated; those from English-language sources are transcribed or reprinted, with the original phrasing and other characteristics retained.

Headlines, editorial reports, and material enclosed in brackets [] are supplied by JPRS. Processing indicators such as [Text] or [Excerpt] in the first line of each item, or following the last line of a brief, indicate how the original information was processed. Where no processing indicator is given, the information was summarized or extracted.

Unfamiliar names rendered phonetically or transliterated are enclosed in parentheses. Words or names preceded by a question mark and enclosed in parentheses were not clear in the original but have been supplied as appropriate in context. Other unattributed parenthetical notes within the body of an item originate with the source. Times within items are as given by source.

The contents of this publication in no way represent the policies, views or attitudes of the U.S. Government.

PROCUREMENT OF PUBLICATIONS

JPRS publications may be ordered from the National Technical Information Service (NTIS), Springfield, Virginia 22151. In ordering, it is recommended that the JPRS number, title, date and author, if applicable, of publication be cited.

Current JPRS publications are announced in Government Reports Announcements issued semimonthly by the NTIS, and are listed in the Monthly Catalog of U.S. Government Publications issued by the Superintendent of Documents, U.S. Government Printing Office, Washington, D.C. 20402.

Indexes to this report (by keyword, author, personal names, title and series) are available through Bell & Howell, Old Mansfield Road, Wooster, Ohio, 44691.

Correspondence pertaining to matters other than procurement may be addressed to Joint Publications Research Service, 1000 North Glebe Road, Arlington, Virginia 22201.

Soviet journal articles displaying a copyright notice and included in this report are reproduced and sold by NTIS with permission of the copyright agency of the Soviet Union. Further reproduction of these copyrighted journal articles is prohibited without permission from the copyright agency of the Soviet Union.

BIBLIOGRAPHIC DATA SHEET		1. Report No. JPRS 71659	2.	3. Recipient's Accession No.
4. Title and Subtitle TRANSLATIONS ON USSR SCIENCE AND TECHNOLOGY - PHYSICAL SCIENCES AND TECHNOLOGY No. 44		5. Report Date 10 August 1978		6.
7. Author(s)		8. Performing Organization Rept. No.		
9. Performing Organization Name and Address Joint Publications Research Service 1000 North Glebe Road Arlington, Virginia 22201		10. Project/Task/Work Unit No.		11. Contract/Grant No.
12. Sponsoring Organization Name and Address As above		13. Type of Report & Period Covered		14.
15. Supplementary Notes				
16. Abstracts The report contains information on aeronautics; astronomy and astrophysics; atmospheric sciences; chemistry; earth sciences and oceanography; electronics and electrical engineering; energy conversion; materials; mathematical sciences; cybernetics, computers; mechanical, industrial, civil, and marine engineering; methods and equipment; missile technology; navigation, communications, detection, and countermeasures, nuclear science and technology; ordnance; physics; propulsion and fuels; space technology; and scientists and scientific organization in the physical sciences.				
17. Key Words and Document Analysis.		17a. Descriptors		
USSR		Electronics	Missile Technology	
Aeronautics		Electrical Engineering	Navigation and	
Astronomy		Energy Conversion	Communications	
Astrophysics		Materials	Detection and	
Atmospheric Sciences		Mathematics	Countermeasures	
Chemistry		Mechanical Engineering	Nuclear Science and	
Computers		Civil Engineering	Technology	
Cybernetics		Industrial Engineering	Ordnance	
Earth Sciences		Marine Engineering	Physics	
Oceanography		Methods	Propulsion and Fuels	
17b. Identifiers/Open-Ended Terms		Equipment	Space Technology	
17c. COSATI Field/Group 01,03,04,07,08,09,10,11,12,13,14,16,17,18,19,20,21,22				
18. Availability Statement Unlimited Availability Sold by NTIS Springfield, Virginia 22151		19. Security Class (This Report) UNCLASSIFIED	21. No. of Pages 92	
		20. Security Class (This Page) UNCLASSIFIED	22. Price Per page 5	

TRANSLATIONS ON USSR SCIENCE AND TECHNOLOGY
 PHYSICAL SCIENCES AND TECHNOLOGY

No. 44

CONTENTS

PAGE

CYBERNETICS, COMPUTERS AND AUTOMATION TECHNOLOGY

General-Purpose Interpreting System for Editing and Translating Programs for Standard-Unit Computer Hardware System (ASVT) M-6000 Computers (V.N. Krekov, et al.; PRIBORY I SISTEMY UPRAVLENIYA, No 5, 1978)	1
Problems in Creation of an Automated Debugging System for the M-7000 Processor (F.F. Buchakchiyskiy, et al.; PRIBORY I SISTEMY UPRAVLENIYA, No 5, 1978)	9
Il'ichevsk Transportation Center Works on Continuous Schedule-Plan (Ye Krushkin; VODNYY TRANSPORT, 6 Jun 78)	17
Plans for Automation in the Ukraine (V.P. Shevchenko; MEKHANIZATSIYA I AVTOMATIZATSIYA UPRAVLENIYA, Jan-Mar 78)	23
Serious Problems in Coordinating Development of Rechflot ASU (V. Nevolin; RECHNOY TRANSPORT, No 1, 1978)	31

SCIENTISTS AND SCIENTIFIC ORGANIZATIONS

New Members of Latvian SSR Academy of Sciences Presented (NAUKA I TEKHNIKA, Jun 78)	36
Digital Electronic Metrology Expert V.M. Shlyandin Hailed (PRIBORY I SISTEMY UPRAVLENIYA, No 5, 1978)	44
Scientific Instrument Making Product Identification Approach Discussed (A.P. Pakhomov; PRIBORY I SISTEMY UPRAVLENIYA, No 5, 1978) .	46

CONTENTS (Continued)

Page

Production of Experimental Models of Complex Instruments Improved (D.F. Guz', et al.; PRIBORY I SISTEMY UPRAVLENIYA, No 5, 1978)	50
Measuring and Information Systems Conference, Baku 1977, Reviewed (PRIBORY I SISTEMY UPRAVLENIYA, No 5, 1978)	54
Vitebsk Electronic Measuring Equipment Plant Conference Topics Discussed (V.A. Ivanova; PRIBORY I SISTEMY UPRAVLENIYA, No 5, 1978)..	61
Yaroslavl' Technological Design and Scientific Research Institute Conference (V.V. Risunov; PRIBORY I SISTEMY UPRAVLENIYA, No 5, 1978)..	68

PUBLICATIONS

New Books, Content Summarized (PRIBORY I SISTEMY UPRAVLENIYA, No 5, 1978)	71
Brief Abstracts of Library Accessions and Book Review (MEKHANIZATSIYA I AVTOMATIZATSIYA UPRAVLENIYA, Jan-Mar 1978)	77
Brief Abstracts of Articles in 'MEKHANIZATSIYA I AVTOMATIZATSIYA UPRAVLENIYA' (MEKHANIZATSIYA I AVTOMATIZATSIYA UPRAVLENIYA, Jan-Mar 1978)	82

UDC 681.326

GENERAL-PURPOSE INTERPRETING SYSTEM FOR EDITING AND TRANSLATING PROGRAMS FOR
STANDARD-UNIT COMPUTER HARDWARE SYSTEM (ASVT) M-6000 COMPUTERS

Moscow PRIBORY I SISTEMY UPRAVLENIYA in Russian No 5, 1978 pp 7-9

[Article by V.N. Krekov, A.N. Tsygankov and A.I. Udod, engineers]

[Text] At the VTs [computing center] of the TsPKB [Central Planning and Design Bureau] for Systems for Automating Production (Moscow) in 1976 was developed and put into service a general-purpose interpreting system (UIS), representing the development of an absolute system for editing and translation supplied by the Impul's NPO [Scientific Production Association] (Severodonetsk) as standard software.

The main purpose of this UIS is, while totally maintaining the essence of editing and translation, as well as the combination of existing programs for performing these operations, to alter their technological process for purposes of drastically improving the productivity of the computer and programmer (especially where there is no alphanumeric printer, no ATsPU), of creating maximum convenience for the programmer when working with the computer, of eliminating nonproductive losses of paper and machine time for preparatory operations, of reducing the number of system media, and of extending the operating resources of input-output (I/O) units.

The system is simple and reliable in operation, has highly advanced functional capabilities, goes together easily with a large number of absolute routines (editors, translators, etc.), and adapts well, i.e., makes it possible, without any rearrangements, to select any I/O unit, type of punched tape (PL) for input and output, and any editing and translating mode, including any standard mode included in the system by the developer (the Impul's NPO).

Objective Preconditions for Development of the UIS

As we know, translators and editors created for M-6000 computers are not designed to control peripherals, and to organize I/O information when these programs are being run it is necessary to use I/O drivers. Furthermore, each of these programs can be run simultaneously only with three drivers (printing, punched tape input, and PL output drivers). If it is taken into

account that it is always necessary to make alternate use of five and eight-track tapes, and that the majority of computers contain two printers, the need becomes obvious for eight I/O systems with three drivers in each. Now if it is kept in mind that a translator and editor must be debugged for each specific set of drivers, causing the addition of 16 more program variants (eight each for the translator and editor), the unwieldiness of the system as a whole becomes clear.

In addition, employment of this system involves heavy losses of machine time (overloading in the process of operation, using a new PL combination, etc.).

And, finally, the main point. If the computer's combination has no wide-scale printer (ATsPU), then the efficiency of the computer in editing and translating programs is inadmissibly low, since it is determined by the speed of the printers (seven to 10 characters per second). In essence, the processor, operating in pace with the printer and having its own level of rapid response, is all the time at a halt (waiting for the end of character input or output). In translating and editing programs also inevitable are heavy nonproductive losses of machine time for repeating printing operations and obtaining PL because of malfunctions in peripherals and breaks in PL, as well as excessive expenditure of paper and machine time caused by the impossibility, if necessary, of repeating the printout from a specific page or from a specific line of a page.

These disadvantages, which make the existing system inflexible, poorly adaptable, and poorly efficient, are one of the reasons for the too high cost of software being developed.

Principles of Organization of the UIS and Its Functions

With respect to the nature of the functions performed, the UIS can be considered an organizer, since it does not perform the functions of editing and translating per se, but only sets modes of translation, organizes dynamic rearrangement of programs, selects the necessary drivers, imposes lockouts, etc. The UIS's property of controlling the entire process of editing and translation is made possible in the following way: The direct link is broken between the translator and I/O drivers (or between the editor and drivers or between any other absolute routine and drivers), and included in this gap is a supervisor--the system's interpreter. With employment of the UIS all addresses of the translator or editor to the drivers are addressed to the supervisor by means of coupling cells 101-104, and the supervisor, analyzing the interrogated operation, interprets it in keeping with the operator's instructions, at the same time performing all rearrangements of the system (cf. fig 1).

All supervisory functions of the system (choice of I/O unit, type of PL, editing and translating modes, etc.) are set by the operator at the beginning of the run in the form of instructions from the key register of the engineer's console. The choice of printer and type of PL can be made in the process of operation by hitting or resetting the proper keys.

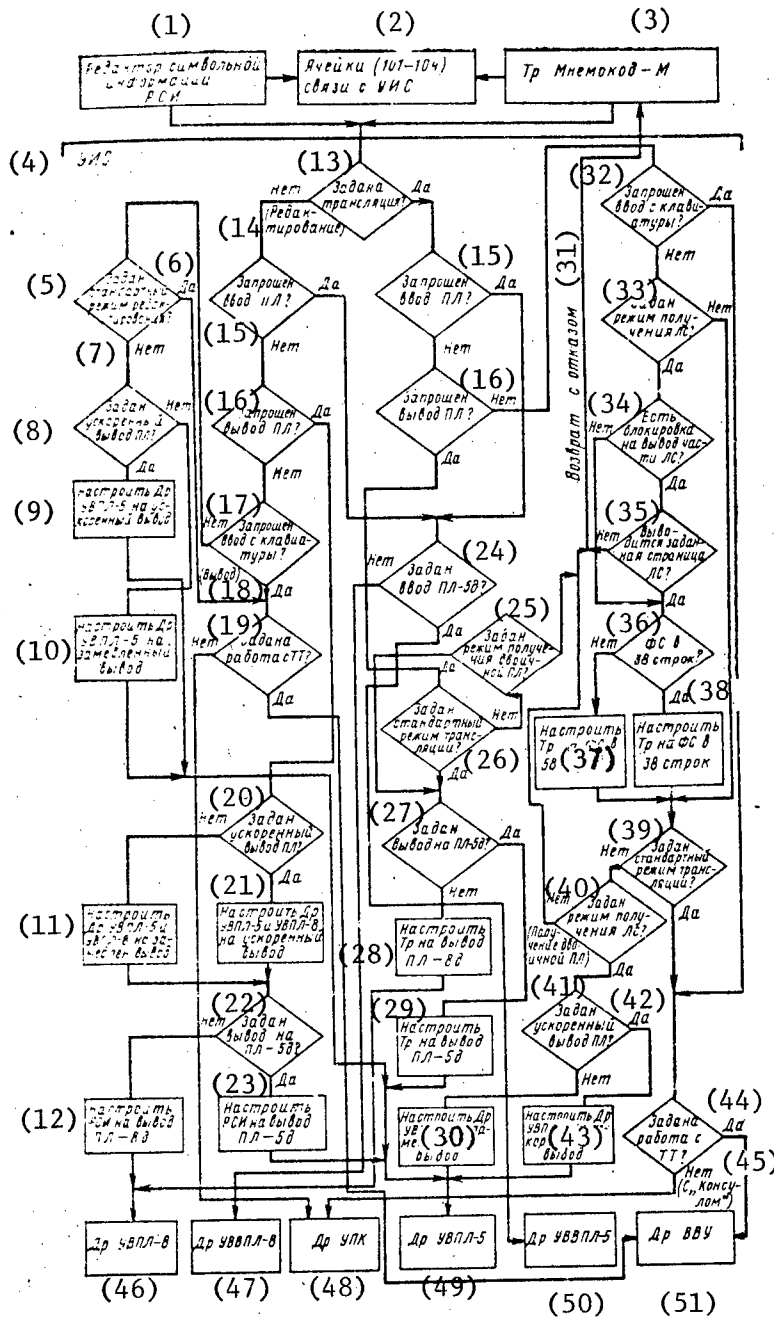

Figure 1. UIS Flowchart: Tr--translator; Dr--driver; TT--teletype; PL-5d and PL-8d--five- and eight-track PL, respectively; Ls--listing; FS--page format

[Key on following page]

Key:

1. Editor of symbolic information, RSI
2. Cells (101-104) for coupling with UIS
3. Tr, "Mnemokod-M"
4. UIS
5. Standard editing mode set?
6. Yes
7. No
8. Speed PL output set?
9. Adjust UVPL-5 driver for speed output
10. Adjust UVPL-5 driver for delayed output
11. Adjust UVPL-5 and UVPL-8 drivers for delayed output
12. Adjust RSI for output of PL-8d
13. Translation set?
14. Editing
15. PL input enabled?
16. PL output enabled?
17. Keyboard entry enabled?
18. Output
19. Operation with TT set?
20. Speed PL output set?
21. Adjust UVPL-5 and UVPL-8 drivers for speed output
22. Output for PL-5d set?
23. Adjust RSI for output of PL-5d
24. PL-5d input set?
25. Mode for obtaining binary PL set?
26. Standard translation mode set?
27. Output for PL-5d set?
28. Adjust Tr for output of PL-8d
29. Adjust Tr for output of PL-5d
30. Adjust UVPL-5 driver for delayed output
31. Rejection and return
32. Keyboard entry enabled?
33. Mode for obtaining listing set?
34. Lockout for output of part of Ls?
35. Specified Ls page read out?
36. 38-line page format?
37. Adjust Tr for 58-line FS
38. Adjust Tr for 38-line FS
39. Standard translation mode set?
40. Mode for obtaining Ls set?
41. Obtaining binary PL
42. Speed PL output set?
43. Set UVPL-5 driver for speed output
44. Operation with TT set?
45. With "Console"
46. UVPL-8 driver
47. UVPL-8 driver
48. UPK driver
49. UVPL-5 driver
50. UVPL-5 driver
51. VVU driver

The configuration of translators, editors and other absolute programs in accordance with the type of PL, length of the printed page of the listing, and the page's line length is performed by the system automatically in keeping with the operator's instructions, which are set on the keyboard register (the register's keys are distributed so that keys operated previously keep their functions).

The system is in the form of a monolithic software package made up of 10 modules, five of which are the following standard I/O drivers: I/O unit (VVU), printing and keyboard entry unit (UPK), five-track PL input (UVVPL-5), 5-track PL output (UVPL-5), and 8-track PL output (UVPL-8).

The system is supplied with the following original software: supervisor-interpreter; driver (UVPL-8); software for dynamic configuration of the "Mnemokod-M" translator; general-purpose software for memory readout (UPVP); software for entry of absolute loader.

The system occupies two pages of memory (for 16K-capacity main memory, cells 34000g-37677g). Minimum capacity of memory for operation with the UIS, 8K.

Configuration of the UIS

The configuration of the UIS starts with the configuration of drivers in the following sequence: VVU driver, UVVPL-5 driver, UVPL-5 driver, UPK driver, UVVPL-8 driver, and UVPL-8 driver. The method of configuration of drivers remains as before. Unit access codes are assigned for the computer complex in which the UIS will be used.

Then programs are loaded in the following sequence: program for loading the absolute loader; program for dynamic configuration of the translator, the system's supervisor-interpreter, and the UPVP program. These programs are not subject to configuration. When the UPVP is loaded into cell 106 an automatic record is made of the address of the last free memory cell.

To obtain the working PL for the UIS, use is made of the UVPV program contained in the UIS. But it is preferable and more convenient to have united working PL's; for example, the "Mnemokod-M" translator plus the UIS or the editor plus the UIS, etc. A united working PL is obtained by means of the UPVP program.

The makeup of peripherals (and of drivers for them) can be altered in configuration of the system, for example, when hooking up the ATsPU.

To locate the system in another area of the memory it is necessary to carry out the appropriate editing for all the programs enumerated, with subsequent configuration of the system.

Functions of the UIS

1. Selection of printer drivers
2. Selection of PL input drivers
3. Selection of PL output drivers
4. Configuration of the translator and editor for operation with a teletype or "Konsul" typewriter
5. Configuration of the translator or editor for operation with five- or eight-track PL input drivers
6. Configuration of the translator or editor for operation with five- or eight-track PL output drivers
7. Increasing or retarding the rate of PL output
8. Permitting readout to print messages regarding errors in translation and lockout (when desired by the operator) of binary PL output

9. Permitting obtainment of binary PL without changing the control operator, with lockout of listing printout
10. Permitting printout of program listing from the page set by the operator, while suppressing printout of all preceding pages
11. Permitting printout of listing on a specific unit, or arranging for output of listing on five-track PL
12. Permitting printout of character file on a specific unit (when editing), or arranging for output of character file on five-track PL
13. Arranging for printout of contents of memory in octal codes, or output of PL with these codes, with an indication of the address of the cell and its contents
14. Permitting output onto PL of contents of the memory in binary codes, for both system areas of the memory and for up to 10 arbitrary sections, either onto a common PL or with formation of an individual PL for each section (as desired by the operator)
15. Readout for printing messages in the case of incorrect instructions, and arranging for normal continuation of editing or translation after these instructions have been cancelled or replaced by the operator

In addition, as already mentioned, when demanded by the operator the UIS can perform any standard editing or translating operation provided for by the structure of the editor or translator.

When a program listing or character file text is read out onto PL, the model of the printed document and of all its attributes is maintained (line blank, headings, page numbers, messages regarding errors, etc.).

The PL obtained in this way is printed out on a self-contained teletype (without employing the computer) by means of a transmitter accessory, which makes it possible to obtain any program or page printing without loss of paper.

Practical Results of Modernizing the Editing and Translation System

1. There has been a reduction in the number of working PL's for the editing, translation and I/O systems from a few score to two united PL's, one of which contains the editor and UIS, and the other the "Mnemokod-M" translator and the UIS.
2. There has been complete elimination of expenditure of machine time for preparation, configuration and obtainment of working PL's for numerous variants of the I/O, translator, and editing systems, and of other software, and for reloading them in the process of operation.
3. Efficient access has been ensured for any available printer.
4. Efficient selection has been guaranteed for the type of PL during I/O in the process of obtaining binary and character tapes in the editing and translation modes and working tapes for absolute systems whose configuration is complete (by means of memory content readout programs).

5. Maximum simplicity and convenience have been ensured for the programmer's work in editing and translating programs.
6. Paper consumption has been reduced approximately 20 percent.
7. There has been complete elimination of loss of machine time for repeated printing of documents because of nonprinting of individual lines or pages for various reasons (torn paper, unit malfunctions, passage of poor-quality section of inked tape, etc.)
8. The operating resources of external PL input and output units have been increased approximately sixfold.
9. Expenditure of machine time for editing programs has been reduced fivefold on average.
10. Expenditure of machine time for translation of programs has been reduced sevenfold on average (without an ATsPU).
11. Expenditure of paper and machine time has been reduced twofold when obtaining working PL's for absolute systems (cf. table 1).

Table 1. Comparative Characteristics of Translation and Editing of Programs for M-600 Computers in the Standard Mode and When Using the UIS

Mode	Operations performed	Total performance time in min		Program, format	Program size
		Std.	UIS		
Translation of PL	Loading and starting system; requesting information on errors and reading them out; Obtaining binary PL, table of identifiers and program listing	70	10	UIS supervisor. Absolute program	510 statements
		72	10	UPK driver. Relocatable program in DOS RV [time-sharing disk operating] system	535 statements
		56	8	Relocatable program	405 statements
Obtaining binary system tapes	System entry. Starting system. Obtaining binary PL	4.5	2.25	Absolute binary UIS format	6000 cells

[Table continued on following page]

Mode	Operations performed	Total performance		Program, format	Program size
		time in min	Std. UIS		
Editing	Entry and startup of system. Computer-operator dialog. Entry of editor file. Obtaining PL and listing of modified file	55	10	UIS supervisor. Absolute program	422 statements

Range of Application and Further Development of the UIS

The UIS described here can be used in any M-6000 computer complex having a memory of no lower capacity than 8K, for editing programs written in any language, and for translating programs written in the "Mnemokod" language, using a "Mnemokod-M" translator containing a translator generation program. With the presence in the structure of the computer complex of a wide-scale printer (ATsPU), it is necessary to add an ATsPU driver to the memory in place of one of the text information I/O units (the VVU or UPK driver) and to use the other driver for entry of text information in the dialog mode.

When joining the UIS to translators from other languages (FORTRAN, ALGOL, etc.) it is necessary to develop auxiliary software (30 to 40 instructions in size) for configuration of the appropriate translators. Employment of the standard UVPL-8 driver developed by the Impul's NPO in the UIS is not permitted.

At the present time at the TsPKB for Systems for Automating Production work is under way on improving the UIS, including expanding the combination of peripherals, modifying the PL entry mode to avoid breaks in PL, improving the system's adaptability, etc.

Documentation of the System

The system's text documentation comprises one volume of 160 pages. The system's media include binary tapes for the translating and editing subsystems and binary and character tapes for all the system's software.

COPYRIGHT: Izdatel'stvo "Mashinostroyeniye", "Pribory i sistemy upravleniya", 1978

8831

CSO: 1870

UDC 681.326

PROBLEMS IN CREATION OF AN AUTOMATED DEBUGGING SYSTEM FOR THE M-7000
PROCESSOR

Moscow PRIBORY I SISTEMY UPRAVLENIYA in Russian No 5, 1978 pp 9-11

[Article by F.F. Buchakchiyskiy, V.F. Litvinenko and M.A. Lobak, engineers]

[Text] Making a computer is the logical conclusion to the stage of automated design of a computer. At the design stage are created all the raw data for production. In fig 1 is shown a formal flowchart for production of computers, as applies to the ASVT-M [Standard Unit System of Computer Hardware] M-7000.

This article deals with one of the aspects of automating production: checking the results of assembly operations and general installation of standard replacement components (TEZ's) and bunched conductors, and debugging and testing the processor, units and complexes.

Debugging of computer complexes is concluded in practice at the customer's site in solving his problems, since here takes place the process of running in all equipment components.

The process of making a computer is labor intensive, cumbersome and diversified. Therefore, the problem of detecting errors at the early stage of making the computer is a quite crucial one. No slight role is played here by the structure of the technological process and by monitoring operation by operation. The technological process, in turn, depends on the design of the computer and basic logical elements and the design features of TEZ's and units. A high degree of unification makes it possible to reduce the total number of types of technological processes and operations, to raise their equipment availability factor, and to automate operation by operation monitoring. The chart shown in fig 1 reflects the high degree of unification of the M-7000 computer.

Manual testing of TEZ's and bunched conductors is a tedious and time-consuming process, which does not guarantee total detection of errors. In mass production this kind of testing requires high-volume expenditure of labor. The operations of testing general installation and bunched conductors were automated first. In particular, an automatic installation tester (AKM) was created. A highly difficult situation was complicated in testing TEZ's by

the increase in the degree of integration and miniaturization of components. Here the following problems have been solved in the order of their occurrence: 1) creation of complete testing situations to answer the question "Suitable or Unsuitable," i.e., obtainment of total testing programs; 2) finding of test procedures for finding the malfunctioning element and relaying this to the operator, i.e., obtainment of diagnostic software and malfunction dictionaries; 3) discovery of methods of rapidly obtaining testing and diagnostic software and malfunction dictionaries for new TEZ's, which is needed because of the growth in the number of TEZ's and their frequent replacement because of the development of new types of computers; 4) automation of adapting testing and diagnostic software to specific hardware for testing TEZ's; 5) development in connection with these circumstances of general-purpose hardware adapted to automatic testing of TEZ's.

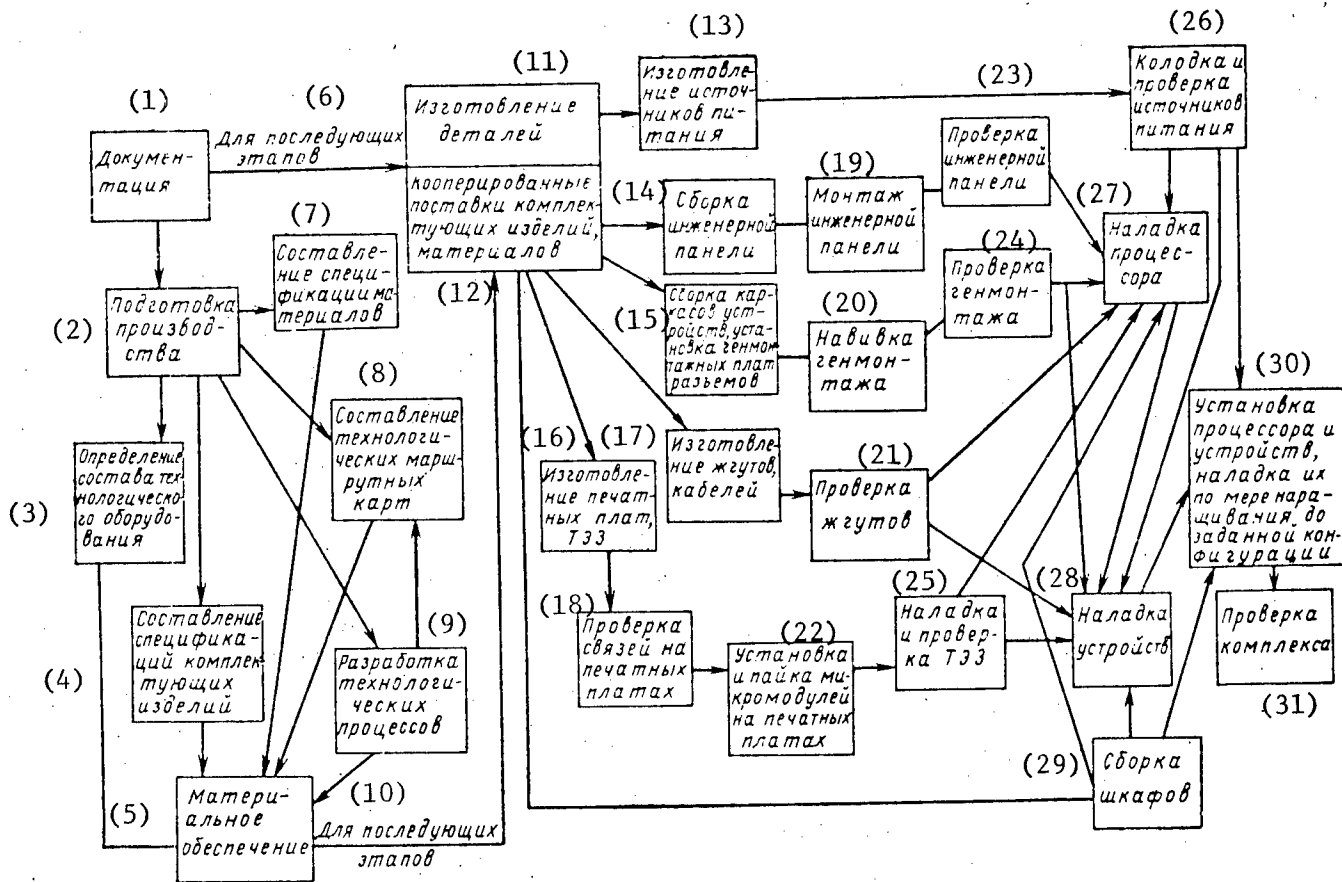

Figure 1.

[Key on following page]

Key:

1. Documentation
2. Preparation for production
3. Determination of combination of technological equipment
4. Writing specifications for outfitting items
5. Supply of materials
6. For succeeding stages
7. Writing specifications for materials
8. Drawing up technological routing charts
9. Developing technological processes
10. For succeeding stages
11. Making parts
12. Cooperative-system delivery of products and materials
13. Making power supplies
14. Assembly of engineer's console
15. Assembly of frames and units, installation of general-mounting plug connection panels
16. Making printed circuit boards and TEZ's
17. Making bunched conductors and cables
18. Testing connections on printed circuit boards
19. Installation of engineer's console
20. General rewiring
21. Testing bunched conductors
22. Installing and soldering micro-modules on printed circuit boards
23. Testing engineer's console
24. Testing general wiring
25. Debugging and testing TEZ's
26. Plugging in and testing power supplies
27. Debugging processor
28. Debugging units
29. Assembly of cabinets
30. Installation of processor and units and debugging them as the specific configuration takes shape
31. Testing complex

At the present time this problem has been partly solved: An automatic module testing bench (ASPB) has been created, along with a standard-unit testing console (APK-1) and automatic systems for obtaining testing and diagnostic software.

Methods of developing verification and diagnostic tests and the test equipment available do not guarantee complete testing of modules, a portion of the errors in which can be detected at the stage of debugging the unit or computer complex. Testing of units and complexes consists in the fact that program tests have been developed for units and test problems for complexes. Furthermore, there remain in the equipment components which can be tested only under special conditions, and these conditions cannot be created in running tests and test problems. For example, debugging of the processor continues even as the complex is debugged as the combination of equipment expands. In independent debugging of the processor, and often in complexes, too, certain modes remain untested, such as operation with an arithmetic extender and with a diagnostic testing and startup module in a two-processor complex, and the operation of automated machines for intrasystem coupling with channels, the I/O (input-output) line, and the common memory field line. Localizing

malfunctions when debugging units and complexes is a labor intensive process requiring highly skilled personnel and the presence of a great number of TEZ's and units of the same type for possible replacement of questionable and malfunctioning TEZ's and units. These replacements hamper subsequent analysis of the reasons for rejects.

The whole group of difficulties enumerated makes it necessary to formalize the process of debugging units and complexes. The process of obtaining testing and diagnostic software is like the process used for TEZ's, but it has its own specific features for units and complexes.

For TEZ's a sure solution has been found for the problems of where to apply the coded testing (diagnostic) sequence and from where to read the coded output sequence (the reaction to the input sequence) and this means that a solution has been found to the problem of the instant of occurrence of the malfunction and the structure of test equipment and the combination of requirements for it have been found.

In creating a system for automatic testing and debugging of units and complexes a number of problems arise, such as the following, for example: If the testing code combinations are known for individual components of the unit, then how can they be created after feeding the appropriate instructions and information to the unit's input, and how do malfunctions in components show up in the operation of units; what equipment is to be used to test and debug units and complexes?

The following methods of solving this problem exist: To develop debugging consoles, or to utilize a computer complex adapted for technological debugging purposes and supplemented with debugging testers.

In the process of debugging units and complexes it is important to know exactly which structurally independent part of it is malfunctioning, in order to shorten the debugging period by simple replacement of the malfunctioning design element (a TEZ in a unit and a unit in a complex), excluding analysis of the malfunction from key production cycle time. This formulation of the task results in the fact that the dictionary of malfunctions for units is shortened, since it includes symptoms for a malfunctioning TEZ, and not for an individual logical element, as was done in the dictionary of malfunctions for TEZ's.

To determine methods of automatic testing and debugging it is important to introduce the following classification.

1. According to design feature: a) The units contain TEZ's; b) the units do not have TEZ's.
2. According to functional feature: a) processor type (processor, general-purpose arithmetic extender (RAU)); b) channel type (channel with direct access to memory (KPDP), I/O extender (RVV), 2K link divider (RS2K), RS(2K) adapter, data transmission units); c) I/O units, peripherals (UVV's); d) units for communicating with the process (USO's); and e) memories (OZU's and PZU's).

Units of type 2b-d are connected to the processor via a unified 2K link and are in relation to the processor terminal units of the first stage; units of type 2b have the same unified link at their output for connecting terminal units of succeeding stages, under which heading can also come units of type 2c and d.

To automate debugging of units of type 2b-e it is a good idea to employ standard equipment including a computer complex consisting of a processor, OZU [main memory], process simulator, and diagnostic software.

Problems relating to automating debugging of a processor include testing general wiring, bunched conductors and TEZ's, and diagnosing units. This formulation of the problem has become possible as the result of unification of design elements of units, employment of a unified system of logical elements, and unification of signals and TEZ's.

By means of the debugged processor are debugged the remaining units of the computer complex. The processor serves as the diagnostic nucleus for the entire computer complex. By employing the method of expanding zones in diagnosis and by properly selecting the sequence for diagnosing units, debugging of the complex begins with the processor, proceeds to debugging of units, and ends with debugging of the entire complex.

The M-7000 processor does not possess the ability for self-diagnosis. In spite of the fact that it is furnished with testing circuits, after assembly their good working order is questionable; beside this they are effective when the processor operates in conjunction with the OZU and UVV's and when running a program.

Before proceeding to debug the processor, it is necessary to have its diagnostic center [1,2], which should be external, have maximum capabilities for acting on the processor and analyzing the processor's reactions to its influence, perform an instrument and function diagnosis, and utilize features of the processor's fundamental circuitry and of a program automaton with strict logic. The goal in pursuit here is that the information received on the malfunction be certain and complete, and therefore it must be received and analyzed at a time closest to the moment of occurrence of the malfunction in the equipment.

Let us examine a model of the M-7000 processor for the purpose of determining its capabilities for diagnosis, the strategy for diagnosing it, and for determining the specific objectives of the external tester and its structure. We will use a model of the circuitry design of an M-7000 processor (fig 2) which contains an operating section (OCh), a data transmission unit (UPD), an arithmetic and logical unit (ALU), and a control circuit or automata (SU).

Proceeding from a model of the block diagram of the processor (cf. fig 2), let us determine the sources of a diagnostic input routine for the processor.

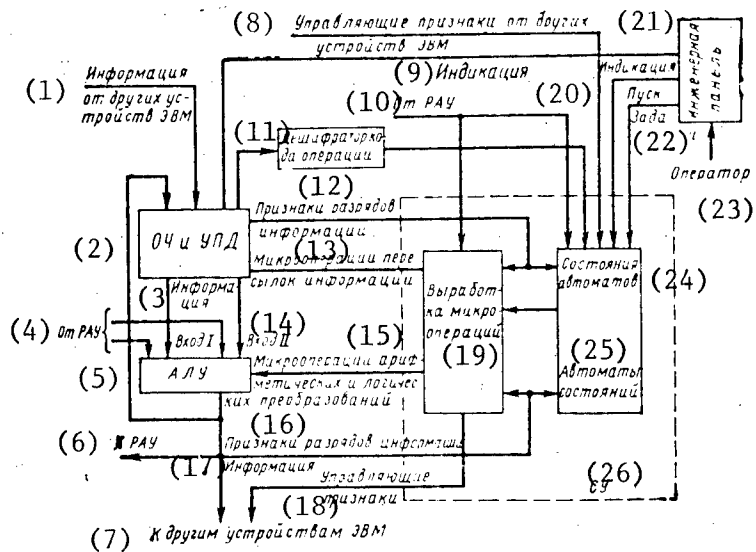

Figure 2.

Key:

- | | |
|---|---|
| 1. Information from other computer units | 15. Arithmetic and logical conversion microoperations |
| 2. OCh and UPD | 16. Information bit operations |
| 3. Information | 17. Information |
| 4. From RAU | 18. Control operations |
| 5. ALU | 19. Generation of microoperations |
| 6. To RAU | 20. Start |
| 7. To other computer units | 21. Engineer's console |
| 8. Control operations from other computer units | 22. Mode setting |
| 9. Readout | 23. Operator |
| 10. From RAU | 24. Automata states |
| 11. Operation code decoder | 25. State automata |
| 12. Information bit operations | 26. SU |
| 13. Information copying microoperations | |
| 14. Input I, Input II | |

For the OCh and UPD as these sources serve information in the processor's input from other units and the characteristics of microoperations for copies from the SU; for the SU the characteristic of the instruction arriving from the operation code register decoder, the start signal, the sign for continuation of the operation of the control automaton, and operations from the

processor's OCh; and for the ALU information from the OCh at its two inputs and the sign of the microoperation from the SU for arithmetic or logical conversion of this information.

Let us determine the possible points of observation: the output lines of the processor, the readout points of the processor's OCh, and the points for reading out the characteristic states of the SU.

The model shown in fig 2 is in the form of a complex logical circuit with feedback loops which are broken for carrying out diagnostic procedures. The break takes place between the OCh and ALU by feeding to the inputs of the latter information from the RAU [2], and between the ALU and SU by feeding signs for the same microoperations, and between the OCh and SU.

Thus, it is possible to control the ALU and test it apart from the SU and OCh and to control the OCh and ALU and test them apart from the SU. If the readout outputs are cut off from the engineer's console to analyze them by means of external tester equipment, then the operator is eliminated from the process of testing the OCh and ALU.

To diagnose the ALU its output acts as the testing point. The time for exerting an effect and obtaining a reaction at this testing point takes a single processor cycle. The same is true of relaying data from the RAU to OCh registers. The result can be observed at the outputs of the registers in their readout mode, or when forwarding the content of the registers through the ALU to the output to the RAU. All effects exerted must be clocked. Acting as actuating members can be the inverter registers of the external tester, and as testing point receptors, the registers of the external tester. When testing the ALU one or two operands must be supplied and one conversion microoperation.

To utilize the output of the readout circuit in the automatic mode without the assistance of the operator, the engineer's console is cut off from the processor by means of plug connections, the receptors are connected to the readout lines, and modes are set by the outputs of the external tester's flip-flops, imitating the keys the operator uses to set modes and information from the engineer's console.

The procedure for diagnosing parts of the processor is as follows: A check is made for the good working order of first the output, then the transmitting, and, third, the conversion circuits of the ALU. Then a check is made of the good working order of the OCh and UPD, and at the same time of the outputs of circuits for microoperations for relaying to the SU. After this a check is made of the SU.

To test the SU, in each operating cycle of the processor a test must be made of the state of the automata (a logout must be made), the information at the output of the ALU and at the outputs to other units must be checked, and the state of the registers must be checked.

In the M-7000 processor a logout, testing of the output of microoperations, and readout of registers while carrying out instructions have not been provided for. It is possible to check information at the output of the ALU and at the outputs to other units, and from the number of cycles for carrying out instructions.

Diagnosis of the processor must begin with setting the initial state. After determining the input and output points of the processor, the nature of the information, and the strategy for looking for malfunctions, it is necessary to determine the structure of the external tester. This is regarded as the controlling and testing part of the tester-processor diagnostic system. To take into account conditions of practical implementation, the tester should be designed on the same component basis as the processor.

In diagnosing the OCh and ALU, after exerting a single effect the final result can be analyzed by observing the output of the ALU.

It is a good idea to design the tester with accumulators for each output of the processor, and these accumulators should store information in each cycle. It is necessary that their capacity equal the number of cycles of the maximum path of an automaton.

As the external tester it is recommended that use be made of ready-made computer hardware, i.e., a computer with a set of USO and an adapter for communication between the processor and diagnosing computer. Most acceptable as an adapter is an automaton with microprogram control synchronized with the processor being diagnosed.

In this case it is possible to feed input routines during the processor's operating cycle and to receive reactions from the processor at clocked time intervals at the moment they occur. The adapter can become, with an advanced system of instructions, an independent diagnosing minicomputer.

BIBLIOGRAPHY

1. Parkhomenko, P.P. "Problems in Technical Diagnosis and Principles of Designing Diagnostic Systems" in "Trudy II Vses. soveshch. po tekhn. diagnostike" [Proceedings of the Second All-Union Conference on Technical Diagnosis], No 118, Part I, Leningrad, LETI [Leningrad Institute of Electrical Engineering], 1972.
2. Gol'dman, R.S. and Chipulis, V.P. "Tekhnicheskaya diagnostika tsifrovyykh ustroystv" [Technical Diagnosis of Digital Equipment], Moscow, Energiya, 1976.

COPYRIGHT: Izdatel'stvo "Mashinostroyeniye", "Pribory i sistemy upravleniya", 1978

CYBERNETICS, COMPUTERS AND AUTOMATION TECHNOLOGY

IL'ICHEVSK TRANSPORTATION CENTER WORKS ON CONTINUOUS SCHEDULE-PLAN

Moscow VODNYI TRANSPORT in Russian 6 Jun 78 p 2

[Article by Ye. Krushkin, deputy chief of the Port of Il'ichevsk in charge of economics and management, candidate of technical sciences: "The Organization and Hardware of the NPGRTU"]

[Text] One of the primary tasks in development of our country's transportation in light of the decisions of the 25th CPSU Congress is achieving coordinated operation of all types of transportation as constituent parts of a single transportation system. This envisions the establishment of organizational forms for interaction during the entire process of shipping freight and cargo.

The initiative of the Leningrad Oblast party organization, approved by the CPSU Central Committee, to switch transportation enterprises based on the Port of Leningrad to continuous interrelated planning has raised a number of important issues that demand fixed attention.

Practical realization of cooperation by the enterprises of the Il'ichevsk transportation center to introduce and coordinate their work has been assigned by the chiefs of the Black Sea Maritime Steamship Line, the Odessa-Kishinev Railroad, the oblast administration of motor vehicle transportation, and the office of the All-Union Soyuzvneshtans [USSR Foreign Transportation] Association to a coordination group whose work is directed by the chief of the port. Managers from all enterprises of the center are included in the group.

The coordination group has worked out a program of introducing and improving continuous planning of work at enterprises of the center by stages and set times and dates for each week of work. Between meetings of the group, using the NPGRTU [continuous schedule-plan of the work of a transportation center] the work is analyzed at daily dispatcher meetings held at the port with participation by representatives of all associated enterprises.

Until the present time the hardware of the automated control systems being set up at enterprises of maritime, rail, and motor vehicle transportation has developed in isolation, aiming at supporting the production processes taking place within each enterprise. Taking into account definite characteristics of the work of each enterprise of the center, the automated control systems being built were supplied with various types of electronic computers. In the first stage of incorporation of the NPGRTU this is slowing down its introduction.

From the very beginning of the introduction of the NPGRTU at the Il'ichevsk transportation center we ran into certain difficulties related to a shortage of hardware for the information and computing center. The presence of different types of computers required conversion of the machine programs of the NPGRTU used at the port information and computing center before they could be used at the computing center of the Odessa-Kishinev Railroad.

The algorithm of the machine program for drawing up the NPGRTU developed at the Port of Il'ichevsk envisions performance of a broad range of operations, including operations to insure a reduction of labor expended to prepare initial data for compiling, correcting, and transmitting the NPGRTU or supplementing it over communications channels. A distinguishing feature of the organization of information processing at the port information and computing center is that the NPGRTU of the preceding days is stored in the computer memory. The forms of input documents for correcting and supplementing the NPGRTU of preceding days are constructed in such a way that all that is required to compile the schedule for the days being planned is to feed changes in the production situation to the computer. This approach, realized in the algorithm of the machine program, greatly reduced the labor-intensiveness of managing the NPGRTU.

Effective functioning of the NPGRTU can be insured where there is an appropriate system of control provided with modern dispatcher communication equipment. However, the dispatcher communication systems for the port, railroad station, and other associated enterprises have developed independently. Introducing the NPGRTU requires coordinated development of this system. As quickly as possible we must set up an elaborate system of dispatcher, loudspeaker, direct telephone and telegraph communication and equip a studio with the technical means required to coordinate and reconcile operational questions in drawing up plans, keeping records, and making out reports to analyze the work of the transportation center. While working out these important questions it is essential to bear in mind that significant amounts of formalized information will be transmitted among the subdivisions of the allied enterprises.

Experience with the development of computing capacities at ports shows that so far only one management process has really been automated: processing the raw document data essential for making decisions at

different levels of management. But the effectiveness of a system of continuous planning for an entire center depends on the degree of automation and mutual coordination of processes of data processing and transmission at enterprises of the center.

How much time savings and accuracy will be achieved in performing the NPGRTU by computer if a great deal of time is lost delivering the results of the work to the addressee? The experience of the transportation workers of Il'ichevsk and Leningrad indicates that 7-8 hours are usually spent between the beginning of data collection and obtaining a coordinated NPGRTU, with no more than 20 minutes of this being machine time for processing data and supplementing the NPGRTU. This explains the necessity of first of all automating the processes of data transmission by communication channels in the later stages of intermachine (interprocessor) exchange of data among enterprises of the transportation center.

Using computers to compile the NPGRTU does not by itself constitute automation of the control system of the transportation center. In this case the computer can be compared to a large, complex, and expensive adding machine. The computer can be turned into the central, chief element of a data processing system only where it is intelligently combined with various types of communication and auxiliary equipment which insure the collection, preliminary processing, and input-output of data to or from the machine on a remote basis using communication channels.

The railroad stations, offices and depot of the Soyuzvneshtans Association, and motor vehicle transport divisions do not now have computers and, it appears, will not have them in the near future. Therefore, it is essential to install receiving and transmitting equipment and wide-page printers at the control points of these enterprises to transmit information to the computing center and print out NPGRTU forms arriving for use. Our country's industry is producing a sufficiently large assortment of these devices, and the sectorial ministries must solve the problems of equipping these subdivisions with appropriate hardware. Only then is it possible to continue developing and refining work using the NPGRTU.

The information support of the system is important if not decisive in effective functioning of the NPGRTU. Information on ships arriving in the port, of course, is sent to the ports by the ship owners. After almost two years of working with the NPGRP [continuous schedule plan of the work of a port] we have some experience with the preparation and transmission of data by ship owners to ports and its processing at the ports. There is no such experience yet with NPGRTU operations in rail and motor vehicle transportation. Indeed, the railroad management has information on loaded and empty cars for the port only 1-2 days ahead and even this information does not contain all the data required to compile the NPGRTU. Therefore, it is

essential as quickly as possible to work out systems for collecting information at all input stations of the railroad, transmitting this information to the railroad computing center, grouping it by computer, and transmitting it to the port information and computing center for use in compiling the NPGRTU. In view of the complexity of this problem, both on the organizational and technical levels, sectorial scientific research institutes must be brought in. Additionally, the "depth" of information for two days ahead which the railroad can provide in working out the information support system of the NPGRTU, is far from adequate; after all, the NPGRTU is drawn up for a period of 10-20 days. Therefore, the Ministry of Railroads must be directly involved in working out information support for the NPGRTU. Only in that case will it be possible to develop a system of information support that is "deep" enough for the NPGRTU.

We consider the organization of jobs in compiling the schedule on the computer and transmitting the forms of the NPGRTU obtained directly to those who will carry it out to be an important aspect of the efficient functioning of an NPGRTU.

There are several possible alternatives for information exchange among the computing centers of the enterprises of the transportation center and for organization of jobs in compiling the NPGRTU on electronic computers. All we need to observe here is that in all of them one of the computing centers of the transportation center must be given the status of head or chief computing center.

The first alternative. The information necessary and adequate to compile the NPGRTU is delivered to the head computing center in the form of documents, as is done at the present time. The technical carriers are made up at the center and processed by computer, resulting in the NPGRTU. This scheduleplan is duplicated in the necessary number of copies and delivered to all enterprises of the transportation center. They, after looking over the NPGRTU, return their remarks about it and these are taken into account in shaping the reconciled NPGRTU which is then delivered to the enterprises to be carried out.

The second alternative. Information is transmitted by the enterprises of the transportation center to the head information and computing center by communication channels. There it is processed by computer and the output form of the NPGRTU is made up using the NPGRTU for the preceding days that was stored in computer memory. The new output form is printed. The head information and computing center duplicates the NPGRTU only for the needs of its own enterprise. The information and computing centers of all the enterprises of the transportation center have the NPGRTU of the preceding days stored in the memory of their computers and they have machine programs to run it. In this case, the only thing the head information and computing center sends along communication channels is supplements and changes in the NPGRTU of the preceding days. They go to all the information and computing centers

of the transportation center which put them together with existing programs to obtain the NPGRTU for the planning period and print out the necessary number of copies of the schedule for those who will carry it out.

At the same time, there is a critical problem with setting up an efficient system of communication within each enterprise of the center. For example, at the present time the Port of Il'ichevsk has only operational telephone and loudspeaker communication. But the management of production processes in the loading-unloading areas and sections of the port requires the collection and transmission of large volumes of operational information by communication channels. Some of this information is intended for computer processing, but at the present time it circulates in documents of different form and content. Therefore, in the first stage we must set up internal telegraph communication with automatic telegraph stations. We intend to establish this kind of communication in our port in 1978, but this is only a partial solution to the problem. At the same time we must note that the port has virtually no subscriber telegraph devices. This discrepancy obviously must be taken care of.

Our brief experience in the port with using third-generation computers testifies that to employ them efficiently we must immediately set up subscriber points right at the work sites (dispatcher rooms, warehouses, and the like). These points must have screen-type consoles with keyboards or data indication units for data input-output to the computer as well as units to print out information right at the work site.

While the delivery of screen-type consoles to ports can be considered taken care of, the questions of supplying ports with equipment for communication between these consoles and computers (parallel data transmission units) and printers have not been resolved. We have screen-type consoles and modern computers, but we cannot organize joint work by these expensive units at the work sites because of the lack of data transmission units.

Because port workers have some experience with questions of the organization and practical realization of interaction among associated enterprises at the Il'ichevsk transportation center, the main lines of action in improving the entire system of continuous planning that has been successfully realized in maritime transportation, at the port of Il'ichevsk in particular, are now clear.

Among the problems whose solutions will, in our opinion, promote most effective introduction of continuous planning at the Il'ichevsk transportation center and later creation of a network of transportation centers in Odesskaya Oblast we include the following: definition and practical embodiment of the principles of mutually coordinated planning of the work of transportation enterprises to achieve the primary

goal of performing state plans with minimum expenditures of resources and most efficient use of them; improving the system for collecting information on the state and dynamics of the development of transportation processes at the center and improving the effectiveness of the computer equipment used by enterprises of the center to form the NPGRTU; developing and implementing remote data transmission quickly, including providing the hardware; organizing interaction and mutual replaceability among the computers of the information and computing centers of enterprises of the transportation center in shaping the NPGRTU; developing and implementing an effective system of recording and analyzing NPGRTU's for working out management decisions; training specialists of enterprises of the transportation center to work under conditions of continuous planning based on schedule plans; working out standards for planning and management goals; establishing conditions for effective coordination of the work of the enterprises of the transportation center.

The questions of receiving information from enterprises that deliver export products to the port and procedures for including this information in the unified information support system for the continuous planning system being introduced in transportation require special consideration.

The solutions to all these complex problems must be found during the process of broad introduction of continuous planning at all enterprises of the transportation center, bearing in mind that some problems will be difficult or completely impossible to solve entirely through the efforts of the ports, stations, and other enterprises of the center. Therefore, the ministries must provide effective help, especially in questions of hardware for the information and computing centers, channel forming equipment, providing peripheral units for existing computers, and involving sectorial scientific research institutes in working out the organizational and information support necessary for continuous planning of the work of transportation centers.

11,176
CSO: 1870

PLANS FOR AUTOMATION IN THE UKRAINE

Kiev MEKHANIZATSIYA I AVTOMATIZATSIYA UPRAVLENIYA in Russian
No 1, Jan-Mar 78 signed to press 15 Feb 78 pp 1-5

[Article by V. P. Shevchenko: "Mechanization and Automation of Production Processes--A Major Direction of Scientific and Technical Progress"]

[Text] Under the conditions of a developed socialist society, when the task of creating the material and technical base for communism is being practically resolved, scientific and technical progress is a key problem in the development of the soviet economy.

In an address at the ceremonial session dedicated to the 60th anniversary of Great October, general secretary of the CC CPSU, chairman of the Presidium of the USSR Supreme Soviet, comrade L. I. Brezhnev said: "The future of our economy lies in raising efficiency. There is no other way to ensure the successful dynamic development of the national economy. This is precisely why the party is conducting and will be conducting a policy for acceleration of scientific and technical progress and improvement in planning and management."

In resolving the task of accelerating scientific and technical progress, an important role is played by the problem of mechanization and automation of production which has great social and economic significance and is aimed at increasing labor productivity, improving working conditions, reducing manual labor and completely supplanting heavy physical labor.

Proceeding from these aims and tasks a broad program of measures is being implemented in the Ukrainian SSR aimed at

the mechanization and automation of basic production, auxiliary, materials handling, and warehouse operations, and the introduction and efficient use of computer technology.

More than 3,150 fully mechanized facilities have been placed into operation in the industry of the republic during the two years of the Tenth Five-Year Plan alone, including more than 30 enterprises, 460 shops, 2,655 sections, as well as about 4,870 mechanized flow and automatic lines. This has made it possible to raise the engineering level of production in the republic's economy and on this basis ensure further growth in labor productivity.

A major factor in the successful resolution of the problems on mechanization and automation of production are the efforts of the republic's scientists and designers aimed at developing new means of mechanization and automation of production in all sectors of the economy. In working up the state plan for 1978, the republic's Gosplan, Academy of Sciences, ministries and departments have paid special attention to including the final stages in the plans so that efforts are concluded with real output and preparedness for introduction. In the coal mining industry, for example, experimental models of highly productive equipment will be developed and tested for mechanization of difficult and labor intensive processes.

At the Donbass mines, acceptance tests will be conducted for a prototype automated cleaning combine complex with a productivity of 3,600 tons per day for extraction of coal seams with a capacity of 1 to 1.4 meters of gentle and low dip with equipment for assembly and disassembly, as well as tests of a prototype of a band telescopic conveyer 2LBT-100 (1LT-100) with a productivity of 600 tons per hour and a length of 1,200 meters with a 12° grade.

A special role in the state plan has been allotted to the republic's machine building industry which is called upon to supply all sectors of the economy with highly mechanized and reliable equipment.

In 1978, in the machine building industry, it is planned to assimilate more than 500 new types of machines, mechanisms and instruments, and a large number of them are for mechanization and automation of auxiliary operations. For example, the L'vov Conveyer Plant will assimilate production of sets of equipment for high speed pushing conveyors with a 50 kilogram force car capacity and with semiautomatic loading and unloading devices and systems for automatic control.

The Aleksandriyskiy Hoisting and Transport Equipment Plant plans to assimilate production of gantry cranes with a capacity from 8 to 12.5 tons in spans of 40 and 32 meters respectively with space suspension and powered clamps for lumber. The Kadiyevskiy machine building plant plans to assimilate production of general purpose bridge stacking cranes with a 12.5 ton force capacity with interchangeable fork grippers and automatic control, as well as test units for them.

Along with an increase in the output of specific types of equipment for mechanization of auxiliary and transport-warehouse operations, work will be done on developing complex installations which provide automatic selection and delivery of objects of labor.

In the area of improving the tools of labor, a radically new direction will be taken--development and introduction of automatic manipulators with program control (industrial robots) for mechanization and automation of the most difficult and monotonous operations in welding, forging, machining and heat treatment, and assembly.

The state plan for 1978 calls for implementation of a large volume of work on full mechanization of industrial processes in all sectors of the republic's economy, on mass application of highly efficient systems of machines, equipment, instruments and industrial processes, which provide mechanization and automation of all processes of production, especially auxiliary, transport and warehouse operations. In republic industry alone, it is planned to fully mechanize and automate 24 enterprises, 326 shops, 1100 sections, which overall is 7.6 percent more than in the 1977 plan. For organizations under the Council of Ministers of the Ukrainian SSR, it is planned to fully mechanize and automate 24 enterprises, 180 shops, and 1,026 sections, which is 11.8 percent more than in 1977. In accordance with the Five-Year plan, 2,600 mechanized flow and automatic lines will be put into operation in the republic, including 1,120 lines for organizations under the Council of Ministers of the Ukrainian SSR, which is 6 and 12 percent more respectively than in 1977.

Fulfillment of the plan measures for full mechanization and automation of production will make it possible to transfer more than 60,000 people from manual to mechanized labor and raise the share of workers whose labor is fully mechanized to 48 percent.

Corresponding programs of work have been developed by the Gosplan of the Ukrainian SSR together with the republic's ministries and departments to improve the organization of work in raising the level of mechanization and automation of production and accelerating scientific and technical progress.

Widespread introduction of computer technology is planned through development of automated control systems aimed at further automation of industrial processes, and the planning and management of the economy in the Tenth Five-Year Plan.

Computer hardware with a total capacity of over 17 million operations per second has been placed into operation during the two years of the current five-year plan in the economy of the Ukrainian SSR. During this time, 102 ASU [automated control systems] have been developed, including 64 in industry which in the process of operation make it possible to solve major industrial problems. Thus, the first section of the ASU of the Odessa Precision Machine Tool Plant of Minstankoprom [Ministry of Machine Tool and Tool Building Industry] introduced on the base of a multiple user information and computing center, is effecting a reduction in overhead and loss from rejects, rise in profit from growth in sales, and improvement in the use of productive capital. The pay off time for development and introduction of this ASU is 2.3 years against a standard of 2.9 years.

The ASUTP [automated systems for control of industrial processes] introduced at the beginning of the current five-year plan at the "Krasnoarmeyskaya-Kapital'naya" Mine of the "Krasnoarmeyskugol'" production association of the Minugleprom [Ministry of the Coal Industry] of the Ukrainian SSR, at blast furnace No. 9 of the Krivorozhskiy Metallurgical Plant imeni Lenin of the Minchermet [Ministry of Ferrous Metallurgy] of the Ukrainian SSR, at the Khar'kov Turbine Plant imeni S. M. Kirov of the Minenergomash [Ministry of Electrical Machine Building] and others are highly efficient (pay off time is less than one year).

Further steps will be taken in 1978 to improve the structure and methods of control of production, improved planning, accounting and reporting, and to order norm management on the base of the growth of the level of mechanization and automation of this work with the application of the computer.

Overall in 1978 in the republic's territory, it is planned to introduce 82 new ASU, to establish 29 VTs [computing centers], and to put 97 computers into operation in the

operating VTs, as well as in a number of institutes and organizations. Computer hardware with a capacity of about 15.25 million operations per second will be placed into operation. For the ministries and departments of the Ukrainian SSR it is planned to establish 47 new ASU, 18 VTs, and to place 49 computers into operation with a total capacity of 7.77 million operations per second.

The greatest amount of work in introducing computer technology in the republic is planned to be performed in the enterprises and the organizations of Minenergo [Ministry of Power and Electrification], Minchermet, Minugleprom, Ukrsel'-khoztekhnika [Ukrainian Agricultural Equipment Association], and Minavtotrans [Ministry of Automobile Transportation].

To fulfill the 1978 plan and to raise the effectiveness of the introduction of computer technology, the ministries and departments, associations, enterprises and organizations must organize immediate development and introduction in the composition of tasks planned to be brought into use in the ASU, aimed at revealing and activating reserves of production, improving the use of labor, material, and financial resources, fixed capital, and raising the quality of output, and in the process raise the effectiveness of outlays for development of ASU not less than by 25 percent.

The spare computing capacity of the information and computing operations of external users should be fully loaded under mutually advantageous conditions and in a systematic way.

Ministries and departments must not permit duplication of high cost development of designs for ASU and programs for VTs in facilities under their jurisdiction. This work must be coordinated and cooperatively organized with allied ministries and departments. Radical improvement is also required in accounting for outlays of all types for the introduction of computer technology and their actual efficiency.

It is now not enough to mechanize specific operations and processes of control and to solve specific problems; it is essential to strive for a combination of the processes of control with direct productive processes and to ensure an organic merging of the control technology with the production technology.

One of the main tasks in improving the management of the national economy is in improving the system of national

economic planning. Systematic management requires a highly efficient process for development of plans and monitoring fulfillment of them, and timeliness in acquisition, processing and storage of economic information. These tasks can be carried out most efficiently under the condition of widespread employment of economic and mathematical methods and models, and new means of processing, storing and transmitting information within the framework of the automated system of plan calculations (ASPR), the first section of which was delivered to the interdepartmental commission in the republic in 1976.

Realization of the directions and the tasks of the functioning of ASPR will make it possible to improve the drafting of balanced plans for development of the republic's economy, enhance control over the fulfillment of plans, and on the basis of intermachine exchange of information, to organize effective cooperation between Gosplan of the Ukrainian SSR with other planning and control organs, to enhance the operativeness of the process of planning, to reduce the time for drafting plans, as well as to automate labor intensive calculations, which will make it possible to increase the capabilities of plan workers through more valid plan decision making.

The solution to the problem of interaction between the ASPR of the Ukrainian SSR and the ASU of various levels and purposes is especially important.

To achieve methodological, informational, program-mathematical, technical and organizational compatibility between these systems, a number of measures must be taken in drafting specialized project documentation and introducing common terminology.

Since the ASPR belongs to the category of large and complex systems, it is necessary to design it by subsystems with subsequent synthesis of them into a single system.

According to the plan, the ASPR of the Gosplan of the Ukrainian SSR will include 45 subsystems (9 enabling and 36 functional) which will make it possible to include the automation of the activity of all the functional subdivisions of the Gosplan of the Ukrainian SSR.

In the first section of the ASPR of the Gosplan of the republic, 23 functional and 3 enabling subsystems have been placed into operation.

The use of the automated system at the level of state planning for development of science and technology is a matter of especially great importance.

Development and introduction of the "Science and Technology" subsystem of the ASPR of the Gosplan of the Ukrainian SSR are continuing in the Tenth Five-Year Plan in the republic, while individual priority tasks (and complexes of them) are being worked on in parallel with preparation of the corresponding project documents and with the use of them in the practice of the work of the consolidation division for science and new technology of the Gosplan of the Ukrainian SSR.

These tasks in the first section of the ASPR of the Gosplan of the Ukrainian SSR are of an informational-reference, forecasting and analytic nature; their resolution will make it possible to more deeply analyze the state of affairs with the introduction of the achievements of science and technology in the republic, reveal some positive and negative trends, perform some calculations of a forecasting nature and thus take into consideration the obtained results in planning and calculations of a number of indicators of scientific and technical progress. Thus, the reference-analytic indicators, obtained in computer processing, of outlays and effectiveness of the introduction of new technology in industrial enterprises serves as the basis for determining the impact of this factor on the growth of labor productivity and savings from reduction in the production costs. Other indicators will make it possible to evaluate outlays for R&D performed by an industrial enterprise's own resources etc.

The information being stored will serve as the basis for working out forecasts of the movement of basic indicators. Use of the computer makes it possible to perform these calculations both for the republic as a whole, as well as for an industrial or regional profile (for example, for the effectiveness of outlays for introduction of new technology for industrial enterprises of the 55 ministries and departments and all 25 oblasts of the republic).

Reference-analytic information on the degree of mechanization and automation of industrial processes and the labor of workers in the industry of the Ukrainian SSR is gaining importance in planning-analytic work in connection with the growing urgency to reduce outlays for manual labor and to raise labor productivity through mechanization and automation.

Computers are currently used to calculate indicators of the degree of mechanization of labor in the industry of the Ukrainian SSR on an industrial and departmental profile, and the capability exists to calculate forecasts for these indicators.

Work on automation of calculation of indicators of the development of science and technology will be significantly expanded in the future. In particular, problem sets will be built for calculations of variants of the plan for savings from reduction in production costs, relative decrease in number of workers and growth of labor productivity through raising the engineering level of production in industry of the republic; for calculation of reference-analytic and forecasting indicators which describe the activity of scientific research institutions in the Ukrainian SSR; for calculation of new supplementary information on mechanization and automation of production and labor of workers, as well as the effectiveness of introduction of new technology.

To further raise the scientific and technological level of the ASPR of the republic, it is necessary to increase the number of subsystems introduced and the problems handled in them, increasing in the process the relative share of problems of optimization and forecasting, to improve the technical base of the system, to introduce new models of third generation computers, devices for automated acquisition, preparation and control of data, video terminals, data transmission equipment and to improve the use of them, and to make extensive use of the methods of automation of design.

Fulfillment of the tasks of the state plan, resolution of the above mentioned problems in mechanization and automation of production, improvement of the technical base for control, more efficient use of the means of mechanization and automation are the major factors in achieving the planned indicators for the third year of the Tenth Five-Year Plan for the tasks in growth of the volume of production and labor productivity and in improving the quality of the product output.

COPYRIGHT: UkrNIINTI, 1978

8545
CSO: 1870

SERIOUS PROBLEMS IN COORDINATING DEVELOPMENT OF RECHFLOT ASU

Moscow RECHNOY TRANSPORT in Russian No 1, 1978 pp 25-27

[Article by V. Nevolin, candidate of technical sciences, deputy chief of economic planning administration of the Ministry of the River Fleet: "Problems of the ASU Rechflot"]

[Text] The problem of improving the efficiency of designing and introducing automated control systems in river transportation, raised by the journal RECHNOY TRANSPORT in the article "Results of Work on the ASU-Steamship Line" by I. Dubrovin and Yu. Platov in issue No 9 for 1976, is a timely one.

The second phase of the Rechflot ASU [River Fleet Automated Control System] is to be built during the Tenth Five-Year Plan. Unlike other scientific-technical lines of activity, the Rechflot ASU is being developed with due regard for automation of control over all the multifaceted activities of the sectors. And in this there is no opportunity for preliminary exploratory research; all development projects underway must be introduced.

The need to insure the integrity, unity, and compatibility of all levels of the Rechflot ASU imposes special requirements for centralization of management of scientific and planning work. Expenditures for development and design of the ASU at the Ministry of the River Fleet constitute 30 percent of all expenditures for scientific research. There are now 450 development workers in the Rechflot ASU and the production computing centers have about 1,000 employees.

During 1974-1977 the first phases of the Parokhodstvo [Steamship Line] ASU were put into operation at the Volga Associated, Kama, Northwestern, Moscow, White Sea-Onega, and Volga Tanker Steamship Lines, the Port ASU was launched at the Moscow Northern and Southern ports, Leningrad, Gor'kiy, and Osetrovskiy, and the Rechflot sectorial ASU was introduced. Third-generation computers were launched at the Main Computing Center of the Ministry of the River Fleet and the computing

centers of the Irtysh and Kama river steamship lines, PVB [possibly Volga Basin Steamship Line], and PTsB [possibly Central Basin Steamship Line]. The economic effect from the introduction of the subsystems is more than 1 million rubles.

Analysis of the operation of the first phase of the ASU in ports and steamship lines showed that these systems are basically solving accounting and analytic problems and as a result do little to improve the effectiveness of control of the transportation process. TsNIIEVT [Central Scientific Research Institute of Economics and Operation of Water Transportation], GIIVT [Gor'kiy Institute of Water Transportation Engineers], and LIVT [Leningrad Institute of Water Transportation] are conducting few scientific investigations to develop economic and operations optimization models and still have not worked out the theory of modeling and optimization of the transportation process. The algorithm proposed by GIIVT for developing the fleet traffic schedule of the steamship lines of the central and northwestern basin has not yet been applied in practice because expenditures of time and money for automation of its calculation exceed manual calculations several times. The situation is similar with the subsystem "Calculation of the Technical Plan of Work of the Steamship Lines of the Central and Northwestern Basins" — preliminary processing and preparation of data for computer calculations takes more than seven days, instead of three.

Systemwide scientific work in the area of information support is inadequate. Such research should result in rationalization and standardization of document circulation, the use of plotters to shape initial documents, and rationalization of the technology for collection, processing, and movement of information by levels of control and within them. Shortcomings in this research field have led to a situation where the existing first phase of the automated control system at the level of the ministry, the Moscow Steamship Line, and the Moscow Southern and Northern ports is nothing but a mechanical combination of subsystems that are not interlinked, that are incompatible in data terms, and require substantial expenditures for everyday preparation and correction of data. As a result, the efficiency of the ASU is significantly lower than projected. In addition, the subsystems of the Rechflot ASU do not function stably in real time.

A significant shortcoming of scientific research in the ASU field is unsatisfactory development of the problem of drawing up load correspondences which are used in calculations in the subsystems for annual planning of shipments, the fleet traffic schedule for steamship lines of the central and northwestern basins, drawing up the technical plan of fleet operations for steamships line of the central and northwestern basins, and quarterly planning of shipments (at the level of the Rechflot sectorial ASU and the Parokhodstvo ASU). As a result of the striving of the developers to automate the calculations for this problem applicable to each specific subsystem (with the silent consent of TsNIIEVT as the head institute for the problem of ASU's), none of

the subsystems produces its calculations within the established time requirements.

The lag in scientific research has led to discrepancies in designing and introducing problems and subsystems for control levels. While data processing at the ministry and steamship line level has been automated intensively, the problem of collection of data directly from its sources (the ports and fleet) still has not been resolved. Preparation and collection of data for automated solution to the problems of the top and middle levels of management is a heavy burden on the administrative apparatus of the line enterprises, which prepare this information manually. This discredits the very idea of automated data processing and arouses a negative attitude toward it in line workers because data is prepared more than once (the idea of one-time data transmission for multiple use is not observed). The system of data transmission directly from ships as proposed by GIIVT is correct in principle, but its implementation will require substantial capital expenditures and a great deal of time. The Volga Tanker Steamship Line has gained useful experience in collecting all information on the fleet and using it over and over, but this know-how has not received broad dissemination.

The production computing centers, dissatisfied with the state and progress of design work by scientific institutions, have developed and introduced on their own a significant number of problems for data processing (the White Sea Omega and Volga Tanker steamship lines), using local data files and software. This has resulted in information and software incompatibility: differences in the composition and structure of reference and norm information, in the content and forms of primary documents containing output and input information, and different versions of standard software. The result of all this is that virtually every production computing center today has built its own information base. It should be observed that the Main Computing Center of the ministry, which is responsible for guidance on the methodological level, and TsNIIEVT, the head institute, have steered clear of this question. Although it is late, the Main Computing Center of the ministry has now begun conducting and coordinating this work.

Incompatibility in organizational support, information base, and software makes it impossible to fully standardize design decisions for identical steamship lines and ports at the problem level; in other words, it does not promote the formulation of standard design concepts and reduction of expenditures for the development and introduction of ASU's. Most of the program complexes being designed do not have the ability to expand, their programs are difficult to read, and modernization of them takes a great deal of time. The designs being developed are oriented to the existing hardware and the hardware complexes proposed in the designs do not guarantee problem solution on an automated basis for the entire production cycle. With some exceptions, start-to-finish designing of subsystems for all levels of control by a single

development organization is not being followed, which precludes the possibility of realizing a single conception in following standard decisions from top to bottom.

The system of organizing and coordinating scientific research on development and introduction of the Rechflot ASU must be fundamentally altered. One of the serious shortcomings today is the lack of a specialized scientific design organization for development and introduction of ASU's. TsNIIEVT, the ministry Main Computing Center, GIIVT, LIIVT, NIIVT [Novosibirsk Institute of Water Transportation Engineers], and the production computing centers of the steamship lines are working on the development and introduction of ASU's. The participation of a large number of organizations leads to duplication of work and scattering efforts and money.

TsNIIEVT is not performing the functions of head organization and provides poor coordination of work on building the Rechflot ASU. The other developers are not subordinate to TsNIIEVT in economic or administrative terms and the institute is not exercising adequate guidance concerning scientific methods.

A large number of advisory bodies have been set up: the Coordination Council on ASU Problems, the Council of Main Designers, and groups for start-to-finish designing. Their recommendations are not mandatory for all developers and an analysis of their work reveals poor cooperation among these bodies and a lack of precise boundaries to their activities and responsibility. The Council of Main Designers under the direction of the scientific leader for the problem is doing little work and not coordinating the activity of all agencies.

TsNIIEVT as the head organization in the field of fleet and port operation has not provided any fundamentally new scientific solutions which would provide scientific foundations for the building the Rechflot ASU. The existing divisions of TsNIIEVT "The Organization of Shipping and Fleet Operations," "The Economics Organization, and Technology of Port Work, and "Scientific Organization of Labor and Improvement of Wages" have not done anything in this area in recent years. The scientific research planned for 1978 under the heading "Development and Introduction of Scientifically Substantiated Proposals to Improve Fleet Use" does not contain a single scientific research topic aimed at solving this problem. It is common knowledge that the main direction in improving fleet and port operations is building automated control systems based on modeling the transportation process and structure of sectorial management and using computers as a management tool. Although it is the head organization for building automated systems in river transportation TsNIIEVT has just one division for "Automation of the Transportation Process." Needless to say, this small specialized division cannot perform the function of a head institute for the problem of the Rechflot ASU. In our opinion, the divisions of TsNIIEVT listed above should carry on their own work and coordinate the work of

other institutes and organizations in the area of improving methods of controlling the work of the fleet and ports on the basis of ASU's. Then the main problem for river transportation will be solved in a purposeful manner. Only in this way can the problems of automating the calculation of the schedule of fleet traffic and technical plan, operational planning and regulation of fleet work both at the level of the central administrative apparatus and the steamship line level, and shift or daily planning in the ports be solved.

If the existing situation with the organization of development work for the Rechflot ASU is not corrected, this system will not be a unified system in economic organization, technical, information, or software terms. The questions of interaction and insuring compatibility among interlinked subsystems of the Rechflot sectorial ASU, the Parokhodstvo ASU, and the Port ASU will not be solved, the labor-intensiveness and cost of development will not be reduced, and the pace of building automated systems in river transportation will not increase. All this will prevent us from establishing a highly efficient management system aimed at raising the basic technical-economic and operating indexes of our sector.

In our opinion, the most important decision would be to set up a head specialized scientific research and design organization for development and introduction of the Rechflot ASU at the Ministry of the River Fleet. It should be given the rights and obligations of a "single contractor" for all questions of building the ASU and all the collectives of developers of the steps and subsystems of the Rechflot ASU (TsNIIEVT, GIIVT, LIVT, NIIVT, and the Main Computing Center of the Ministry) should be subordinate to it with respect to scientific methods and for questions of planning, finances, and auditing.

There is another possible approach to solving the problem of improving the system of direction and coordination of scientific research. This would require reorganizing the work of TsNIIEVT so that it performs the functions of head institute for controlling the operation and economics of the sector, river transportation. The first thing required would be to make the specialized organizations in charge of development of the Port ASU at LIVT and the Parokhodstvo ASU at GIIVT and NIIVT subordinate to it with respect to both scientific methods and management. At the same time the efforts of the leading divisions ("Organization of Shipments and Fleet Operation," "The Economics, Organization, and Technology of Port Work," and "Economic Research") should be directed to research in the field of building automated control systems.

In our opinion, realization of these proposals will make it possible to increase the efficiency of the development and functioning of automated control systems in river transportation.

COPYRIGHT: "Rechnoy transport", 1978

SCIENTISTS AND SCIENTIFIC ORGANIZATIONS

NEW MEMBERS OF LATVIAN SSR ACADEMY OF SCIENCES PRESENTED

Riga NAUKA I TEKHNIKA in Russian No 6(215), Jun 78 pp 5-7

[Biographical sketches and appreciations of newly elected members of the Latvian SSR Academy of Sciences: "Chosen by the Academicians"]

[Text] At the annual general meeting of the Latvian SSR AN [Academy of Sciences] in March of this year, new academicians and corresponding members were elected. The following people were elected as members of the AN: Doctor of Technical Sciences M.Ye. Beker, Doctor of Medical Sciences A.F. Blyuger, People's Writer of the Latvian SSR A.P. Grigulis, Doctor of Chemical Sciences E.Yu. Gudriniyetse, and Doctor of Philosophical Sciences V.A. Shteynberg. Those chosen as corresponding members were: Doctor of Historical Sciences I.K. Apine, Doctor of Philological Sciences A.Ya. Blinkena, Doctor of Economic Sciences A.A. Kalnyn', Doctor of Chemical Sciences R.Ya. Karklin', Doctor of Chemical Sciences M.Yu. Lidak, and Doctor of Physical and Mathematical Sciences P.T. Prokof'yev.

Academician Emiliya Gudriniyetse



Biographical sketch: Emiliya Yulianovna Gudriniyetse was born in Latvia in 1920, in Kautnaskaya Volost. In 1941 she was graduated from the Rezekne Teachers' Institute, and in 1948 from the Chemistry Faculty of the Latvian State University. She was a teacher at the University, and for her synthesis of Furacilin was awarded the Latvian SSR State Prize in 1957. Since 1958 she has been working in the Chemistry Faculty of

Riga Polytechnic Institute (RPI). In 1951 she defended her dissertation for the title of candidate, and in 1960 for that of doctor of chemical sciences. She has been a professor since 1961, and was dean of the Chemistry Faculty, while from 1959 to 1961 she was RPI's prorector for science. Since 1963 she has been a corresponding member of the Latvian SSR AN. She has been the head of RPI's Department for the Technology of Fine Organic Synthesis since the day it was founded.

Appreciation (by Professor A. Strakov, RPI prorector, and I. Grosvall, RPI senior scientific worker): The circle of E.Yu. Gudriniyetse's scientific interests primarily encompasses carbonyl and heterocyclic compounds. As a result of her research, she has discovered new classes of organic compounds and synthesized many new biologically active compounds, effective growth stimulators, and original analytical reagents for producing metal ions.

E.Yu. Gudriniyetse's research in the field of the chemistry of dicarbonyl compounds is extremely original. She was the first to create methods for their sulfurization and azomethylation. As long ago as the preparation of her doctoral dissertation, a new area for research was seen: the synthesis of "heterocycles" using carbonyl compounds as the original material. Her work in this field is extraordinarily diversified and has continued to the present day. She has synthesized new derivatives of thiazole, indazole, diazepam, pyridazine, butenolide, and acridine. She has blazed new paths in the production of previously unavailable groups of compounds, contributed to the interpretation of theoretical problems in organic chemistry, and obtained solid practical results.

She has developed an original method for obtaining growing substances (ariluksusnyye [translation unknown] acids). She has made an extensive study of derivatives of carboxylic acids of the cyclobutane series, which are substances with antiviral activity, and polymer plasticizers. She also developed and introduced the antioxidant ionol, and has recently begun investigating production methods for synthesizing amino acids.

Professor E.Yu. Gudriniyetse has published 379 scientific works and received 39 patents for her discoveries. She is the co-author of the textbook "Methods of Organic Synthesis" (1976).

The Party and government value the services of Emiliya Yulianovna Gudriniyetse quite highly. In 1970 she was awarded the title of "Honored Worker in Science and Technology of the Latvian SSR," and she has also received the Orders of Lenin and the Labor Red Banner, as well as the "Badge of Honor."

Academician M.Ye. Beker



Biographical sketch: Martin Yekabovich Beker was born in Madonskiy Rayon in 1928. In 1953 he was graduated from the Food Industry Technology Faculty of the Latvian Agricultural Academy. From 1954 to 1959 he worked as a foreman and was in charge of the laboratory at the Riga Yeast Plant. From 1959 to 1962 he was chief engineer of the Design and Technological Office at the Administration of the Foodstuffs Industry of the Latvian SSR's Council of the

National Economy. In 1959 M.Ye. Beker defended his candidate's dissertation, "Accelerated Drying of Yeasts in Suspension and the Effect of Basic Little-Studied Factors on the Activity of Dried Yeasts." Since 1962 he has been the assistant director of the Latvian SSR AN's Institute of Microbiology imeni A. Kirkhenshteyn. In 1966 he defended his doctoral dissertation, "Desiccation of a Microbic Biomass." Doctor of technical sciences, professor, and laureate of the Latvian SSR State Prize, M.Ye. Beker has 75 inventions to his credit, as well as 14 foreign patents and 158 scientific publications, which include 13 monographs and pamphlets.

Appreciation (by M. Kristapson, candidate of technical sciences): The scientific activity of M.Ye. Beker and his fundamental research in the biosynthesis of physiologically active substances over a number of years are related to the accelerated development of the microbiology industry in the Soviet Union.

Academician of the Latvian SSR AN and doctor of technical sciences, Professor M.Ye. Beker is the head of a specialized council on the physiology of micro-organisms. This research was begun at the Institute of Microbiology imeni A. Kirkhenshteyn in 1964.

Under his leadership, an integrated study was made of the physiological, biochemical and structural-morphological properties of the producer of the indispensable amino acid L-lysine. The first plant in the world for the production of a fodder concentrate of lysine was built in Livany and has been operating at full capacity for less than a year. The experience of Latvian scientists and specialists is being used successfully in other Union republics, as well as in the countries of the socialist collaboration: in 1977, the production of lysine was begun at

the Shebekino Chemical Plant (RSFSR), as well as at plants in Hungary and Bulgaria.

M.Ye. Beker is the initiator of the development of a new scientific discipline -- biotechnology and bioengineering -- in Latvia, and is working on the principles of fermentation processes and the development of equipment for production lines. He is the author of "Introduction to Biotechnology," the first textbook in the USSR on this subject.

Academician A.F. Blyuger



Biographical sketch: Anatoliy Fedorovich Blyuger was born in Gaysin (Ukrainian SSR) in 1926. After finishing his schooling at the Second Moscow Medical Institute imeni N.I. Pirogov in 1951, he started working at the Riga Clinical Infection Hospital. Since 1960, A.F. Blyuger has been the prorector for scientific work and the head of the Department of Infectious Diseases at the Riga Medical Institute. He is also the scientific director of the Latvian

Hepatological Center and assistant chairman of the Latvian SSR Ministry of Health's Scientific Medical Council. Doctor of medical sciences, professor, and laureate of the Latvian SSR State Prize, A.F. Blyuger is the author of 350 works on questions of clinical biochemistry and the morphology, immunology and chemotherapy of infectious diseases and diseases of the liver, including 21 books and 20 patents for inventions.

Appreciation (by V. Rubtsov, MEDICAL NEWS's correspondent for the Soviet Pre-Baltic republics): A.F. Blyuger is one of this country's leading scientists in the field of infectious pathology and hepatology and has added to our scientific knowledge with works of great theoretical and practical value. In 1961 he founded the Latvian SSR Hepatological Center and the first problems laboratory of clinical biochemistry of infectious diseases in this country, where systematic work was begun on the problem of viral hepatitis and its origins.

A.F. Blyuger is one of the USSR's pioneers in the development of live morphological studies of the liver. The needle for puncture biopsy of the liver that he modified, as well as the method itself, has been introduced at 80 clinics in our country. He has comprehensively developed both the theory and

practice of a method for the complex structural-functional analysis of the pathological process in the liver and, on the basis of newly obtained data, wrote the widely known monograph "Structure and Function of the Liver During Botkin's Disease" (1964). Other large contributions to the development of hepatology were his monograph "Viral Hepatitis and Its Origins" (1970) and the collection of works "Principles of Hepatology" (1975), which he edited.

Data obtained by A.F. Blyuger were the basis for morphological substantiations of the enteral phase of the pathogenesis of dysentery, salmonella and viral hepatitis. He developed a hypothesis on the mechanism of giperfermentemiya [translation unknown] during pathological processes, investigated the pathogenesis of a new class of liver diseases (hereditary pigment hepatoses), and proposed the classification of jaundices that is recognized in our country.

The methods for diagnosing and prognosing infectious and liver diseases that were developed by A.F. Blyuger and his coworkers are protected by 20 patents for inventions.

A.F. Blyuger's scientific creativity has been continuously related to the training and education of young people. Under his leadership, 14 doctoral and 35 candidates' dissertations have been prepared and a widely recognized scientific school of infectious hepatologists has emerged.

The scientific, pedagogical and public activities of A.F. Blyuger are highly valued by the Party and the government. He has been awarded to Order of the Labor Red Banner, the "Badge of Merit," and diplomas from the Presidium of the Latvian SSR's Supreme Soviet, and holds the title of Honored Scientist of the Latvian SSR.

Academician V.A. Shteynberg

Biographical sketch: Valentin Avgustovich Shteynberg was born in Odesskaya Oblast in 1915. In 1945 he was assistant chief of the Administrative Division of the Latvian Railway. From 1946 to 1948 he was the assistant manager of the Propaganda and Agitation Section of the Latvian Komsomol's Central Committee. In 1947 he was graduated from the Higher Party School of the Central Committee of the All-Union Communist Party (of Bolsheviks). In 1952 he became the docent and head of the Department of Marxism-Leninism at Riga Pedagogical Institute. He defended his dissertation in the competition for the scientific degree of doctor of philosophical sciences in 1961, and received the title of professor. From 1962 to 1970 he was rector of the Latvian State University imeni P. Stuchka. At the present time



he is the director of the Latvian SSR AN's History Institute. He has been awarded two Orders of the Labor Red Banner and the "Badge of Merit."

Appreciation (by Ya. Veysh, head of the Sector for Criticism of Modern Bourgeois Ideology, History Institute, Latvian SSR AN): Valentin Avgustovich Shteynberg is one of the leading philosophers in our republic. His scientific, social-political and organizational

activities are closely related to the development of Marxist-Leninist theory.

V.A. Shteynberg's research, in which he has analyzed and studied the history of social-political thought in Latvia from the Marxist viewpoint, has made a large contribution to the science and culture of Soviet Latvia. This question is the subject of his own monographs and many collections of scientific works and essays that he has edited. In different periods of his creativity, V.A. Shteynberg turned to the criticism of modern anti-communism and bourgeois ideology and investigated the urgent problems of historical materialism and sociological problems. He actively participated in various all-union and international forums of philosophers and sociologists. V.A. Shteynberg is a tireless teacher: generations of students attended and were educated by his lectures on philosophy at the Riga Pedagogical Institute and the Latvian State University.

Academician V.A. Shteynberg is well known as a social and political worker. He is a member of the CC CP of Latvia and a deputy of the Latvian SSR's Supreme Soviet. Other achievements worthy of mention are his activities on the board of the Republic's Znaniye Society and as chairman of the Latvian Division of the USSR Philosophical Society.

Academician A.P. Grigulis

Biographical sketch: Arvid Petrovich Grigulis was born in Latvia in 1906, in Ladskaya Volost. In 1937 he was graduated from the National Economy and Legal Sciences Faculty of the University of Latvia. During the Great Patriotic War he was a radio operator and military correspondent for the front-line newspaper LATVIYESHU STRELNIYEKS. In 1954 he became a teacher at the Latvian State University. From 1948 to 1952 he was head of

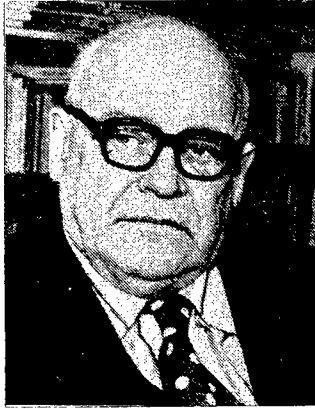

the Department of Lettish Literature at LGU [Latvian State University], after which he worked as the chief script editor at the Riga film studio. Since 1969 he has been a teacher in LGU's Department of Journalism.

A.P. Grigulis is an Honored Cultural Worker and People's Writer of the Latvian SSR and has been awarded two Orders of the Labor Red Banner and two "Badges of Merit."

Appreciation (by M. Leyyete, head, Department of Journalism, Philological Faculty, LGU imeni P. Stuchka): In the field of Lettish Literature, A.P. Grigulis occupies a dual position as both author and investigator. It would be difficult to imagine our postwar literature without his stories, plays and verse. "Through Fire and Water," "Lilac Branches," "Clay and Porcelain" -- every reader will find things of true value in these works. I dare say that they belong to the classic of Lettish literature.

Our relationship to our literary heritage, Lettish literature as an organic part of the multinational Soviet literature, internationalism as the principle of artistic creation, the connections between Russian and Lettish literature -- these are subjects to which specialist in literature A.P. Grigulis has devoted many articles that have been published in books, magazines and newspapers, as well as many speeches and reports given at congresses and conferences.

Textbooks have been written on his initiative and with his participation. His lectures are popular far beyond the bounds of VUZ walls, since they expound on important problems in modern esthetics and are rich in philosophical conclusion and propositions. Professor Grigulis is not afraid to enter in polemics -- arguing scientifically, he defends his position with civil fervor. All of his activities are permeated with the true spirit of scientific boldness and the principles of a true communist.

He teaches a course in the history of Latvian journalism. At the present time he is preparing another course, in literary criticism. "Lettish Literary Criticism" is a fundamental collection of works, in six volumes, that was written because of his initiative and under his guidance. It could serve as an "entire life's work," but is only a part of his output.

His lecture course, "History of Lettish Journalism," is undoubtedly capital research. However, its preparation for publication has been continually delayed by other activities: the writing of a book on Andrey Upit, chapters in a book on the history of Lettish literature, and so forth. However, it may be that this is the most characteristic feature of a true scientist: to do precisely that work that a society most needs at a given moment.

COPYRIGHT: Izdatel'stvo TsK KP Latvii, "Nauka i Tekhnika,"
1978

11746
CSO: 1870

SCIENTISTS AND SCIENTIFIC ORGANIZATIONS

DIGITAL ELECTRONIC METROLOGY EXPERT V.M. SHLYANDIN HAILED

Moscow PRIBORY I SISTEMY UPRAVLENIYA in Russian No 5, 1978 p 31

[Article: "Our Birthday Greetings"]

[Text] RSFSR Honored Figure in Science and Engineering, Doctor of Technical Sciences, Professor Viktor Mikhaylovich Shlyandin has reached his 60th birthday.

Viktor Mikhaylovich has traveled a long creative path from engineer to well-known scientist and teacher and one of the founders of domestic digital electronic measuring technology.

Working at different periods in his life at instrument making enterprises in Moscow, and involved in teaching and scientific work, Viktor Mikhaylovich Shlyandin has devoted and is devoting a great deal of time and effort to the training of scientific personnel and to the education of highly skilled instrument making specialists.

Viktor Mikhaylovich is widely known in the Soviet Union and abroad as one of the leading scientists in the field of automation of electrical measurements and of digital measurement technology. He is author and coauthor of more than 500 scientific works, including 11 monographs.

V.M. Shlyandin created a scientific training center which has won recognition and enjoys great authority in our country. He is the organizer and director of an industrial scientific research laboratory of automation of electrical measurements and testing, which has been deservedly acknowledged as one of the leading science centers in the field of electronic instrument making and measurement technology. More than 30 candidate's and two doctoral dissertations have been prepared and written under his guidance.

Viktor Mikhaylovich has successfully combined his scientific and teaching work with public scientific activities. He is the chairman of the Penza territorial group of the USSR Academy of Sciences and chairman of the expert commission on instrument making and computer technology of the Volga regional scientific and technical council of the USSR Ministry of Higher and

Specialized Education and also takes part in the work of a number of other public scientific organizations.



On his birthday the chairman of the department of measuring and information technology of Penza Polytechnical Institute, Professor V.M. Shlyandin, is at the prime of his creative powers and is full of new ideas and plans. We wholeheartedly wish him good health and new creative successes.

COPYRIGHT: Izdatel'stvo "Mashinostroyeniye", "Pribory i sistemy upravleniya",
1978

8831
CSO: 1870

SCIENTISTS AND SCIENTIFIC ORGANIZATIONS

SCIENTIFIC INSTRUMENT MAKING PRODUCT IDENTIFICATION APPROACH DISCUSSED

Moscow PRIBORY I SISTEMY UPRAVLENIYA in Russian No 5, 1978 p 46

[Article by A.P. Pakhomov, engineer: "One Approach to Segregating the Products and Subindustry of Scientific Instrument Making"]

[Text] Successful planning, monitoring and record keeping of the output of instruments for scientific investigations are impossible without taking into account the specifics of both the products produced by the scientific instrument making industry and the place of the scientific instrument making industry in the industry of producing instruments and automation equipment.

The products of the scientific instrument making industry are determined in industry and restricted by an approved nomenclature for a planned period [1]. In drawing up the nomenclature use is made of the principle of classification, which takes into account purpose, applicability, and the instrument method of research to be implemented with instruments. Similar groupings of instruments for scientific research are used in foreign statistical summaries [2].

The generally used designation "instruments for scientific research" in itself suggests that the specifics should be found by analyzing the purpose and applicability of products [3]. Unfortunately, the criterion "for primary application in the process of a scientific research experiment" [4] has had no major effect in practice. Let us consider some reasons for this lack of success.

The actual total demand of industry for instruments based on the latest methods of measurement is greater than the demand of science for them. "The level of modern technology is such that many instruments developed for research needs begin in fact, without any modifications of any kind, to be used directly for practical purposes, and frequently with enormous savings" [5]. This phenomenon is reflected in the similarity of the majority of designations of groupings under "Nomenclature of Key Types of Instruments for Scientific Research" to the groupings of class 42 and 43 of the All-Union Products Classifier (OKP). It should be taken into account that a significant portion of experimental research in science is of a repetitious routine

nature. The method of employing instruments and the actual consumer demand for them are in this case similar to the employment and demand for instruments of a general industrial application, and, however, certain errors produced by "dual applicability" [3] can be avoided in analysis. For example, the phrase frequently encountered in catalog descriptions, "instrument designed for (a listing of industrial applications follows)..., as well as for scientific research" as a matter of fact clearly indicates the second, since an instrument used in investigations for developing new materials, equipment, or a technology must of course have a margin of technical capabilities, as compared to an instrument designed to monitor a developed process or product [4].

An instrument designed for scientific research, in spite of its redundancy, is suitable for industrial applications. The reverse is usually not true, since a special-purpose instrument for an industrial application, although the method of measurement used is a general one, has specific technical characteristics. Moreover, the method of comparative rating according to single indicators of purpose used in [6] does not produce a quantitative parametric criterion for the membership of a product among instruments for scientific research. It is necessary to work out an overall technical and economic indicator of purpose and a method of breaking it down for compatibility with the existing system.

The algorithm for the functioning of instruments for scientific research can probably not be expressed through a single function of the type "measurement of a magnitude" or "conversion of a form of information." The range of their functional capabilities should be characterized by an ability to obtain multidimensional relationships during indirect measurement, and this aspect must be expressed in formulation of their purpose.

Thus, the problem of determining the specifics of products of the scientific instrument making industry can be reduced to segregating instruments for scientific research within the groupings put together for instruments and automation equipment for general industrial and special purposes by means of analyzing indicators of purpose and applicability.

Based on this approach, in 1976 VNIInauchpribor [All-Union Scientific Research Institute of Scientific Instrumentation] (Leningrad), with the participation of NIIstandartpribor [Scientific Research Institute of Standardization of Instrumentation] (Moscow) and VNIPI OASU [All-Union Scientific Research and Planning Institute of Industrial Automated Control Systems] (Moscow), developed "Nomenclature of Key Types of Instruments for Scientific Research in Keeping with the Profile of Minpribor [Ministry of Instrument Making, Automation Equipment and Control Systems]" and "Instructions for Classifying Instrument Making Products under OKP Major Classification Grouping 420900--Instruments for Scientific Research." Based on these instructions, instruments for scientific research are segregated within general industrial groupings and are coded with the digit "nine" in the seventh and eighth digits of the 10-digit OKP code, and all nomenclature in the set has been assigned the collective grouping code 420900. This method of recording and grouping products

is also a good reflection of the specific nature of the place of scientific instrument making within the industry.

The approach to instruments for scientific research as part of the combined products of the instrument making industry has resulted in the addition in 1976 of a new reporting index--the percentage of instruments for scientific research in terms of total production. But this new index has proven to be inflexible with regard to the rapid variability in demand (in terms of quality and quantity) for different groups of instruments for scientific research, and any attempt to organize planning and accounting in terms of this index is incompatible with existing systems. As of 1977 this index has been replaced by an absolute one. Instruments for scientific research have been given a separate line on the plan.

Instruments for scientific research are made, because of the variability in demand (and nomenclature), in each planning period by a variable number of enterprises and even of all-Union industrial associations. The load is redistributed among associations, and the percentage of scientific instrument making products at different plants equals from fractions of a percent to 70 percent. In this situation planning production in terms of the entire group of technical and economic indicators is exceedingly difficult, and the development of a compatible system of planning and controlling the scientific instrument making industry has met with not a few obstacles in its path.

The choice of the approach to segregating products of the scientific instrument making industry described in this article makes it possible to formulate an approach to defining scientific instrument making as a part of the instrument making industry: Scientific instrument making is a hypothetical collective subindustry which produces products with uniformity of purpose and groups for this purpose enterprises and scientific research and technology and design organizations which do work on creating instruments for scientific research as part of their capacities.

BIBLIOGRAPHY

1. Orlov, V.A., Ozherel'yev, A.Ya., et al. "Scientific Instrument Making in the Ninth Five-Year Plan Period," PRIBORY I SISTEMY UPRAVLENIYA, No 2, 1976.
2. "Sales Markets for the USA Electronics Industry in 1975," ELEKTRONIKA, Vol 48, No 1, 1975.
3. Kontorovich, F.S. "Scientific Instruments," PRIBORY I SISTEMY UPRAVLENIYA, No 7, 1976.
4. "Problemy razvitiya nauchnogo priborostroyeniya v SSSR" [Problems in Development of Scientific Instrument Making in the USSR], collection of articles, ONTIpribor, Moscow, 1966.

5. Fedoseyev, N.P. "Decisions of the 25th CPSU Congress and Goals of the USSR Academy of Sciences," VESTNIK AN SSSR, No 9, 1976.
6. GOST [All-Union State Standard] 2.116-71 YeSKD. Chart of Technical Level and Product Quality.
7. "Metodicheskiye ukazaniya k razrabotke gosudarstvennykh planov razvitiya narodnogo khozyaystva SSSR" [Methodological Instructions for Development of State Plans for Development of the USSR's National Economy], Moscow, Ekonomika, 1974.

COPYRIGHT: Izdatel'stvo "Mashinostroyeniye", "Pribory i sistemy upravleniya", 1978.

8831

CSO: 1870

SCIENTISTS AND SCIENTIFIC ORGANIZATIONS

PRODUCTION OF EXPERIMENTAL MODELS OF COMPLEX INSTRUMENTS IMPROVED

Moscow PRIBORY I SISTEMY UPRAVLENIYA in Russian No 5, 1978 p 47

[Article by D.F. Guz', I.I. Gut and A.I. Kukhlevskiy, engineers: "Organizing the Production of Experimental Models of Products Under Conditions of a Scientific Production Association"]

[Text] One of the major objectives set for science and industry by the 24th CPSU Congress has been to reduce the time required for creating and putting into service new equipment. This problem has been solved successfully at our enterprise by making experimental models of complicated instruments under conditions of a scientific production association (NPO).

A scientific production association is characterized by high-level specialization and concentration of production, creating the prerequisites for raising the technical level of plant shops and sections. In addition, in designing items of new equipment of great importance are the use of a great number of parts and units whose production has been mastered, unification, and standardization, which is conducive to standardization of technological processes. Utilization of these factors to a considerable extent reduces the time needed for preparing for production and for making parts and units for products [2].

But in making experimental models of complicated instruments under conditions of an NPO of great importance is the proper organization of work both in the experimental production (OP) sections of the NII [scientific research institute] or KB [design bureau] and in the individual shops of the association's plants.

An NII and KB as a rule do not have at their disposal large-capacity production centers, which does not make it possible quickly to make a great number of parts and units [1]. Therefore, for purposes of timely fabrication of experimental models of instruments on the scale of an NPO the entire program for production of parts and units was divided between the NII and plants: The NII was assigned 30 to 40 percent and plant shops 60 to 70 percent of the program. In addition, to reduce the time required to make experimental models in the NPO, steady work has been done on finding measures aimed at shortening the time required for designing and making experimental models of complicated

instruments. Taking part in the development and implementation of measures are also the services of the chief production engineer and chief designer and economic planning and production subdivisions of the NII and plants of the NPO.

The foundation of these measures is as follows:

Designing instruments to take into account all existing standards of the enterprise, while using parts and units whose production has been mastered, with a high degree of unification and standardization; coordinating design documentation (KD) with the services of the head plant at the stage of its development; timely transfer and receipt of technical documentation for preparing for production; efficient preparation for production; timely furnishing of materials and equipment; creation of a combined group for setting up the production of parts and units; financing and estimates. These functions are explained below.

Coordinating KD with representatives of services of the head plant makes it possible before releasing the product for production to solve many problems relating to preparation for production and to determine the feasibility of making parts and units under conditions of an NPO. The coordinated KD is relayed in kit form in the necessary number of copies. The copied KD, the holder of the originals of which is the head plant, is reproduced and collated by the division of technical documentation (TD) of the head plant. All documentation bears a standard order number. In addition to the KD kit, services of the NPO are sent the following documentation.

1. Specifications for production process routing (SpTM), on tracing paper without plotting production process routes. In the "Remarks" column, products to be received by the customer are indicated by the index "PZ," and products whose series production has been adopted by the head plant, by the index "IZI." Parts previously released for production should have a reference in the "Remarks" column to the specific document sent to production (SpTM, route sheet, official memorandum, etc.).
2. A detailed standard list of materials on tracing paper and coordinated with the NII's materials and equipment supply division.

Upon receipt of the TD by the individuals responsible, a check is made of its completeness, of the quality of the copies, and for the presence of the required signatures. Incorrectly formed documentation is returned to the TD division of the NII for elimination of the faults found or for replacement.

After all services of the NPO have been furnished with the necessary TD, the key production subdivisions begin to prepare for production of the product's parts and units. Here technological processes are as a rule not developed by the plant. For especially complex parts and units route-type technological processes are mapped out in the technological bureaus of shops, under the discretion of the chief production process engineer's division of the NPO. New

technological processes are developed and relayed by the chief production process engineer's division of the NII. Design documentation for products whose fabrication requires special equipment (compression molding, casting, drop forging, etc.) is forwarded for preparation for production in good time (depending on the complexity of the equipment) with a separate SpTM and with a production preparation sheet drawn up. Standard, standardized, and copied parts and units whose series production has been mastered at the head plant are supplied by it.

All original parts and units are separated into two groups. To the first belong parts and units whose frequency of use is greater than 25 units. Their fabrication is planned in shops of the NPO's plants. Here extensive use is made of general-purpose equipment and devices, because of which the number of units of equipment has been reduced drastically (as compared with NII OP).

So, in fabrication of parts and units for a single product plans were made to fabricate 30 to 40 and 60 to 70 percent of parts and units and 35 and nine units of equipment at the NII and NPO plant shops, respectively.

As is obvious from the data given, the number of units of equipment necessary for shops of the association's plants has been reduced almost fourfold, as compared with NII OP. The parts and units sent to NPO plant shops for production make up 60 to 70 percent. The remaining 30 to 40 percent of parts and units, which number less than 25 units each in terms of frequency of use, come under the second group, and their fabrication is planned for NII OP. This separation of parts and units makes it possible to fabricate parts of the first and second group simultaneously and shortens the time required for manufacture by a factor of 1.5 to two.

At the same time as TD is forwarded and the required materials are supplied, an order is issued for creation of a combined group for organizing the production of parts and units for the specific product; the main objectives of this group are as follows: to make make production schedules for fabrication of parts and units; to hold efficiency technique meetings aimed at timely fabrication of the product; production control; solution of design and technology problems; receipt of finished products and delivery to the warehouse of finished NII products.

One of the leading engineers for the product developed is designated the director of the combined group. The group is made up, as a rule, of designers and development engineers (three to four individuals), production controllers (three to four), production process engineers (one or two), representatives of materials and equipment and outfitting divisions, and also OTK [equipment design division] personnel.

Relative financial estimates for the NII and NPO plants are made according to agreement. To the agreement is attached a list of equipment and units to be made at NPO plants. Cost accounting for their fabrication is coordinated

with a representative of the NII as documentation arrives and serves as the basis for estimates.

Consequently, the NPO, carrying out measures for concentration and specialization of production, steadily raising its technical level, and improving standardization and unification of production processes in light of the decree of the CPSU Central Committee and the USSR Council of Ministers regarding increasing the role of standards in improvement of the quality of products put out, has been reaching a faster and better solution to problems relating to fabrication of experimental models of complicated instruments than has the OP of NII's and KB's, while shortening considerably the research-production step.

BIBLIOGRAPHY

1. Bashin, M.L. "Khozyaystvennyy raschet v otraslevykh NII i KB" [Cost Accounting in Industrial NII's and KB's], Moscow, Moskovskiy rabochiy, 1971.
2. Kochevykh, I.P. and Semenov, O.M. "Problemy, poiski, resheniya" [Problems, Research and Solutions], L'vov, Kamenyar, 1973.

COPYRIGHT: Izdatel'stvo "Mashinostroyeniye", "Pribory i sistemy upravleniya", 1978

8831

CSO: 1870

SCIENTISTS AND SCIENTIFIC ORGANIZATIONS

MEASURING AND INFORMATION SYSTEMS CONFERENCE, BAKU 1977, REVIEWED

Moscow PRIBORY I SISTEMY UPRAVLENIYA in Russian No 5, 1978 pp 55-58

[Article by the Organization Committee: "IIS-77"]

[Text] From 15 to 17 November 1977 in Baku, at the Azerbaydzhan Order of the Red Banner of Labor Institute of Petroleum and Chemistry imeni M. Azizbekov, was held the "IIS-77" all-Union conference on measuring and information systems. Conferences on problems relating to measurement have, perhaps, very deep roots in the domestic instrument making industry, since they were first held by K.B. Karandeyev, when each spring instrument makers from the entire country convened at the USSR Academy of Sciences Siberian Division Academy Campus at the Institute of Automation and Electrometry.

These conferences, originated and supported by the wide engineering and scientific public of instrument makers, are now held regularly (once every other year) in various advanced instrument making towns in the country and, in keeping with the major subject matter of the theory and practice of modern instrument making, are called "IIS" [measuring and information system] conferences. The chief organizer of the conference on IIS's is the USSR Academy of Sciences Scientific Council on Problems of Electrical Measurements and IIS's. The Baku conference was held by this scientific council in conjunction with the Ministry of Instrument Making, Automation Equipment and Control Systems, the Azerbaydzhan SSR Academy of Sciences, the Azerbaydzhan SSR Ministry of Higher and Secondary Special Education, the Azerbaydzhan Institute of Petroleum and Chemistry imeni M. Azizbekov, and the Azerbaydzhan Republic Administration of the Scientific and Technical Society of the Instrument Making Industry imeni Academician S.I. Vavilov.

Extensive advances and the application of IIS's in various industries of the national economy were responsible beforehand for great interest in the Baku conference. Taking part in the proceedings of the conference were about 700 specialists, including 33 doctors of science and 240 candidates, representing more than 170 organizations from 45 cities. Discussed at the meetings were 278 papers and reports, and two roundtable discussions were held. The conference devoted special attention to new trends in the development of IIS's: to problems relating to the theory and practice of computing and measuring

complexes (IVK's) and to the application of microprocessors in IIS's; to metrological hardware for IIS's; to further advances in methods of automatic error correction in IIS's; and to the development of IIS's for problems relating to environmental protection.

Papers were delivered on precisely these key trends at the full meetings: "Computing and Measuring Complexes" by USSR Deputy Minister of Instrument Making, Automation Equipment and Control Systems, Doctor of Technical Sciences G.I. Kavalero; "Practical Questions Relating to Environmental Protection" (with the Azerbaydzhan SSR as an example) by First Deputy Chairman of the Azerbaydzhan SSR Council of Ministers, Corresponding Member of the Azerbaydzhan Academy of Sciences, Doctor of Technical Sciences I.A. Ibragimov; "Interfaces in IVK's--Diversity and Unity" by Doctor of Technical Sciences S.M. Mandel'shtam (Leningrad); "Methods of Automatic Correction of Errors in IIS's" by Doctor of Technical Sciences T.M. Aliyev (Baku); "International System of Small Computers" by Corresponding Member of the USSR Academy of Sciences, Doctor of Technical Sciences B.N. Naumov (Moscow); "Metrological Hardware for Information and Measuring Systems" by engineers Ye.T. Udovichenko, A.D. Pinchevskiy and E.S. Brailov (L'vov); and "Microprocessors in IIS's" by Candidate in Technical Sciences V.I. Vinogradov (Moscow). Here it is apropos to mention that the materials of a number of full reports were first published on the pages of our journal [1,2].

At work at the conference were nine sections and two subsections. Great attention of the participants was attracted by the topics and reports of the section on theoretical fundamentals of IIS's (chairmen, doctors of technical sciences M.P. Tsapenko and P.P. Ornatskiy). Present at its meetings were as many as 150 specialists, and 17 papers and reports were read.

The general topics of these papers were concerned mainly with a discussion of standard interfaces, with theoretical research and problems of designing IIS's, and with metrological hardware for IIS's.

Devoted to problems of interfaces in IIS's were a paper by E.I. Tsvetkov, G.S. Pevzner and M.B. Tsodikov (Leningrad), "Information Compatibility of the Hardware of a Standard-Unit Combination of Electronic Measuring Equipment," the abovementioned full report by S.M. Mandel'shtam, and a report by M.P. Tsapenko (Novosibirsk), "On IIS Interfaces." Special interest was evoked by the report by Doctor of Technical Sciences M.P. Tsapenko, which gave rise to a discussion on interfaces in the section. An article on the theme of this report will be published in the next few issues of this journal, in conjunction with other articles on this topic from the materials of the conference.

The majority of the section's papers and reports were devoted to problems relating to theoretical research and design of IIS's. Of special interest among them were the following papers: that of T.M. Askerov and E.B. Aliyev (Baku), in which the authors dealt with one of the new problems in contraction of binary information; that of Sh.Yu. Ismailov, N.F. Sysoyev and K.V. Tyulenev (Leningrad), devoted to the synthesis of structures of multichannel measuring

sources of Gaussian random processes and to the results of practical development of such sources; that of A.N. Yefimov and V.M. Kuteyev (Khar'kov), which dealt with the feasibility of using for measurement the method of rank statistics with a known law of distribution of probabilities of the measured magnitude; and that of S.M. Persin (Leningrad), in which the author made a quite profound analysis of methods of measuring and estimating extremum characteristics of random processes and fields.

O.N. Novoselov and A.F. Fomin (Moscow) presented a summary of results of a great amount of research in the important area of increasing the certainty of estimates and of enhancing the noise rejection of digital measuring systems. In a paper by E.I. Tsvetkov, G.S. Pevzner, M.B. Tsodikov and G.Z. Shcherbakovskiy (Leningrad), the attention of the participants was attracted by models of some electronic measuring equipment hardware and by questions relating to implementing the results arrived at in a standard-unit ASET [automated system of electronic equipment] complex. A report by N.A. Mamedov (Baku) was devoted to the urgent problem of designing man-and-machine IIS's.

A group of papers was devoted to metrological hardware for IIS's. Among these mention should be made of papers by M.A. Zemel'man and V.N. Kuznetsov (Moscow), which dealt with fundamental problems in regulating the metrological characteristics of measuring systems and gave some recommendations; and by D.A. Konovalov and G.N. Solopchenko (Leningrad), which discussed aspects of the metrological hardware of IVK's. P.V. Novitskiy (Leningrad) proved the feasibility of utilizing the computer included in the IVK to determine the running degree of error in this complex.

Taking part in the proceedings of the section "IIS's in the Oil and Gas Industry" (chairmen, doctors of technical sciences T.M. Aliyev and G.A. Shtamberger) were 123 specialists, and 27 papers and reports were heard. An especially large number of papers were devoted to research and development of IIS's to monitor sinking processes and the parameters of turbulent oil and gas wells and to monitor the process cycles of wells in operation.

Discussion of the papers and reports and the exchange of opinions between participants at the meetings showed that the following are the most crucial and important problems in further development of IIS's in the petroleum and gas industry: creation of IVK's for automation of control of the operation of wells with a mechanized method of oil recovery; development of the fundamentals of the structure of IIS's for monitoring depth processes in wells and application of the results of this development in creating ASU TP's [automated systems for controlling technological processes] for drilling and oil recovery; and further development and organization of series production of sensors with a digital output signal and enhanced metrological and technical and economic characteristics for obtaining primary information on the processes of drilling wells and recovering oil and gas.

Fourteen papers were delivered in the section "IIS's in Petroleum Refining, Petrochemistry and Power Engineering" (chairmen, doctors of technical sciences B.V. Vol'ter and R.A. Aliyev). As a result of discussion of them,

the necessity was revealed of speeding up work on creating sparkproof equipment for linking with the controlled process which is needed for IIS's in oil refining, petrochemistry and chemistry, and of extending work on creating analytical instruments for measuring the quality indicators of technological processes in these industries.

Sixteen papers and reports were heard in the section "Automated Systems for Controlling Product Quality in Machine Building" (chairmen, doctors of technical sciences Ye.I. Krinetskiy and I.F. Klistorin). In these papers were reflected both theoretical questions relating to the structure of automated systems for controlling product quality and questions relating to their implementation.

A considerable part of the systems serving as the subject of this report have already been put into service in production and have produced considerable savings. Noted as the best papers were the following: "Automation of the Process of Monitoring Dynamic Systems" by Ye.I. Krinetskiy, V.M. Sirits and S.M. Fedorenko (Moscow); "Information and Measuring System for Monitoring the Operating Parameters of Internal Combustion Engines" by I.P. Polkanov and G.A. Konyukhov (Ul'yanovsk); "Automated System for Multiparametric Monitoring of Gas Turbine Engines" by L.M. Korabel'nikov et al. (Moscow); and "Automated System for Testing and Diagnosing Digital Systems" by K.Sh. Ibragimov, I.F. Klistorin, A.Ye. Podzin and S.A. Rotar' (Kishinev); etc. [3].

Papers in the section "Computing and Measuring Systems for Automation of Scientific Experimentation" (chairmen, doctors of technical sciences A.M. Melik-Shakhnazarov and S.M. Mandel'shtam) were concerned mainly with three main topics. The first of these was general questions relating to the structure of IVK's and their software. Of special interest here were the following reports: "Standard Software for IVK's based on minicomputers and ASET hardware for Scientific Research" by A.I. Belyavskiy, S.M. Mandel'shtam, et al. (Leningrad); and "Expansion of Systems Software for Mini- and Micro-computers Operating in a System for Automation of Scientific Experimentation" by V.I. Saprykin, V.I. Pustovarov and V.I. Salapatov (Kiev). The second topic was diagnosis, testing, and checking of measuring equipment, machines and machinery. The following are the more important of the papers on this topic: "Means of Describing Digital Circuits in a Diagnosis System" by I.F. Klistorin, I.Kh. Koren' and A.Ye. Podzin (Kishinev); "Principles of the Structure of Computing and Measuring Systems for In-Operation Testing of Depletion of the Safe Life of Machines and Machinery" by Sh.Yu. Ismailov et al. (Leningrad); and "Automated Testing Complex" by M.S. Roytman et al. (Tomsk). The third topic of this section was the automation of scientific experimentation in the oil industry, the best papers on which were the following: "1000-Channel Computing and Measuring Complex for Investigation of Complex Technological Processes" by D.I. Damirov et al. (Baku); "Automated Systems for Studying the Composition of Multicomponent Substances" by L.V. Ilyasov (Baku); and "Automated System for Controlling a Laboratory Chemistry Experiment" by R.M. Kasimov et al. (Baku).

Forty-three papers and reports were delivered in the section "Primary Measuring Converters" (chairmen, doctors of technical sciences D.I. Ageykin

and A.A. Ter-Khachaturov). Eight of them were recommended for publication in central science and engineering journals: "Adaptive Testing Primary Measuring Converters" by E.M. Bromberg and K.L. Kulinovskiy (Kuybyshev); "Principles of the Structure of Converters of Output Values of Parametric Sensors Which Are Invariant with Respect to the Noninformative Parameters of These Sensors" by A.I. Martyashin, B.L. Svistunov and V.M. Shlyandin (Penza); "Employment of Nonuniform Long Lines for Non-Contact Measurement of Some Non-Electrical Magnitudes" by V.A. Viktorov and B.V. Lunkin (Moscow); "Linearity of Primary Converters of the Differential Type as a Function of Their Loading Cycle" by L.M. Osmolovskiy (Groznyy); "Magnetoelastic Converters (MUP's) for Measuring Force (0.1 N to 5 kN) and Prospects for Their Use in Petrochemistry" by M.N. Gumanyuk and V.M. Beskorovaynyy (Kiev); "Investigation of a Parametric Converter of Linear and Angular Displacement for IIS's for Monitoring Drilling Parameters" by T.I. Ibragima-zade, T.A. Kasimov and A.A. Ragimov (Baku); "Weighing-Type Density Converter for IIS's" by V.V. Rybakov et al. (Groznyy); and "Portable Magnetoelastic Dynamometer for Deep-Well Insert Pumps" by M.F. Zaripov et al. (Ufa). This section mentioned the need for extending work on metrological hardware for sensors and on researching new physical effects to design sensors on their basis.

Nine papers and reports were heard in the section "Methods and Equipment for Representing, Recording and Storing Information in IIS's" (chairmen, doctors of technical sciences Sh.Yu. Ismailov and V.M. Shlyandin). Three papers were recommended for publication: "Color Graphic Symbol Display for Representing Information in an IIS" by T.M. Aliyev, D.I. Vigdorov, et al. (Baku); "Structure and Principles of the Design of a Display System Based on a Standard TV Receiver for IIS's" by I.N. Maydel'man, K.A. Sarkisov, et al. (Moscow and Baku); and "Apparatus for Selection, Representation and Recording of Classification Traits of Graphic Information Obtained in Scientific Experiments" by R.G. Dzhagunov, G.S. Vaysman and R.K. Mamedov (Baku).

Two roundtable meetings were held in the course of the conference. In the first there was a discussion of topics in the science and engineering journals IZMERITEL'NAYA TEKHNIKA and PRIBORY I SISTEMY UPRAVLENIYA and the collection IZMERENIYA, KONTROL', AVTOMATIZATSIYA [4], and in the second a discussion of the problem of development of IIS's in the oil industry.

The recommendations obtained as the result of the work of the conference's sections formed the basis of its judgement.

In its judgement the conference stated that during recent years considerable progress has been achieved in the field of IIS theory (optimization of the structures of systems, systems with a variable structure, methods of structural redundancy for automatic correction of integral errors of systems, etc.) and of the practical design of IVK's, in the creation of interfaces for individual standard-unit measuring complexes, etc., and in the development of methods and systems ensuring high metrological characteristics for processes of measuring under static and dynamic conditions, and of methods of total automatic processing of measuring information with a computer.

At the same time the conference noted that in recent years attention has slackened with regard to methods of converting primary information on the basis of new principles and physical phenomena, and insufficient attention has been paid to the development of the theory of and to the metrological software and hardware for IVK's. In the papers and reports delivered there was little elucidation of problems relating to using GOST [All-Union State Standard] 8.009-72 for normalized metrological characteristics of measuring equipment. A definite lag was noted in the development, unification and application of interfaces for different levels of IIS's.

In connection with the organization of the production of IVK's at industrial enterprises the need has arisen of creating a program for standardization of IVK's (including metrological hardware and software) within the framework of the Unified System of Standardization for Instrument Making (YeSSP).

The conference resolved the following: 1. To regard the following trends as the most crucial and important in the area of the development of the theory and practice of IIS's and to recommend that scientific research and planning organizations take them into account: development of the theoretical fundamentals, structures, metrological hardware and software, and standardization of IVK's; development of interfaces for standard-unit measuring complexes, as well as the solution in the immediate future of problems relating to the use of standard interfaces in IIS's and especially in IVK's, and in this connection to extend research in the area of standard interfaces for both instruments and machines; the development of methods of converting information on the basis of new structural principles and physical phenomena; intensification of scientific studies in the area of methods of estimating errors in IIS's and of errors in measurements made by means of IIS's (here it is desirable to create criteria for the accuracy of data processing algorithms compatible with the criteria for estimating the accuracy of measurement equipment, and to classify algorithms for processing measurement results adequate for measurement objectives and goals, and to develop recommendations on the preferred variants of software for IIS's which yield high measurement accuracy); the creation of programs for standardization of IVK's within the framework of the YeSSP; further development of studies on creating facilities for automating metrological tests of instruments and systems and on automating the design of measuring equipment and, in particular, of equipment utilizing microprocessors and microcomputers; creation within standard-unit combinations of GSP's [group conversion systems] of additional units making it possible to use more effectively existing instruments and equipment in conjunction with a computer (e.g., group normalizing converters and reference signal generators and converters of parameters of resistors into active values); organization and development of an all-Union bank of standard programs for processing measurement results and for planning measuring experiments; and automation of programming.

2. To regard one of the most important objectives the creation of IIS's for the oil and gas industry and for environmental protection, based on the employment of IVK's and the latest component base; in particular, the

creation of mobile IVK's for geophysical research and research on turbulent and exploitable wells (it is a good idea to single out a head organization in Minpribor [Ministry of Instrument Making, Automation Equipment and Control Systems]), as well as IIS's for monitoring the state of the environment; the development of IIS structures for different levels of ASU's [automated control systems] for the oil industry and of methods and equipment for metrological hardware for IIS's for the oil industry; the production of special microelectronics equipment designed for the oil industry.

The conference recommended that the editorial boards of the journals IZMERITEL'NAYA TEKHNIKA, PRIBORY I SISTEMY UPRAVLENIYA and IZMERENIYA, KONTROL', AVTOMATIZATSIYA set up "Information and Measuring Systems" columns and publish articles on IIS's in them, including the most important papers from this and subsequent conferences on IIS's.

BIBLIOGRAPHY

1. Kavalero, G.I. "Computing and Measuring Complexes," PRIBORY I SISTEMY UPRAVLENIYA, No 11, 1977.
2. Advanced list of publications on SM computers, PRIBORY I SISTEMY UPRAVLENIYA, No 10, 11, 12, 1977.
3. Klistorin, I.F. and Podzin, A.Ye. "Principles of the Structure of Systems for Testing and Diagnosing Digital Electronic Equipment," PRIBORY I SISTEMY UPRAVLENIYA, No 2, 1978.
4. Journal's "roundtable" (Baku - "IIS-77"), PRIBORY I SISTEMY UPRAVLENIYA, No 3, 1978.

COPYRIGHT: Izdatel'stvo "Mashinostroyeniye", "Pribory i sistemy upravleniya", 1978

8831

CSO: 1870

SCIENTISTS AND SCIENTIFIC ORGANIZATIONS

VITEBSK ELECTRONIC MEASURING EQUIPMENT PLANT CONFERENCE TOPICS DISCUSSED

Moscow PRIBORY I SISTEMY UPRAVLENIYA in Russian No 5, 1978 pp 58-60

[Article by V.A. Ivanova, journal science editor: "Conference of Journal's Readers in Vitebsk"]

[Text] In November 1977 in Vitebsk was held a conference for readers of the journal PRIBORY I SISTEMY UPRAVLENIYA, arranged by the Vitebsk Electronic Measuring Instrument Plant (VEEP), the Scientific Research Institute of Electronic Measuring Instruments (Leningrad), and the editorial board of the journal. Taking part in its proceedings were more than 70 specialists from Moscow, Leningrad, Kiev, Khar'kov, Ul'yanovsk, Kuybyshev, Vil'nyus, Smolensk, Kaliningrad and Vitebsk. Attending the conference were developers and consumers of instruments whose series production takes place at VEEP. As the conference was under way and directly in laboratories, specialists could obtain answers to questions of interest to them.

The opening address to the participants in the conference was delivered by N.A. Mironov, chief engineer at VEEP, who acquainted those attending with the history of Vitebsk, which celebrated its 1000th anniversary in 1974, and with the history of the plant.

The Vitebsk Electronic Measuring Instrument Plant was created in September 1952 at the center of a home appliances plant. Within a short time new equipment and technological processes were mastered, and as early as August 1953 the first lot of electronic measuring instruments was produced. With each year the plant has expanded, has increased its production capacities, and has mastered new more complicated electronic measuring instruments.

In 1964 at the plant were introduced the Novocherkassk system of efficient production planning and the system of flawless fabrication of products, which have made it possible to improve considerably production figures and the quality of products manufactured. Since January 1967 the plant has operated under the new stipulations for planning and economic incentives.

In 1968-1969 VEEP for the first time in the USSR mastered the production of a series of transistorized equipment--measuring converters of electrical

magnitudes designed for machines for centralized monitoring in automatic control of technological processes in power engineering and industry.

The plant's products have more than once been demonstrated at oblast and republic exhibitions, as well as at the USSR VDNKh [Exhibition of Economic Achievements]. Creators of the best exhibits have been awarded USSR VDNKh medals, and the plant has received first-place and second-place certificates and the USSR VDNKh Certificate of Honor.

The chief engineer of the VEEP SKB [special design bureau], R.I. Agrest, spoke about the key trends in specialization at VEEP. At the present time the plant is specializing in the production of the following electronic measuring equipment products: primary and secondary measuring converters of electrical magnitudes, including amplifiers and miniature-panel indicating electromechanical measuring instruments for heavy-duty operating conditions, and indicating instruments based on new electrophysical effects. Products made by the plant have enjoyed a high demand in our country, are being exported, and are being produced as only better- and top-quality products.

The science editor of the journal, V.A. Ivanova, gave a report on the work of the journal's editorial staff and editorial board, on methods of organization, and on the significance of columns for different trends in instrument making, on the future plans of the editorial staff, and on new forms of cooperation with readers, authors and reviewers.

In holding a discussion of the journal's work, representatives of VEEP, Candidate in Technical Sciences V.I. Bekeshev and engineers S.A. Litvinchuk and A.N. Lyadvin, remarked that the journal's subject matter is topical and that the materials printed in it provide necessary information to developers for solving problems in the structural and schematic design of measuring equipment.

In connection with the rapid rate of development of analog and digital-analog instruments with electro-optical scales, it was suggested that the following be done: that a column for materials on this subject be published; that readers be periodically informed about new developments and the design principles of electro-optical indicators; that information be made available on the new component basis of instrument making and on allied industries, as well as new materials which hold promise for application in the industry. Among their wishes representatives of VEEP also recommended that articles be published more often which throw light on the general prospects and development trends of instrument making in the USSR and abroad, which will make it possible for specialists to become oriented toward future developments in good time.

Engineer A.D. Pospayev, representative of the Kiev Institute of Automation imeni the 25th CPSU Congress, gave a plus rating to the work done by the team of the editorial staff in advertising on the journal's pages the foremost achievements of science and engineering in the area of creating

new instruments and systems and expressed a number of wishes, in particular, that readers be informed about instruments and equipment which make it possible to operate under difficult operating conditions.

Candidates in technical sciences R.S. Yermolov and G.S. Pevzner from VNIIEP [All-Union Scientific Research Institute of Electronic Measuring Instruments] (Leningrad) noted the great significance of the columns set up by the journal, imparted in particular by the participation in them of the head organizations and those working most successfully in a particular direction.

Then papers and reports on the conference's program were heard and discussed. G.S. Pevzner (VNIIEP), candidate in technical sciences, delivered a paper on the development of a standard-unit combination of devices for electronic measuring equipment (ASET) in the 10th Five-Year Plan period.

Second-generation ASET hardware has previously been in the form of equipment complete from the functional and design standpoint and of independent utilization significance and having, consequently, certified technical and operating characteristics (including metrological). But for the purpose of more extensive and more convenient utilization of this hardware in information and measuring systems and in computing and measuring complexes (IVK's) the systems specifications for them have been extended to include the following: the presence of remote control and the ability to switch from self-contained to remote control by an outside signal, as well as to switch from a self-contained to a common system power supply (when the self-contained is cut off); an outlet for an instrument interface by means of a peripheral interface module or an internal interface board (unit); programmability for multi-functional purposes and for alteration in the internal structure; several variants in design to accommodate area of application, etc.

The structure and functional capabilities of ASET hardware which will be developed at the end of the 10th Five-Year Plan period are reflected to a considerable extent by the mastery of the series production of microprocessors.

Extension of the ranges of application of ASET hardware in different branches of industry (e.g., in ferrous and nonferrous metallurgy, the chemicals industry, machine building, etc.), in scientific research, medicine, transportation, etc., has caused a modification of and addition to the structure of the standard-unit combination. With extension of systems applications the requirements for different sorts of compatibility of standard-unit hardware have become specific and been improved. A brief analysis of the technical level of ASET second-generation hardware has shown that their technical characteristics meet the main requirements of the national economy and the level of foreign analogs. Much attention in the work program for ASET in the 10th Five-Year Plan period has been paid to problems relating to development of the design element base and metrological hardware.

The technical and economic indicators for the development of ASET in 1976-1980 testify, in particular, that the output of ASET hardware, as a percentage

of the total amount of electronic measuring equipment hardware, will have increased by 1980 to 46 percent, from 17 percent in 1975.

Engineer R.R. Groundon (TsNIIKA [State Central Scientific Research Institute of Complex Automation], Moscow) reported on modern trends in the design and instrumentation of ASU TP's [automated systems for controlling technological processes] in power engineering. The development of power engineering at the current stage is characterized by the extensive introduction at heat and power plants of large power plants with a capacity of 300, 500 and 800 MW. In addition, large-scale construction is under way on nuclear power plants and large hydroelectric power plants. There has been a drastic rise in the requirements for systems for controlling the power equipment of power plants for purposes of enabling maneuverability, frequent starts and stops, rapid variations in load, and reliability and practicability of control.

To control the country's large-capacity power business, the first phases of ASU TP's have been created, which employ computer hardware at all levels of production, relaying and distribution of electrical power. Power is a major customer of the instrument making industry.

The key hardware for creating ASU TP's in power engineering consists of various types of combinations of GSP [State System of Industrial Instruments and Automation Equipment] hardware, such as ASVT [standard-unit system of computer hardware], ASTT [standard-unit system of technological equipment], AKESR [expansion unknown], ASET [standard-unit system of electronic measuring equipment], ASKR-ETs [expansion unknown], etc., series produced by plants of Minpribor. [Ministry of Instrument Making, Automation Equipment and Control Systems].

To ensure high reliability and commercial efficiency in the production of electric power, there are high requirements for instrument making industry hardware, such as high reliability ratings, noise immunity of signals, unification of input and output signals, high metrological characteristics, structural soundness for operating conditions at power plants, etc.

For purposes of raising the effectiveness of using computer hardware in ASU TP's, it is necessary to enlarge and expand the nomenclature for the production of new instruments, in particular, sensors with enhanced precision, needed for estimating technical and economic indicators, sensors for chemical testing, equipment for displaying summarized information on CRT displays, etc.

Analysis of trends in the development of modern instrument making industry hardware for ASU TP's makes it possible to make the following conclusions about its most characteristic features. It has the following requirements: systems capability, general-purpose capability, unification of peripheral links, microminiaturization, standard-unit design, use of built-in microprocessors, performance of several functions, high-level integration of electrical circuitry, and employment of fourth-generation components.

The speaker also enumerated trends in the development of ASU TP's in power engineering, such as improvement of existing ASU TP's and development of new types; development of the "Energiya" integrated industrial automated control system (OASU), with respect to the entire production complex (power plant units, power plants, rayon power administrations, united power systems, the USSR Unified United Power System); creation of different types of hierarchical information networks in the OASU, with the employment at different hierarchical levels of computer hardware (microprocessors, minicomputers, and medium-capacity computers); development of operating materials for ASU TP's; development of ASU TP software to solve problems in monitoring and control; modernization of the fabrication of hardware for ASU TP's, as well as expansion of the nomenclature and heightened production of instruments for power engineering needs; creation of systems of standard solutions for introducing promising ASU TP's in power engineering through industrial methods.

Candidate in Technical Sciences R.S. Yermolov gave a report on series of IVK's based on new ASET equipment. The creation of IVK's has become a reality because of successes achieved in recent years in the field of computer technology and because of the capabilities of electronic measuring equipment. Experimental design work in this area has advanced along two lines: creation and mastery in series production of IVK's based 1) on series produced ASET hardware, and 2) on ASET-II (second generation) hardware, which will experience industrial mastery in the immediate future. With regard to line 1, customers can obtain two types of IVK's which will make it possible to raise labor productivity considerably when performing both scientific experiments and different kinds of industrial tests. A complex designed for studying rapidly changing processes includes three F799/2 measuring commutators, an F4221 rapid-response meter, an F4810 digital-analog converter, F7073/4 and F7073/7 measuring amplifiers, and an N709 plotter. The presence in the makeup of this IVK of an SM-3 type minicomputer makes it possible flexibly to transform its structure via software to suit the customer's objective.

An information and measuring complex for industrial tests, containing an F799/1 measuring commutator, an Sh11516 integrating voltmeter, an F7046 voltage calibrator, an N710 roll-type plotter, and an SM-3 minicomputer, makes it possible to perform experiments requiring above all the highest precision in determination. With regard to line 2, the proposal is to suggest to the customer that IVK series which is capable of solving numerous problems of many kinds, both in the area of industrial testing, and in scientific research, including in solving problems of communicating with the subject of study.

A.N. Lyadvin (VEEP) reported on the state and prospects of advances in measuring converters for electrical magnitudes and in measuring amplifiers, and Engineer S.A. Litvinchuk spoke about the prospects of advances in digital-analog instruments with electro-optical scales for difficult conditions of operation.*

*Cf. articles by S.A. Litvinchuk et al. and A.N. Lyadvin et al. in this issue of the journal.

Engineer V.V. Lappo delivered a paper not on the conference's program, "Trends in the Development of Industrial Measuring Converters." Measuring converters (IP's) of precision class 0.5 to 1.5 are required for temperature gauges in the operation and testing of heat and power plants, transportation equipment, and chemical, metallurgical, and other units. IP's put out by VEEP (e.g., the F7025) have a precision class of 0.05, which considerably complicates the system and increases the labor intensiveness of adjusting.

For industrial consumption it is obviously a good idea to produce less accurate but simpler miniature IP's based on modern components. Another way to expand production of IP's is to produce group IP's with 30 to 50 measuring channels in a single instrument with a single amplifier and commutator.

Candidate in Technical Sciences M.B. Leytman (Smolensk Branch of MEI [Moscow Institute of Power Engineering]) reported on the application of the principle of invariance to improve the metrological and dynamic characteristics of measuring and functional converters. To improve the precision of measuring and functional converters (IFP's), negative feedback (OOS) is employed, but then, as a rule, the dynamic characteristics of IFP's worsen. Application of the principle of invariance by insignificant complication of the circuitry of IFP's makes it possible substantially to improve their dynamic characteristics and, in particular, drastically to improve their response with a simultaneous increase in precision.

Invariant IFP's can be made by adding an extra channel to the IFP. State-of-the-art components make it possible in many instances to get but a slight multiplicative error in the extra channel, and the additive error does not exert an influence on the converter's rapid response. Application of the principle of invariance has made it possible to improve the dynamic and metrological properties of the following IFP's: d.c. voltage converters (measuring amplifiers), mean a.c. voltage converters, timing pulse voltage converters, voltage-to-frequency converters, multiplying and dividing timing pulse and frequency pulse counting and resolving equipment, etc.

Improvement of metrological characteristics and reduction of the overall size of IFP's can be achieved by improvement of electrochemical decoupling. Candidate in Technical Sciences F.A. Zykin (Ul'yanovsk Polytechnical Institute) delivered a paper titled "Rates of Flows of Energy from Sources and from the Load in Power Systems, and Their Measurement." With the existence in power systems of loads which impair any indicator of the quality of electrical energy (shape of the current and voltage curve, voltage fluctuations, symmetry of the three-phase system), in addition to the main flow of energy from sources flows of distortion are created, which are generated by abnormal loads. If in the structure of the power system there are loads of a cyclically variable nature, then these loads demand from the sources energy determined by the mean components of the effective values of current and voltage and create a counterflow of modulation energy, which is spread through the power system. There is a similar pattern of circulation of flows with asymmetric

loads, when the flow from sources is determined by the symmetric components of forward-series current and voltage, and the reverse flow by reverse and zero symmetric components.

Thus, for purposes of proper distribution of the energy developed, it is necessary to take into account the energy and to control the rate of the forward flow, i.e., the rate and energy determined by the mean values of the current and voltage of the first harmonic of the forward series.

The rate or energy of flows of all distortions should be added, and from the results of measuring them in loads it is possible to estimate the degree of influence of the load on deterioration of the quality of the energy, whereby if the rate is negative, then the load is a generator of distortions.

The development and application of instruments for registering energy and for controlling quality have made it possible to introduce an improved scientifically substantiated system of commercial estimates for power.

At the concluding meeting of the conference, Chief Engineer of the VEEP SKB R.I. Agrest pointed out that it is a good idea to take measures of this kind to strengthen work contacts between the journal's editorial staff and its readers and authors.

The editorial board and editorial staff of the journal awarded VEEP the Certificate of Honor for conducting this readers' conference at a high level of organization and technology.

COPYRIGHT: Izdatel'stvo "Mashinostroyeniye", "Pribory i sistemy upravleniya",
1978

8831

CSO: 1870

SCIENTISTS AND SCIENTIFIC ORGANIZATIONS

YAROSLAVL' TECHNOLOGICAL DESIGN AND SCIENTIFIC RESEARCH INSTITUTE CONFERENCE

Moscow PRIBORY I SISTEMY UPRAVLENIYA in Russian No 5, 1978 p 60

[Article by V.V. Risunov, engineer: "Fourth Scientific and Engineering Conference of Young Specialists"]

[Text] In November 1977 at the Yaroslavl' Technological Design and Scientific Research Institute was held the fourth scientific and engineering conference of young specialists on the topic "Microelectronics Technology and Automated Designing Systems," arranged and conducted by the council of young specialists, the Komsomol committee, and the administration of the institute. The objective of the conference was to analyze the work of the institute and to reveal ways of enlisting Komsomol members and youth for solving complicated scientific and engineering problems relating to fulfillment of the 10th Five-Year Plan.

The team at our institute, which is rightfully regarded as a young one, has been confronted in the 10th Five-Year Plan period with urgent problems relating to improvement of microelectronics technology and equipment, to mechanization and automation of microelectronics technological processes, and to application of computers in designing microcircuits.

The youth of all subdivisions of the institute have been taking an active part in fulfillment of the goals set. A testimonial to this is the mature scientific and technical level of the papers presented at the conference.

The conference's proceedings took place in sections. A total of 37 papers were heard.

At the full meeting were read two papers which reflected the main trends of the conference's proceedings. In the opening paper Candidate in Technical Sciences V.I. Varenko threw light on the development prospects for microelectronics technology in the industry. This speaker stated that the successful mastery of basic technological processes will open up the opportunity for overall introduction of electronic equipment based on microelectronics. Candidate in Technical Sciences S.A. Yurevich, in his paper "System for Automated Design of Integrated Microcircuits," reflected the level and prospects of the institute's work in this area.

Sixteen papers were read in the first section, "Semiconductor Technology." All these papers were the result of scientific research and experimental design work done along the modern lines of semiconductor technology, MOS technology, the creation of semiconductor thermoplastic recording equipment, and optoelectronics.

Of great practical interest were the following papers by engineers: "BIS's [large-scale integrated circuits] with an Injection-Type Power Supply" by N.G. Toyakov, "BIS's in Devices with Charge Coupling" by A.V. Andreyeva, "Obtaining Dielectric and Conducting Films by the Method of Low Temperature Pyrolysis" by N.K. Filippov, "Ionic Doping as a Method of Creating Semiconductor Structures" by V.G. Artemichev, and "Methods of Plasma Chemical Removal of a Photoresist" by O.I. Rezanova.

Sixteen papers were heard in the second section, "Thin-Film and Thick-Film Technology." All the work discussed was performed within the framework of carrying out the NIR [scientific research work] and OKR [experimental design work] on the institute's topic schedule. The scientific results of the majority of it are of practical interest and have already been utilized in new developments by the institute. The achievements noted in papers by associates of the thin-film technology division, A.A. Yakubinskaya, A.A. Kiselev, etc., have been used in developing a technology for thin-film BGIS's [large-scale hybrid integrated circuits] and a technology for multi-layer switch structures and precision bimetallic masks.

The engineering solutions reported on by associates of the thick-film technology division, O.V. Andrianova, G.V. Borisova, V.I. Chegodayeva and V.N. Filatov, have been used with success in developing a technology for thick-film BGIS's and multilayer switch structures. A paper by V.A. Galkin, "Output Equipment Based on an On-Line Thermoplastic Recording Array," was the result of work under way at the institute on creating information readout systems.

In the third section, "Automated Design Systems," questions were discussed relating to the layout of GIS [hybrid integrated circuit] components and to obtaining and monitoring punched tape in a system for automated design of photomasks. Papers by K.V. L'vov and Yu.D. Yershov on these topics are of considerable interest to specialists working in the area of automating the testing of digital microcircuits.

Discussions of papers were active. Those presented noted the trends in the development of microelectronics which have taken shape at the institute, such as the application of computer technology facilities, the creation and utilization of new materials, and the application of equipment for special-purpose physical chemical monitoring in technology.

In the course of the sections' proceedings, recommendations were given on the activation and necessity of putting into service a number of developments by young specialists, as well as on further improvement of the level of scientific and engineering developments.

The conference offered suggestions to the directorate of the institute, aimed at wider enlistment of youth in participation in the scientific developments of the institute, and also named the following as the most urgent guidelines for development of the microelectronics base of the PTNII [Technological Design and Scientific Research Institute]: creation of a materials science center for microelectronics, adoption of special-purpose equipment for physical chemical monitoring, and development of methods for automated design of photomasks and GIS's and for automated testing of digital microcircuits.

COPYRIGHT: Izdatel'stvo "Mashinostroyeniye", "Pribory i sistemy upravleniya", 1978

8831

CSO: 1870

PUBLICATIONS

NEW BOOKS, CONTENT SUMMARIZED

Moscow PRIBORY I SISTEMY UPRAVLENIYA in Russian No 5, 1978 pp 64-65

[Journal section: "New Books"]

[Text] "Aktual'nyye voprosy teorii i praktiki upravleniya" [Topical Questions Relating to the Theory and Practice of Control], collection of articles, Ya. Z. Tsytkin, chief editor, USSR Academy of Sciences Institute of Control Problems, Moscow, Nauka, 1977, 247 pages, 2950 copies, 1.70 R.

Methods of solving problems in optimal control of complex systems. Application of statistical methods in the theory of control and utilization of computer technology. Problems relating to automated information and control systems. Application of methods of technical cybernetics in economics and engineering.

For specialists in the field of automatic control.

"Analogaya i analogo-tsifrovaya vychislitel'naya tekhnika" [Analog and Analog-Digital Computer Technology], collection of articles, edited by V.B. Ushakov, No 7, Moscow, Sov. radio, 1977, 232 pages, 6400 copies, 0.77 R.

Articles reflecting various aspects of the design and application of analog-digital and analog computer hardware. Methodology of investigation by means of equipment with concentrated and distributed parameters. Design of software for analog-digital systems and design of special-purpose machines and equipment.

For engineers involved in the development and utilization of computer hardware.

Bekker, P. and Yensen, F. "Proyektirovaniye nadezhnykh elektronnykh skhem" [Designing Reliable Electronic Circuitry], translated from English, edited by I.A. Ushakov, Moscow, Sov. radio, 1977, 256 pages, 17,700 copies, 1.20 R.

Ensuring reliability of electronic circuitry at different design stages, taking into account the initial level of the quality of components and constant changes in their parameters over time. Methods of computing the probability of

failsafe operation of circuitry in relation to steady failures. Practical recommendations on enhancing the reliability of actual electronic circuitry. Modeling with a computer.

For developers of radioelectronic apparatus and specialists in reliability.

Biryukov, B.V., Danilov, M.A. and Kivilis, S.S. "Tochnyye izmereniya raskhoda zhidkostey" [Precise Measurement of Fluid Flow Rates], reference book, Moscow, Mashinostroyeniye, 1977, 144 pages, 18,000 copies, 0.39 R.

Methods, equipment and technological operations for reproducing and measuring fluid flow rates. Technical characteristics of apparatus used.

For scientific personnel and engineers involved in the design and utilization of equipment for monitoring the parameters of fluids in technological units.

Veynberg, V.B. and Sattarov, D.K. "Optika svetovodov" [Light Pipe Optics], second edition, revised and expanded, Leningrad, Mashinostroyeniye, 1977, 319 pages, 6000 copies, 1.49 R.

Fundamental rules for the propagation of rays through transparent light pipes of different designs. Methods of estimating the optical transmission of conical beams by light pipes. Results of experimental research on transparent light pipes. Application of fiber optics in instrument making. Classification of light pipe parts.

For engineering and technical personnel working in the field of optical instrument making.

Zastenker, G.S. "Proyektirovaniye i organizatsiya mashinoy obrabotki uchethno-ekonomicheskoy informatsii" [Planning and Organization of Computer Processing of Economic Reporting Information], Part One, "Fundamentals of Planning and Organization of Computer Processing of Economic Reporting Information," third edition, revised and expanded, reference manual for computerized reporting centers, Moscow, Statistika, 1977, 208 pages, 36,000 copies, 0.83 R.

General questions relating to planning: examination and study of processes for mechanization; planning codes, primary documents and document flow, punching simulators and reporting registers; estimates of economic efficiency; technological documentation; arranging for putting the work project into operation.

Kelekhsayev, A.A. and Belyayev, L.P. "Sistemy integratsii i obrabotki dannykh SIOD1, SIOD2" [SIOD1 and SIOD2 Data Integration and Processing Systems], Moscow, Statistika, 1977, 208 pages, 21,000 copies, 0.86 R.

Principles of organization of information systems of the data bank type. Description of structure and function of software components, structure of data bases created, and methods of setting up information files. Parameters of the generation of systems and recommendations on designing and tailoring them to conditions of a specific application.

For specialists involved with problems of designing and developing automated systems, production organizers and mathematician-programmers,

"Mikroelektronika i poluprovodnikovyye pribory" [Microelectronics and Semiconductor Devices], collection of articles, edited by A.A. Vasenkov and Ya.A. Fedotov, No 2, Moscow, Sov. radio, 1977, 304 pages, 9000 copies, 1.14 R.

Articles by domestic authors on general problems and the physical fundamentals of microelectronics, on semiconductor integrated microcircuits, integrated hybrid and film-type microcircuits, on integrated circuit technology, microcircuitry engineering, methods of testing and measuring equipment, on the design of microelectronic equipment and the technology of its fabrication, on optoelectronics and new trends in microelectronics, and also on new semiconductor devices and features of their application in circuits.

For a wide range of specialists in the field of developing, fabricating and using microcircuitry in microelectronic equipment.

Mitrofanov, V.V. and Odintsov, B.V. "Programmy obsluzhivaniya OS YeS EVM" [Operating Software for Unified System Computer Operating Systems], Moscow, Statistika, 1977, 136 pages, 50,000 copies, 0.45 R.

Structure of operating software and the most typical operations performed by program operating systems for the Unified Computer System. Recommendations on programming operating software.

For programmers, designers and computer center personnel.

"Nadezhnost' elektronnykh elementov i sistem" [Reliability of Electronic Elements and Systems], translated from German, edited by Kh. Shnayder, Moscow, Mir, 1977, 258 pages, 1.28 R.

The state of the art of the theory and practice of the reliability of integrated microcircuits, transistors, resistors, capacitors, magnetomechanical filters, contact connections and systems. Information on the rate and physics of electronic circuit failures. Non-destructive methods of testing, utilizing a scanning electron microscope and infrared visual heat emission equipment. Analysis of noise in semiconductor devices.

For specialists involved in developing and using radioelectronic apparatus and computer hardware and for engineering and technical personnel in other sectors of the national economy interested in questions relating to reliability.

Nikityuk, N.M. "Programmo-upravlyayemyye bloki v standarte KAMAK" [Program Controlled Blocks in the KAMAK Standard], Moscow, Energiya, 1977, 153 pages, 2290 copies, 0.46 R.

Organization and design of digital block systems in the modern KAMAK standard and their operation. Application of these blocks in scientific research and

in industry, where preliminary gathering and processing of information are required for subsequent transmission of it to a computer. Descriptions, characteristics and basic circuitry of devices and equipment for linking with a computer implemented in the KAMAK standard.

For engineers specializing in the field of designing digital equipment, of control, and computer technology, and for computer users.

"Proyektirovaniye mikroelektronnykh tsifrovyykh ustroystv" [Design of Micro-electronic Digital Equipment], edited by S.A. Mayorov, Moscow, Sov. radio, 1977, 271 pages, 27,000 copies, 0.85 R.

Design of electronic apparatus of different generations. Analysis of nomenclature and varieties of digital units. Characteristics, comparison criteria, and development trends for the component basis of microelectronic equipment. Structural and schematic features of digital units of the series and combination type, and methods of designing them to take into account ensurance of functional reliability. Design variants and key design parameters of integrated microcircuits and microassemblies. Variants of installing microcircuits on commutation boards, and methods of forming equipment into a unit to take into account ensurance of noise rejection.

For engineering and technical personnel involved in developing, designing, and using microelectronic automation equipment, including digital computers utilizing integrated circuits.

Pyatin, Yu.M. "Proyektirovaniye elementov izmeritel'nykh priborov" [Design of Measuring Instrument Components], textbook for VUZ's, Moscow, Vysshaya shkola, 1977, 304 pages, 14,000 copies, 1.03 R.

Engineering methods of designing mechanical and electromagnetic components for measuring machinery and instruments, and the selection of the best relationship between their parameters according to the Q criterion. Investigation of the problem of the radical change in the design of permanent magnets made of new magnetic materials. New methods of designing magnets under the influence of an external field.

Rastrigin, L.A. and Madzharov, N.Ye. "Vvedeniye v identifikatsiyu ob'yektov upravleniya" [Introduction to Identification of Controlled Systems], Moscow, Energiya, 1977, 215 pages, 5000 copies, 0.58 R.

Discussion of key ideas relating to the identification of systems of different kinds and purposes, structured in keeping with the "from model to method" principle, i.e., a description of a model setting the parameters of the problem posed prior to discussion of the method of identification.

For engineering and technical personnel involved with problems in automatic control.

Repin, V.G. and Tartakovskiy, G.P. "Statisticheskiy sintez pri apriornoy neopredelennosti i adaptatsii informatsionnykh sistem" [Statistical Synthesis with Apriori Indeterminacy and Adaptation of Information Systems], Moscow, Sov. radio, 1977, 432 pages, 7000 copies, 2.37 R.

Synthesis of a broad class of systems (systems for controlling processes and experiments, economic systems, and many others). Accomplishment of synthesis with unknown operating conditions of the system. General methodology of synthesis. Solution of a wide range of problems relating to different classes of systems, based on application and development of the theory of statistical solutions. Obtaining optimal systems and processes which prove to be adaptive.

For scientific personnel and engineers involved with problems relating to transmission and processing of information, as well as with control of subjects, processes and experiments.

Rozhkov, L.I. "Sredstva peredachi dannykh v ASU" [Data Transmitting Equipment in Automated Control Systems], Kiev, Tekhnika, 1977, 184 pages, 9000 copies, 0.79 R.

Systematization of basic information on all types of data transmission equipment and on telegraph equipment used to exchange information between ASU systems. Operating principles, layout, and development prospects for data transmission equipment and telegraph equipment series produced by industry. Methods of efficient control of data transmission channel equipment and methods of rating their effectiveness and functional reliability.

For engineering and technical personnel involved in developing and using data transmission equipment in ASU's.

Sviridenko, V.A. "Analiz sistem so szhatiyem dannykh" [Analysis of Systems with Data Compacting], Moscow, Svyaz', 1977, 184 pages, 4200 copies, 1.41 R.

Methods of estimating the key characteristics of systems with compaction of continuous and continuous discrete messages, designed to transmit them in digital form through communication channels with limited carrying capacity, or for recording them in a memory of finite capacity. Investigation of the effectiveness of data compaction algorithms. Analysis of the parameters of buffer memories of data compaction subsystems and of the noise rejection of compacted data transmitted through a channel with noise.

For scientific and engineering and technical personnel specializing in the field of designing and investigating data transmission equipment.

"Tekhnologiya tonkikh plenok" [Thin-Film Technology], manual in two volumes, edited by L. Mayssel and R. Gleng, translated from English under the editorship of M.I. Yelinson and G.G. Smolko, Vol 1, Moscow, Sov. radio, 1977, 662 pages, 20,000 copies, 4.02 R.

Exhaustive reference data on different methods of obtaining thin films (high-vacuum technology, the physical mechanism of spraying materials under the influence of ionic bombardment, methods of obtaining films by ionic sputtering, with reference to technological modes, as well as to the parameters of the equipment needed).

For a wide range of engineers and designers of radioelectronic apparatus and specialists in the field of microelectronics, physics and the technology of making thin films.

COPYRIGHT: Izdatel'stvo "Mashinostroyeniye", "Pribory i sistemy upravleniya", 1978

8831

CSO: 1870

PUBLICATIONS

BRIEF ABSTRACTS OF LIBRARY ACCESSIONS AND BOOK REVIEW

Kiev MEKHANIZATSIYA I AVTOMATIZATSIYA UPRAVLENIYA in Russian No 1, Jan-Mar 1978 signed to press 15 Feb 78 pp 76-77

[Abstracts of papers deposited in the Main Republic Scientific and Technical Library].

UDC 658.012.011.56:657

"Machine Processing of Data for Accounting for Basic Resources in Budget Institutions," A. I. Borodina, I. A. Nekhorosheva, and L. A. Popkova. (Editorial board of the collection MEKHANIZATSIYA I AVTOMATIZATSIYA UPRAVLENIYA), Kiev, 1977, 12 pages with illustrations. (Manuscript deposited in GRNTB UkrNIINTI [Main Republic Scientific and Technical Library of the Ukrainian Scientific Research Institute of Scientific and Technological Information] on 23 August 1977, No 807).

Gives the solution to the problem "Accounting for the Availability and Movement of Basic Resources of a VUZ," which goes into the accounting subsystem of the ASU VUZ and is realized on a "Minsk-32" computer by a set of programs developed in the algorithmic language of COBOL and YaSK. Describes the incoming and outgoing information, composition and content of program modules which execute the job. The problem solution can be used in any budget institution.

UDC 621.9:62-52

"Automation of the Calculation for SAU of Cutting Processes," V. V. Glushko, A. V. Verkhovodov, and Yu. P. Butenko. (Editorial board of the collection MEKHANIZATSIYA I AVTOMATIZATSIYA UPRAVLENIYA), Kiev, 1977, 17 pages with illustrations, bibliography of 2 titles. (Manuscript deposited in the GRNTB UkrNIINTI on 23 August 1977, No. 814).

Discusses a process of automation of calculation of a system on the basis of a generalized structural scheme of an adaptive system which takes into consideration different variants of functional diagrams of machine tools, their drives and sensors of the power parameter (forces, moment, current, and outputs), as well as the types of regulating systems (static and astatic, linear and nonlinear, with direct and transient feed back etc). Methods are suggested for digital modeling which provide rapid verification of solutions obtained.

UDC 621.382.28

"Use of a Method of 'Masks' in Making up a Set of Variable Capacitance Diodes Conjugate by Capacitance," V. Z. Lubyanyy, and A. P. Lebedenko. (Editorial board of the collection MEKHANIZATSIYA I AUTOMATIZATSIYA UPRAVLENIYA), Kiev, 1977, 12 pages with illustrations, bibliography of 2 titles. (Manuscript deposited in GRNTB UkrNIINTI, on 30 August 1977, No. 817).

Discusses the features of using pattern recognition methods in making up a set of variablecapacitance diodes conjugate by capacitance. The method can be used in quality control systems. Describes a method of economic coding of the volt-farad characteristic. Selects an optimum algorithm for automatic classification providing simplification of the system of storage and making up a set of instruments.

UDC 621.9:62-52

"A Machine Method for Studying the Functioning of Cutting Rate Control Systems," V. V. Glushko and A. V. Vorkhovodov. (Editorial board of the collection MEKHANIZATSIYA I AUTOMATIZATSIYA UPRAVLENIYA), Kiev, 1977, 9 pages, bibliography with 1 title (Manuscript deposited in GRNTB UkrNIINTI, on 16 November 1977, No. 874).

Discusses algorithms for analysis and synthesis with the aid of an electronic digital computer of systems for automatic regulation of cutting rates. The algorithm takes into consideration all possible variants of functional diagrams of machine tools, their feed drives, sensors for the control parameter, and various systems (static and astatic, linear and nonlinear, single and multiple circuit). Presents methods of digital modeling on the basis of standard equations of units corresponding to specific elements of the SAU of cutting processes. The graphs shown of the transient

processes obtained in modeling on the basis of the suggested algorithm of the basic variants of the systems serve as corroboration of the capability of calculations of various types of systems.

UDC 674:621.332

"ASU of Quality of Production with an Optimizer and Corrector," V. V. Mazhura and E. V. Tseshkovskiy (Editorial board of the collective MEKHANIZATSIYA I AUTOMATIZATSIYA UPRAVLENIYA), Kiev, 1977, 11 pages with illustrations, bibliography of 2 titles (manuscript deposited in the GRNTB UkrNIINTI on 24 October, 1977, No. 854).

Discusses an industrial system for manufacture of a multi-component mixture. An aggregated factor of quality is realized in a system of optimum control of variation of a complete set of process flows. Defines a priority equalizer.

The equalizer has a variable transmission factor to compensate for transport delay according to a given component criterion and to ensure control efficiency. A method for calculating the contour is given.

UDC 002.63:681.3

"Decreasing Total Search Time in Automated IPS [Information Retrieval Systems] with the Sequential Method of Data Organization," G. Ya. Beregovenko, Ye. I. Gershgorin, V. P. Tron' and V. M. Turanskaya (Editorial board of the collection MEKHANIZATSIYA I AUTOMATIZATSIYA UPRAVLENIYA), Kiev, 1977, 7 pages with 2 illustrations (manuscript deposited in the GRNTB UkrNIINTI on 5 November, 1977, No. 864).

Establishes an association between the number of documents and queries read into memory in which the number of empty runs of magnetic tape will be the minimum. Suggests a procedure for selection of the branch of the search algorithm depending on the number of documents and queries. The search procedure has been realized in the interindustrial automated republic system of scientific and technical information (MARS NTI).

NEW BOOKS

[Review by A. N. Zhigarev, doctor of engineering science, and L. K. Golyshev, candidate of engineering science, of the

book "Upravleniye mashinostroitel'nykh predpriyatiyem na baze tipovoy avtomatizirovannoy sistemy" [Control of a Machine Building Enterprise on the Basis of a Standard Automated System], by I. A. Danil'chenko, V. I. Ulybin, V. N. Fedotov and P. N. Skorobogatov, Leningrad, Mashinostroyeniye, 1976, 382 pages with illustrations, 1,200 copies, price 2 rubles 4 kopeks]

The experience in development and introduction of an ASUP, standard for a group of machine building enterprises, is generalized in the book. The system has been realized at a base enterprise--the "Kirovskiy zavod" production association (Leningrad).

The first chapter contains a short description of the structure and general characteristics of the standard ASUP "Aurora."

The main portion of the book contains material on the overall improvement of an enterprise control system on the basis of the development of an ASUP.

The architecture of the ASUP is discussed from a systems point of view, and the organizational-economic concept is especially singled out as one of the most important components of the system which above all ensures the efficiency and quality of both the ASU itself and the object of control.

The questions of organizations of production, labor and the structure of control are discussed in detail.

Of theoretical and practical interest is the chapter which covers the composition and content of the engineering preparation of production which includes the questions of planning and regulation of the industrial process, control of test production, modeling of the composition of the product, and evaluation of its produceability, technological and tool preparation of production.

Technical-economic planning is assuming special topicality under conditions of scientific and technical progress. Validity of plans; technical-economic indicators (production costs, profit, profitability), with which an enterprise must organize fulfillment of these plans; development and realization of measures for the improvement of the indicators are the indispensable conditions for growth in efficiency and intensification of production. The chapter devoted to

these questions covers the structure and content of the subsystem for TEP [technical and economic planning], and the information link with other subsystems, and also contains the forms of input and output documentation.

Production operations planning (OPP), accounting and regulation are directly and most closely associated with technical and economic planning. The completeness and coherence of the presentation of the material devoted to OPP, the scientific validity of adopted solutions, algorithms, initial and output information and technology of control show the depth of development of the question and the practical value.

The questions of control of quality, material and technical supply, machine and power management, marketing of finished products, transportation management, personnel and financial-bookkeeping activity of the enterprise have been considered taking into account the latest achievements and practice. Efficiency and significance of overall automation of control have been confirmed by the practical indicators of the efficiency of the ASUP "Aurora."

COPYRIGHT: UkrNIINTI, 1978

8545

CSO: 1870

PUBLICATIONS

BRIEF ABSTRACTS OF ARTICLES IN 'MEKHAUZATSIIYA I AVTOMATIZATSIIYA UPRAVLENIYA'

Kiev MEKHAUZATSIIYA I AVTOMATIZATSIIYA UPRAVLENIYA in Russian
No, 1 Jan-Mar 1978 signed to press 15 Feb 78 pp 78-80

[Abstracts of articles in this issue]

UDC 65.012.122

[Text] "Structured Software for Development and Use of a
Complex of Mathematical Models," V. F. Kuznetsov and T. V.
Salova, collection MEKHAUZATSIIYA I AVTOMATIZATSIIYA UPRAVLENIYA,
Kiev, UkrNIINTI [Ukrainian Scientific Research Institute of
Scientific and Technical Information], 1978, No 1.

Discusses the questions of organization of the structure of
particular models (modules) combined into a complex of
models for the purpose of efficient development and use of
them. Bibliography of 3 titles.

UDC 681.3:65.011.46

"Determining Intraplant Reserves for Raising the Technical-
Economic Efficiency of Continuous Industrial Processes," V.
I. Grubov, collection MEKHAUZATSIIYA I AVTOMATIZATSIIYA
UPRAVLENIYA, Kiev, UkrNIINTI, 1978, No 1.

The problems associated with disclosing intraplant reserves
for raising the technical-economic efficiency of continuous
industrial processes are formulated, a technique for deter-
mining reserves is presented, and data on disclosed reserves
for a number of continuous industrial processes are cited.

UDC 658.513

"Control of the Performance of a Group of Asynchronous Final
Processes," I. V. Ilovayskiy, collection MEKHAUZATSIIYA I
AVTOMATIZATSIIYA UPRAVLENIYA, Kiev, UkrNIINTI, 1978, No 1.

A method of presenting information to a dispatcher on the course of the performance of several final processes in a form suitable for comparing them to each other is described. The description is made in an example of monitoring the course of final production processes (tasks). Figures 2, bibliography of 2 titles.

UDC 65.012.122

"On the Decomposition of Some Multicriterial Problems of Interger Programming," M. A. Royzen, collection MEKHANIZATSIYA I AVTOMATIZATSIYA UPRAVLENIYA, Kiev, UkrNIINTI, 1978, No 1.

A multicriterial problem of interger programming is discussed. It is shown that if all the elements of the matrix of limitations of the problem are non-negative, then it is possible to produce a decomposition of the problem into a number of problems of interger programming, each of which has a significantly smaller dimension than the original. A practical interpretation of the results obtained is given.

UDC 658.531:681.3.06

"A Combined Method for Standardizing Labor Outlays for Software for an ASUTP," V. A. Monakov and G. B. Melent'yev, collection MEKHANIZATSIYA I AVTOMATIZATSIYA UPRAVLENIYA, Kiev, UkrNIINTI, 1978, No 1.

Describes a method of calculating the norm for labor outlays for software for an ASUTP [automated system for control of industrial processes] based on the principle of minimization of outlays for development of systems and combining the merits of methods of expert evaluations with mathematical statistics on standardization of labor. Tables 1, and bibliography of 3 titles.

UDC 681.3:658.566

"Evaluation of the Effectiveness of Automation of Attaching Suppliers to Customers," B. V. Timon'kin, collection MEKHANIZATSIYA I AVTOMATIZATSIYA UPRAVLENIYA, Kiev, UkrNIINTI, 1978, No 1.

Discusses methodological questions for determining savings from attaching enterprises-suppliers to customers. A complex analysis is made of courses for obtaining savings, and methods for determining savings by individual courses are offered. Tables 1, bibliography of 6 titles.

UDC 338.912.12:63

"A Method of Optimization for Solving Economic Problems with Fractional Functions," Yu. V. Vasilenko, B. F. Grabchenko and V. P. Gulenko, collection MEKHANIZATSIYA I AVTOMATIZATSIYA UPRAVLENIYA, Kiev, UkrNIINTI, 1978, No 1.

Describes a method for finding the optimal solution to a particular problem with fractional functions of the objective. The method of optimization for a linear-fractional target function amounts to directed scanning of competitive variants which makes it possible to quickly find the optimal solution, and is used for solving economic problems in determining under given conditions the maximum possible indicators of efficiency of agricultural production, the optimum values of which are used as standards. Bibliography of three titles.

UDC 658.012.011.56:658.7.01

"Determining a Rational Level of Reserves," V. I. Garbarchuk, Collection MEKHANIZATSIYA I AVTOMATIZATSIYA UPRAVLENIYA, Kiev, UkrNIINTI, 1978, No 1.

A method is presented for determining a rational level of multiproduct supplies for various complex systems of maintenance based on using tables compiled by computer. Tables 2, bibliography of 3 titles.

UDC 658.012.011.56:658.51

"Determining the Impact of an ASUP on the Regularity of Output of Production," A. M. Pilipenko, Collection MEKHANIZATSIYA I AVTOMATIZATSIYA UPRAVLENIYA, Kiev, UkrNIINTI, 1978, No 1.

Discusses a method for determining the regularity of output of production and reduction of nonproductive expenditures under the conditions of an ASUP [automated production control system]. Bibliography of 2 titles.

UDC 65.011.56:622.3

"Analysis of Problems Solved Under Conditions of Functioning of an ASUTP of a Quarry," R. T. Berezanskiy, Collection MEKHANIZATSIYA I AVTOMATIZATSIYA UPRAVLENIYA, Kiev, UkrNIINTI, 1978, No 1.

Problems of an ASUTP of a quarry using the example of a profile of "Morozovskiy" production association of

"Aleksandriyaugol'" are analyzed, and the basic requirements are determined for hardware and software of an ASUTP of a quarry in the first phase of its design. Bibliography of 2 titles.

UDC 681.3:65.012.45

"Determining Volume of Information-Computing Operations on the Basis of Common Characteristics," Yu. G. Mekinyan and Yu. P. Zaychenko, Collection MEKHANIZATSIYA I AVTOMATIZATSIYA UPRAVLENIYA, Kiev, UkrNIINTI, 1978, No 1.

The volume of information-computing operations for all enterprises of an industry transmitted for solution to a multiple user computational center is predicted on the basis of analysis of the volume of input and output information and the time for solution of one standard problem of the basic production control subsystem of base chemical enterprises. Tables 3, bibliography of 3 titles.

UDC 658.012.011.56:681.3

"An Approach to Construction of a Functional Structure of an ASU," L. A. Shoykhet, V. K. Prochukhan, and S. P. Yefremov, Collection MEKHANIZATSIYA I AVTOMATIZATSIYA UPRAVLENIYA, Kiev, UkrNIINTI, 1978, No 1.

Presents a schematic diagram of an algorithm for construction of a structure. A set of production indicators of an enterprise is formed on the basis of directive indicators, and functional modules for each phase of the production process are selected. An algorithm for the selection of the sequence of introduction of functional modules for an ASU is discussed, and an example is given for construction of the functional structure of an integrated ASU of the Yavorovskiy Mineral Chemical Plant. Tables 1, figures 2.

UDC 002.55.003.13

"An Evaluation of the Economic Advisability of the Introduction of Automated Systems of Scientific and Technical Information," I. V. Zheleznov, V. P. Tron', and A. L. Serebryanyy, Collection MEKHANIZATSIYA I AVTOMATIZATSIYA UPRAVLENIYA, Kiev, UkrNIINTI, 1978, No 1.

Presents suggestions for the economic evaluation of automated systems of scientific and technical infor-

mation (AS NTI) according to the criteria of economic advisability of introduction of the system, and a definable way of comparing outlays for development and operation of an AS NTI with outlays for functioning of an information organ using traditional technology. A technique for calculation of the indicated criteria and some results on the experience of its use in developing an AS NTI are given.

UDC 65.012.2.23

"Validation of the Sequence for Development of an ASUTP in Enterprises of the Sub-branch," V. A. Sokirko and Yu. B. Chaykovskiy, Collection MEKHAHIZATSIYA I AVTOMATIZATSIYA UPRAVLENIYA, Kiev, UkrNIINTI, 1978, No 1.

Discusses the basic provisions for a comparative analysis and quantitative evaluation of a set of technical and economic indicators which allow validation of the sequence for development of an ASUTP of corresponding types of production in enterprises of a sub-branch. Tables 1.

UDC 621.317.77

"An Instrument for Automatic Measurement of Time Intervals," A. A. Byalik, V. V. Dzyuba and V. V. Novitskiy, Collection MEKHAHIZATSIYA I AVTOMATIZATSIYA UPRAVLENIYA, Kiev, UkrNIINTI, 1978, No 1.

Describes the circuitry for a measurer of time intervals intended for protracted continuous duty under production conditions. The instrument includes functional units for measurement of time intervals and converting digital code into a standard analog signal, built with integrated microcircuits. Figures 2, bibliography of 5 titles.

UDC 681.325.36

"A Generator of Pseudorandom Sequences of Test Signals," M. S. Bershteyn, L. F. Karachun, A. M. Romankevich and O. D. Rukkas, Collection MEKHAHIZATSIYA I AVTOMATIZATSIYA UPRAVLENIYA, Kiev, UkrNIINTI, 1978, No 1.

Discusses some requirements for generators of test sequences in automated systems for control of digital circuits.

Presents the principle of construction and the functional circuit of the generator which satisfy these requirements. A feature of the generator is the capability of changing at a preset output the probability of emergence of a unique signal. Figures 2, bibliography of 5 titles.

UDC 658.284

"Means of Representation of Information for Control Panels and Consoles," M. V. Sitnikov, Collection MEKHANIZATSIYA I AVTOMATIZATSIYA UPRAVLENIYA, Kiev, UkrNIINTI, 1978, No 1.

Discusses formats of represented information used in an ASUTP by coal enterprises, and light pipe means of representation of information with the use of which mnemonics and tables are efficiently realized. Tables 2, bibliography of 3 titles.

UDC 621.382.072.1:681.536.57

"Digital Power Regulators in Industrial Electrothermal Installations," K. V. Shelekhov and N. A. Obolentsev, Collection MEKHANIZATSIYA I AVTOMATIZATSIYA UPRAVLENIYA, Kiev, UkrNIINTI, 1978, No 1.

Discusses questions of technical realization of digital power regulators for ASUTP. Presents a number of criteria for selection of rational structures of these devices, and compares a number of schemes of functional converters for power control. Tables 1, figures 2, bibliography of 4 titles.

UDC 681.327.8

"A Signal Converter in Optoelectronic Elements," V. P. Vinnitskiy and A. A. Sergeev, Collection MEKHANIZATSIYA I AVTOMATIZATSIYA UPRAVLENIYA, Kiev, UkrNIINTI, 1978, No 1.

Describes the principle of construction and the circuitry of a converter of signals in new optoelectronic elements, designed for matching telegraph channels of communications with the logic microcircuits of the TTL [transistor-transistor logic] "Logika-1" (series 155) and which provides an exchange of data unipolar messages of telegraph current with a speed up to 1200 bits/second at a distance up to 20 kilometers. Figures 3.

UDC 621.398

"An Automated Information Network on the Base of a 'Kaskad-2' Hardware Complex," V. I. Bretl', Collection MEKHANIZATSIYA I AVTOMATIZATSIYA UPRAVLENIYA, Kiev, UkrNIINTI, 1978, No 1.

8

Covers questions of hardware for ASU for chemical and petrochemical production, describes an automated information network for acquisition, transmission and circulation of technological, plan-economic and director information on the base of a "Kaskad-2" hardware complex, developed and in series production at the Severodonetsk branch of the experimental design office of automation. Figures 1, bibliography of 2 titles.

COPYRIGHT: UkrNIINTI, 1978

8545

CSO: 1870

END