

Received

NASA TECHNICAL NOTE

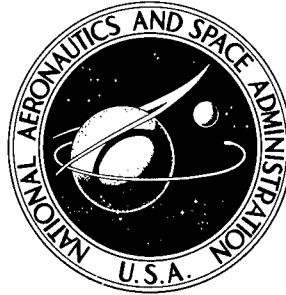

NASA TN D-6483

NASA TN D-6483

**Reproduced From
Best Available Copy**

EVOLUTION OF A SPACECRAFT ANTENNA SYSTEM

by A. Kampinsky

*Goddard Space Flight Center
Greenbelt, Md. 20771*

20000403 116

NATIONAL AERONAUTICS AND SPACE ADMINISTRATION • WASHINGTON, D. C. • SEPTEMBER 1971

DISTRIBUTION STATEMENT A

Approved for Public Release

Distribution Unlimited

1. Report No. NASA TN D - 6483	2. Government Accession No.	3. Recipient's Catalog No.	
4. Title and Subtitle Evolution of a Spacecraft Antenna System		5. Report Date September 1971	
		6. Performing Organization Code	
7. Author(s) A. Kampinsky		8. Performing Organization Report No. G-970	
9. Performing Organization Name and Address Goddard Space Flight Center Greenbelt, Maryland 20771		10. Work Unit No.	
		11. Contract or Grant No.	
		13. Type of Report and Period Covered Technical Note	
12. Sponsoring Agency Name and Address National Aeronautics and Space Administration Washington, D. C. 20546		14. Sponsoring Agency Code	
15. Supplementary Notes			
16. Abstract <p>Following the original spin-stabilized spacecraft (Syncom, Telstar, Relay), the later series—Applications Technology Satellites and Intelsat spacecraft—feature a mechanically rotatable antenna, capable of counter-spinning and pointing a high-gain beam at earth. This feature is an anachronism in the age of electronically collimated and actuated spacecraft antenna systems.</p> <p>The mechanically despun antenna has evolved from a simple, rotatable planar reflector to a more sophisticated multi-frequency, attitude-sensing, high gain antenna for deep space (galactic) probes, tactical communications, and community broadcast applications. The spur of this evolution has been the goal of a two to five year lifetime in space environment with simple mechanical mechanisms, low power consumption, high communications gain, and low noise and magnetic "spillage". The developmental efforts have yielded precise, pulse-driven motors, instrument bearings, lubrication techniques and high reliability electronic circuits.</p> <p>The proofs of the design concepts are the actual flight experiences of the NASA ATS III mechanical antenna system, which, since its November 1967 launch, has performed admirably to date; the Intelsat III system antenna system derived from the predecessor reflective antenna design, and the extension to a military, high capacity despun antenna platform system.</p>			
17. Key Words Suggested by Author Communications spacecraft Mechanically despun antenna		18. Distribution Statement Unclassified-Unlimited	
19. Security Classif. (of this report) Unclassified	20. Security Classif. (of this page) Unclassified	21. No. of Pages 14	22. Price 3.00

* For sale by the National Technical Information Service, Springfield, Virginia 22151

FOREWORD

The policy of NASA is to employ, in all formal publications, the international metric units known collectively as the *Système International d'Unites* and designated SI in all languages. In certain cases, however, utility requires that other systems of units be retained in addition to the SI units.

This document contains data so expressed because the use of the SI equivalents alone would impair communication. The non-SI units, given in parentheses following their computed SI equivalents, are the basis of the measurements and calculations reported in this document.

CONTENTS

Abstract	ii
Foreword	iii
INTRODUCTION	1
REQUIREMENTS OF THE ANTENNA SYSTEM	2
DEVELOPMENT	3
Radio Frequency Performance	3
Electromechanical Aspects	5
Bearing System	6
Lubrication System	6
RELIABILITY ASSESSMENT	7
CONCLUSION	9

EVOLUTION OF A SPACECRAFT ANTENNA SYSTEM

by

A. Kampinsky*

Goddard Space Flight Center

INTRODUCTION

The original communications spacecraft (Courier, Relay, Telstar, and Syncom) represent the particularly simple spin-stabilization technique. Concurrently, these carried simple antennas which radiated in the form of figures of revolution about the spin axis and thus provided low-gain earth coverage. The first of the subsequent Applications Technology Satellites (ATS-1) was equipped with a unidirectional, electronically-collimated antenna radiation envelope, which was counter-rotated against the spacecraft spin; however, electrical dissipative losses and circuit degradations resulted in operational performance 45% below specification levels. Later spacecraft in the spin-stabilized series—ATS III and Intelsat III—feature a mechanically counter-rotating antenna system whose unidirectional, earth-coverage radiation provides the highest effective gain figures for communications. The ATS III has been in continuous operation since November 1967 and has a projected lifetime of five years.

The most significant criterion of reliability - which assures operational status of a spacecraft system - is the inherent simplicity of the mechanically despun antenna, the minimum number of collimation elements, and beam-pointing controls. These parts numbered approximately 5,000 for the all-electronic ATS-I antenna system, and about 1,800 for the ATS III mechanical antenna. Additional features of the mechanical antenna are the multiple-frequency and spaced-frequency operation for uplink and downlink simultaneous receive and transmit capabilities, communications bandwidths of hundreds of megahertz, elimination of electrical rotary joints to minimize noise, and an inherent capacity to automatically point a high-gain radiation beam at the earth or to be steered by ground command. Finally, in the case of failure of electrical or mechanical components, the mechanical antenna system was designed to operate in a fail-safe mode. The antenna system described in this report can revert, on ground command, to the inherent, primary, low-gain omnidirectional antenna system (5 dB) compared with the unidirectional gain of 17.5 dB. The mechanical antenna designs have been applied to space probes, steerable broadcast satellites, and tactical military communications satellites.

*The author holds the basic patent #3,341,151, granted in September 1967, for "Apparatus Providing For A Directive Field Pattern And Attitude Sensing Of A Spin Stabilized Satellite." This concept and patent are the basis of the mechanically despun antennas of the NASA ATS, Comsat ITS, Helios, and the extension to tactical communications spacecraft.

REQUIREMENTS OF THE ANTENNA SYSTEM

The ATS III mechanically despun antenna system (Figure 1) directly replaces the electronic phased array originally designed for ATS spacecraft. Existent phased array control electronics not only synchronizes the mechanical antenna rotation with sunline-spacecraft pulses, but continues

to control spacecraft spin rates and attitude control jets. Telemetry inputs from ground commands are accepted in the spacecraft to direct the radiation envelope on the earth's surface at all times (including eclipse periods), to direct the antenna toward another region of space, and to control the fail-safe operations.

The mechanical and thermal environments represent wide excursions. The vibration spectrum of the launch environment boost phase, of random and peak gravitational forces (8.0 to 15 g's maximum) is supplanted by hard vacuum operations to 1.3×10^{-8} N/m² (10^{-10} torr), ultra-violet and particle bombardments, and thermal differentials of 366K (200°F). The latter temperature excursions, particularly, precluded the use of cement-bonded metal-sandwich construction materials and exposed dielectrics.

The communications electrical specifications require unidirectional radiation patterns for both 6 GHz up-link and 4 GHz downlink frequencies, with bore-sighting within 1.7×10^{-3} radian (0.1 degree) for the 17.5 dB gain envelope (56 times power) and rotationally induced modulation levels within 0.5 dB. No rotary joints or electrical discontinuities were permitted, in order to avoid dispersion, attenuation or noise generation within

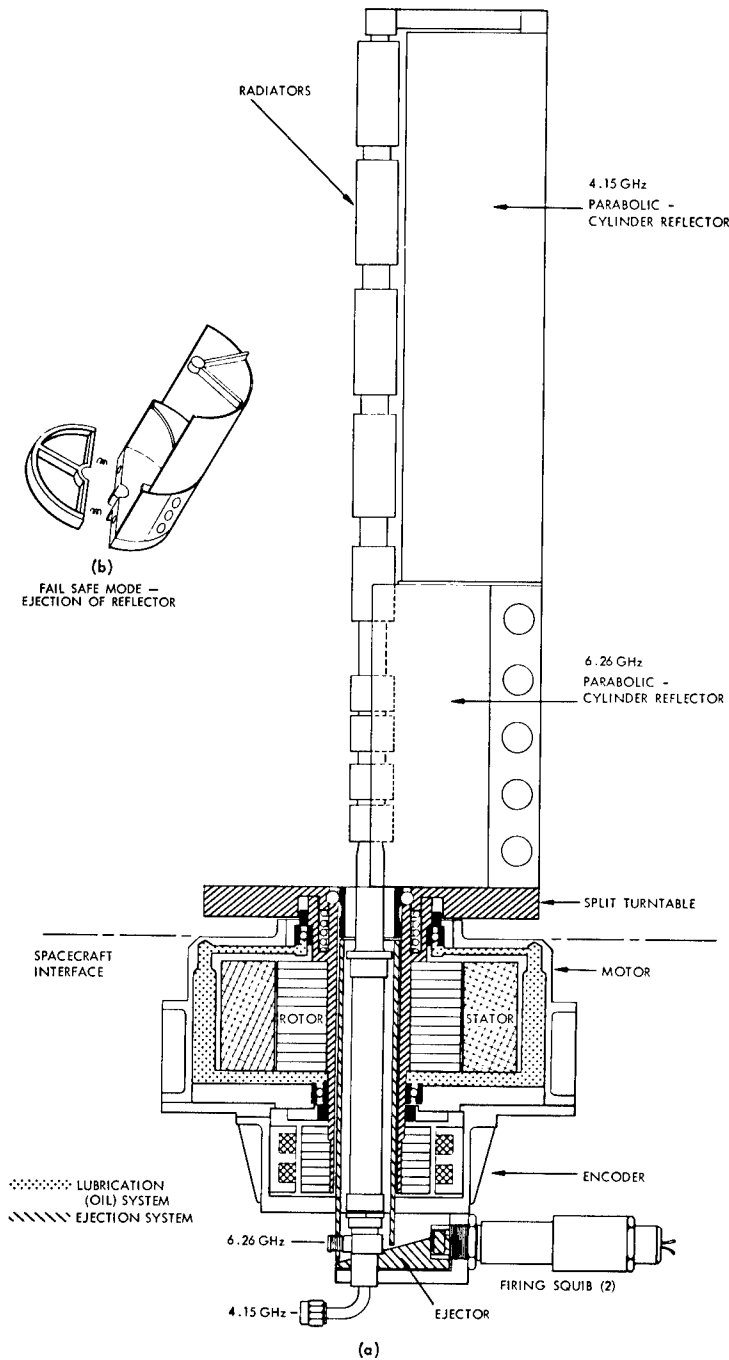

Figure 1. Antenna System for the ATS III.

the 150 MHz communications bandwidths within a 0.5 dB level above inherent system noise.

Mechanical bearings, lubrication, and drive motor systems were required to be qualified on an 8,000-hour life test under space vacuum and temperature conditions. Dual reliability analyses of virtually every component were performed, with a level-of-success goal of 0.97 for one year of operation and 0.95 for five years.

DEVELOPMENT

Radio Frequency Performance

Spin-stabilized communication spacecraft with the spin axis perpendicular to the earth's equatorial plane require the antenna radiation envelope axis to be perpendicular to the spacecraft spin axis, as shown in Figure 2 (a-f). In the earliest antenna designs, a primary horn radiator, with circularly symmetric E and H fields about the horn axis was utilized with inclined planar or parabolic reflectors. This mode was discarded because only circularly polarized radiation was permissible, and radiation patterns were asymmetrical about the principal earth-pointing axis. A collinear primary radiator, rigidly locked to the spacecraft (Figure 1), is coupled with a rotating cylindrical parabolic reflector and requires no radio frequency rotary joints. Linear polarization is inherent and is utilized, during operations, to determine spacecraft attitude as well as to deduce ionospheric electron density values by Faraday rotation measurements at ground stations. If circular polarization were required, a cylindrical polarization grating had also been developed.

The cylindrical parabolic antenna system provides a 0.34-radian (20°) beamwidth in the plane containing the spin axis by disposition of two sets of collinear radiators (length-3 wavelengths) for each frequency, and in the orthogonal plane by the respective aperture dimensions of the two-section parabolic cylinder. The resultant gain figure is 17.5 dB, referred to a linearly polarized radiator. For highest gain figures, antenna reflector sizes can be increased,* and the resultant narrow beamwidths can be directed in the plane perpendicular to the spin axis by positioning of the reflector, and in the orthogonal plane by phase steering of the beam. If the beam is switched above and below the normal to the spin axis (Figure 2b), an error signal can be generated with respect to an incident signal from a ground station directed toward the spacecraft (this concept is part of the basic patent for the mechanically despun antennas). The error signal may be utilized as an indicator of the spacecraft attitude and may be fed to the attitude control system to correct the spacecraft attitude with respect to an earth-line reference. The increasing size of spacecraft would require despinning a section of the spacecraft, and hence a platform is provided upon which large, complete antenna systems are affixed (Figure 2 (g,h)). The military tactical communication spacecraft Tacsat I and a large-capacity Comsat Corporation spacecraft, Intelsat IV, are based upon this concept as extensions of the original designs.

*Helios spacecraft.

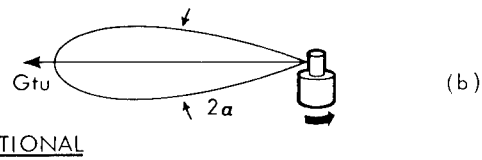
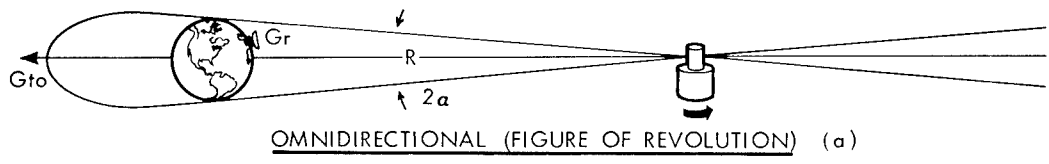

$$P_r = \frac{P_t}{4\pi R^2} G_t \left(\frac{\lambda^2}{4\pi} \right) G_r$$

$$\frac{G_{tu}}{G_{to}} = \frac{2 \sin \alpha}{1 - \cos \alpha}$$

REFLECTIVE DIRECTORS - DESPUN

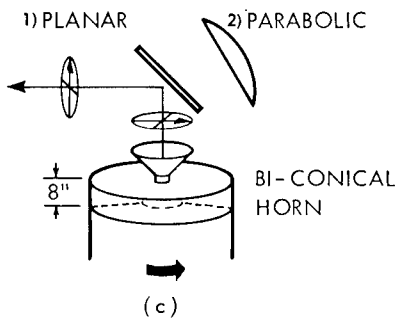

RADIATING APERTURES - DESPUN

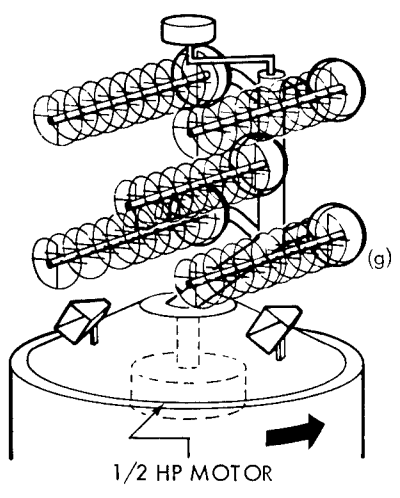
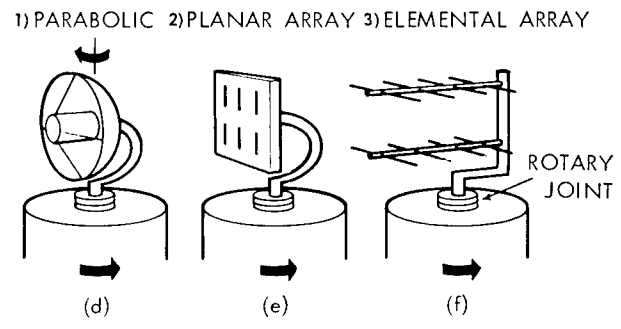

TACSAT I

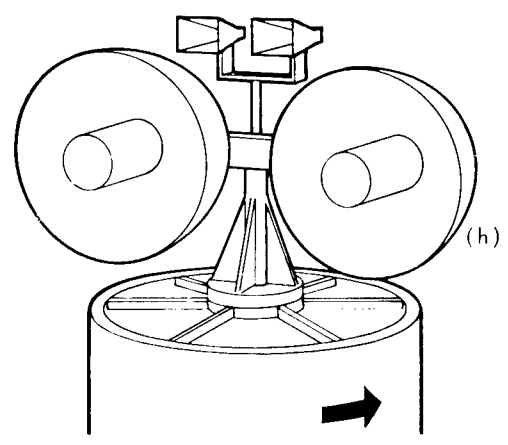

INTELSAT IV

Figure 2. Evolution of Antennas for Spinning Spacecraft.

Electromechanical Aspects

The elements of the radiating dipoles are essentially all metal, with no dielectric materials directly exposed to ultraviolet radiation to avoid degradations. The cylindrical reflector is of electron-beam-welded aluminum construction for low weight, stiffness, and thermal qualities. Although electroformed nickel-honeycomb was considered, all efforts were made to avoid magnetic materials which could, in space probe applications, provide magnetic fluctuations.

Figure 3 represents the electrical system necessary to control the antenna. The antenna drive system consists of a 32-pole (Kearfott Co.) permanent magnet, synchronous, pulse-actuated stepper motor driven by a train of pulses (2^7) which are phase-locked to a train of 2^9 pulses triggered by a sun-line spacecraft sensor. Ground command inputs also provide position control, synchronization, and beam steering via the spacecraft telemetry channels.

The angular position of the motor shaft (and the attached reflector) is known and is controlled within 0.012 ± 0.006 radian (0.7 ± 0.35 degree) from a shaft-mounted encoder. In orbit, the motor is started in rotation by pulse trains of low frequency, and the motor follows the input pulses at

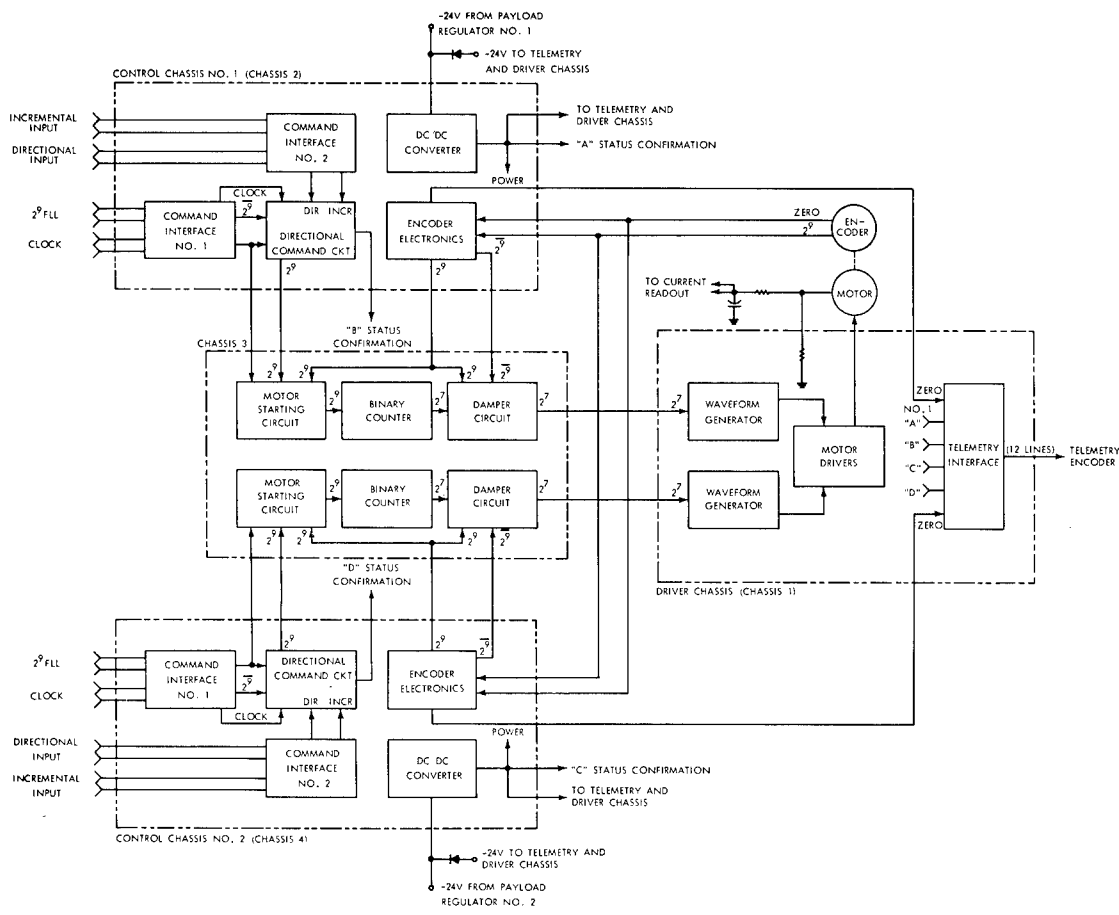

Figure 3. Control System Block Diagram

the rate of one-quarter-tooth displacement per pulse—128 pulses per revolution. At operational spin rates of 100 ± 50 rpm, the motor runs continuously in a slew mode and is locked to the sun pulse through a phase-locked loop and pulse generator as part of the spacecraft jet control system. Power to the motor is supplied by solid-state series/parallel/driven circuits which energize four stator windings in proper sequence. An electrical damper circuit to limit load oscillation is included.

Bearing System

The bearing system consists of two sets of super-precision, instrument-type, angular contact bearings in stainless steel races.* The balls are separated by a cotton-fibre-reinforced phenolic retainer.** Under gravity-free loading, ball skidding was anticipated; hence, a spring-loaded washer was added to provide an axial thrust load of 5.4 kg (12 lbs) which is translated into a radial thrust load to ensue a constant torque and bearing load even under thermal excursions of 55 K (100°F). The increased friction torque was 2.85×10^{-5} meter-kilograms (m-kg) (0.0025 inch-pounds (in-lbs)) out of the total friction torque for the bearing system of 1.87×10^{-4} m-kg (2.28×10^{-4} nominal to 4.56×10^{-4} m-kg maximum) (0.0165 in-lbs (0.020 nominal to 0.040 in-lbs maximum)). The motor torque capability of 2.28×10^{-3} m-kg (0.2 in-lbs) provides a safety factor of 5 for the temperature environment of 244K (-20°F) storage, 266K (20°F) starting temperature, and a maximum of 322K (120°F) for starting and operational levels. With a 5.4 kg (12 lb) preload, the bearing life is computed at 1.93×10^5 hours or 22 years.

Lubrication System

The five-year design goal for successful in-orbit operation was directly related to the choice of the lubrication system for the spatial hard vacuum at 1.3×10^{-8} N/m² (10^{-10} torr) and a total radiation dosage per year of approximately 5×10^2 joules/kg (5×10^6 ergs/gram). Lubrication systems fall into three general categories: (a) Solid film coatings. Solid films would not evaporate; however, their life in hard vacuum is severely limited. Molybdenum Disulfide burnished in inert (Argon) atmosphere, gold, silver and teflon coatings are utilized in terrestrial and spacecraft services. Because the lubricant film cannot be replenished, the limited-wear characteristics and ensuing debris can cause erratic torque behavior. Film penetration failure contributes to premature bearing failure when the cohesive characteristics are exceeded. (b) Solid lubricant in bearing retainer structure. This method provides a replenishing supply of lubricant to the bearing; however, this design is unproven in reliability and life characteristics. (c) Oils and Greases. These have long been satisfactorily used in rolling-contact bearings under normal environmental conditions. Evaporation at low pressure (especially for mineral oils) removes light fractions, leaves a viscous residual, and imposes a variable torque on the bearing system. Oils of a single molecular species give fairly constant rates of evaporation, and residual oils have the same characteristic as the original lubricant. Liquid lubricants have been used in Tiros II and Orbiting Solar Observatory spacecraft for 2 years of operation.

* MPB-3-TAR 25-32 size & type, Miniature Precision Bearing Company, 10 Precision Park, Keene, N. H.

**MIL P 79 FBE phenolic retainer.

An oil system, therefore, was chosen as the most reliable type of lubricator. An annular reservoir, filled with a nylon fiber matrix (25% porosity), stores 25 grams of Apezion-C oil, with a long-chain, polar molecule additive for superior adhesion to races and balls. The oil flows, in parallel, to the upper and lower bearings and exits to space through upper and lower annular (1×10^{-4} -meter) (0.004-inch) molecular seal apertures. The evaporation of the lubricant is derived from kinetic gas theory at equilibrium, in accordance with the equation

$$s = (5.832 \times 10^{-2} P_v \left(\frac{M}{T}\right)^{1/2},$$

where

s = weight of the lubricant evaporated in g/cm^2 -sec,

P_v = vapor pressure of the lubricant at temperature $T(^{\circ}\text{K})$. . . (determined experimentally),

M = molecular weight of the lubricant.

The lubricant loss is computed as $0.0691 \text{ gm}/\text{cm}^2$ -yr. The reservoir volume required for 5 years is $1.565 \text{ cc}/\text{cm}^2$ for an operating temperature range between 266K (20°F) and 322K (120°F) at the motor. Based on measurements, the evaporation rate is extrapolated to $0.1 \text{ gm}/\text{year}$, and the reservoir capacity is 22 cc, (24 grams); hence the expected life based on complete evaporation of all the lubricants is 240 years at 322K (120°F) motor operating temperature.

Two sets of bearings and motors were run in cold-wall vacuum chambers at $1.3 \times 10^{-6} \text{ N}/\text{m}^2$ (10^{-8} torr) for 8,000 hours, and the bearing assemblies were then disassembled and examined for wear. Maximum frictional torque at 266K (20°F) was $5 \times 10^{-4} \text{ m}/\text{kg}$ (0.05 in-lbs); the oil evaporation rate was confirmed at less than 1.0 gram at 322K (120°F) for one year of operation for bearings where races were fully exposed to space, and 0.1 grams per year for the controlled-aperture molecular seal. The bearing wear condition was termed "unused" in the bearing retainer pockets (usually a maximum wear area) which showed no indications of surface wear, and no evidence of pits, surface scratches or cold welds. The test results of 8,000 hours under space-equivalent conditions were deemed sufficiently conclusive to extrapolate to the longer 3- to 5-year operational goal.

RELIABILITY ASSESSMENT

The high reliability assurance levels placed a critical dependence upon the motor-bearing-lubrication system. The most crucial electronic circuitry utilized the series redundant and switched parallel standby for the motor-driving circuits. Figure 4 summarizes the results of the assigned failure rates and system reliability. Two complete electronic subsystems, implying symmetry about a reference line, characterize the control system, from sun reference input to the single drive motor.

Failure rate analysis was made for every integrated circuit over operational temperatures between 244K (-20°F) and 322K (120°F), for an acceleration factor no greater than 64, and a 100% screening basis for all semiconductor components.

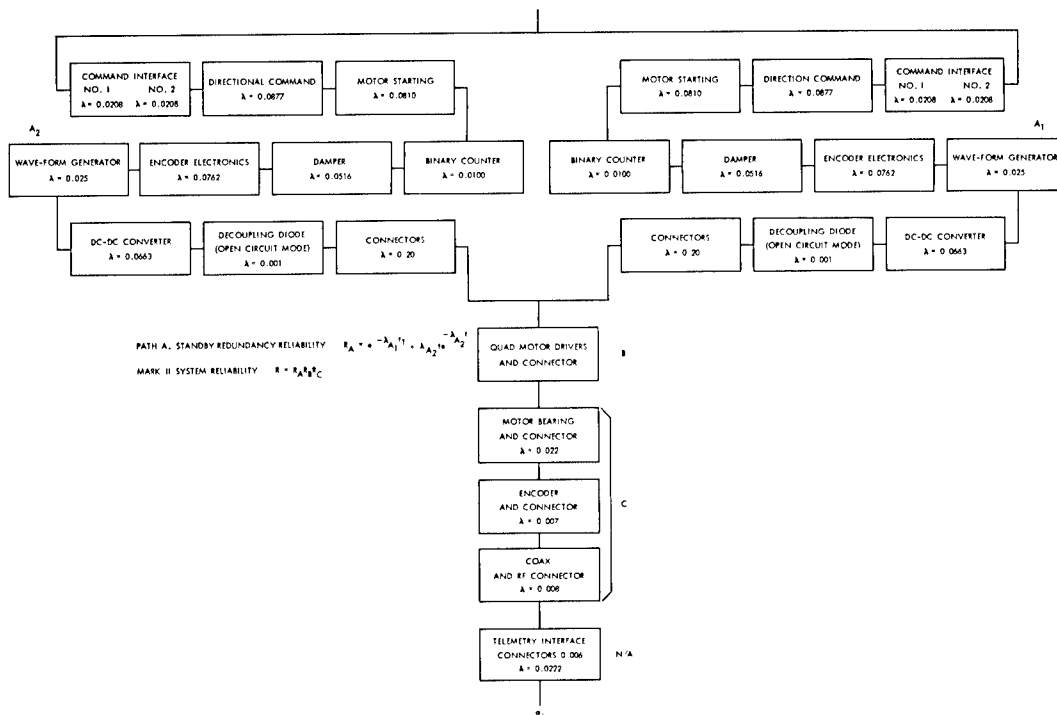

CIRCUIT	FAILURE RATE λ%/1000 HRS.	R(t)		
		1 YR.	3 YR.	5 YR.
COMMAND INTERFACE NO. 1	0.0208			
COMMAND INTERFACE NO. 2	0.0208			
DIRECTIONAL COMMAND	0.0877			
MOTOR STARTING	0.0810			
BINARY COUNTER	0.0100			
DAMPER	0.0516			
ENCODER ELECTRONICS	0.0762			
WAVE-FORM GENERATOR	0.0205			
DC-DC CONVERTER	0.0663			
DECOUPLING DIODE	0.001			
CONNECTORS	0.020			
PATH TOTAL	λ = 0.4604			
PARALLEL STANDBY REDUNDANT	$R_A =$	0.99921	0.99924	0.98200
MOTOR DRIVERS & CONNECTOR		0.99981	0.99933	0.99876
MOTOR, BEARING & CONNECTOR	0.0220			
ENCODER COILS & CONNECTOR	0.0070			
RF COAX & CONNECTOR	0.0090			
NON-REDUNDANT	0.0370	0.99676	0.99017	0.98392
TELEMETRY INTERFACE	0.0162	NA	NA	NA
ESSENTIAL SYSTEM RELIABILITY, B		0.99578	0.98297	0.96521

Figure 4—Reliability Summary.

The quad redundancy represents circuits in series-parallel: series circuits are paralleled by a similar set of circuits, and both sets are arranged as a duplicate, functional group. Each series set is switched by command into operation in place of a failed group. As part of the spacecraft operational performance, critical circuit data are telemetered to the ground for monitoring.

The prices paid for this reliability (series-parallel redundancy protection) are: (1) a fourfold increase in parts and costs, (2) less than a fourfold increase in weight and volume, (3) a reduction in motor driver efficiency (the motor power of 4.6 watts required 1.232 watts in the redundant mode control circuitry against 0.308 watts in the nonredundant control circuit), and (4) increased difficulty of circuit inspection and failure detection.

The motor-bearing-drive system reliability was analyzed by two techniques—the AVCO-RAD* and the RCA-Montreal**—for mechanical and electromechanical parts. AVCO-RAD analysis neglects wearing, assuming that wear life is greatly in excess of a random failure (constant), and is primarily concerned with a random defect in bearings or motor windings. The RCA-Montreal method assumes that wear is the principal consideration, and therefore that the failure rate is a function of time. The former method arrives at a constant failure rate of 0.020%/1,000 hours, for the first year to 0.028%/1,000 hours for the first five years; however, a mean wear life of 10^6 hours (11.4 years) is obtained for the motor-bearing-drive system, and a specific calculation yields a mean wear life of 28 years. The random failure rate therefore is considered as the determinant of success rather than the wear function.

The high probability of success of the mechanical system is nevertheless backed by a fail-safe mode of operation, as seen in Figure 1. When a determination is made that the mechanical system has somehow failed, ground command initiates an order to fire the dual squibs. This action elevates a cylindrical, concentric tube to unlock the split turntable from the rotating shaft. The split turntable, under compressed springs, separates the two major parts away from the collinear radiator stack with a velocity of 1.5 m/sec (5 ft/sec). The antenna system continues to operate as a lower-gain omnidirectional radiator symmetrically disposed about the original spacecraft spin axis.

CONCLUSION

The mechanically despun antenna concept is now demonstrated on an operational quality basis on spacecraft in orbit—ATS III (NASA), Intelsat III A, B, (Comsat Corp.), Tacsat I, and Intelsat IV—and has received major consideration for galactic space probes and broadcast satellite applications. A logical extension of this concept has been to despin a major portion of a spacecraft and to mount antennas as single or multiple apertures to achieve high gain figures (30-40 dB) for communications.

These achievements are possible because bearing, motor and lubrication technologies have been judiciously applied and tested to assure five-year lifetime probabilities greater than 0.965 for the system.

Goddard Space Flight Center
National Aeronautics and Space Administration
Greenbelt, Maryland, December 4, 1969
039-01-01-01-51

* Failure Rates, IDEP 347.40.00.00-B8-01. AVCO Corporation, RAD Division, Wilmington, Massachusetts, April 1962 (now out of print).

**Proposed Procedures for Reliability Assessment of Mechanical and Electromechanical Parts, IDEP 347.25.00.00-F8-01. RCA Victor Co., Ltd., Montreal, Quebec, Canada, January 1963.

NATIONAL AERONAUTICS AND SPACE ADMINISTRATION

WASHINGTON, D. C. 20546

OFFICIAL BUSINESS

PENALTY FOR PRIVATE USE \$300

FIRST CLASS MAIL



POSTAGE AND FEES PAID
NATIONAL AERONAUTICS AND
SPACE ADMINISTRATION

POSTMASTER: If Undeliverable (Section 158
Postal Manual) Do Not Return

"The aeronautical and space activities of the United States shall be conducted so as to contribute . . . to the expansion of human knowledge of phenomena in the atmosphere and space. The Administration shall provide for the widest practicable and appropriate dissemination of information concerning its activities and the results thereof."

— NATIONAL AERONAUTICS AND SPACE ACT OF 1958

NASA SCIENTIFIC AND TECHNICAL PUBLICATIONS

TECHNICAL REPORTS: Scientific and technical information considered important, complete, and a lasting contribution to existing knowledge.

TECHNICAL NOTES: Information less broad in scope but nevertheless of importance as a contribution to existing knowledge.

TECHNICAL MEMORANDUMS: Information receiving limited distribution because of preliminary data, security classification, or other reasons.

CONTRACTOR REPORTS: Scientific and technical information generated under a NASA contract or grant and considered an important contribution to existing knowledge.

TECHNICAL TRANSLATIONS: Information published in a foreign language considered to merit NASA distribution in English.

SPECIAL PUBLICATIONS: Information derived from or of value to NASA activities. Publications include conference proceedings, monographs, data compilations, handbooks, sourcebooks, and special bibliographies.

TECHNOLOGY UTILIZATION PUBLICATIONS: Information on technology used by NASA that may be of particular interest in commercial and other non-aerospace applications. Publications include Tech Briefs, Technology Utilization Reports and Technology Surveys.

Details on the availability of these publications may be obtained from:

SCIENTIFIC AND TECHNICAL INFORMATION OFFICE

NATIONAL AERONAUTICS AND SPACE ADMINISTRATION

Washington, D.C. 20546