

**DISTRIBUTION STATEMENT A**  
Approved for Public Release  
Distribution Unlimited

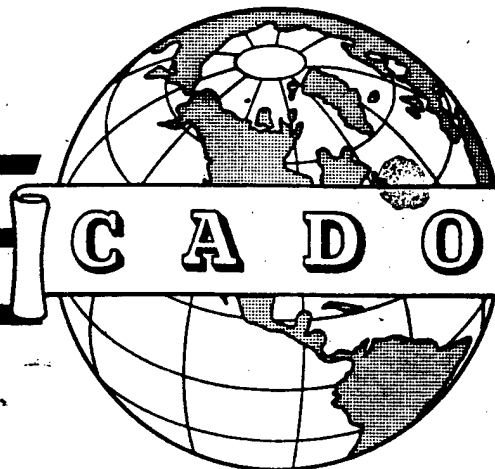

**CENTRAL AIR DOCUMENTS OFFICE**  
**NAVY — AIR FORCE**

#### **NOTE**

When drawings, specifications, and other data prepared by the War Department are furnished to manufacturers and others for use in the manufacture or purchase of supplies, or for any other purpose, the Government assumes no responsibility nor obligation whatever; and the furnishing of said data by the War Department is not to be regarded by implication or otherwise, or in any manner licensing the holder, or conveying any rights or permission to manufacture, use, or sell any patented inventions that may in any way be related thereto.

---

The information furnished herewith is made available for study upon the understanding that the Government's proprietary interests in and relating thereto shall not be impaired. It is desired that the Patent & Royalties Section, Office of the Judge Advocate, Air Materiel Command, Wright Field, Dayton, Ohio, be promptly notified of any apparent conflict between the Government's proprietary interests and those of others.

---

#### **Espionage Act**

**Notice:** This document contains information affecting the national defense of the United States within the meaning the Espionage Act (U. S. C. 50:31, 32). The transmission of this document or the revelation of its contents in any manner to an unauthorized person is prohibited by law. (AR 380-5, paragraph 17 b.)

"The above Espionage Notice can be disregarded unless this document is plainly marked with a security classification as "Restricted," "Confidential," "Secret," or "Top Secret."

---

The U. S. Government is absolved from any litigation which may ensue from the contractor's infringing on the foreign patent rights which may be involved.

REPORT DOCUMENTATION PAGE			Form Approved OMB No. 0704-0188	
<small>Public reporting burden for this collection of information is estimated to average 1 hour per response, including the time for reviewing instructions, searching existing data sources, gathering and maintaining the data needed, and completing and reviewing the collection of information. Send comments regarding this burden estimate or any other aspect of this collection of information, including suggestions for reducing this burden, to Washington Headquarters Services, Directorate for Information Operations and Reports, 1215 Jefferson Davis Highway, Suite 1204, Arlington, VA 22202-4302, and to the Office of Management and Budget, Paperwork Reduction Project (0704-0188), Washington, DC 20503.</small>				
1. AGENCY USE ONLY (Leave blank)	2. REPORT DATE DECEMBER 1940	3. REPORT TYPE AND DATES COVERED FINAL JANUARY - OCTOBER 1940		
4. TITLE AND SUBTITLE WIND-TUNNEL CORRECTIONS AT HIGH SUBSONIC VELOCITIES, WITH SPECIAL REFERENCE TO CLOSED CIRCULAR TUNNELS			5. FUNDING NUMBERS	
6. AUTHOR(S) B. GOETHERT				
7. PERFORMING ORGANIZATION NAME(S) AND ADDRESS(ES) CENTRAL AIR DOCUMENTS OFFICE WRIGHT-PATTERSON AFB, OH 45433			8. PERFORMING ORGANIZATION REPORT NUMBER	
9. SPONSORING/MONITORING AGENCY NAME(S) AND ADDRESS(ES) CENTRAL AIR DOCUMENTS OFFICE WRIGHT-PATTERSON AFB, OH 45433			10. SPONSORING/MONITORING AGENCY REPORT NUMBER  ZWB-FB-1216	
11. SUPPLEMENTARY NOTES ATI 33972				
12a. DISTRIBUTION AVAILABILITY STATEMENT APPROVED FOR PUBLIC RELEASE; DISTRIBUTION UNLIMITED			12b. DISTRIBUTION CODE	
13. ABSTRACT (Maximum 200 words)  <p>After a survey of technical reports on wind-tunnel corrections published to date, the author presents a method of approximation for the determination of corrections due to model blockage, wake blockage behind drag bodies, and lift. In accordance with the Prandtl rule, models and wind tunnels in compressible flow are correlated with other models and wind tunnels in incompressible flow. There are definite relations between the corrections for the two correlated tunnels. By applying the Prandtl rule only to flow at a relatively large distance from the models, the wind-tunnel corrections can still be calculated even if the prerequisites of the Prandtl rule are no longer complied with in the vicinity of the models. Particularly extensive tests were made to determine conditions for fuselages and wings of various spans in closed circular tunnels. As a conclusion of the report, the author presents a comparison between calculations and measurements conducted in the DVL high-speed wind tunnel.</p>				
14. SUBJECT TERMS WIND TUNNELS, PRANDTL RULE			15. NUMBER OF PAGES 43	
			16. PRICE CODE	
17. SECURITY CLASSIFICATION OF REPORT	18. SECURITY CLASSIFICATION OF THIS PAGE	19. SECURITY CLASSIFICATION OF ABSTRACT	20. LIMITATION OF ABSTRACT	

# WIND-TUNNEL CORRECTIONS AT HIGH SUBSONIC VELOCITIES, WITH SPECIAL REFERENCE TO CLOSED CIRCULAR TUNNELS

by B. Goethert

## Abstract:

After a survey of technical reports on wind-tunnel corrections published to date, the author presents a method of approximation for the determination of corrections due to model blockage, wake blockage behind drag bodies, and lift. In accordance with the Prandtl rule, models and wind tunnels in compressible flow are correlated with other models and wind tunnels in incompressible flow. There are definite relations between the corrections for the two correlated tunnels. By applying the Prandtl rule only to flow at a relatively large distance from the models, the wind-tunnel corrections can still be calculated even if the prerequisites of the Prandtl rule are no longer complied with in the vicinity of the models. Particularly extensive tests were made to determine conditions for fuselages and wings of various spans in closed circular tunnels. As a conclusion of the report, the author presents a comparison between calculations and measurements conducted in the DVL high-speed wind tunnel.

## Index:

- I. Problem and Technical Reports Published to Date
  - A. Approximate Calculation by Lamla
  - B. Approximation by Franke and Weinig
  - C. Purpose of Present Research
  
- II. Correction of Undisturbed Flow Due to Model Blockage in Incompressible Flow
  - A. Equivalent Doublet Strength or Source Strength of a Model
    1. Equivalent Doublet Strength of a Model without Wake
    2. Equivalent Source Strength for Consideration of Wake Blockage Behind a Drag Body
  
  - B. Disturbance Velocity at Center Line and at the Wall Due to Model and Wake Blockage
    1. Disturbance Velocity Due to Model Blockage
    2. Blockage Correction for Models of Very Great Length
    3. Disturbance Velocity Due to Wake

- III. Correction of Oncoming Flow Velocity Due to Model Blockage and to Wake at High Subsonic Velocities within the Range of Validity of the Prandtl Rule
  - A. Model Blockage
  - B. Incremental Velocity Due to Wake
- IV. Correction of Oncoming Flow Velocity Due to Model Blockage and to Wake After the Prandtl Rule No Longer Applies in the Vicinity of the Model
- V. Tunnel Corrections Due to Lift at High Subsonic Velocities
  - A. Wing in Free Air Stream
  - B. Wing with Lift in Wind Tunnel
- VI. Application of the Above-mentioned Wind-tunnel Corrections
  - A. Possibility of Superposition of Individual Corrections
  - B. Application of Corrections to Wind-tunnel Tests
  - C. Exemplifying Calculations and Comparison with the Approximations by Lamla and Ferri
  - D. Application of the Adiabatic Equation to Wind-tunnel Corrections
- VII. Comparison of Calculated Corrections with Wind-tunnel Tests
  - A. Variation of Wall Pressure Due to Suspension of Rectangular Wings of Varying Chord Length
  - B. Effect of Lift on Wall Pressures
  - C. Pressure Drop in Test Section Due to Wake Blockage
- VIII. Summary

## I. PROBLEM AND TECHNICAL REPORTS PUBLISHED TO DATE

If a model of finite thickness is placed into a closed tunnel, the cross section of the tunnel in which the model is suspended will be constricted to a certain extent as a consequence of model blockage. The air stream thus is forced to flow past the model at a higher velocity than that of flow of an unrestricted air stream. On applying the measured results to the free air stream, it should be considered, therefore, that the measured values must be correlated to a higher velocity than that prevailing in a tunnel without a model.

In low-speed wind tunnels, which chiefly have been used up to the present time, the increase of velocity due to blockage of the customary small models is so insignificant that it can be disregarded in most cases. At higher flow velocities, however, the velocity correction increases very rapidly and in proportion to the rate at which the velocity of the air stream approaches the speed of sound. This basic characteristic is demonstrated by Ferri (bibl. 1) in his calculation of velocity increase due to a definite constriction of the tunnel, assuming uniform distribution of velocity at the constricted cross section (fig. 1).

From this it appears that if a model causes a 1% constriction of the tunnel, the velocity increase at low Mach numbers is also 1%. At  $M = 0.8$  the velocity increase amounts to 2.7% and at  $M = 0.9$  the increase is as great as 11.0%.

This simple, rough calculation shows the necessity of calculations for corrections of flow velocity due to model blockage at high speeds. It shows also that model dimensions relative to tunnel dimensions have to be held the smaller, the nearer the velocity of flow approaches the speed of sound.

Exact calculations of flow in compressible fluids do not appear to be very promising at the present time on account of the involved formulation when considering that the elementary case of two-dimensional flow past a wing in an unlimited compressible air stream already constitutes the limit of present-day possibilities of calculus. It is thus a matter of finding an approximation representing the actual circumstances as nearly as possible.

### A. Approximate Calculation by Lamla (bibl.2)

A simple estimate of correction for two-dimensional flow was given by Lamla, whose calculations considered the compressibility of flowing air up to factors of higher order. His estimate was based on the following concept:

If a wing of unlimited span (without lift) is exposed to a flow, the distance between two streamlines, running symmetrically to the wing, amounts to  $h_{\infty}$  far ahead and far behind the wing, whereas in the plane of the wing the space between them is forced to the greater distance of  $h_{\infty} + \Delta h$ . At the cross section in which the model is suspended, the flow between two streamlines at a distance of  $h_{\infty}$  from each other no longer conveys the same volume of air  $G_{\infty}$  as that conveyed by the streamlines at the same distance from each other far ahead and far behind the wing. It conveys only the smaller

volume of air  $G_{\infty} - \Delta G$ .

Lamla reasons that the velocity of the air stream  $v$  could be increased in the free air stream by the factor  $\Delta v_{\infty}$  to the extent that the volume of air, conveyed between two streamlines at a distance  $h_{\infty}$  from each other, also amounts to  $G_{\infty}$  at the cross section in which the model is suspended. He considers the increase of velocity required for this purpose as an approximate value for the velocity correction required for closed tunnels, taking the distance between the two streamlines  $h_{\infty}$  to be equal to the distance between tunnel walls.

An important result of Lamla's estimate was the fact that velocity corrections given by Ferri proved to be the upper limiting values, which could be achieved only with very slender models of considerable length relative to tunnel diameter. In most cases, however, the length of the utilized models relative to tunnel diameter is so small and their relative thickness still so large that the disturbance velocity will already have faded considerably passing from the immediate vicinity of the model to the tunnel wall; therefore, the wall effect on flow will be decreased considerably. Velocity correction at  $M = 0.75$  for a 4% constriction of the cross section by the model is given by Lamla (FB 1007/fig 8) as follows:

Model	Thickness ratio $t/c$	Velocity correction $\Delta v/v_{\infty}$
Flat plate in flow direction and of finite thickness	$\rightarrow 0$	11.4% } as per Ferri as per Lamla
Elliptical cylinder	0.1	11.4% as per Ferri 4.2% as per Lamla

The figures found by Lamla can be used as directions for the approximate magnitude of corrections since he used a very simplified method of calculation. Conditions at the tunnel walls are not included completely in his calculation as he figures only with flow being the same at the cross section in which the model is suspended and at the cross sections far ahead and far behind the model. This inexact calculation, for instance, leads to the result that corrections of flow velocity were at all Mach numbers, also at  $M = 0$ , the same for closed and for open tunnels but with an opposite sign. For compressible flow, however, it is known that an open tunnel requires only  $1/2$  to  $1/4$  of the amount of correction required for a closed tunnel (bibl. 3).

#### B. Approximation by Franke and Weinig (bibl.4)

A further approximation for the problem of two-dimensional flow was given by Franke and Weinig. Their investigation figured strictly with conditions prevailing at the tunnel wall and considered the compressibility in a way similar to that expressed in the Prandtl rule. Correction of flow velocity due to model blockage is expressed by them in the following form:



Tests were conducted in a general way for bodies of revolution as well as for wings of various dimensions. Figures published in this report, however, refer primarily to the case of rotationally symmetrical flow. Supplementary figures will be given in a report to be published in the near future.

## II. CORRECTION OF UNDISTURBED FLOW DUE TO MODEL BLOCKAGE IN INCOMPRESSIBLE FLOW

### A. Equivalent Doublet Strength of Source Strength of a Model

#### 1. Equivalent Doublet Strength of a Model without Wake

It is known that flow around profiles and around bodies of any shape can be reproduced by a definite arrangement of sources and sinks or of doublets, selecting their strength and distribution in such a way that the resulting line of separation between the two streamline patterns coincides with the outline of the test body. For great distances from the doublet system or from the system of sources and sinks respectively, it can be demonstrated that disturbance velocities caused by them are equal to those of a single equivalent doublet at the center of gravity of the prevailing system of singularities, the strength of which is defined as follows:

Strength of the equivalent doublet  $M^+ = 2 \sum (aQ) = \sum M$   
where  $Q$  = yield of source or sink respectively

$2a$  = distance between source and corresponding sink

$M$  = momentum of elementary doublet

(The above-mentioned equation is not only valid for bisymmetrical bodies but for bodies of any other shape as well.)

Assuming model dimensions to be small relative to the tunnel diameter, the disturbance velocity of a model at the tunnel wall can be represented by the effect of the above-mentioned equivalent doublet  $M^+$ . For large models, on the other hand, the lengths of which are comparable to the tunnel diameter, the above-mentioned simple estimate of equivalent doublet strength is no longer sufficient. For this case we shall show later on a calculation which permits an estimate of deviation from the single equivalent doublet.

Glauert calculated the strength of the equivalent doublet for bodies of various shapes as a function of maximum thickness and the ratio of thickness to length of the body. (ARC-report in memo. 1566.)

In this report, however, we want to demonstrate a conversion of Glauert's data by representing the strength of the equivalent doublet principally in

relationship to the volume of the blocking body. For slender bodies, the effect of thickness ratio and the difference between two-dimensional and three-dimensional flow are very small in this case.

Strength of the equivalent doublet is in this case expressed as follows:

$$M^+ = 2 \sum (aQ) = \lambda_V V v_\infty^* )$$

where  $V$  = volume of the blocking body and

$v_\infty$  = velocity of the undisturbed oncoming flow

In rotationally symmetrical bodies, the equivalent doublet must be placed at the center of gravity of the body. In cylinders ( $c/b \rightarrow 0$ ), the equivalent doublet strength, as calculated in the preceding formula, must be distributed along the center line of gravity of the cylinder, attaining a uniform distribution of the doublet along the center line of gravity,  $dM^+ = db M^+/b$ .

The factor  $\lambda_V$  depends on the shape of the body and on the thickness ratio. For very slender bodies ( $t/c \rightarrow 0$ ), the factor  $\lambda_V$  is equal to one in the case of rotationally symmetrical flow as well as in the case of two-dimensional flow.

For bodies of elliptical outline, the factor  $\lambda_V$  is demonstrated in fig. 2 as a function of the thickness ratio, i.e., for the two boundary cases "rotationally symmetrical body" and elliptical cylinder ( $c/b \rightarrow 0$ ). The illustration proves that  $\lambda_V$ -values are very close to one in the case of slender shapes such as those used in airplane construction. For example:

Wing with	$t/c = 0.15$	$\lambda_V = 1.15$
Fuselage with	$t/c = 0.25$	$\lambda_V = 1.065$

In the case of an infinitely thin plate placed crosswise to the air stream, the volume of the blocking body is equal to zero. Considering, however, that a plate placed into the air stream in this manner nevertheless causes a deflection of the streamlines, the coefficient  $\lambda_V$  must tend to  $\infty$ . Turning to the available literature on calculations of flow around a plate (bibl. 5), one will find, for a plate of constant height  $h$  and of very large width  $b$  ( $b/h \rightarrow 0$ ), the equation

$$\lambda_V V = \frac{\pi}{4} h^2 b, \text{ and, for a circular plate with the diameter } d, \text{ the equation } \lambda_V V = \frac{1}{\pi} d^3.$$

\* For cylinders, Glauert represents the equivalent doublet strength as  $M^+ = \lambda b \frac{\pi}{2} d_{\max}^2 v_\infty$  (R & M 1566 p 53). The previously mentioned  $\lambda_V$  value, related to the volume, is thus in the following relationship to Glauert's  $\lambda$ -value:  
 $\lambda_V = \frac{\pi}{2} \frac{d_{\max}^2 b}{V} \lambda$ . For the circular cylinder,  $\lambda = 1$ , and thus  $V=2$ :

and for rotationally symmetrical bodies correspondingly:  $M^+ = \lambda \frac{\pi}{4} d_{\max}^3 v_\infty$  (R & M 1566 p 59) and thus  $\lambda_V = \frac{\pi}{4} \frac{d_{\max}^3}{V} \lambda$ . For the sphere, Glauert

gives the value  $\lambda = 1$ , so that  $\lambda_V = 1.5$ .

## 2. Equivalent Source Strength for Consideration of Wake Blockage behind a Drag Body

It is known that a wake forms behind bodies exposed to an air stream. The wake drag (but not induced drag) causes a loss of energy and obviously increases the blockage caused by the body (fig. 3). This wake originates close to the body and extends downstream to the infinite under increasing mixture with the unseparated flow. It suggests itself to represent the effect of this wake for points of great lateral distance by a system of sources and sinks having their origin at the location of the drag body and deflecting the unseparated flow behind the body in exactly the same measure as the wake blockage. Under certain simplifying conditions, a correlation which can be used as an estimate of wake blockage\* can be established between the yield of this system of sources  $Q$  and the drag caused by the body.

Assuming that the static pressure in the wake differs only little from the pressure of the undisturbed flow and omitting small square terms, the yield of the equivalent source can be expressed as follows:

$$\text{Yield of equivalent source: } Q = \frac{1}{2} v_{\infty} F$$

where  $F = c_w A$ , represents the surface of parasitic drag of the body exposed to flow (without consideration of induced drag). This relation between source yield and surface of equivalent drag is independent of the shape of the body and is valid for two-dimensional flow as well as for three-dimensional flow.

The exact location of this equivalent source is not established unequivocally. It seems permissible, however, to imagine this source as located at the center of

---

\* In accordance with the theorem of momentum, if pressure in the cross section behind the body can be assumed as already being undisturbed, the drag  $D$  caused by a body can be expressed as follows:

$$D = \int dm \Delta v = \int \rho v_1 (v_{\infty} - v_1) df = \rho \int v_1 (v_{\infty} - v_1) df$$

$\Delta v = \text{mass volume of flow per second multiplied by loss of velocity}$

The integral in the last equation indicated exactly the additional volumetric yield  $Q$  of the equivalent source, which, assuming potential flow, deflects the streamlines at a great lateral distance from the wake in the same measure as the

$$\text{wake, i.e., } Q = \int (v_{\infty} - v_1) df \quad \text{or} \quad D = \rho \int v_1 (v_{\infty} - v_1) df$$

By transformation, this can be expressed as:  $Q = \frac{D}{\rho v_{\infty}} = f v_{\infty} / 2$ . The

same relation between source yield and drag has already been stated by Muttray (FB 824/p 32).

gravity of the mass. If this assumption proves to be erroneous, the error will still be rather small as long as the equivalent source is used only for the purpose of representing flow conditions at a great distance from the source. In the case of the intended tunnel correction, this prerequisite is complied with as model dimensions are always small in comparison with the tunnel diameter.

In the formulation of the previously mentioned expression for source yield, it was assumed that the static pressure in the wake differs only little from the pressure of the undisturbed flow. At a great distance behind the drag body, this prerequisite is fairly well complied with so that the previously mentioned equivalent source strength remains very nearly the same although the wake area is constantly widening. Immediately behind the wing, however, the static pressure may differ to a great extent from the pressure of the undisturbed flow so that there are deviations from the afore-mentioned simple relationship between drag and source yield. Muttray demonstrated that source yield decreases rapidly from a maximum at the wing's trailing edge to a constant final value behind the wing (FB 824, Fig. 22). This means that there is an additional system of sources and sinks behind the wing apart from the equivalent source strength previously calculated. At a great distance from the wing, for instance, at the tunnel wall, this additional system of sources and sinks has approximately the effect of a single doublet. The effect of this additional wake doublet is taken into consideration in the following calculations for corrections if the extent of tunnel corrections is determined from the disturbance velocities measured at the wall, in accordance with equation (4). The negligence of the fact that the location of this wake doublet does not coincide with the center of gravity of the profile is rather unimportant, considering the small effect of wake corrections. The same concept can be applied to additional blockage due to shock fronts so that also their approximate effect can be considered in the corrections as long as the length of the shock fronts is small relative to the tunnel diameter.

#### B. Disturbance Velocity at Center Line and at the Wall Due to Model and Wake Blockage

Since it was established that model dimensions are small in comparison to the tunnel diameter, the disturbance velocities at the tunnel walls can be represented by the already defined equivalent doublet and the equivalent source. The border condition with which to be complied, considering the presence of the tunnel wall, is in the case of a closed tunnel: "All velocity components normal to the tunnel wall must disappear."

This requirement is met by superposing over the flow around the model in the free air stream an auxiliary flow strong enough to make the combined flow sufficient to comply with the above-mentioned condition. For a circular wind tunnel, the calculation itself is rather complicated. In the present case the problem was solved with a procedure indicated by Lotz (bibl. 6), based on the determination of the field of radial velocities along the tunnel walls and of the velocity field of the auxiliary flow with the help of a Fourier series. The constants of the velocity field of the auxiliary flow were determined by comparing the coefficients of the two Fourier series so that the velocity could be measured at any point of the field of flow. The velocity induced by the auxiliary flow at the model

location is considered as the necessary correction of velocity.

In this report, the results of this calculation are given exactly for incremental velocities at the tunnel center; for the symmetrical case (arrangement of the equivalent doublet and the equivalent source at the tunnel center); and for incremental velocities at the tunnel wall since calculation with this arrangement is still relatively simple, considering that only the first component of the Fourier series has to be taken into consideration. Figures also are given for several asymmetrical arrangements in which the first four components of the Fourier series enter into the calculation with regard to excessive velocity at the tunnel wall. It remains, however, to be seen if further Fourier components will have a further effect on the results.\*)

### 1. Disturbance Velocity Due to Model Blockage

In accordance with Glauert's formulation, we express the velocity correction for the tunnel center as follows:

$$\frac{\Delta v_x}{v_\infty} = \tau_v \lambda_v \frac{V}{D^3}$$

where  $V$  = volume of the body and

$D$  = tunnel diameter.

As explained previously,  $\lambda_v$  is a factor considering the model shape (fig. 2). The factor  $\tau_v$  depends on the shape of the tunnel and on the ratio between model dimension and tunnel diameter. Table I shows the value of  $\tau_v$  for several typical cases in a closed circular tunnel.

TABLE I

Factor  $\tau_v$  for a closed circular tunnel \*\*)  
(Equation 3)

Model shape	Body of revolution	Rectangular wing				
		B/D=0	B/D=0.25	B/D=0.50	B/D=0.75	B/D=1.00
Factor $\tau_v$	1.020	1.020	1.029	1.058	1.109	1.204 .

B = Span of the rectangular wing

D = Tunnel

\* An additional report will be given if the consideration of higher components of the Fourier series should call for a correction of the indicated figures. This report would also give a detailed description of the method of calculation.

\*\* In R & M 1566/p 58, Glauert presents the factor  $\tau_v$  for rotationally symmetrical bodies (after corresponding conversion) as:  $\tau_v = 0.797 \cdot 4/\pi = 1.016$  in the case of a closed circular tunnel; and as  $\tau_v = -0.206 \cdot 4/\pi = -0.263$  in the case of an open circular tunnel. Deviations of these values from those given in Table I are within the limits of exact calculation.

In the form indicated by Weinig, the incremental velocity at the tunnel center also can be demonstrated as a function of the incremental velocity at the tunnel wall. In the same way, as in the case of two-dimensional flow calculated by Weining, it also can be shown for a closed circular tunnel that the disturbance velocities  $v_{xw}$ , occurring at the tunnel wall in the model plane because of model suspension, are in a definite relation to the disturbance velocities at the tunnel center  $v_x$  (fig. 4). If the arithmetic mean of the velocities above and below the model is taken as the comparative velocity  $v_{xw}$ , this mean value is at first independent of lift since a potential vortex at the model location induces circulatory velocities of equal but opposed strength at these two points. Velocity at the wall is composed of two parts (fig.4): i.e., one part which represents directly the disturbance velocity of the equivalent doublet, and another part caused by the wall effect. Velocity increment at the tunnel center  $\Delta v_x$  can thus be expressed as follows:

$$\frac{\Delta v_x}{v_\infty} = m \frac{\Delta v_{xw}}{v_\infty} \quad (4)$$

Factor  $m$  in this equation depends on the tunnel shape and on the ratio between model dimension and tunnel diameter. For a closed circular tunnel, this factor  $m$  is given in table II for several characteristic cases:

TABLE II

Factor  $m$  for a closed circular tunnel (Equation No.4)

Shape of model	Body of revolution	Rectangular Wing				
		B/D = 0	B/D = .25	B/D = .50	B/D = .75	B/D = 1.00
Factor $m$	0.450	0.450	0.457	0.479	0.520	0.604

B = Span of rectangular wing

D = Tunnel diameter

For the sake of comparison, we want to point out that Weinig arrived at the value of  $m = 1/3$  for a wing of infinite span between two walls. This proves that  $m$  depends to a relatively great extent on the shape of the tunnel.

## 2. Correction Due to Blockage of Models of very Considerable Length

Figures given in the preceding paragraph 1) were calculated with the understanding that all model dimensions (with the exception of wing span) are small in relation to the tunnel diameter. In many cases, however, it is necessary to ascertain to what extent the results would be changed if the afore-mentioned supposition with regard to the model length no longer exists.

To investigate this effect on bodies of revolution at the tunnel center, the incremental velocities at the tunnel center and at the tunnel wall were calculated, as described in paragraph 1,, for source-sink bodies of various lengths.

Distribution of sources and sinks in these bodies is shown in fig. 5. In this arrangement, the completeness of the separating streamline amounts to about

$$A_{\text{profile}} / d \text{ length} = 0.75$$

which corresponds to the conventional shapes of fuselages and wings customary in airplane construction. Since the magnitude of the equivalent doublet is determined easily with the help of equation (1)  $M^+ = \sum (2a Q)$ , the disturbance velocities at the tunnel center and at the tunnel wall can be determined with equal ease with the help of equations (3) and (4) if the effect of great model length is neglected. A comparison of results shows that numerical values for  $\tau_v$  as well as the relationship  $m$  (equations 3 and 4) require correction. This correction is shown in fig. 6. It is seen that incremental velocities at the tunnel center, due to models of very considerable length, differ very little from the value for infinitely small models. Velocity at the tunnel wall and the relationship  $m$  of velocity at the wall and velocity at the center, on the other hand, are affected to a greater extent by model length. In the case of a wing having a chord equal to the tunnel diameter, for example, the velocity at the center decreases to 89% and the velocity at the wall to 66% of the velocities which would result in the case of models of very small chord length.

The previously mentioned investigations of models of great length refer only to rotationally symmetrical bodies and to wings of very small span relative to tunnel diameter. Strictly speaking, it also would be necessary to make corresponding calculations for other ratios of wing span to tunnel diameter. As long as such calculations are not yet available, it may be assumed, however, that the correction data given in fig. 6 represent an acceptable approximation which also would be valid for wings having a finite ratio of wing span to tunnel diameter.

### 3: Disturbance Velocity Due to Wake.

The effect of wake behind a drag body on the tunnel wall and thus also on tunnel correction can be represented approximately by an equivalent source at the model location (see section II, A.2). If the border conditions at the tunnel wall are complied with for this flow pattern by superposing an additional velocity field on the source flow in free air, as per section II, B. 1, it easily is seen that no velocity component will pass through the additional field of flow in the direction of the oncoming flow at the model location in a closed tunnel. It will be only in the case of asymmetrical arrangement of the source in the tunnel that a velocity component perpendicular to the direction of the oncoming flow will be found, thus causing a change of the angle of attack. But even this change of the angle of attack is generally of no importance for test purposes as it is rather improbable that models are suspended asymmetri- cally in the wind tunnel.

Although the additional velocity field does not induce a velocity component in the direction of the oncoming flow at the model location, it will be necessary to correct the velocity of the oncoming flow in a closed tunnel. The actual circumstances are illustrated most clearly in fig. 7, showing a tunnel of unlimited width. The velocity field created by the source in the tunnels and by the exterior

sources reflected at the wall is characterized by the fact that the velocity components in the direction of the oncoming flow disappear in the model area. In the infinitely far distance, upstream and downstream, however, a parallel flow having the velocity  $v = \pm 1/2 Q/A$  develops. For flow within the tunnel very far ahead of the source, this means that the velocity of the oncoming flow is no longer  $v'_\infty$  but  $v_\infty = v'_\infty - 1/2 Q/A$ .

Velocity of the oncoming flow increases up to the model area in the amount of  $\Delta v_x = 1/2 Q/A$  and up to a cross section far behind the body by  $\Delta v = Q/A$ . The desired correction of oncoming flow velocity in a closed tunnel is thus in accordance with equation (2):

$$\frac{\Delta v_x}{v_\infty} = 1/2 \quad \frac{Q}{A \cdot v_\infty} = 1/4 \quad \frac{f}{A} \quad (5)$$

where  $f = C_D S$   $S$  = surface of parasitic drag

$A$  = cross-sectional area of the tunnel

Distribution of this correction velocity along the model cross section is uniform, i.e., velocity increase  $\Delta v_x$  is the same at the center and at the walls of the tunnel. In the equation  $\Delta v_x/v_\infty = m \Delta v_{xw}/v_\infty$ , the factor  $m$  is thus equal to 1 ( $m = 1$ ).

The equation for velocity correction due to model wake (in the same way as the factor  $m$ ) is independent of the shape of the closed tunnel and is thus valid for circular tunnels as well as for square-shaped tunnels, etc.

In the same way it easily can be demonstrated that wind tunnels with open working sections do not require a correction of oncoming flow velocity for consideration of wake blockage.

Similar to fig. 7, the border conditions for the free stream could be complied with by reflecting an alternating system of sources and sinks at the tunnel wall. At the tunnel center there is still no direct velocity component in the direction of oncoming flow. In the infinite distance upstream and downstream from the source area, however, the disturbance velocity due to sources and sinks decreases to zero as the velocities induced by them neutralize each other.

### III. CORRECTION OF ONCOMING FLOW VELOCITY DUE TO MODEL BLOCKAGE AND TO WAKE AT HIGH SUBSONIC VELOCITIES WITHIN THE RANGE OF VALIDITY OF THE PRADTL RULE.

So far, the previously given equations for tunnel correction are valid for incompressible flow only. With the help of the Prandtl rule, however, it is possible to correlate, to a given tunnel and model in compressible flow, a definite other tunnel with models of other dimensions in incompressible flow.

Between the velocities in these two correlated tunnels, there are certain definite relationships which permit conclusions as to the flow in a compressible medium from the flow in an incompressible medium. For this purpose we base our calculation on the following formulation of the Prandtl rule (bibl. 7):

At every point in a compressible flow, there is, in comparison to the corresponding point in the pertinent incompressible flow, the identical potential and the identical velocity in the direction of oncoming flow (x - direction), whereas velocities in the directions perpendicular to the direction of the oncoming flow are decreased by the factor  $\sqrt{1 - M^2}$ . The corresponding points in the two fields of flow are linked to each other by the following equations:

$$x_{inc} = x_{comp}; \quad y_{inc} = \sqrt{1 - M^2} \cdot y_{comp};$$

$$z_{inc} = \sqrt{1 - M^2} \cdot z_{comp};$$

$$M = \frac{\text{velocity of undisturbed flow}}{\text{speed of sound}} = \text{Mach number}$$

#### A. Model Blockage

Fig. 8 demonstrates the potential field in incompressible flow in a closed tunnel for a wing of great aspect ratio  $b/c$ . The model is assumed to be so slender and to possess a sufficiently sharp-edged nose that the Prandtl rule is complied with along the entire outline of the profile. The outline of the profile is defined by the separating streamline of a given system of sources and sinks so that the potential lines reach into the space surrounded by the separating streamline. It is noteworthy that the potential lines  $\phi = \text{constant}$  must intersect the tunnel wall and profile surface perpendicularly, since there are no normal velocity components at these boundary surfaces.

If this field of potential lines is converted in accordance with the Prandtl rule, i.e., if the lines  $\phi = \text{constant}$  are drawn apart in the direction of the y-axis and the z-axis to the extent of  $1/\sqrt{1 - M^2}$ , retaining the x-components, a new potential field for compressible flow is arrived at (fig. 8). This distorted potential field shows that the condition for the tunnel wall, "All potential lines must run perpendicular to the direction of the oncoming flow" is complied with along a new contour, the y- and z- coordinates of which have increased by the factor  $1/\sqrt{1 - M^2}$ .

In circular tunnels, for instance, this means that the tunnel diameter in compressible flow is  $1/\sqrt{1 - M^2}$  times larger than that of the comparative tunnel in incompressible flow.

By conversion in accordance with the Prandtl rule, the wing suspended in the tunnel also undergoes certain changes. If the assumption is made, for a body of slender shape, that the potential lines within the space surrounded by the separating streamline (substituting for the body) can be replaced by their tangents at their points of intersection with the x-axis, we see that the distortion causes the slope of these tangents to be steeper in the ratio of  $1/\sqrt{1 - M^2}$ . This, however, means that close to the x-axis the streamlines and especially the separating streamlines have a  $\sqrt{1 - M^2}$  times flatter inclination  $dy/dx$  than before the distortion.

The profile outline, defined to be the separating streamline, is thus  $\sqrt{1 - M^2}$  times thinner after conversion. Wing span of a wing with a great span/chord ratio  $B/t$  is determined by the length of the section covered by sources and sinks or by doublets. This section increases by distortion in the ratio of  $1/\sqrt{1 - M^2}$ , and, as a result, the span of the comparative wing in compressible flow is  $1/\sqrt{1 - M^2}$  times larger.

Since conversion makes the profile section more slender in the ratio of  $1/\sqrt{1 - M^2}$  and, on the other hand, increases the wing span in the same ratio, the reference wing and the pertinent wing in compressible flow have an identical volume. For slender bodies of revolution, it likewise is known that conversion in accordance with the Prandtl rule does not change their outline in the first approximation, and, therefore, the volume in this case also remains unchanged (see F.B. 1165).

Velocity components in the direction of oncoming flow are not changed by conversion, which fact is also valid for velocity components caused by the model or by the tunnel wall. Velocity corrections in the direction of the oncoming flow for a body in compressible flow are therefore the same as those for a body, converted as explained above, in incompressible flow in a tunnel decreased by the factor  $\sqrt{1 - M^2}$ .

If a model, which at low velocities requires a correction of oncoming flow velocity amounting to  $(\Delta v_x / V_\infty)$  inclusive, is exposed to a flow of a higher Mach number in a closed wind tunnel, the required velocity correction increases in accordance with equation 3, in the ratio of  $1/(1 - M^2)^{3/2}$ , i.e.

$$\frac{\Delta v_x}{v_\infty \text{ comp}} = \frac{1}{(1 - M^2)^{3/2}} \cdot \frac{\Delta v_x}{v_\infty \text{ inc}} \quad (6)$$

In the afore-mentioned relation, it was assumed that the factors  $\lambda_v$  and  $\tau_v$  contained in equation (3), are not changed by conversion in accordance with the Prandtl rule. In the case of  $\lambda_v$ , there is actually a small variation due to the change of the effective thickness ratio. According to fig. 2, however,  $\lambda_v$  is affected by the thickness ratio only to a small degree, and, therefore, changes of  $\lambda_v$  generally can be neglected without the risk of a major error.

The factor  $\tau_v$  does not change as long as model length can be considered as small relative to tunnel diameter. With progressively rising Mach numbers, however, the effective ratio between model length and tunnel diameter increases by  $1/\sqrt{1 - M^2}$  as the model length remains unchanged, whereas the tunnel diameter shrinks in the ratio of  $1/\sqrt{1 - M^2}$ . At increasing Mach numbers, the correction of exceedingly long models in a closed tunnel is therefore of major importance. As per fig. 6, it is possible to estimate the correction of the factor  $\tau_v$  by increasing the effective ratio of model length to tunnel diameter by  $1/\sqrt{1 - M^2}$ .

Factor  $m$  contained in equation (3) remains unchanged as long as the ratio model length/tunnel diameter can be considered as being small, since this ratio is identical for both the comparative and the reference tunnel after conversion in accordance with the Prandtl rule, so that the figures given for factor  $m$  in Table II must be applied to both systems. However, if conversion leads to higher ratios

for model length/tunnel diameter, the value for  $m$  must be corrected as shown in fig. 6.

## B. Incremental Velocities Due to Wake

The method of calculation used for correction of oncoming flow velocity due to model blockage can be applied to additional blockage due to wake in the same manner. Assuming that the drag surface does not change at increased velocity of the oncoming flow, we can formulate as follows: (with reference to equation (5) )

$$\frac{\Delta v_x}{v_\infty} \text{ comp} = \frac{1}{1 - M^2} \times \frac{\Delta v_x}{v_\infty} \text{ inclusive} \quad (7)$$

Contrary to the cases discussed so far, it will be noted that the tunnel correction does not increase in the ratio of  $1/(1 - M^2)^{3/2}$ , but in the ratio of  $1/(1 - M^2)$ . In this calculation the wake effect has been substituted by flow around a source, which, in a parallel flow, creates a separating streamline in the form of a semibody. The above-mentioned result would thus mean:

For a body of small length, e.g., a fuselage in a tunnel, the corrections of oncoming flow velocity increase in the ratio of  $1/(1 - M^2)^{3/2}$ .

For a semibody in a closed tunnel, the corrections of oncoming flow velocity increase only in the ratio of  $1/(1 - M^2)$ .

**The reasons** for this different behavior of the two body shapes are as follows: In rotationally symmetrical flow, the radial velocities acting on the tunnel wall decrease, at points located a small distance upstream or downstream from the model in the case of short bodies (equivalent doublet), approximately in the inverse ratio of the fourth power of the distance from the body. In the case of a semibody (equivalent source), however, the velocities decrease only in the inverse ratio of the second power of the distance from the body. If, in accordance with the Prandtl rule, the tunnel diameter is decreased (in incompressible flow) to the same extent for both body shapes, it is easily understood that the wall effect will increase in the case of a semibody to a lesser degree than in the case of a short body.\*)

---

\*) As per this demonstration, the radial velocities of source and doublet decrease at small  $x$ -values as the second and fourth power of  $R$  respectively, whereas the incremental velocities increase as the second and third power of  $1/\sqrt{1 - M^2}$  respectively. The difference in the ratio of power exponents must be attributed to the fact that at a great distance behind and ahead of the source and the doublet, the radial velocities in both cases change to the same extent, which causes an assimilation of the power exponents.

For the semibody, a simple controlling calculation of the degree of velocity increase is possible. If a semibody is placed in a closed tunnel, there is a parallel flow far behind and far ahead of its tip. The velocity increase can be calculated easily from the amount of constriction of the cross section  $dA$ . (Foot note continued on next page)

If the correction of the oncoming flow velocity is brought in relation to the velocity at the wall, we find, in the range of validity of the Prandtl rule, that the factor  $m$  in equation (4) is still  $m = 1$  since this factor is independent of the tunnel diameter for the calculation of wake blockage.

---

\*)

From the equations

$$\frac{dp}{F} = \gamma \frac{M^2}{1 - M^2} \times \frac{dA}{A} \quad \text{and} \quad \frac{dp}{P} = - \gamma M^2 \frac{dv}{V}$$

we find, in accordance of the afore-mentioned relation derived from the Prandtl rule:

$$\frac{dv}{V} = - \frac{1}{1 - M^2} \times \frac{dA}{A}$$

IV. CORRECTION OF ONCOMING FLOW VELOCITY DUE TO MODEL BLOCKAGE  
AND TO WAKE AFTER THE PRANDTL RULE NO LONGER  
APPLIES IN THE VICINITY OF THE MODEL.

It is a prerequisite for validity of the Prandtl rule that incremental velocities resulting from the body exposed to flow are small relative to the velocity of the oncoming flow. In many cases, especially at high Mach numbers, this prerequisite is no longer complied with along the body surface. At a certain distance from the body or from the flow singularity, the incremental velocities already have decreased sufficiently to again apply the Prandtl rule to flow outside a definite area (bibl. 8). In fig. 9, for instance, it is only within an area defined by the boundary line that the Prandtl rule is not applicable, and, as a result, it is only for streamlines in this area and for the outline of the body that the law of conversion is not known.

Beginning with the most elementary case of flow in an infinitely wide tunnel with parallel walls, this perception will now be applied to flow in a tunnel. In compressible flow, the boundary conditions at the tunnel walls are complied with for a doublet substituting for a body by infinitely repeated reflection of the equivalent doublet at the tunnel wall. In the vicinity of the doublet, the disturbance velocities are so great that the Prandtl rule is not applicable in a certain limited area (fig. 10). Conversion of this incompressible field of flow in accordance with the Prandtl rule, however, is only possible for the areas outside the limiting line. The area within the limiting line must be converted in accordance with a rule not known at this stage of research, and, consequently, the body outline for compressible flow is equally unknown. As per Prandtl's rule, it is thus no longer possible to calculate the strength of an equivalent doublet for a given body. In a wind-tunnel test, however, this can be remedied by means of a simple measurement. Considering that the incremental velocity at the tunnel wall, prevailing above and below the model respectively, represents a measure of the effective doublet strength, and further considering that the tunnel walls are already within the validity range of the Prandtl rule, a measurement of the wall velocity permits conclusion as to the effective strength of the equivalent doublet. The desired velocity correction at the center line is the sum total of the induced velocities of all reflected doublets, the strength of which are known from the measurement of wall velocity. For these velocities, the tunnel center is once more within the validity range of the Prandtl rule. Between wall velocity and correction of oncoming flow at the tunnel center, there is the same relation as that prevailing within the unrestricted validity range of the Prandtl rule, i. e.,

$$\frac{\Delta v_x}{V_\infty} = m \times \frac{\Delta v_{xw}}{V_\infty}$$

This relation is not restricted to flow between two walls. It can be applied easily to a closed tunnel of any cross-sectional shape, e.g., also to a circular tunnel. The only difference is that for flow between two walls, the additional potential for compliance with the wall conditions is created by the reflected singularities; whereas, in the most general case, the additional potential also originates from singularities outside the tunnel. However, location and strength of these singularities cannot be found by mere reflection.

As long as model dimensions are small relative to tunnel diameter, the factor  $m$  is equal to the values given in table II. For models of great length and for high Mach numbers, it will be necessary to estimate correction of the factor  $m$  in accordance with fig. 6, considering the very large ratio between model length and tunnel diameter.

The indicated relation between velocity at the wall and velocity of the oncoming flow for flow around models in the vicinity of which the Prandtl rule is no longer valid also can be applied to velocities induced by wake.

The above-described extension of calculations for tunnel corrections to Mach numbers at which the Prandtl rule is no longer valid in the vicinity of the model is, of course, not applicable without any restrictions up to  $M = 1$ . An upper limit of applicability is given if the velocity at the wall reaches or exceeds the speed of sound. In this border line case, the prerequisites of the Prandtl rule are already nonexistent in the vicinity of the tunnel wall, thus nullifying the entire method of conversion. How close this upper limit may be approached in wind-tunnel tests without creating a fundamental change of the pressure field around the profile can be determined only empirically. This boundary Mach number, among other factors, will depend on the angle of incidence of the model. Tests to determine permissible model dimensions at certain boundary Mach numbers and angles of incidence are conducted and evaluated at the DVL at the present time.

## V. TUNNEL CORRECTIONS DUE TO LIFT AT HIGH SUBSONIC VELOCITIES

### A. Wing in Free Air Stream

For a brief survey of flow conditions around a wing with lift in a compressible medium, we shall first consider the case of vortex filaments substituting for a wing in free air. The field of flow around a potential vortex in incompressible flow is demonstrated in fig. 11. If the velocities within the area limited by the line ABCD are summed up, the following integral expresses the calculation of the vortex:

$$\oint v \times ds = \Gamma = \text{circulation}$$

It is known that magnitude of the circulation does not depend on the path of integration as long as the vortex stays within the limiting line. In a medium of constant density, the lift per unit of length can thus be expressed as:

$$L' = \rho \int \Gamma v_{\infty} \quad \text{where}$$

$$\rho = \text{air density}$$

If the flow pattern of this vortex is converted in accordance with the Prandtl rule (excluding the area in the immediate vicinity of the vortex core), the control area ABCD is drawn out in the direction of the y-axis (fig. 11). At the same time, the velocity components  $v_y$  are reduced at the corresponding points in the ratio of  $1/\sqrt{1 - M^2}$ , so that the product of "Path element multiplied by Velocity" at the vertical limiting lines is not changed by the conversion. Since, on the other hand, neither lengths nor velocities have undergone any change in the x-direction, the circulation integral along the control lines ABCD and A'B'C'D' remains unchanged. If the control lines A'B'C'D' are imagined as being located at a great distance from the vortex, where disturbance velocities and thus also the pressure and density variations in the flow have decreased to infinitely small values, the compressible flow in the vicinity of the control lines is entirely equal to an incompressible flow. This means that there is once more the already known relation for lift per unit of length, viz:

$$L' = \rho V_\infty \Gamma$$

where  $\rho$  is the density of the flowing medium at a great distance from the vortex.

From the afore-mentioned consideration, we draw the conclusion that circulation as well as lift relative to wing span are not changed by conversion as per Prandtl.

In compressible flow, the same amount of lift per wing span element is achieved with a  $\sqrt{1 - M^2}$  times smaller angle of attack. This fact is recognized when considering that in the case of conversion the velocity components perpendicular to the direction of oncoming flow are decreased, whereas the components in the direction of the oncoming flow remain unchanged. The inclination of the streamlines and thus also the angle of attack decrease in the same ratio.

The same consideration can be applied to a wing of finite span and elliptical distribution of lift. In this case a wing in compressible flow is comparable to a wing in incompressible flow having a span  $\sqrt{1 - M^2}$  times smaller. At each section in corresponding distances from the wing's center section, circulation and lift per unit of span element are the same for the two wings with elliptical distribution of lift, whereas the geometrical as well as the induced angles of attack in compressible flow are increased in the ratio of  $1/\sqrt{1 - M^2}$ . The comparative wing in incompressible flow has, in this case, a  $\sqrt{1 - M^2}$  times less favorable aspect ratio. The equation for induced drag in compressible flow

$$C_{Di} = C_L \times \Delta \alpha_i = \frac{C_L^2}{\pi} \times \frac{S}{b^2} = \frac{C_L^2}{\pi R}$$

S = wing area in compressible flow      b = wing span in compressible flow  
R = aspect ratio

nevertheless remains the same since the induced angle of attack of the comparative wing in compressible flow is  $\sqrt{1 - M^2}$  times larger but, on the other hand, is reduced  $\sqrt{1 - M^2}$  times by conversion to compressible flow. Both effects thus neutralize each

other. The equations for the induced angle of attack  $\Delta\alpha_i = \frac{C_L}{\pi} \times \frac{S}{b^2}$  and the induced drag  $C_{Di} = \frac{C_L^2}{\pi} \times \frac{S}{b^2}$  are thus also valid for compressible flow.

### B. Wing with Lift in Wind Tunnel

In previous sections we have stated repeatedly that a wing in a tunnel with compressible flow can be correlated to a wing with equal lift in a similarly reduced tunnel with incompressible flow. Between the velocity corrections of the comparative and the reference tunnel, there is in this case the relation that the  $v_y$  corrections in compressible flow must be reduced in the ratio of  $1/\sqrt{1-M^2}$ . In this manner all available calculations of corrections also can be applied to compressible flow.

The results of available calculations of tunnel corrections are generally expressed in the following form:

correction of angle of attack

$$\Delta\alpha = \mathcal{f} \times \frac{C_L}{\pi} \times \frac{S}{A} \quad \text{where}$$

$\mathcal{f}$  = correction coefficient = function of wing span/tunnel diameter, shape of tunnel, and lift distribution

$S$  = wing area       $A$  = cross section of tunnel

By conversion in accordance with the Prandtl rule, the value of the factor  $\mathcal{f}$  is not changed since the ratio of wing span tunnel diameter as well as the shape of the tunnel and the lift distribution which determine the magnitude of this factor, remain the same. The wing surface, however, is decreased in the ratio of  $1/\sqrt{1-M^2}$  and the cross-sectional tunnel surface even by  $(1-M^2)$ ; in the comparative tunnel with incompressible flow, the correction of the angle of attack consequently is increased in the ratio of  $1/\sqrt{1-M^2}$ . On reduction to compressible flow, however, this increase is neutralized since all velocities and angles of attack are decreased  $\sqrt{1-M^2}$ -fold by conversion in accordance with the Prandtl rule.

It is therefore a noteworthy fact that in the case of elliptical distribution of lift, corrections of the angle of attack and thus also corrections of induced drag can be considered in the same way as in incompressible flow.

It is, however, a prerequisite for this general statement that wing dimensions (with the exception of wing span) are small relative to tunnel diameter and that corrections are considered only at the location of the wing. If this prerequisite is no longer complied with, as in the case of correction of a wing of considerable chord length due to jet curvature in the wind tunnel or for calculation of downwash behind a wing, it will be expedient to return to the conception of the comparative tunnel, determining corrections corresponding to the latter one. In this case, for instance, the correction of wings of great chord length due to jet curvature increases in the ratio of  $1/\sqrt{1-M^2}$ . The ratio between chord and tunnel diameter therefore also increases at progressing Mach numbers in the comparative tunnel. At high Mach

numbers; corrections due to jet curvatures thus can be rather important, whereas they would still be entirely negligible in compressible flow.

## VI. APPLICATION OF THE ABOVE-MENTIONED WIND-TUNNEL CORRECTIONS

### A. Possibility of Superposition of the Individual Corrections

The various factors considered in wind-tunnel corrections, such as model blockage, wake blockage, and lift, so far have been dealt with as if only one of these factors would be effective at the time e.g., the blocking body without lift and drag or a supporting vortex with and without blockage, etc. In wind-tunnel tests, however, the individual effects generally occur together, so that there arises the question of superposing the individual corrections.

For incompressible flow, this question can be answered immediately by superposing the individual effects linearly. Each individual correction can be calculated from the pertinent potential field. Since the potentials in compressible flow can be superposed linearly, the corrections derived from them also can be superposed linearly in the same way.

With the help of the Prandtl rule, we correlated to each flow pattern in compressible flow a corresponding flow pattern in incompressible flow. Between velocities and angles of attack of the two fields of flow, there are the already-known relations expressed by the Prandtl rule. In the comparative field of incompressible flow, the individual effects and corrections once more can be superposed linearly. Considering that the desired corrections for compressible flow differ from these comparative corrections only with regard to one factor, the law expressing the possibility of linear superposition of individual corrections is equally valid for compressible flow.

### B. Application of Corrections to Wind-tunnel Tests

1. Corrections due to lift are figured in accordance with the pertinent equations corresponding to the amount of lift established by measurement. With equal lift coefficient, the corrections do not increase with rising Mach numbers as long as the ratio of model length/tunnel diameter also remains small in the comparative tunnel. In the case of long models, the corrections due to jet curvature, however, increase at rising Mach numbers in the ratio of  $1/\sqrt{1 - M^2}$ , and, as a result, these corrections may be of importance while they were still entirely negligible in incompressible flow.

2. Corrections due to drag established by measurement are calculated in accordance with equations (5) and (7). Assuming the same surface of parasitic drag,  $f = C_D \times S$ , they increase in the ratio of  $1/(1 - M^2)$ .

3. Corrections due to model blockage are estimated at low Mach numbers in accordance with equations (3) and (6) as long as it may be assumed that the prerequisites of the Prandtl rule are fulfilled with sufficient accuracy, including also the circumference of the body. The corrections increase in the ratio of  $1/(1 - M^2)^{3/2}$ . If at high Mach numbers the Prandtl rule is no longer valid in the vicinity of the model, we derive the correction velocity at the tunnel center from the incremental velocity measured at the wall below or above the model respectively, with the help of equations (3) and (4), and the factor  $m$  as per table II. In this calculation, that part which is due to drag must be deducted from the incremental velocity measured at the wall since this correction already has been taken into consideration. The effect of suspension, of course, also must be considered. This is usually accomplished by making a calibration measurement.

For high Mach numbers, all of the afore-mentioned corrections are based on measured values taken at a great distance from the model or on measurements retaining, at such distance, the same value as in the vicinity of the model. Considering that the prerequisites of the Prandtl rule used for these calculations are fulfilled with reasonable accuracy at relatively large distances from the model, the indicated corrections are still considered valid even though the Prandtl rule is no longer valid in the vicinity of the model.

**C. Exemplifying Calculations and Comparison with the Approximations of Ferri and Lamla**

The afore-mentioned equations for corrections of the oncoming flow due to model blockage represent a higher degree of approximation than those of Ferri and Lamla. In an endeavor to estimate the validity of the assumptions made by Ferri and Lamla, we present a comparison of the respective approximations for several examples.

**Table III:** Velocity correction in various wind tunnels for a wing with an elliptical cross section and a thickness/chord ratio of 0.10 at  $M = 0.75$

Type of tunnel	Thickness of wing Height of tunnel	Wing span Width of tunnel	Velocity correction
Closed tunnel with parallel walls $h = \text{constant}$ $b \text{ (width)} \rightarrow \infty$	4%	1	11.4% as per Ferri 4.2% " " Lamla 2.5% " " Franke/ Weinig and Glauert/ Goethert respectively
Open free jet with parallel wall $h = \text{constant}$ $b \text{ (width)} \rightarrow \infty$	4%	1	-4.2%, as per Lamla -1.3% " " Glauert/ Goethert
Closed circular tunnel	4%	0.25	1.2% as per Goethert

As it was to be expected, we see from the figures in table III that Ferri overestimated the wind-tunnel corrections to a great extent. Also Lamla's values, especially those calculated for a tunnel with an open test section, are still considerably higher than the more accurate values of Franke and Weinig and of Glauert and Goethert.

A comparison of the closed circular tunnel and the closed tunnel with plane walls shows that corrections differ widely even if the ratio between model length and tunnel height is the same.

#### D. Application of the Adiabatic Equation to Wind-tunnel Corrections

For correction of dynamic pressure and Mach number, we present various important relations gained from the adiabatic equation as follows:

$$\begin{aligned} \text{correction of dynamic pressure:} \quad \frac{dq}{q} &= (2-M^2) \quad \times \quad \frac{dv}{v} \\ &= -\frac{1}{2} (2-M^2) \quad \times \quad \frac{dp}{p} \end{aligned}$$

$$\begin{aligned} \text{correction of Mach number} \quad \frac{dM}{M} &= \left(1 + \frac{\gamma-1}{2} \times M^2\right) \frac{dv}{v} \\ &= -\frac{1}{2} \left(1 + \frac{\gamma-1}{2} \times M^2\right) \frac{dp}{q} \end{aligned}$$

where  $p$  = static pressure

$$q = \frac{\rho}{2} v^2 = \text{dynamic pressure}$$

$v$  = velocity

$\gamma = 1.405$  for air

Value of the expression  $\left(1 + \frac{\gamma-1}{2} \times M^2\right)$  is demonstrated in fig. 12.

Fig. 13 also presents the figures  $\sqrt{1-M^2}$ ,  $1-M^2$ , and  $(1-M^2)^{3/2}$ , which were used repeatedly in calculations for conversion.

### VII COMPARISON OF CALCULATED CORRECTIONS WITH WIND-TUNNEL TESTS

The high-speed wind tunnel of the DVL was at our disposal to check the determined tunnel corrections at high subsonic velocities. This wind tunnel has a closed test section of 2.7 m diameter and reaches sonic speed in the test section at approximately 50% of the available power.

### A. Variations of Wall Pressure Due to Suspension of Rectangular Wings of Varying Chord Length

To determine the effect of the tunnel walls on the measured values at high subsonic speeds, four rectangular wings of the same profile (NACA 0015-64) but with different chord lengths were tested in this wind tunnel. The chord lengths were  $c = 350, 500, 700, \text{ and } 1000$  mm respectively. The wing span  $b = 1.35$  m and the modes of suspension were the same for all of the four wings. Incremental velocities created by the tunnel walls, however, cannot be measured directly if models are suspended in the tunnel. At best, it would be possible to compare the increase of surface pressures at various Mach numbers as far as changes of surface pressures in the free airstream at high subsonic velocities might be considered as known through any kind of calculations. But even in this case, the observed increase of surface pressures would have to be attributed partly to the effect of compressibility on flow around the profile and partly to the effect of the tunnel wall. This renders a conclusion with regard to the share of the tunnel wall as, for instance, by splitting the calculated test values, rather inaccurate.

Measurement of wall pressure in the model plane, however, affords a serviceable possibility of checking on calculations of velocity corrections. Calculation of wall pressure is based on the same assumptions as calculation of correction velocities at the tunnel center, as explained in the preceding sections. This close relationship, for instance, also is demonstrated by the fact that pressure variations measured at the wall, and due to the model, are in a very definite relation to correction velocities at the tunnel center (see equation (4)). Pressure variations at the tunnel wall, moreover, are always greater than pressure variations at the tunnel center entering into the calculation of correction velocity. Accurate measurement of wall pressure therefore is effected more easily. Measurements were made at varying dynamic pressures, measuring wall pressures  $p_I$ ,  $p_{III}$ , and  $p_w$  (fig. 14). Measuring points for pressures  $p_I$  and  $p_{III}$  were distributed uniformly along the entire cross section. For the measuring of  $p_w$  in the test section, the wall was punctured in the model plane above and below the model at three points located closely to each other and interconnected to furnish a value representing the arithmetic mean. It is demonstrated easily that dynamic pressure and Mach number in the model plane as well as wall pressure  $p_w$  without model installation are merely functions of the ratio  $(p_I - p_{III}) / p_I$ . These relationships were determined in tests and have been established in the form of calibration curves. The values for dynamic pressure and Mach number determined in this manner are hereafter referred to as uncorrected test-section values. If a model is suspended in the test section and if the pressure ratio  $(p_I - p_{III}) / p_I$  is unchanged, the indicated wall pressure  $p_w$  changes. From this change of wall pressure, the necessary corrections can be derived with the help of the previously explained correction calculations.

Wall-pressure changes measured for the four wings of various chord lengths are shown in fig. 15 as a function of the corrected Mach number prevailing at the center of the test section. To eliminate the effect of model suspension, the

wall-pressure change was not plotted relative to wall pressure in the free test section, but relative to wall pressure prevailing with installation of a wing of 350 mm chord length. To facilitate a comparison by calculation, it was assumed that the Prandtl rule was equally valid without limitation in the vicinity of the model. Although this assumption no longer can be correct if compression shocks occur near the model, i.e., in the case of the test wing at Mach numbers of about  $M = 0.76$  and up, nevertheless it should be possible to conclude from the trend of measured and calculated curves as to the validity of the formulations used in our calculations. This is true for the majority of the curves below the critical Mach number of  $M = 0.76$ . Calculations of wall-pressure changes were made with the help of equations (3), (5), (6), and (7) and tables I and II with and without consideration of the measured wing drag. Tests with these wings showed that wing drag becomes a factor of significance only if it increases considerably as a consequence of compression shocks. Even then its effect is of minor importance so that errors with regard to wing drag should not have any major effect on corrections.

The effective Mach number for calculation of the wall-pressure increase, especially at high Mach numbers, is not established unequivocally. The Prandtl rule calls for insertion of the mean Mach number of the flow pattern under consideration. To show the effect of this inaccuracy, the curves were calculated first for the corrected Mach numbers at the tunnel center, which must be considered at any rate as too small in the vicinity of the model. A second calculation was based on the Mach numbers prevailing at the tunnel wall, which should come closer to the mean Mach number in the vicinity of the body. The overall picture shown in fig. 15 demonstrates that the calculated curves represent the course of the measuring points fairly well. The existing deviations are definitely within the range of possible errors. This could be attributed to inaccurate estimation of the effective Mach number.

It therefore may be said that calculations and measurements definitely agree to the extent which could be expected in view of the assumptions made.

With reference to the afore-mentioned uncertain determination of the effective Mach number, it may be pointed out that this uncertainty does not exist for corrections of dynamic pressure and Mach number. The main effect, i.e., the ratio between measured wall-pressure variation and tunnel correction, does not depend on the Mach number prevailing at any certain time. The Mach number figures only in the determination of the correction factors  $m_{\text{corr}}/m$  and  $\tau_v \text{ corr}/\tau_v$  for models of great length and for the consideration of wake blockage. Errors in calculation resulting from uncertainties in these corrections should be rather unimportant in view of the small extent of wind tunnel corrections.

#### B. Effect of Lift on Wall Pressures

The previously described measurements on rectangular wings were made at symmetrical flow against the wing, i.e., at zero lift. In accordance with section II, B., 1), a change of the angle of attack will not affect the mean wall pressure in the first approximation. At the ceiling and at the bottom of the tunnel, the circulation due to lift creates velocity and pressure changes of equal magnitude but of opposite

sign, and , as a result, the disturbance velocity caused by circulation can be eliminated in the formation of a mean value for wall pressures at the ceiling and at the bottom. A change of the angle of attack will affect merely the wing drag, which will be rather unimportant considering the small effect of wing drag on wind-tunnel corrections.

These facts were proved by tests. Fig. 16 shows the wall pressure  $p_w$  for a rectangular wing of 500 mm chord length at wing settings of  $0^\circ$  and  $5^\circ$ , relative to the previously described pressure difference  $p_I - p_{III}$ . It can be seen that there are no systematical deviations between the test points pertaining to the respective wing settings. This cannot be attributed to erroneous measurements. A wing setting of  $5^\circ$  is the limit of practical wind-tunnel tests at high Mach numbers.

This independence of the angle of attack represents a considerable simplification in evaluation of these tests since the calibration curves for dynamic pressure and Mach number do not have to be corrected individually for each separate angle of attack.

### C. Pressure Drop in the Test Section Due to Wake Blockage

As a check on equations (5) and (7) for consideration of wake behind a drag body, we have utilized the fact referred to in section II, B., 3) that the disturbance velocity due to wake at a great distance behind a drag body is exactly twice as great as the corrections calculated for the location of the wing according to equation (5). It furthermore was assumed that this final value was practically achieved at a distance of about two wing-chord lengths behind the test wing of a 500 mm chord length. Based on these assumptions, the additional pressure drop due to wake in comparison with the test section without models could be estimated by calculation. For the effective Mach number, we calculated once more with two values, namely, first with the Mach number corresponding to the center of the test section, and secondly with the Mach number corresponding to the end of the test section.

In this comparison, shown in fig. 17, the measured values are satisfactorily within the range of the calculated curves. The deviations can be attributed to erroneous calculation or to deviations of the effective Mach number.

## VIII SUMMARY

A. Wind-tunnel corrections due to model blockage are calculated for wings having a finite ratio between span and tunnel diameter and for bodies of revolution in incompressible flow in a closed circular tunnel.

Contrary to Glauert, the corrections are given as a function of the volume of the drag body. For slender bodies, the effect of the outline of the body is in this case infinitely small. Especially in the border-line case of a very slender body, the same shape factor results for two-dimensional and three-dimensional flow.

B. The additional corrections due to wake behind a drag body in incompressible flow are represented by a simple equation.

C. With the help of the Prandtl rule, it is demonstrated that tunnel corrections due to model blockage in compressible flow increase in the ratio  $1 / (1 - M^2)^{3/2}$ , and that tunnel corrections due to wake increase with an equal drag surface in the ratio of  $1 / (1 - M^2)$ . At equal lift coefficient, corrections due to lift remain unchanged as long as the wing chord is small relative to the tunnel diameter.

D. With increasing Mach number, the corrections due to jet curvature for models of great length increase in the ratio of  $1 / \sqrt{1 - M^2}$ , so that these corrections may be rather important at high Mach numbers, whereas they were still negligible at low Mach numbers.

E. The corrections derived for high Mach numbers retain their validity even if the prerequisites of the Prandtl rule are no longer complied with along the model surface. The limiting Mach number up to which this procedure can be applied is to be determined in wind-tunnel tests.

F. A comparison between calculation and measurement shows good agreement as far as can be expected in view of the necessary assumptions of a comparative calculation.

## Bibliography

1. Ferri " Untersuchungen und Versuche im Ueberschallwindkanal zu Guidonia" (Research and Tests in the Supersonic Wind Tunnel at Guidonia" ), Jahrbuch der Deutschen Luftfahrtforschung (1938) (Ergaenzungsband), p 112.
2. Lamla " Der Einfluss der Strahlgrenze in Hochgeschwindigkeits-Windkanaelen" (The Effect of Jet Boundary in High-Speed Wind Tunnels), FB 1007.
3. Glauert, H. " Wind-Tunnel Interference on Wings, Bodies and Airscrews" , ARC-Rep a. Mem. 1566, pp 54 - 58.
4. Franke and Weinig " Die Korrektur der Anstroemgeschwindigkeit und des Austroemwinkels in einem Hochgeschwindigkeits-Windkanal mit geschlossener Messtrecke infolge der Verdraengungsstroemung an Tragfluegelmodellen" (Correction of Flow Velocity with Closed Test Section due to Flow Blockage at Wing Models), FB 1171.
5. Fuchs and Hopf Lamb " Sehr breite Platte" (Very Wide Plate) Aerodynamik (1922) p 71.  
" Kreisrunde Platte" (Circular Plate) Hydrodynamik, 107/108.
6. Lotz, J. " Korrektur des Abwindes in Windkanaelen mit Kreisrunden oder Elliptischen Querschnitten" (Correction of Down Wash in Wind Tunnels with Circular or Elliptical Cross Section), Lufo, vol. 12, (1935) page 250.
7. Goethert, B. " Einige Bemerkungen zur Prandtl' schen Regel in Bezug auf ebene und raeumliche Stroemung (ohne Auftrieb)" [Notes on the Prandtl Rule with Reference to Two-Dimensional and Three-Dimensional Flow (Zero Lift)]  
  
FB 1165.
8. Prandtl Franke and Weinig " Volgatagung 1935 Tagungsbericht" (Volta Convention 1935, Convention Report), pp 175 - 177.  
FB 1171.

Windkanalkorrekturen bei hohen  
Unterschallgeschwindigkeiten unter  
besonderer Beruecksichtigung des  
geschlossenen Kreiskanals  
Deutsche Versuchsanstalt fuer  
Luftfahrt, E. V.  
Institut fuer Aerodynamik, FB 1216

Berlin-Adlershof, 16 May 1940  
47 pp, 20 illustrations

Translated by Central Air Documents Office

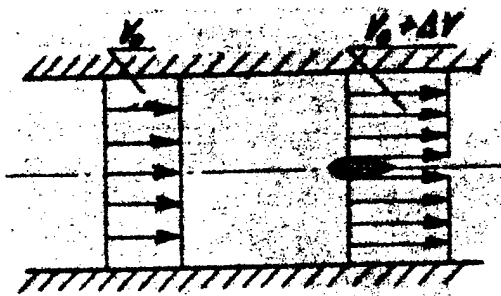

Fig. 1 - Wind Tunnel with Model.  
One-Dimensional Velocity  
Distribution According  
to Ferri

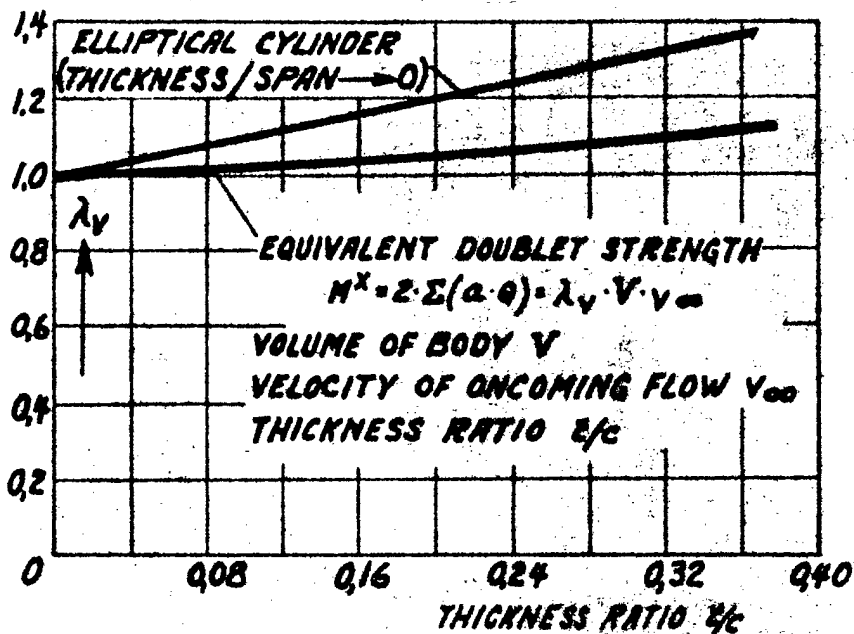

Fig. 2 - Equivalent Doublet Strength for Elliptical  
Cylinder and Ellipsoid Converted as per  
Glauert R & M 1566

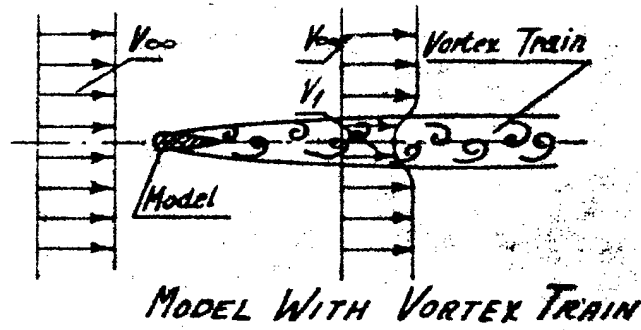

Fig. 3 - Model with Vortex Train

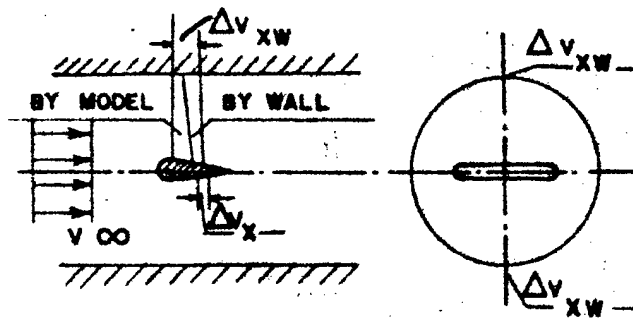

Fig. 4 - Velocity Distribution in the Case of a Model in the Wind Tunnel

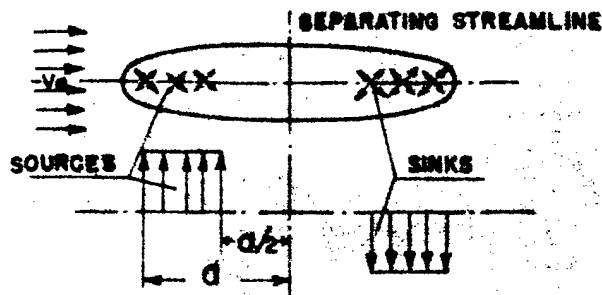

Fig. 5 - Distribution of Sources and Sinks of the Separating Streamlines Under Consideration

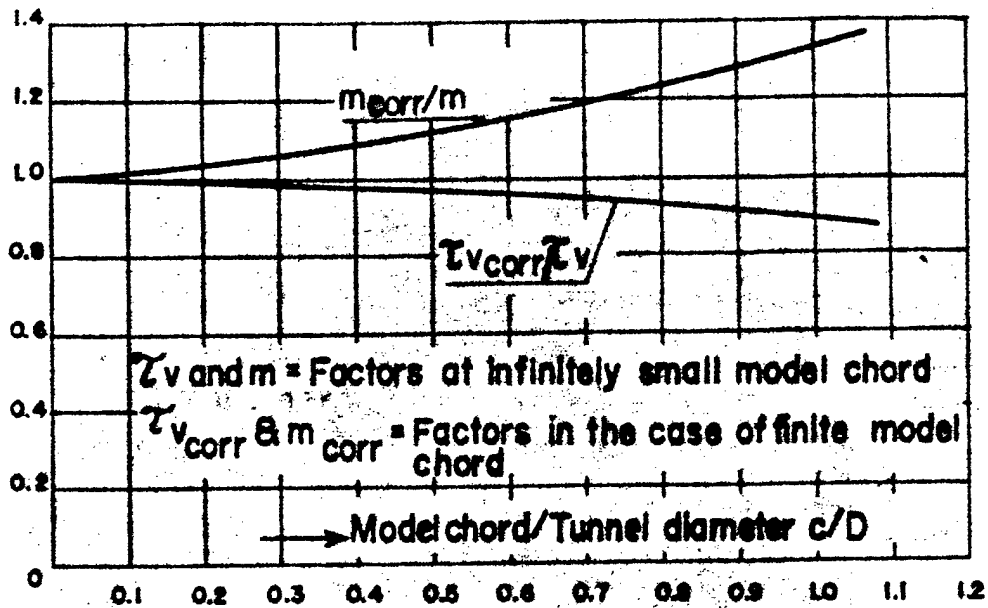

Fig. 6 - Effect of Model Chord and Factors  $\tau_v$  (eq. 3) and  $m$  (eq. 4) for Source Sink Bodies with a fineness Ratio

$$\frac{A}{d c} = \sim 0.75$$

(Rotationally Symmetrical or Wing with Span/Tunnel Diameter  $\rightarrow 0$ )

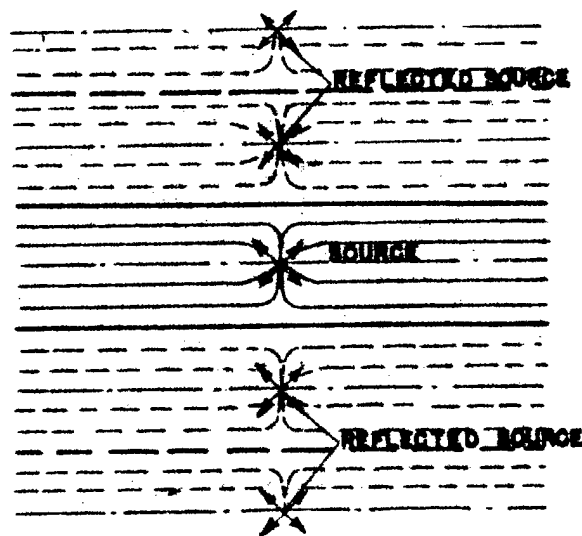
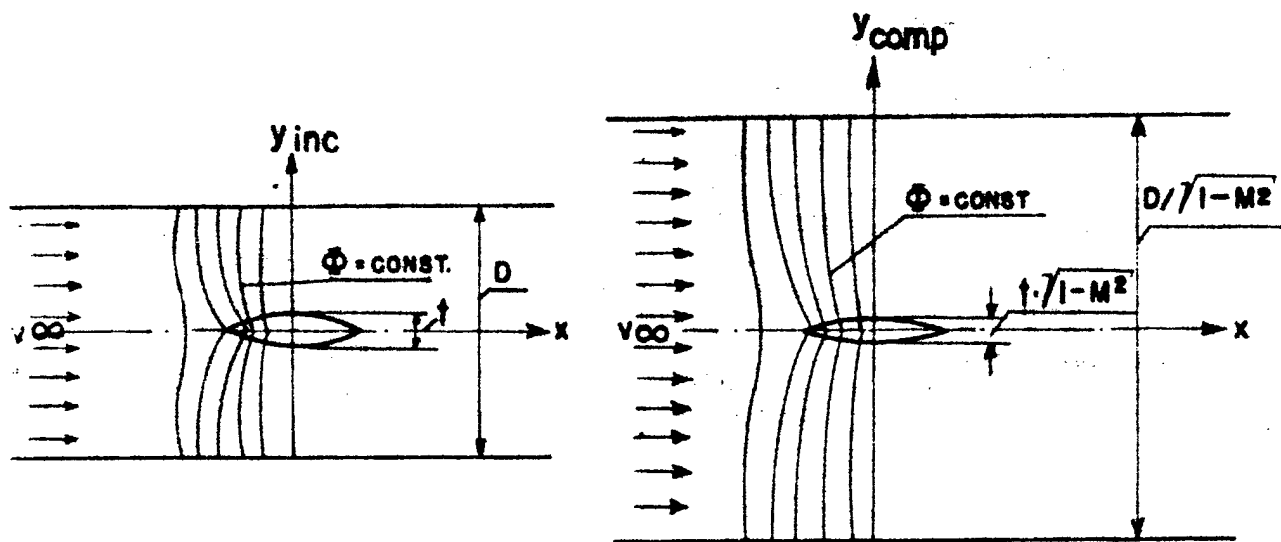

Fig. 7 - Source in Tunnel with Reflected Sources



a) Incompressible medium.

b) Compressible medium Potential lines of a) distorted as per Prandtl.

Fig. 8 - Wing in Closed Tunnel in Incompressible and Compressible Flow in Accordance with the Prandtl Rule

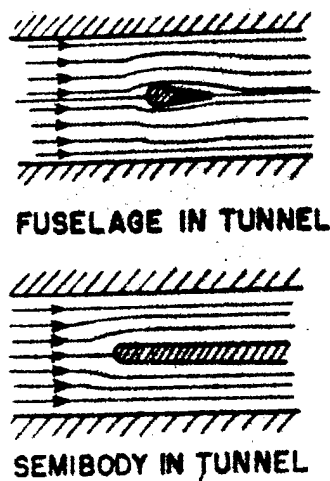

Fig. 8a

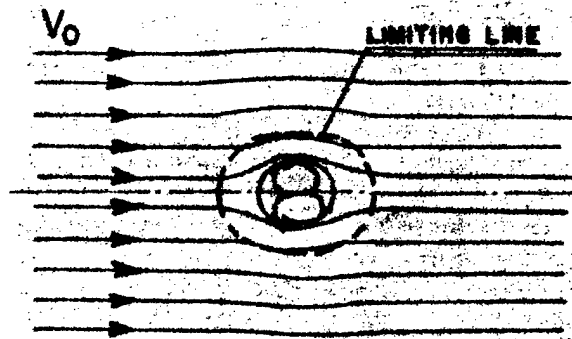

Fig. 9 - Doublet in Parallel Stream

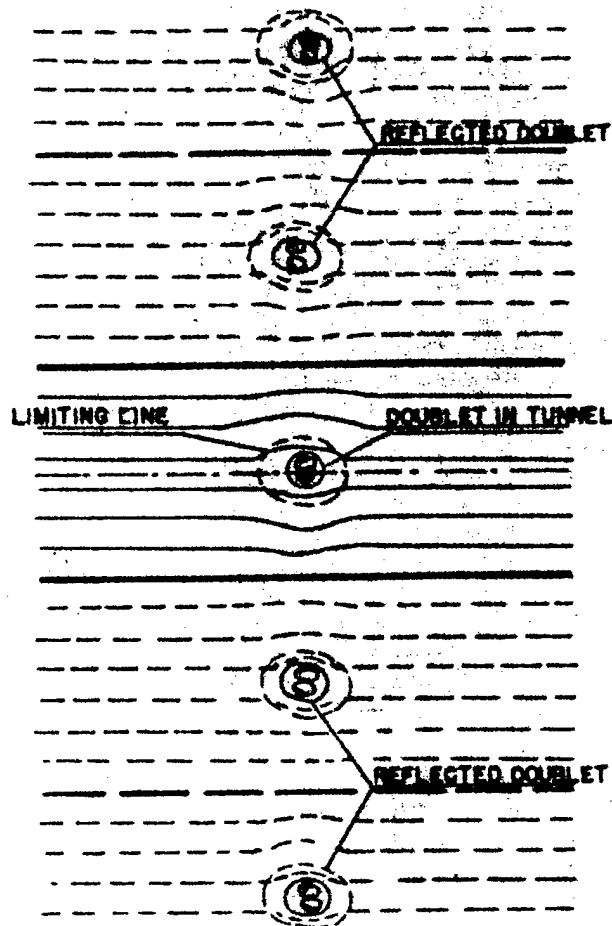

Fig. 10 - Doublet in Tunnel with Limiting Lines for Validity of the Prandtl Rule

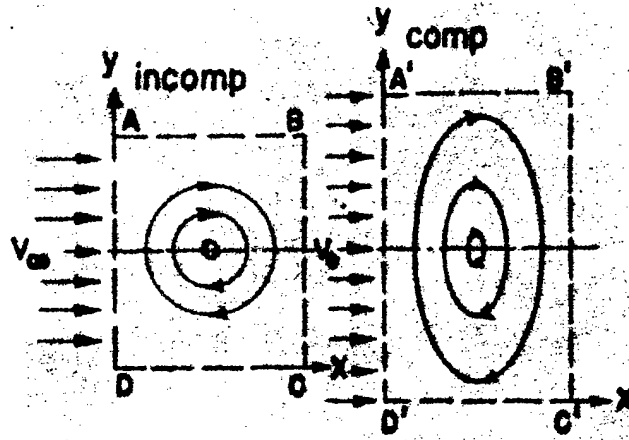

Fig. 11 - Potential Vortex in Parallel Stream

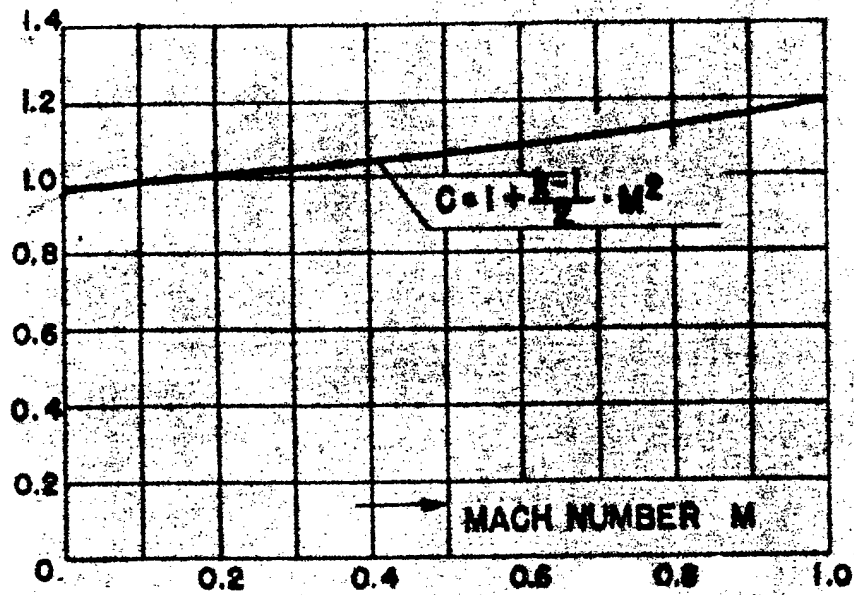

Fig. 12 - Factor C Relative to Mach Number

$$dM/M = C \cdot dv = -1/2 \cdot C \times dp / \frac{\rho}{2} v^2$$

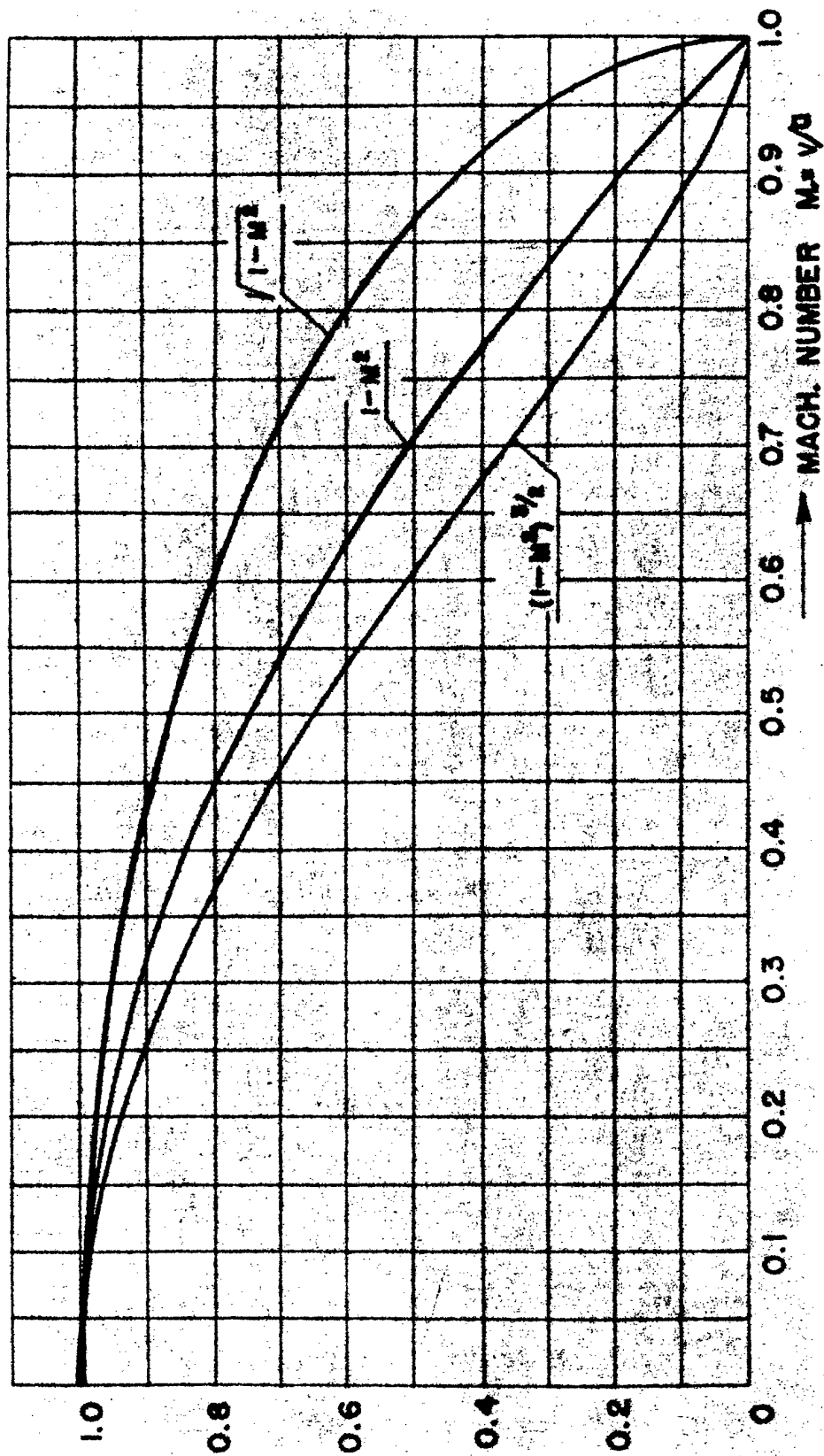

Fig. 13 - Values for  $\sqrt{1-M^2}$ ,  $1-M^2$ , and  $(1-M^2)^{3/2}$  Relative to Mach Number

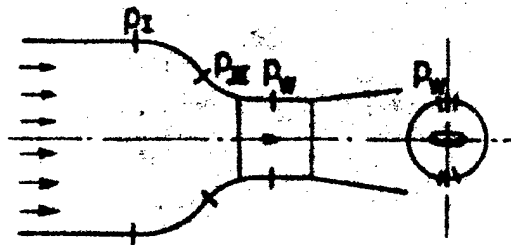

Fig. 14 - Wall Pressures for  
- Determination of  
Dynamic Pressure

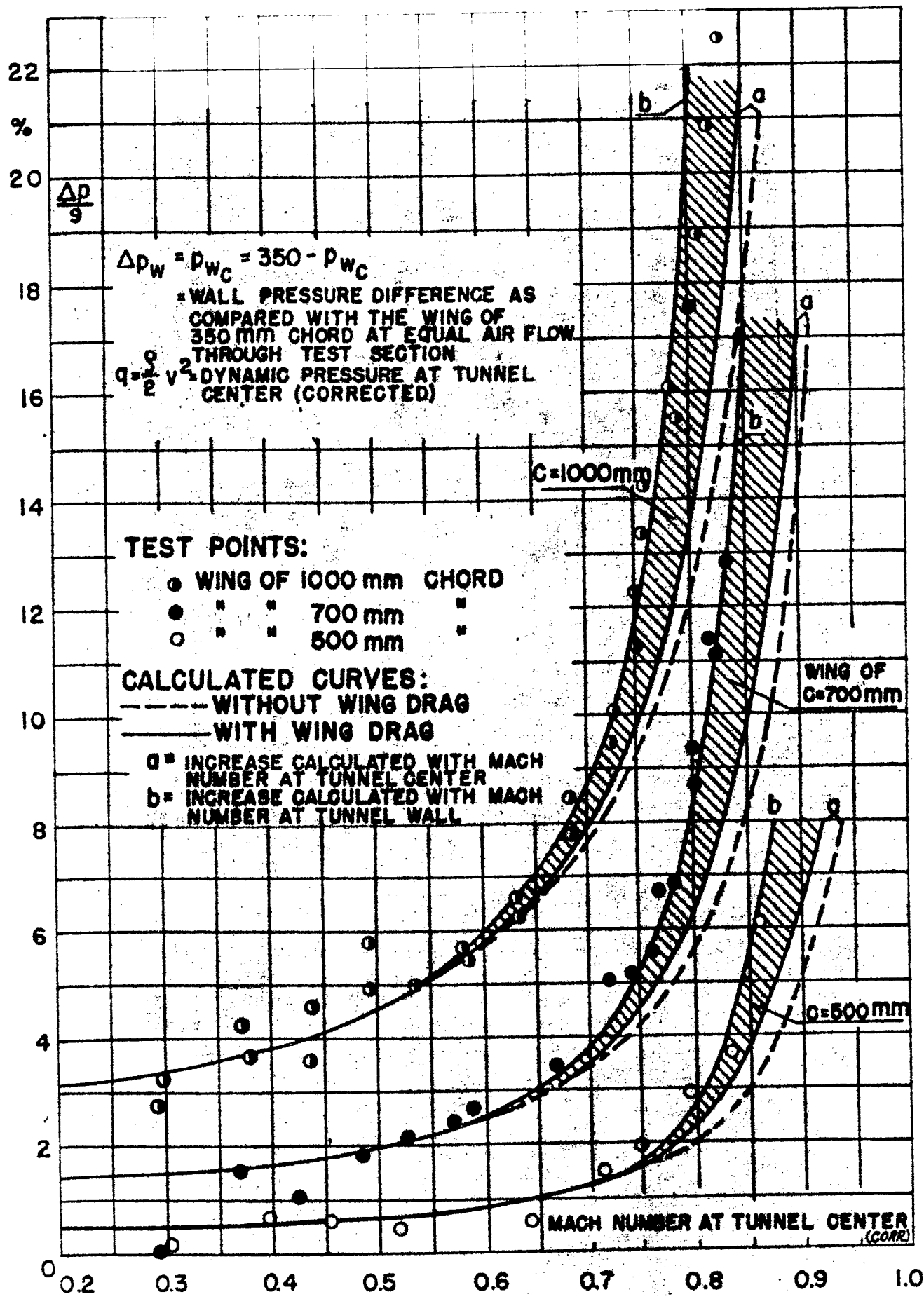

Fig. 15 - Comparison of Measured and Calculated Changes of Wall Pressure Due to Rectangular Wings (NACA 0015-64) of Various Chords

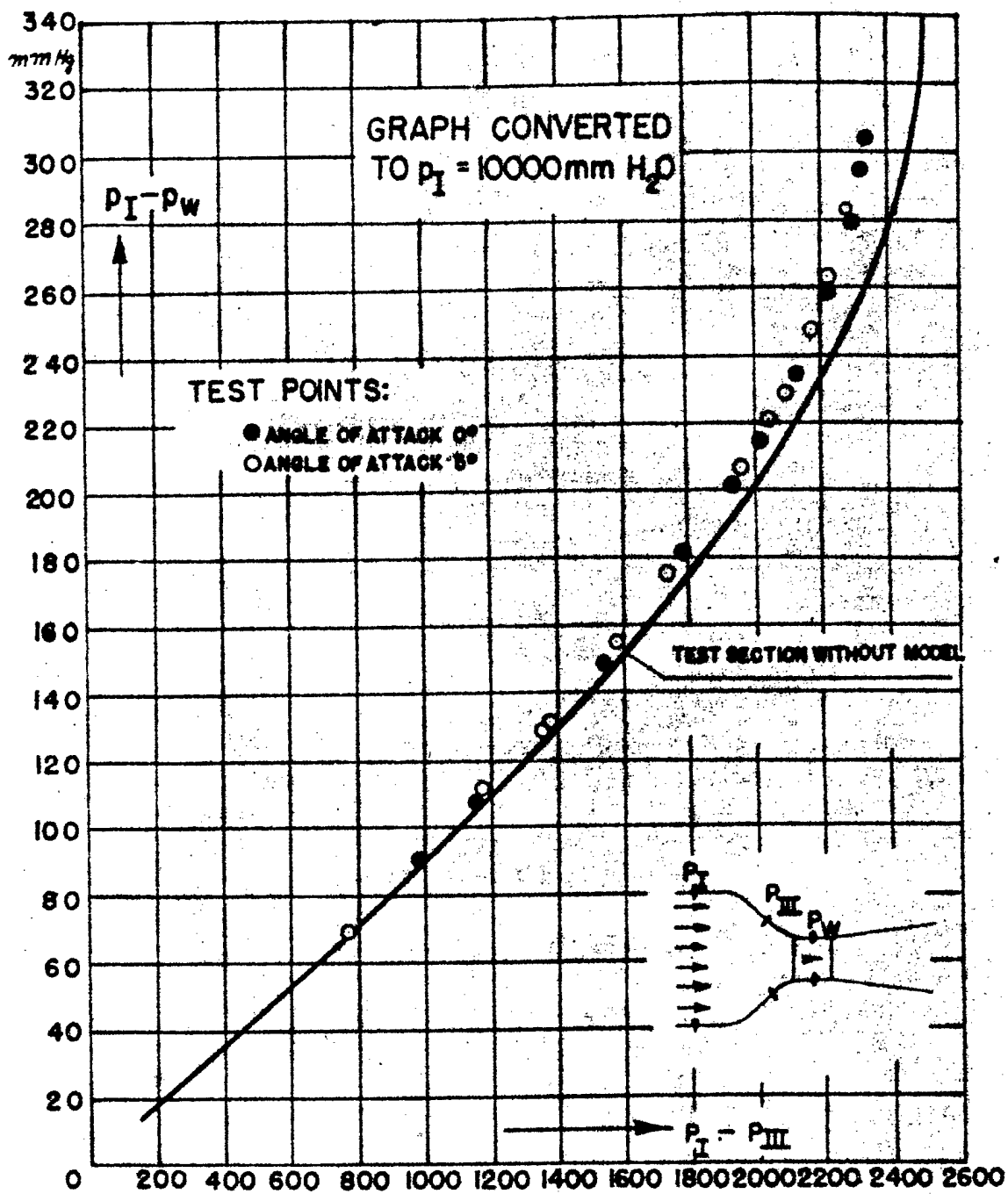

Fig. 16 - Wall Pressures in Test Section at an Angle of Attack of  $0^\circ$  and  $5^\circ$  of a Rectangular Wing (NACA 0015-64) of 500 mm Chord

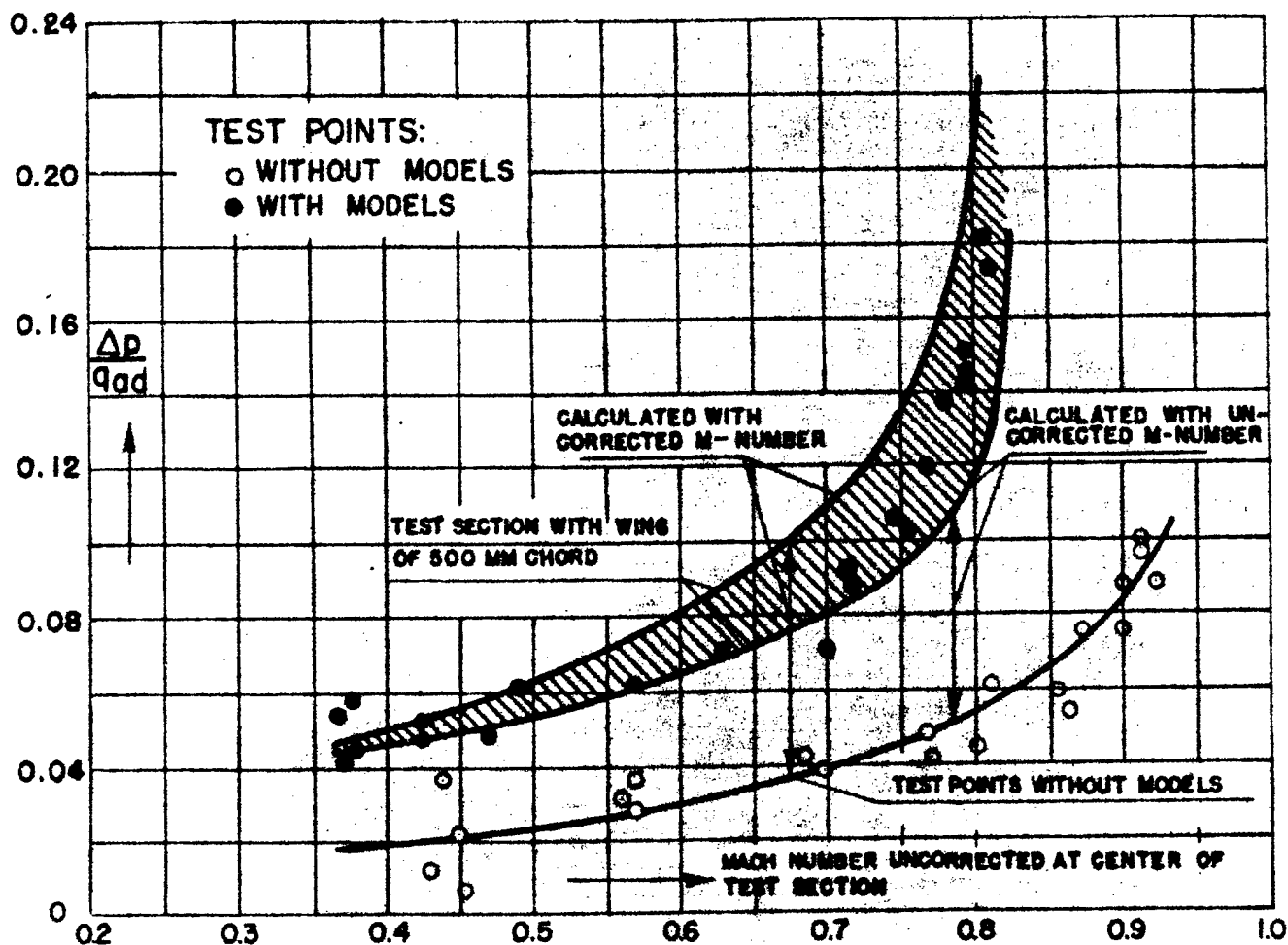

Fig. 17 - Pressure Drop  $p$  in Test Section with and without Model  $\Delta p = p$   
 Beginning - P end = Difference of Wall Pressure Between  
 $q_{ad} = P_0 - P_{t s}$  = Adiabatic Dynamic  
 Pressure at Tunnel Center