

RECORD
COPY

MAIN FILE

OTS

60-41,630

JPRS: 5872
18 October 1960

NEW 12 - CHANNEL EQUIPMENT TYPE V-12-2 FOR
HIGH-FREQUENCY TELEPHONY BY AERIAL
COMMUNICATION LINES

By L. Y. Iontov, S. M. Kovalev, G. N.
Stepanov and N. E. Baskakov

- USSR -

PRICES SUBJECT TO CHANGE

DISTRIBUTION STATEMENT A
Approved for Public Release
Distribution Unlimited

REPRODUCED BY
**NATIONAL TECHNICAL
INFORMATION SERVICE**
U. S. DEPARTMENT OF COMMERCE
SPRINGFIELD, VA. 22161

Distributed by:

OFFICE OF TECHNICAL SERVICES
U. S. DEPARTMENT OF COMMERCE
WASHINGTON 25. D. C.

Reproduced From
Best Available Copy

20000504 106

U. S. JOINT PUBLICATIONS RESEARCH SERVICE
205 EAST 42nd STREET, SUITE 300
NEW YORK 17, N. Y.

172

N O T I C E

THIS DOCUMENT HAS BEEN REPRODUCED FROM THE BEST COPY FURNISHED US BY THE SPONSORING AGENCY. ALTHOUGH IT IS RECOGNIZED THAT CERTAIN PORTIONS ARE ILLEGIBLE, IT IS BEING RELEASED IN THE INTEREST OF MAKING AVAILABLE AS MUCH INFORMATION AS POSSIBLE.

NOTE: In order to expedite its issuance, this publication has been printed directly from the translator's typescript, after a minimum of retouching, cropping and make-up.

This translation has been printed on one side only because the available mimeo paper stock was unsuitable for standard two-side impressions.

JPRS: 5872
CSO: 4664-N

NEW 12 - CHANNEL EQUIPMENT TYPE V-12-2 FOR HIGH-FREQUENCY
TELEPHONY BY AERIAL COMMUNICATION LINES

[This is a translation of a handbook by L. Y. Iontov, S. M. Kovalev, G. N. Stepanov and N. E. Baskakov entitled "Novaya 12-Kanal'naya Apparatura VCh Telegorirovaniya po Vozdushnym Liniyam Svyazi Tipa V-12-2", (English version above), Moscow 1959, pages 1-142].

Svyaz'izdat, The State Publishing House for Electrocommunication. New 12 Channel Equipment for HF Telephony By Aerial Communication Lines, Type V-12-2. Editor-in-Chief: L. E. Iontov. Editor: V. E. Petrova. Technical Editor: K. G. Marko. Revisor: S. N. Borkina. Submitted for type-setting on July 8, 1959. Paper format 60 x 92 1/10. T - 11248 circulation: 12,000. 9.0 pech. 1. Zak. izd. 8747. Assigned for Print on Oct. 19, 1959. 7.97 uch - izd. 1. Price: 4 rubles. Svyaz'izdat, Moscow-center, Chistoprudnyy bal'var, 2. Svyaz'izdat Printing House, Moscow-center, 40 Kirov Street. Zak. tip. 395.

TABLE OF CONTENTS

Preface---

Chapter 1. Basic Information of Apparatus Type
V-12-2

- 1.1. Technical Characteristics of Apparatus
- 1.2. Principles of Structural Mounting

Chapter 2. Block-diagrams of Apparatus

- 2.1. Terminal Office
- 2.2. Tandem office
- 2.3. Derived channel equipment

Chapter 3. Individual Equipment

- 3.1. General Information
- 3.2. Block-diagram
- 3.3. Differential System and Limiter (DSO)
- 3.4. Individual frequency converters and channel filters
- 3.5. Low-frequency amplifier and voice-frequency dialing-ringing receiver
- 3.6. Ringer oscillator (GTV)
- 3.7. Joint operation of sending and receiving devices for voice-frequency ringing and pulse dialing
- 3.8. Switching board PVU
- 3.9. Neper meter
- 3.10. Test amplifier

Chapter 4. Group Equipment

- 4.1. General information
- 4.2. Linear amplifier
- 4.3. Filters
- 4.4. Matching devices and devices for transmitting distance supply
- 4.5. Initial slope equalizers
- 4.6. Group frequency converters
- 4.7. Transmission amplifier
- 4.8. Reception amplifier
- 4.9. Group routes equalizers
- 4.10. Terminal station group route filters

Chapter 5. Generator Equipment

- 5.1. General information
- 5.2. Block-diagram
- 5.3. Master oscillator
- 5.4. 4 Kilocycle amplifier and harmonic oscillator
- 5.5. Current amplifiers for group carrier frequencies
- 5.6. Generator equipment filters
- 5.7. 4/5 kilocycle converter

Chapter 6. Tandem Office

- 6.1. General information
- 6.2. Set noiser and non-linear distortions of tandem office
- 6.3. DK-2.8 and BDK-2.8 filters
- 6.4. Group routes equalizers
- 6.5. VK-33 equalizer
- 6.6. Speak-buzz device

Chapter 7. Automatic Level Regulation (ARU) Devices

- 7.1. General information
- 7.2. Control channel receiver
- 7.3. ARU control panel
- 7.4. Adjusting artificial lines
- 7.5. 50 cycle generator

Chapter 8. Apparatus for Separating Channels

- 8.1. General information
- 8.2. Group amplifiers
- 8.3. Group routes filters

Chapter 9. Some Features of Equipment Operation

PREFACE

In the "Control figures of USSR national economic development for 1959 - 1965", approved by the 21st Congress of CPUS, a further growth of the inter-city communication network is foreseen with such an estimate that at the end of the seven-year plan network expansion will double. This problem is solved mainly at the expense of cable main construction and the creation of multi-channel multiplexing systems of symmetrical and non-symmetrical cable lines.

However, the number of aerial copper and bimetallic circuits in our country still continues to be considerable, and therefore, the different high-frequency telephony apparatus types require for them constant improving and bringing into accord with the achieved development of distance communication technique.

At the present time, 12 - channel type V-12 high-frequency telephony system equipment is installed on the principal aerial mains of the country. Operation tests revealed equipment shortcomings and aided in the determination of a number of requirements for the equipment, and also to define more exactly the requirements formulated

earlier.

Some of the shortcomings are: weak stability of equipment parameters, understated value of the nonlinear loss in linear amplifiers, considerable overall sizes of all apparatus types, impossibility of separating channels at the tandem points, raised level of noises in the channels; principle, which is of little use for medium and small LAZ of apparatus distribution on the racks and so on.

In 1957 industry finished modernization of the 12 - channel system of high-frequency telephony by aerial communication lines - V-12-2, which since 1958 is mass production produced. At present the modernization of the 3 - channel system (V-3-2) is being completed.

The creation of the stated types of apparatus will further the technical arament of inter-city communication in correspondence with the resolutions of 21st Congress of KPSS, which showed the necessity of implanting modern accomplishments of science and engineering into all the branches of national economy in USSR.

The following were considered to be the main problems in modernization of V-12 equipment: keeping constant the initial system data (linear spectrum, transmission level, transmission distance and length of transducer sections); producing the possibility of operation on circuits parallel with V-12 systems; raising the stability and dependability of operation for all units and for apparatuses as a whole; improving electrical characteristics of apparatuses and raising the channel communication quality; considerable decreasing of overall sizes; providing and lowering the cost of operation; providing the organizational possibility of modern production methods.

The present write-up was given by L.E. Iontov, S.M. Kovalev, G.N. Stepanov, and N.E. Baskakov.

All remarks on the given presentation should be addressed to: Moscow-center, Chistoprudnyy bul'var, 2, Svyaz'izdat.

Technical administration of The Ministry of Communication, USSR.

Chapter 1. BASIC INFORMATION OF APPARATUS TYPE V-12-2

1.1. Technical characteristics of apparatus

The 12-channel apparatus system V-12-2, and also the apparatus V-12 which preceded it, is intended for multiplexing aerial circuits made from non-ferrous metal with wire diameter 3.5 or 4.0 mm.

System V-12-2 is a two-wire two-band system. Its principal technical characteristics are given in Table 1.1.

Table 1.1. Technical characteristics of the system V-12-2

Characteristic	Value
Number of channels	12
Common linear frequency spectrum (kc)	
a) bottom channel set (direction B-A)	36-84
b) top channel set (direction A-B)	92-143
Number of versions of linear frequency spectrum	4
Control currents frequencies in the line (kc):	
a) direction B-A	40 and 80
b) direction A-B	92 and 143
Transmission level for each channel at the output of terminal and tandem offices (neper)	+ 2.0
Maximum amplification of tandem office at end frequencies (neper):	
a) bottom channel set	2.0 and 5.7
b) top channel set	5.7 and 8.0
Variation limits of frequency characteristic slope of tandem and terminal offices (neper):	
a) direction B-A	0.5-3.7
b) direction A-B	0.3-2.3
Level of control currents at the output of terminal and tandem offices (neper) Non-linearity loss of the tandem office at output level + 2.0 nepers:	
a) at second harmonic	8.5
b) at third harmonic	10.0
Nominal value of input resistance of tandem and terminal offices (Ω)	550-600
Reflection coefficient from the line, %	10
Limits of flat regulation of amplification for tandem and terminal offices (neper)	5.0

Characteristic	Value
Effectively transmitted channel frequency band (c)	300-3400
Values of measuring levels in the 4-wire part of the channel (nep):	
a) at the beginning of transmitting route	-1.5
b) at the end of receiving route	+0.5
Net loss of channels at frequency 800 c (neper)	0.8
Coefficient of nonlinear distortions of the channels (with $f=420$ c), %	1.5
Frequency of the voice-frequency ringing-dialing (c)	2100
Voltage of power supplies (v):	
a) plate battery	206 + 3%
b) heater battery	21.2 + 3%
Time stability of net loss (neper)	0.15
Set noise level of terminal office in the spectrum of one channel, measured at a point with level + 0.5 nepers, 4-wire output (mv psoph.)	0.6
Set noise level of tandem office in the spectrum of one channel, measured at a point with level + 2 (nep)	-5.8
Total distance of telephone operation (km)	10,000
Length of transducing section (km)	2,000
Number of transducing sections	5

In addition to the information given in the table, it is necessary to note, that four possible alternates of the linear spectrum of apparatus V-12-2, used with the operation of several systems on parallel circuits to decrease the transitions between them, are formed by inverting the channel frequency bands in the lower frequency group and by inverting and displacing on the operation band spectrum in the upper frequency group (Fig. 1.1.)

The terminal office A transmits the upper frequency group into the line and receives the lower, and office B transmits the lower frequency group into the line and receives the upper. It is obvious that offices A and B have a completely coincident individual equipment and differ only in the group part. Every terminal office is supplied by an apparatus, which provides the reception of group

carrier currents only for one variant of the linear frequency spectrum.

Fig. 1.1. Versions of the linear frequency spectrum for equipment V-12-2.

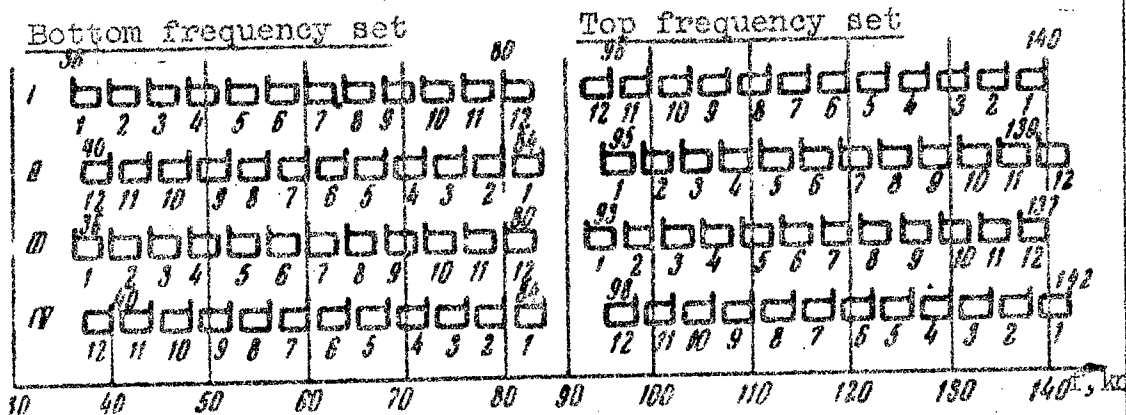

The values of pilot frequencies in the line remain constant in all alternates of the linear spectrum. The control currents with frequencies 80 and 92 kc are used for the flat regulation of the level and with frequencies 40 and 143 kc for the slope regulation.

All carrier and some control currents are produced as a result of their harmonic generation. The master oscillator with quartz stabilization produces oscillations with frequency 4 kc and with stability $2 \cdot 10^{-6}$, as a consequence of which the signal frequency variation in the range of one transducer section is not over 1 c when the signal passes the channel.

Electromechanical system ARU is used in the equipment. To decrease communication idle periods with harsh meteorological conditions, when the automatic regulation range of amplification is already used up, in the apparatus is provided a possibility of sudden flat increase of amplification in comparison with the information given in Table 1.1, by 0.5 neper for lower frequency group and by 0.8 neper for upper frequency group. This switching is made manually.

In the separate equipment of the terminal offices channels the speaking currents of all channels are transferred into the frequency 60-108 kc spectrum, which is taken as the initial one for 12-channel group in all home multichannel systems.

Transition from spectrum 60-108 kc to linear frequency spectrum (Fig. 1.1) is made by two steps of the group conversion, whereupon the second conversion-step in the transmission route and the first in the reception route are realized with the aid of carrier frequency, the value of which depends on the selected spectrum alternate.

In the reception route of each channel, the possibility of net loss characteristic compensation is provided with the condition that its values at different frequencies would not go out of range shown in Fig. 1.2.

Fig. 1.2. Permissible deviation range of the channel net loss, γ_{net} .

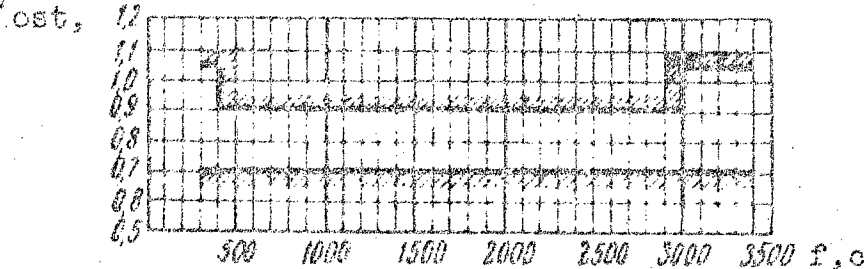

The derived channel equipment was developed simultaneously with system V-12-2. This equipment permits to derive four telephone channels at any tandem office, if the system operates in the first linear spectrum alternate.

The derivation is made with the restoration of the used frequency band, i.e., any tandem point can get connection through four channels in the direction of each terminal office. The derived channels hold frequency band 68-84 kc (lower group) and 92-108 kc (upper group) in the linear frequency spectrum; according to the established numeration these are the channels 9-12.

Connection of the derived channel equipment practically does not change the through channel characteristics, and the derivation of channels by their data fully meets the norms, established for main line channels.

Equipment V-12-2 can operate on one circuit together with other systems in which spectrum is used up to 28.5 kc. Telephone channels formed by this equipment permit a second multiplexing, i.e., a voice frequency telegraphy and phototelegraphy, and with the incorporation of two or three telephone channels permit the transmission of a high-quality broadcasting program.

In relation to linear spectra, transmission levels and control current frequencies coincide in systems V-12-2 and V-12, and it turns out that not only the operation of given systems on parallel circuits are possible, but also the equipping of one main line tie with miscellaneous equipment. However, if for one circuit a different outfit at the tandem offices (PV-12 and PV-12-2) and a different group outfit at the terminal offices can be established in principle, then the individual outfit on both terminal offices should be the same. This requirement is determined by the difference in the voice-frequency ringing systems, taken for equipment V-12-2 and V-12.

The auxiliary repeater office (VUS-12), switched on during unfavorable weather conditions, can also operate on a circuit, equipped by apparatus V-12-2. A distance feeding device is introduced into the outfitting makeup of terminal and tandem offices, to provide for the operation of VUS.

The current consumption by different offices, entering into the V-12-2 system, is shown in Table 1.2.

<u>Station</u>	Filament current, amp. $U_n = 21.2 \text{ v.}$	Filament current, amp. $U_a = 206 \text{ v.}$
Terminal office:		
a) Group and generator equipment	10.0	0.61
b) Separate equipment	3.1	0.32
Tandem office	5.5	0.52
Derived channel equipment	4.6	0.45

Table 1.2. Permissible deviation range of the channel net loss.

With the operation of signal circuits the current consumption from 21.2 volt battery is increased by not more than 0.5 amp.

Two types of electronic tubes are used in the equipment: 6Zh1P-E and 6P3S-E (besides the 4 kc generator, where a 10Zh1L tube is used. Both tubes have an increased life span (5000 hours). Principle parameters of these tubes are given in Table 1.3.

Parameter	6Zh1P-E	6P3S-E
Heater voltage, v	6.3	6.3
Heater current, ma	170	900
Plate voltage (max), v	120	250
Plate current ma	7.5	70
Characteristic transconductance, ma/v	5.1	6
Output power (max), w	—	5.4
Bias voltage on control grid, v	—	-14
Screen grid voltage (max), v	120	250

Table 1.3. Parameters of electron tubes GZh1P-E and GP3S-E.

Total number of tubes on the rack frames, not counting the spare tubes, are given in Table 1.4.

Direct heating thermistors TP-2/0.5, TP-G/2 and TP-2/2 are used in the equipment.

Rack	Number of tubes	
	6Zh1P-E	6P3S-E
SIO-12	36	-
SGO	37	6
PS	19	7

Table 1.4. Number of tubes on racks.

1.2. Principles of structural mounting.

Structural equipment arrangement in apparatus V-12 provides grouping of similar type units for several systems in the capacity of one rack frame, e.g., the frame of SDS for 9 systems, STV for 2 systems, SChK for 5 systems and so on. In distinction from apparatus V-12, in apparatus V-122 the outfitting is completed by a principle of concentrating different units, relating to one system, on the minimum possible rack number.

The units of terminal and tandem outfits, following from their mutual attraction, are arranged on different rack forms with the consideration of convenience of operation.

Terminal equipment of apparatus V-12-2 is arranged on two racks: SIO (individual outfitting rack) and SGO (group outfitting rack) - Fig. 1.3.

Fig. 1.3. General view of the terminal office V-12-2.

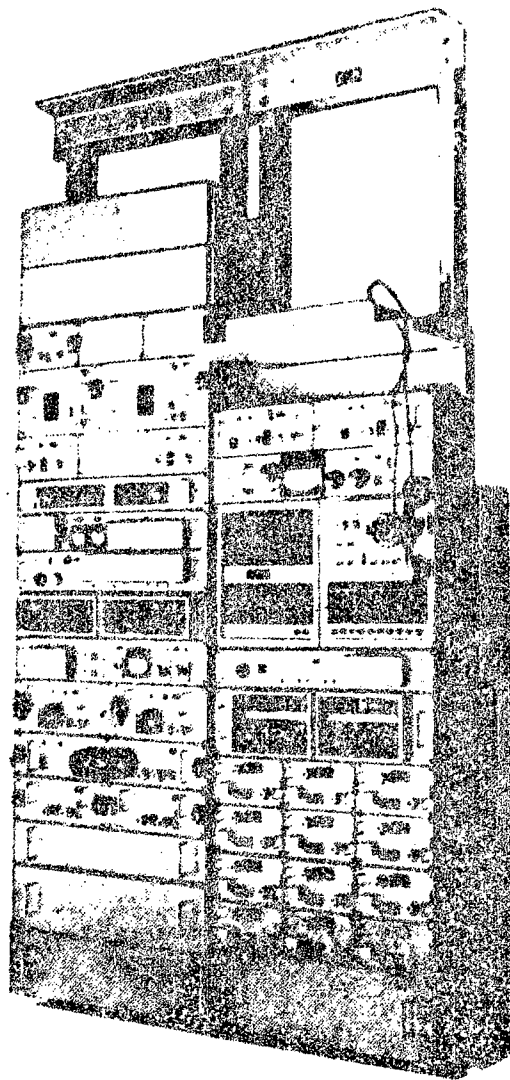

SIO is manufactured in two alternates: with a set of units for one system (12 channels)- SIO-12 and with a set of units for two systems (24 channels)- SIO-24. The rack of SIO-24 can be used for common operation with two racks of SIO (in this case the terminal outfit V-12-2 for two systems is arranged on three racks), and also for the 24-channel system of high-frequency telephony by cable lines (K-24 and K-24-2).

The SGO rack of office A or B is outfitted so that it is applicable to each spectrum alternate for one system, besides this the complete names of racks are: SGO-A-- spectrum I, SGO-B-- spectrum I, SGO-A--spectrum II, SGOB -- spectrum II and so on. Thus, altogether there are eight alternates to outfit the SGO racks.

The generator equipment, arranged on rack SGO, can feed two systems. In relation with this the manufacture of SGO racks without generator equipment is also provided.

All equipment of the tandem office V-12-2 for one system is placed on one rack - PS.

Derived channel equipment is also placed on one rack - SVK. On Fig. 1.4 the general view of the tandem office is given and also of the rack SVK which is operating together with it.

Matching device panels (two panels on PS and one on SGO) are included in the rack SGO and PS sets. The matching device panels depending on the wave impedance of the cable, which is connected to the apparatus (cable with styrene-flexion insulation or coil-loaded cable), have different construction. A device, in a separate box, is included in the apparatus to test the electron tubes (PIEL).

Besides the fundamental equipment, flexible cords and bows, necessary for switching and measurements, are included in the rack sets, and also spare parts, technical documentation albums and the regulating instrument.

A unit principle of apparatus structure is used in system V-12-2, i.e. such, with which different units, which are electrically connected by interunit wiring and mechanically connected into a single supporting structure.

By a unit is understood a structurally molded and electrically completed unit, e.g. linear amplifier, 4 kc oscillator, channel filter and others. The unit can be separately tuned and checked. Specific requirements, as a rule, are presented to its parameters. The unit principle of construction makes it possible to create compact units, in respect to structure, which can be easily replaced when they are out of order.

Largest part of units in apparatus V-12-2 is of the cut-in type, i.e. they are joined with the common panel mounting or rack by a special contact joints -- jack and

knife pairs (blocks).

Fig. 1.4. General view of tandem office PS and derived channel equipment bay SVK.

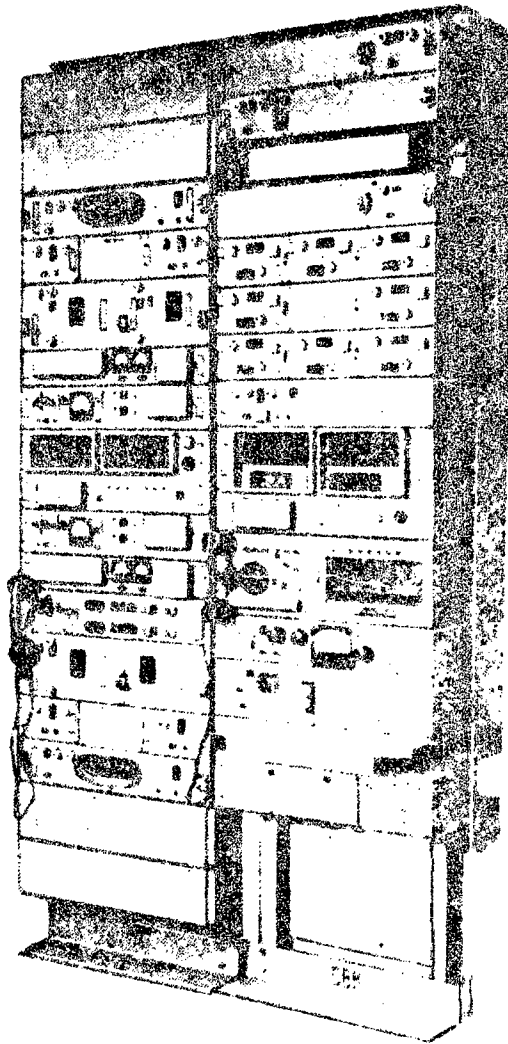

Units, that are withdrawn from the rack but which are in an operating condition, are checked and examined with the aid of flexible cords, which are applied to the office.

Terminal equipment units, and also the tandem equipment units are placed on separate panels (plates) in each

rack. About 60% of all panels contain cut-in units, which can take either the whole panel width or only part of it. All units with electron tubes (amplifiers, generator devices, control channel receivers, etc.) and units containing the control elements (panels with relays, switches, etc.) are made in the form of cut-in units.

Filters, equalizers and some other units, the production of which in the form of cut-in structures were practically unnecessary, are made in form of panels which are permanently fixed to the rack. These panels are connected to the principal cable of the rack by soldering, which is made on the distributing block or directly on the unit elements.

Small part of panels has a combined structure, i.e. some of its units are cut in and others are directly fixed to the rack. An example of such structure is the panel of the group transmission (reception) converter of the SGO rack, where the amplifier is made in the form of cut-in unit and the filters and converters are not dismountable.

All cut-in units, besides the contact joints, are provided with studs, which fix their position in the panel. Besides that, in the latter there are directing slides, which limit the side displacement of unit when it is inserted.

The 16 and 30-contact blocks, fastened by clamps on the sides or back of the unit, are used as the contact joints.

In most cases the high-frequency circuits are led up to the cut-in unit through a connection which consists of shielded jacks and bows. In addition to this, two jacks are fastened on the front panel of the cut-in unit, and the other two jacks on the unit cover. Some mobility of one of the mentioned jack pairs, permits them to be connected by bows.

All cut-in units, for the convenience of their arrangement on the rack (and their withdrawal), are provided by handles. General view of the cut-in panel-unit of the linear amplifier, which is included in the equipment set of SGO and FS racks, is shown on Fig. 1.5.

The width of all panels is 646 mm, and the depth is 160 mm (without the protruding handles). In height the

panel dimensions, as a rule, are multiples of 30 mm (120, 150, 180 mm, etc.), whereupon the most frequently encountered panel dimension is 120 mm. Panels with units are placed and fastened on a standard frame, made from channel bar and corner steel and having a height of 2500 mm and a width of 648 mm. The panel arrangement is two-sided.

Those panels and units, which during operation are subject to control and regulation (RIL panels, linear amplifiers and others), are placed on the front side of the racks. In the central part of the racks the protector panel is placed on the front side. Panels are provided with a protecting cover on hinges made from an organic glass, for ease of examination and replacement of fuses.

Fig. 1.5. General view of the cut-in panel unit of linear amplifier IUs.

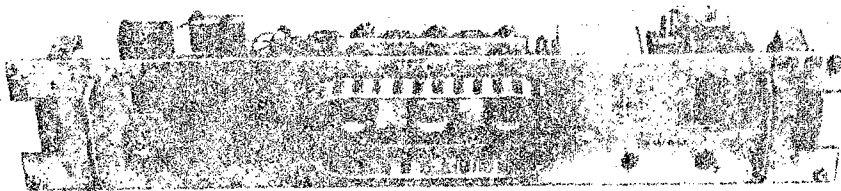

On the back side of the panels, the feeding buses are placed at the top. The blue bus is connected to the heater current source (-21.2v), white and red are connected to the grounded poles of the feeding batteries and the rack frame.

Rack SIO-12 weighs 370 kg, SIO-24 weighs 430 kg, SGO -- 360 kg, PS -- 390 kg and SEK -- 370 kg.

Structural mounting of the apparatus was determined, to a certain extent, by the applied types of semi-manufactured products and switching components, which are distinguished by small overall sizes, increased dependability and the use of new materials. One of them was specially developed during the project period of V-12-2 system; others were borrowed from the number of new elements, made in the adjacent branches of radioelectronic industry.

Fig. 1.6. Miniature frame "catwhisker" and an old type "catwhisker" frame.

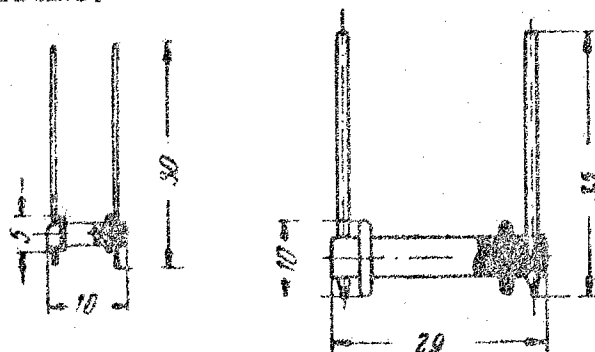

The principal information on some applied semi-manufactured products is given below.

Type MLT wireless resistors have powers of 0.5, 1.0 and 2.0 w, and the miniature ULF — 0.12 w. Wire resistors are made on ceramic and plastic frames. The miniature plastic frame "catwhisker", shown on Fig. 1.6, is extensively used. The variable wire-type resistance on the ceramic frame is illustrated on Fig. 1.7. This is regulated by the micrometer screw.

Fig. 1.7. Variable wire resistance.

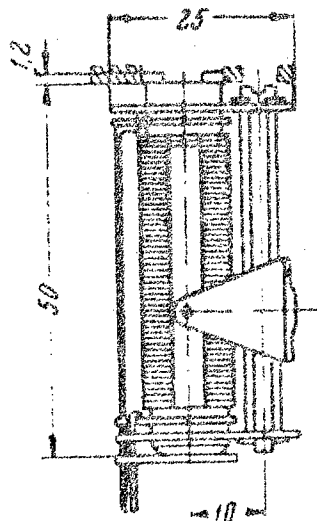

The capacitors installed in the apparatus can be divided into two types; one mass type, widely applied

but the radio electronic industry, such as KSO, SGM, KVGI, MGVP, MVGO, KTK and KCK, two, especially accurate and stable types SSG and SGMZ (micron, silver) on the given capacitors with tolerance $\pm 0.3\%$ (Fig. 1.8).

Fig. 1.8. General view of capacitors SGMZ-A (from 50 to 400 μf) and SGMZ-B (from 400 to 10,000 μf).

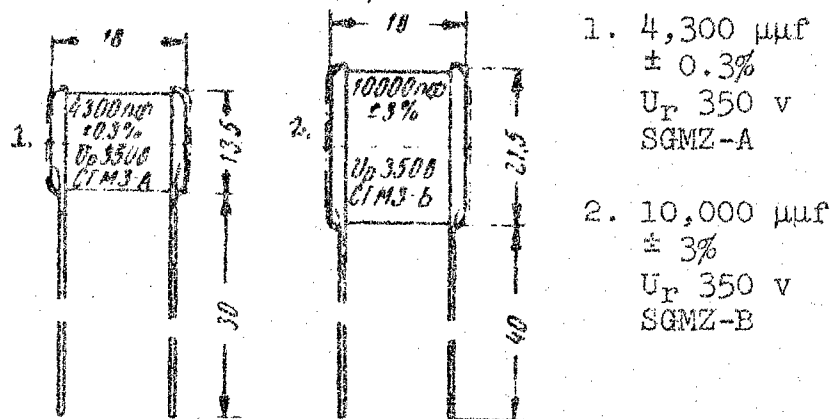

Styling flexion capacitors KEG are inserted in filters DK-2.8.

Ferrocort ($\mu = 1,000$ or $\mu = 2,000$) or plates from term alloy or transformers steel are used as the course for transformers in the apparatus.

The overall dimensions of ferrocort core (type OSh-7) and of the coil body are given in Fig. 1.9.

Fig. 1.9. Ferrocort transformer core type OSh-7. Frame of coil OSh-7.

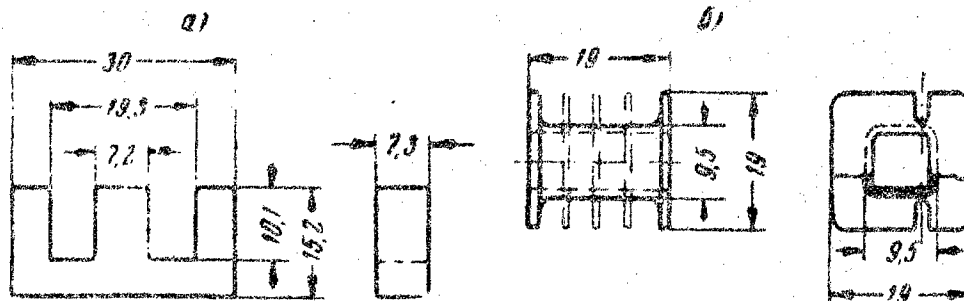

Ferrocart is used for the form for more than 60% of all apparatus transformers.

From the other semi-manufactured products, extensively used in the apparatus, should be mentioned: germanium diodes D2B, D2G and DG-TS24; appears a crystal resonators, made from natural quartz and also from artificially grown crystals; relays RPN, RPB-5, RPNV and specially developed magnito electric relay RNE-2.

Fig. 1.10. 16 and 30 contact blocks.

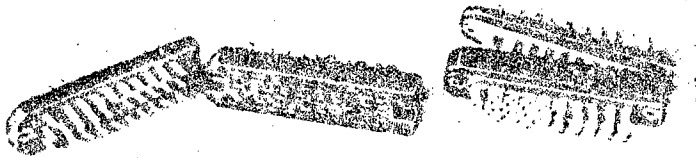

Fig. 1.11. Little bows.

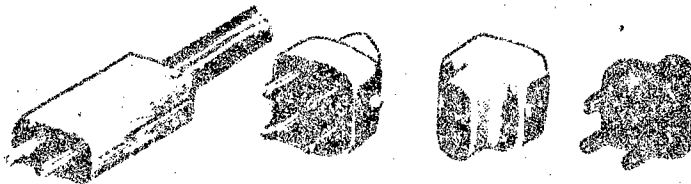
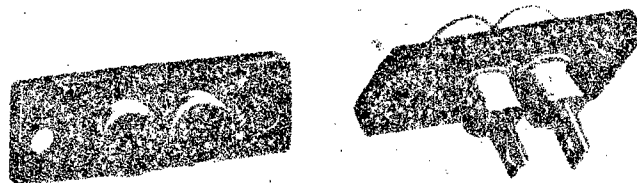

Fig. 1.12. Socket strip.



The apparatus has a large number of switching elements, such as the above-mentioned 16 and 30 contact blocks (Fig. 1.10), bows (Fig. 1.11), strips shielded sockets (Fig. 1.12), terminal lock, strips with contact lobes, wiring blocks and so on.

Chapter 2. Block diagrams of the apparatus.*

(* Block diagrams of the principle forms of apparatus V-12-2 equipment (terminal, tandem and derived channel) examined below, contain only the most important units, and also the level values and input impedances at some route points.)

2.1. Terminal office.

The block diagram of the terminal office for system V-12-2 is given in Fig. 2.1.

The transmission route begins with the unit DSO, the differential system with limiter. In distinction from the apparatus type V-12, both devices are combined here into one unit. The first divides the transmission and reception route, and the second limits the speech signal level, and through this prevents overload of the group devices. After the DSO unit the dividing sockets of four-wire route are placed which provide the possibility of channel control and measurement.

Individual conversion takes place in the modulator M, to which the carrier frequency from generator equipment supplied (its value depends on the channel number 108 kc for the first channel; 104 kc for the second channel and so on up to 64 kc for the twelfth channel). The interval between the adjacent individual carrier frequencies = 4 kc.

At the convertor output, the channel band filter PF is connected, which contains pairs of crystal resonators. This filter suppresses upper side band and other conversion products, and also partly the remainder of the carrier frequency current. Output terminals of all 12 channel filters are connected in parallel.

A compensating circuit (Komp. kont) is connected with the same terminals in order to compensate for the filter loss frequency characteristic when they are operating in parallel.

Further, the converted speaking currents of all channels pass through the group route, the first element of which is the band elimination filter ZF.

FIG. 2.1. Block diagram of terminal office V-12-2.

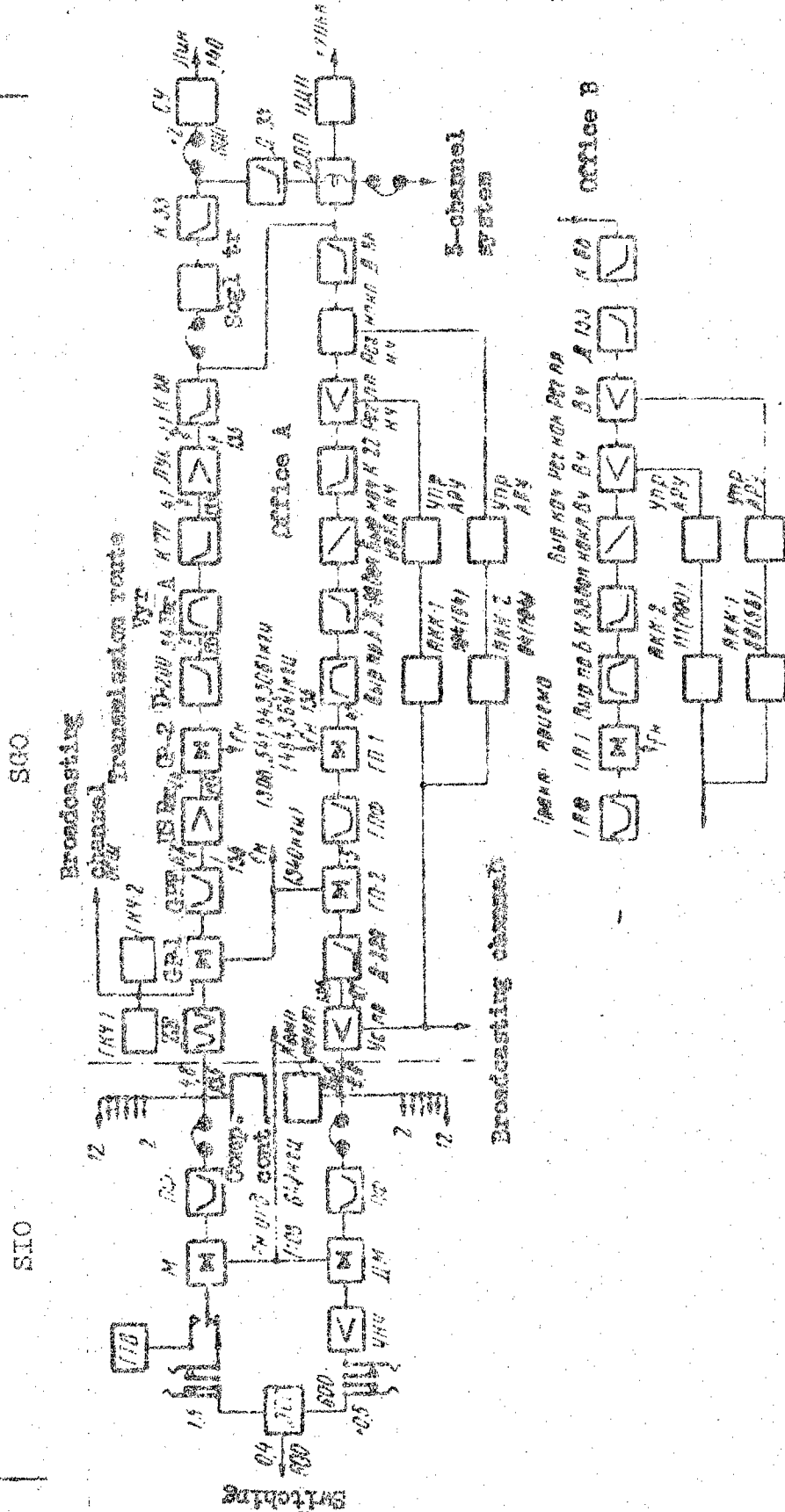

If the given office transmits the upper frequency group 92-143 kc (office A), then the band elimination filter is designed to suppress the remainders of carrier currents from all channels, and if the office transmits the lower frequency group 36-84 kc (office B), then only the remainders of currents for 64 and 104 kc are suppressed.

In the first case filter ZF, having 12 attenuation peaks, prevents the transit of carrier frequency current remainders into the system channels, which operates on a parallel circuit with displaced spectrum. Thereby the noise level is lowered in these channels and additional interference is eliminated. Since the lower frequency group with all spectrum alternates does not have a displacement, then with its transmission there is no danger of carrier current remainders getting into channels of other systems; therefore in the second case it is necessary to eliminate from the 60-108 kc spectrum only those frequencies, which coincide with the frequencies of the control currents. In correspondence with this filter ZF has two attenuation peaks and eliminates the superposition of interference on the control signal, as a result of which the operation stability of level regulation system is increased.

The first group convertor GP-1, connected after the filter ZF, with the aid of current of group carrier frequency 340 kc "carries over" the operating frequency band 60-108 kc to another spectrum region 400-448 kc. Along with currents from individual equipment, also the control frequency currents from the corresponding generator devices GKCH-1 and GKCH-2 are converted in the GP-1 convertor. For office A the current frequencies produced by GKCH-1 and GKCH-2 are correspondingly equal to 60(58) and 111 (109) kc; for office B- 64 kc and 104 kc.

The band filter GPF, which is placed immediately after the GP-1 convertor, separates the upper frequency side band 400-448 kc, which is necessary for further conversions.

From all the values which the signal has in the tandem office routes, it has the lowest level (6.2 nepers) at the output of GPF filter. Therefore after GPF filter the amplifier US. PER. displaced in the transmission

route, after which a second group convertor GP-2 is connected. The carrier frequency of this convertor depends on which alternate of the linear spectrum is required to be received (Fig. 1.1).

Filter D-200 limits the lower frequency side-band, which is subject to transmission into the line. The group route elements and first of all filters introduced non-uniformity into its amplitude frequency characteristic, and for the elimination of this phenomenon it is necessary to connect an equalizer VYR. PER. A (into the route (in office B-VYR. PER. B). After the equalizer the filter K-77 is placed, which limits the transmitted band from the low frequency side and by this prevents the overload of the following element, the linear amplifier LUS, by the unused conversion products. This filter is included only into the transmission route of office A. Office B does not have this filter and after the equalizer the amplifier LUS is placed immediately.

Linear amplifier raises the level in each channel to the value + 2.1 neper.

From the amplifier LUS output the linear spectrum currents enter into the upper frequency gliding filter K-88 (in office B-D-88) and then through the matching transformer into the linear filter K-33, which serves to separate the 12-channel system current from the system which occupies the lower frequency spectrum.

The matching device SU, intended for the matching of input impedance of the cable entrance and the office, is a transmission route element and the first reception route element of the terminal office.

The reception route begins with the same elements, with which the transmission route ends: SU and K-33. Further in station A the filter D-88 is placed, which separates the reception frequency-band from the transmission frequency-band. After this filter follow two equipment units called REG. NAKL. NCH and REG. PF. NCH and are part of the automatic level regulation device. REG. PF. NCH with a change of line attenuation changes the amplification introduced by it equally for all frequencies (flat regulation); REG. NAKL. NCH changes the amplification differently for different frequencies in accordance with the law of line attenuation change

(slope regulation).

Amplification regulators REG. PL and REG. NAKL are controlled by the control current receivers (PKK-1 and PKK-2), which are connected to the output terminals of the last amplifier in the group route US. PR.

The regulation consist of switching the elements of artificial lines by turning the rotors of capacitance switch, which is brought into motion by a motor, which is connected by a special circuit, controlled by converted signals of the control currents (UPR. ARU). Correct action of the automatic level regulation system provides stability of the level at the receiver route output with an accuracy - + 0.05 nepers.

The K-22 filter and the D-88dop filter, which is placed farther. Increase the reception route attenuation at frequencies outside the operation band. The initial slope equalizer (VYR. NACH. NAKL. NCH) is placed between these elements. The frequency characteristics slope is such that the attenuation for lower frequency range 36 to 84 kc exceeds the attenuation for upper frequencies of the same range by 0.4 to 0.6 nepers. Using such equalizer, which partly compensates the line attenuation frequency characteristic slope, makes it easier to accomplish the alternating slope regulation REG. NAKL. NCH, since the regulation levels are drawn together.

One more equalizer VYR. PR. A, which corrects the amplitude frequency distortions introduced by reception route elements, is placed after D-88dop filter.

Group convertor GP-1, following after this equalizer, "carries over" the operation frequency-band from the linear spectrum to the frequency range 400 to 448 kc, separated by filter GPF. Since the linear spectrum has several alternates, then the carrier-frequency, applied to convertor GP-1 has several values.

The reception route section from filter D-88 to filter GPF which was examined by us has a different construction for office A and office B. Elements used in office A were listed above.

In office B the K-88 filter is set in place of filter D-88, and after it the filter D-153 sometimes called the filter-roof. This last filter introduces into route a considerable attenuation for currents with frequencies

over 153 kc, by which it protects the telephone transmission from radio broadcasting station interferences. After filter D-153, the regulated artificial lines of the flat and slope regulations are connected (REG. PL. VCH and REG. NAKL. VCH), the purpose of which was explained when office transmission route was studied.

The difference between amplification regulators of office a and office b is in the range of the regulated frequencies and in the regulation units.

The initial slope equalizer VYR. NACH. NAKL. VCH, placed in the route after the regulators, having the same purpose as the equalizer VYR. NACH. NAKL. NCH in office a, introduces the lower frequencies of the range 92 to 143 kc and attenuation by 0.2 to 0.3 nepers greater than for the upper frequencies of the same range.

In view of the small attenuation introduced by filter K-88 for currents of low frequency transmission direction (up to 84 kc), into the reception route after the preliminary slope equalizer the filter K-88 dop is connected, which precedes another equalizer VYR. PR. B, which corrects the amplitude frequency distortions introduced by the group route elements.

The first group reception convertor (GP-1) in office b accomplishes the same function as that in office a, however the carrier frequencies applied to it from the generator equipment, have different values (depending on the spectrum alternate).

The reception route part beginning with filter GPF and following after convertor GP-1, is similarly constructed for both office types.

The second group convertor GP-2 in the reception route converts currents of frequency-band 400 to 448 kc into currents with frequencies 60 to 108 kc with the aid of 340 kc carrier frequency. The filter D-200 used in the transmission route turns out to be useful also for the separation of frequency-band 60 to 108 kc after the convertor GP-2. The received signal level at the output of filter D-200 has a very small value. Because of this it is necessary to place the amplifier US. PR, which has such an amplification which provides at the input of individual equipment part a level equal to - 0.6 nepers. The reception amplifier has two outputs: to one is con-

ected the reception route of individual equipment and to the other — the control current receivers (PKK-1 and PKK-2).

In office A, these receivers are tuned to frequencies 64 and 104 kc, and in office B, depending on the spectrum alternate, to frequencies 60 and 111 kc or 58 and 109 kc.

From the amplifier US. PR. the different channel currents enter the channel filters PF and after them to the demodulators DM, which restore the original voice-frequencies spectrum. With the demodulation in each channel the same carrier-frequency as that with the modulation is used.

It should be noted that the upper side-band, formed after demodulation, falls into the high-frequency region, and therefore no special filter is required to separate it from lower-frequency band. The necessary current suppression of the upper-frequency side band is provided by a capacitor connected at the demodulator output.

The reception route of the terminal office is completed by the low-frequency amplifier UNCH and by the differential system DSO which is also involved in the transmission route formation.

The low-frequency amplifier raises the signal level in the channel up to a value which provides the reception of the necessary value of over-all circuit attenuation. Exact determination of the over-all circuit attenuation is made by the amplification regulator which is in the UNCH amplifier.

Those places of transmission and reception routes are shown on the block-diagram (Fig. 2.1), to which equipment is connected for broadcasting transmission in doubled channels; they coincide with the input and separation places of the control currents.

2.2 Tandem office

The block-diagram of tandem office FV-12-2 is illustrated on Fig. 2.2. This office amplifies currents transmitted by aerial line in the 12-channel system spectrum, and also holds constant the level value at the office output.

Fig. 2.2 Block diagram of tandem office V-12-2 - Key

1. Complete by-pass
2. K-3 equalizer
3. By-pass with linear filter
4. Apparatus for branch communication
5. H-f flat regulation
6. H-f slope regulator
7. H-f initial slope equalizer
8. A-B equalizer
9. Matching transformer
10. Derived channel equipment
11. B-A equalizer
12. L-f initial slope equalizer
13. L-f flat regulator
14. L-f slope regulator
15. 3-Channel system
16. Line
17. UPR ARU

Level values, shown on the diagram, are given for maximum office amplification and for currents with frequencies 84 kc (direction b-a) and 143 kc (direction a-b).

There are common elements from the line side for both transmission directions: matching device SU, linear filter set (of which filter K-33 is in the current route of the 12-channels system) and the matching transformer connected between the filter K-33 and the directing filters.

In the transmission direction a-b the first element is the directing filter K-88, which separates the upper-frequency group from the lower. Further D-153 filter is placed, which is necessary for interference suppression, appearing with the operation of broadcasting radio stations. Two amplifying devices REG. PL. VCH and REG. NAKL. VCH, following after D-153 filter, introduce amplification into the route, the value of which varies depending on the attenuation variation of the line section, which precedes the tandem office.

Both regulation amplifiers (or, as they are frequently called, the regulated artificial lines, since virtually varies not the tube circuit amplification but the attenuation of the input amplifier circuit consisting of complex equalizers) are controlled by control currents, formed by the control channel receivers (PKK-143, PKK-92) by the means of the special circuit (UPR ARU). All things considered, these currents will act on the switching element mechanism of units REG. PL. VCH and REG. NAKL. VCH, by which is provided the holding of the output office level at a constant value.

The equalizer VYR. NACH. NAKL. VCH, shown in the diagram after REG. NAKL. VCH, in the range 92 to 143 kc creates a constant slope of the amplification route frequency characteristic in the order 0.2 to 0.3 nepers, with which it narrows the alternating regulation range, i.e. makes the accomplishment of regulated artificial lines easier.

Filter K-88 dop supplements the attenuation of the directing filters K-88 in the retardation band, contributing to the attenuation increase in the intermediate office loop and providing by this parameter the necessary norm 4.0 nepers in the operation band and 2.5 nepers

outside the frequency-band.

The route equalizer VYR. A-B eliminates distortions introduced by the route elements, determining the required uniformity of its frequency characteristic.

One of the most liable units, entering into the tandem office, is the linear amplifier LUs which increases the signal level by more than 6 nepers. The guiding filter K-88 completes the studied route with direction a-b.

The guiding filters D-88 are the first and last elements in the route of transmission direction b-a. The flat and slope regulation devices REG. NAKL. NCH and REG. PL. NCH are connected after the first filter D-88, whereupon indistinction from direction a-b there is only one amplification element. The control of these regulation artificial line is accomplished by control current receivers (PKK-40 and PKK-80) and other elements of the ARU equipment.

Filter K-22 produces the given route and addition attenuation for the currents of three channel systems (V-3). Besides this the appearance possibility of inter-coupling for excitation in the loop, formed by the tandem station V-3 and V-12-2 routes, is excluded.

Following unit in the block-diagram is the equalizer VYR. NACH. NAKL. NCH creates a preliminary slope of the frequency characteristic by 0.4 to 0.6 nepers in the frequency range 36 to 84 kc, thus making easier the accomplishment of alternating slope regulations.

Filter D-88 dop serves for the attenuation increase over the loop, formed by both transmission directions routes of the tandem office. The equalizer VYR. B-A connected after it eliminates distortions of the low-frequency route frequency characteristic, introduced by filters of the given route, including also the filter D-88 dop. The linear amplifier LUs, the next to the last element placed in the low-frequency route, amplifies signals by value in the order of 6 nepers.

Besides the above described principle equipment, the tandem office has also some auxiliary devices.

Since from this office, the distance power supply feeding to the auxiliary repeater office (VUS-12) can be accomplished, then on the PV-12-2 rack the distance

feeding panel PDP installation with measuring device and switching elements is provided, and also the panels of distance feeding chokes DDP.

For the organization of order circuit at low-frequency, the filters DK-2.8 and DDK-2.8, which can be connected after filter D-33, are placed on the same tandem office rack. The office diagram is accomplished with a consideration of possibility of the arriving channels from linear spectrum and branching of the broadcasting program.

The derived channel equipment is connected between route equalizers and linear amplifiers in each transmission direction, whereupon a special transformer is provided for this purpose in the tandem office rack. The broadcasting program branching of equipment is connected parallel to the linear amplifier output.

2.3 Derived channel equipment.

The block diagram of derived channel equipment is shown in Fig. 2.3. As it was already stated above, at the point where the given equipment is placed, derivation of 4-channels can be accomplished and namely channels 9, 10, 11 and 12. These channels occupy linear spectrum sections, which are adjacent to the boundary frequencies of the guiding filters.

Naming the point as office V where the derived channel equipment is arranged, we will agree to designate:

- a) the transmission direction of upper-frequency group from office A to office B - direction A-B;
- b) the transmission direction of lower-frequency group from office B to office A - direction B-A (in directions A-B and B-A transmission of 8 non-derived channels is going on);
- c) the transmission direction from office A to office V - direction A-V;
- d) transmission direction from office V to office A - direction V-A (transmission through 4 derived channels from the side of office A is going on in directions A-V and V-A);
- e) the transmission direction from office V to office B - direction V-B;
- f) the transmission direction from office B to office V - direction B-V (transmission through 4 derived channels from office B is going on in directions V-B and B-V).

Fig. 2.3. Block diagram of derived channel equipment.

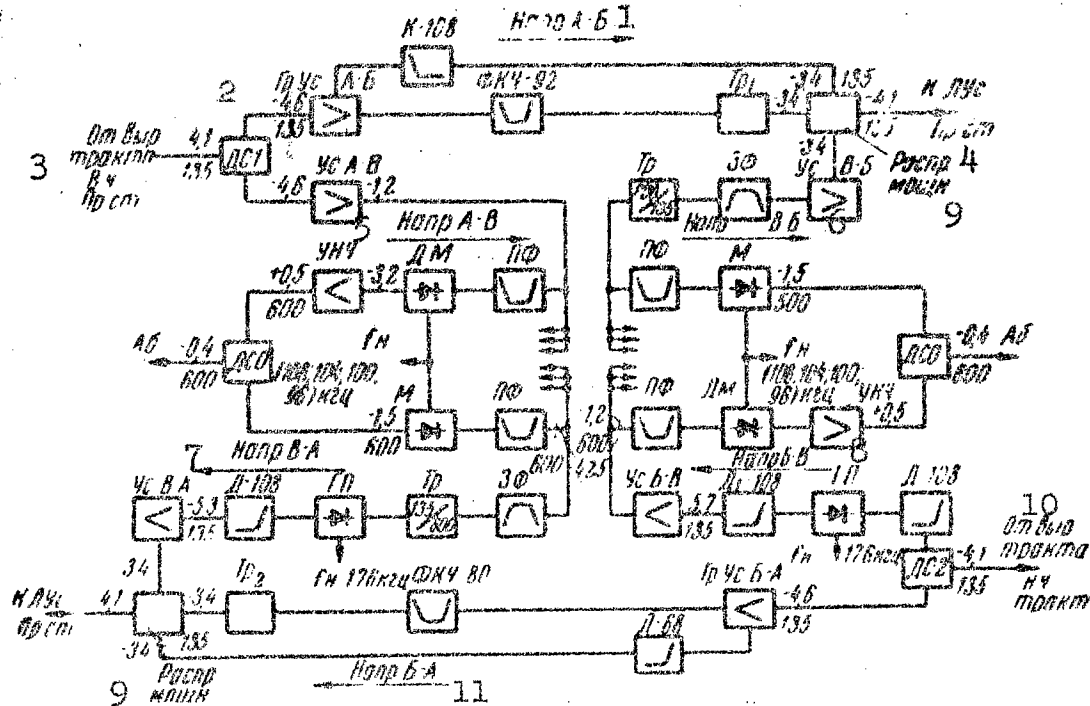

Office V with the aid of derived channel equipment obtains the possibility of communication organization through 4 telephone channels with office A and also with office B. The frequency routes of derived channel equipment are connected to the tandem office in front of the linear amplifier input for both transmission directions.

In direction A-B and B-A two routes are formed: one for eight telephone channels and the other for control frequencies falling into the spectrum of four derived channels - 92 and 80 kc.

First and common element of these routes is the differential circuit DS-1 (or DS-2), which divides the circuits of 8-channel and 4-channel groups. Further in current path of the first group the group amplifier GR.US. A-B (GR.US. BA) is placed, which compensates the attenuation introduced by passive route elements and first of all by the filter K-108 (or D-68). In the GR.US. A-B (GR.US. B-A) the high-frequency (or low-frequency) transmission direction currents are amplified, including also the control current with frequency 92 (or 80) kc.

Fig. 2.3 Block diagram of derived channel equipment. Key.

1. Direction A-B
 2. Group amplifier (GrUs)
 3. From VCH (high frequency) route equalizer of tandem office.
 4. To LUS (line amplifier) of the tandem office.
 5. Direction A-V
 6. Direction V-B
 7. Direction V-A
 8. Direction B-V
 9. RASPR MOSHCHN (Power distributor)
 10. From equalizer route
-
- NCH (1-f) route
11. Direction B-A

After this amplifier two filters are connected: 1. quartz filter K-108 (or D-68), which derives the 8-channel group, suppressing the currents of other 4-channels; 2. narrow-band quartz filter FKCH-92 (or FKCH-80), which passes the control frequency current.

FKCH-92 is loaded by matching transformer Tr_1 (or Tr_2); the device following after the transformer is called the power distributor (RASPR. MOSHCHN, which joins three different routes (control signal (8-channel and 4 channel) into one common route, eliminating their mutual influence. The distributor RASPR. MOSHCHN output is connected to linear amplifier of the tandem office.

In direction A-V there is an amplifier $Us. A-V$ after the differential system ds-1, which provides a necessary level at the input of 4 parallel connected channel filters PF. These filters divide the frequency-bands of the 4 derived channels (92 to 96, 96 to 100, 100 to 104, 104 to 108 kc) and at the same time they are also the individual equipment elements for each of them.

The individual equipment constitution in the derived channel equipment is standard, i.e. it is the same as in the terminal office: channel-band filter PF, demodulator DM, low-frequency amplifier UNCH and differential system with limiter DSO.

Thus the reception of 4 derived channel currents is accomplished.

In direction V-A the currents of the same 4 channels are transmitted. After the individual part of the equipment ending with filter PF, a group route of these channels is formed, the first element of which is the band elimination filter ZF, which suppresses the current remainder of the carrier-frequency 96 kc. Further after the matching transformer $Tr_{135/600}$ follows the group convertor GP, which is necessary to transpose the group spectrum of 4-channels (92 to 108 kc) into the lower group frequency 68 to 84 kc linear spectrum section derived for them. Conversion is made with the aid of 176 kc carrier-frequency, which was produced in the harmonic generator device of the derived channel equipment. The given value of carrier-frequency determines the necessity of filter ZF installation. With absence of the latter the current remainder with frequency 96 kc,

getting into the convertor, will cause at its output, and consequently, in the line the appearance of current with frequency 80 kc ($176 - 96 = 80$), which in its turn will get into the control channel and will knock off the level regulation.

Filter D-108 (the next element of the studied route) suppresses the useless conversion products, and the amplifier Us. V-A increases the signal level up to a value, which with the consideration of attenuation in the distributor RASPR. MOSKCHN will provide the required value - 4.1 nepers at the linear amplifier input of the tandem office.

In direction V-B the 4-channel currents, transmitted to office B after individual conversion, are joined into a group with spectrum 92 to 108 kc.

The group route contains matching transformer Tr 600/135, band elimination filter ZF, amplifier US. V-B and power distributor.

In direction B-V, the derived channel group after the differential system DS-2 gets into the filter D-108, which protects the 8-channel route from conversion products, formed in the group convertor GP. After this convertor one more filter D-108 is connected, which limits the useful frequency band for further conversions. Individual equipment elements for the four derived channels are connected after the amplifier Us. B-V.

Chapter 3. Individual Equipment

3.1 General information

By individual equipment are understood all those equipment elements and units which enter only into a route of each separate channel. Also the devices serving for switching and pressing of channels are usually added to this equipment. Thus, differential systems and amplitude limiters VSO, modulators and demodulators M and DN, channel filters KF, low-frequency amplifiers UNCK, voice frequency ringing and dialing receivers PTNV, relay such, operating in the call signal receiving and transmitting circuits RTV and RIV, and also the voice frequency ringing generators GPV, control in switching sockets,

speaker-buzz device PVU, neper meter NP and test amplifier IUs enter into the constitution of individual equipment.

In equipment V-12-2 all listed units are arranged on one rack, forming the individual equipment rack SIO. If 12-channels sets are installed on rack SIO, then it is called the SIO-12 rack, and for 24 sets, then SIO-24. (*Sometimes these racks are also called SIO-1 and SIO-2). Such outfitting permits to use the rack in different multiplexing systems. Already at present the SIO-24 racks are applied in the 24 and 60 channel systems of high-frequency telephony through cable lines (K-24 and K-60), in the 12-channel system operating on single cable lines (KV-12), and also in the radio relay lines multiplexing systems.

Channel characteristics are determined mainly by the quality of unit performance and the time stability of individual equipment. The amplitude frequency characteristic of the overall channel attenuation depends first of all on the attenuation characteristic of channel filter. The amplitude characteristic and the coefficient of non-linear distortions in the channel are determined by the operation of amplitude limiter and low-frequency amplifier. The intelligible and unintelligible cross talk to neighboring channels can sometimes be explained by filter defects and so on. Stability of frequency and output level of the voice-frequency ringing generator in conjunction with sensitivity and selectivity of voice-frequency ringing-dialing receiver and the correct relay operation, determines the operation of semi-automatic communication system and the passing of call signal.

Operation of SIO units also tells on the group equipment characteristics. For example, with insufficient suppression of carrier current remainders or with oversized output level, the group devices cannot overload, distortions and noises and also transient currents in other circuits cannot arise.

It is clear from the given examples that in the terminal office it is necessary to watch the condition of individual equipment, although measures were taken in the equipment to maintain stable system operation for a long time.

The presence of large number of identical units in rack SIO (differential system, converter, UNCH-PTNV, etc) in necessary case permits to accomplish easily their re-arrangement between channels or arrangement of reserve units, which are recommended to be kept in readiness.

3.2 Block diagram

The individual equipment rack diagram is given on Fig. 3.1 with the indication of level values in different route places does not require a detailed explanation, since the general block diagram of terminal office was examined above.

We will only note here that these routes are of the same type for all channels. The channel number determines only the characteristic and elements of channel filters (KF) which depend on the operating frequency range. When 12 filters KF are connected in parallel, it is necessary to correct their total output (or input) impedance. This correction is accomplished by circuit KK.

A series of jacks is shown on the diagram. The separation jacks are installed in the two wire and four wire routes, and also in the call signal transmission circuits; the control jacks are placed at the high frequency input and output of the rack and in the carrier frequency current feeding circuits. These jacks permit to check separate route sections, to accomplish tandem connections, to measure the level at different circuit points, etc.

Transformer Tr.per and attenuator U_{d_v} are the last elements of the SIO transmission route.

Transformer Tr.per and also transformer Tr.pr are made according to a differential circuit and have three output terminal pairs. Transmission route is connected to the first terminal pair, i.e. the band filter output; attenuator U_{d_v} is connected to the second terminal pair, and the third terminal pair is used for the connection of equipment for broadcasting which is transmitted by doubled channels.

When using SIO racks, making contacts by cable lines, in the terminal offices the attenuator U_{d_v} is disconnected, as a consequence of which the output level increases by 0.3 nepers and becomes equal to -4.5 nepers.

Fig. 3.1 Block diagram of individual equipment

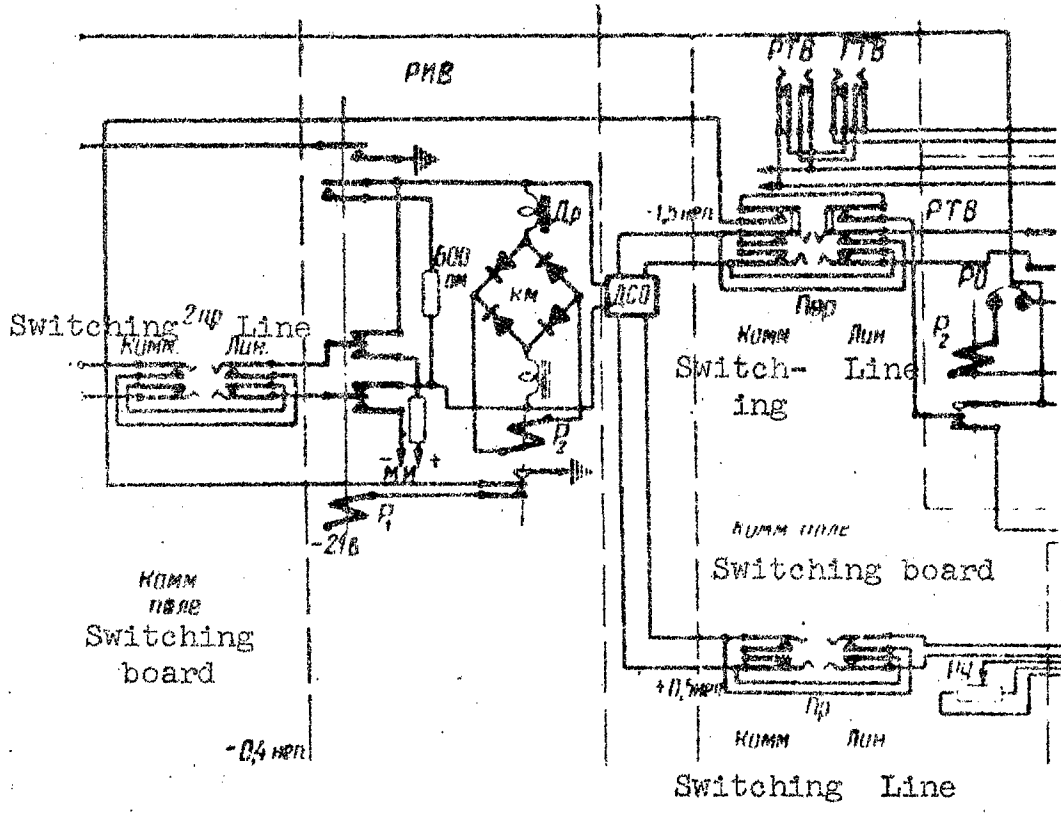
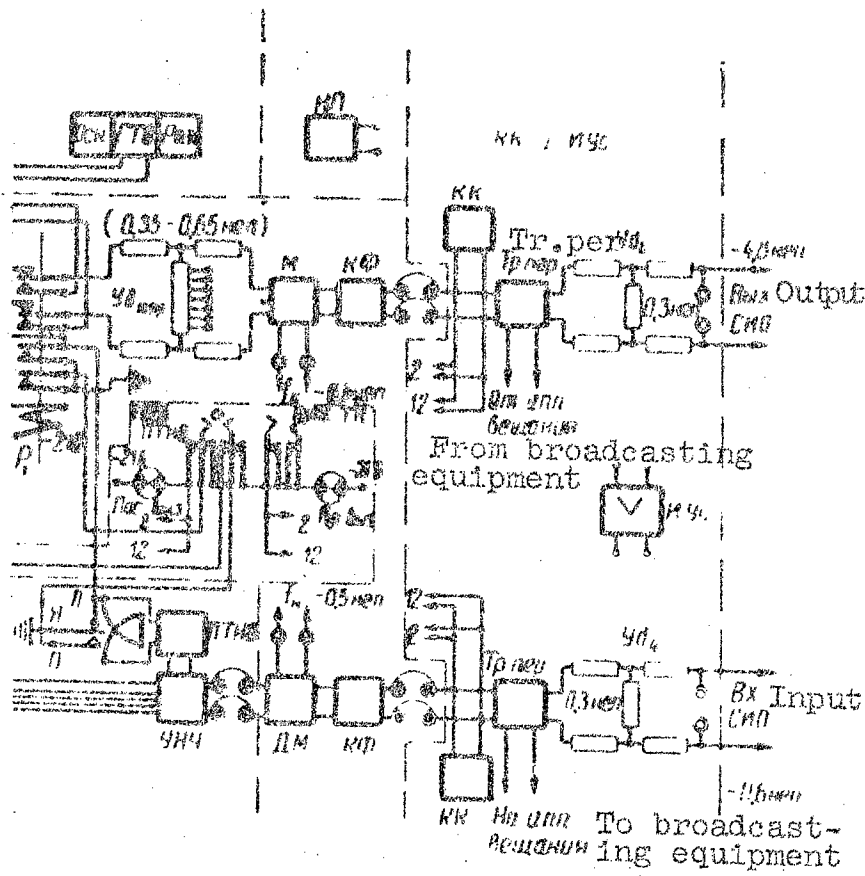

Fig. 3.1. (Continuation)



A detailed description of units, included in the SIO rack, is given below, but the given circuit will also be used to explain the different parts interaction in the individual equipment.

3.3 Differential system and limiter (DSO)

The differential circuit divides the two wire route which is common for both transmission directions into two reception and transmission routes, which together form a four wire route.

The amplitude limiter is connected into the transmission route and is intended to protect the group devices from the increased levels of speaking currents, which can appear with short subscribers lines or with loud speech and can cause amplifier overload, which first of all, will influence the operation of voice frequency carrier telegraph.

Differential circuit and amplitude limiter form a single circuit (Fig. 3.2) and single structural unit in the individual outfitting of the V-12-2 equipment. Transformer Tr_3 is the basis of differential system. The blocking capacitor C_1 , which decreases the shunting transformer action for ringing currents, is connected from the switchboard to this transformer.

Resistance $R_1 = 600$ ohms and two capacitors $C_2 = 0.5 \mu\text{f}$ and $C_3 = 1 \mu\text{f}$ are the balanced load of the differential system.

The attenuators Ud_1 ($b = 0.25$ nepers), Ud_2 ($b = 0.30$ nepers) and Ud_3 ($b = 0.25$ nepers), which serve to establish nominal values of measuring levels in two wire and four wire switching jacks, are in the transmitting and receiving branches of the differential system.

Input impedance of differential system from the switching board side equals 600 ohms. A capacitor $C_4 = 0.01 \mu\text{f}$ is placed into the transmission rack of the differential system to compensate for the reactive component of this input impedance.

Resistance R_g , which = 600 ohms serves to match the 300 ohm differential system output with the 600 ohm limiter input.

Fig. 3.2 Differential system circuit with limiter.

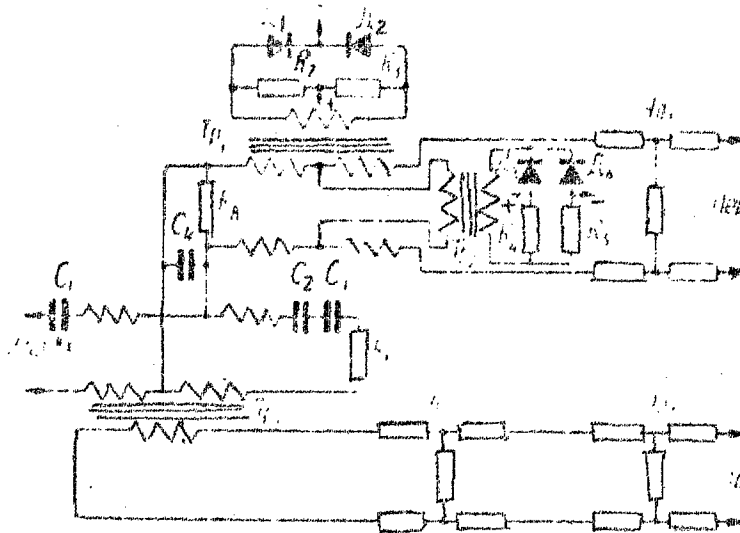

The amplitude limiter is an unbalanced differential system, made with the differential transformer Tr_1 . Germanium diodes D_1 and D_2 are connected to one input of this differential system, and diodes D_3 and D_4 (type D2B) are connected through transformer Tr_2 to the other input. The first two diodes have a positive bias from a battery, and the other two a negative bias.

With the absence of a call and with normal speaking current levels, the diode resistance is determined by the bias voltage from the constant current source.

When at the input a speaking current limiter with increased level is placed, the alternating voltage on the diodes is greater than the constant voltage bias. The diode resistances in this case change such that the amplitude limiter attenuation increases. Indeed, the resistance of series connected diodes D_1 and D_2 at high signal levels increases, and decreases with parallel connected diodes D_3 and D_4 . All things considered this leads to an improvement of differential system balancing (Tr_1), i.e. to the increase of its attenuation.

The amplitude characteristic of the differential system transmission route with limiter is represented on Fig. 3.3. The operating attenuation of this differential

system route with normal levels equals 1.1 nepers and of the receiving route 0.9 nepers.

Differential system and limiter are installed in one unit, having small dimensions (32 by 90 by 140 mm) which permit to arrange 12 such units on a mounting plate 120 mm wide.

Fig. 3.3 Amplitude characteristic of differential system with limiter

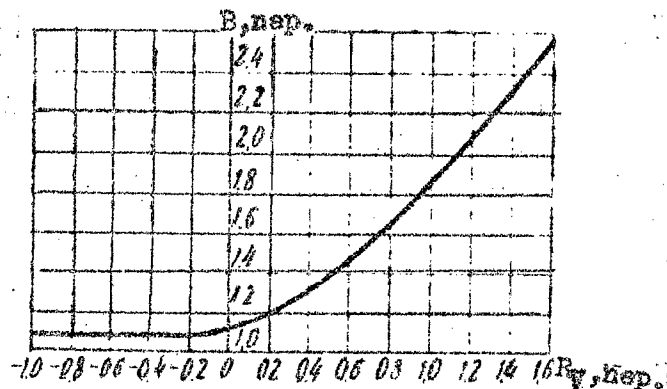

All DSO unit transformers are made with permalloy cores, which makes it possible to decrease substantially their sizes.

The necessary switching of elements (attenuators, balancing circuits and others) are accomplished by resoldering at the terminals, placed on the front turbonit unit cover.

3.4 Individual frequency converters and channel filters

Individual frequency converters enter into transmission route (modulators) and into the reception route (demodulators) of each channel.

The frequency band of speaking currents is converted in the modulators to the high frequency band which occupies depending on the channel number (i.e. on the carrier frequency value) a definite section in the principle 12 channel group spectrum 60 to 108 KC.

Demodulators make a reverse conversion of high frequency signals into low frequency signals with the aid of the same carrier frequency which is used in the modulator.

From the point of view of economic and uniform consumption of energy by the converters from the carrier

frequency current source, it is advisable to oppositely connect the modulator and demodulator diode bridges in each channel from the side of carrier frequency feeding, i.e. in such a way that one half would "open" the diodes, e.g. the modulator, and the other the demodulator.

The lower side band derived by the band channel filter after the modulator is the operation band for transmission and also for reception after the conversion.

The diode bridge (Fig. 3.4) which is made from cuprous oxide rectifiers MKV5-1 is the basis of modulator and demodulator circuit.

Fig. 3.4 Circuits of individual converters.

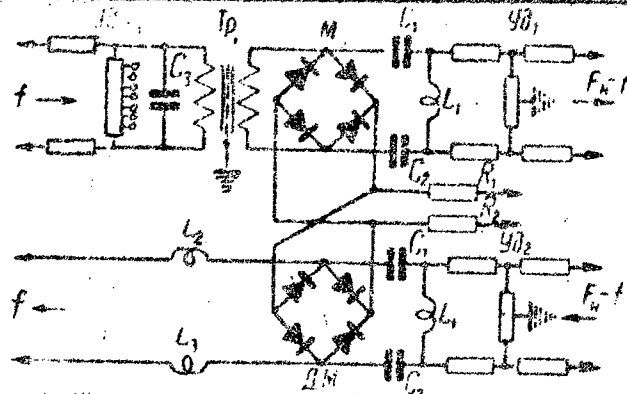

The attenuators Ud_{per} ($b = 0.35$ to -0.65 nepers) and Ud_1 ($b = 0.8$ nepers) are connected in front and after the modulator, and they make its balancing with the loads easier, in the first place with the band filter. Besides this, these attenuators permit to change their attenuation by changing (3 solderings) the arm resistances and by this permit to establish the exact required level value at SIO output.

Attenuator Ud_2 ($b = 0.8$ nepers), having the same purpose, is placed in front of the demodulator. Protection of low frequency circuits from high frequency signals getting into them is provided by low pass filters, formed by transformer Tr_1 binding and capacitor C_3 and also by the coils L_2 , L_3 and the input capacitance of low frequency amplifier.

On the other side, the high pass filters the elements of which are L_1 , C_1 and C_2 suppress the low frequency currents at the modulator output and demodulator input.

The attenuation of each individual converter is 1.0 to 1.1 nepers. The above mentioned low pass and high pass filters which eliminate the shunting of operating signals by converter loads aid the decrease of attenuation.

It is important for the modulator to have such a selection of bridge elements (4 rectifiers), which would provide a minimum leakage of carrier frequency current to the circuit output. With great similarity of these elements it is possible to reach the level of carrier frequency current remainder at the modulator output equal to -5 nepers (usually -4.5 nepers).

All unused conversion products in the transmission route are suppressed by band filter. In the reception route similar filters derive only one channel band from the frequency range 60 to 108 KC.

Since frequency bands arranged between channels have relatively small width, then the requirements for filter attenuation increase outside the pass band are very high. Such an attenuation characteristic steepness on the spectrum sections adjoining the pass band together with high parameter stability can be provided by filters with piezo crystal resonators which at our place are even made from natural quartz or from artificially ground crystals.

A typical characteristic of channel band filter is given on Fig. 3.5. The filter consists of two bridge circuit sections matched by resistors R_1 to R_6 . The input and output filter resistances equal 600 ohms.

The circuit element values and the pass band are determined by channel number.

Parallel connection of 12 filters involve the distortion of their attenuation characteristics and the increase of reactive component of input impedance. Its compensation is made by connecting the special circuit KK (Fig. 3.1) which is a four element tube terminal network.

Structurally the panel of individual channel converters PIK (1 for 3 channels) contains 3 modulator blocks, 3 demodulator blocks and 6 individual channel filters. All these units are placed on a frame made from flat bar steel, they are braced together by screws, accessible from the front and if necessary could be taken

off without difficulty.

Fig. 3.5 Circuit and characteristic of the channel band filter.

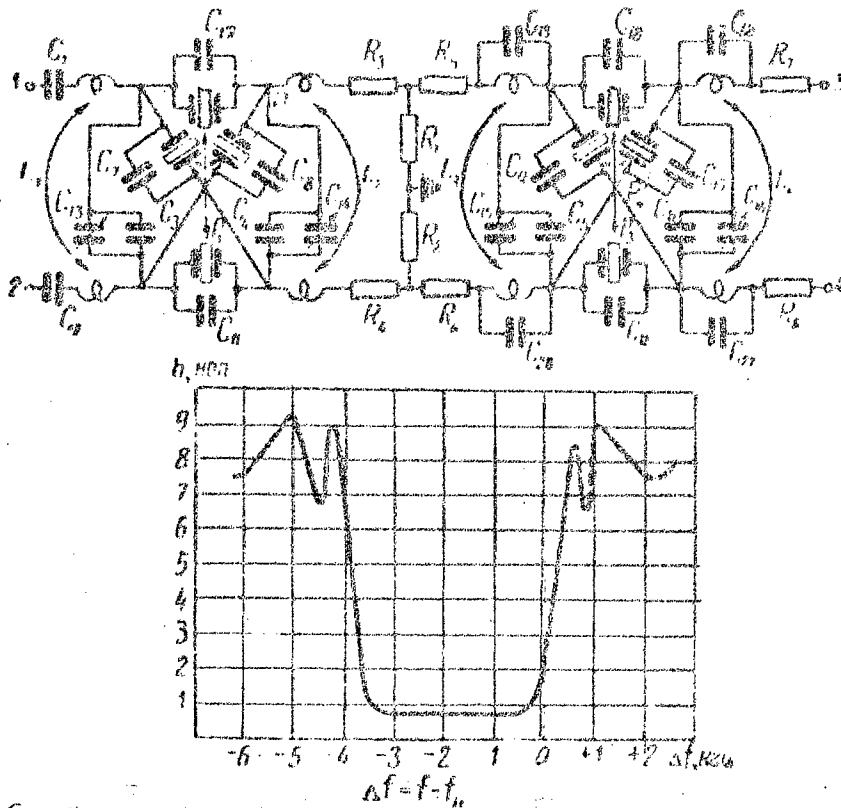
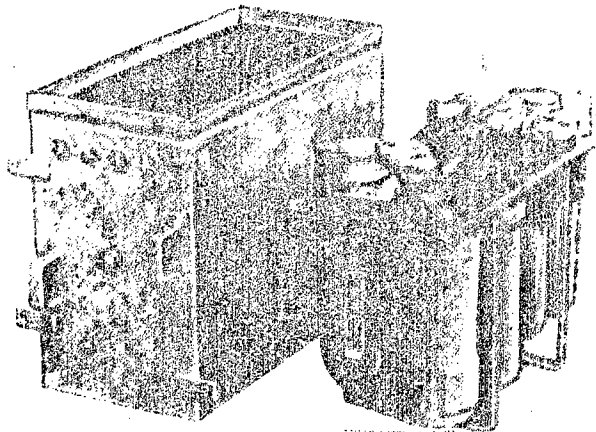
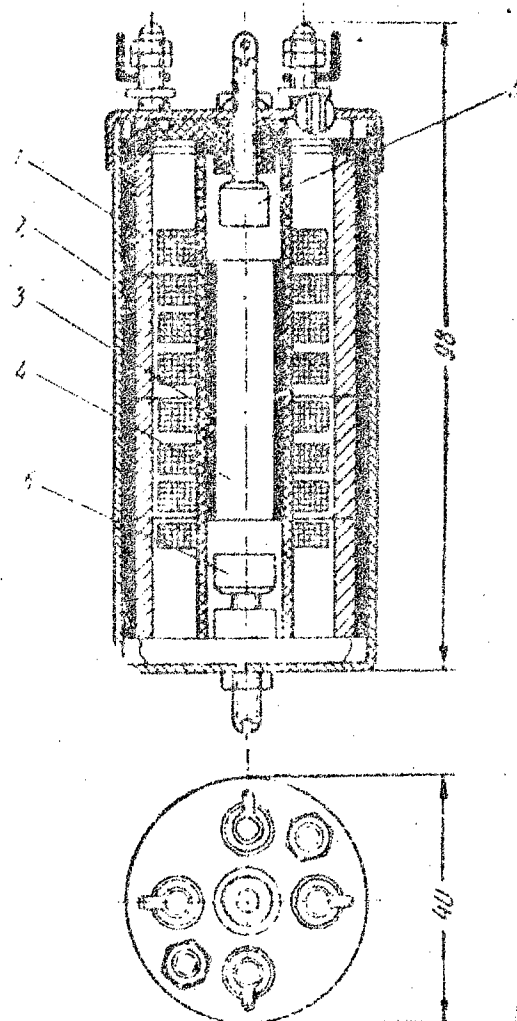

Fig. 3.6 Channel filter with cover.



Channel filters are made with piezo electric resonators and inductors with ferrocart magnetic circuit. The filters are mounted on a chassis fixed inside a soldered cover. The external view of the channel filter is shown on Fig. 3.6. The inductor used in the filter (Fig. 3.7) was suggested by L. I. Rabkin (NIITS). The application of ferrocart permits to reduce its overall size dimensions by more than half with respect to a coil without a core.

Fig. 3.7 Inductance coil of the channel filter.



Four ferrocarr rings (1) with permeability $\mu = 400$ which make the external cylinder of inductance magnetic circuit are enclosed in red copper case (2). Inside this cylinder a coil is placed which has a ceramic tube (3) as a frame for windings. Universal type winding is made in sections. The core (4) and also the small adjustors (5) are placed inside the ceramic tube.

3.5 Low frequency amplifier and voice-frequency dialing-ringing receiver.

The low frequency amplifier (UNOH) and the voice-frequency dialing and ringing receiver (PTNV) are combined into one unit and form one common circuit illustrated on Fig. 3.8. The circuit contains two tubes 6ZH1P-E. One of them is in the amplification stage which is common for speaking currents and call signal. The second stage differs only to the PTNV receiver and circuits are connected at its output which determine the receiver selectivity and its protection from random operations owing to components in frequency close to 2100 c contained in the speech spectrum.

The amplifier input transformer (Tr_1) is made with ferrocarr core with $\mu = 2000$. Two resistances one of which is variable are connected parallel to the primary winding. It is used as amplification control (RU) and is placed on the switchboard outside the unit (UNOH-PTNV). The control RU changes the amplification in the range 1.1 nepers.

The amplifier output transformer (Tr_2) is an unequal branch differential system designed from the condition of minimum losses of the speaking signals used for power in the voice-frequency dialing-ringing receiver, and also from the condition of the best receiver protection from interference currents entering from the switchboard.

A combined feedback (C_4 , R_6 and R_3 , R_4 , R_6) which encompasses the output transformer is introduced to improve the amplifier characteristic. The feedback depth equals 1.5 nepers in the frequency range, 300 to 3400 c.

The maximum amplifier amplification is 4.3 ± 0.05 nepers, and without the feedback approximately 5.7 nepers.

Fig. 3.8 Circuit of the low-frequency amplifier and of the voice-frequency ringing-dialing receiver.

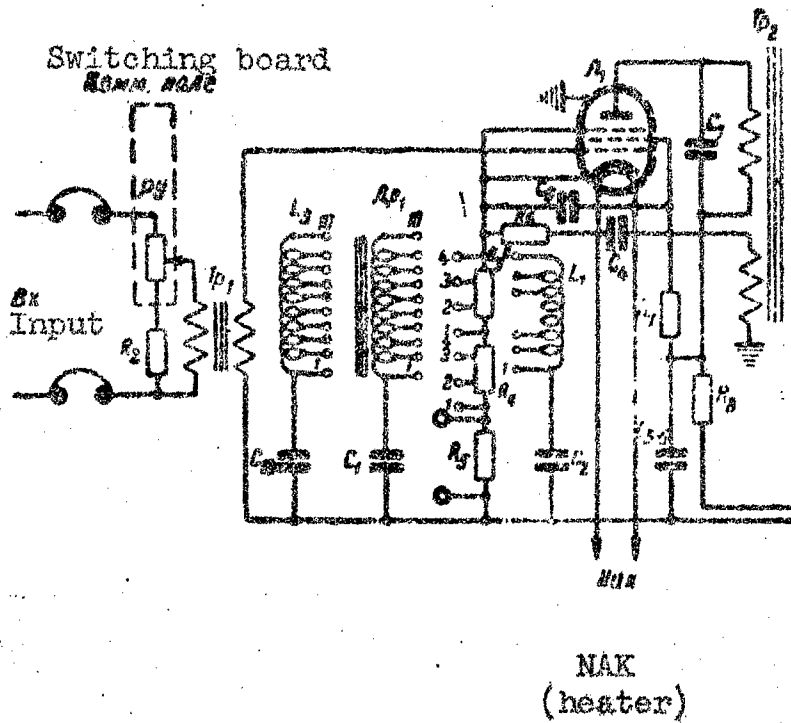
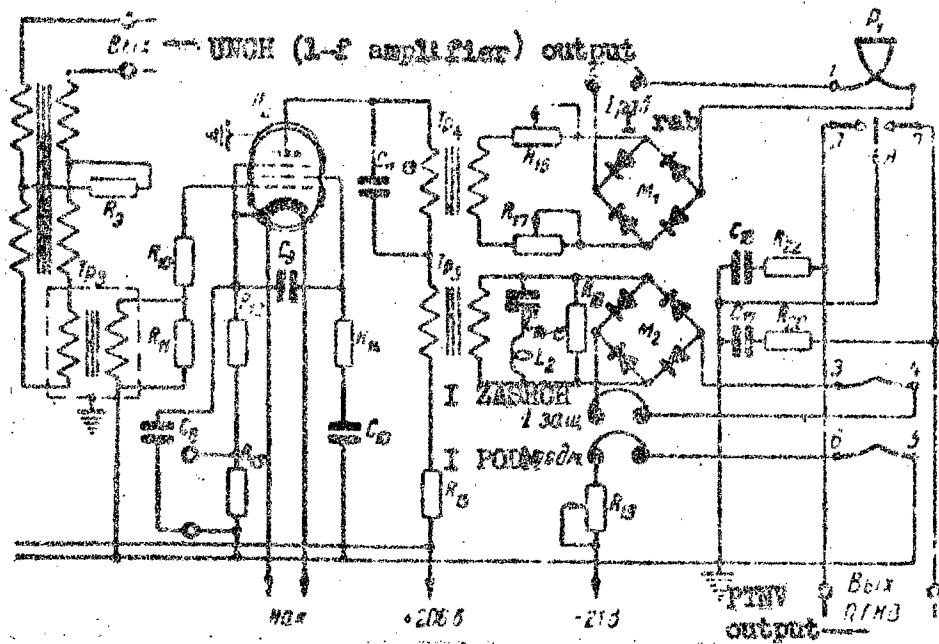

Fig. 3.8. (Continuation).



NAK
(heater)

The amplifier amplitude characteristic maintains the straight line shape with an accuracy of 0.01 nepers up to +1.6 neper level at the amplifier output. The reflection coefficient of the amplifier input impedance with maximum amplification is not greater than 15% with respect to the 600 ohm resistance, with the exception of frequency 300 c where it can be somewhat greater. The reflection coefficient amplifier output resistance with respect to 600 ohm resistance is not greater than 10% in all operation frequency range.

The correction elements of amplifier frequency characteristic ($D_1, C_1; L_1, C_2$ and L_3, C_4) provide a possibility of amplification raise at the ends of frequency range (300 to 700 c; 2300 to 3400 c) in the range 0.5 neper and in the middle of the band (500 to 1700 c) in the range 0.3 neper (Fig. 3.9).

The sending and reception of a call in V-12-2 equipment is made by a 2100 c voice-frequency current.

Fig. 3.9 Frequency characteristics of UNCH with connected compensating circuits.

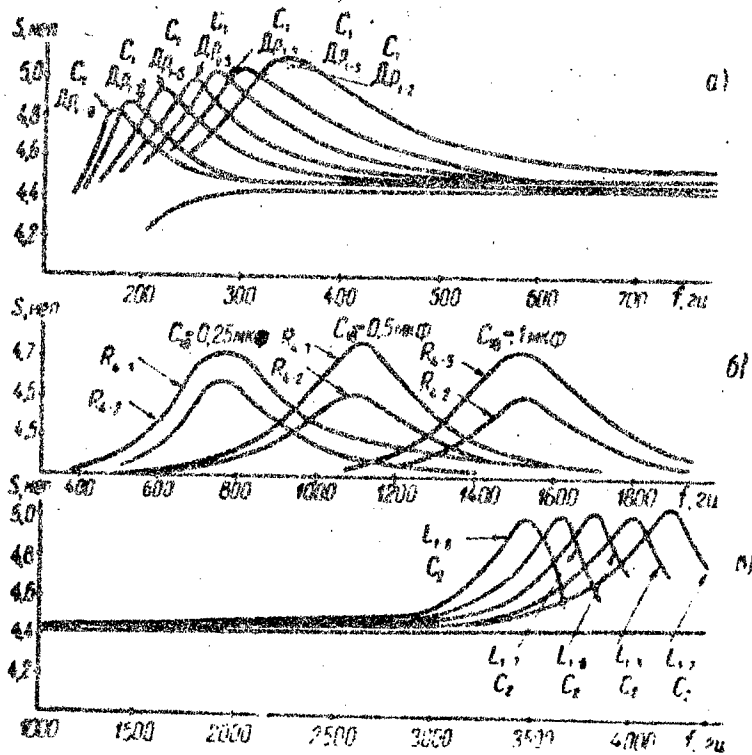

The parallel and series circuit tuned to this frequency are the plate load of the receiver tube. The operating coil of receiving polarized relay R_1 (1-2) is connected through a rectifier bridge to the parallel circuit (Tr_4 C_{11-13}).

The relay drainage coil (3-4) is connected to the series circuit (L_2 C_{14-15}). Its purpose is to hold the relay armature at the nonoperating contact during the time of speaking currents passage and to prevent by this false receiver operation.

Rectifier bridges are made with type D2B germanium diodes.

A field winding (5-6) is introduced which is fed by heater battery to hold the relay armature in non-operation position with the absence of ringing and speaking currents. A current is established in the winding which provides the necessary ampere-turns, determined from the condition of smallest distortions of pulse durations.

The receiver tube operates in the AV conditions. Besides this amplitude limitation takes place at the expense of upper and lower characteristic bends, which is necessary in order that a smallest current dispersal in the relay windings would be obtained, and consequently the smallest distortion of dialing pulses with the signal level oscillation at the block input.

The polarized relay has a stable operation in the UNCH-PTNV unit with level oscillations at UNCH amplifier input in the range 2.5 nepers.

The amplitude and frequency characteristics of PTV receiver are illustrated on Fig. 3.10.

The voice-frequency dialing-ringing receiver operates dependently with simultaneous action of the following unfavorable factors: deviation of the ringing signal frequency by + or - 25 c from the nominal value; minimum or maximum voltage of power supplies; presence of noises with uniform energy spectrum in frequency band 300 to 3400 c and with level -3 nepers at a point where the measuring level equals + 0.5 nepers; level oscillations of the ringing signal at UNCH output in the range from -1.7 nepers to + 0.8 nepers.

The receiver is not sensitive to currents the frequencies of which differ from + or - 100 c from the

nominal (2100 e) with current levels of + 1 neper at a point where the measuring level equals + 0.5 neper. Pulse distortions with the above listed unfavorable conditions do not exceed 6 small nsec with their normal duration 50 to 60 nsec.

Fig. 3.10 Amplitude and frequency characteristic of PTNV, 1) level at the UNCH output - 1.7 nepers, 2) level at UNCH output - 0.2 nep., 3) level at UNCH output + 0.8 nep.

AW of operating coil

AW of relay operation

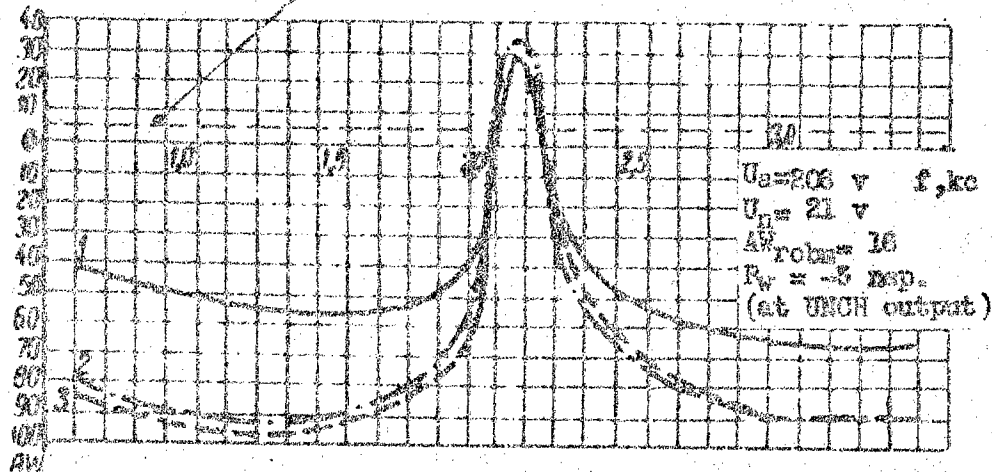

AW of drain coil

Structurally the UNCH-PTNV unit is made in a form of cut-in block. The PTNV receiver elements are in its upper part and UNCH amplifier elements in the lower part. The unit is provided by a 16 contact contactor block placed in the back part of the chassis (Fig. 3.11).

The front block plate has jacks for the measurement of tube currents, currents in relay windings and for parallel connection of measuring devices to UNCH amplifier input and output. UNCH-PTNV blocks are placed on the SIG-12 rack on 4 panels - 3 blocks on each panel. The 3 tube heater filaments of different block amplifiers on one panel are connected in series; also the filaments of PTNV receiver 3 tubes are connected in series.

Fig. 3.11 UNCH-PTNV unit

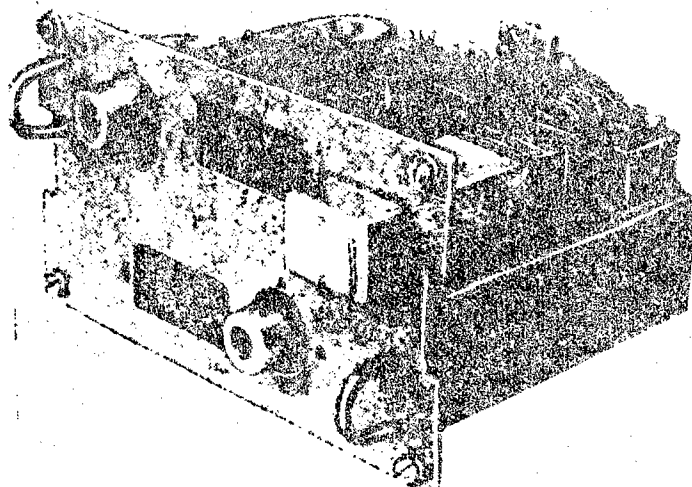

3.6 Voice-frequency ringing generator (GTV)

The voice-frequency ringing generator (Fig. 3.12) has three tubes, two of which L_1 and L_2 form an RC coupled master stage, and the third tube (L_3) amplifies the generated oscillations. The current frequency produced by the generator is determined by elements R_1 , C_{1-2} and R_2 , C_{3-4} ; its nominal value equals 2100 ± 5 c.

The application of negative feedback (resistors R_5 and R_6) and its connection into the thermistor (L_4) circuit aid in the stabilization of output level and the improvement of ringing current curve form.

A circuit consisting of the primary transformer Tr_1 winding and capacitor C_{10} and tuned to the 2100 c frequency is the plate load of the output amplifying tube. Transformer is made with a TCH-50 type torroidal core, having 24 mm outer diameter and 13 mm inner diameter.

The generator has 2 outputs. A current of 2100 c and with level -1.5 nepers is applied to the telephone channels through the first operating output (Vykh.rab); the same signal with level -3 nepers can be applied to 600 ohm UNCH-PTNV input for its checking through the second test output (Vykh.isp).

Signal level coming from the operating and also from the testing output can vary in range ± 0.5 nepers with the aid of variable resistances R_{22} and R_{19} .

A noticing lowering of output level (by 0.3 to 0.4 nepers) owing to the tube aging or as a consequence of other reasons is registered by lamp signalization activated by polarized relay R. This relay is fed by the rectified current applied to its winding (1-2) from the type D2B diodes, which are connected into the IV winding circuit of transformer Tr₁. By lowering the voltage value on this winding the relay armature (as a consequence of ampere turns predominance formed by the magnetizing current) closes with a contact placed in the signal lamp circuit.

The output signal power with 2100 c frequency is provided of such a value that the studied generator circuit, that it is possible to send ringing current through 24 channels at the same time and with this the level at the input of any channel does not become lower than 0.1 neper.

Fig. 3.12 Voice-frequency ringing generator (GTV)

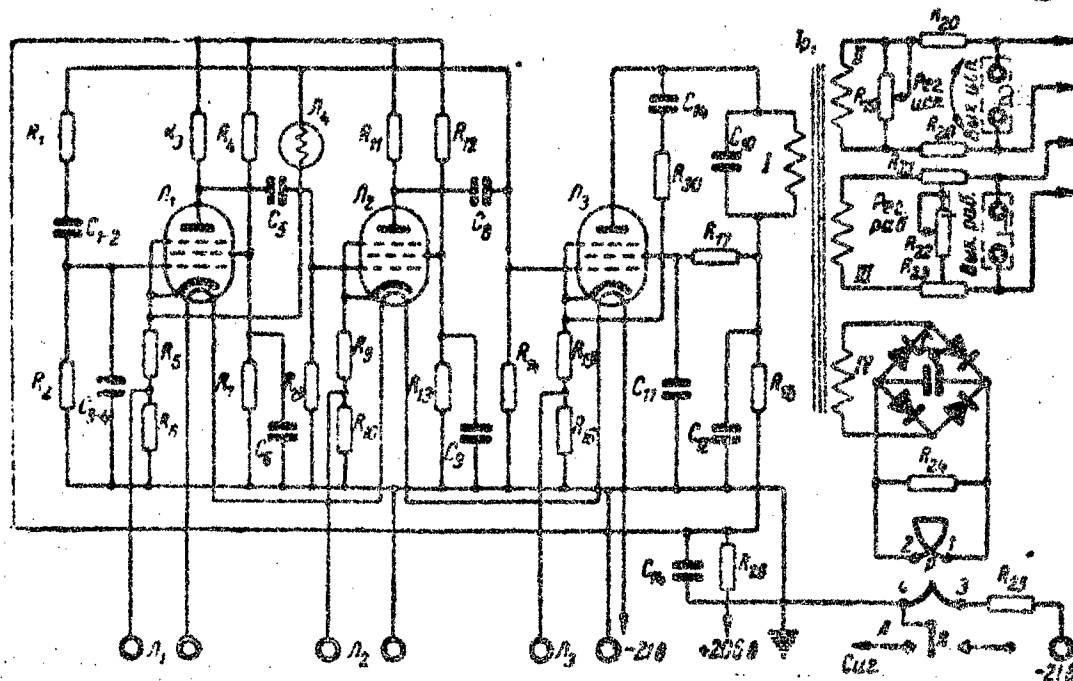

The voice-frequency ringing generator is shaped in the form of cut-in block, on the front panel of which besides the tubes (electron and signal) are placed: jacks of the both outputs, jacks for measuring tube cathode currents, jacks for measuring filament currents, and also

1. Operation output
2. Test output

for regulating output levels (R_{19} and R_{22}).

A reservation of voice-frequency ringing generator is provided in the equipment by another exactly similar generator.

A switch located between the principle and reserve generator blocks can switch over the load from one to the other, in addition to this the signal lamps at the switch mark which one of the generators is feeding ringing frequency current into the channels.

3.7 Joint operation of sending and receiving devices for voice-frequency ringing and pulse dialing

Equipment constitution. The following units and elements of the individual equipment rack (Fig. 3.1) are included in the transmission and the reception circuit of voice-frequency ringing and dialing: a) voice-frequency ringing generator (GTV); b) low frequency amplifier, joined with the voice-frequency dialing-ringing receiver (UNCH-PTNV); c) relay set for ringing devices RIV (magneto ringing relay) and RTV (voice-frequency ringing relay); d) control devices, arranged on the switching field, telephone jacks to check voice-frequency dialing (Prov. TN), buttons to check the sending of voice-frequency ringing (Prov. PTV), signal lamp to control call sending (Pos. vyz), signal lamp to control call interception (Pr. vyz). A dowel to check PTV is installed in the universals PVU lock.

We will examine in order the operation of listed devices first with the sending of ringing current and then with the sending of dial pulses. The first takes place with a manual connection of customers, and the second presumes the realization of semi-automatic connection.

Call sending. Magneto ringing current with frequency of 15 to 50 c incoming from the switchboard passes choke Dr_1 and rectifier bridge KM of the RIV unit. The rectified voltage which appears in the bridge diagonal forces to operate the relay R_2 which forms a circuit by its contact into which enters also the relay R_1 of the RTV unit (the relay R_2 contacts of RTV unit are closed, since relay itself is under current). Relay R_1 operation involves the switchover of contacts, through which the ringing frequency 2100 c is applied from GTV to the

modulator input. The ringing signal passes further through the route in the same way as the speaking signal up to the low frequency amplifier of the other terminal office.

With the operation of relay R_1 RTV the relay R_2 is simultaneously blocked which first was fed through the left contact of PTV polarized relay. This blocking is necessary for the case of simultaneous incoming of a call from the high frequency channel, since without it relay R_2 would drop out as a consequence of circuit break in the polarized relay contacts. Following R_2 , R_1 would also drop out, i.e. the sending of the call would stop.

The call can be also sent by a constant current. In this case the "ground" from the switchboard (with four wire termination of the channel) is directly applied by the connecting wire to RTV relay R_1 and further occurs everything as stated above.

When there is a two wire channel termination, the call sending by constant current is accomplished through the operating pair of wires. The relay R_2 of block RIV also operates, which for this case is connected in series with choke Dr_1 (rectifier bridge is excluded from the circuit).

Operation of relays involved in call sending can be checked by observing the lighting of signal lamp Pos.vyz. in order to make the check, the button Prov. of PTNV should be pressed, which is provided for every channel on the SIO switching board. With this the mentioned lamp Pos.vyz. will light up every time, when the performing relay R_1 of RTV attracts its armature.

Call reception. Getting into UNCH-PTNV block, the call signal with frequency 2100 c is rectified in the PTNV circuit and acts on the polarized relay which is in this block (Fig. 3.1 and Fig. 3.8). The relay armature is thrown over from the left to the right contact, as a consequence of which a circuit is formed through Prov.PTNV which is in a released condition, contacts of RTV relay R_2 transmission route jacks, placed on the switching board, contacts of RIV relay R_2 and finally winding of RIV relay R_1 . The operation of the last relay connects alternating current source with frequency 15-50 cycles (e.g. power ringing generators MI) of constant current 24 volt source, to the two wire channel output. After this the entry of a call is recorded on the switching board.

Control of PTNV operation can be accomplished by forcing the Prov. PTNV key. With this the polarized relay armature is thrown over to the right contact and the lamp Pr.vyz installed on the SIO switching board lights up.

Sending and receiving dial pulses. Sending of dial pulses is made by a relay device which is not included in the SIO rack equipment. This device (outgoing voice-frequency dialing set - IKTN) provides the sending into the channel of alternating current pulses with frequency 2100 c duration 40 to 60 nsec and with intervals of the same order. The alternation speed of pulses and intervals, and also their duration is determined by the rotation speed of the dial disc.

Accomplishment of semi-automatic connection specifies four wire channel termination at SIO. Elements of the two wire route part in this case are disconnected by breaking the output differential system circuits (removal of DSO jumpers - Gn. per and Gn. pr in the circuit of Fig. 3.1) and by breaking relay R_2 circuit in the RTV block (removal of RO jumpers - manual operation).

Pulses pass practically undistorted through the high frequency channel. In the receiving part of equipment they are separated by the voice-frequency dialing-ringing receiver and also as the call signal are rectified in the PTNV circuit, acting after this on the polarized relay R_1 .

With armature oscillations in time with incoming pulses, the positive of the 24 volt battery ("ground") is applied through the right contact of the polarized relay, the key of Prov.PTNV, the closed contact of relay R_2 RTV, the jack Per add further to the entering set of voice-frequency dialing - VKTN which is present in the ATS equipment.

The entire SIO route introduces pulse distortions not over 6 nsec.

Constant current pulses which are sent from the polarized relay contacts can be applied by pressing the key Prov. PTNV through jack Prov. TN to any control device in order to check their form, determine their duration, etc.

If it is necessary to check the operation of UNCH-PTNV by way of applying this input a series of undistorted pulses, then one proceeds in the following way. The input

of UNCH is connected by cords with Prov.TV jacks which are located on the panel of speak-buzz device (PVU). Manipulating the dial disc and the corresponding PVU switches, a necessary number of 2100 c alternation current pulses can be applied with the required level to the UNCH-PTNV input. These pulses converted into sending of constant current can be observed by devices connected by the already mentioned jack Prov.TV.

All relays of the described circuit, except the relay R_2 of unit RIV, have an operation and drop out delay in the order of 75 to 120 msec, which prevents the sending of magneto ringing in the switching board direction with random operations of PTNV.

Structurally the RIV and RIV sets are made in the form of cut-in blocks. In one block type, four relay sets of magneto-ringing are contained, and in the other four voice-frequency ringing relay sets. Thus there are three blocks of each type on the SIO-12 rack, which occupy two 120 mm wide panels at the back of the rack. There are four such panels on SIO-24 rack.

3.8 Switching board and PVU

The SIO switch board is schematically illustrated on Fig. 3.13. It contains element groups relating separately to each channel and elements common to all channels.

The cut-in block of speak-buzz device PVU is a part of switchboard and it makes with it a single structural unit.

The control switching elements set of the channel (24 sets) consists of amplification regulator RU taken out on the bank from UNCH, 1 jack pair connected into two wire channel part (2 pr. lin and 2 pr. komm), one jack pair connected into transmission route (4 pr. lin and 4 pr. komm), one jack pair connected into reception route (4 pr. lin and 4 pr. komm), lamps recording the busy condition of the channel LZ and keys Kn Z by pressing of which the lamp LZ lights up, if the channel is indeed occupied by service personnel for checking purposes. Using jacks in two and four wire grounds a conversation can be conducted and a call can be sent with the aid of PVU in the switchboard direction and also into the line direction separately or at the same time. The same jacks

permit to make measurements and tests of the channels.

Twenty-four keys Prov. PTNV the purpose of which was already explained in section 7 of this chapter are placed separately at the bottom right of the board.

Lamps Pr. vyz and Pos. vyz serving for the control of generator (GTV) and voice-frequency ringing receiver (PTNV) operation, are located in the middle section of the switchboard. They are connected to this or that channel by pressing the corresponding keys Prov. PTNV.

Some switching board jacks - transition, connecting lines, service lines and others were introduced for different switchings and facilities with equipment operation.

The switching board of SIO rack is set up from jack spacers with jacks, keys and lamp holders, compactly made from plastic and metallic components. The application of such jack spacers permitted to reduce the switchboard dimensions, in spite of the large number of elements installed on it. The switching board is divided into two parts, each of which is fixed on hinges and can be folded back, providing access to elements from the assembly side.

Block PVU SIO performs a number of functions which make easier the servicing of the equipment and the control of its operation. PVU can be connected to a two wire and also to a four wire channel part, permitting with this a separate or simultaneous conversation in both directions from the place of connection. Communication is accomplished with the aid of PVU through the connecting and also through the service lines (including also the number dial with the connection to ATS). PVU is used when checking the voice-frequency dialing-ringing receiver, when controlling the load frequency amplifier and also with other checks, whereupon the amplification stage in the unit permits to raise the level of signals entering into the telephone.

With a four wire connection of PVU the above mentioned dividing jacks are used on the switching board 4 per lin, 4 per. komm and 4 pr. lin, 4 pr. komm, the signal level in which in correspondence with the level diagram equals -1.5 nepers (transmission) and $+0.5$

(reception).

Fig. 3.13. SIO switching board.

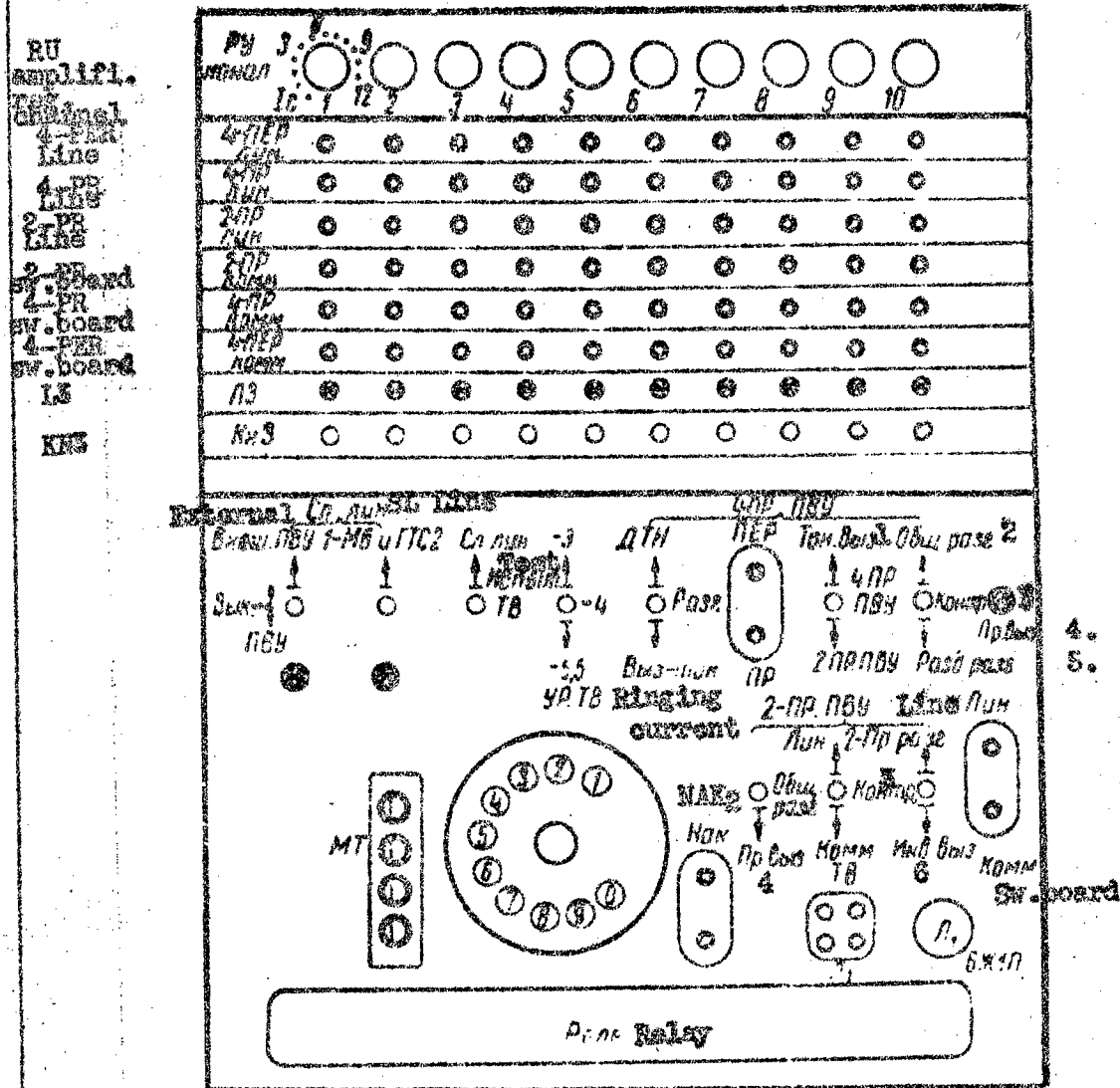

- 1. Voice frequency ringing
- 2. Common conversation
- 3. Control
- 4. 4PR Reception call
- 5. Separate conversation
- 6. Ind. call

Fig. 3.13. (Continuation)

RU amplif.		Py										
reg. channel		KONON J:										
4-PER		11	12	12	12	2	3	4	5	6	7	8
Line	4-PR	0	0	0	0	0	0	0	0	0	0	0
Line	2-PR	0	0	0	0	0	0	0	0	0	0	0
Line	2-PR	0	0	0	0	0	0	0	0	0	0	0
sw. board	4-PR	0	0	0	0	0	0	0	0	0	0	0
sw. board	4-PR	0	0	0	0	0	0	0	0	0	0	0
sw. board	4-PR	0	0	0	0	0	0	0	0	0	0	0
LS	AS	0	0	0	0	0	0	0	0	0	0	0
KNS	KH 3	0	0	0	0	0	0	0	0	0	0	0

RU amplif.		KONON J:				Depex 2H coded						PR		
reg. channel		Dc				reception call						Sending call		
4-PER		9	10	11	12	Line/ur								
Line	4-PR	0	0	0	0	0	0	0	0	0	0	0	0	0
Line	2-PR	0	0	0	0	0	0	0	0	0	0	0	0	0
Line	2-PR	0	0	0	0	0	0	0	0	0	0	0	0	0
sw. board	4-PR	0	0	0	0	0	0	0	0	0	0	0	0	0
sw. board	4-PR	0	0	0	0	0	0	0	0	0	0	0	0	0
sw. board	4-PR	0	0	0	0	0	0	0	0	0	0	0	0	0
LS	AS	0	0	0	0	0	0	0	0	0	0	0	0	0
KNS	KH 3	0	0	0	0	0	0	0	0	0	0	0	0	0
Prov.	PTNV	0	2	3	4	5	6	7	8	9	10	0	0	0
PTNV	PTNV	11	12	1	2	3	4	5	6	7	8	0	0	0
PTNV	PTNV	9	10	11	12	0	0	0	0	0	0	0	0	0

On Fig. 3.14 a part of the PVU circuit is illustrated, made from its elements in the case of four wire connection.

Fig. 3.14 PVU circuit with 4-wire connection.

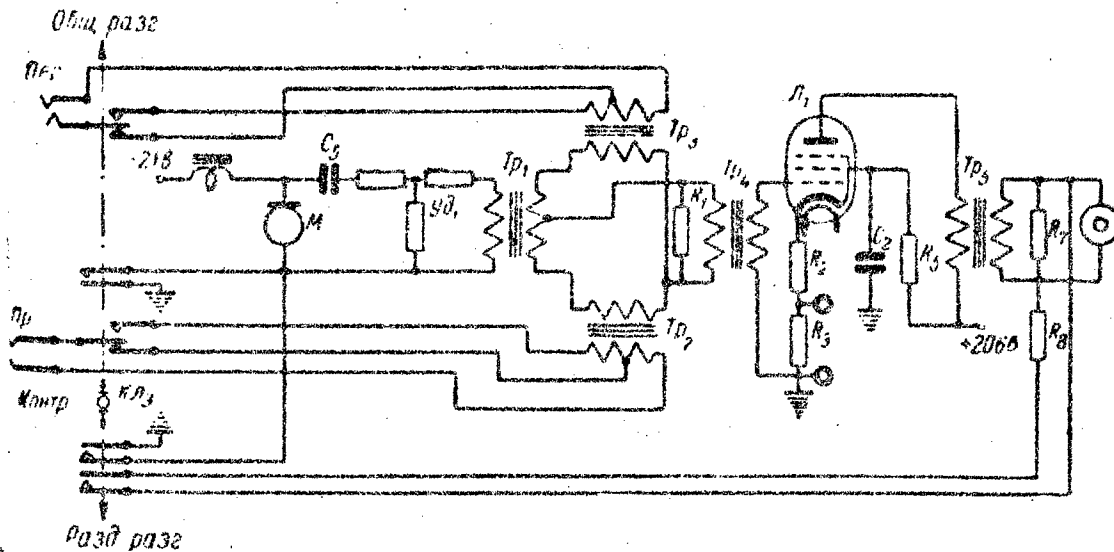

Transformer Tr_1 forms a nonequal branch differential system. Attenuation from microphone M to jacks Per is higher by two nepers than from the microphone to jacks Pr , which provides the necessary level values, when speech is made from PVU in the line direction and in the switching board direction.

Cross talk attenuation between transformers Tr_2 and Tr_3 is 4.5 nepers. These transformers permit to obtain input resistance values in the PVU direction equal to 600 ohms with separate conversation and 5000 ohms with common (simultaneous) conversation. To accomplish this or the other form of conversation was possible as a consequence of special soldering system of separating jacks in the switching board (common conversation and control are possible only with jacks connected in the switching board direction).

For the attenuation compensation introduced by the differential transformer from jacks $Peredacha$ in the telephone T direction, an amplifier is provided consisting from a tube L_1 , input transformer Tr_4 , output transformer Tr_5 and two load resistors R_7 and R_8 . The latter is connected only with separate conversation, when

the signal level entering the telephone increases. As a result the telephone level is always of the order -1 neper

A voice-frequency ringing can be sent from FVU in the line direction, a constant current call in the switching board direction and a call from the switching board can be received (these circuits are not shown on Fig. 3.14 for the simplicity of the schematic).

With two wire connections of FVU a circuit is formed illustrated on Fig. 3.15 as the previous circuit, it permits to accomplish a separate and common conversation from jacks 2 pr. lin and 2 pr. komm, to send a call in the switching board direction and to receive a call from the line and also from the switching board. For this the circuit has rectifier bridge M, relay R₁ and signal lamp L₁.

Fig. 3.15 PVU circuit with 2-wire connection.

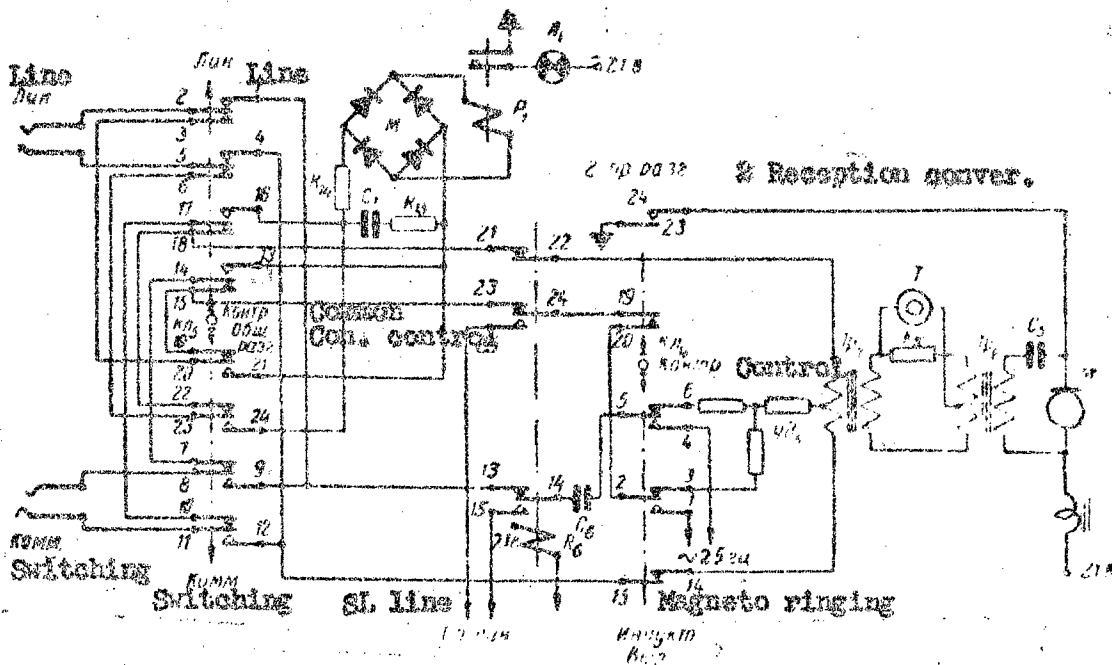

Approximately the same two wire circuit is made, when it is necessary to carry a conversation from any of the two service lines.

3.9 Neper meter

The neper meter serves to measure the overall

channel attenuation and also control the level in the frequency range from 300 to 3400 c. Generator and level recorder are included in the neper meter constitution (Fig. 3.16).

The generator is a two stage RC coupled amplifier with tubes L_1 and L_3 of the type 6ZH1P-E, having positive and negative feedback circuits. The positive feedback circuit consists of 2 ULI type resistors (R_1 and R_9) and 9 pairs of type SSG-1 capacitors (C_1 and C_2).

The setting of generated frequency is accomplished by a switch, having 9 positions corresponding to fixed frequencies 300, 400, 600, 800, 1600, 2100, 2400, 3000 and 3400 c. This switch connects different capacitances into the circuit conditionally represented on Fig. 3.16 by capacitors C_1 and C_2 .

Fig. 3.16. Neper meter circuits

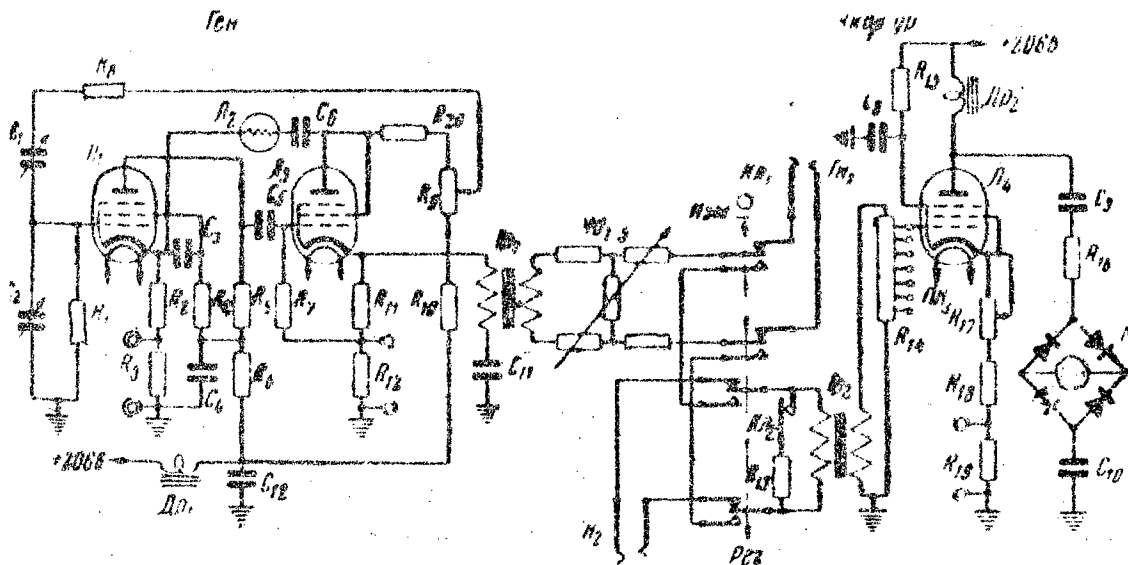

The positive feedback circuit voltage is taken off the potentiometer R_9 which is part of the tube L_3 plate load. The generator output level can be varied within a small range (0.1 neper) at the expense of the potentiometer resistance variation, i.e. at the expense of positive feedback circuit variation.

With the presence of negative feedback, the circuit of which is formed by thermistor L_2 and resistors

R_2 and R_3 , the level in certain ranges does not depend on voltage oscillations of power supplies.

The generator has a cathode output. The output transformer Tr_1 is designed in such a way that the generator output impedance $Z_{out} = 600$ ohms. The level at the output is regulated by a two way switch which commutates the H-shaped attenuators Ud_{1-5} . With the connection of attenuators the output level = + 0.5 nepers. With the introduction of attenuators Ud_5 , Ud_4 , Ud_3 , Ud_2 and Ud_1 , the level correspondingly decreases to 0, -0.4, -0.7, -1.5 and -2.0 nepers.

Generator output circuits are wound on the switch Kl_1 contacts after the attenuator and then are terminated by Gn_1 jacks. The generator output is connected with the level indicator input by the key Kl_1 . Besides this, the output level value is checked with different two way switch positions.

If the generator level somewhat changes when the tubes and thermistor are replaced, then it can be restored by the potentiometer R_9 .

The level indicator can measure levels at the range -4 nepers to +3 nepers. It consists of input device (R_{13} , Tr_2 , R_{14}), one amplifier stage with tube L_4 (6ZH1P-E), a rectifier device and constant current (ma) indicating device which is calibrated in nepers. The level indicator input is let out to the Gn_2 jack. Besides this, at the level indicator input are found the key Kl_2 by which the 600 ohm and r resistance input impedance of the device can be established, and the voltage divider R_{14} with two way switch PK_3 serving to establish the required indicator level sensitivity + 3, +2, +1, 0, -1, -2, -3 nepers. The measurement error at frequency 800 c at the 0 neper mark is not over ± 0.05 nepers.

The detector device (M) is made by a full wave rectifier circuit with germanium diodes D2B; micro-ammeter M-24 for 10 μ a with the first class is used as the indicating device.

Resistance R_{16} is connected in series with the bridge for temperature compensation of diode resistance variation.

3.10 Test amplifier

The test amplifier (IUs) is intended to check the channels of individual equipment "on itself" by connecting it between transmission and reception routes.

The amplifier circuit (Fig. 3.17) has two stages with tubes 6ZH1P-E and with negative feedback, the depth of which is 3.4 nepers. The feedback voltage is taken off part of the transformer Tr_2 secondary winding through elements C_5 , R_7 and applied into the cathode circuit of the first tube.

Fig. 3.17 Circuit of test amplifier IUs.

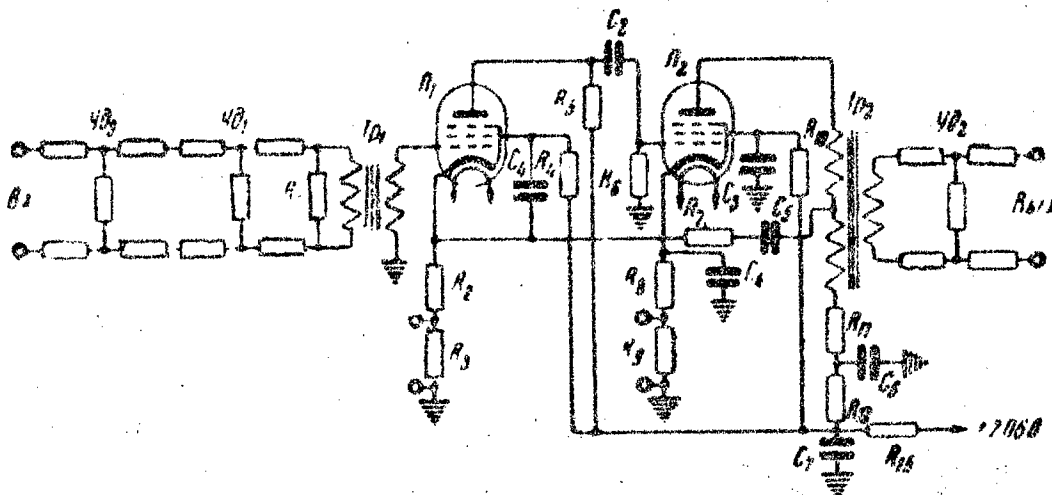

The amplifier amplification in the operating frequency band 60-108 kc = 3.2 nepers, and the non-uniformity of frequency characteristic is not over 0.03 nepers. The amplitude characteristic is a straight line up to the output level value +2 nepers. Nominal values of input and output impedances = 600 ohms.

For a better amplifier matching with loads, the attenuators Ud_1 ($b = 0.5$ nepers), Ud_3 ($b = 1$ neper) are connected at its input and attenuator Ud_2 ($b = 0.5$ nepers) is connected at its output.

The amplifier is connected to the tested channel between the output of transmission route channel filter and the input of reception route channel filter of SIO. The measurement levels at these points have the values -4.2 and -1 nepers correspondingly. It can be also used to check the entire equipment SIO "on itself" to which are

also subject the group elements of this rack (Fig. 3.1).

It is necessary to use line transformers in this case to match the amplifier input and output with the SIO transmission and reception routes output and input (having resistance of 135 ohms). Similar transformers are used for example in the measurement bench IP-150. With complete check of SIO, amplification of IUs should be increased to 1 neper for which the attenuator Ud3 is disconnected.

Chapter 4. Group equipment

4.1 General information

Group equipment is intended for conversion and amplification of currents incoming from the individual part of equipment (SIO) with frequency spectrum 60 - 108 kc into linear frequency spectrum 36 - 84 kc or 92 - 143 kc, and for inverse conversion of currents incoming from the line into the frequency spectrum 60 - 108 kc.

Group equipment is combined into one rack (SGO) with generator devices, to supply the group and individual converters by carrier currents, and with automatic level regulation devices.

Depending on the transmission direction A-B or B-A and on the linear spectrum alternate I, II, III, or IV (Fig. 1.1), SGO has two principle forms: SGO-A and SGO-B (their construction difference is shown on Fig. 2.1). In the SGO-A rack, the upper frequency group 92 - 143 kc is transmitted into the line and the lower 36 - 84 kc is received, and in the rack SGO-B, the lower frequency group is transmitted into the line and the upper is received.

Units entering into the group equipment can be subdivided into two groups.

To the first group are related units which are common to the terminal and also to the tandem offices. To them relate: linear amplifiers (high frequency LUs. or low frequency LUs.), directing filters (DK-88), linear filters (DK-33), regulating artificial lines (RIL), matching device (SU), devices for distant power transmission to satellite repeater office VUS-12 (DDP and PDP), additional filters (D-88 dop or K-88 dop) and low-pass

filter (D-153).

To the second group refer units used only in group equipment of the terminal office: band elimination filters (ZF-A or ZF-B), transmission route group converters of frequency (GP-1 and GP-2) and reception route group converters of frequency (GP-1 and GP-2), group band filter (GPF), transmission amplifier (Us. per), low-pass filter (D-200), transmission route rectifier (Vyr. per) and reception route rectifier (Vyr. pr), low pass filter (K-77), additional filter (K-22) for the SGO-A rack and reception amplifier (Us. pr).

Principle information which characterizes the group equipment routes is the following: the transmission measurement level at the line output = + 2 nepers, at the transmission route input -4.8 nepers and at the reception route output -0.6 nepers.

The frequency characteristic of transmission route maintains its straight line feature with an accuracy of 0.1 nepers, and that of the reception route with different positions of regulators RIL with an accuracy of ± 0.07 nepers.

The maximum amplification of reception routes for racks SGO-A and SGO-B is by 2.6 nepers lower than the amplification of the corresponding routes of the tandem office PV-12-2. The transmission and reception amplitude characteristic maintains its straight line with an accuracy 0.03 nepers with the increase of the output level by 2 nepers relative to the nominal value.

The nominal value of input resistance from the side of matching devices SU connection equals 600 ohms.

The reflection coefficient at this point with respect to the 600 ohm resistance is not over 10%. The nominal value of input and output resistance from the SIO connection side = 135 ohms.

Below in sections 2, 3, 4 and 5, units are examined which are common for terminal and tandem offices, and in sections 6, 7, 8 and 9, the units which enter into the constitution of group equipment only for terminal offices.

4.2 Linear amplifier

Linear amplifiers (LUs) are intended to amplify

frequency spectrum currents and to produce a transmission level equal to +2 nepers at the office output.

Two types of linear amplifiers are used in V-12-2 equipment. The lower frequency group amplifier connected into the transmission route of the terminal office B and into the route B-A of the tandem office, and the upper group frequency amplifier connected into the transmission route of terminal office A and into the route A-B of the tandem office. They differ only by input transformers and resistance values connected in the secondary windings of these transformers.

The linear amplifier (Fig. 4.1) has three amplifier stages. In the first two, the tubes 6ZH1P-E are used, and the third contains three parallel connected tubes 6P3S-E. The application of these tubes permitted to produce undistorted power at the amplifier output over 6 watts (up to + 4.5 nepers).

The amplifier circuit is provided by a deep combined negative feedback which encompasses all stages and the output transformer Tr_2 .

The feedback voltage is applied from the output transformer through resistors R_{26} and R_{27} into the cathode circuit of the first tube (R_2). The feedback circuit is constructed in such a way that the amplifier output impedance which is = to 135 ohms is basically determined by the resistance R_{26} value. Its variation in known range practically has a little influence on the feedback, and consequently, on the amplifier amplification. At this same time, by varying the value of resistance R_2 , the amplifier amplification can be regulated; its output impedance with this practically remains constant.

Almost the whole value of negative feedback depends on the external feedback which encompasses all the stages, and only a negligible value in the order 0.4 nepers is on the local feedback, which encompasses the amplifier output stage.

The amplifier amplification value without the feedback is 11 nepers, and with the feedback it is 6.2 nepers. The frequency characteristic nonuniformity in the operation frequency band is not over 0.03 nepers. A circuit R_8, C_5 which lowers the amplification in low

Fig. 4.1 Linear amplifier circuit.

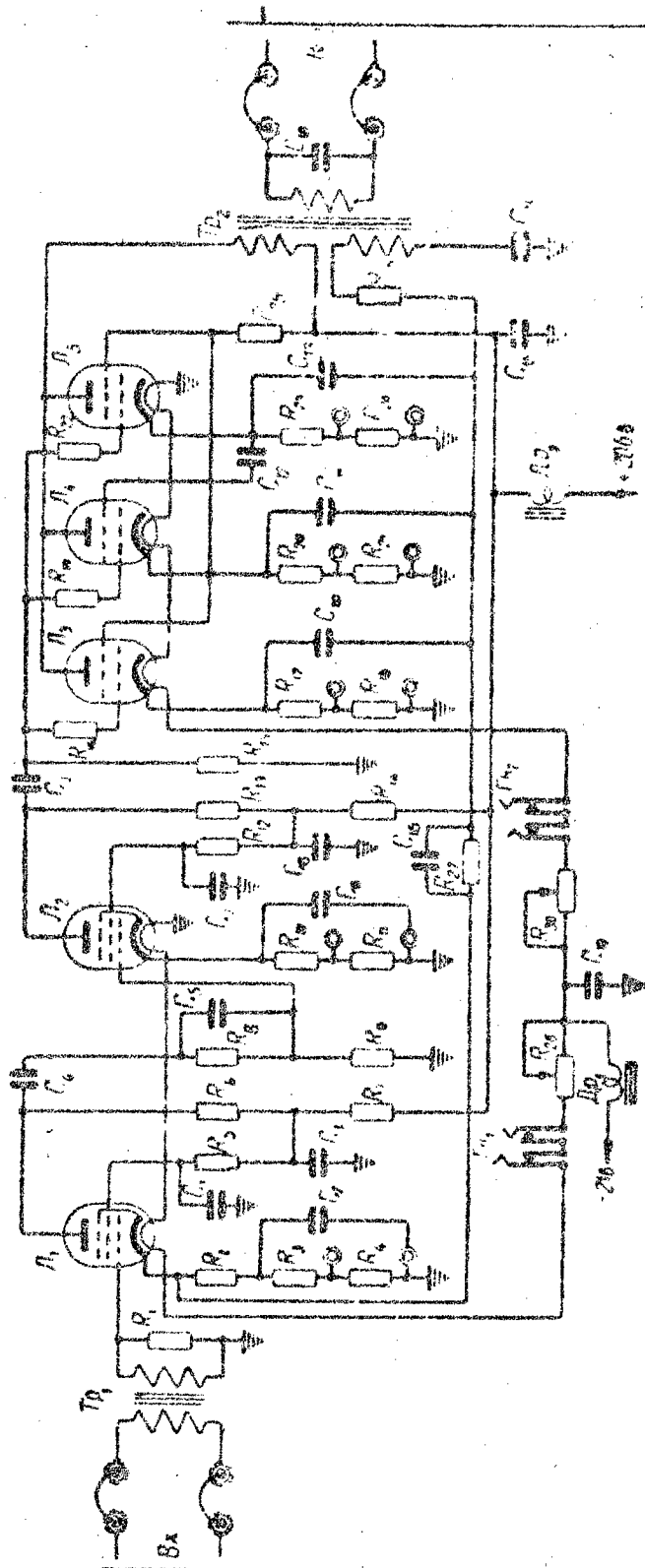

frequency range and circuit R₂₇ C₁₆ which lowers the amplification in high frequency range are provided for amplifier stability.

To eliminate mutual effect of amplifiers through power supplies, the coupling filters are placed in the feeding circuits of each amplifier: filter Dr₂ C₁₅ in the common plate circuit and filter Dr₁ C₁₇ in the heater circuit.

Nominal value of amplifier input and output impedances is 135 ohms. With this the amplifier reflection coefficient with respect to 135 ohm resistance is not over 15% from the input side and 5% from the output side.

Nonlinearity attenuation of the amplifier with output level + 2 nepers is not less than 8.5 nepers by the second harmonic and not less than 10 nepers by the third harmonic.

High quality indices of the linear amplifier are very stable in time. This is attained by the application of deep negative feedback in the examined circuit, that encompasses all stages, by the adopted measures of stability increasing and also by the selection of relieved conditions for the output stage.

4.3 Filters

Directing filters DK-88 are intended to separate the transmission directions, i.e. to separate the linear spectrum of the 12 channel system into lower 36 - 84 kc and upper 92 - 143 kc frequency groups. Each directing filter set consists of low pass filter D-88 and high pass filter K-88 connected in parallel (Fig. 4.2). Both filters are made by an unbalanced circuit.

A directing circuit L_g C₁₇ is connected from the parallel filter operation side and it increases the filter attenuation in the difiltration band (84 to 92 kc) and also provides better matching conditions of the filter input resistance with loads.

Nominal value of filter input impedance = 135 ohms. The reflection coefficient between the filter input impedance and the 135 ohm resistance is not over 10%.

Linear filters DK-33 divide the linear spectrum of 12 and 3 channel systems operating on one circuit.

Fig. 4.2 Circuit and characteristics of DK-88 filters.

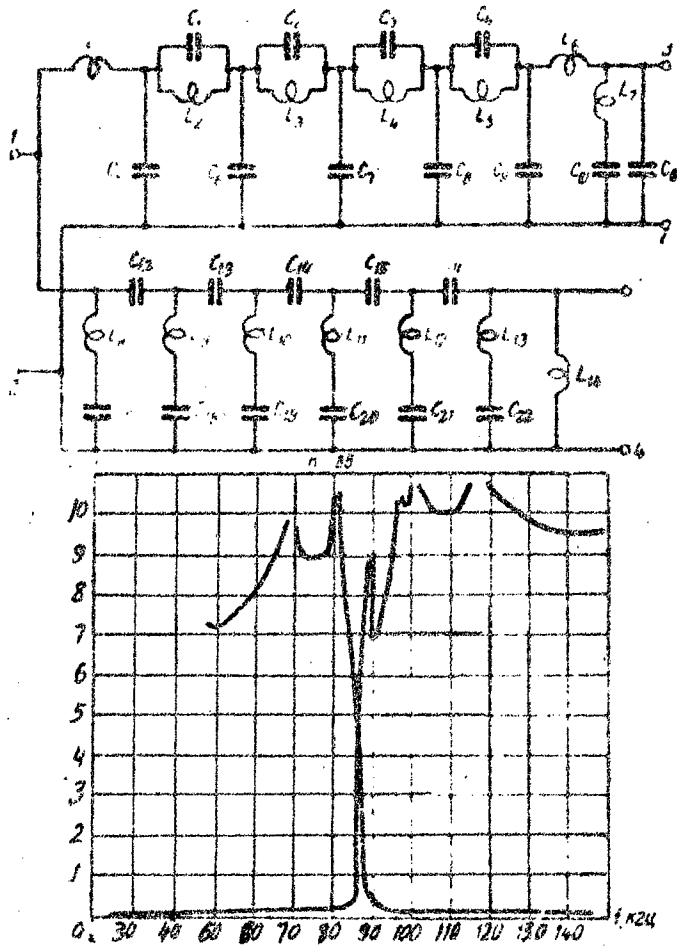

Each set of the stated filters consists of low pass filter D-33 and high pass filter K-33. The principle circuits and frequency characteristics of these filters are illustrated in Fig. 4.3. These filters are made with balanced circuit, in so far as they are connected to the

aerial line which requires load symmetry relative to ground.

Asymmetrical attenuation of these filters $A_U = \ln \frac{U_n}{\Delta U}$ is not smaller than 5 nepers in the operating frequency band, here U_n - voltage measured on the filter load resistance; ΔU - voltage measured between the mid-point of load resistance and ground (frame).

The correcting circuit $L_8 C_7 C_8$, which improves filter matching with load and increases attenuation in the defiltration band, is connected from the parallel filter operation side.

Nominal value of filter input impedances = 600 ohms. Between filter K-33 and the directing filter DK-88, the line transformer Tr_1 is connected, which matches the input impedances of these filters (600 and 135 ohms).

In the terminal and also in the tandem offices, linear and directing filters are connected from the side of their parallel operation to those route places, where the currents of both transmission directions pass, whereupon currents of one direction pass with high level and currents of other direction with low level. This circumstance requires a high degree of linearity from filters and consequently from the elements which make up these filters. Otherwise, the harmonic components and combined currents would introduce considerable mutual interferences into the channels.

Therefore, the filter inductors do not have ferro-magnetic cores, and capacitor bodies, filter shields and brackets inside the shields are made from red copper.

Linear and directing filters are structurally analogous and represent two hermetically sealed seven section tanks. Circuits are placed inside them, made of especially stable capacitors SSG and inductors on plastic frames.

External view of filter tank and one standard section is shown on Fig. 4.4.

When making calculations it should be considered that filter D-33 sometimes operate in somewhat more complicated conditions than other filters. With the connection of satellite repeater offices (VUS-12), a

constant current of distant source flows through the filter elements. However, this current does not introduce additional distortions into frequency routes.

Fig. 4.3 Circuit and characteristics of DK-33 filters.

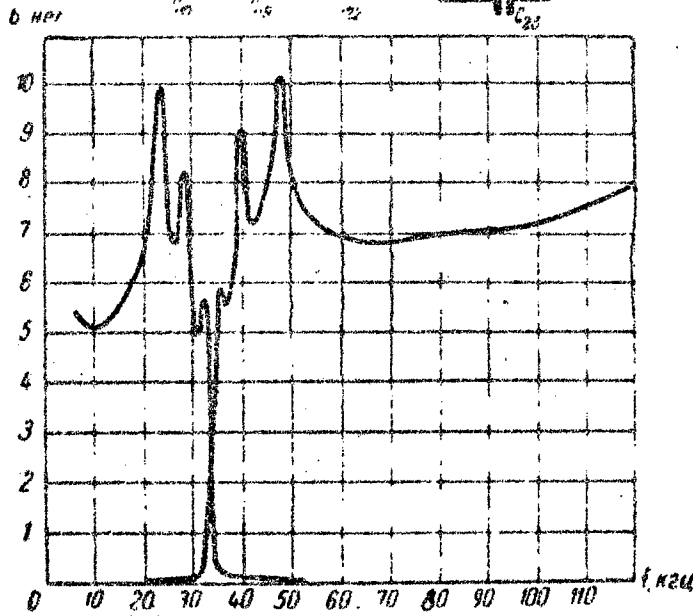
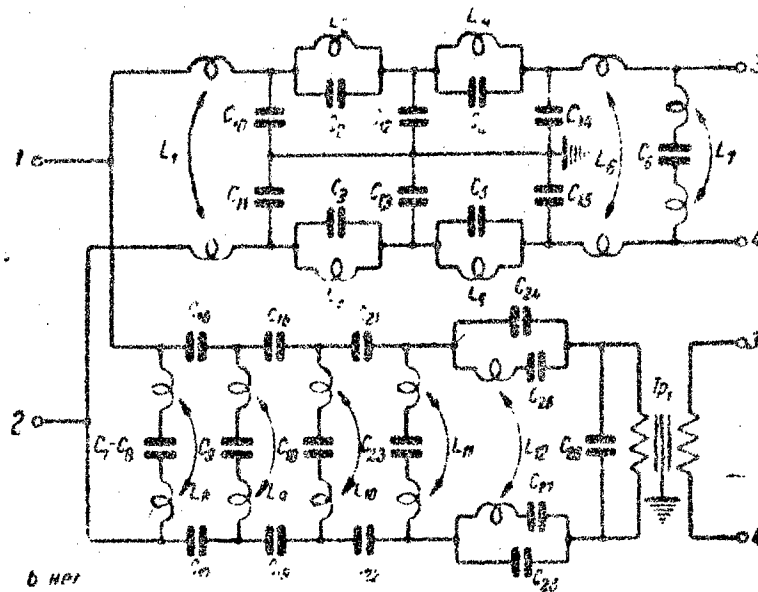

Additional filters D-88 dop and K-88 dop amplify the effect of principle directing filters DK-88 in the attenuation band, providing by this the necessary attenuation for reverse direction currents (loop attenuation). These filters are connected into group routes at low level points, therefore no high requirements on non-linearity attenuation are presented to the elements of these filters.

The principle circuit and frequency characteristic of attenuation for filter D-88 dop are shown in Fig. 4.5 and for filter K-88 dop on Fig. 4.6. It is seen from the circuits that each filter consists of two m type sections. Inductors with carbonyl iron cores and mica capacitors are used as the filter elements.

Fig. 4.4 External view of the filter tank.

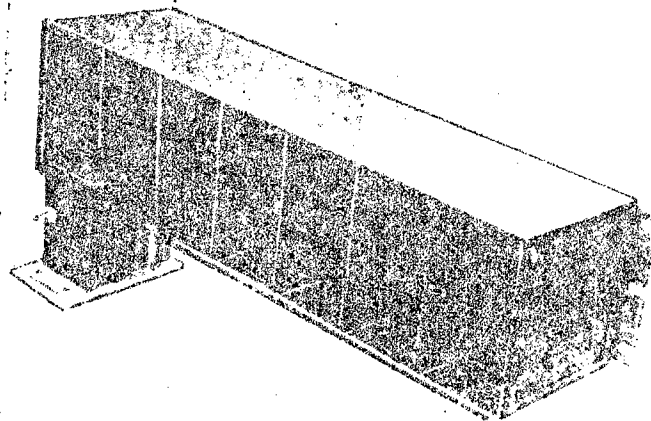

Low pass filter D-153 is intended for the protection of the group route of the upper frequency group from interferences created by broadcasting stations operating in frequency range from 160 kc and higher. This filter is connected into the upper frequency group route at the regulating artificial line input, i.e., in direct proximity to the linear equipment input. The

circuit and the filter attenuation characteristic are illustrated in Fig. 4.7.

Fig. 4.5 Circuit and characteristics of D-88 dop filter.

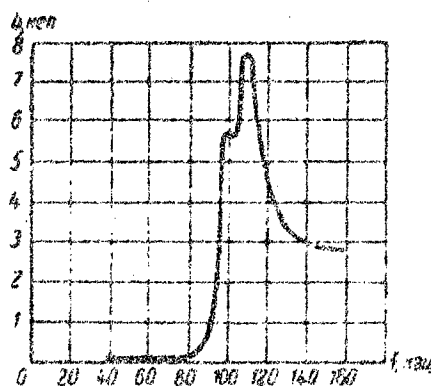
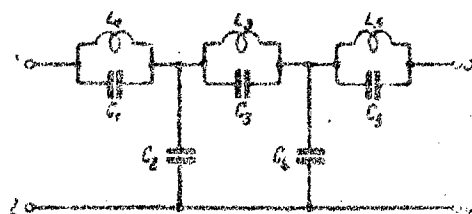

Filter D-153 is accomplished by an unbalanced circuit. Its attenuation in the pass band up to 143 kc is not over 0.03 nepers, while in the attenuation band (from 162 kc and higher) it has an attenuation not smaller than 6.4 nepers. Nominal value of filter input impedances = 135 ohms. The reflection coefficient between input and 135 ohm resistance is not over 8% in the operation frequency band.

Type SGMZ mica capacitors and inductors with sheath carbonyl cores SV-4a are the filter elements.

Structurally the filters are made in the form of hermetically sealed blocks. All filter components are mounted on a chassis, which is placed into a housing with

glass partition insulators. Structural information of type SB cores is given in Fig. 4.8. As seen from the figure, the SB core consists of a cup with thread 1, a smooth cup 2, and fine adjuster 3.

Fig. 4.6 Circuit and characteristic of K-88 dop filter.

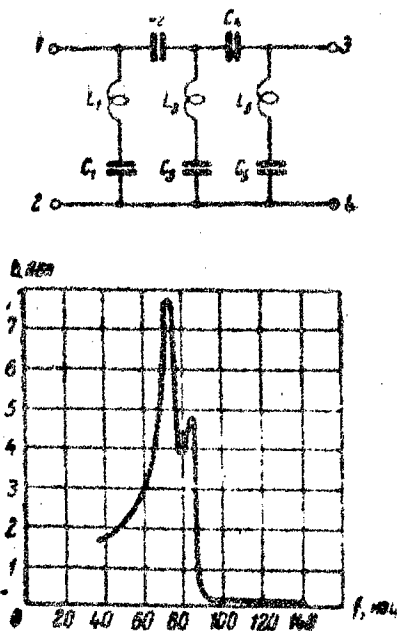

Because of the small nonlinearity the filter coils prevent the appearance of nonlinear distortions with favorable meteorological conditions, when the attenuation of the preceding amplifier section is small and large level currents enter the filter input.

Fig. 4.7 Circuit and characteristic of D-153 filter.

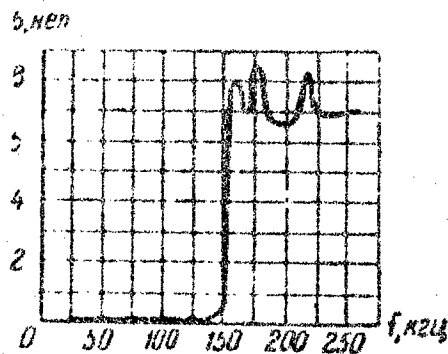
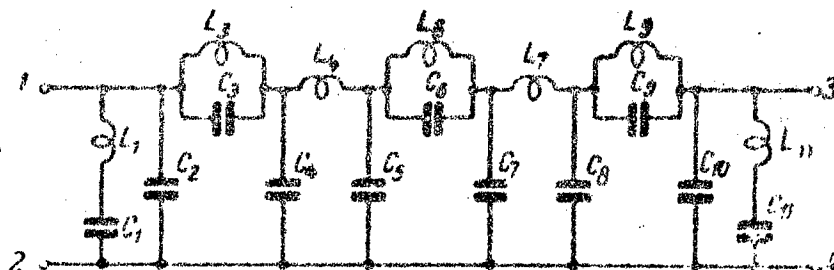

4.4 Matching devices and devices for transmitting distance supply.

The matching device SU is intended for the matching of equipment input impedance with the impedance of line connected to it.

Cables with paper cordal or styroreflection insulation are used in most cases for leading in the line to the terminal and tandem offices. Aerial or coil loaded inlets are used less frequently. Depending on the type of inlet cables, having different wave impedances, three forms of matching devices are provided: 1) auto-transformer with load impedance ratio 550:140 and conductor diameter 1.4 mm for cable with cordal paper insulation; 2) auto-transformer with load impedance ratio 550:180 and conductor diameter 1.4 mm for cable with styroreflection insulation; 3) coil loading office set KPS for coil loaded cable with styroreflection insulation, conductor diameter 1.2 mm and load-coil spacing 120 m.

Fig. 4.8 Structure information of SB-2a and SB-4a cores.

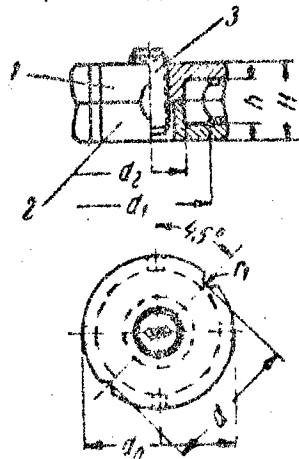

Type of core	Dimensions, mm						
	d_0	d_1	d_2	d	H	h	r
SB-2a	25	26	10	21	11	6.2	1
SB-4a	28	22	13	26	23	17	1

Each matching device has resistors which establish the output impedance value of equipment in the range from 550 ohms to 600 ohms. These resistances are connected in parallel at the office output of the matching device.

Devices for distance power supply transmission to satellite repeater stations VUS-12 are provided on the group equipment racks of the terminal and tandem offices. These devices consist of distance power supply yokes DDP through which distance power supply current is applied to linear filters D-33 and further into the line, and transmission panels of distance power supply FDP, on which the following switching is accomplished: the distance power supply voltage is switched on and off, distance power supply current is regulated by variable resistance, distance feeding current and voltage are controlled by indicating instrument, telephone transit relay is switched on with the absence of distance

feeding, signalization is switched on when the distance feeding current value is over the standard specification.

With the aid of the examined devices, separate feeding is accomplished for amplifiers of both directions in equipment VUS-12 by the circuit wire-ground. Nominal current value of amplifier feeding for each direction = 180 ma. Nominal voltage value of distance feeding at the input of PDP device = 206 v.

Operation of all elements of the distance supply feeding device can be traced in the circuit illustrated on Fig. 4.9.

The supply is switched on by key Kl_1 or the key Kl_2 depending into which circuit wire the distance supply has to be connected. By turning it on, e.g. into wire a, the key Kl_1 should be first placed in the center position (-21), and then in the upper (+206). When the key is put in the center position the differential relay DR_a operates (from the current flowing through compensation winding 1-2) and also the auxiliary connection relay RVV_a . Besides that, relay R_1 operates in DDP, which by its contact 13-14 prepares the circuit for distance supply feeding to filters DK-33 and by contacts 11-12 takes off the shunt from separation capacitor $C_1 = 10 \mu f$ which prevents the distance feeding current from getting into the equipment.

When differential relay DR_a operates, the signal lamp L_1 lights up and circuit is created for signalling operation on row transparency.

Signalling operating continues until the key Kl_1 will not be switched over to the upper position, after which distance feeding current through choke Dr_1 winding 1-8 and filter D-33 enters the line. A circuit is made for distance supply feeding by wire b through the second half winding separated from the first by capacitor $C_3 = 10 \mu f$.

Attenuation introduced by choke at frequencies 0.3 to 36 kc is not over 0.05 nepers.

Simultaneously with placing the switch Kl_1 to the upper position, the key Kn_1 should be pressed to exclude the possibility of supply switching off relay RVP_a operation. This latter can remove distance feeding from the line with momentary operation of relay DR_a from the

Fig. 4.9

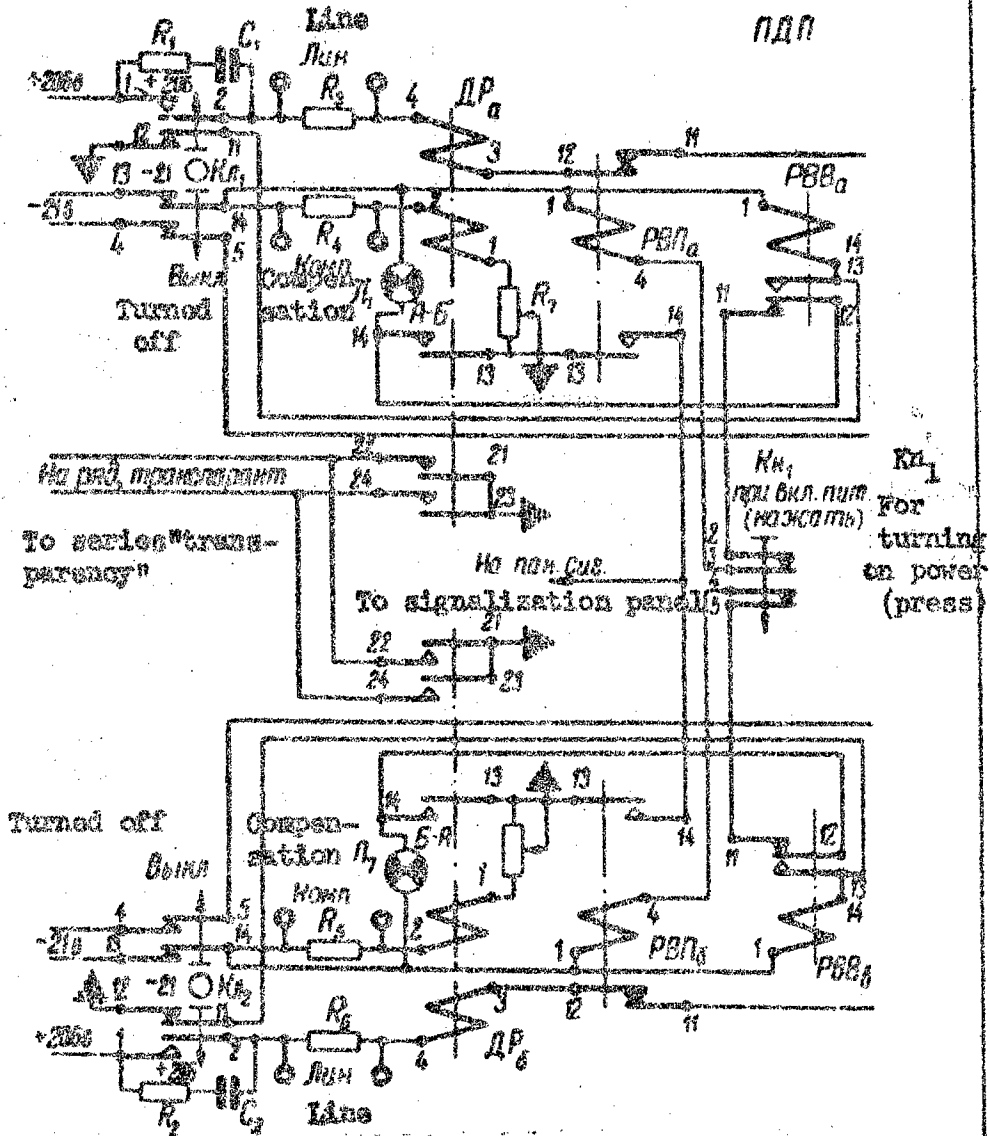
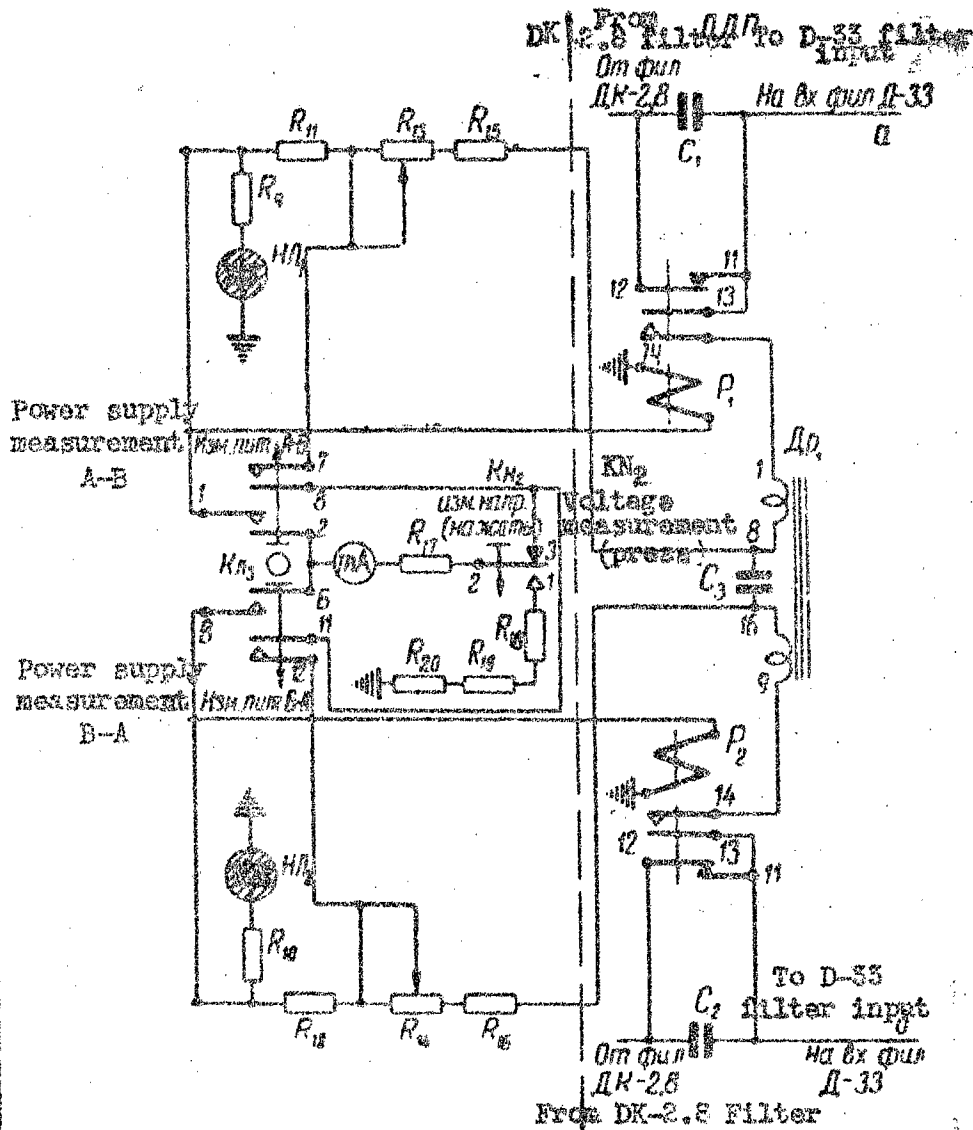

Fig. 4.9 (Continuation).



increased current which flows in the line winding in the run-up period of tubes in VUS-12.

For normal operation of distance feeding devices operation, the currents in the line and compensation windings of relay DR_a are adjusted to be the same = to 180 ma. As a result of this, relays DR_a and RVP_a are in a nonoperating condition, which is marked by the burning of neon lamp NL_1 which indicates the good condition of distance feeding circuit.

Current measurement in relay DR_a windings is made by PIEL device at the jacks which have corresponding inscriptions Lin and Komp. Besides that, there is a device mA on the distance supply feeding panel which measures current and voltage of distance feeding.

Connection of the device to this or the other circuit is made by the switch $K1_3$ the shunt in the device is designed to measure currents up to 300 ma. When voltage is measured, the key Kn_2 is pressed, which connects resistances in series with the device, which extend the measurement range up to 300 v. When the distance feeding current changes by more than 30% relative to the nominal value, relays DR_a and RVP_a operate, the distance feeding circuit is open, neon lamp NL_1 goes out and circuit is made for signalling operation on the transparency.

Analogously, the passing of current in different circuits with supply feeding through wire b can be traced on the circuit of Fig. 4.9. Relays with subscript b operate in these circuits.

4.5 Initial slope equalizers

Initial slope equalizers, Vyr. nach. nakl. nch and Vyr. nach. nakl. vch, are introduced into the reception route of racks SGO-A and SGO-B and into the corresponding routes of the tandem office for simplifying the principle equalizer circuits of the regulating artificial line RIL and for decreasing group equipment set noises at low frequencies in the operation range.

Principle circuit and frequency characteristic of equalizer Vyr. nach. nakl. nch are illustrated on Fig. 4.10, and of equalizer Vyr. nach. nakl. vch on Fig. 4.11.

Fig. 4.10 Circuit and characteristic of low-frequency initial slope equalizer

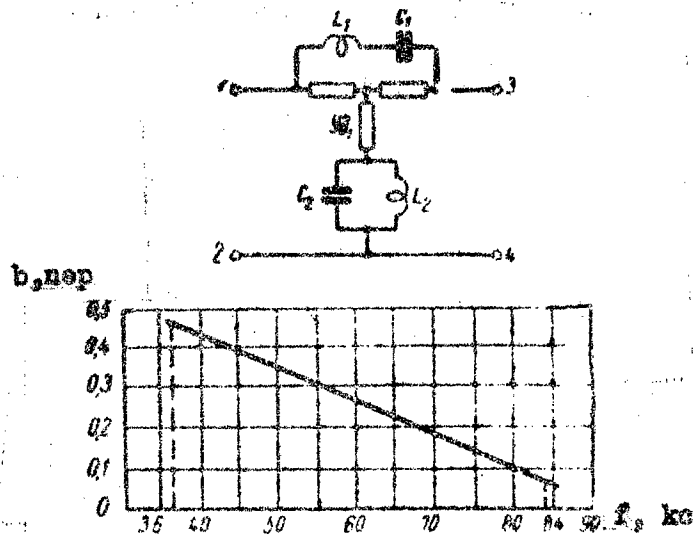
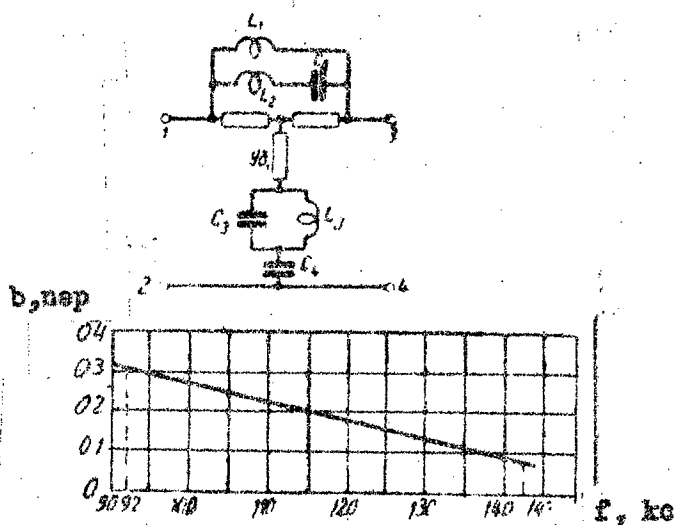

Fig. 4.11 Circuit and characteristic of h-f initial slope equalizer.



It is seen from the figures that both equalizers are made with unbalanced circuits and their characteristics in operation frequency band have a straight line sloping character. The characteristic slope of equalizer Vyr. nach nakl. nch is $b_{36} - b_{84} = 0.5$ nepers, and of equalizer Vyr. nach. nakl. vch is $b_{92} - b_{143} = 0.3$ nepers.

At upper frequencies of operating range the equalizer attenuation is not over 0.05 nepers.

Inductors with cores SB-2_a and SB-4_a and mica capacitors SSG and SCMZ are the equalizer elements.

With equipment operation on the main line, containing short amplifying sections, the equalizers can be switched off.

4.6 Group frequency converters

Ring circuit converters (Fig. 4.12) are used in the two stages of frequency group conversion in transmission and reception routes.

An advantage of the ring converter circuit over others is the production of the smallest number of spurious conversion products. This circuit property is very important for group converters, since the elimination of these products from the operation spectrum aids the increase of mutual protection between channels, excludes group route amplifier overload and finally eliminates the appearance of transient currents with different frequency combinations on the parallel circuits.

Fig. 4.12 Group frequency converter circuit

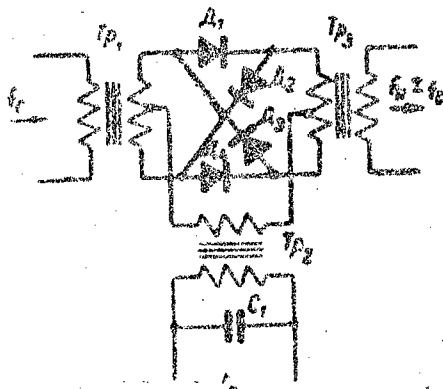

The necessary relation is also selected between voltages of modulating (U_s) and carrier signals (U_n) on the diodes, to provide a complete guarantee from the appearance of these undesirable effects in group converters. The quantity $\frac{U_s}{U_n}$ approaches values in the order

0.007 to 0.005, which leads to negligible amplitudes of parasitic oscillations. A good converter balancing which is obtained by careful diode selection serves the same purposes. By upsetting the balance at the output of this unit, and consequently at the office output, a number of new composite conversion products appear, which are not inherent in the ideal ring circuit.

Besides four nonlinear elements (diodes), the converter contains also three transformers. Two of them, input and output (Tr_1 and Tr_3), have mid points in one of the winding through which carrier frequency current is applied. The third transformer (Tr_2) connected from the side of carrier frequency current feeding, matches the converter with group carrier frequency amplifier output. Germanium diodes D2B are used as a nonlinear element.

An exception is the second group converter in the transmission route with connected copper oxide rectifiers MKV-7-1, with the presence of which the output spectrum contains the smallest number of spurious conversion products.

The input signal level P_s and carrier frequency voltage U_n should correspond the datum given in table 4.1 on the corresponding input terminals of the converter.

The converter attenuation = 1 neper. The carrier current level at the output of any group converter is not over -4.0 nepers.

Converter	P_s , nep	U_n , v
GP-1 per	-4.9	2.5
GP-2 per	-2.6	2.1
GP-1 pr	-4.1	2.5
GP-2 pr	-5.0	2.5

Table 1

The group converters GP-2 per have a somewhat different circuit from that illustrated on Fig. 4.12. Its input transformer is a differential one, whereupon currents of spectrum 60 to 108 kc are applied to one input, and control frequency currents to the other.

4.7 Transmission amplifier

The transmission amplifier $U_{g\text{ per}}$ is connected into the transmission route after the group band filter GPF and is intended for amplification of currents with frequencies 394 to 451 kc, obtained after the first group conversion of frequency.

The amplifier (Fig. 4.13) has two amplifier stages with tubes L_1 and L_2 (type 6ZH1P-E). Transformer Tr_1 is on the amplifier input and transformer Tr_2 is at the output, which contain ferrocarr cores and together with loads $R_1 C_1$ and $R_{15} C_9$ specify the input and output amplifier impedance = 135 ohms.

Fig. 4.13 Transmission amplifier circuit

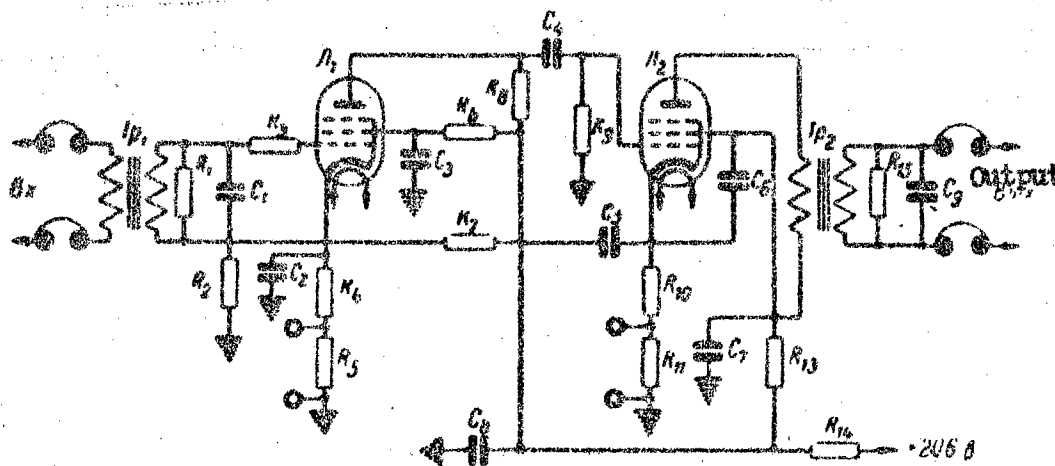

Negative current feedback with a depth 2.1 nepers is provided in the amplifier circuit, which is applied from the tube L_2 cathode circuit (resistors $R_{10} - R_{11}$) to the amplifier input (resistance R_2). Amplification of this amplifier in operation frequency band equals 3.7 nepers. Nominal value of output level is -2.5 nepers. The amplifier amplitude characteristic maintains its straight line up to the output level value of 0 nepers.

4.8 Reception amplifier

Reception amplifier $U_{s\text{ pr}}$ is connected at the output of group reception route and serves for the amplification of currents with frequency spectrum 60 - 108 kc, separated by D-200 filter after the reception

frequency converter GP-2 pr.

The amplifier circuit (Fig. 4.14) has two tubes L_1 and L_2 (Type 6ZH1P-E). There is a two winding transformer Tr_1 at the input of the amplifier and a differential transformer Tr_2 at the output. To one input of the latter the reception route of the individual equipment rack is connected, to the other - the control channel receiver. A combined negative feedback with depth 2.5 nepers is used in the receiver, which is applied from winding II of transformer Tr_2 and resistance R_{12} to resistance R_2 inserted into the cathode circuit of tube L_1 .

Fig. 4.14 Reception amplifier circuit

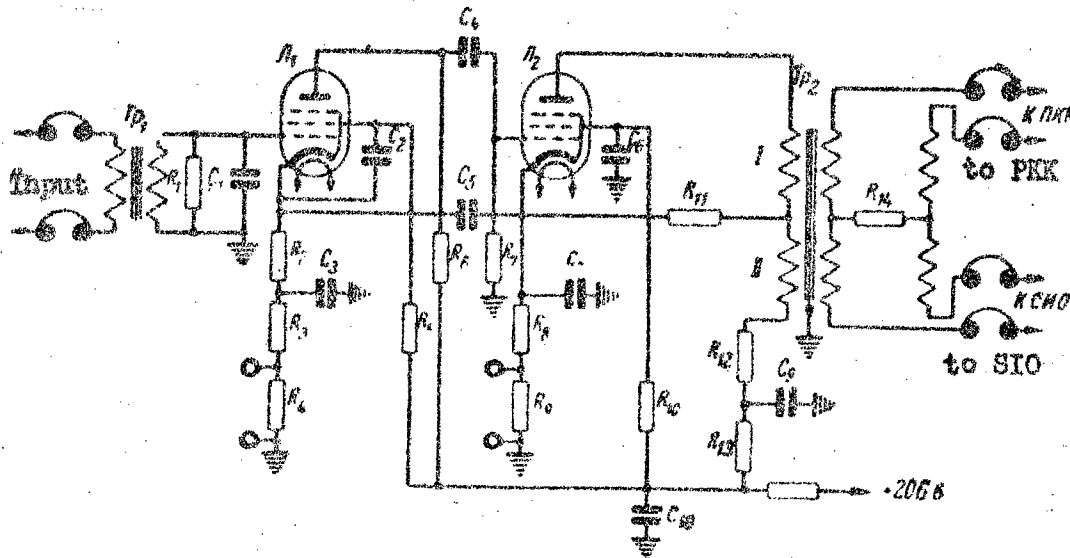

Amplifier Us. pr has the following principle parameters. Amplification in the operation frequency band is 5.5 nepers, the nominal level at the output is -0.6 nepers, nominal value of input and output impedances is 135 ohms; the amplitude characteristic maintains its straight line up to the output level of + 1.5 nepers; nonlinearity attenuation at the second harmonic is not less than 8 nepers and at the third harmonic not less than 9.5 nepers.

Structurally the reception amplifier is made in the form of cut-in block, which is placed on one panel with band filter GPF filter D-200 and with two route converters of reception route frequency.

4.9 Group route equalizers

Group route equalizers Vyr. per A-B and Vyr. pr A-B serve to compensate the amplitude frequency distortions, introduced by different group equipment units and principally by the filters DK-33, DK-88, D-88 dop, K-88 dop, and D-153. The mentioned distortions arise at the ends of operation frequency band and are close in character in the terminal and also in the tandem stations. Therefore, all group route equalizer circuits are analogous and differ from each other only by element values entering into the equalizers.

The principle group route equalizer circuit is illustrated on Fig. 4.15a, which consists of two unbalanced bridged-T sections. Inductors with cores SB from carbonyl iron and mica capacitors SGMZ are the elements of the equalizer. Resistors R_2 and R_4 are connected into the equalizer circuits, with the aid of which the steepness of equalizer attenuation curve can be changed at the ends of operation frequency band.

On Fig. 4.15b and c, the equalizer attenuation characteristics for transmission routes of racks SGO-B and SGO-A are illustrated, and on Fig. 4.15d and e, the attenuation characteristics of reception route equalizers for racks SGO-B and SGO-A are illustrated the band shape characteristics at the ends of operation frequency range is obtained when resoldering the resistance R_2 and R_4 taps which are connected in the longitudinal and also in the transfer equalizer branches.

Group route frequency characteristic is usually correct by equalizers when the equipment is adjusted in the factory. In operation conditions the group route should be equalized by correction to terminal networks which are present in the cathode circuits of the regulating amplifiers.

Structurally each equalizer should be mounted in different block, which has a turbonit cover with clamps on which all necessary resolderings are made. Attenuators for 0.1, 0.2 and 0.3 nepers the inputs and outputs of which are also brought out to the terminals on the block cover, are also arranged in the same block.

The attenuators serve to fix the required level values and therefore are included in the route with

Fig. 4.15 Circuit and characteristic of group route equalizers.

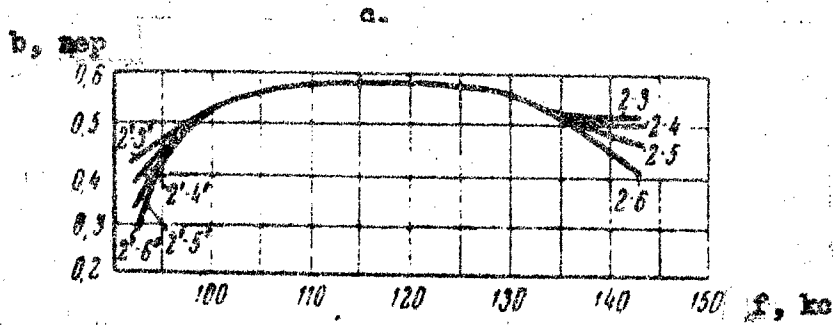
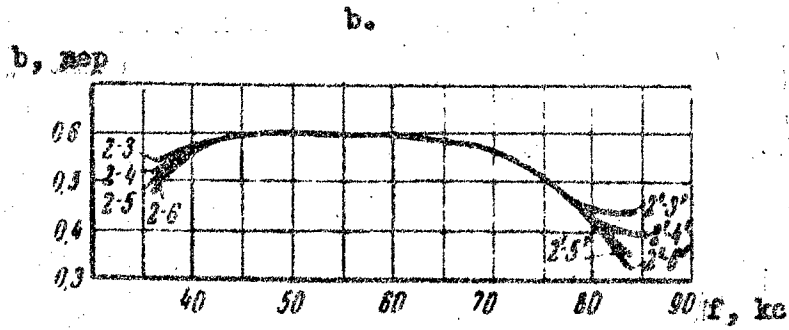
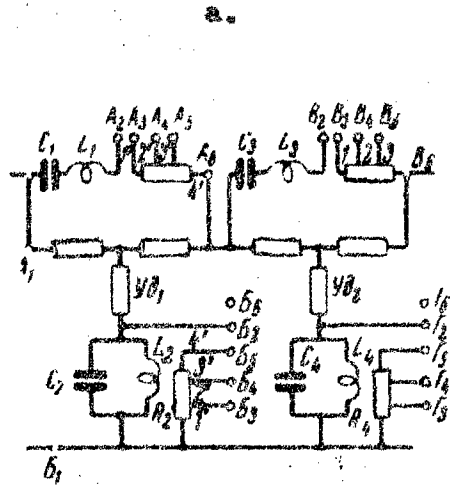
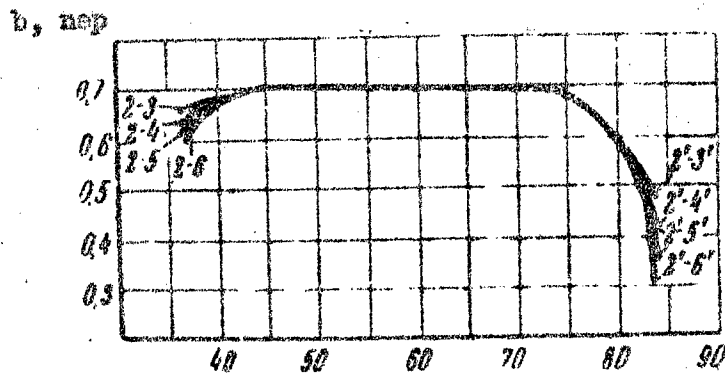
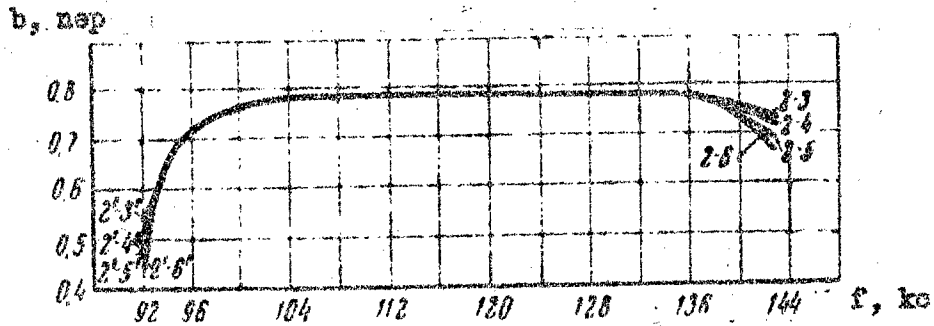

Fig. 4.15 (Continued).

d.



e.



factory adjustment of the equipment.

4.10 Terminal station group route filters

Band elimination filters ZF-A and ZF-B. Band elimination filter ZF-A (Fig. 4.16) is installed at the input of terminal office A group equipment, and filter ZF-B (Fig. 4.17) - in office B. The purpose of these filters was mentioned in section 1, chapter 2.

Fig. 4.16 Circuit and characteristic of ZF-A filter.

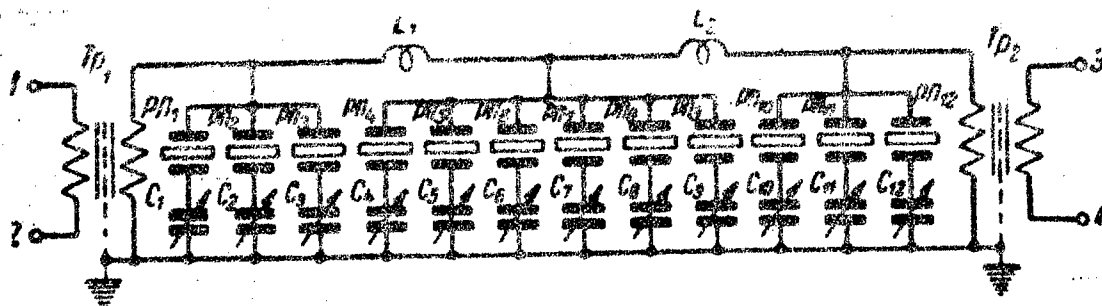

b, nep

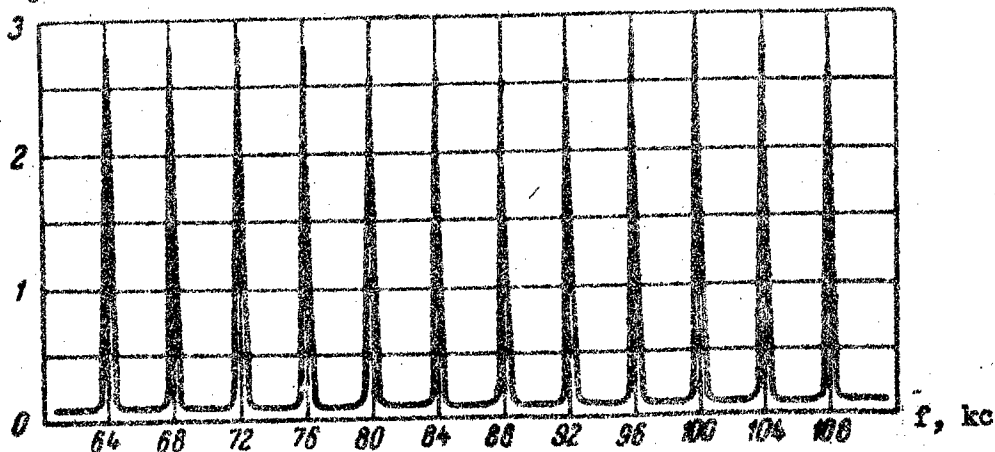

Filter attenuation on the spectrum frequency sections occupied by the channels is not over 0.1 nepers, and at frequencies coinciding with individual carrier frequencies for filters ZF-A is greater than 2 nepers and for ZF-B greater than 3 nepers.

Such conditions can be fulfilled only with the presence of quartz resonators. Owing to the high quality factor, they introduce attenuation in very narrow frequency band, which includes the suppressed carrier frequency. Besides resonators, the capacitors (mica and

ceramic with variable capacitance) are also used in the filter, and also the inductors with ferrocarr magnetic circuit.

Fig. 4.17 Circuit and characteristic of ZF-B filter

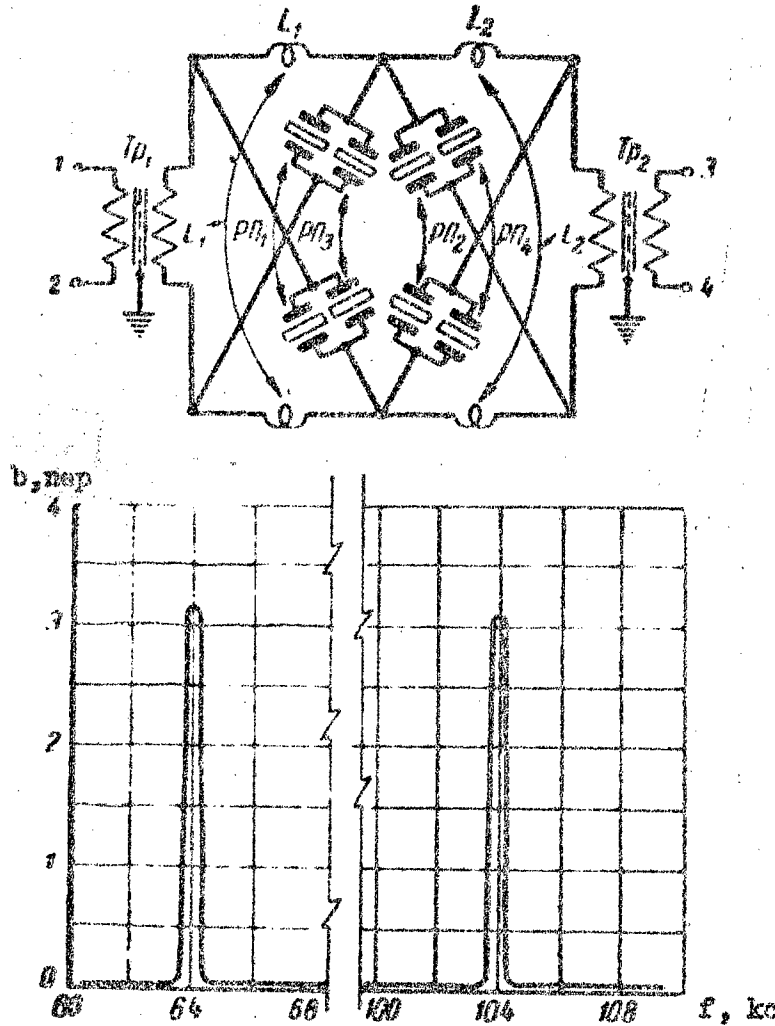

Filter elements are placed in hermetically sealed housing, inside which are also found the matching transformers, which fix the load resistance (135 ohms) input and output filter impedances.

Filters GPF and D-200. Filters GPF (Fig. 4.18) and D-200 (Fig. 4.19) are placed after the group converters of the terminal office and are intended to derive useful conversion products.

Fig. 4.18 Circuit and characteristic of GPF filter

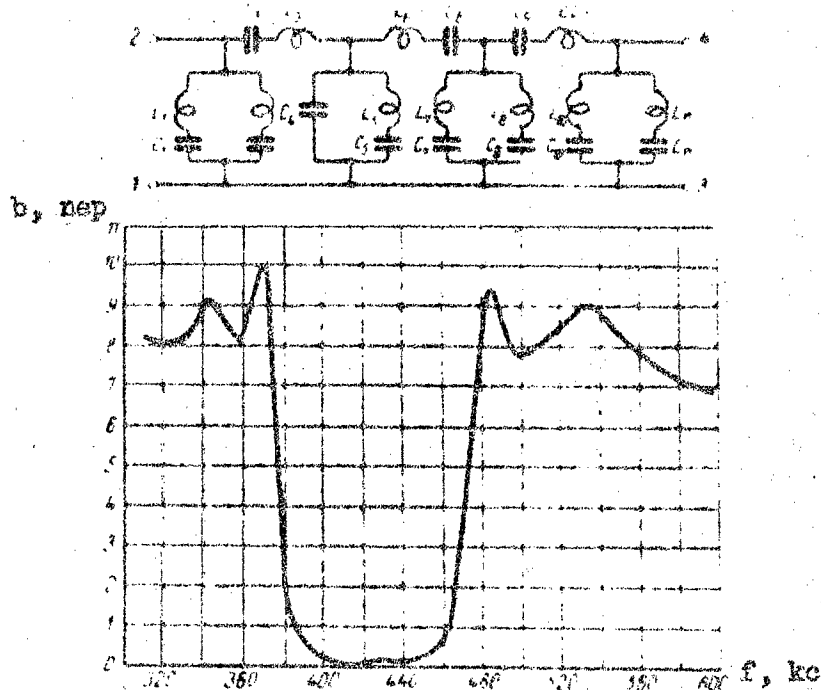

Both filters are accomplished by unbalanced circuit and have input impedances in pass band equal to 135 ohms. The attenuation of filter GPF in the frequency band 400 to 448 kc is not over 0.15 to 0.25 nepers, and in the attenuation band it is greater than 7 nepers. Attenuation of filter D-200 is not over 0.1 nepers at frequencies up to 150 kc, and it is greater than 7 nepers at frequencies above 240 kc.

Structurally, the filters are made in the form of hermetically sealed blocks. Mica capacitors and inductors with shell type cores of carbonyl iron are the filter elements.

Filters, K-77 and K-22. Filter K-77 (Fig. 4.20) serves to amplify the effect of the directing filter K-88, protecting the receiving route of the terminal

office A from interferences which originate in the transmission route of the same office.

Fig. 4.19 Circuit and characteristic of D-200 filter.

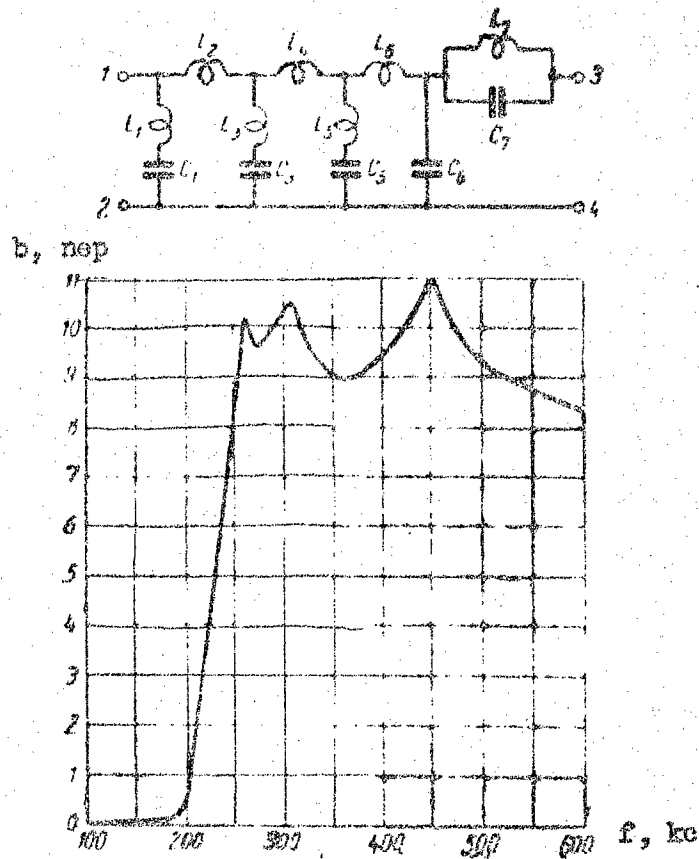

office A from interferences which originate in the transmission route of the same office.

Filter K-77 is accomplished by an unbalanced circuit and has input impedances in pass band equal to 135 ohms. The filter attenuation in the pass band from 90 kc and higher is 0.1 neper, and in the attenuation band more than 4 nepers.

Inductors with shell type cores from carbonyl iron and mica capacitors are the filter elements.

Filter K-22 (Fig. 4.21) serves to amplify the effect of flying filter K-33, preventing the current transfer from the 3 channel system into the low frequency group route of the 12 channel system. This filter is also made by an unbalanced circuit and also has input impedance in pass band equal to 135 ohms. Filter attenuation in pass band from 22 kc and higher is 0.15 nepers, and in the cutoff range about 4 nepers.

Inductors with toroidal cores from carbonyl iron and mica capacitors are the filter elements.

All examined filters are placed in hermetically sealed housings and the connection of inside filter wiring with the outside is made through glass insulators with metallic tube.

Fig. 4.20 Circuit and characteristic of K-77 filter.

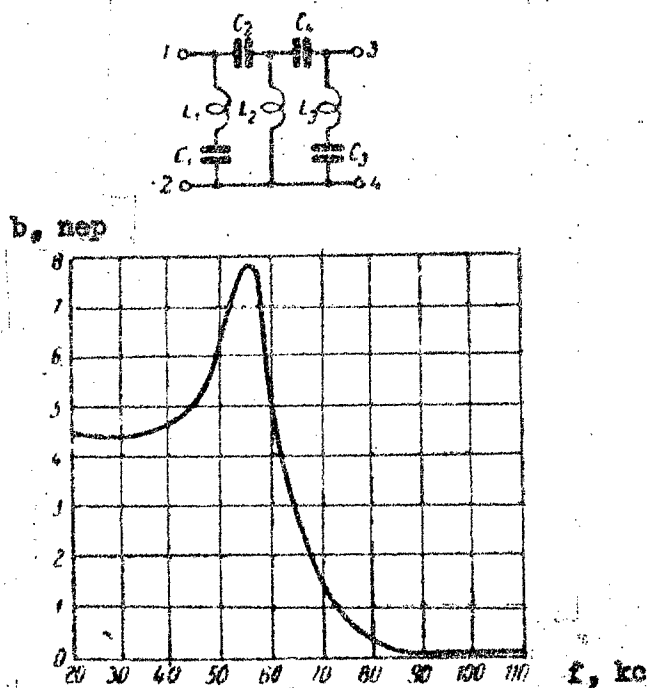
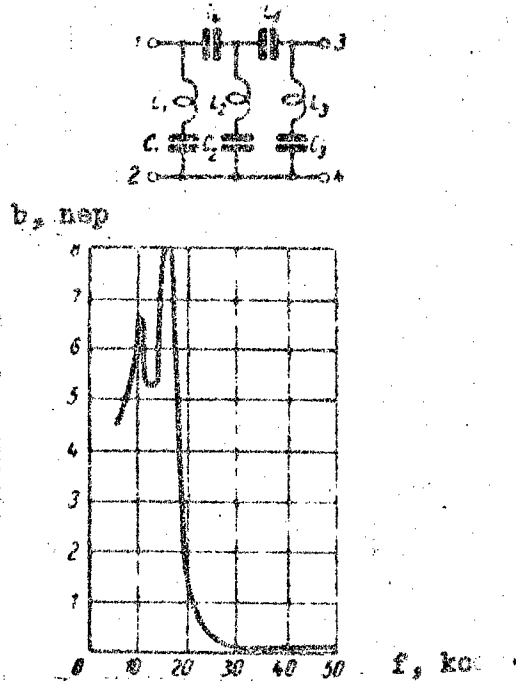

Fig. 4.21 Circuit and characteristic of K-22 filter.



Chapter 5. Generator equipment

5.1 General information

Stable operation of generator equipment in many ways determines the operation dependability of the entire system.

The terminal office generator equipment of V-12-2 system should provide the formation of 12 separate carrier frequencies (64, 68, 72, 76, 80, 84, 88, 92, 96, 100, 104 and 108 kc), the 340 kc group carrier frequency and also 2 carrier frequencies and 2 control frequencies determined by one of the alternates of the line spectrum and office type in correspondence with table 5.1.

Name of Frequency	Frequency (kc) with spectrum alternatives							
	I		II		III		IV	
	st.A	st.B	st.A	st.B	st.A	st.B	st.A	st.B
Second group transmission conversion..	308	484	543	364	541	484	306	364
First group reception conversion.....	484	308	364	543	484	541	364	306
Flat regulation pilot.....	60	64	111	104	109	64	58	104
Slope regulation pilot.....	111	104	60	64	58	104	109	64

Table 5.1 Group and pilot frequency values for different spectrum alternatives.

On the reliable operation of generator devices depend the transmission quality and in the first place such properties as speech intelligibility, timbre preservation and also stability of the principle channel characteristics the absence of outside interferences in them and so on.

Speaking on the generator stability, we have in mind in the first place the constancy of frequency value in time and with the influence of different unfavorable factors (variation of temperature and power supply voltage, replacement of circuit elements and their aging) and the studiness of level value also with different equipment operation conditions.

Although it is known that with the transmission of conversation the displacement of the entire voice-frequency spectrum up to 15 to 20 c at the reception relative to transmission does not effectively distort the speaking signals, perceived by the ear, nevertheless requirements for carrier current generator devices determine the permissible value of this displacement for one transducer section is not greater than 1 c.

This requirement for the high frequency stability

is determined by the necessity for transmitting voice-frequency telegraph signals, photo-telegraph signals and broadcasting programs through telephone channels with second system multiplexing. For these kinds of communication the lowering of generator stability leads to non-permissible distortions; with telegraph transmission - to sing distortions, with broadcasting transmissions - to the violation of sounding naturalness.

Requirements for frequency stability of control current generators ($2 \cdot 10^{-5}$) are determined by the narrow band quartz filters of the control channel receivers.

It is no less important to have a stable level of control signals, since its oscillation disturbs the main line level diagram, causing either amplifier overload or a decrease of the ratio signal over noise. Besides that, level variation of control currents and also of carrier frequency currents leads to stability disturbance of the overall channel attenuation. The terminal office generator system of V-12-2 equipment has an essential difference from V-12 equipment inserted construction and also in the principle and structural working of separate units.

5.2 Block diagram

Block diagram of the generator equipment is given on Fig. 5.1, which provides the formation of all necessary frequencies. The principle frequency of 4 kc is generated by quartz oscillator G-4, which has a stability not lower than $2 \cdot 10^{-6}$.

From the 4 kc oscillator output the voltage is applied to the 4 kc power amplifier input (Us-4) and further to the harmonic oscillator which is structurally combined with the amplifier. In the harmonic oscillator the sinusoidal oscillations are converted into sharp pointed impulses which contain a large number of harmonic components of the oscillations with slowly decreasing amplitude. The impulses at the harmonic oscillator output are symmetrically arranged on both sides on the time axis and contain therefore only odd harmonics of the fundamental frequency. In order to obtain even harmonics which determine the current production for a number of separate carrier frequencies, it is necessary to have an impulse series

Fig. 5.1 Block-diagram of generator equipment.

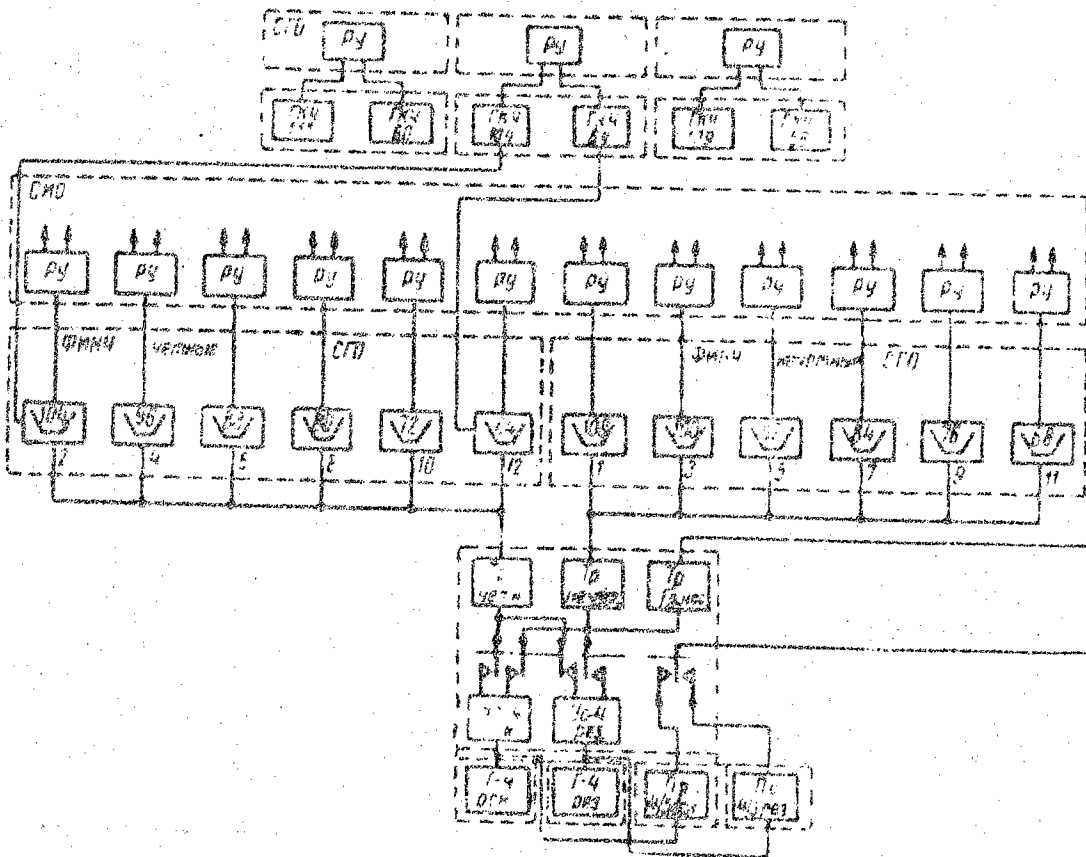
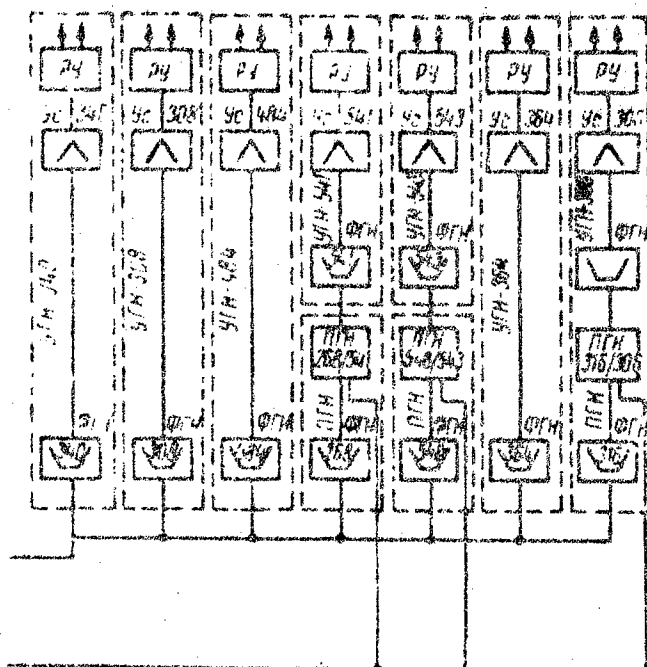

Fig. 5.1 (Continued).



located on one side of the time axis, which is provided by a rectifier bridge.

From the harmonic oscillator outputs, the 4 kc current pulses enter the parallel connected narrow band separate carrier frequency filters FINCH through the matching transformers. Each filter passes only one frequency which corresponds to some separate conversion frequency, suppressing all others which are different from the pass frequency by 4 kc and more. At the output of each filter a simplest distributing device RU is connected which makes possible the simultaneous feeding of modulators and demodulators of 2 like channels (i.e. 4 converters). This possibility can be used when feeding 2 V-12-2 systems from one generator equipment.

The group carrier frequencies 308, 340, 464, 484 kc, etc. are the odd harmonics of the 4 kc fundamental frequency, are derived by the corresponding group carrier frequency filters FGN.

Connection of amplifiers after filters FGN is determined by the large harmonic numbers in conjunction with the necessity of providing power for group carrier currents (30 mw) on each fed frequency converter. Distributing devices RU for the group carrier currents are also designed to feed 2 V-12-2 systems.

Somewhat more complicated is the production of the group carriers which are not harmonics of the fundamental generator frequency. An auxiliary 5 kc frequency (or its harmonic), which is summed in special group carrier converters PGN with 4 kc frequency harmonics, is used in the formation of group carriers. In addition to this the formation of other 3 group carrier frequencies is made in the following way:

$$\begin{aligned} 543 \text{ kc} &= 548 \text{ kc} - 5 \text{ kc} = 4 \times 137 - 5 \times 1, \\ 306 \text{ kc} &= 316 \text{ kc} - 10 \text{ kc} = 4 \times 79 - 5 \times 2, \\ 541 \text{ kc} &= 268 \times 2 + 5 \text{ kc} = (4 \times 67) 2 + 5 \times 1 \end{aligned}$$

Circuit construction for the formation of these three frequencies after the converters PGN are completely analogous to circuit construction for the direct separation of the necessary harmonic.

The auxiliary 5 kc frequency is formed in a special 4 kc frequency converter PR_{4/5}. This converter consists of a series connected multiplier, after which a 20 kc frequency is formed, and 2 frequency dividers with division coefficient q.

To raise the operation dependability of the generator equipment, the master oscillator, the 4 kc amplifier with harmonic oscillator and 4/5 kc converter Pr are reserved. Switching over to reserve set is accomplished manually by a switch.

Control currents with frequencies 60 to 111 kc and 58 to 109 kc are produced by independent generators with quartz stabilization. Control currents with frequencies 64 to 104 kc, coinciding in their frequency with the separate carrier frequencies of the second and

twelfth channels are produced by generators that are synchronized (or held) by the currents of these carrier frequencies.

As seen from the examined block diagram, the stability of all carrier frequencies is determined by the stability of the master 4 kc oscillator, i.e. equals $2 \cdot 10^{-6}$. This provides a frequency displacement of the operating signal, passing the terminal office route, by a value not greater than 0.3 c. Stability of control frequencies, produced by the independent generators, is not required to be that high, and therefore, it is taken equal to $2 \cdot 10^{-5}$.

The equipment located on separate panels is circumscribed by dotted lines on the block diagram.

The cut-in block construction permits to assemble easily on the rack that generator equipment which is necessary for the given terminal office, operating on a specific line spectrum alternate. When changing from one spectrum alternate to another, the UGN blocks with FGN filters and also the control frequency generators should be replaced. PGN and Pr 4/5 converters are additionally installed for II, III and IV spectrum alternates.

5.3 Master oscillator

Basic circuit for the master oscillator is given on Fig. 5.2. The generator is made as a bridge circuit with thermistor and tuned circuit in the plate circuit of the output tube. * The bridge arms are formed by (* At present, tubes 10 ZH1L are used in generator G-4. In the future, the generator tubes are proposed to be changed to 6ZH1P-E) quartz resonators RP_1 , thermistor L_7 , resistors R_{12} and R_{13} . The plate circuit LC_{9-10} of tube L_2 is tuned to the frequency 4 kc.

The thermistor L_7 stabilizes the oscillating voltage on the quartz resonator and provides a constant output level. The variable capacitance C_3 permits to tune the generator frequency in the range (+ 70 to -100) times 10^{-6} (0.3 to 0.4 c). Increase of the regulation reserve in the direction of frequency lowering is explained by the presence of natural process of generator frequency increasing as a result of quartz resonator aging, which

in the first months of operation is $(20 \text{ to } 30) \cdot 10^{-6}$. The generator frequency stability with the action of other influencing factors (oscillation of feeding voltages by plus or minus 10%, variation of surrounding temperature, tube replacement) does not go beyond the range $5 \cdot 10^{-7}$.

Control of thermostat heating and signalling notifying the disturbance of its normal thermal condition, is made by 2 thermal contacts Tk_1 and Tk_2 , tube L_3 (10ZHIL) and 3 relays P_1 , P_2 and P_3 (Fig. 5.3).

The temperature in the thermostat plus 15°C should be held with an accuracy of ± 0.2 degrees. Thermostat winding 1-2 is the heating winding; it is connected by relay P_3 contacts. Measuring winding 3-4 made of copper wire permits to control the temperature inside the thermostat by measuring its resistance which is beforehand determined at $\pm 20^\circ \text{C}$ temperature. Usually its value is in the range 600 to 700 ohms.

Fig.5.2 Master oscillator circuit

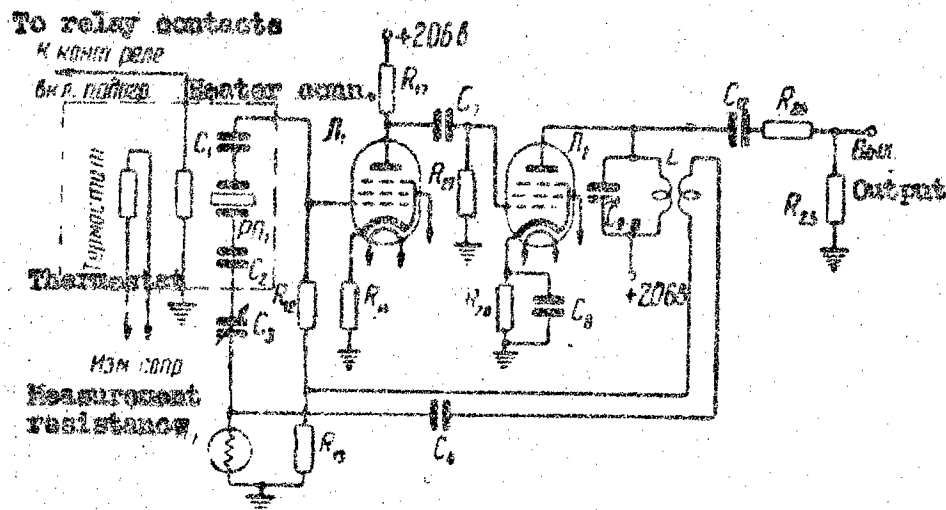

The circuit operating dynamics are as follows. After the generator is turned on, the thermostat heating begins which lasts for about an hour. During this time, the lamp L_5 (Term.vkl) is on, since the mercury in the thermal contact Tk_1 has not yet reached contact 2. At the same time the grid bias of tube L_3 is fixed by potential formed at a point between the plate divider resistors R_1 and R_4 . The tube is open, and the current flowing in the plate circuit causes the operation of relay P_3 , the contacts of which together with the heating winding turn on also the lamp L_5 .

If the temperature in thermostat is $+50^\circ C$, then contacts 1 and 2 of the thermal regulator Tk_1 are closed through a mercury column and "ground" (i.e. $-206 v$) is applied to tube L_3 grid. The tube is cutoff, relay P_3 drops out turning off the heating winding and signalling. A new lowering of mercury level below contact 2 in Tk_1 causes heating to turn on. Thus, tube L_3 permits to fix exactly the switching on moment and the switching on of the heating winding, which determines the negligible temperature oscillations inside the thermostat.

The thermal contact Tk_2 controls the operation of polarized relay P_2 . If the mercury level in Tk_2 is above contact 2 but below contact 3, relay P_2 armature is in the neutral position, since the currents in both windings determined by resistors R_{10} and R_{11} are approximately equal. If the mercury is at the level of contact 3 or below contact 2, (which occurs when temperature in the thermostat for some reason reaches correspondingly 54 or $44^\circ C$), then the ampere turns of some winding predominate and relay P_2 armature is closed with one of the contacts. Following this relay P_1 operates and the emergency signalling is turned on (lamp L_4 is on), which indicate the inaccuracy of the thermostat heating system.

The signal lamp L_6 Gsm. razr. illustrated on Fig. 5.3 lights on in the principle generator block when it is switched over to the reserve (or vice versa). Master 4 kc oscillators of type G-4 (principle and reserve) are fixed on the backside of the rack on its upper part.

Fig. 5.3 Regulation circuit by heating thermostat.

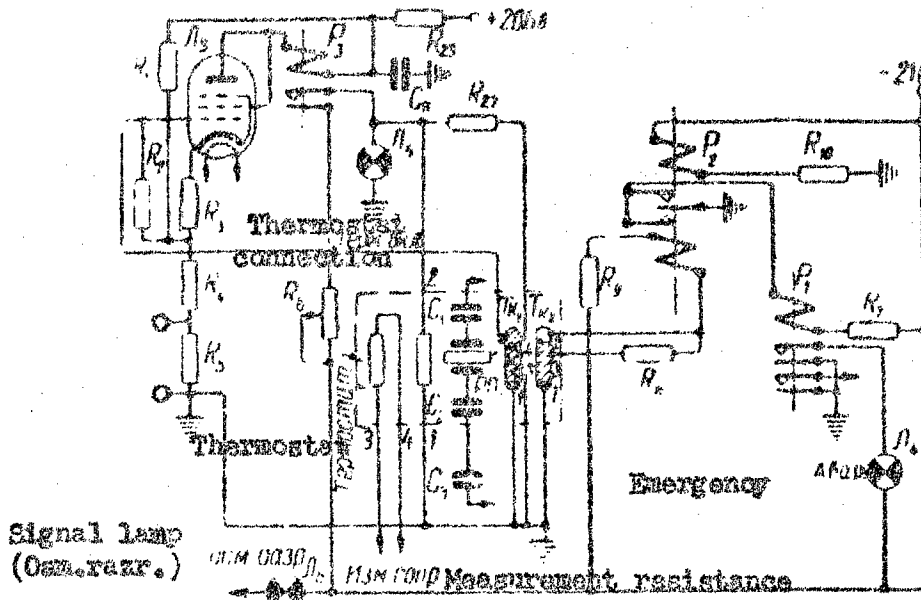

Generator G-4 is made in the form of cut-in panel. The 4 kc quartz resonator is enclosed in the thermostat, the structure of which is shown in Fig. 5.4. Its thermal insulation is provided by a felt layer (2), laid between the massive aluminum cylinder (1) and external bucket (3). Thermostat windings are wound on the external cylinder side (4). Thermal contacts of the thermostat (at 50°C and 44 to 54°C) are enclosed in protecting tubes (5) and can be removed (screwed off) from the external panel side.

The variable capacitor installed in the generator for frequency tuning is provided by a vernier which insures smooth motion of the capacitor rotor.

5.4 4 kc amplifier and harmonic oscillator

Principle circuit of the 4 kc amplifier and harmonic oscillator is given on Fig. 5.5. The amplifier is made with a resonance circuit with tubes 6ZH1P-E (preliminary stage) and 6P3S-E (output stage). The power at amplifier output is not less than 3 W. In order to

obtain sinusoidal oscillation forms at the amplifier output, which is very important for undistorted harmonic oscillator operation, apart from the parallel circuits in the first and second stage anode circuits ($Tr_1 - C_5$; $Tr_2 - C_9-10$).

Fig. 5.4 Generator G-4 thermostat.

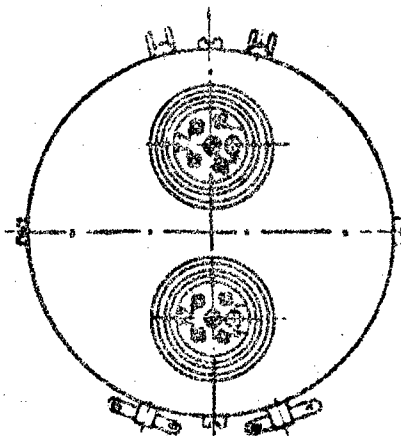
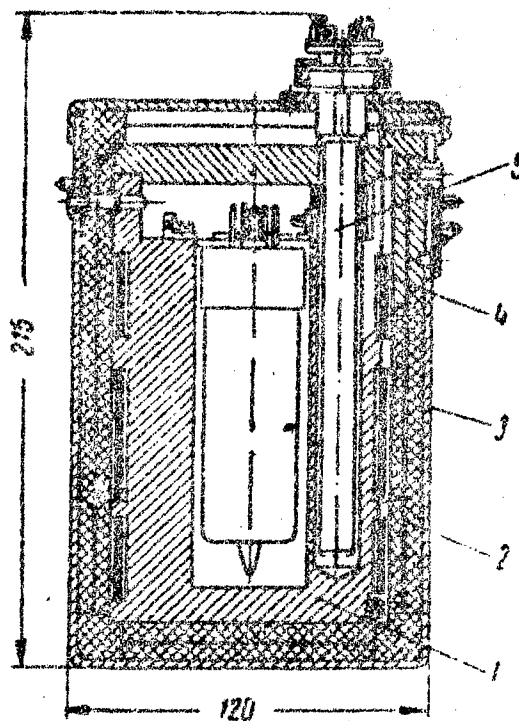

Owing to the presence of these circuits, the harmonics and 4 kc frequency formed in the harmonic oscillator are not shunted by the amplifier output impedance.

Fig. 5.5 4 kc amplifier and harmonic oscillator circuit.

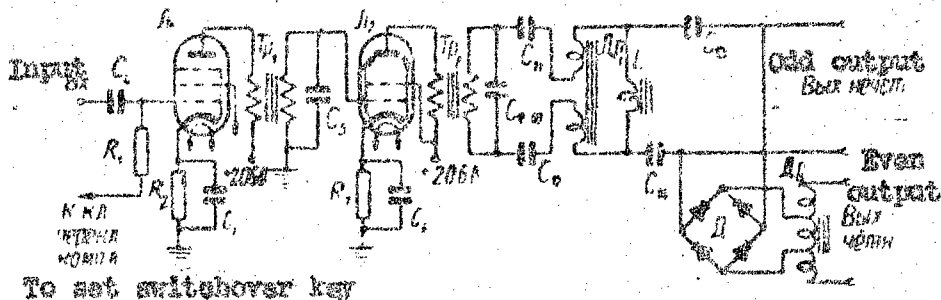

The harmonic oscillator consists of coil L and capacitors C₁₃ and C₁₄. A selection of permalloy rings each 50 to 60 mk thick were used in the coil core. The coil inductance sharply depends on the value of the current flowing through it. With large inductance value of coil L, when the instantaneous current value is close to 0, capacitors C₁₃ and C₁₄ are charged. With staggering inductance decrease, determined by quick saturation of the core material, when the instantaneous current value approaches the amplitude value, capacitors are discharged through load resistance and inductor. This process is repeated in the following period. The

discharge current pulses have sharp pointed form, are alternating according to direction, and therefore contain a large number of odd harmonics. Even harmonics of 4 kc frequency are obtained after full wave rectification (rectifier D) of the 2 way pulses.

The harmonic oscillator has 2 outputs; Vykh. nechet. and Vykh. chet., 2 direction pulses are present on the first output, and 1 direction pulse is on the second. The operation of 4 kc amplifier and harmonic generator to a greater degree depends on the exact correspondence of some circuit elements to their nominal parameters, than the operation of other units. Thus for example, it is very important that the data of the output tube and especially of the non-linear coil would not change noticeably during the operation time.

Two cut-in blocks Us-4 (principle and reserve) enter into the 4 kc amplifier plate. The switching over of amplifiers Us-4 (together with generators G-4) is made by a switch in the middle of the panel.

5.5 Current amplifiers for group carrier frequencies

Current amplifiers for group carrier frequencies UGN are made according to three different circuits. This is determined by the difference in their operation conditions. Amplifiers UGN for frequencies 340 kc (Fig. 5.6), 308 and 364 kc (Fig. 5.7) are one-stage resonance amplifiers with tube 6ZH1P-E. The voltage at their input is 0.7 to 1.5 volts. UGN for frequency 340 kc in distinction from the other amplifiers is designed to feed 4 group converters, which make it necessary to introduce into it 2 tubes 6ZH1P-E operating parallel to the load.

Amplifiers UGN for frequencies 306, 484, 541 and 543 kc (Fig. 5.8) contain 2 amplifier stages. The signal voltage equals 0.05 to 0.10 volts at the amplifier input in view of the high number of the used harmonics and the introduction of addition filters and converters. Depending on the level oscillation of the amplified harmonic, the amplifiers operate in the clipping condition to decrease the power oscillation range at the amplifier output.

All amplifiers have transformer inputs and outputs.

Transformers Tr_1 and Tr_2 are made with carbonyl iron dust cores. They are tuned to the frequency of the amplified oscillations by capacitors C_{1-2} and C_5 (or C_9). In parallel with the secondary winding of output transformers Tr_2 , a signal device is connected, consisting of resistors which prevent output shunting, germanium diodes D2V forming the rectifier D and polarized relay P which turns on signalling. When amplifier output voltage is lowered by 0.5 volts, ampere turns predominate which are produced in the relay field winding. The relay armature is thrown over to the operation contact which turns on the signal lamp, placed on the signalling panel.

Fig. 5.6 Circuit of 340 kc group carrier frequency amplifier.

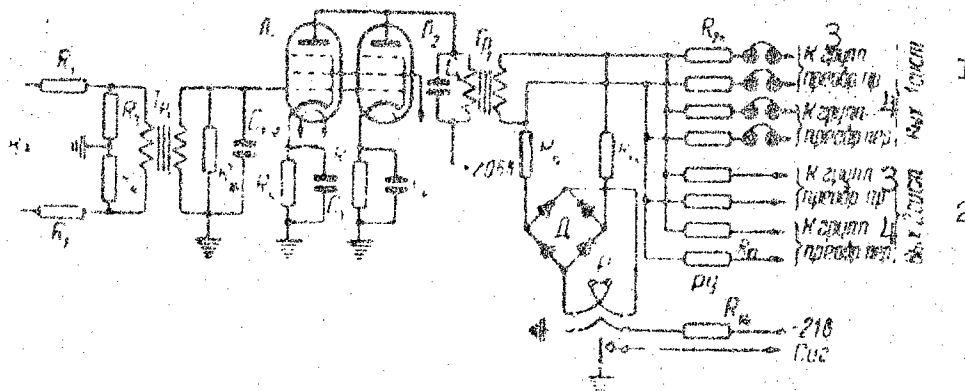

1. Output system 1.
2. Output system 2.
3. To reception converter group
4. To transmission converter group

All current amplifiers for group carrier frequencies UGN, with the exception of amplifier for 340 kc, have 2 outputs (according to the number of fed systems). If only one system is connected the other output is loaded by a 200 ohm resistance. Amplifier UGN for 340 kc has 4 outputs for 2 systems; the group reception converters and group transmission converters are connected separately.

Fig. 5.7 Circuit of 308 and 365 kc group carrier frequency amplifier.

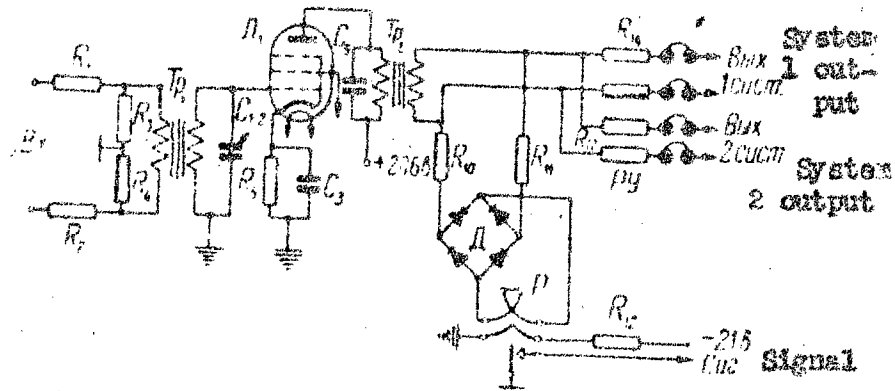
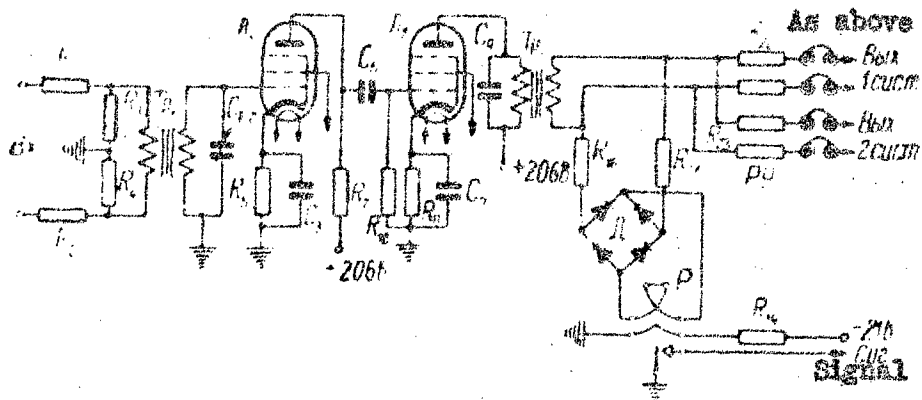

Fig. 5.8 Circuit of 306, 484, 541 and 543 kc group carrier frequency.



The group carrier frequency amplifier is structurally made in the form of cut-in block which occupies the right panel part. Shielded receptacle blocks are fixed to its front side, which connect the panel circuit with rack assembly with the aid of bows. Quartz filter for group carrier frequencies is installed in the left panel part.

5.6 Generator equipment filters

Two filter types enter the generator equipment: separate and group carrier frequency filters (FINCH and FGN). Principle circuits and characteristics for both filter types are given on Fig. 5.9 and Fig. 5.10.

The attenuation of these filters should increase fast on both sides of the pass bands in order that the 4 kc frequency harmonics, neighboring with the derived frequency, would not leak into the converters and would not cause the appearance of different interferences from additional conversion products. For this purpose, quartz resonators are introduced into the filters which provide:

a) in one section FINCH, 3000 c pass band; attenuation at rated carrier frequency f_n - 0.2 nepers; attenuation at frequency $f_n \pm 4000$ c - 4.5 to 5 nepers; input and output impedance 700 ohms; b) in 2 section FGN, pass band 400 c; attenuation at rated frequency f_n - 0.4 nepers; attenuation at frequency $f_n \pm 4000$ c - 8 nepers; input and output impedance 135 ohms.

Distributing devices RU are the last elements in all current feeding routes of separate and group carrier frequencies. As seen from Figs. 5.6, 5.7 and 5.8, this device consists of resistors, connected so, that the mutual effect of converters for different systems and transmission directions is eliminated.

It was necessary to use only one conversion stage to produce some group carrier frequencies (306, 541 and 543 kc). Converter PGN (Fig. 5.1) is made by a bridge circuit and operates between filters FGN which derive only the used frequencies.

5.7 4/5 kc converter

As was already stated, in order to form a number of group carrier frequencies, the presence of 5 and 10 kc

frequency is necessary.

Fig. 5.9 Circuit and characteristics of filter for individual carrier frequencies.

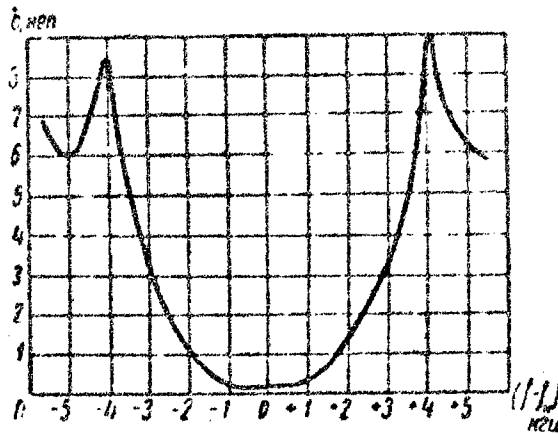
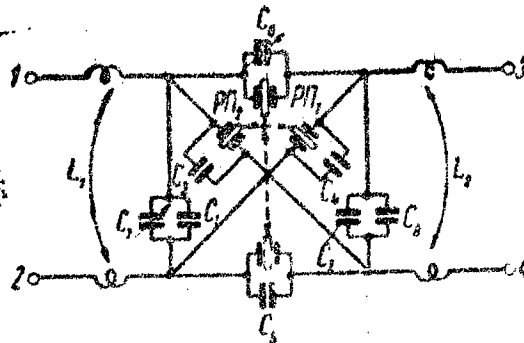

The 5 kc frequency is obtained from the fundamental 4kc frequency by a special convertor. Principle circuit of the convertor is given in Fig. 5.11.

The convertor contains 5 tubes 6ZH1P-E. First stage is intended to amplify the input signal with 4 kc

frequency, to which the circuit $C_5 Tr_1$ is tuned. Frequency multiplier is connected to amplifier input, consisting of germanium diodes D_1 and D_2 , which distort the curve shape of the fundamental oscillation and resistances R_6 and R_8 , which make the entire circuit symmetrical and make the diode replacement easier with the presence of some spread in their parameters.

Fig. 5.10 Circuit and characteristic of group carrier frequency filter.

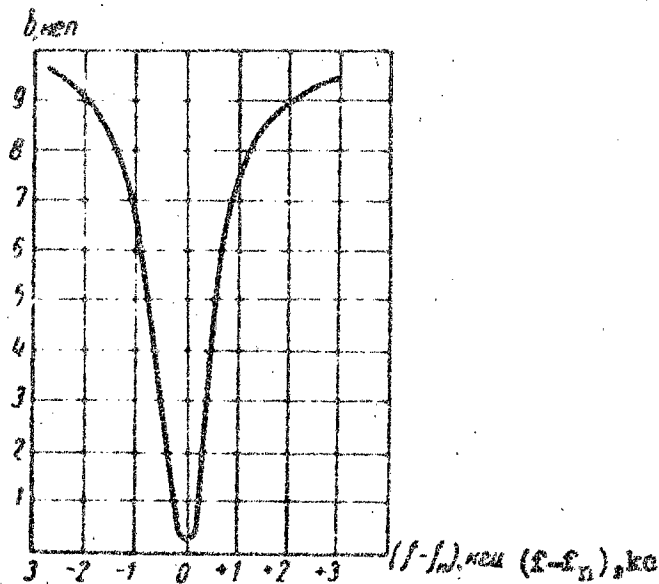
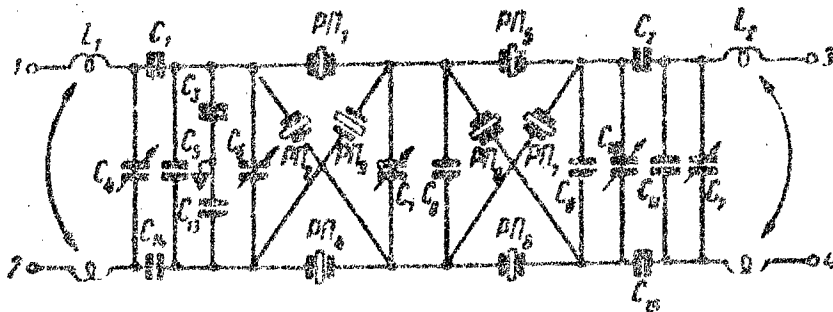
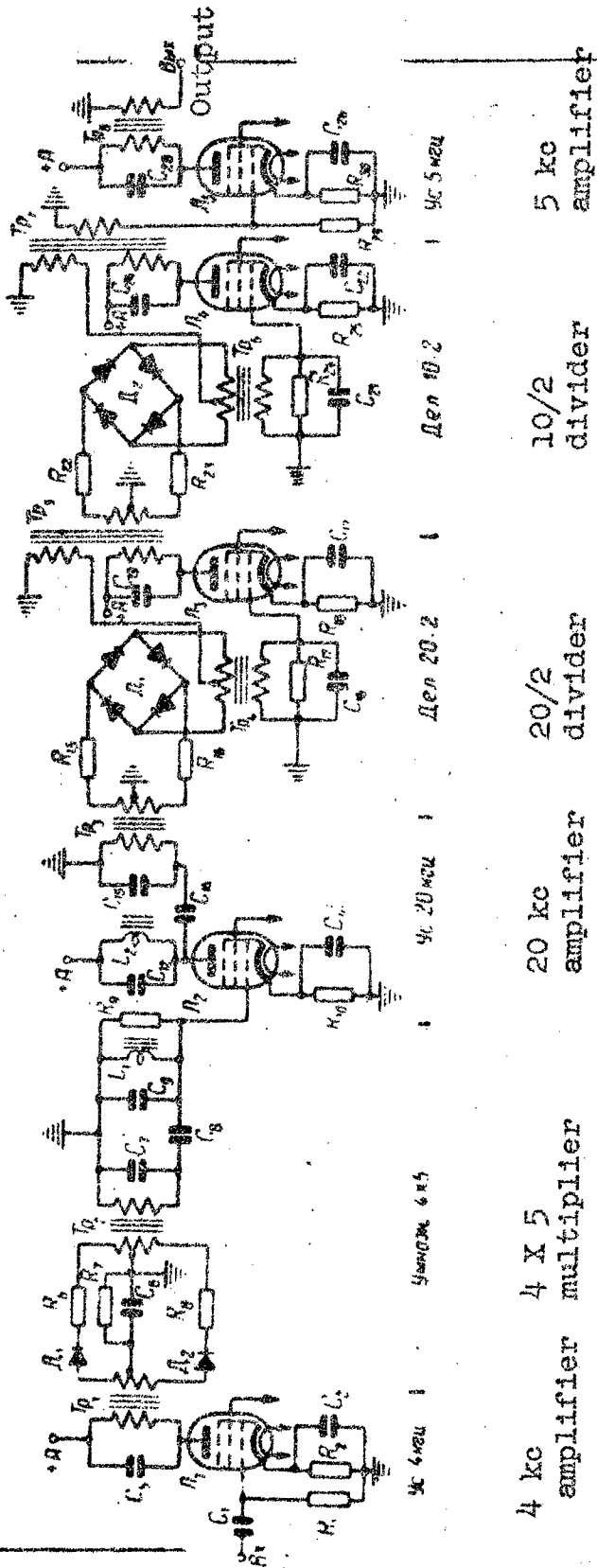

Fig. 5.11 Circuit of 4/5 convertor



4 kc	4 X 5	20 kc	10/2	5 kc
amplifier	multiplier	amplifier	divider	amplifier

The necessary frequency 20 kc, which is the smallest common multiple for frequencies 4 and 5 kc, is derived by circuits C₇ Tr₂ and C₉ L₁, is amplified by tube L₂ and is additionally filtered by circuits C₁₂ L₂ and C₁₅ Tr₃ which are also tuned to this frequency.

Third and fourth stages are frequency dividers with division coefficient 2, which provides the most stable circuit operation. At the output of the first divider the frequency value is 10 kc and at the output of the second, 5 kc. The frequency dividers represent 10 and 5 kc frequency current voltage generators, in the feedback circuits of which ring type modulators are connected. With the absence of external signal (20 kc) the ring type modulator D₁ has a high attenuation, therefore oscillations do not arise. When applying an external signal the modulator attenuation decreases up to a value at which the auto-generator is self-excited. The frequency of 10 kc (or 5 kc in the second divider) produced by it is applied to the modulator as the carrier frequency.

During the conversion a current with different frequency 20-10 kc (or 10-5 kc) is produced, which maintains generation with stability of the initial 20 kc oscillation.

Circuits C₁₆ Tr₄ and C₁₉ Tr₅ are tuned to 10 kc frequency and circuits C₂₁ Tr₆ and C₂₄ Tr₄ to the 5 kv frequency. Resistors R₉, R₁₇, R₂₄ are intended to shunt the grid circuit, which excludes the formation of self-oscillation. In the last stage a final filtration and amplification of 5 kc frequency current are made.

The converter input voltage can vary in the range 1.5 to 3.0 volts, the converter output voltage - not less than 5 volts (when connected to a real load). The 4/5 converter plate includes 2 cut-in converter blocks (principle and reserve) made according to the accepted principle for this system of cut-in constructions.

5.8 Control current generators.

Two types of control current generators GKCH are used in V-12-2 equipment: generators with quartz

stabilization at frequencies 58, 60, 109 and 111 kc and locked generators at frequencies 64 and 104 kc; locking is made by a voltage, the frequency of which is the corresponding harmonic of the master oscillator.

The principle circuit of generators with quartz stabilization is given on Fig. 5.12 and the locking generators on Fig. 5.13.

Fig. 5.12 Circuit of 58, 60, 109 and 111 kc control current generator.

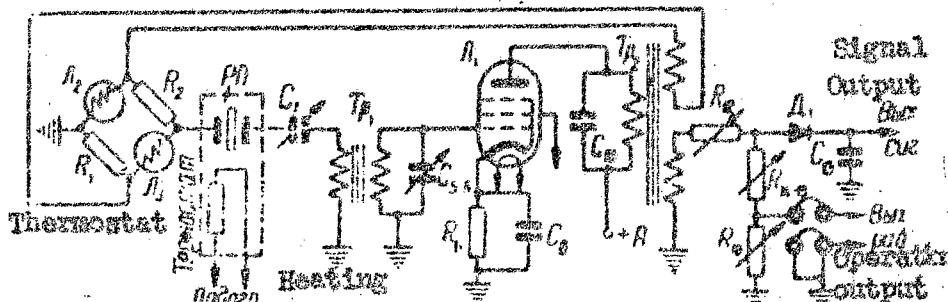
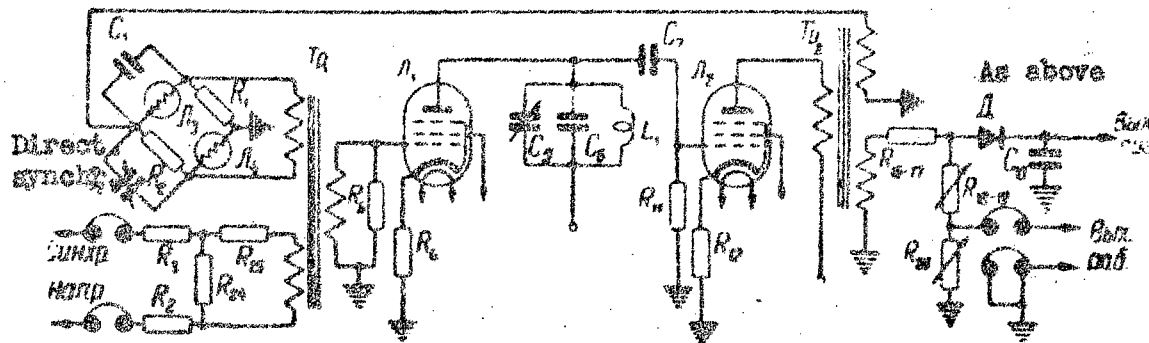

Fig. 5.13 Circuit of 64 and 104 kc control current generator



Quartz generators have only one tube 6ZH1P-E. Coupling between oscillating circuits C_{10} Tr_2 and C_{5-6} Tr_1 is accomplished by quartz resonators RP. For the stabilization of generator output power and the voltage on the quartz, a bridge is connected in the feedback circuit, 2 opposite branches of which have thermistors TP-2/0.5 (L_2 and L_3).

Any change of output level because of tube aging, voltage change of power supplies, etc. causes a change in the value of current flowing through thermistors, and consequently causes a change in their resistance. As a

result of this the feedback voltage changes correspondingly (on the primary winding of Tr_1), which leads to the maintainance of constant value for the output level.

The quartz resonator is placed to the thermostat to increase the frequency stability. The temperature regulation device in the thermostat in this case is simpler than that in the 4 kc oscillator, and besides a relay which turns on the heating and the thermal contactor, contains only a signal lamp which notifies the turning on of heating winding.

Capacitor C_1 serves for exact frequency adjustment of the generator, the stability of which during one month is held not lower than $2 \cdot 10^{-5}$. The generator output level is regulated by resistor R_{12} up to 0.15 nepers. For the control of generator output level volume and for sending the signalling with level deviation by + or - 0.05 nepers from the normal value, a rectifier made with diode D_1 in the circuit of which is connected the signal magneto-electric relay (not shown on the circuit) is connected to the output voltage divider.

A clear and exact signalling operation for the deviation of the level from the nominal value is very important, since its oscillations cause unnecessary operation of ARU system on the entire main line. Therefore the generator circuits provide a stability of the output level not smaller than ± 0.02 nepers from all the influencing factors.

The blocking generators have 2 tubes 6ZH1P-E. The plate circuit of the first tube $C_{5-6} L_1$ is tuned to the amplified frequency (64 or 104 kc). The feedback voltage is applied from the plate of the second tube to the grid of the first tube through a stabilizing bridge which is made similar to the previous circuit; in L_3 and R_2 bridge arms, capacitors C_1 and C_2 are additionally connected with the aid of which the set frequency tuning of the generator oscillations is made.

The locking voltage is applied through the third winding of transformer Tr_1 . The output circuit is made the same as that in the quartz generators.

Frequency stability of these generators is determined by the stability of the master oscillator: the output level stability, as in the previous case, is not lower than ± 0.02 nepers.

From the total number of 6 control current generators, provided by V-12-2 system, in each terminal station, depending on its type (A or B) and the line spectrum alternate, only two generators are installed, whereupon each of them can supply two systems by controlled currents.

Chapter 6. Tandem office

6.1 General information

Tandem office PS of system V-12-2 accomplishes the following functions: amplifies current of upper and lower frequency groups of the line spectrum; automatically regulates the levels in both transmission directions; separates the line frequency spectrum for systems V-3 and V-12-2; forms a channel for the line between operators in the voice-frequency spectrum.

Thus, the main purpose of tandem offices consists in increasing the communication distance, because with all things considered the accomplishment of the above listed functions serves just this purpose.

The tandem office route contains a number of units which were also used in the terminal office (see chapter 4).

Units which are characteristic only for the tandem office are filters DK-2.8, BDK-2.8 with line transformer Tr 600/600; bypass route equalizers VK-33; route equalizers Vyr. AB and Vyr. BA; speak-buzz device PVU; control channel receivers PKK.

As a rule, several tandem offices, and in many cases a number can reach several tenths, are installed between two terminal offices on the serial mains. Therefore the system operation stability and communication quality are determined to a large degree by the parameter stability of the tandem office.

A large number of such offices on multiplex lines causes the accumulation of different distortions, noises and interferences. It is obvious, that in each repeater office only such dimensions of distortions and level noises can be permitted, which would not disrupt normal communication with maximum transmission distances.

In section 6.2, some information is given on the

determination methods of set noises values for the tandem office and on the sources of their formation. Possessing information on the noise level at the output of one office, the protection value on the given specific main can be determined (with the consideration of terminal office set noises) and consequently the transmission quality can be judged.

6.2 Set noises and non-linear distortions of tandem office

The construction difference of low frequency and high frequency tandem office routes causes the necessity to evaluate in different ways the power of set noises which are introduced by each separate office route into the common line routes of the system.

Let us examine the low frequency route first. A simplified block diagram of equipment relating to this transmission direction is given on Fig. 6.1.

Fig. 6.1 Simplified circuit of the l-f route.

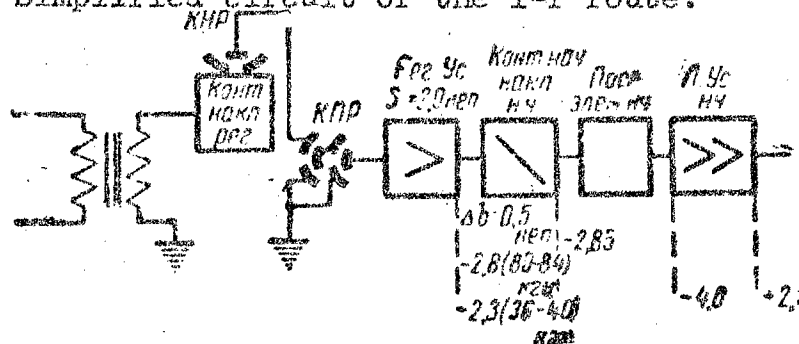

The regulating amplifier input in this circuit is a point with the lowest level, which determines the principle noise value. An additional factor, which increases the noise level, is the absence of grid transformer at the regulating amplifier input.

It is necessary to turn attention to two circuit features:

1. Connection of initial slope circuit determines the level difference for end channel current at the low level point at the value of circuit attenuation drop, i.e. at 0.5 nepers.

2. Independent of line attenuation, i.e. office amplification, the regulating capacitors KNR and KPR

hold constant (with ARU operation accuracy) the signal voltage at amplifier input.

With the consideration of the second feature, the problem of determining noise power in low frequency route for all possible amplification values reduces to level comparison of thermal and tube noises of the regulating amplifier with signal level at any known route point. It can be done most simply for the regulating amplifier output.

The equivalent circuit of regulating amplifier input is given on Fig. 6.2. In this circuit: C - the rotor capacitance of the flat regulation capacitor with respect to ground (with the consideration of assembling capacitance); depending on the position of flat regulation capacitor KPH, the capacitance C can vary in the range 20 to 70 uuf; R_1 and R_2 - amplifier circuit elements; the values of these resistances are correspondingly 430 kilo-ohms and 150 ohms; R_{sh1} - equivalent noise resistance of the tube; for the applied tube 6ZH1P-E, $R_{sh1} = 1800$ ohms.

Fig. 6.2 Equivalent circuit of the input of l-f route control amplifier and h-f route flat regulation amplifier.

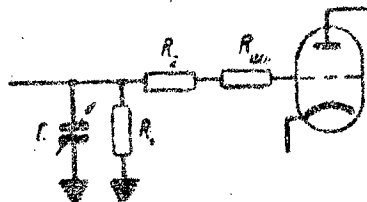

To determine the amplifier noise emf, it is necessary to know the real component of the total CR_1 circuit impedance, which with some approximation is expressed as

$$R_{sh} = \frac{1}{\omega C^2 R_1}$$

The total equivalent noise resistance equals

$$R_{sh} = R_{sh} + R_2 + R_{shA}.$$

Emf, formed in resistance R_{sh} , is determined by the well known expression

$$E_{sh} = 2 \sqrt{R_{sh} k T \Delta F}$$

and the noise voltage at the regulating amplifier output will be

$$U_{sh} = 2 \sqrt{R_{sh} k T \Delta F} e^{S_n}$$

Here k - Boltzman constant, equal to 1.38×10^{-23} , watt-second/degree; T - absolute temperature; F - frequency band width common c; S_n - amplifier amplification (voltage), nepers, in our case $S_n = 2.0$ nepers.

Knowing the load resistance ($R = 135$ ohms) and noise voltage at amplifier output, their power level can easily be determined and then, knowing the measuring signal level at this point, the noise power at 0 relative level point can be determined.

Calculation results of noise powers, produced by low frequency route of the tandem office, at the 0 relative level point are given in table 6.1.

The increase of office amplification is accompanied by a decrease of flat regulation capacitance (capacitance C), which involves the increase of set (thermal and tube) noises in the tandem office. From the examination of table 6.1 can be seen, that for the increase of line frequency spectrum, the power of set noises of the tandem office high frequency route decreases.

Regulating amplifier noises are adjusted to the noises of the entire low frequency route in the tandem office. The line amplifier set noises do not affect the total noise balance.

Noise power, produced by line amplifier at the 0 relative level point, can be determined from the expression

$$0.562 e^{2(P_{shu} - P_c)} 10^9,$$

where 0.562 - psophometric power co-efficient; P_{shu} - the amplifier set noise level, applied to its input (for line amplifiers in the V-12-2 equipment is -15.2

nepers); P_s - current level of 1 channel at the amplifier input (according to the level diagram 4.0 nepers).

Substituting numerical values, we will find that in any channel the noise power from line amplifier is 0.5 w.

Let us examine now the high frequency route, a simplified block diagram of which is given on Fig. 6.3. The input of flat and slope regulation amplifiers UPR and UNR are the low level points which determine the noise value. In order to determine the specific weight of each amplifier in the total noise value at a channel output, we will make calculations for following alternatives, analogous to the above stated: 1) noises, determined by UNR amplifier input; 2) noises, determined by UPR amplifier input with a 0 position of capacitor KNR; 3) the same, at 100ths position of capacitor KNR.

Channel frequency band kc	C, ppf	U_{sh}	U_{sh}	Noise level at the control amplifier output, nepers. (P_{sh})	Noise level at the point of zero relative level, nepers. (P_{sh0})	Noise power at the point of zero relative level, mW ($W_{sh\text{ eff.}}$)	Prophometric power in point of zero relative level, mW ($W_{sh\text{ proph.}}$)
36 ÷ 40	20	$2.42 \cdot 10^{-6}$	$17.8 \cdot 10^{-6}$	-9.95	-7.65	230	130
36 ÷ 40	70	$0.69 \cdot 10^{-6}$	$5.1 \cdot 10^{-6}$	-11.2	-8.9	18.3	10.5
80 ÷ 84	20	$1.09 \cdot 10^{-6}$	$8.07 \cdot 10^{-6}$	-10.7	-7.9	136	76.5
80 ÷ 84	70	$0.345 \cdot 10^{-6}$	$2.54 \cdot 10^{-6}$	-11.8	-9.0	15.2	8.55

Table 6.1 Values of noise power produced by l-f route.

Fig. 6.3 Simplified circuit of h-f route.

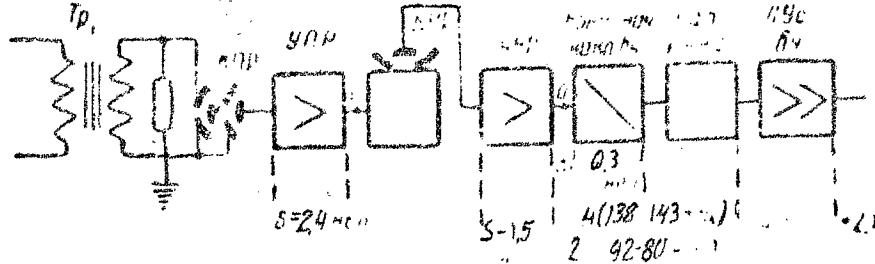

Initial data for the first alternate changes somewhat. The equivalent circuit of slope regulation amplifier input is given on Fig. 6.4. On this figure; C - total capacitance between rotor and two adjacent parallel connected stator plates, approximately equal to 130 f; resistors R_{10} and R_{11} are the circuit amplifier elements and equal correspondingly 430 kilo-ohms and 150 ohms; R_{sh1} has the previous values; R_n - load resistance of slope regulation circuits, = 600 ohms.

Fig. 6.4 Equivalent circuit of the slope regulation amplifier input.

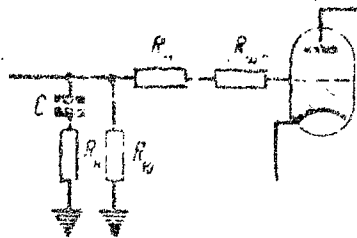

The real component of the total resistance of circuit $CR_n R_{10}$ is determined by the expression

$$R''_{u1} = \frac{R_{10} [1 + \omega^2 C^2 (R_{10} + R_H) R_H]}{\omega^2 C^2 (R_{10} + R_H)^2}$$

The total equivalent noise resistance in this case will equal

$$R_u = R_{u1} + R_{11} + R_{u1}$$

Further determination of UNR noise power at the 0 relative level point will be complete analogous to the

investigated case, in addition to this $S_n = 1.5$ nepers. Calculation results of noise power at UPR input are given on table 6.2.

It is advisable to examine this table together with calculation results of noise power, determined by UPR amplifier input. When making such calculation, the original principle pre-requisites remain the same as in the previous noise calculations for low frequency route. The equivalent amplifier input circuit (Fig. 6.2) is also kept the same. The difference is only in the amplifiers UPR amplification ($S_n = 2.4$ nepers) and also in the value of its output impedance (600 ohms), which should be considered when determining noise level at its output. Additionally, it should be kept in mind, that with capacitor KNR position "0" the RN-vch block (route section between points a - b on Fig. 6.3) in the frequency band 92 to 143 kc introduces attenuation of 1.0 nepers; with capacitors KNR position "100" the block has: for $f = 143$ kc $S = 1.1$ nepers, for $f = 92$ kc $S = -1.0$ nepers (attenuation).

The block amplification for intermediate frequencies can be determined from a straight line connecting 2 end points. Calculation results of noise powers at UPR input are given in table 6.3.

Comparing data of tables 6.2 and 6.3, the following conclusions can be made:

1. With small amplification of the tandem office (capacitors of the flat and slope regulations are close to 0 positions) the high frequency route noises are very insignificant and are principally determined by the slope regulation amplifier.

2. With office amplification close to limiting (capacitors of the flat and slope regulation are close to 100th position), the noises in lower channels are determined by both amplifiers to the same degree; in the upper channels the noises are completely determined by the flat regulation amplifier. More complete calculations show that the amplifier UPR influence begins in channels, the line spectrum of which occupies frequency region above 120 kc.

3. The slope regulation amplifier noises do not depend on the capacitors KNR position.

Total values of set noises in high frequency route (W_{ts}) are given in table 6.4. They are obtained by adding the data of tables 6.2 and 6.3.

The line amplifier noises as in the low frequency route, can be neglected.

The tandem office noise power, determined by non-linear distortions, when using the channels for telephone transmissions can be determined from the relations

$$W_2 = 4e^{4P_0 + 2P - 2b_{k20}} \frac{\Delta f}{\Delta F} Y_2 \kappa^2 10^9, \text{ nsm},$$

$$W_{31} = 24e^{6P_0 + 2P - 2b_{k30}} \frac{\Delta f}{\Delta F} Y_{31} \kappa^2 10^9, \text{ nsm},$$

$$W_{32} = 24e^{6P_0 + 2P - 2b_{k30}} \frac{\Delta f}{\Delta F} Y_{32} \kappa^2 10^9, \text{ nsm},$$

where W_2 - power of the second order non-linearity products; W_{31} - power of first kind third order non-linearity products; W_{32} - power of second kind third order non-linearity products; P_0 - the total load level at the 0 relative level point, i.e. the difference between average power level of all channels and the normal measuring level of one channel ($P_0 = 0.7$ nepers); P - the transmission level through one channel at the line amplifier output (+2.0 nepers); b_{k20} - the amplifier non-linearity attenuation at the second harmonic with 0 level at the amplifier output (10.8 nepers); b_{k30} - the same, for third harmonic (14.8); * Δf - the (* values b_{k20} and b_{k30} are taken from experimental data as average of a number of measurements.)

effectively transmitted channel frequency band (3.1 kc); ΔF - width of the frequency line spectrum (48 kc); Y - the co-efficients, characterizing the distribution of non-linearity products through the operating frequency spectrum; κ - psophometric power co-efficient.

The value P_0 is determined from the experimental graph of the total load of system group routes with

Table 6.2 Noise power values, determined by URN amplifier input.

Channel Frequency band kc	C_1 μF	E_{sh} V	U_{sh}	Noise level (according to power) at UNR output, nep. (P_{sh})	Noise level at zero point, nep. (P_{sh0})	Noise power at zero point level, μW . ($W_{sh\text{eff}}$)	Prophetic noise power at zero level point, μW . ($W_{sh\text{proph}}$)
92-96	130	$0.39 \cdot 10^{-6}$	$1.76 \cdot 10^{-6}$	-12.25	-10.15	1.72	0.95
139-143	130	$0.378 \cdot 10^{-6}$	$1.69 \cdot 10^{-6}$	-12.30	-9.9	2.52	1.42

Channel frequency band kc	C _{upr} , μf	E _{sh} , v	U _{sh} , v	Noise level (according to power) at UPR output, nep. (P _{sh})
92 ÷ 96	20	0.9 · 10 ⁻⁶	10 · 10 ⁻⁶	-11.25
92 ÷ 96	70	0.4 · 10 ⁻⁶	4.42 · 10 ⁻⁶	-12.1
139 ÷ 143	20	0.71 · 10 ⁻⁶	7.85 · 10 ⁻⁶	-11.5
139 ÷ 143	70	0.35 · 10 ⁻⁶	3.86 · 10 ⁻⁶	-12.2
139 ÷ 143	20	0.71 · 10 ⁻⁶	7.85 · 10 ⁻⁶	-11.5
139 ÷ 143	70	0.35 · 10 ⁻⁶	3.86 · 10 ⁻⁶	-12.2

Table 6.3 Noise power values, determined by UPR input.

Noise level (according to power) at UNR output, nep. (P_{sh}).	Noise level at zero level point, nep. (P_{sh}).	Noise power at zero level point, μW . ($W_{sh\ eff}$)	Prophometric noise power at zero level point, μW ($W_{sh\ proph}$)	Remarks
-12.25	-10.1	1.7	0.95	Amplification of slope control unit for frequencies 92-143 kc is $S = -1.0$ nep
-13.1	-10.95	0.3	0.17	
-12.5	-10.1	1.7	0.95	
-13.2	-10.8	0.41	0.23	
-10.4	-8.0	111.8	62.7	$S_{143} = 1.1$ nep.
-11.1	-8.7	27.6	12.8	

Table 6.3. (Continuation).

Channel frequency band kc	Route amplification	Resultant prophome- tric power at zero level point, μW (W)
92-96	min.	1.12
139-143	min.	1.65
92-96	max.	1.90
139-143	max.	64.1

Table 6.4 Values of the h-f route set noises.

different channel number; co-efficients Y - by graphs prepared by Brokbenk and Vass. These graphs were often given in literature and therefore are not repeated here.* (* K. P. Yegorov "Design Features of Distance High Frequency Communications Systems through Cables". Svyaz'izat, 1949. A. A. Leshchinskiy "Design of Multi-Channel Telephone Communication System through Coaxial Cable", Radiotekhnika No. 6, 1952.)

values of other parameters entering into the calculation are determined by the characteristic of the line amplifier for the entire system.

It is natural that for high frequency route $W_2 = 0$, since all second order non-linearity products go beyond the line frequency spectrum.

Calculation results noise power from non-linear transitions at the 0 relative level point are tabulated in Table 6.5.

Second kind third order non-linearity products are not considered here because of their negligible power (small value of co-efficient Y_{32}).

Having noise data of separate tandem office, the noise power at the zero level point can be calculated, which is determined by all stations of the main line.

For thermal and non-linear noises of the second order this can be made rather simply, in so far as

$$W_{tm} = nW_{ts} \quad \text{and} \quad W_{2m} = nW_{2s}$$

Frequency band	Nonlinearity products	
	W_2 $\mu\mu W$	W_{31} $\mu\mu W$
36-40	15	9
80-84	10	9
92-96	-	5
139-143	-	5

Table 6.5 Power values of noises from non-linear transits.

where W_{tm} - the thermal noise power for all main line for all main line offices at the zero relative level point, $\mu\mu W$;
 W_{ts} - the same, for one tandem office, $\mu\mu W$;
 W_{2m} - non-linear noise power of second order for all tandem offices on the main line at the zero relative level point, $\mu\mu W$;
 W_{2s} - the same, for one tandem office, $\mu\mu W$;
 n_{2s} - the number of tandem offices.

Determination of the resultant first kind third order noises W_{31} is considerably more complicated. If it is assumed that the main line will have a straight line frequency phase characteristic, then with analogous designations

$$W_{31m} = n^2 W_{31s}.$$

But the presence of $2n$ sets of directing filters, indefinite number of office and line call loading sets, matching autotransformers and cable inserts on the main line leads to the fact that each specific main possesses a natural, inherent to it, frequency phase characteristic, which without fail deflects from the straight line, and therefore the values of resultant first kind third order non-linearity noises will be contained in the range

$$nW_{31s} \leq W_{31m} \leq n^2 W_{31s}.$$

The resultant power of office noises for all main line at the zero relative level point is obtained by adding separate components.

There are known definite recommendations MKKTT on the noise distribution in aerial main lines multiplexed by 12-channel systems.

In the studied problem, it was suggested to make the total noise power equal to 20,000 μW at the end of a hypothetical 2,500 km long circuit (with three three transducer sections). From this value, 175,000 μW was suggested to set aside for group tandem route noises, which in their turn can be distributed in the following proportion:

Tandem office noises 2,500 μW ;

Transition noises from parallel circuits 10,000 μW ;

Line noises 5,000 μW .

The suggested values are average noise values or busy hour in periods when the line does not undergo the influence of the most unfavorable climate conditions, i.e., approximately in 90% of the time (Red Book Volume I).

Assuming for half of the offices the amplification to be maximum, and for the other half $S = S_m^{-0.4}$ nepers, it can be found using the above expressions^m that the suggested noise value of tandem office equipment equals 2,500 μW , if with the addition of first kind third order non-linearity products $n^{1.13}$ is taken for the lower channel of the lower frequency group and $n^{1.91}$ - for the upper channel of the upper frequency group (other channels of each group will be under more favorable conditions).*

(* With the calculations, an average length of 125 km for the repeater section was assumed; the reception amplifiers of terminal and transducer offices were counted as line repeaters.)

From the obtained results a conclusion can be made, that the magnitude of noises produced by the equipment should be greater in the lower group channels than in the upper group channels. However the measurement experience on the main lines, when the measurement results are determined by line noises, refutes this assumption, and therefore it is advisable to examine the problem on different norms for noise values from transient currents and line noises for upper and lower frequency groups. According to all assumptions for lower frequency group they can

be decreased for the benefit of the corresponding noise increase in the tandem equipment.

6.3 DK-2.8 and BDK-2.8 filters.

Filters DK-2.8 and BDK-2.8 serve to form the order circuit channel in frequency band 300 - 2,400 c in the tandem office. On rack PS there are two DK-2.8 filter sets and two BDK-2.8 filter sets, which permit to form service channels in both directions from the office.

Each set of DK-2.8 filters (Fig. 6.5) consists of low pass filter D-2.8 and high pass filter K-2.8. Both filters are made by a balanced circuit and from the parallel connection side have a compensating circuit L_6C_{14} tuned to 2,770 c frequency.

The filter series branch elements are selected in pairs with very great accuracy in order that the symmetry attenuation would not be smaller than 6 nepers in the pass-band.

Order circuit channel, derived by DK-2.8 filters, is equipped by two-wire low-frequency amplifiers on long main lines. The arrangement of these amplifiers on the circuit is accomplished in such a manner that the places of their location coincide with repeated tandem offices PV-12-2.

In this case for stable operation of two-wire duplex amplifiers, balancing filters BDK-2.8 similar to DK-2.8 filters are connected into the balancing circuits of duplex amplifiers.

On rack PS there are Tr 600/600 transformers, with the aid of which telegraph transmission through Pikar circuit can be organized when distance feeding of office VUS-12 is connected. These transformers are connected at D-2.8 filter input and are designed to pass not only the speaking currents but also the magneto ringing currents.

6.4 Group route equalizers.

These devices serve for the compensation of amplitude frequency distortions, introduced by different group route units. In both group routes the greatest distortions occur at the ends of the operation frequency band; they are caused principally by filters in the route. Analogous distortion character of routes for lower and upper frequency

groups A-B and B-A determines a single form of the equalizer principle circuit (Fig. 6.6a).

Fig. 6.5 Circuit and characteristics of DK-2.8 filters.

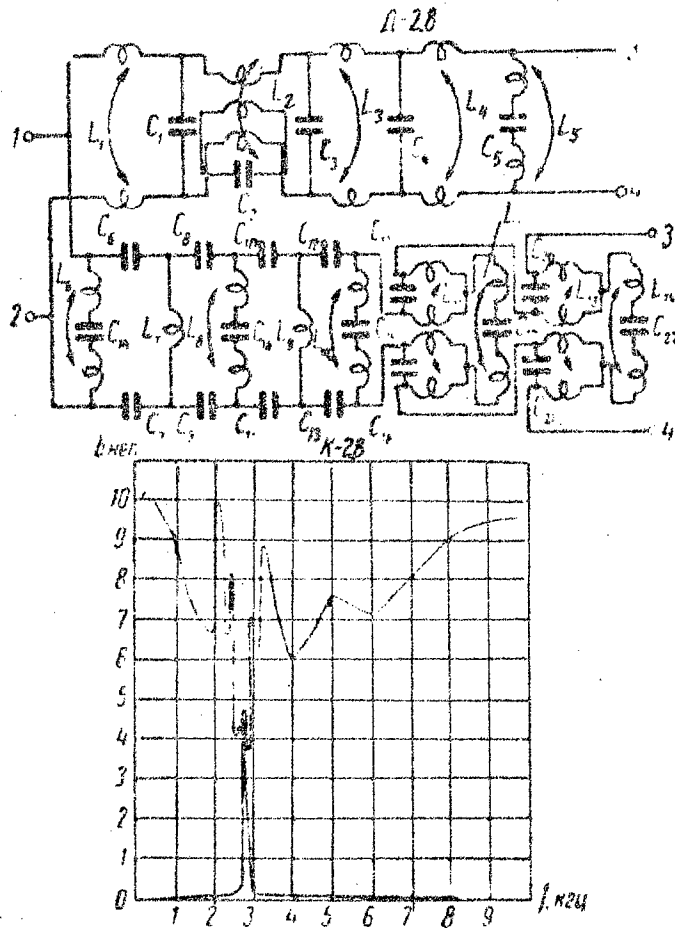

The low-frequency route equalizer differs from the high-frequency route equalizer only by element values.

The attenuation characteristic of low-frequency route equalizer is demonstrated in Fig. 6.6b, and of high-frequency route equalizer on Fig. 6.6c.

Fig. 6.6 Circuit and loss characteristics of B-A and A-B route equalizers.

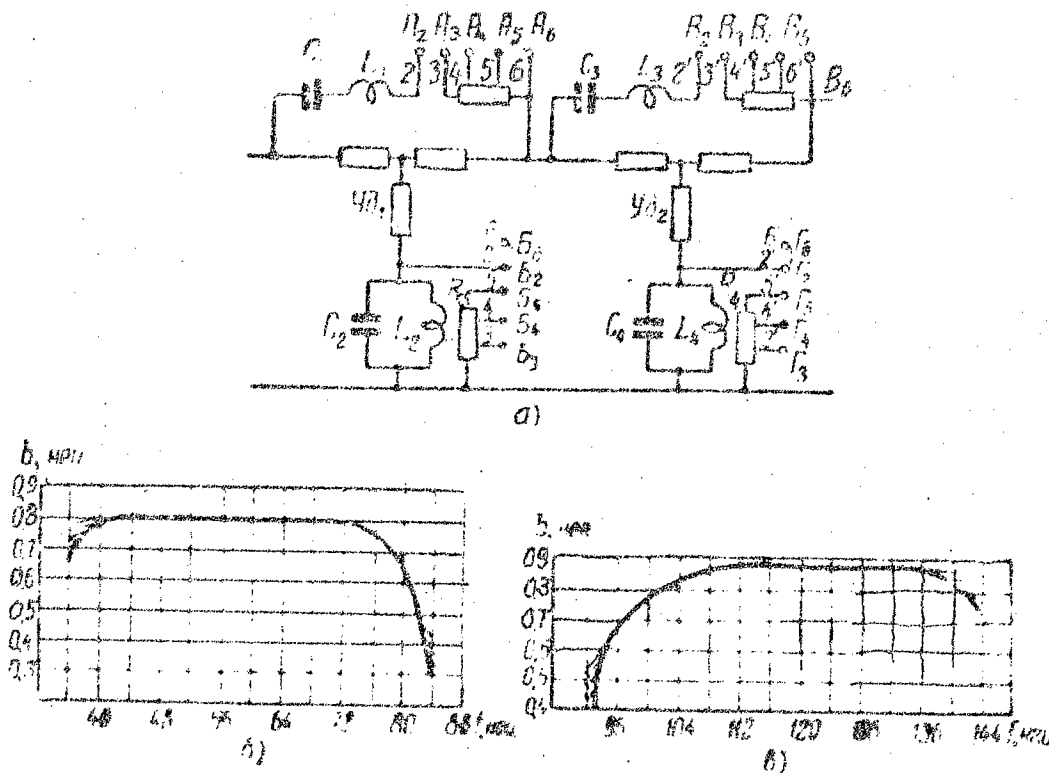

Here, as in the group route equalizers of the terminal office, "fan shaped" characteristics can be obtained at the end frequencies of the operating range with the aid of variable resistors R_2 and R_4 .

A selection of attenuators 0.1 nepers, 0.2 nepers and 0.3 nepers enters into the equalizer block constitution which serve for the establishment of the necessary route amplification when the equipment is tuned. Besides this selection of attenuators, in the low-frequency route equalizer block there are attenuators with attenuations 0.5 and 0.2 nepers, and in the high-frequency route equalizer block - attenuators with attenuations 0.8 and 0.5 nepers.

Attenuators with greatest attenuation are usually connected into both routes and only in some cases, when it is necessary to increase the "flat" route amplification, they are either disconnected or replaced by attenuators with smaller attenuation. The mentioned switchings are

made on the equalizer block cover by bows.

6.5 VK-33 equalizer.

With favorable weather conditions some tandem offices can be disconnected from the main line by forming by-pass circuits (Fig. 2.2). In addition to this, the routes of both transmission directions are completely disconnected, but the line filters remain connected. They introduce additional amplitude frequency distortions, for the compensation of which the VK-33 equalizer is connected into the by-pass circuit. Circuit and characteristic of such equalizer is illustrated in Fig. 6.7.

Fig. 6.7 Circuit and characteristic of VK-33 equalizer.

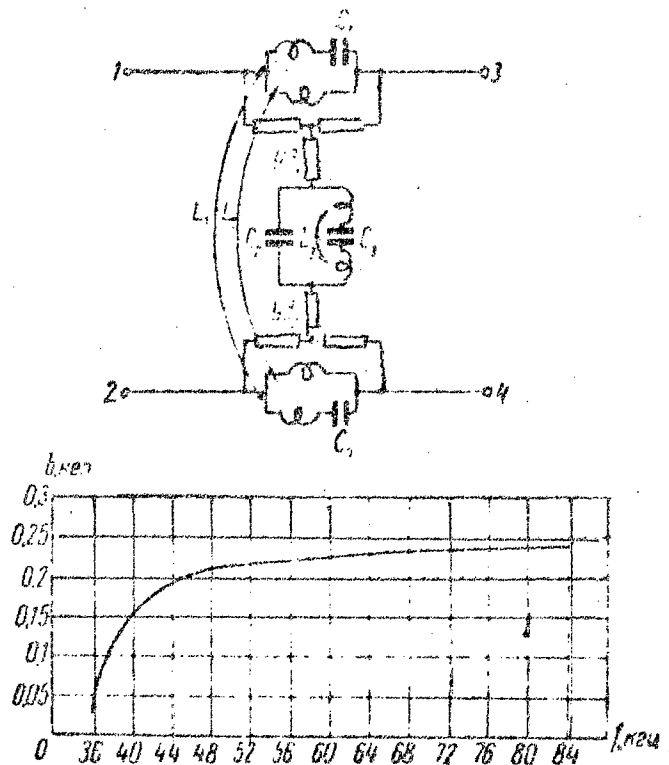

In the operation frequency band from 36 kc and higher the by-pass circuit attenuation is 0.28 nepers, the equalizer corrects the by-pass route with an accuracy of

± 0.05 nepers.

6.6 Speak-buzz device.

A two-wire speak-buzz device PVU enters into the tandem office equipment, and serves for conducting conversation and call through the service channel, formed by filters DK-2.8.

PVU circuit is illustrated in Fig. 6.8. The principle circuit elements are: hand set, consisting of microphone (M) and telephone (T), differential transformer Tr_1 and balancing resistors R_3 and R_4 *, with the aid of (* Resistor R_4 is connected only when conducting common conversation for better balancing of anti-side tone device.) which the anti-side tone device of hand set connection is made, switches Kl_1 and Kl_2 , ringing devices having copper oxide rectifier bridge KM, signal lamp L_2 , load resistors ($R_1 = 2$ kohms and $R_2 = 600$ ohms) and blocking capacitor ($C_1 = 1 \mu f$), which prevents the shunting of the ringing current when connecting PVU in one direction.

Fig. 6.8 Circuit of speak-buzz device (PVU).

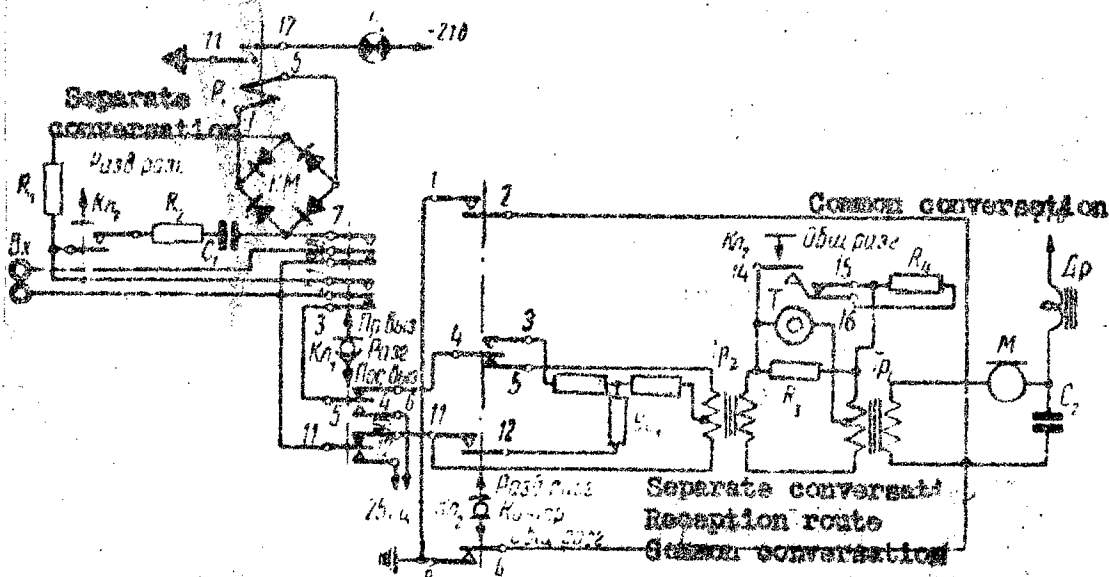

The speak-buzz device permits to accomplish the following operations:

- 1) conducting a separate conversation and call in both directions from the tandem office;
- 2) conducting a common (simultaneous) conversation with neighboring office personnel;
- 3) accomplishment of conversation passage control through the service channel.

Transition to call or control is made by switching of $K1_1$ switch, the sending of the call is accomplished by pressing the key $K1_2$. How to accomplish all these operations, can be easily determined by the above-mentioned circuit. FVU is connected to the line by banana jacks on the FVU block and on the switching board.

Structurally the FVU block is made as a cut in block and is placed on one panel with the switching board.

The switching board is filled with shielded and unshielded jacks, the purpose of which is cleared up when examining the block diagram of PS rack (Fig. 2.2).

Chapter 7. Automatic level regulation (ARU) devices.

7.1 General information.

Attenuation in aerial communication lines depends on whether air temperature, precipitation, i.e., on the entire set of factors called the meteorological conditions. Consequently, to obtain high quality stable communication, it is necessary to install devices into the equipment which would compensate the circuit attenuation variation by regulating the amplification. Without such regulation which is accomplished automatically, ARU, it is impossible to provide high quality continuous communication operation during the entire year in our country with considerable line extensions.

There are some differences from other systems in the ARU device of V-12-2 system. First of all they consist in a somewhat different approach to the determination of limits for flat and especially for the slope regulation.

Operation experience of V-12 equipment showed that it is practically impossible to use maximum amplification of 9 nepers in the tandem offices at frequency 143 kc, since the line noises at such attenuation (9 nepers) of the

repeater section sharply increase. On the other hand, in a number of cases, lack of amplification was noted at frequency 92 kc, which was determined by the extremely large (above 4 nepers) limiting slope of the upper frequency group amplification characteristic.

In V-12-2 equipment the maximum amplification value of tandem offices at 143 kc frequency equals 8.0 nepers. It compensates the attenuation of line section with traverse profile and 4 mm wide diameter, 125 km long with weather conditions "frost 10 mm". * The frequency characteristic (* To maintain communication at glazed frost or more intense frost, offices VUS-12 can be connected between offices PV-12-2.)

of line attenuation at these conditions is given in Fig. 7.1 (curve a). Curve b illustrates the attenuation characteristic of the same section line with meteorological conditions corresponding to minimum circuit attenuation.

Fig. 7.1 Loss characteristic of 4 mm circuit, 125 km long.

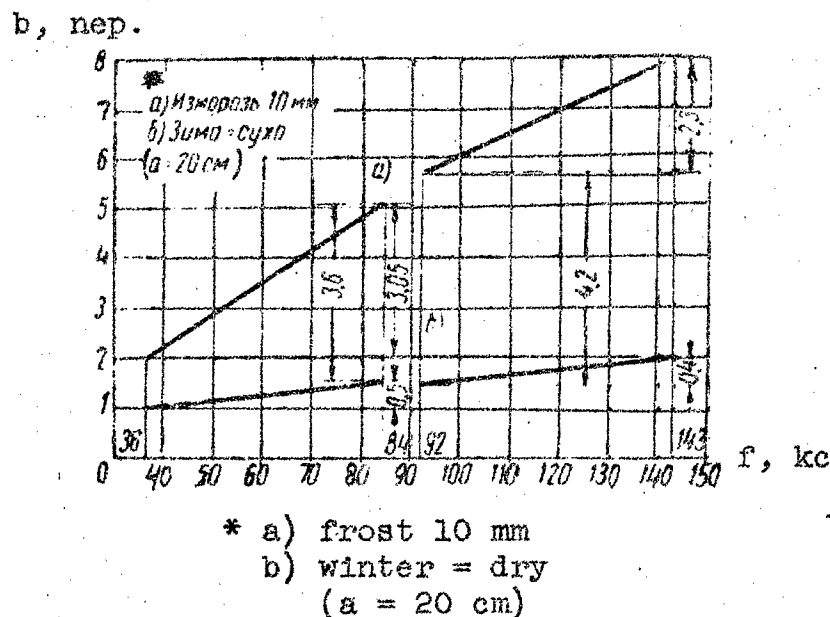

These two characteristics determine the limiting values of tandem office regulation ability. In the low frequency transmission direction, the tandem office

amplification characteristic slope should vary from 0.5 to 3.05 nepers and in the high frequency direction - from 0.4 to 2.3 nepers. With the equipment development this regulation range was somewhat extended to provide a specific margin.

The necessary minimum amplification characteristic slope of the tandem office is reproduced by constantly connected initial slope circuits, which are found in each transmission direction. For low frequency route this slope is 0.5 nepers, and for high frequency route - 0.3 nepers.

The flat amplification variation (regulated by control currents with frequencies 80 and 92 kc) should reach up to 3.6 nepers in the low frequency route and up to 4.2 nepers in the high frequency route. In the equipment this regulation for both transmission directions is accomplished for not less than 5.0 nepers.

To regulate the slope in low frequency route (control current frequency 40 kc) an additional attenuation is introduced at lower frequencies of the transmitted range and in the high frequency route (control current frequency 143 kc) the amplification is increased at upper frequencies.

An electromechanical type two frequency ARU system is used in the V-12-2 equipment.

The amplification regulation principle in this system is the following. The control currents from the output of line amplifiers are selected by narrow band filters and get into the control channel receivers, after amplification and rectification these currents (with deviation of their value from the normal) through tandem relays cause the action of motors turning the capacitance potentiometers. The latter switch over the regulating circuits of artificial lines, as a consequence of which their attenuation changes, and consequently also the route amplification of tandem offices or group reception route of the terminal office. After the changed line attenuation is compensated by changed office amplification, the motors stop.

Principle units entering into ARU equipment are examined below.

7.2 Control channel receiver.

The principle receiver circuit of control channel is given in Fig. 7.2. The control channel receiver contains a narrow band quartz filter, a two-stage amplifier and a rectifier. The performing device in the form of sensitive magnetolectric relay RME-2 is placed on the control ARU panel.

All control channel receivers have similar circuits differing only by some element values.

The amplifier input is separated from filter by a balancing transformer Tr_1 . The control channel filter characteristic is given in Fig. 7.3.

Fig. 7.2 Circuit of the control channel receiver.

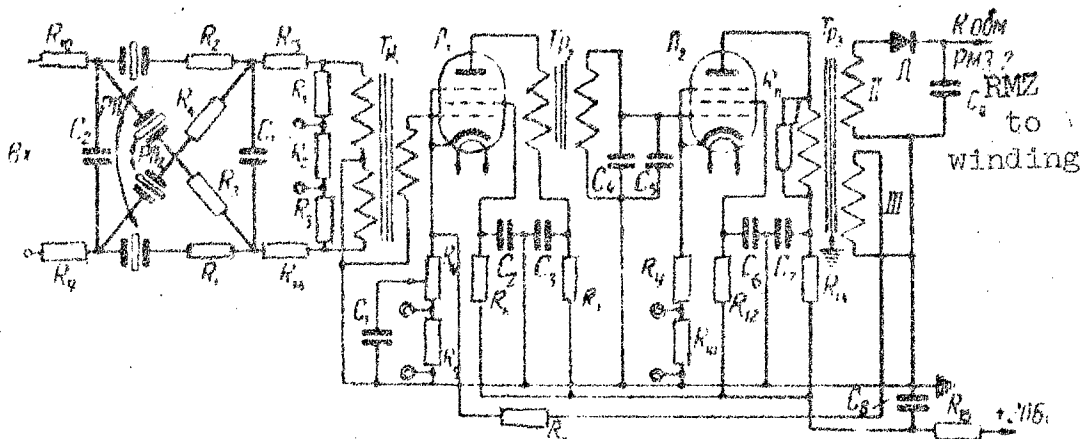

The receiver operation frequency range is determined by the quartz filter passband and by the tuning of circuit $Tr_2 C_4 C_5$. The amplifier feedback depth (winding III of transformer Tr_3 , resistors R_8 and R_4) is not smaller than 3 nepers. The receiver sensitivity regulation in the range ± 0.7 nepers is accomplished by resistor R_4 variation. The second winding of output transformer Tr_3 is connected to a rectifying device, consisting of germanium diode D and capacitor C_9 .

The rectified control frequency current enters, as it was already stated, the magnetolectric relay. At a

nominal control frequency level the current in the relay winding equals 1.05 ma. The relay armature in this case is in the neutral position. The control frequency level variation by ± 0.05 nepers causes a variation of rectified current in the magnetolectric relay winding by ± 0.05 ma, which is sufficient for such relay frame turn, which provides a closing of contacts, and consequently the operation beginning of the entire regulating system.

Fig. 7.3 Control channel filter characteristic.

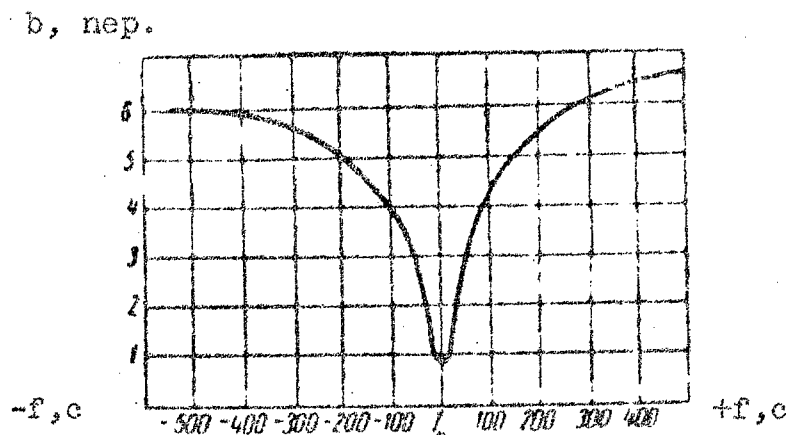

The control channel receivers of the tandem office are connected to the principle transmission route by a special winding of the line amplifier output transformers

Such a connection method is taken because in the PV-12-2 equipment the amplifier output is loaded on the directing filters, made by unbalanced circuit, therefore the control channel filters which are made by a balanced circuit cannot be connected in parallel.

7.3 ARU control panel.

The closing of magnetolectric relay contacts brings into action the entire group of devices and elements. Out of them on the ARU control panel (Fig. 7.4)* (* On Fig. 7.4 only the control of flat regulation is shown. The flat regulation control is constructed

FIG. 7.4 ARU control circuits.

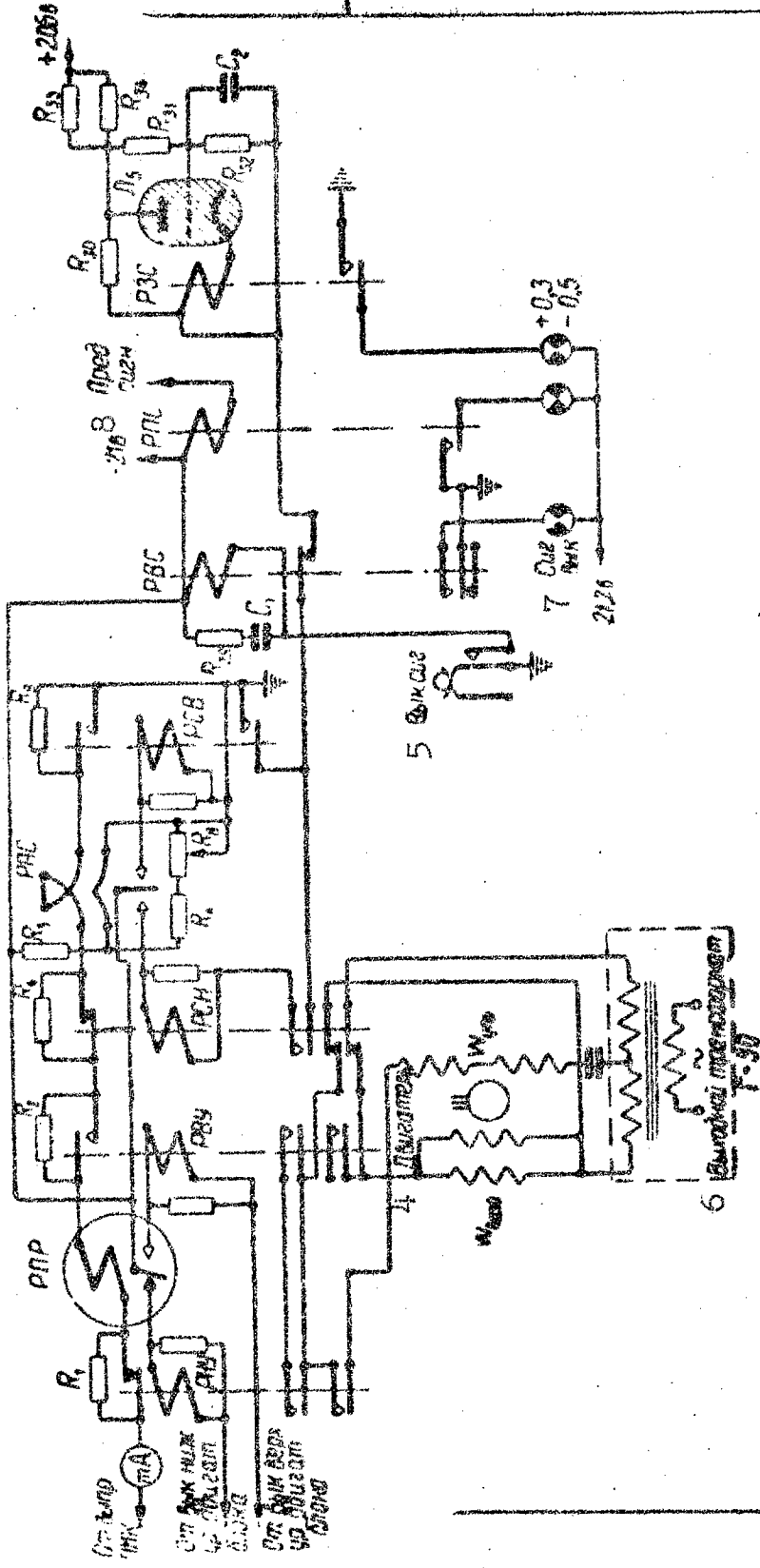

Fig. 7.4 Key

1. From BKK equalizer
2. From lowlevel unit motor switch
3. From upper level unit motor switch
4. Motor
5. Signal switch
6. Output transformer
7. Signal switch
8. Preliminary signal

exactly in the same way, and therefore is omitted from the circuit.)

are placed: magnetolectric relay RPR; relay sets RNU and RVU, which control the switching on and switching off of the flat and slope regulation motors; signal relays RAS, RSN and RSV with lamps, and also level variation indicators. In this circuit magnetolectric relays RME-2 (RPR) are used, which possess stable operation threshold, high sensitivity and maintenance of regulation for a long time.

The control circuit performs the following functions:

1) accomplishes the control of amplification regulation (switching on and off of the motors) with controlled current level oscillations in the range from $+0.05$ nepers and higher and from -0.05 nepers to -0.5 nepers;

2) accomplishes automatic switching on of amplification regulation mechanism in the case if: the control current level decreased by more than -0.5 nepers; the rotors of capacitance potentiometers (switches) reached extreme positions;

3) permits complete manual disconnection for all level regulation devices;

4) turns on the local, the overall rack and overall station emergency signaling with level variations by value equal to or greater than $+0.3$ or -0.5 nepers; this signaling acts with the retardation by 15 to 20 seconds, which is produced by special thyatron circuit;

5) permits to determine approximate magnitude of the relative level variation of control current by indicating devices which have different colored sections on the scale;

6) permits to turn off the emergency signaling with prolonged damage of line or equipment with full restoration of the initial signaling circuit after the emergency is eliminated.

Operation dynamics of control device ARU and the current passage circuit, because of its simplicity, are not examined here.

7.4 Adjusting artificial lines.

Line attenuation is compensated by adjusting artificial lines RIL, which consist of equalizers, capacitors of flat and slope regulations and amplifiers. All this

equipment set is structurally and electrically divided into two parts, of which one provides flat regulation and the other changes the amplification characteristic slope. RIL have different construction for lower and upper frequency groups.

The adjusting artificial lines are made in four forms, which can be denoted: RIL nch pl; RIL nch nakl; RIL vch pl; RIL vch nakl.

All RIL are placed at the beginning of tandem office group routes and terminal office reception routes. The adjusting is accomplished automatically by connecting capacitor blocks* , however manual adjusting is also permitted. (* In multiplexing systems of early productions, units analogous in function were called motor-capacitor blocks.)

We will examine a more complicated circuit - the adjusting artificial lines circuit for the upper frequency group (Fig. 7.5).

Since during unfavorable meteorological conditions the input signal in the upper frequency group has very small level, then to raise the internal noise protection of the station, first of all the level of this signal has to be increased. Following from these considerations, the flat regulation device, which with small signals does not introduce any considerable attenuation, is placed before the slope regulation device and the flat regulation amplifier accomplishes the necessary level increase.

The equipment circuit begins with the attenuator Ud_1 which has an attenuation of 0.3 nepers and is intended to maintain a constant value of the input impedance with different plate positions of flat regulation capacitor KPR. After transformer Tr_1 , which determines together with shunt R_6 the input impedance of RIL, a two-stage capacitance divider is placed, consisting of two series connected two stater differential variable capacitors. The presence of two capacitors with mechanically coupled rotors permits to extend the regulation range. The difference between attenuation values, introduced by these capacitors with extreme rotor positions, is 5 nepers; this essentially determines the flat regulation range. Maximum capacitance of each capacitor equals $60 \pm 10 \mu\text{f}$, and the minimum $7 \mu\text{f}$.

The flat regulation amplifier contains two tubes

Fig. 7.5 Circuit of the h-f route regulating devices.

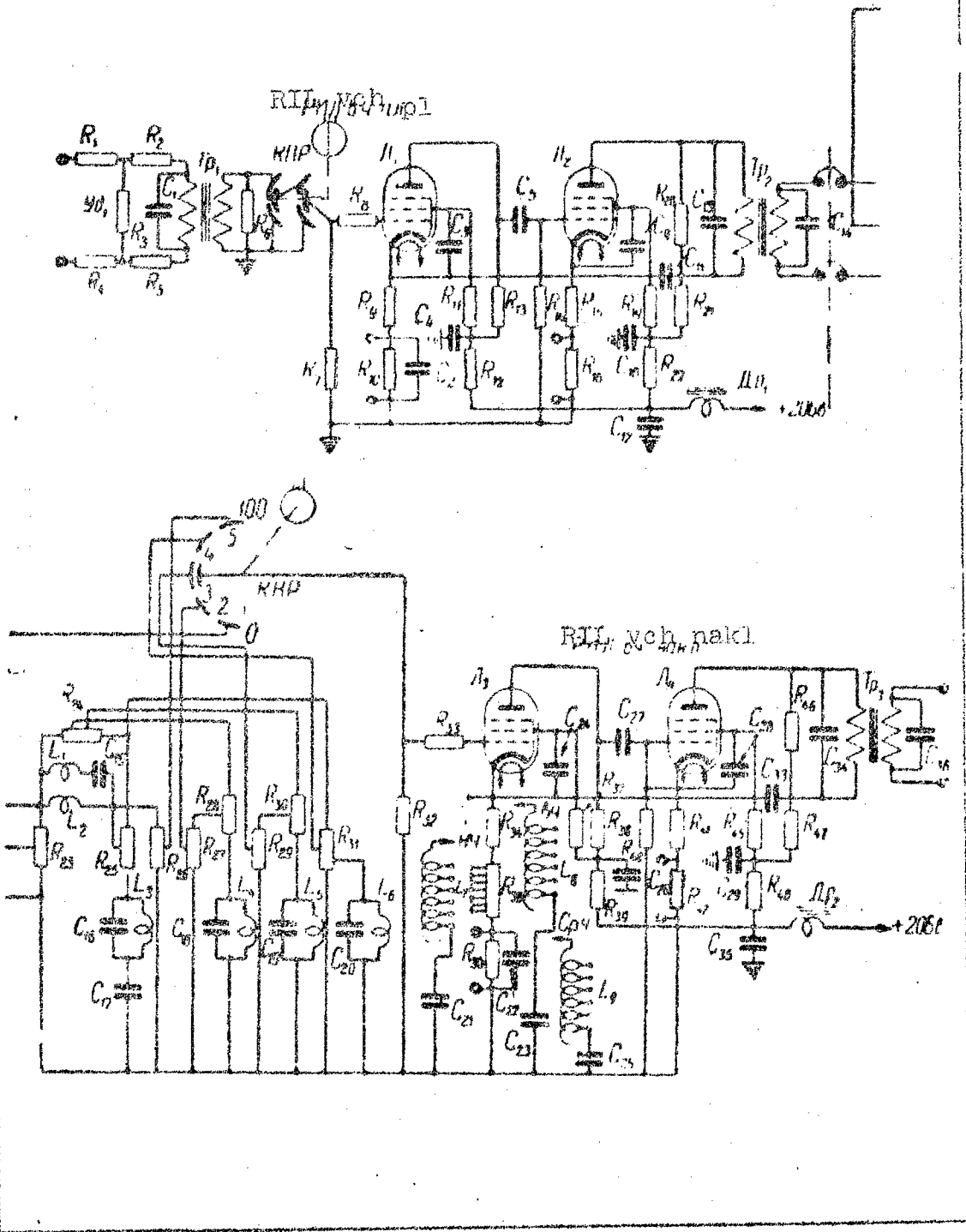

(L_1 and L_2) of type 6Zh1P-E. Its feature is the high input impedance, determined by the leakage resistance of the first two, which is necessary to make for efficient regulator operation. Both amplifier stages are encompassed by the negative current and voltage feedback ($C_{11}R_9$). Output transformer Tr_2 provides the matching of amplifier with load equal to 600 ohms.

The amplifier amplification value should not be large, since overload of the following elements and the amplifier itself cannot be permitted with favorable weather. Therefore it approximately equals 1.7 nepers with feedback the depth of which is 2.8 nepers.

The slope regulation circuit KNR follows after RIL vch pl. Its basis is the L-shaped equalizer consisting of a number of circuits from the elements of which only five branches are made (Fig. 7.6), which lead to the stator sections of capacitor KNR. Two terminal networks, providing the straight line shape of rectifier intermediate attenuation characteristics (Fig. 7.7), are connected to the three center taps. The capacitor KNR rotor, turned by a motor, is connected to slope regulation amplifier, the amplification of which equals 3.4 nepers.

Fig. 7.6 Simplified connection circuit of h-f route slope regulation equalizing circuits.

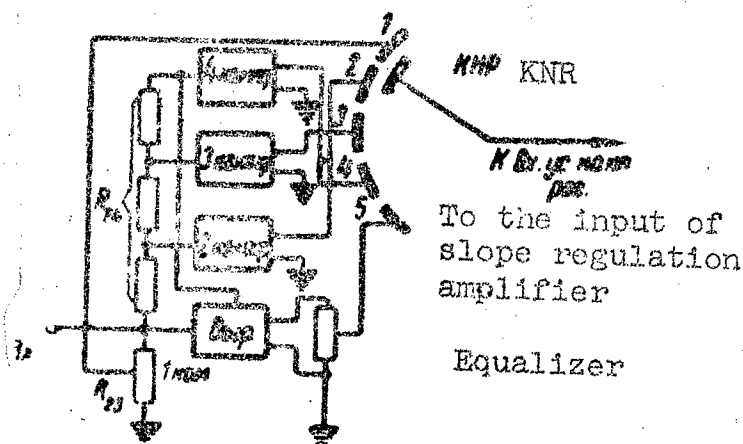

When the rotor passes the intermediate sections from the first section to the fifth, the RIL amplification

characteristic slope changes, reaching a maximum when the difference between amplification values at the end frequencies of the band ($S_{143}-S_{92}$) equals 2.1 nepers.

The effect of slope regulation circuit does not change the amplification for currents with frequency 92 kc. The rate of amplification change with turning of the motor is 0.035 nepers per minute at 143 kc frequency and the passage of rotor from one extreme position to the other takes about 60 minutes.

Fig. 7.7 Loss characteristics of the slope regulation route equalizer.

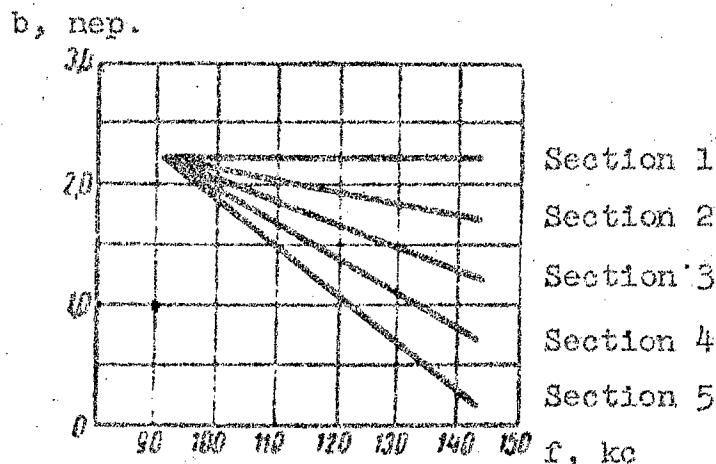

The slope regulation amplifier circuit of high frequency transmission route is similar to flat regulation amplification circuit. The difference is only in the feedback circuit in which there are three correcting circuits (two-terminal networks L_7C_{21} , L_9C_{25} , L_8C_{23}), which permit to correct the constant distortions of the line route at the extreme and at the middle frequencies (Fig. 7.8). Transformer Tr_3 matches the amplifier output with 135 ohm load. With joint action all RIL devices introduce amplification into the high frequency transmission route of the tandem office, the limiting values of which for different frequencies are shown in Fig. 7.9. The numbers on the curves indicate the position of the flat (p) and the slope (n) regulations in the variable capacitors scale

Fig. 7.8 Frequency characteristic compensation in the h-f RIL.

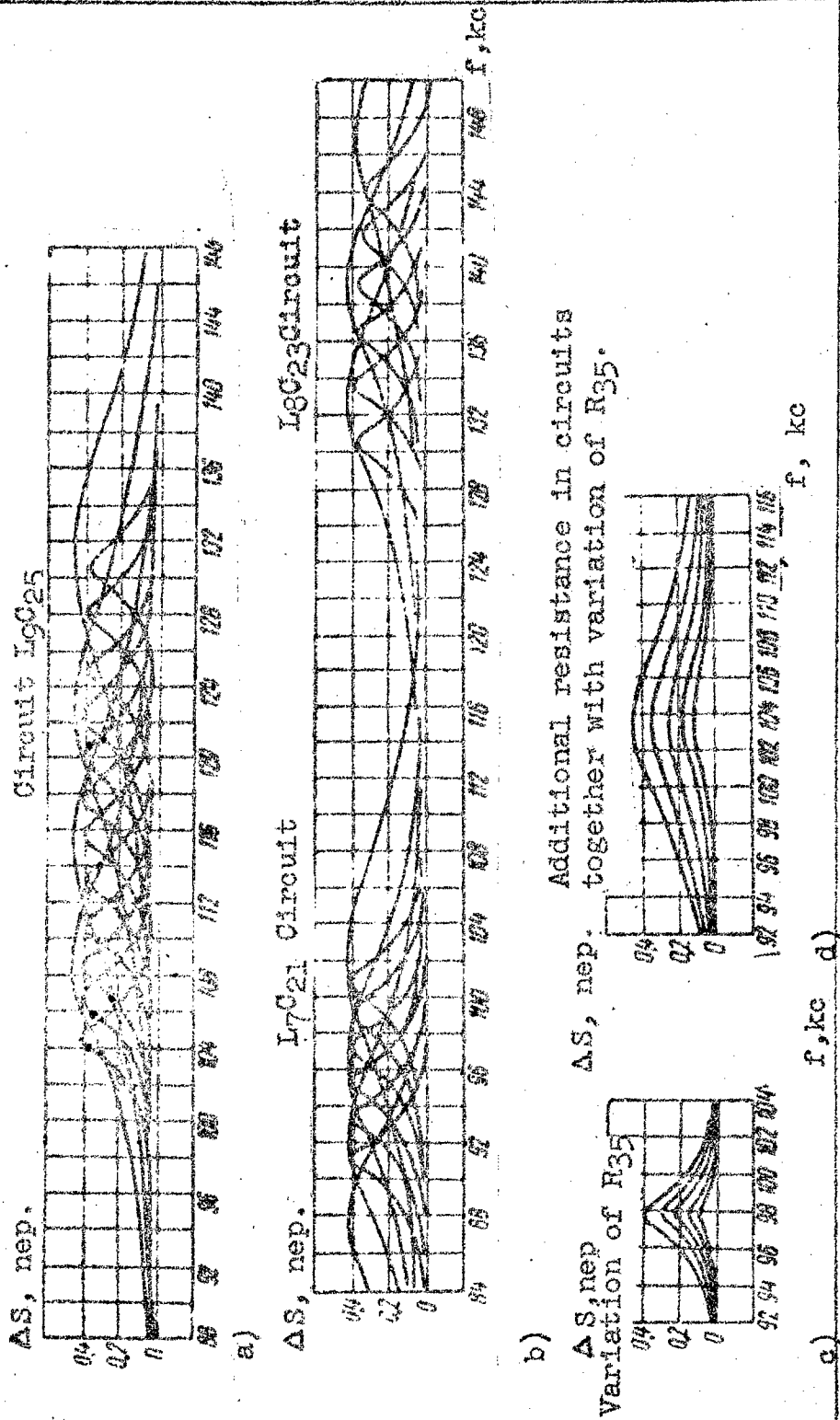

graduations.

RIL for lower frequency group (Fig. 7.10) is made simpler than the above examined RIL vch.

The slope regulator consists of three series connected L-shaped equalizers with taps and seven section variable air capacitor. Since the level at RIL nch nakl input at any weather is not very low, then only one amplifier can be used and KNR should be placed first and then KPR, which requires high resistance load.

Fig. 7.9 Frequency characteristics of h-f route amplification.

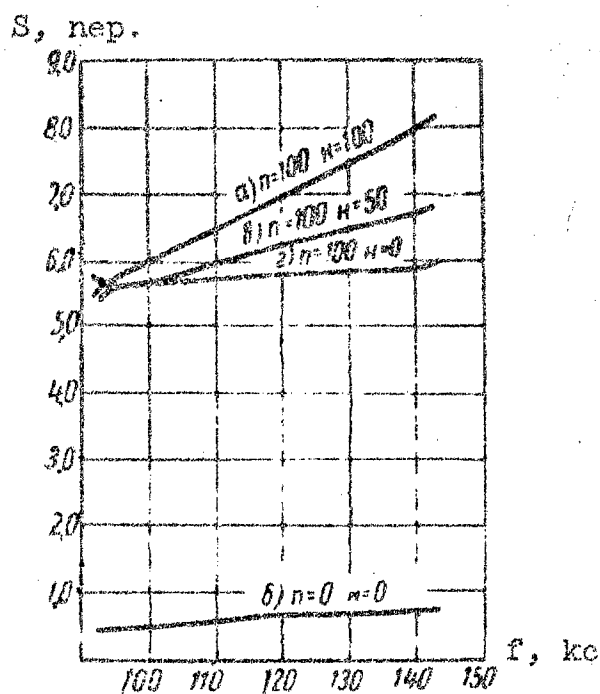

The required attenuation characteristic slope with turning of the capacitor KNR rotor is obtained by summing the attenuations of separate equalizer sections. Each of the three such sections gives a slope to a characteristic, determined by the difference of attenuation values (with frequencies 84 and 36 kc), which equals 1.1 nepers. Thus the maximum slope will be 3.3 nepers.

Seven stater sections of the capacitance switch of

Fig. 7.10 Circuit of e-f controlling devices.

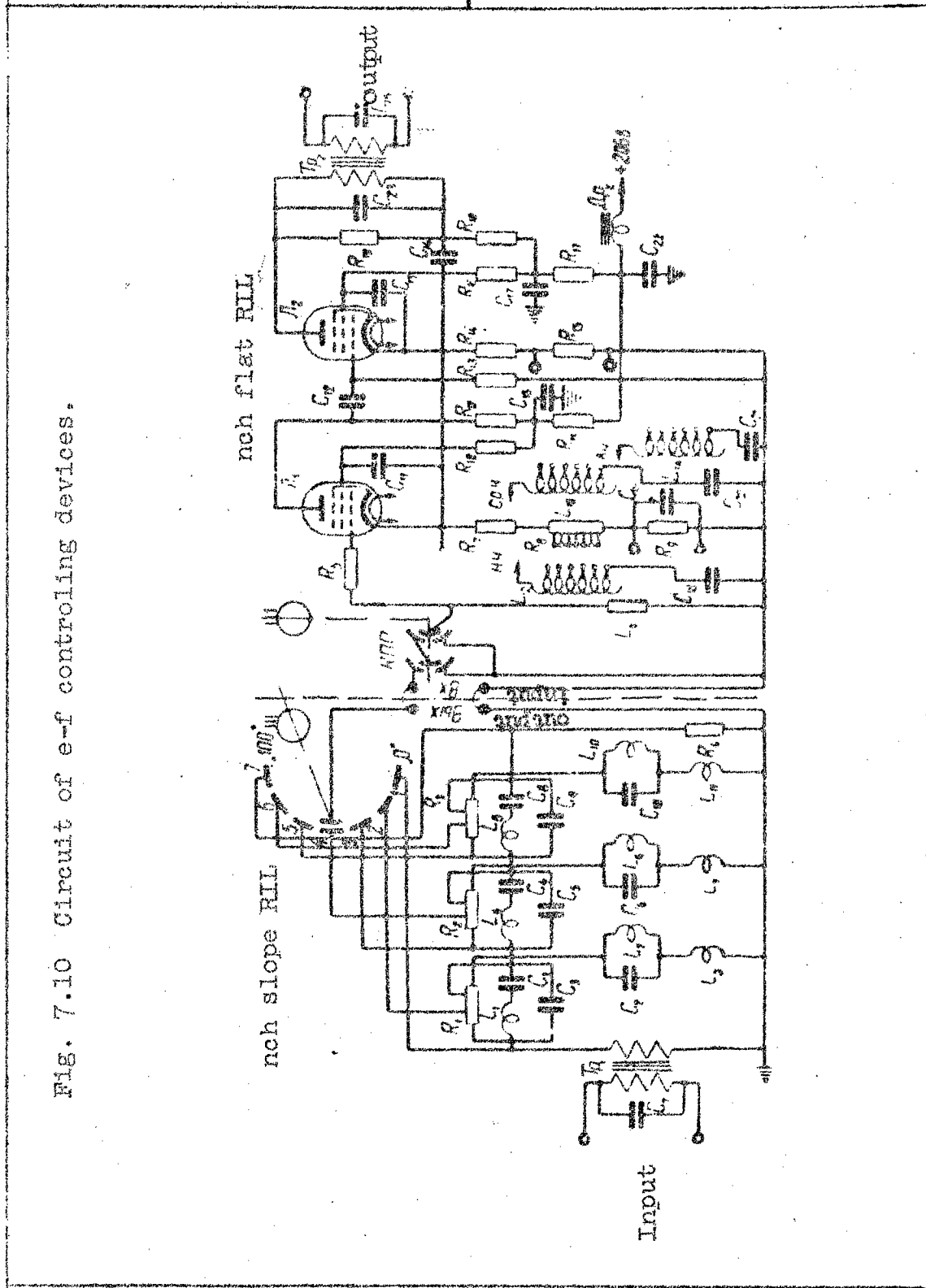

the flat regulation are located in two capacitors, the rotors of which are on one axis, are connected and displaced by the rotor plate width. Taps from the equalizer are alternately connected with the turning of the rotor through the capacitance sections to the output terminals of RIL nch nakl. The rate of slope regulation at 36 kc frequency is on the average 0.073 nepers/minutes.

The flat regulation capacitor KPR is made similar to capacitor KPR in the high frequency route. Its attenuation between extreme rotor positions changes in the range of 5 nepers.

Block RIL nch pl amplifier ($S = 2.9$ nepers) has a circuit analogous to the above examined amplifiers of block RIL pch pl. Elements $L_{12}C_{18}$, $L_{13}C_{20}$ and $L_{14}C_{21}$ are contained in the feedback circuit, intended for the correction of aerial line attenuation characteristic at the ends and at the middle of lower frequency group.

The effect of slope and flat regulation is demonstrated in Fig. 7.11, where the frequency amplification characteristics of the tandem office low frequency route are given with different regulator positions.

Fig. 7.11 Frequency characteristics of e-f route amplification.

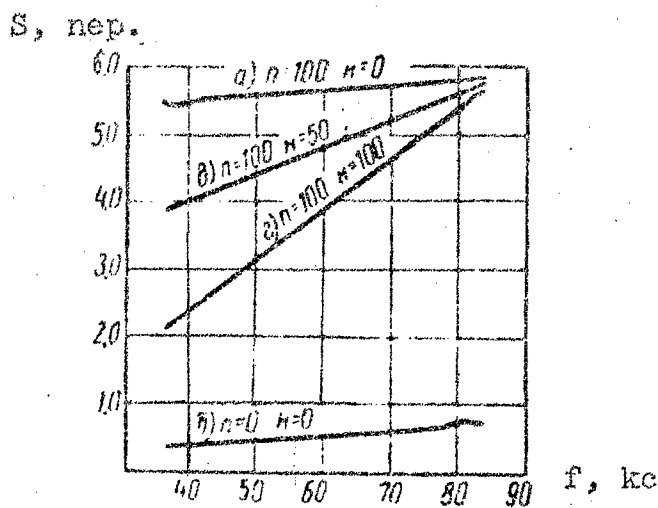

Structurally the RIS panel is divided into two cut in blocks (slope and flat regulation), which are connected to the interpanel cable by 16 contact blocks (for heating and signaling circuit) and by shielded jacks and bows (for high frequency circuits). The blocks include equalizers (in hermetically sealed case), regulated amplifiers and capacitor blocks, which can be easily removed from the common panel. The panel width is 180 mm.

The capacitor blocks installed on the RIL plate, are manufactured in two different structure forms - for flat and slope regulations (Fig. 7.12).

Fig. 7.12 Capacitor units of flat and sloping regulations.

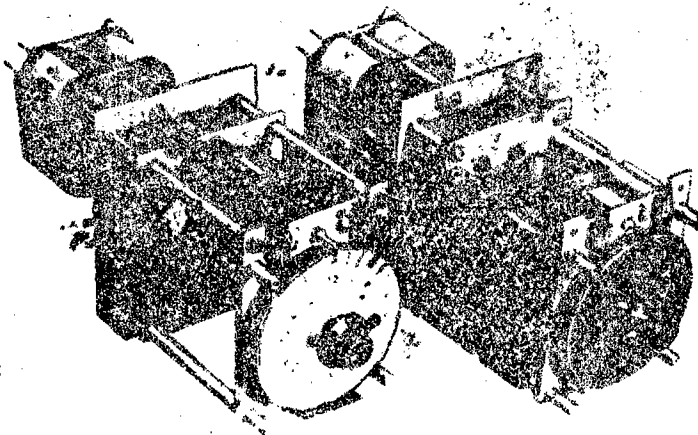

A motor with a reducer (type SD-2, 50 c, 2 revolutions/minute) are placed in the back part of the block. Magnetic system of the motor consists of two winding pairs, displaced in space by 90° . Transformer platss of L-shaped form are used as the core. The block motor is fastened with the capacitors by four columns. The rotation from the reducer is transmitted through two bevel gears and a worm gear to the principle rotation axis of the variable capacitors. The diameter ratio of gear drives provides slowing

down of the rotation speed for the principle capacitor axis 120 times for RIL nch and 240 times for RIL vch with respect to the rotation speed of the reducer axis.

To provide free wheeling, the capacitor rotation axis is set in ball bearings. The further rotation transmission for capacitor blocks of flat and slope regulation is not the same.

The rotors of two sectioned capacitors are directly connected to the axis and have the same speed in the slope regulation capacitor blocks (Fig. 7.12, from the right). In the slope regulation blocks (Fig. 7.12, from the left) there is one more gear drive with 1.4 times slower rotation between this axis and two 2-stater variable capacitors. A disc with graduation from zero up to 100 is fixed to the capacitor rotation axis in front of the block. The highest value of capacitor attenuation corresponds to the zero scale position.

The friction gear in the block provides the possibility of turning the capacitors by hand with the aid of a handle fixed to the end of the axis. In front of the block under the disc, the spring contact groups are installed, which switch over at extreme scale positions, which leads to the turning on of signalization and turning off of the motor.

7.5 50 c Generator.

The 50 c generator (G-50) (Fig. 7.13) feeds the synchronous motors, which turn the regulating capacitor rotors.

The generator has two tubes. The master stage with circuit G_1Tr_1 in the screen grid is made by 6ZHLP-E tube and the amplifier stage by 6P3C-E tube.

The power given off by the output tube into the load (1.6 w) is sufficient for turning four motors at the same time, i.e., all regulators of the tandem office. Disappearance or considerable level decrease of the 50 c frequency current at the amplifier stage output is recorded by signaling acting from a special relay P, which is connected into the simplest rectifier D circuit.

Since there are no high requirements for the generator frequency stability, level stability and for non-linear distortion coefficient, then its circuit does not

have any features worthy of attention, and therefore are not examined here in detail.

Fig. 7.13 Circuit of G-50 generator.

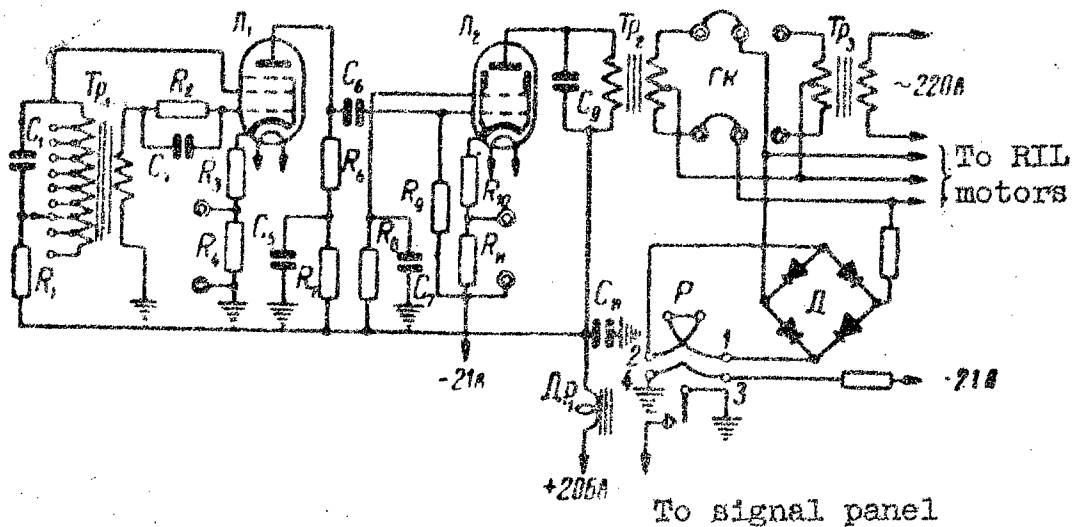

The motors can be also connected to the alternating current grid with voltage 220 volts and frequency 50 c (the generator unit G-50 has a stepdown transformer Tr_3 and a jack lock GK for corresponding switching).

Chapter 8 Apparatus for separating channels.

8.1 General information.

As it was already mentioned in Chapters 2 and 3, the equipment for deriving four channels from the line spectrum of the 12-channel system (Fig. 1.4) is installed in the tandem office, whereupon the routes of derived and through channels are connected in front of the line amplifiers, i.e., after equalizing the frequency characteristics in RIL vch and RIL nch. To accomplish the channel derivation by the assumed circuit turned out to be possible only as a result of the development of low pass and high pass filters (D-68 and K-108).

The attenuation characteristic non-uniformity in

the passband (up to 0.25 nepers) for these filters is increased. Therefore it is undesirable to install the derived channel equipment in several tandem offices in the range of one transducer section. If such an equipment is connected in more than three tandem points, then to correct the distortions at the terminal offices, introduced into the 8 through channel route, is already difficult. The data of these channels will not correspond to the accepted norms.

In Chapter 2 in Fig. 2.3 the measurement level values are given at different route points formed by derived channel equipment. At these levels a normal overall attenuation is provided in the derived channels, which by other data are not different from other channels of V-12-2 system.

Units installed on the derived channel rack SVK can be divided into three groups:

First group - individual equipment units derived from the SIO rack of the terminal office (see Chapter 2). To them relate differential systems with limiters (DSO), individual convertors (M and DM), channel filters (PF), low frequency amplifiers and voice frequency calling-dialing receivers (UNCH-PTNV), relay sets for magneto and voice frequency ringing (RIV and RTV), jacks of two-wire and four-wire switching, voice frequency ringing generator (GTV), neper meter, speak-buzz device (FVU).

Second group - generator equipment units, derived from SGO rack (see Chapter 5). To them relate: the master 4 kc oscillator (G-4), the 4 kc amplifier with harmonic oscillator (Us-4), the separate carrier frequency filters (FI and CH) for the first, second, third and fourth channels.

Third group - units used only in SVK rack. To them refer the route amplifiers of derived channel equipment (Us AB, Us BA, Us AV, Us Vb, Us BV and Us VA), low pass quartz filter (D-68), high pass quartz filter (K-108), group convertors for four channels, low pass filters (D-108), bandpass filter (ZF), control current by-pass filters (FKCH-80 and FKCH-92), the group carrier frequency amplifier (176 kc), the group carrier frequency filter (FGN-176).

Below the construction of units is examined referring the the third group, which do not have similar units

in other forms of V-12-2 system equipment.

8.2 Group amplifiers.

There are six group amplifiers in the derived channel equipment, whereupon two of them are connected into the through channel routes (Us AB and Us BA), and four into the derived channel routes (Us AV, Us VA, Us BV, Us VB). These amplifiers increase the signal level up to a value established by the level diagram.

The amplifier circuits (except Us VB) are similar (Fig. 8.1). They differ only by the construction of output circuits and feedback circuits.

The amplifiers have two stages with tubes 6ZH1P-E. Transformers Tr_1 and Tr_2 are placed at circuit input and output. In Us AB and Us BA the output transformer Tr_2 has four windings. One winding is connected to filter D-68 (or K-108) and thus is in the through channel route. Other winding is connected to filter FKCH-80 (or FKCH-92) and is in the control frequency by-pass route. With the aid of third winding, the feeding of the feedback voltage into the grid circuit of the first stage is accomplished. Amplification of these amplifiers equals 3.5 nepers with feedback, the depth of which is 4.1 nepers.

The relative width of frequency band, is dependent on amplification, and therefore it is not difficult to obtain in it a uniform frequency characteristic (with an accuracy ± 0.03 nepers).

The amplitude characteristic is a straight line up to the level $+2.5$ nepers with accuracy 0.03 nepers. The input and output impedances are not much different from 135 ohms, which provides a reflection coefficient not lower than 10%.

Transformer circuits are simpler in amplifiers Us AV, Us VA and Us BV. They have only three windings, of which one is connected to the external load. Us AV has an amplification of 3.8 nepers with the depth of feedback (OOS) 4.1 nepers. Us BV has an amplification equal to 4.95 nepers with depth OOS 3.5 nepers. Us VA has an amplification of 3.25 nepers with depth OOS 4.2 nepers. All three amplifier types are designed for current amplification in the frequency band 68 to 108 kc. The nominal value of input impedance is 135 ohms. The output

impedance for Us AV and Us BV equals 600 ohms, and for Us VA equals 135 ohms.

Fig. 8.1 Circuit of AB (BA) amplifier.

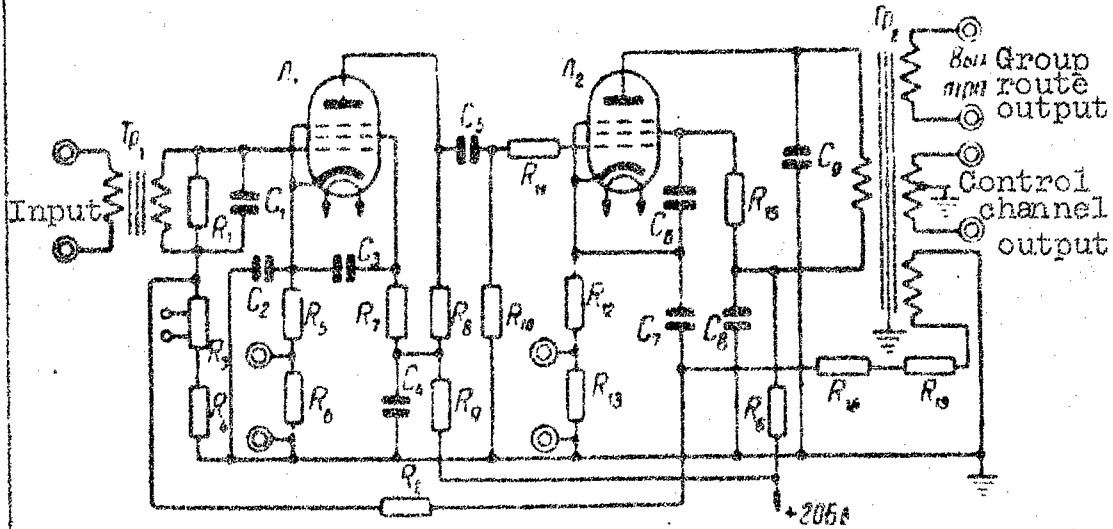
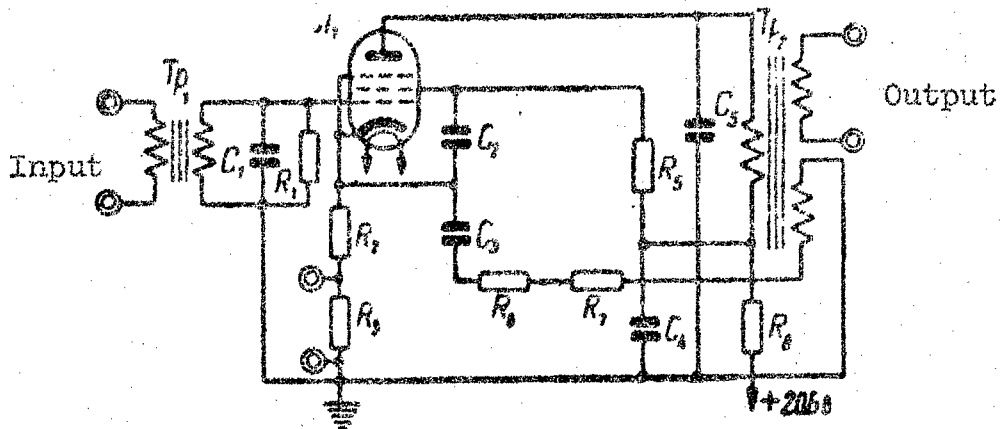

Fig. 8.2 Circuit of VB amplifier.



Amplifier Us VB (Fig. 8.2) has a somewhat different circuit from other amplifiers. It has only one stage with amplification 1.8 nepers. The nominal value of input and output impedance equals 135 ohms.

8.3 Group routes filters.

Low pass and high pass quartz filters (D-68 and K-108) are connected into the routes of eight through channels, passing the currents of frequency band in which they are placed and suppressing currents of the four derived channels. Only the application of quartz resonators in these filters permitted to obtain such a steep attenuation characteristic, that the derivation is accomplished without channel loss. Filter D-68 circuit is shown in Fig. 8.3 and that of filter K-108 on Fig. 8.4.

It is seen from these circuits that each filter consists of two bridge circuit sections and some additional elements. Together with inductors and capacitors, eight quartz resonators are included in the sections. Resistors R_1 to R_8 serve for the balancing of the filter section branches, their value is selected when the filter is tuned.

Attenuators Ud_1 and Ud_2 , connected at the input and output of the filter, are necessary for better matching with load. In filter D-68, there is one more additional section from the input side, which raises its attenuation in the attenuation band. The filters without transformers have input and output impedances in the order 4 kohms; transformers Tr_1 and Tr_2 lower this value to 135 ohms.

Filter attenuation in the passband is not higher than 1.9 nepers and in the attenuation it reaches 9 nepers. This provides a sufficient protection from transient currents between channels.

Natural quartz resonators, inductors with ferrocarr magnetic circuit, capacitors SGM, KPK and KTK are used as filter elements.

Filter D-108 is connected in the route VA and VB, i.e., there where there is group conversion. This filter is connected twice in the BV route (before and after convertor). In the first case it protects route BA from currents with carrier frequency 176 kc, and in the second case (same as in route VA) serves for the derivation of lower side band and for the suppression of unused

Fig. 8.3 Circuit and characteristics of D-68 filter.

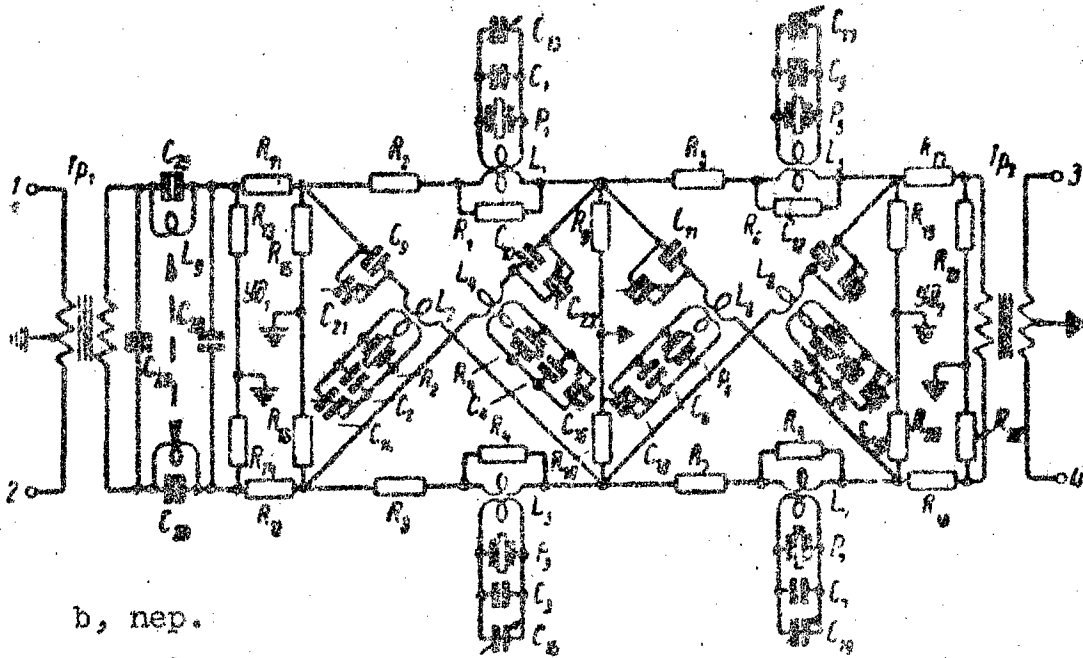

b, nep.

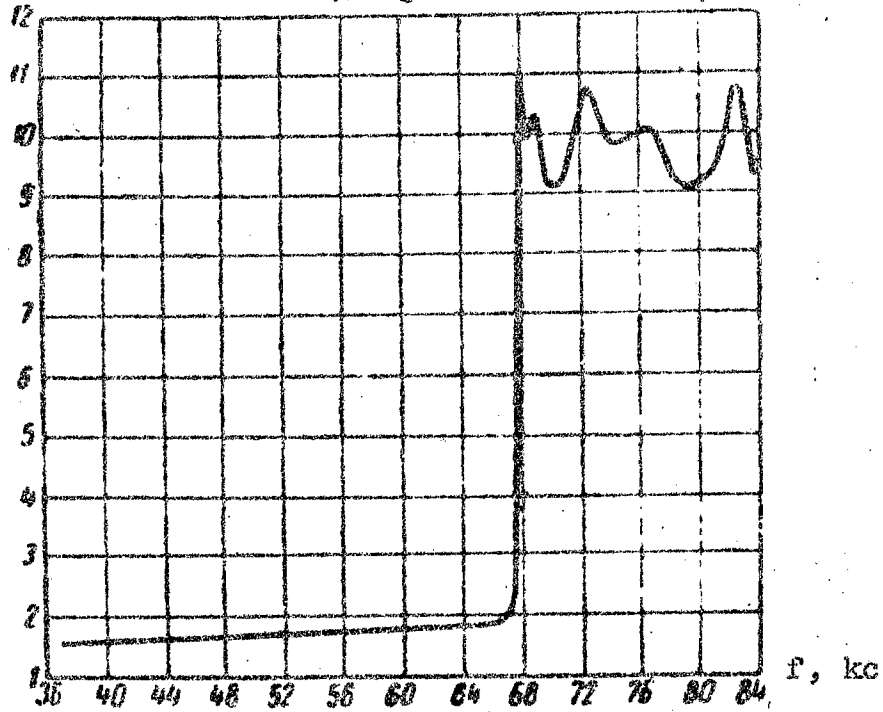
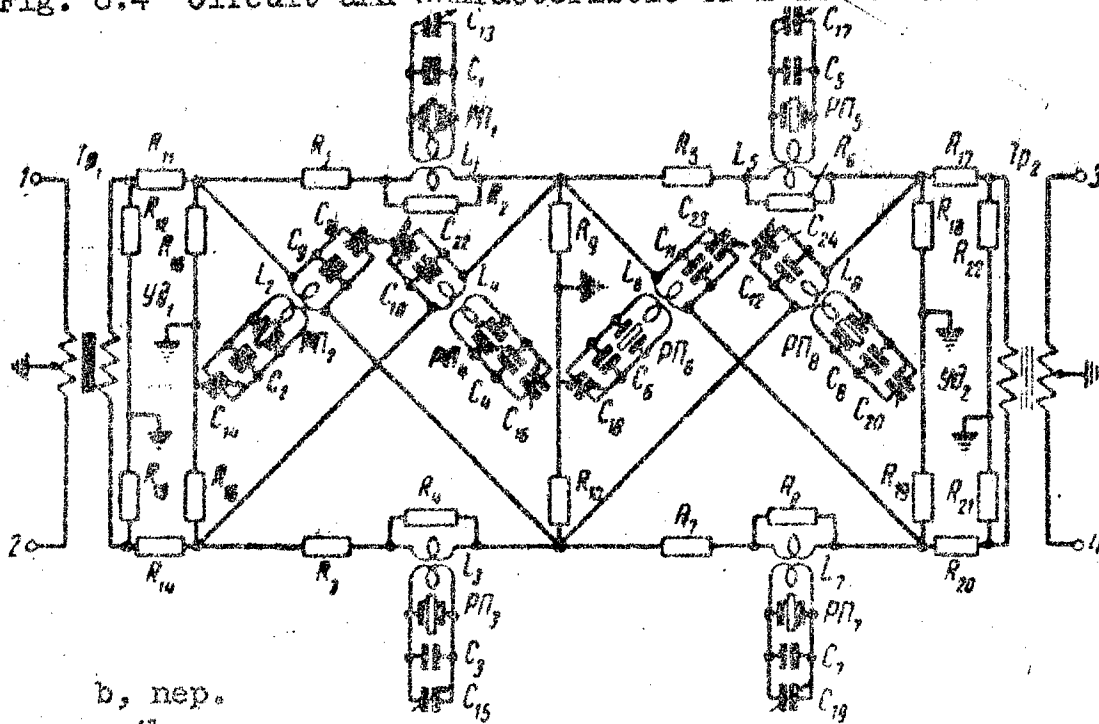
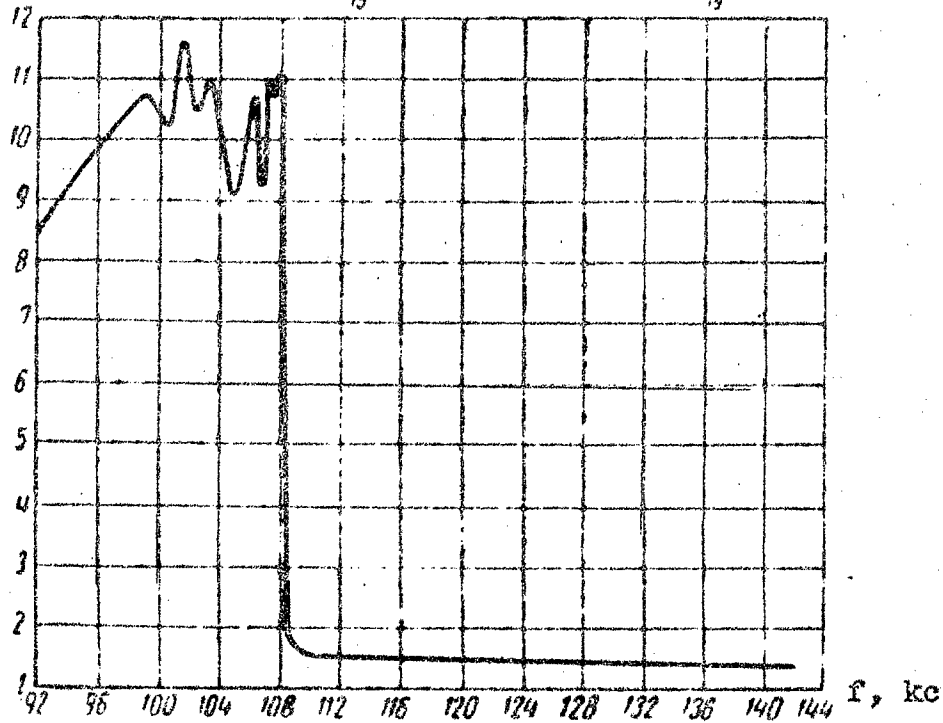

Fig. 8.4 Circuit and characteristic of K-108 filter.



b, nep.



conversion products.

The filter circuit and characteristic are illustrated in Fig. 8.5. It has three sections, whereupon sections are connected at the input and output, which provide better matching with 135 ohm load.

Fig. 8.5 Circuit and characteristic of D-108 filter.

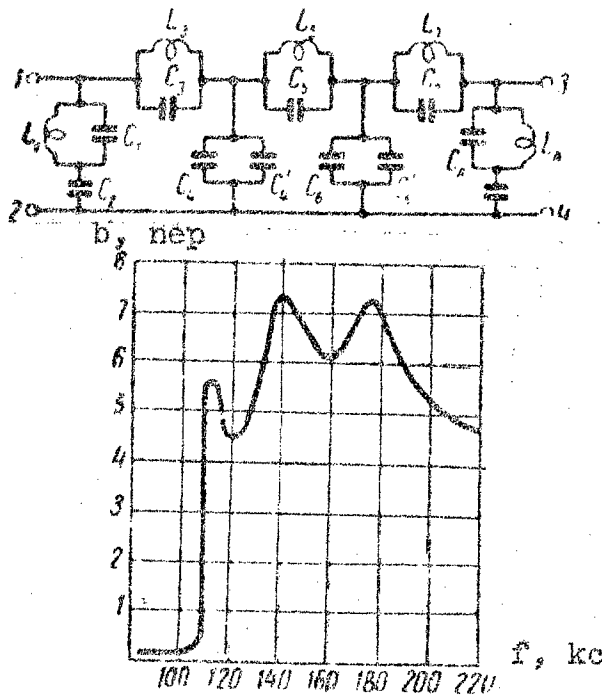

Filter attenuation in the passband is not over 0.5 nepers and in the attenuation band is not lower than 4.5 nepers. Inductors with carbonyl iron cores and mica capacitors SSQ are used as the filter elements.

The units examined above do not exhaust all the original units applied in the rack SVK. However, those which were not described in this section have a great similarity with units already described in other chapters. For example, the group carrier 176 kc frequency amplifier is similar to group carrier 340 kc frequency amplifier (Chapter 5). This can be also said in relation to filter

FGN for the same frequency; the control current by-pass filters FKCH-80 and FKCH 92 are composed of two control channel filters of the tandem office; the band elimination filters ZF (Fig. 8.6) do not differ much from band elimination filters of the terminal office, etc.

Fig. 8.6 Circuit and characteristic of ZF filter for BA route.

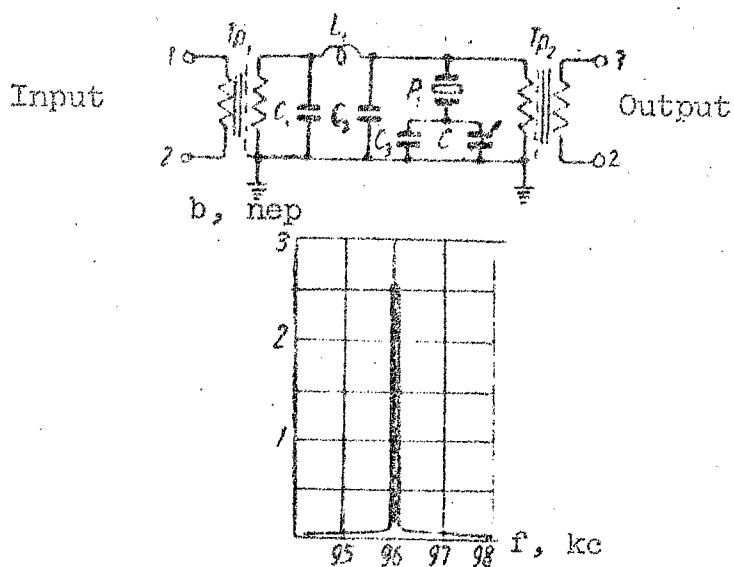

Chapter 9. Some features of equipment operation.

New circuit and structural solutions, used in the design of V-12-2 equipment involve some special features of its operation. First of all it is necessary to point out the new-appearing possibilities of equipment units reservation. The cut-in construction of most blocks permits to have standard emergency blocks and when necessary to replace quickly the damaged block by the reserved. Interchangeability of similar type blocks permits to rearrange them from one position to the other, by this raising the operation flexibility of the equipment; besides that, defect in different devices can be found quickly.

When damage is found or when the units are carefully checked, any block can be taken off the rack and again

connected to it by a hose with blocks. Thus, testing can be made in operating conditions with complete accessibility to the assembly and to the block elements.

Complete set of V-12-2 equipment includes three separate measuring devices. The one most frequently used is the nepermeter, installed on the SIO rack, which gives extensive possibilities for measurements and testing, since its generator and level indicator have improved characteristics and the latter, besides that, an increased sensitivity. The nepermeter is placed closed to the switching board which has jacks that duplicate generator output and level indicator input. Two-wire and four-wire channel output, terminating by separating jacks on the switching board, are mounted in such a way that loading and parallel connection of devices can be made at different points of the low frequency route part. Almost every block in the equipment (or small group of blocks) can be tested separately, because, as a rule, it is included between the separating jacks, which permit parallel connection.

The universal speak-buzz device PVU on racks SIO and SVK, as it was already stated in Chapter 4, can perform many functions, including conversations and calls through channels, connecting and service lines, and also the checking of voice frequency ringing and pulse dialing of sending and receiving devices.

As it is known these devices which connect electromechanical elements (relays) require more frequent checking than others and the presence of a handy device for their control should make easier the keeping of the equipment in good working condition.

The presence of amplifier in the PVU telephone circuit permits to listen in on the noise and interference character in the channels, which sometimes simplifies the finding of interference source. PVU can be connected to the channels through the jacks by cords, in addition to this a separate and common conversation is possible in both directions from the place of PVU connection. The connection with local telephone system is accomplished through service lines independent of the city office type MB, TSB or ATS.

The installation of the testing amplifier on the SIO rack should be referred to the number of additional

facilities provided in the terminal office. Connecting the transmission route output with the reception route input through the testing amplifier, the individual equipment relating to any channel can be checked (Chapter 4, section 10).

The tandem office can also be provided by measuring device UU-15ODP, which is a level indicator and the feeding to which is brought through special jacks (can also be connected in the distance supply stations, e.g., VUS-12).

The operation frequency range of this device is from 0.3 to 150 kc. It measures the level at the office output and other places of the low frequency and high frequency routes in PV-12-2 rack.

A device for testing electron tubes PIEL is also a measuring device, added to the equipment, which measures the cathode activity and cathode currents of the tubes. To accomplish such measurements there are jacks and shunts in the cathode circuit of each tube, and in the heating circuit - jacks and reostats. These and the other elements are placed on the front panel of the blocks.

Terminal and tandem offices of the V-12-2 system contain additional devices, which were not in the equipment set V-12. First, these are the panels with elements providing distance supply feeding to VUS, and second, two filter sets DK-2.8 and BDK-2.8 (only on PS rack). The latter permit to organize a link between operators at low frequency between offices for which on rack PS there is also a two-wire FVU. The organization of such length undoubtedly will raise the quality of main line service.

Arrangement of the equipment units on the racks is made with the consideration of providing minimum inter-rack wiring. Not only the decrease of rack number in the terminal and tandem offices, but also a rational arrangement of the equipment on the racks would make the installation and assembly of equipment in IAZ much easier.

On the lead in terminal blocks placed at the top of the racks, all input and output circuits are looped in which do not require shielding, and large number of shielded circuits are also looped in.

Main fuses for different kinds of feeding are introduced into the rack feeding circuits. This makes it possible to easily and quickly disconnect any voltage from

the rack. When some voltage disappears, the signalling is on. The signalling circuit is made in correspondence with new requirements, as a consequence of which it was possible to apply a single ordinary "transparency" for the entire multiplexing system.

Experimental operation of equipment samples on one of the main lines for one year and some data, obtained by observing system V-12-2 operation in different locations of the country permit to give its characteristic from the point of view of parameter time stability, and also to evaluate measurement methods used during the tuning.

The results stated below were obtained after initial system tuning and after eliminating some defects in the line and in the equipment (the latter sometimes appeared with transportation, rack installation, etc.).

The frequency stability of 4 kc master oscillator fluctuates in the range $2.5 \cdot 10^{-6} \div 4 \cdot 10^{-6}$. The highest transmitted frequency 143 kc varies by 0.3 to 0.5 c, which is not higher than the assigned norm. In conditions of long equipment operation a necessity of fine tuning of the oscillator can arise, since because of the natural aging of quartz resonator the oscillator frequency can deviate from the nominal value. The fine adjustment is made by a variable capacitor (C_3 Fig. 5.2) in the master oscillator circuit, by comparing its frequency with the frequency of other source. Frequency equality for comparison with oscillograph indication is not compulsory, only multiplicity between them is necessary.

Frequency stability of control current independent generators is higher than the standard (standard $2 \cdot 10^{-5}$) and approximately equals $0.7 \div 0.9 \cdot 10^{-5}$. Level variation at 4 kc oscillator output is not higher than ± 0.1 neper, and at the control current generator output not higher than $\pm 0.04 \div 0.05$ nepers.

Fluctuation value of side frequency levels at the output of terminal and tandem offices in time is not over 0.09 nepers and the variation of group route frequency characteristics is in the range 0.1 nepers.

The terminal office set noises for long observation period had the values $0.25 \div 0.50$ mv at the point where the measuring level equals $+0.5$ nepers. Noises are measured at the jack Pr.1in by type UNP-2 sophometer, if

DK-88 racks are loaded by 135 ohm resistance.

On the main line with an extent in the order of 800 km during a half year observation period, the level diagram varied at the points of terminal and tandem office outputs in the range +0.2 to -0.1 neper. Variation of reception levels (overall circuit attenuation fluctuation) for the same time was not higher than ± 0.2 nepers for separate channels and for more than half of the channels ± 0.1 nepers.

A great significance for normal system operation have the maintenance of high degree linearity of the group routes, which can gradually or suddenly decrease because of the tube aging, the variation of resistors and capacitors values, the breaking of contacts, etc.

The amplifier equipment of tandem and terminal offices has great "reserves" in this parameter, as a consequence only prophylactic observation is necessary after the good working condition of the given equipment and the possession of method for fast finding of the defective element.

The measurement of currents of non-linear transitions between channels inside the system is made by using individual equipment. These measurements are made with four-wire connection of channels in the combined frequency of the third order of the form $f_{kom} = f_1 + f_2 - f_3$. Frequencies f_1 , f_2 , f_3 and also channels through which signals with these frequencies are transmitted, are selected in such a way that the non-linearity product in the voice frequency spectrum would have frequency equal to 1,000 c (Table 9.1).

Total voltage (U_{izm}) of combined (U_{kom}) and natural (U_{sh}) interferences is measured at the receiving end of the channel subject to influence. The voltage value of combined frequency is determined from formula

$$U_{kom} = \sqrt{U_{izm}^2 - U_{sh}^2}$$

With increased non-linear transitions, it is necessary to determine the office which is the source of these interferences. The finding of office with increased non-linearity is made by alternately setting the blocking filter, tuned to one of the measuring frequencies.

Trans- mission direction	Linear spectrum alternate	f_1, kc N_{kan}	f_2, kc N_{kan}	f_3, kc N_{kan}	f_{kom}, kc N_{kan}
Top group	I	135/2	95/12	99/11	131/3
	II	136/11	96/1	100/2	132/10
	III	134/11	94/1	98/2	130/10
	IV	137/2	97/12	101/11	133/3
Bottom group	I	77/11	37/1	41/2	73/10
	II	79/2	39/12	43/11	75/3
	III	77/11	37/1	41/2	73/10
	IV	79/2	39/12	43/11	75/3

Table 9.1 Frequencies and channels recommended for the measurement of non-linear distortions by the combined frequency of the form $f_{kom} = f_1 + f_2 - f_3$.

A circuit consisting of series connected inductors and capacitors with very small losses can be used for such a filter. Such a circuit is connected parallel to the tandem office input, and if the non-linearity products disappear when disconnected, then the cause of the increased non-linearity should be looked for in this office. If however, the non-linear transitions do not disappear, then the cause of their appearance should be looked for in another tandem office, closer to that tandem office, from which the measurement signals are applied.

Most tubes 6ZH1P-E and 6P3S-E, used in this equipment, as the experience showed operate more than the guaranteed 5,000 hours and even over 8,000 hours. However 5% of the tubes lose emission before this time and besides that, 3 to 4% of the tubes had to be replaced before their guaranteed lifetime is up for different reasons and mainly because of the increased set noise level, which is more noticeable in UNCH.

Sometimes tubes 6P3S are installed instead of

6P3S-E in some PS and SGO racks. Type 6P3S tubes have a guaranteed lifetime of 500 hours, but practically they work 700-1,000 hours, after which the amplifier non-linearity increases, i.e., tubes gradually go out of order. These tubes should not be left in the operating equipment for a period longer than 1,000 hours. The reserve set of such tubes is twice greater than the usual.

With equipment V-12-2 installation in LAZ containing the equipment of systems V-12 and K-24, a necessity can arise of using the generator equipment of these systems to feed V-12-2 SIO racks by carrier currents. The connection of generator racks of V-12 (SINK) system and K-24 (SNK) system with SIO rack is made in the same way as before with rack SIP of the systems V-12 and K-24.

It is only necessary to disconnect the additional resistances in the distributing device (RU) of SIO and to establish carrier current levels equal to -0.5 nepers (by voltage) at the modulator and demodulator inputs. This recommendation cannot be extended on that small number of SIO racks, which was manufactured with D2V instead of MKV-5-1 diodes in the modulators and the demodulators.

2128

END