

5/23/56
JH
NACA TN 3648

NCAS file copy *7H*

NATIONAL ADVISORY COMMITTEE FOR AERONAUTICS

TECHNICAL NOTE 3648

INVESTIGATION OF BOUNDARY-LAYER TRANSITION ON 10° CONE
IN LANGLEY 4- BY 4-FOOT SUPERSONIC PRESSURE TUNNEL

AT MACH NUMBERS OF 1.41, 1.61, AND 2.01

By Archibald R. Sinclair and K. R. Czarnecki

Langley Aeronautical Laboratory
Langley Field, Va.



Reproduced From
Best Available Copy

Washington
May 1956

DISTRIBUTION STATEMENT A
Approved for Public Release
Distribution Unlimited

20000515 192

100-08-2306

NATIONAL ADVISORY COMMITTEE FOR AERONAUTICS

TECHNICAL NOTE 3648

INVESTIGATION OF BOUNDARY-LAYER TRANSITION ON 10° CONE

IN LANGLEY 4- BY 4-FOOT SUPERSONIC PRESSURE TUNNEL

AT MACH NUMBERS OF 1.41, 1.61, AND 2.01

By Archibald R. Sinclair and K. R. Czarnecki

SUMMARY

An investigation has been made to determine the transition Reynolds numbers on a 10° cone in the Langley 4- by 4-foot supersonic pressure tunnel at Mach numbers of 1.41, 1.61, and 2.01 and over a Reynolds number range from about 0.8×10^6 to 9.5×10^6 per foot. The results indicate that, on the average, the transition Reynolds numbers for a smooth cone increased with tunnel stagnation pressure from about 7×10^6 at a test Reynolds number of 4×10^6 per foot to approximately 8×10^6 at a test Reynolds number of 9×10^6 per foot for all test Mach numbers. There was no effect of Mach number on transition Reynolds number. The results also indicated that the transition point was unsteady and tended to oscillate approximately ± 10 percent about the mean value of transition Reynolds number.

A single-element two-dimensional surface roughness of one layer of 1/2-inch-wide and 0.003-inch-thick cellulose tape caused a larger decrease in transition Reynolds number than was experienced in low-speed or in other supersonic wind-tunnel investigations. The parameter of comparison was the ratio of transition Reynolds number for the rough cone to that for the smooth cone ($R_{t,r}/R_{t,av}$) for the same value of roughness height to boundary-layer displacement thickness at the roughness station (k/δ^*_k).

INTRODUCTION

As part of a general investigation to determine the relative smoothness of the flows in the various supersonic facilities of the National Advisory Committee for Aeronautics (ref. 1), an investigation has been made in the Langley 4- by 4-foot supersonic pressure tunnel to determine the transition Reynolds number for a 10° cone. The tests were made on two solid steel 10° cones, one of which was 10 inches long and the other 24 inches long. Transition Reynolds numbers on the cones were

determined at Mach numbers of 1.41, 1.61, and 2.01 over a Reynolds number range from 0.8×10^6 to 9.5×10^6 per foot. Boundary-layer transition was determined by means of schlieren photographs and cone base pressures. A comparison was made with results obtained in other NACA supersonic facilities. In addition to the tests made on the smooth cones, the effects of wrapping cellulose tape at various distances from the cone apex were investigated.

SYMBOLS

$C_{p,b}$	base pressure coefficient, $\frac{P_b - P}{q}$
p	free-stream static pressure
P_b	base static pressure
q	free-stream dynamic pressure
k	roughness-element height
y	distance normal to surface
δ_k^*	boundary-layer displacement thickness at roughness element, $\delta_k^* = \int_0^{\infty} \left(1 - \frac{\rho u}{\rho_{\infty} u_{\infty}}\right) dy$
ρ	mass density
ρ_{∞}	free-stream mass density
u	velocity
u_{∞}	free-stream velocity
M	free-stream Mach number
R_t	transition Reynolds number for smooth cone, based on free-stream conditions and distance from cone apex along axis to location of transition

$R_{t,av}$	average value of R_t
$R_{t,r}$	transition Reynolds number for cone roughened with cellulose tape, based on free-stream conditions and distance from cone apex along axis to location of transition
R	free-stream Reynolds number per foot
x	distance along cone axis measured from apex
L	length of cone

APPARATUS AND TESTS

Wind Tunnel

The investigation was conducted in the Langley 4- by 4-foot supersonic pressure tunnel which is a rectangular, closed-throat, single-return wind tunnel with provision for the control of the pressure, temperature, and humidity of the enclosed air. Changes in test-section Mach number are obtained by deflecting the top and bottom walls of the supersonic nozzle against fixed interchangeable templates. Tunnel stagnation pressure can be varied from about $\frac{1}{8}$ to $2\frac{1}{4}$ atmospheres.

Calibrations of the flow in the test section indicate that the Mach number variations about the mean value of free-stream Mach numbers are about ± 0.01 in the region occupied by the model and that there are no significant pressure gradients or irregularities in stream flow direction. The turbulence level measured on the center line of the tunnel in the subsonic flow in the entrance cone is presented in figure 1 of reference 2.

Models and Techniques

A sketch of the two solid, highly polished stainless-steel cones is shown in figure 1. The small 10-inch cone was originally made for an investigation in the Langley 9-inch supersonic tunnel. The larger 24-inch cone was constructed in order to obtain transition data at lower values of Reynolds number per foot in the 4- by 4-foot supersonic pressure tunnel. The total cone angle of each cone was 10° . The cones were carefully polished and cleaned prior to each run. The root-mean-square surface roughness of the two cones was estimated to be 5 to 6 microinches or less.

A strain-gage type of pressure transducer unit was used to measure the difference between model base pressure and free-stream pressure. One side of the unit was connected to a group of tunnel static orifices, and the other was connected to a small tube leading up to the base of the cone on the outside of the sting.

For this investigation, the schlieren system was adjusted so that the knife edge was horizontal (parallel to the air flow). Sample schlieren photographs are shown in figure 2. In figure 2(a), the rearward portion of the 24-inch cone is shown with a fully laminar boundary layer. In figure 2(b), transition occurs upstream of the base; the transition point on the lower surface is marked by an arrow. In this photograph, the boundary layer on the upper surface is not visible. In general, however, transition could be identified on both cone surfaces on the original negatives.

Tests

Tests were made with the models alined to within 0.1° of the tunnel axis. The two cones were tested in the smooth condition at Mach numbers of 1.41, 1.61, and 2.01. In addition, the 24-inch cone was tested at the three Mach numbers with a single-element two-dimensional roughness strip consisting of a 1/2-inch-wide band of 0.003-inch-thick cellulose tape placed around the cone at various distances ranging from about 4 to 12 inches from the cone apex. Similarly, the 10-inch cone was tested at $M = 1.41$ with the roughness strip located from 2 to 6 inches from the apex. Variations in Reynolds number per foot were obtained by varying the tunnel stagnation pressure. Tunnel stagnation temperature varied from about 90° F at the lower pressures to about 130° F at the higher pressures but did not change appreciably with time while data were being taken. Because of this small stagnation-temperature change with time and because of the length of time allowed before data were taken, it is believed that the heat transfer was essentially zero.

RESULTS AND DISCUSSION

Smooth Cone

The transition Reynolds numbers obtained on the smooth cones by the schlieren technique at Mach numbers of 1.41, 1.61, and 2.01 are shown in figure 3(a) for the 24-inch cone and in figure 3(b) for the 10-inch cone. No transition results for the 10-inch cone are available at $M = 2.01$ because the maximum Reynolds number per foot that could be obtained at this Mach number were too low to fix transition on the model. The dashed lines in the figure correspond to the Reynolds number at the base of the

two models at the particular value of R , or the maximum value of R_t attainable. Arrows on the test points indicate that transition was off the model; hence, R_t could not be determined but is known to be higher than the value indicated.

The results shown in figure 3(a) indicate a considerable amount of scatter (on the order of ± 10 percent). This scatter results primarily from the fact that the transition point is unsteady and is continuously oscillating back and forth over a limited Reynolds number range. A similar unsteadiness of transition was found in the tests reported in reference 3 and the possible reasons for this unsteadiness have been discussed in considerable detail in reference 4. Some of the scatter at high values of R at $M = 1.41$ (the generally low values of R_t) may be due to sandblasting of the model with a resultant roughening of the model surface. In general, when sandblasting effects were known definitely to be present, the data have been omitted. Also within this range of high values of R , the schlieren photograph often showed turbulence bursts well ahead of the main transition front. These bursts have been neglected.

As the tunnel stagnation pressure was increased (increase in R), the transition Reynolds number increased. (See fig. 3(a).) On the average, the increase in R_t for the 24-inch cone was from approximately 7×10^6 at $R = 4 \times 10^6$ per foot to approximately 8×10^6 at $R = 9 \times 10^6$ per foot. These values are considerably higher than obtained for a 10° cone in most other facilities. (See ref. 1.) This increase was the same at all Mach numbers since the data showed little or no effect of Mach number. For transition at the base of the model, which corresponds in figure 3(a) to the intersection of the band of data points with the dashed lines, the average transition Reynolds numbers as determined by changes in base pressure were in good agreement with the average values indicated by the data obtained by schlieren photography.

A comparison of the results obtained on the 10-inch cone (fig. 3(b)) with those of the 24-inch cone shows that the values of R_t for the shorter cone are somewhat lower than those of the longer cone at the same values of R . A comparison of the transition Reynolds numbers for the two cones for transition occurring at the base indicates the values to be about equal. These rather contradictory results may have been caused by the fact that the tip of the 24-inch cone was somewhat sharper than that of the 10-inch cone; also, the data are rather meager for the 10-inch cone and lie in a region where sandblasting effects may be present. Hence, it appears doubtful that any conclusions are justified.

A comparison of the transition results for both cones of the present investigation with those obtained on the identical 10-inch cone in the Langley 9-inch supersonic tunnel is presented in figure 4. It should

be noted that the investigation in the 9-inch supersonic tunnel was not as extensive as that in the 4- by 4-foot supersonic pressure tunnel. A strong Mach number effect on transition is shown by the results obtained in the 9-inch supersonic tunnel but this effect is nonexistent in the results obtained in the 4- by 4-foot supersonic pressure tunnel. At the same value of R , the present results are somewhat higher than those of the 9-inch supersonic tunnel, particularly at Mach numbers greater than 1.6. The reason for this discrepancy is not known. The fact that at $M \approx 1.6$ and $R = 9 \times 10^6$ per foot the transition Reynolds numbers for the 10-inch cone are approximately equal, whether tested in the 9-inch supersonic tunnel or the 4- by 4-foot supersonic pressure tunnel (compare fig. 3(b) with fig. 4), probably has little significance in view of the discrepancies in trends existing at the other Mach numbers. Figure 4 also indicates that the transition Reynolds numbers obtained from the investigation made in the 4- by 4-foot supersonic pressure tunnel as well as those obtained in the 9-inch supersonic tunnel are considerably higher than the transition Reynolds numbers obtained from the various wind-tunnel investigations of reference 1.

Cone With Roughness

The transition data obtained by schlieren photography for a cone with a roughness consisting of a single thickness of 1/2-inch-wide and 0.003-inch-thick cellulose tape attached to the cone at various axial stations indicated an excessive amount of scatter, and, hence, are not presented. The average transition Reynolds numbers for transition near the model base, as determined by changes in base pressure, showed somewhat less scatter and are plotted in figure 5 as the ratio $R_{t,r}/R_{t,av}$ against roughness location x/L . The expression $R_{t,r}/R_{t,av}$ is the ratio of transition Reynolds number for the rough cone to the average transition Reynolds number for the smooth cone at the same value of tunnel Reynolds number per foot. The method of estimating $R_{t,r}$ from the increase in base pressure coefficient following a negative pressure peak is illustrated in figure 6. Values of transition Reynolds numbers determined by this procedure were in good agreement with the average values determined by means of schlieren photographs.

The comparison of transition Reynolds numbers for the rough and smooth cones was made at constant R because this method insures identical boundary-layer characteristics ahead of and at the roughness strip. Because transition was determined at the base of the cone with the roughness strip installed, transition for the smooth cone would occur off the model at the same value of R and could not be determined directly. The transition Reynolds number for the smooth cone was, therefore, obtained for the same value of R from an average curve drawn through the schlieren data points in figure 3. The use of this procedure corresponds to

the assumption that the variations in transition Reynolds number with changes in tunnel pressure are due to tunnel effects. If the variation is due to some model effect, it would be more logical to use for R_t the value obtained at the point corresponding to that used in determining transition for the model with roughness - that is, at the model base. In any case, the difference is very small.

The results presented in figure 5 show considerable scatter but appear to indicate a logical trend in that the closer to the cone apex the surface roughness occurs, the greater is the decrease in transition Reynolds number. For the 24-inch cone with the roughness strip at $x/L = 0.17$, the transition Reynolds number was decreased to approximately 50 to 60 percent of the value obtained on the smooth cone at the same R . For the 10-inch cone with the roughness strip at $x/L = 0.20$, the transition Reynolds number was decreased to approximately 30 percent. No Mach number effects were apparent although the scatter is fairly large and may mask such trends. The curve for the shorter cone is steeper, of course, because the roughness strip is relatively thicker for this cone, by 2.4 times relative to cone length, than for the longer one.

In order to determine whether the transition for the two cones would correlate on a boundary-layer-thickness basis, the results of figure 5 have been replotted in figure 7 as a function of k/δ^*_k . The boundary-layer displacement thickness was computed for the proper Mach number and temperature relationships by the flat-plate method of Chapman and Rubesin (ref. 5) and the use of Mangler's transformation (ref. 6). The data were also compared with the average results obtained at low speeds as compiled in reference 7. The comparison indicates that the single-element roughness studied in this investigation caused earlier transition in terms of the boundary-layer displacement thickness at the roughness station than occurred in the low-speed investigation. This trend is contrary to that normally experienced in other supersonic investigations, for instance those discussed in reference 8. The trend may be partly explained by two factors. First, the reference transition Reynolds numbers for the smooth cones in this investigation were higher than in the low-speed or other supersonic investigations; thus, it was possible that the laminar boundary layer was more sensitive to roughness than it would be at lower Reynolds numbers. Second, since the present results for the smooth cone do not show the decrease in the transition Reynolds number with Mach number that most other supersonic facilities do, the expected favorable effect of M on $R_{t,r}/R_{t,av}$ may not be realized.

SUMMARY OF RESULTS

An investigation has been made to determine the transition Reynolds numbers on a 10° cone in the Langley 4- by 4-foot supersonic pressure tunnel at Mach numbers of 1.41, 1.61, and 2.01 and over a Reynolds number range from about 0.8×10^6 to 9.5×10^6 per foot. The results indicate the following:

1. On the average, the transition Reynolds numbers for a smooth cone increased with tunnel stagnation pressure from about 7×10^6 at a test Reynolds number of 4×10^6 per foot to approximately 8×10^6 at a test Reynolds number of 9×10^6 per foot for all Mach numbers.
2. There was no effect of Mach number on transition Reynolds number.
3. The transition point was unsteady and tended to oscillate approximately ± 10 percent about the mean value of transition Reynolds number.
4. A single-element two-dimensional surface roughness caused a larger decrease in transition Reynolds number than was experienced for the same value of roughness height to boundary-layer displacement thickness at the roughness station in low-speed or in other supersonic wind-tunnel investigations.

Langley Aeronautical Laboratory,
National Advisory Committee for Aeronautics,
Langley Field, Va., January 30, 1956.

REFERENCES

1. Ross, Albert O.: Determination of Boundary-Layer Transition Reynolds Numbers by Surface-Temperature Measurement of a 10° Cone in Various NACA Supersonic Wind Tunnels. NACA TN 3020, 1953.
2. Czarnecki, K. R., and Sinclair, Archibald R.: Preliminary Investigation of the Effects of Heat Transfer on Boundary-Layer Transition on a Parabolic Body of Revolution (NACA RM-10) at a Mach Number of 1.61. NACA TN 3165, 1954. (Supersedes NACA RM L52E29a.)
3. Evvard, John C., Tucker, Maurice, and Burgess, Warren C., Jr.: Transition-Point Fluctuations in Supersonic Flow. Jour. Aero. Sci., vol. 21, no. 11, Nov. 1954, pp. 731-738, 748.
4. Schubauer, G. B., and Klebanoff, P. S.: Contributions on the Mechanics of Boundary-Layer Transition. NACA TN 3489, 1955.
5. Chapman, Dean R., and Rubesin, Morris W.: Temperature and Velocity Profiles in the Compressible Laminar Boundary Layer With Arbitrary Distribution of Surface Temperature. Jour. Aero. Sci., vol. 16, no. 9, Sept. 1949, pp. 547-565.
6. Schlichting, Hermann (J. Kestin, trans.): Boundary Layer Theory. McGraw-Hill Book Co., Inc., 1955, p. 168.
7. Dryden, Hugh L.: Review of Published Data on the Effect of Roughness on Transition From Laminar to Turbulent Flow. Jour. Aero. Sci., vol. 20, no. 7, July 1953, pp. 477-482.
8. Brinich, Paul F.: Boundary-Layer Transition at Mach 3.12 With and Without Single Roughness Elements. NACA TN 3267, 1954.

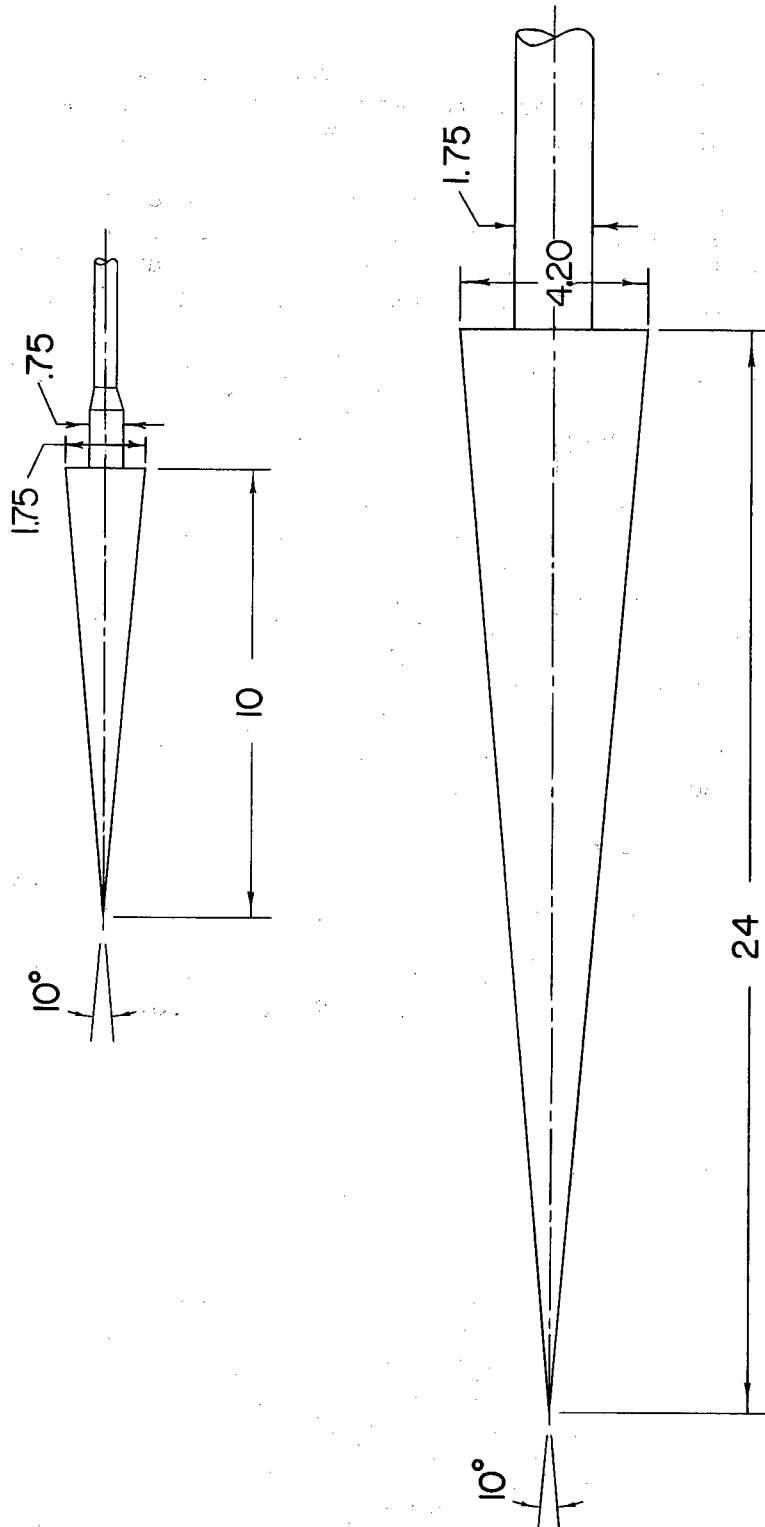
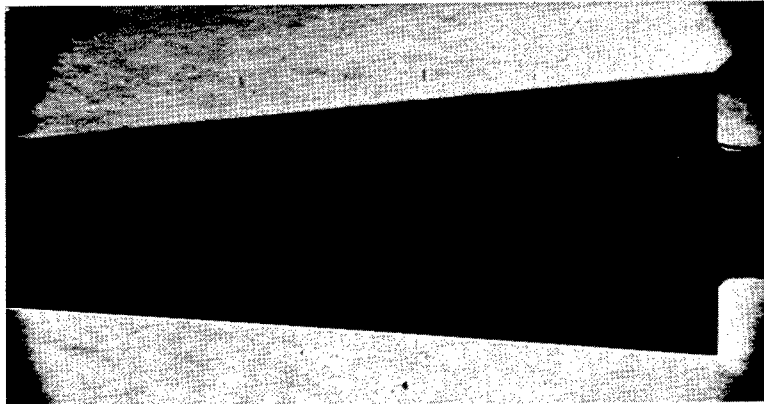
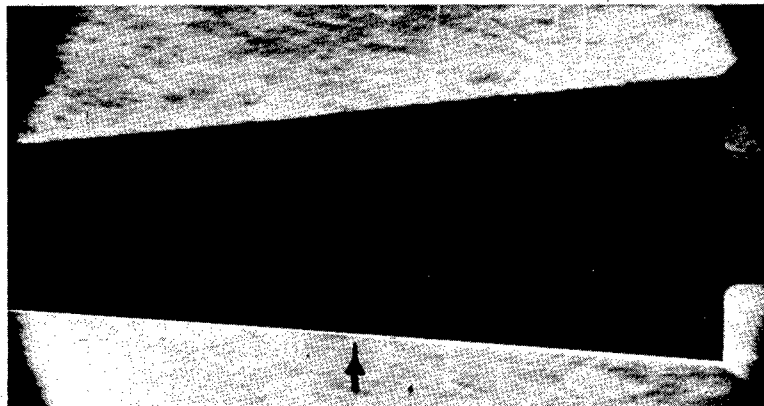

Figure 1.- Sketch of 10° cones. All dimensions are in inches.



(a) Laminar; $R = 3.35 \times 10^6$ per foot.



(b) Transition; $R = 4.43 \times 10^6$ per foot. L-91766

Figure 2.- Schlieren photographs of 24-inch cone showing fully laminar boundary layer and boundary layer with transition. $M = 1.61$; horizontal knife edge.

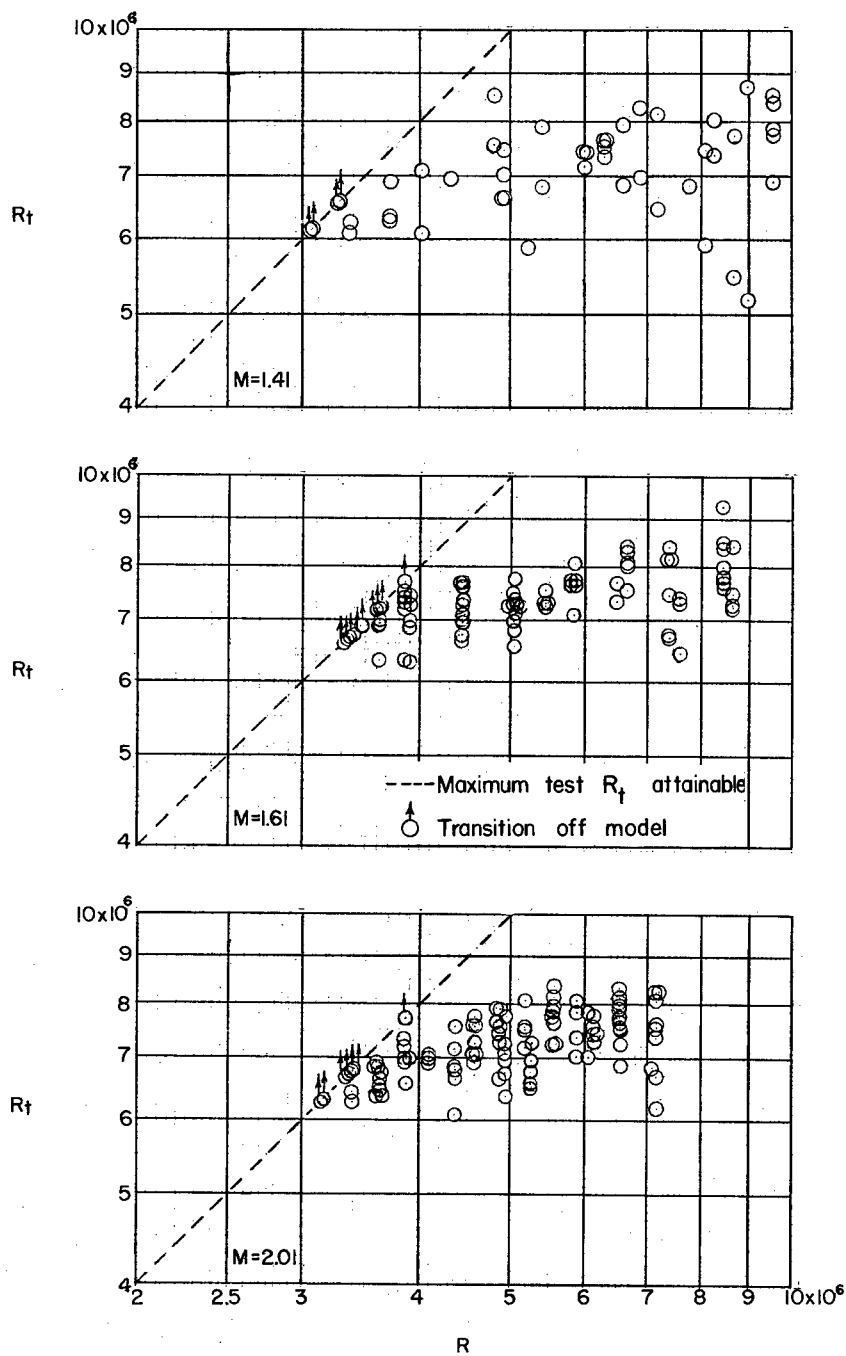

(a) 24-inch cone.

Figure 3.- Variation of transition Reynolds number with Reynolds number per foot. Data obtained by schlieren technique.

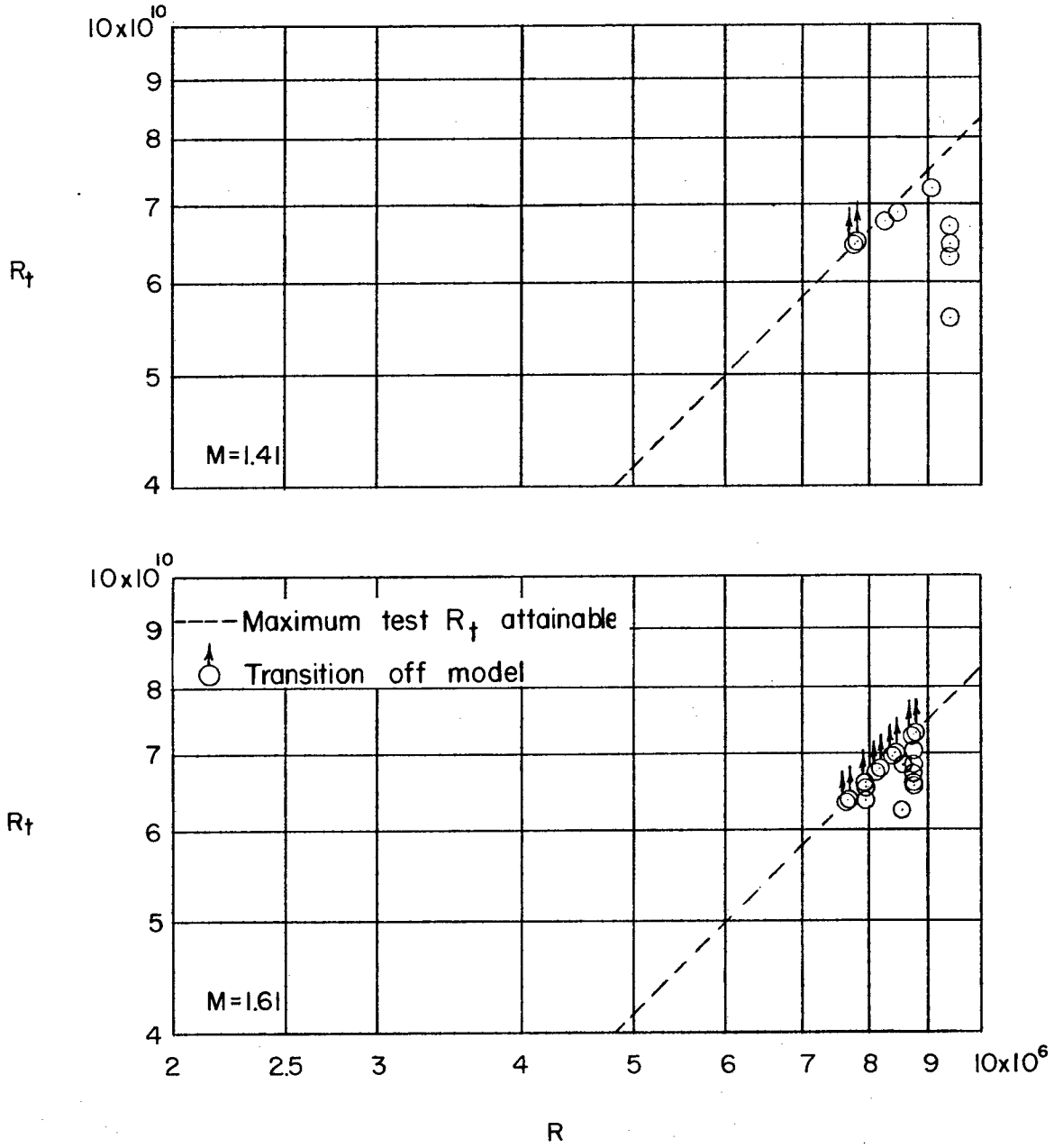

(b) 10-inch cone.

Figure 3.- Concluded.

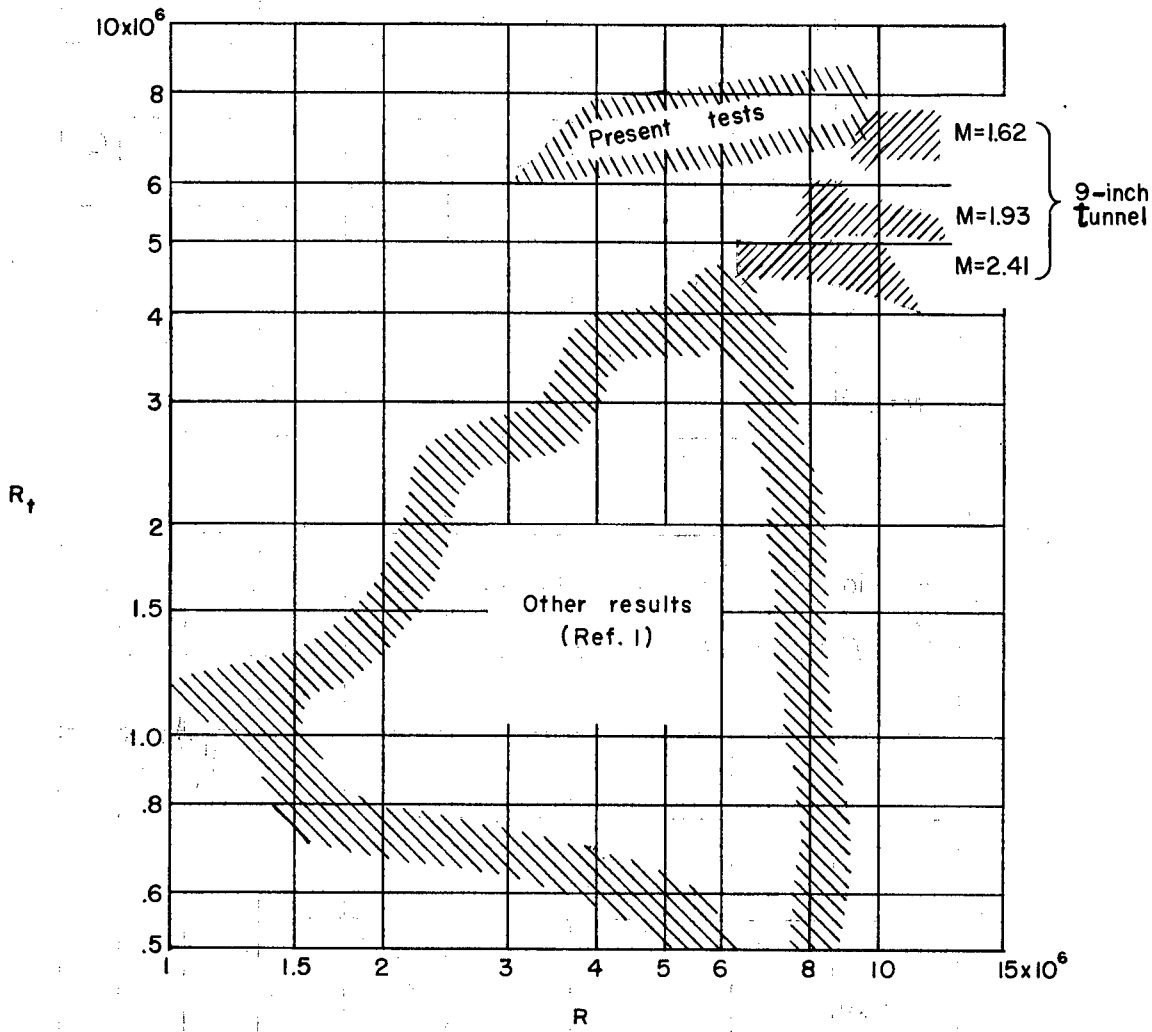

Figure 4.- Comparison of results of present cone tests with those obtained in the Langley 9-inch supersonic tunnel and with results compiled in reference 1.

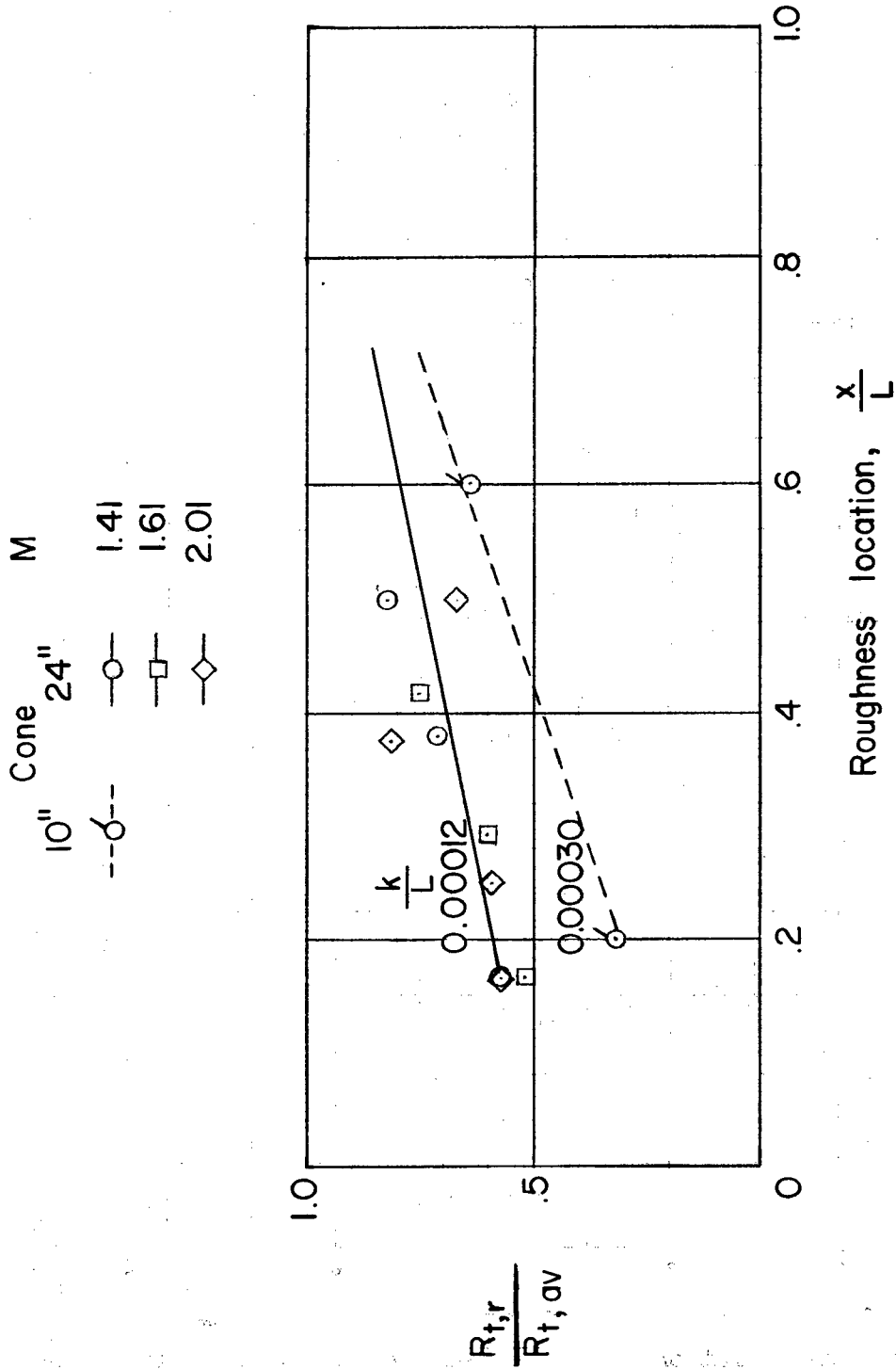

Figure 5.- Variation of transition Reynolds number ratio $R_{t,r}/R_{t,av}$ with roughness location.

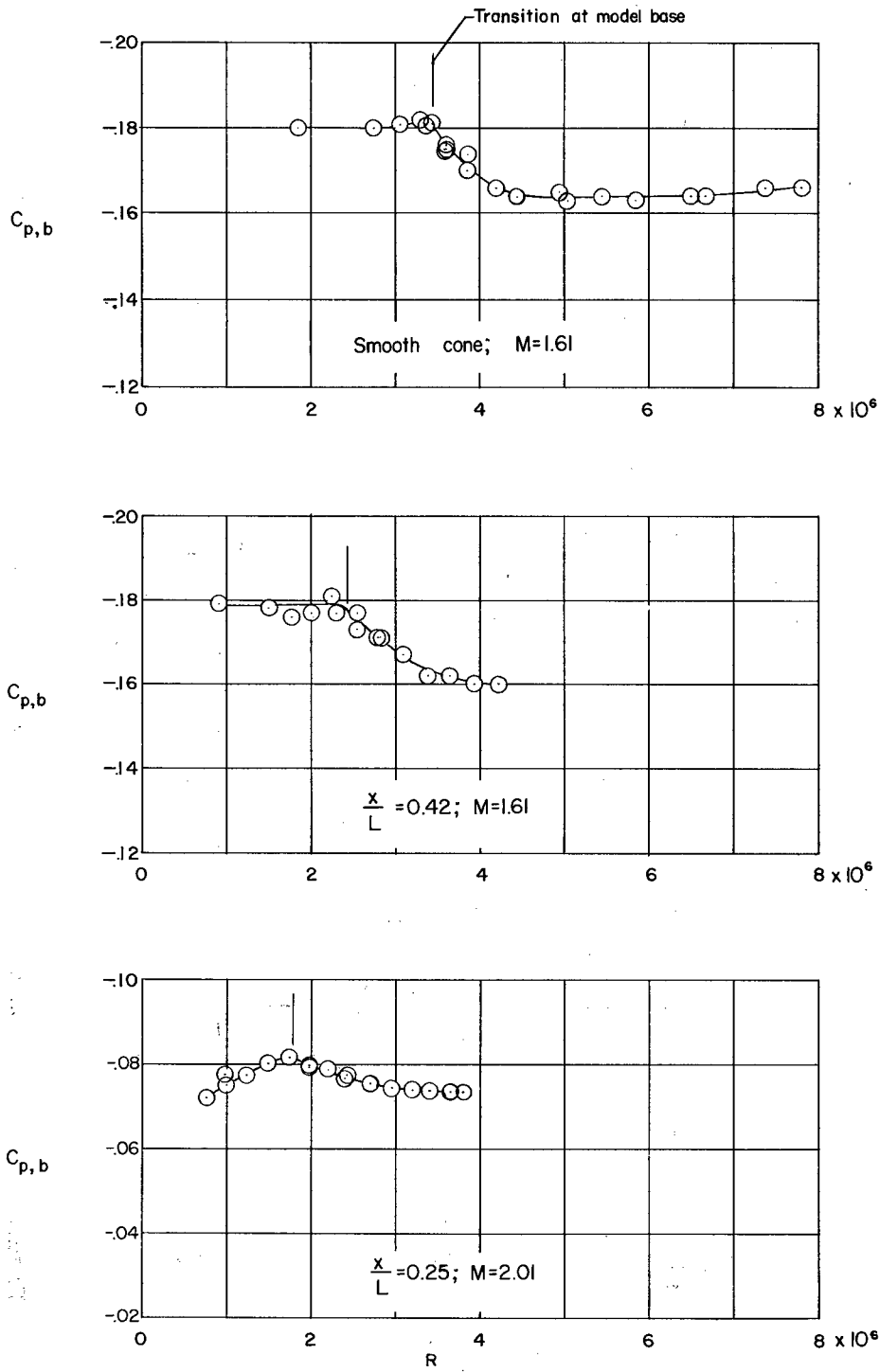

Figure 6.- Typical variations of base pressure coefficient with Reynolds number per foot showing how transition at model base was determined.

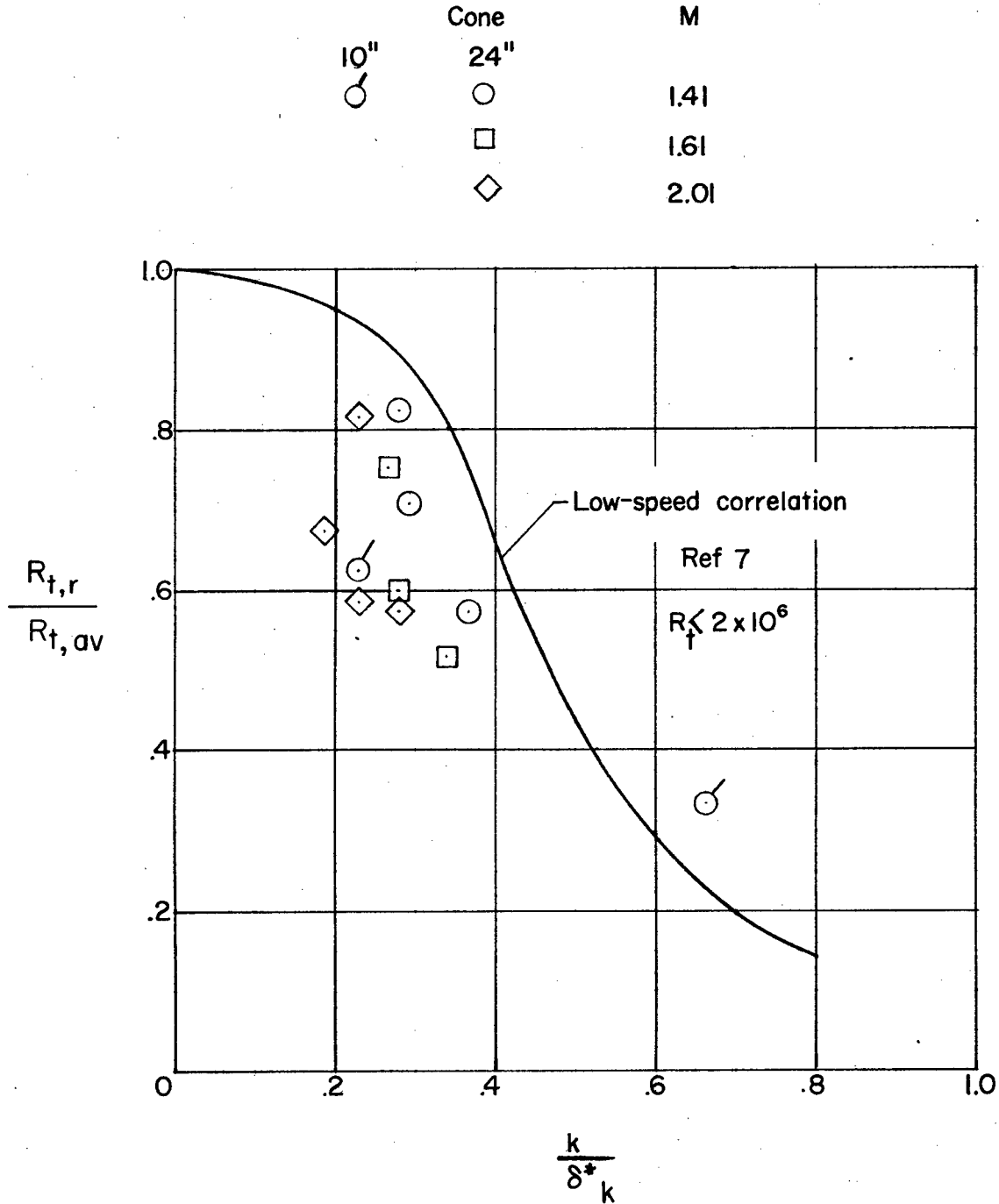

Figure 7.- Variation of transition Reynolds number ratio $R_{t,r}/R_{t,av}$ with ratio of roughness height to boundary-layer displacement thickness at the roughness k/δ^*_k .

NACA TN 3648
National Advisory Committee for Aeronautics.
INVESTIGATION OF BOUNDARY-LAYER TRANSITION ON 10° CONE IN LANGLEY 4- BY 4-FOOT SUPERSONIC PRESSURE TUNNEL AT MACH NUMBERS OF 1.41, 1.61, AND 2.01. Archibald R. Sinclair and K. R. Czarnecki. May 1956. 17p. diags., photos. (NACA TN 3648)

An investigation has been made to determine the transition Reynolds numbers on a 10° cone in the Langley 4- by 4-foot supersonic pressure tunnel at Mach numbers of 1.41, 1.61, and 2.01 and over a Reynolds number range from about 0.8 x 10⁶ to 9.5 x 10⁶ per foot. The results indicated that the transition Reynolds numbers increased with tunnel stagnation pressure and that there was no effect of Mach number on transition Reynolds numbers. A single-element surface roughness caused a larger decrease in transition Reynolds number than was experienced in low-speed or in other supersonic wind-tunnel investigations.
Copies obtainable from NACA, Washington

1. Flow, Laminar (1.1.3.1)
2. Wind Tunnels (9.1.1)
- I. Sinclair, Archibald R.
- II. Czarnecki, Kazimierz Roman
- III. NACA TN 3648



NACA TN 3648
National Advisory Committee for Aeronautics.
INVESTIGATION OF BOUNDARY-LAYER TRANSITION ON 10° CONE IN LANGLEY 4- BY 4-FOOT SUPERSONIC PRESSURE TUNNEL AT MACH NUMBERS OF 1.41, 1.61, AND 2.01. Archibald R. Sinclair and K. R. Czarnecki. May 1956. 17p. diags., photos. (NACA TN 3648)

An investigation has been made to determine the transition Reynolds numbers on a 10° cone in the Langley 4- by 4-foot supersonic pressure tunnel at Mach numbers of 1.41, 1.61, and 2.01 and over a Reynolds number range from about 0.8 x 10⁶ to 9.5 x 10⁶ per foot. The results indicated that the transition Reynolds numbers increased with tunnel stagnation pressure and that there was no effect of Mach number on transition Reynolds numbers. A single-element surface roughness caused a larger decrease in transition Reynolds number than was experienced in low-speed or in other supersonic wind-tunnel investigations.
Copies obtainable from NACA, Washington

NACA TN 3648
National Advisory Committee for Aeronautics.
INVESTIGATION OF BOUNDARY-LAYER TRANSITION ON 10° CONE IN LANGLEY 4- BY 4-FOOT SUPERSONIC PRESSURE TUNNEL AT MACH NUMBERS OF 1.41, 1.61, AND 2.01. Archibald R. Sinclair and K. R. Czarnecki. May 1956. 17p. diags., photos. (NACA TN 3648)

An investigation has been made to determine the transition Reynolds numbers on a 10° cone in the Langley 4- by 4-foot supersonic pressure tunnel at Mach numbers of 1.41, 1.61, and 2.01 and over a Reynolds number range from about 0.8 x 10⁶ to 9.5 x 10⁶ per foot. The results indicated that the transition Reynolds numbers increased with tunnel stagnation pressure and that there was no effect of Mach number on transition Reynolds numbers. A single-element surface roughness caused a larger decrease in transition Reynolds number than was experienced in low-speed or in other supersonic wind-tunnel investigations.
Copies obtainable from NACA, Washington

1. Flow, Laminar (1.1.3.1)
2. Wind Tunnels (9.1.1)
- I. Sinclair, Archibald R.
- II. Czarnecki, Kazimierz Roman
- III. NACA TN 3648



NACA TN 3648
National Advisory Committee for Aeronautics.
INVESTIGATION OF BOUNDARY-LAYER TRANSITION ON 10° CONE IN LANGLEY 4- BY 4-FOOT SUPERSONIC PRESSURE TUNNEL AT MACH NUMBERS OF 1.41, 1.61, AND 2.01. Archibald R. Sinclair and K. R. Czarnecki. May 1956. 17p. diags., photos. (NACA TN 3648)

An investigation has been made to determine the transition Reynolds numbers on a 10° cone in the Langley 4- by 4-foot supersonic pressure tunnel at Mach numbers of 1.41, 1.61, and 2.01 and over a Reynolds number range from about 0.8 x 10⁶ to 9.5 x 10⁶ per foot. The results indicated that the transition Reynolds numbers increased with tunnel stagnation pressure and that there was no effect of Mach number on transition Reynolds numbers. A single-element surface roughness caused a larger decrease in transition Reynolds number than was experienced in low-speed or in other supersonic wind-tunnel investigations.
Copies obtainable from NACA, Washington

1. Flow, Laminar (1.1.3.1)
2. Wind Tunnels (9.1.1)
- I. Sinclair, Archibald R.
- II. Czarnecki, Kazimierz Roman
- III. NACA TN 3648



NACA TN 3648

National Advisory Committee for Aeronautics.
INVESTIGATION OF BOUNDARY-LAYER TRANSI-
TION ON 10° CONE IN LANGLEY 4- BY 4-FOOT
SUPERSONIC PRESSURE TUNNEL AT MACH NUM-
BERS OF 1.41, 1.61, AND 2.01. Archibald R.
Sinclair and K. R. Czarnecki. May 1956. 17p.
diags., photos. (NACA TN 3648)

An investigation has been made to determine the transition Reynolds numbers on a 10° cone in the Langley 4- by 4-foot supersonic pressure tunnel at Mach numbers of 1.41, 1.61, and 2.01 and over a Reynolds number range from about 0.8×10^6 to 9.5×10^6 per foot. The results indicated that the transition Reynolds numbers increased with tunnel stagnation pressure and that there was no effect of Mach number on transition Reynolds numbers. A single-element surface roughness caused a larger decrease in transition Reynolds number than was experienced in low-speed or in other supersonic wind-tunnel investigations.
Copies obtainable from NACA, Washington

1. Flow, Laminar

- (1.1.3.1)
2. Wind Tunnels (9.1.1)
I. Sinclair, Archibald R.
II. Czarnecki, Kazimierz Roman
III. NACA TN 3648



NACA TN 3648

National Advisory Committee for Aeronautics.
INVESTIGATION OF BOUNDARY-LAYER TRANSI-
TION ON 10° CONE IN LANGLEY 4- BY 4-FOOT
SUPERSONIC PRESSURE TUNNEL AT MACH NUM-
BERS OF 1.41, 1.61, AND 2.01. Archibald R.
Sinclair and K. R. Czarnecki. May 1956. 17p.
diags., photos. (NACA TN 3648)

An investigation has been made to determine the transition Reynolds numbers on a 10° cone in the Langley 4- by 4-foot supersonic pressure tunnel at Mach numbers of 1.41, 1.61, and 2.01 and over a Reynolds number range from about 0.8×10^6 to 9.5×10^6 per foot. The results indicated that the transition Reynolds numbers increased with tunnel stagnation pressure and that there was no effect of Mach number on transition Reynolds numbers. A single-element surface roughness caused a larger decrease in transition Reynolds number than was experienced in low-speed or in other supersonic wind-tunnel investigations.
Copies obtainable from NACA, Washington

1. Flow, Laminar

- (1.1.3.1)
2. Wind Tunnels (9.1.1)
I. Sinclair, Archibald R.
II. Czarnecki, Kazimierz Roman
III. NACA TN 3648

