

AFFDL-TM-75-46-FXN

Reproduced From  
Best Available Copy

AIR FORCE FLIGHT DYNAMICS LABORATORY  
DIRECTOR OF LABORATORIES  
AIR FORCE SYSTEMS COMMAND  
WRIGHT PATTERSON AIR FORCE BASE OHIO

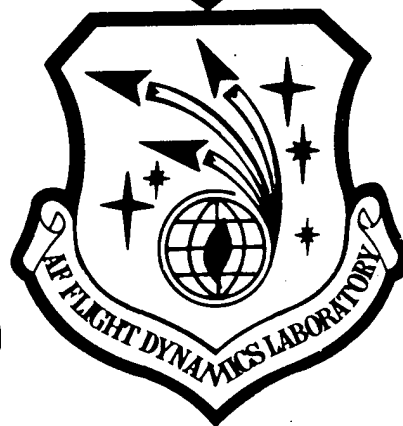

A LASER SHADOWGRAPH FOR  
FLOW VISUALIZATION IN THE  
AFFDL RENT FACILITY

June 1975

*Approved for public release; distribution unlimited.*

TECHNICAL MEMORANDUM AFFDL - TM - 75 - 46 - FXN

Research and Development Group  
Experimental Engineering Branch  
Flight Mechanics Division  
Air Force Flight Dynamics Laboratory  
Wright-Patterson Air Force Base, Ohio 45433

20000509 142

NOTICE

When Government drawings, specifications, or other data are used for any purpose other than in connection with a definitely related Government procurement operation, the United States Government thereby incurs no responsibility nor any obligation whatsoever; and the fact that the government may have formulated, furnished, or in any way supplied the said drawings, specifications, or other data, is not to be regarded by implication or otherwise as in any manner licensing the holder or any other person or corporation, or conveying any rights or permission to manufacture, use or sell any patented invention that may in any way be related thereto.

This report has been reviewed and cleared for open publication and/or public release by the appropriate Office of Information (OI) in accordance with AFR 190-7 and DODD 5203.9. There is no objection to unlimited distribution of this report to the public at large or by DDC to the National Technical Information Service (NTIS).

This Technical Memorandum has been reviewed and is approved for publication.

*Robert F. Carpenter*

ROBERT F. CARPENTER  
Physicist, R&D Group  
Experimental Engrg. Br.

FOR THE COMMANDER

*Donald J. Hamer*

for ALFRED C. DRAPER  
Act. Chief, Flight Mechanics Division  
AF Flight Dynamics Laboratory

AFFDL TM 75-46-FXN

A LASER SHADOWGRAPH FOR  
FLOW VISUALIZATION IN THE  
AFFDL RENT FACILITY

*Robert F. Carpenter*

*June 1975*

*Approved for public release; distribution unlimited.*

TECHNICAL MEMORANDUM AFFDL - TM - 75 - 46 - FXN

Research and Development Group  
Experimental Engineering Branch  
Flight Mechanics Division  
Air Force Flight Dynamics Laboratory  
Wright-Patterson Air Force Base, Ohio 45433

## FOREWORD

This technical memorandum describes a laser shadowgraph which was developed for flow visualization in the luminous arc heated flows produced by the Air Force Flight Dynamics Laboratory Reentry Nose Tip Facility (RENT).

Under Task Number 142601, "Diagnostic, Instrumentation and Similitude", managed by Mr. Daniel M. Parobek, this instrument was developed and tested under in house work unit 14260131 "Laser Shadowgraph for the RENT Facility for Testing Missile and Reentry Vehicle Nose Tips."

This shadowgraph was designed and the report written by the principal investigator Robert F. Carpenter. Much of the optical alignment and testing was performed by the associate investigator, Arthur G. Stringer. Design work for the laser mount was done by John B. Ankeney. Photographic support was provided by Charles Harris. Mrs. Willa Scott prepared the draft for publication and MSgt. Donald J. Rutkowski and Sgt. Roger D. Crosley prepared the figures.

## ABSTRACT

A laser shadowgraph is described which has been used for flow visualization in the Air Force Flight Dynamics Reentry Test Facility. The test flows are arc heated, supersonic, high pressure and high energy. The shadowgraph uses a He-Ne laser, spatial filter, collimating lens, camera lens, spectral filter and a camera body fitted with a neutral density filter to take shadowgraphs of shock waves around calibration probes in the RENT facility. The shadowgraph shows bow shock waves and shocks from the shoulder on the models as well as compression waves from the nozzle. Although it does not completely discriminate against flow luminosity the overexposed regions are limited enough to enable the observation of the shock waves in the luminous flows of this facility.

## TABLE OF CONTENTS

	Page
Introduction.....	1
Theory of the Shadowgraph.....	2
The Installation in the RENT Facility.....	10
Results.....	14
Conclusions.....	22
References.....	23

## ILLUSTRATIONS

<u>Figure</u>		<u>Page</u>
1	Simple Shadowgraph System.....	3
2	Effect of a Uniform Density Gradient on a Shadowgram....	5
3	Effect of Changing Density Gradient on a Shadowgram.....	6
4	Effect of an Extended Source on a Shadowgram.....	7
5	Practical Shadowgraph System with Relay Lens.....	9
6	Shadowgraph Installation in the RENT Facility.....	11
7	Shadowgraph of Test Run RTN 39-82 Model 1.....	15
8	Shadowgraph of Test Run RTN 39-82 Model 2.....	16
9	Shadowgraph of Test Run RTN 33-82 Model 3.....	17
10	Shadowgraph of Test Run RTN 33-84 Model 1.....	19
11	Shadowgraph of Test Run RTN 39-84 Model 2.....	20
12	Shadowgraph of Test Run RTN 39-84 Model 3.....	21

## INTRODUCTION

The RENT Facility is a high pressure arc heated supersonic wind tunnel which generates a high density, high shear flow. A Linde type 50 MW arc heater produces a flow of up to 8 lb/sec (3.64 kg/sec) of high pressure air at stagnation pressures up to 125 atmospheres. The air is expanded through a convergent-divergent nozzle to supersonic speeds. This facility is described in Reference 1.

This facility is used for testing nose tip materials for reentry missiles. The desirability of testing larger models with this facility led to the concept of the internal shrouded flow nozzle. In this nozzle, cold shroud air is injected in the nozzle to enlarge the size of the useful test flow. As part of the development of this concept, a means of flow visualization was needed to evaluate the flow. The shroud flow nozzle is described in Reference 2.

Since high enthalpy flows are luminous and can quickly raise test models to incandescence, conventional flow visualization schemes are not useful and a laser shadowgraph was designed to provide flow visualization in this facility.

A shadowgraph configuration was chosen over a schlieren system principally due to the fact that schlieren systems are much more sensitive to thermal gradients which are unavoidable in this type of facility. These extraneous thermal gradients in the light path would produce such background disturbances as to make interpretation of the photographs nearly impossible.

## THEORY OF THE SHADOWGRAPH

Optical flow visualization systems function because the index of refraction of air is slightly dependent upon density. The index of refraction is given by

$$n = 1 + k \rho / \rho_0$$

where:  $n$  = index of refraction

$\rho$  = density of air

$\rho_0$  = density of air at 0°C and 1 atm

$k$  = constant = 0.00028 for air.

This varying index of refraction bends light as it passes through the test section. With suitable optical apparatus, such as schlieren or shadowgraph systems, the effects of the changes in air density can be recorded on film. A shadowgraph system was more suitable in this case and its principle of operation is described below.

The manner in which a shadowgraph operates is easy to visualize if the density variations are considered to occur only in a small portion of the optical path which may be considered as a thin slab. This approximation is realistic since appreciable density variations occur only in the shock region around a model or in convection currents from hot objects in the optical path, and are thus localized.

A shadowgraph system is schematically shown in Figure 1. It consists of a small illuminated aperture which serves as a light source, expanding and collimating lenses, a test section, and film or a viewing screen. Density changes in the test section bend light in a way which

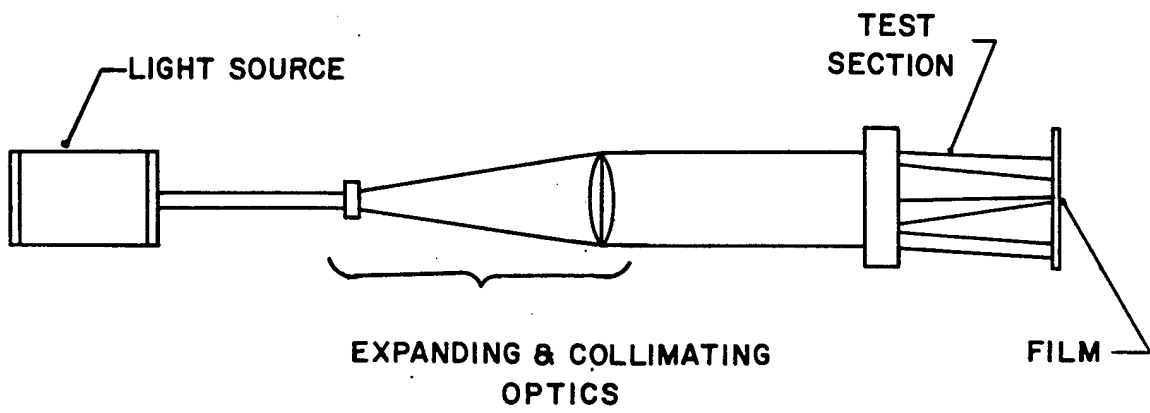

SIMPLE SHADOWGRAPH SYSTEM

FIG. 1

will be analyzed by giving some examples. The effect of a uniform density gradient is analyzed in Figure 2. As can be seen, the effect of such a gradient is to displace the image but leaves the film density unchanged.

The effect of nonuniform density gradients upon the image is shown in Figure 3. The effects of nonuniform gradients are simulated by lenses. As can be seen, a region with higher index of refraction in the center is analogous to a convex lens and a region with a low index of refraction in the center is analogous to a concave lens. This lens effect gives lighter and darker areas on the film. Note that a greater test section to film distance leads to greater changes in film density, and therefore, to greater sensitivity.

As shown in Figure 4, an extended source provides a nonparallel source beam. This nonparallel beam produces a blurred image of an object in the test section. The larger the source and the greater the object to film distance, the more blurred is the image of the object. Note that the effect of varying the object to film distance is important both in the sensitivity and clarity of the image.

There are three mechanisms which degrade the definition of images on the film. As noted above, an extended source will lead to a nonparallel source beam and blurring of the image. If a conventional light source is used, a compromise must be made. A large source area gives a bright image, but poor resolution, and a small source area the converse. The brightness of the source (watts/cm<sup>2</sup>-sterdian) determines the severity of the compromise. The extreme brightness of the laser almost eliminates this source of blurring.

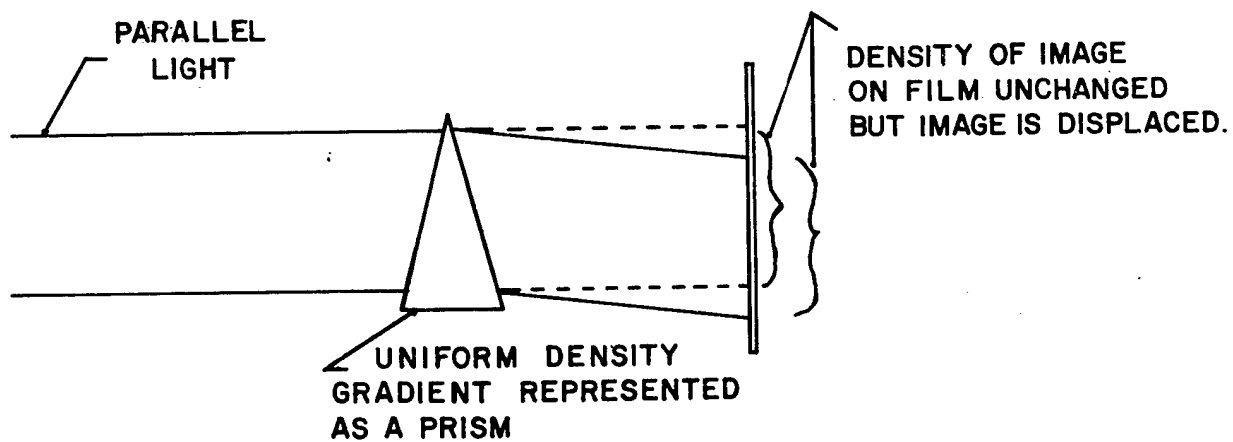

EFFECT OF A UNIFORM DENSITY GRADIENT  
ON A SHADOWGRAM

FIG. 2

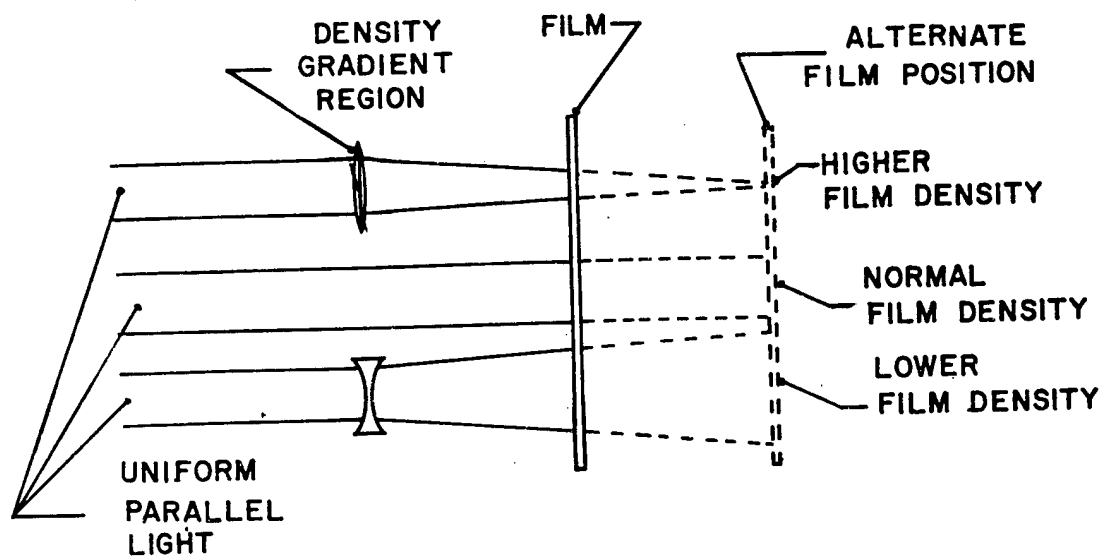

EFFECT OF CHANGING DENSITY GRADIENT ON A SHADOWGRAM

FIG. 3

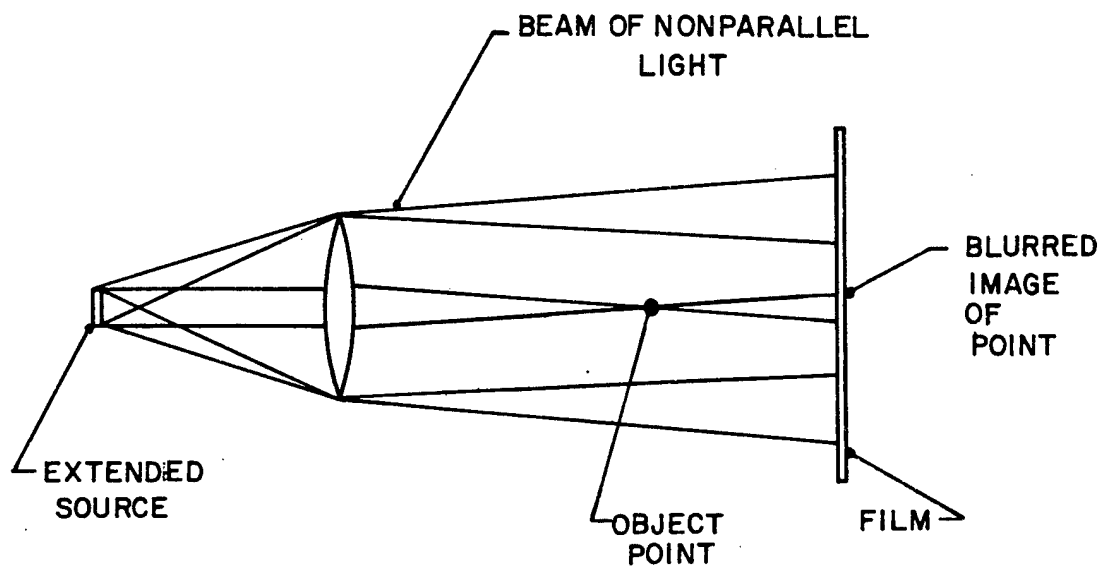

EFFECT OF AN EXTENDED SOURCE ON A SHADOWGRAM

FIG. 4

Image definition is also degraded by the diffraction effect of the monochromatic laser light as is evident by the fringes at the edges of the field of view. Dirt and scratches on lenses also cause diffraction patterns which are annoying but do not usually interfere with the interpretation of data. These diffraction effects are much more severe in schlieren systems than in shadowgraph systems.

The third and most important cause of image blurring is the displacement of image points due to density gradients in the test area, the effect of which is to produce nonparallel light. Figures 2 and 4 show how nonparallel light in the test section will cause lack of definition. The displacement is proportional to the distance from the film, as is the sensitivity of the system, so this effectively provides a limit on the sensitivity. It is impossible to increase system sensitivity without decreasing image quality.

In practice, the location of film near the test section is impractical and a lens is used to relay the image plane onto the film. This lens can be used to move the location of the image plane and to provide magnification. A standard camera body is very convenient for holding the film since it has a shutter and film transport mechanism. A diagram of a practical shadowgraph system is shown in Figure 5. Note that the camera lens system must have an input aperture the size of the region to be viewed since it accepts approximately parallel light.

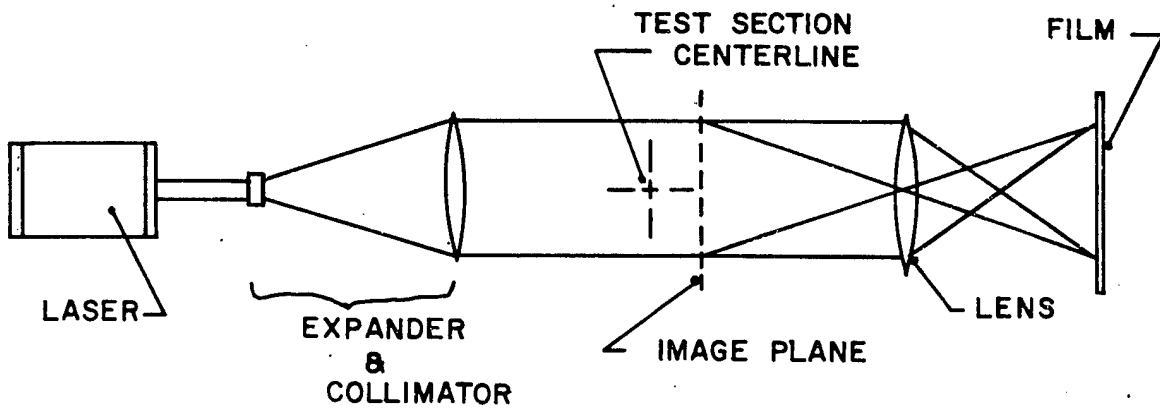

PRACTICAL SHADOWGRAPH SYSTEM WITH RELAY LENS.

FIG. 5

## THE INSTALLATION IN THE RENT FACILITY

The highly luminous flow and model in the RENT facility preclude the use of normal light sources for flow visualization since they are not bright enough. A laser source, however, is extremely bright and monochromatic, both of which properties are necessary for successful flow visualization in this facility, the brightness to allow sufficient light to operate in the presence of the flow luminosity, and also to allow a small virtual source. The monochromatic property is necessary to enable the use of filters to discriminate against the continuum radiation of the flow and arc radiation reflected from the model.

The optical layout of the shadowgraph used in the RENT facility is shown in Figure 6. The light source consists of a 15 mW He-Ne laser, Spectra Physics model 124A. The radiation is passed through a lens pinhole spatial filter, Jodon Associates model LPSF 100 with a 40 power microscope objective lens and a 10 micron pinhole. The microscope objective takes the approximately one millimeter diameter output beam from the laser and focuses it onto the 10 micron aperture in the spatial filter. This aperture is of such size and located so that the only light passing through it is that emitted from the  $TEM_{00}$  mode of the laser. This mode has the least divergence of any of the laser modes and gives the most uniform illumination of the test region. The light passing through the pinhole is collimated with a 0.5 meter focal length lens 12.5 cm. in diameter, to produce a parallel beam of monochromatic light the diameter of the collimating lens.

The parallel light was then folded by a front surface mirror and passed through the RENT flow to the camera setup. The camera arrange-

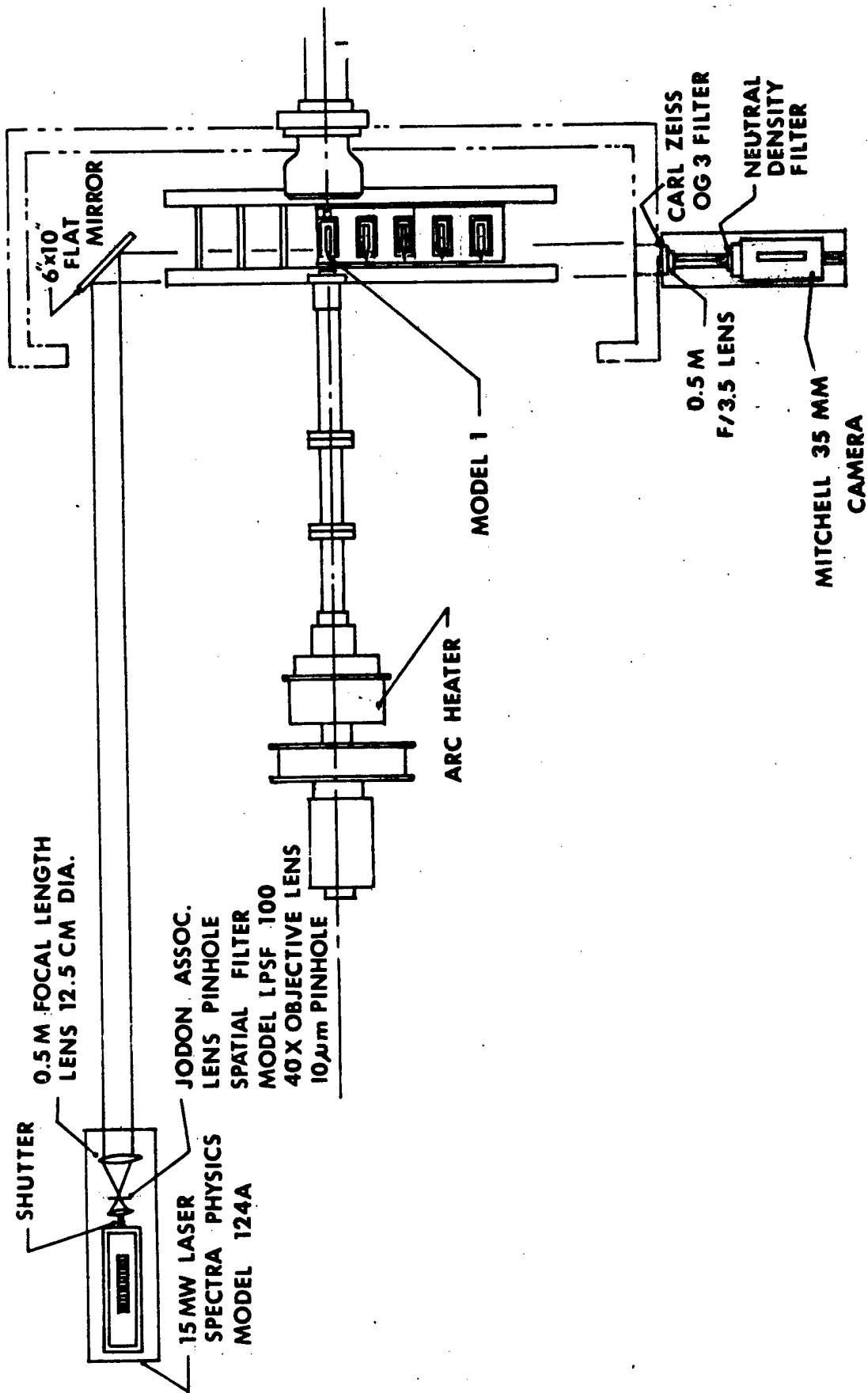

SHADOWGRAPH INSTALLATION IN THE  
RENT FACILITY  
FIG. 6

ment consists of a f/3.5 aerial camera lens of 0.5 meter focal length fitted with a deep red filter. This lens images the test section onto the film plane of a Mitchell 35 mm. high speed motion picture camera.

This camera, with two interchangeable motors, has framing rates from 8 frames/sec to 128 frames/sec. The camera shutter has an adjustable angle aperture which is adjustable in 5° increments from 5° to 165°, thus providing an exposure time given by the expression:

$$t = \frac{\theta}{360} \times \frac{1}{S}$$

where:  $t$  = exposure time, sec.

$\theta$  = shutter angle, deg.

$S$  = frames/sec.

The combination of the red filter and the sensitivity curve for panchromatic film (Eastman Super XX) allows the system to respond almost entirely to light in a wavelength range around the He-Ne laser line which is located at 6328Å. The filter effectively blocks wavelengths less than 6000Å while the film sensitivity curve indicates no sensitivity at wave length greater than 6600Å. The camera also has a neutral density filter which further reduces illumination from the flow and any model in the flow. These filters, while they do not completely discriminate against the continuum radiation from the flow and reflections from the model, keep the overexposed region of the film sufficiently limited in area so that the shock waves from the model tip and shoulders, and the nozzle shock waves are clearly visible.

The physical arrangement of models along the model support carriage and the other constraints imposed by the facility are such that the only optical path available was along the horizontal centerline of the facility. Thus in all the shadowgraphs taken with this installation, the silhouettes of all the models on the carriage appear superimposed. The superposition of models makes the interpretation of shadowgraphs more difficult since a portion of the field of view is obscured by the other models if all the models are not identical in shape.

Another severe difficulty experienced with this system is that hot models which have been in the flow produce convection currents in the optical path. These currents produce a noisy background on any shadowgraphs taken late in the run after some of the models have left the flow, if the first models were sufficiently heated to produce the currents. It should be noted that the color filtering is not sufficiently narrow band to enable shadowgraphs to be made of brightly incandescent models.

panchromatic film (Eastman Super XX) allows the system to respond almost entirely to light in a wavelength range around the He-Ne laser line which is located at 6328 Å. The filter effectively blocks wavelengths less than 5000 Å while the film sensitivity curve indicates no sensitivity of wave length greater than 6500 Å. The camera also has a neutral density filter which further reduces illumination from the flow and any model in the flow. These filters, while they do not completely discriminate against the continuum radiation from the flow and reflections from the model, keep the overexposed region of the film sufficiently limited in area so that the shock waves from the model tip and shoulders, and the nozzle shock waves are clearly visible.

## RESULTS

As examples of the shadowgraphs taken with the laser shadowgraph the following photographs are shown. They were taken with unshrouded flows and the 1.1 inch nozzle. The camera was set for 100 frames/sec., a 50° shutter angle and was equipped with a ND3 filter as well as the red filter on the camera lens. The camera lens was focused 4 inches toward the camera from the model. The camera speed and shutter angle give an exposure time of 1/720 sec. The models were uncooled metal models swept through the flow at 25 inches/sec.

Figures 7, 8 and 9 were taken on test RTN 33-082 and are shadowgraphs of the models on struts 1, 2 and 3 respectively. For this run the reservoir pressure was 900 psia and the arc heater current was 2600 amperes which with the nozzle configuration used provides a predicted stagnation pressure behind a normal shock wave,  $p_{t2}$ , of 50 atmospheres at the models.

The in-line arrangement of the models along the light path conceals a portion of the models being tested from view in all the shadowgraphs in this report. Figure 7 shows the bow shock just in front of the luminous gas cap and a shock wave from a shoulder on a model on strut 1.

Figure 8, which is a shadowgraph of the model on strut 2, shows the bow shock from the nose on the model. The center of the light path is blocked by model 1, but the shock wave is evident in the rest of the photograph. Additionally, in this figure and others, the compression waves generated near the nozzle exit are discernable.

Figure 9 shows the shadowgraph of the model on strut 3 showing the shock wave. The shadowgraph shows decreased sharpness due to density

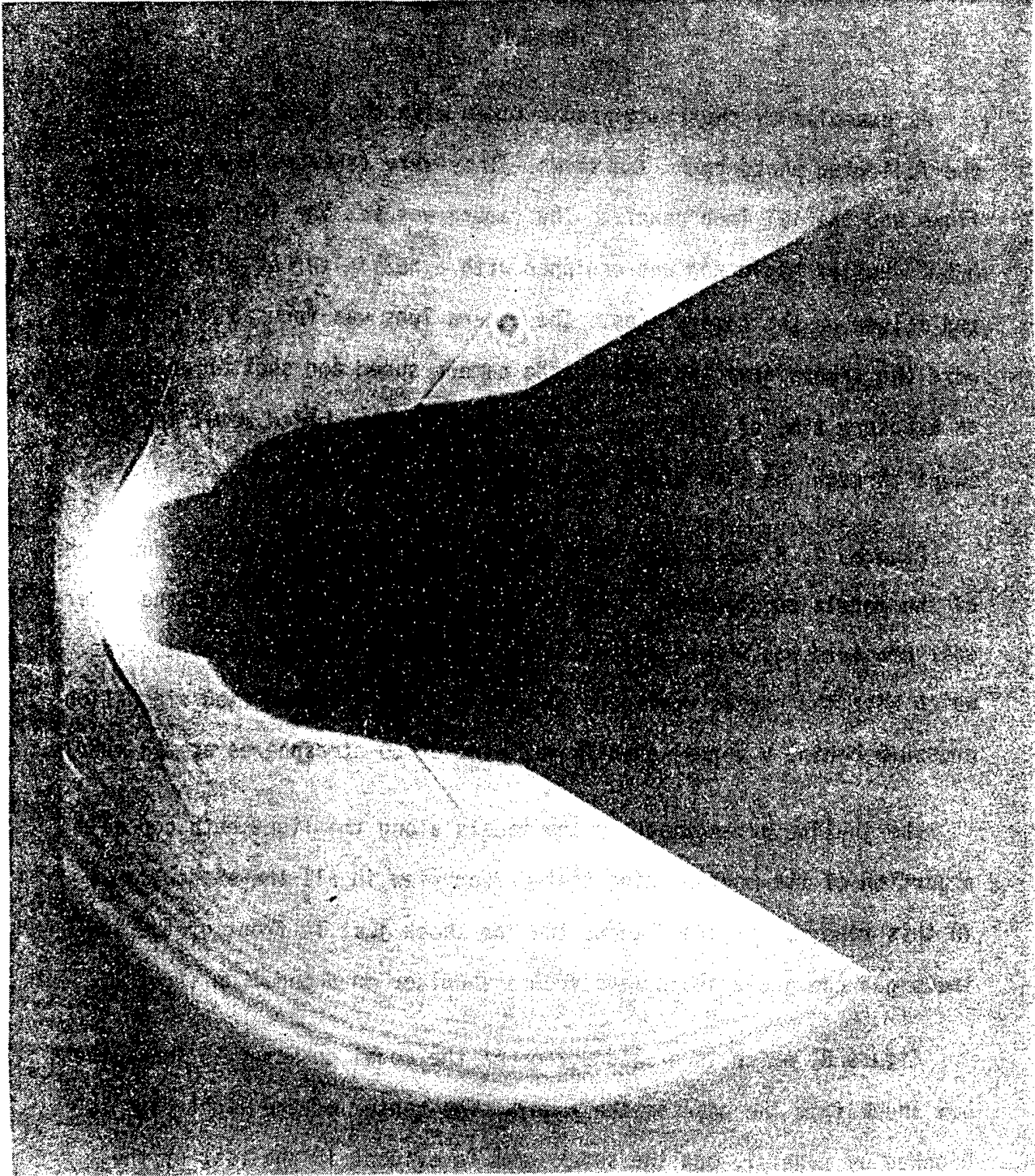

FIG. 7 SHADOWGRAPH OF TEST RUN RTN 33-82 MODEL 1

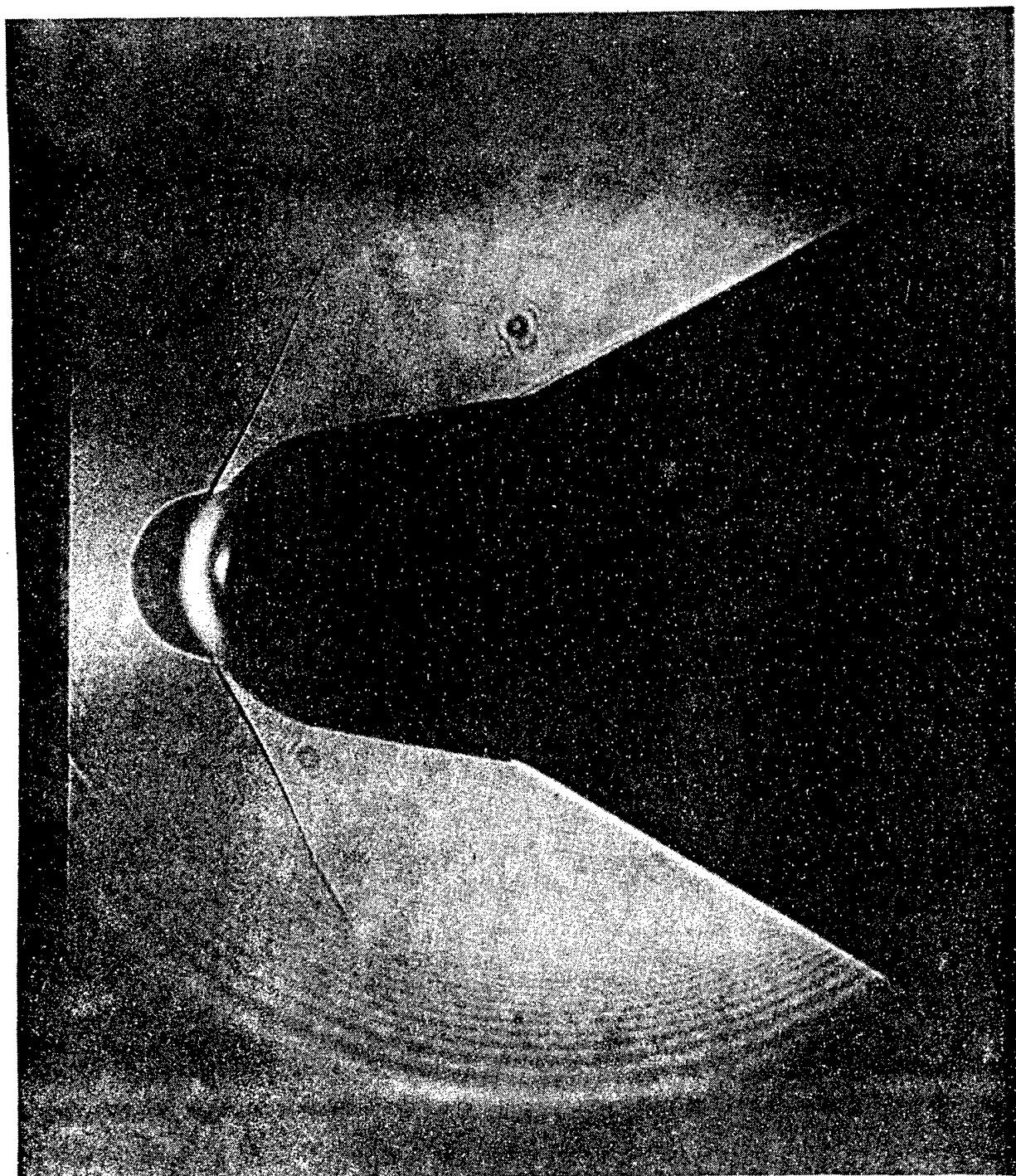

FIG. 8 SHADOWGRAPH OF TEST RUN RTN 33-82 MODEL 2

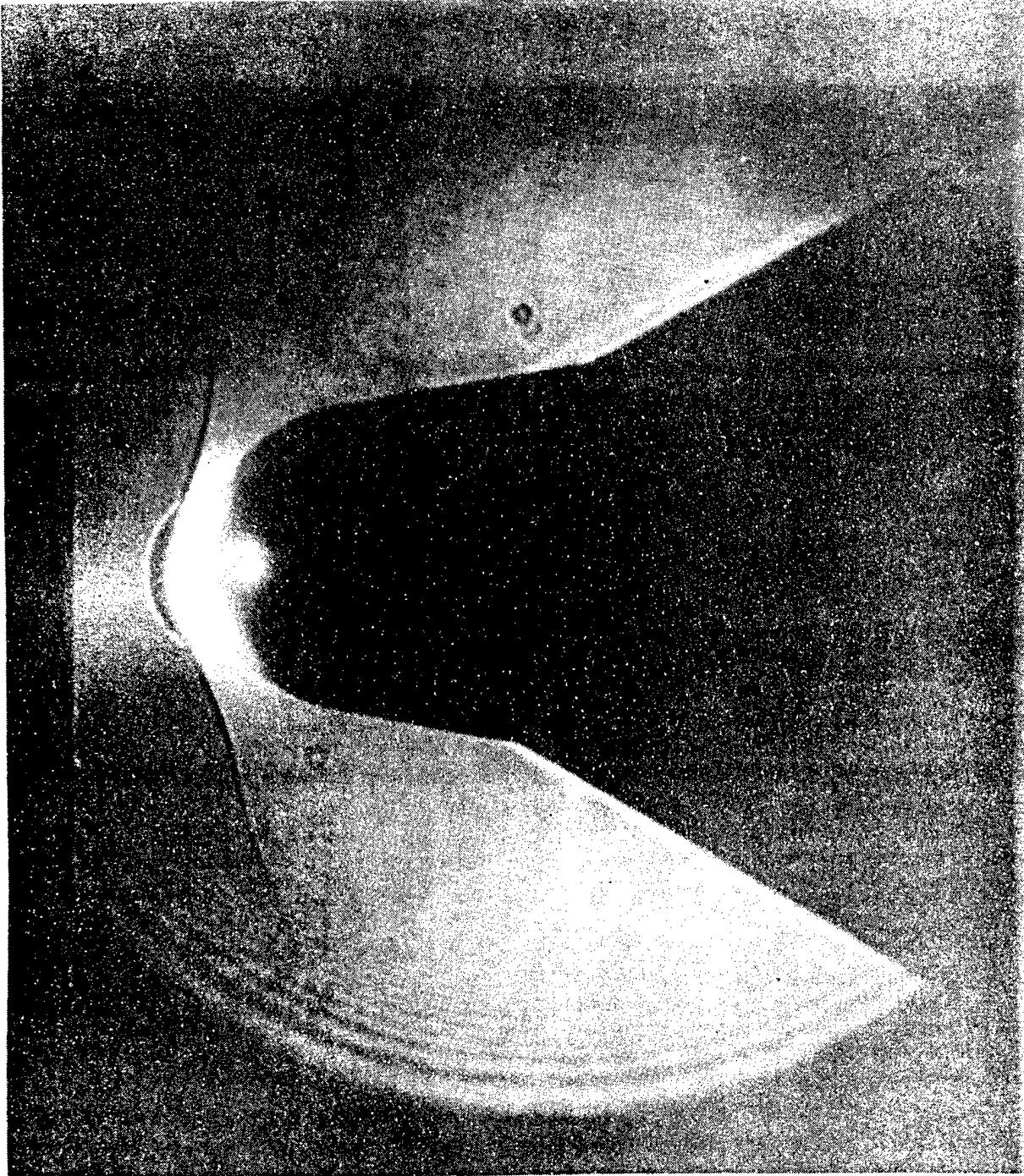

FIG. 9 SHADOWGRAPH OF TEST RUN RTN 33-82 MODEL 3

gradients in the test area.

Figures 10, 11 and 12 show similar results for test RTN 33-084, with the arc heater operated at a reservoir pressure of 1800 psia and a heater current of 2600 amperes, giving a predicted stagnation pressure behind a normal shockwave,  $p_{t2}$ , of 100 atmospheres at the models. Figure 10 shows the model on strut 1 with the luminosity of the bright gas cap not completely blocked by the filters. This shows the bow shock and the shock from the concealed shoulder of the model. Figure 11 shows the bow shock from the model on strut 2 with the sharpness of the background slightly degraded by density gradients in the air in the light path, while figure 12 shows the model on strut 3 with its shock wave. The sharpness of this shadowgraph is severely degraded by the density gradients in the light path. These density gradients result from the heating of the air in the light path by the hot models on struts 1 and 2 which have previously been in the flow.

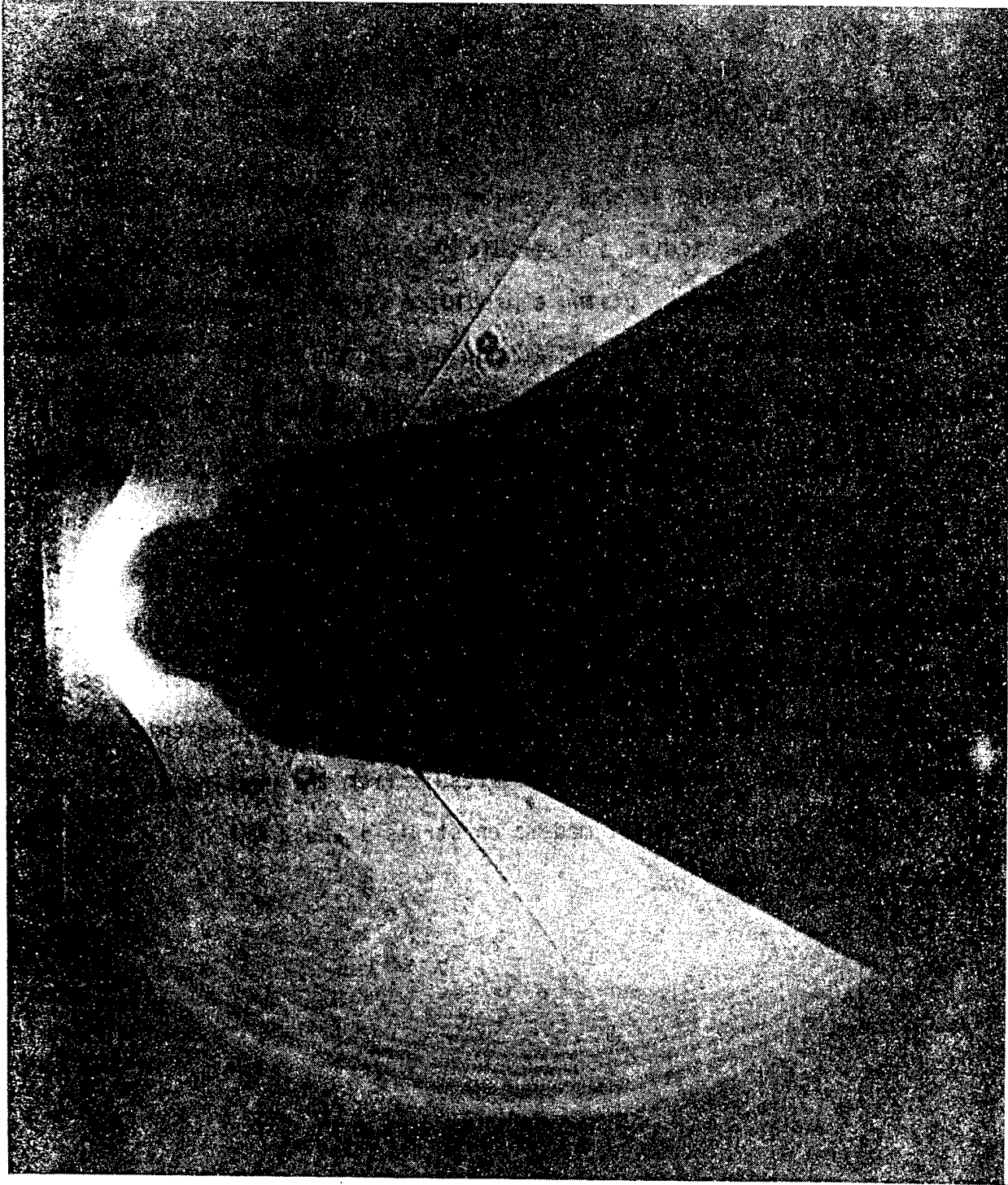

FIG. 10 SHADOWGRAPH OF TEST RUN RTN 33-84 MODEL 1

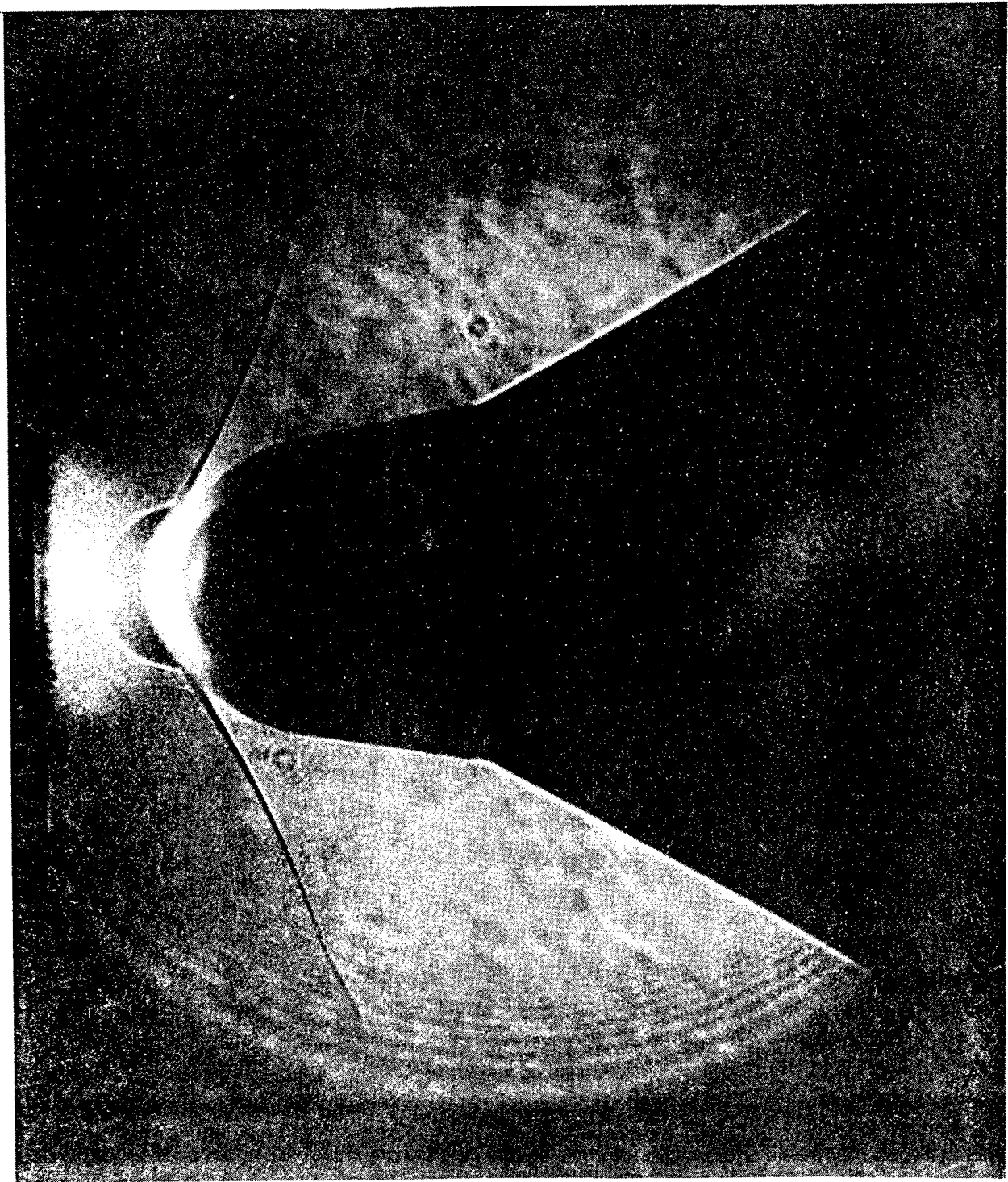

FIG. 11 SHADOWGRAPH OF TEST RUN RTN 33-84 MODEL 2

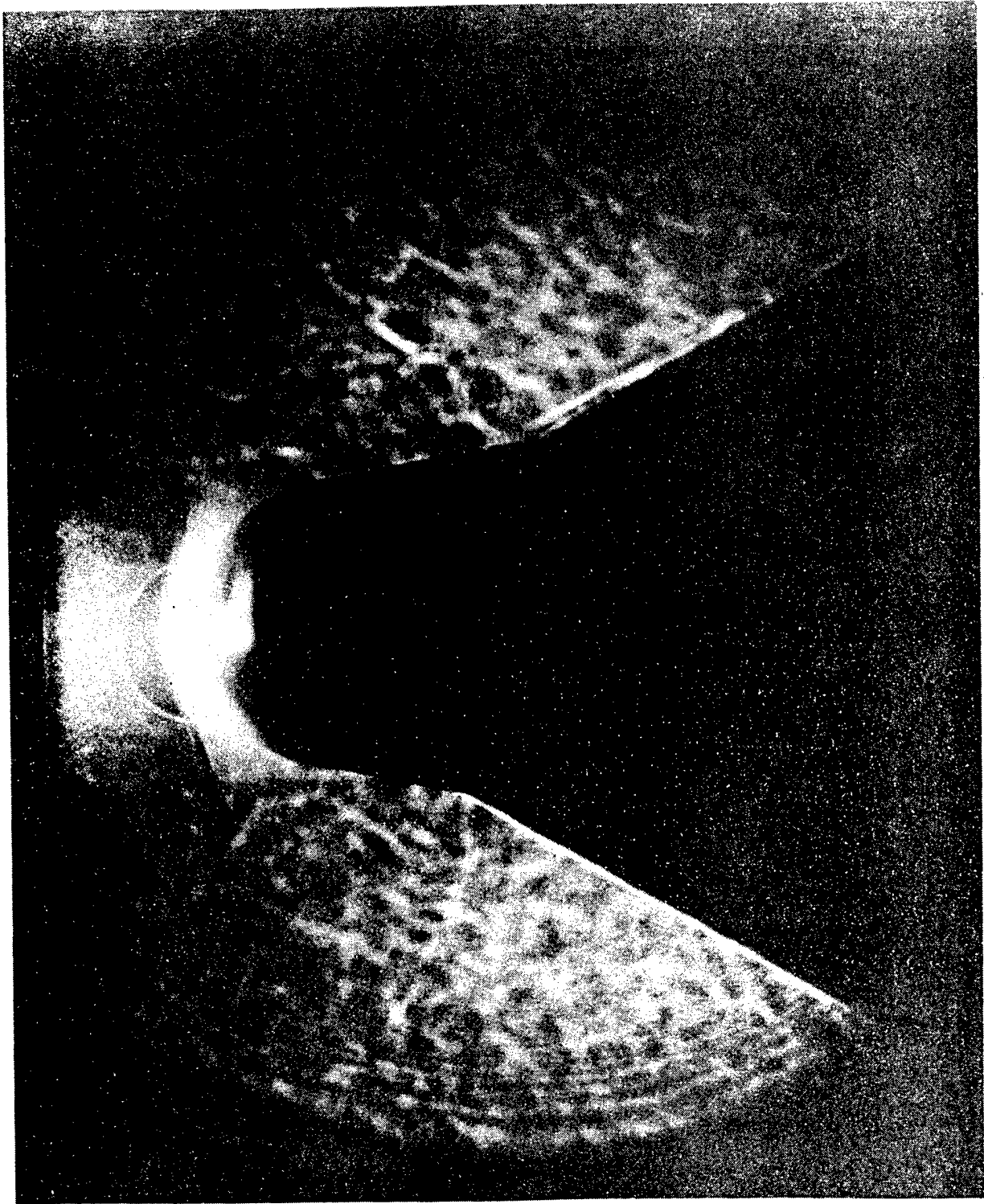

FIG. 12 SHADOWGRAPH OF TEST RUN RTN 33-84 MODEL 3

## CONCLUSION

A laser shadowgraph has been constructed for the AFFDL RENT facility, using a 15 milliwatt He-Ne laser, spatial filter, a collimating lens and camera lens. The camera lens was fitted with a deep red filter which together with the film sensitivity curve limits the sensitivity to the wave length region around the  $6328\text{\AA}$  wave length of the laser. The camera used was a 35 mm high speed motion picture camera, with frame rates from 8 frames/sec to 128 frames/sec. and variable shutter angles. This together with a neutral density filter provides discrimination against flow radiation and permits shadowgraphs to be taken through the luminous flow not only showing the strong model shocks present in the flow field, but also the compression waves near the nozzle exit.

## REFERENCES

1. TM 75-39 FXE, The 50 MEGAWATT FACILITY of the Air Force Flight Dynamics Laboratory, Information for Users. Third Edition, June 1975.
2. NASA SP336, 7th Conference on Space Simulation, Paper No. 34, Page 449. Nov 1973.