



**STRATEGY  
RESEARCH  
PROJECT**

The views expressed in this paper are those of the author and do not necessarily reflect the views of the Department of Defense or any of its agencies. This document may not be released for open publication until it has been cleared by the appropriate military service or government agency.

**TOWARDS A MORE RELEVANT ENGINEER COMMAND  
(ENCOM)**

**BY**

**COLONEL DAVID A. KINGSTON  
United States Army**

**DISTRIBUTION STATEMENT A:  
Approved for Public Release.  
Distribution is Unlimited.**

**USAWC CLASS OF 2000**



**U.S. ARMY WAR COLLEGE, CARLISLE BARRACKS, PA 17013-5050**

**20000522 075**

USAWC STRATEGY RESEARCH PROJECT

**Towards a More Relevant Engineer Command (ENCOM)**

by

Colonel David A. Kingston  
United States Army

Colonel John F. Troxell  
Project Advisor

The views expressed in this academic research paper are those of the author and do not necessarily reflect the official policy or position of the U.S. Government, the Department of Defense, or any of its agencies.

U.S. Army War College  
CARLISLE BARRACKS, PENNSYLVANIA 17013

DISTRIBUTION STATEMENT A:  
Approved for public release.  
Distribution is unlimited.



## ABSTRACT

AUTHOR: Colonel David A. Kingston  
TITLE: Towards A More Relevant Engineer Command (ENCOM)  
FORMAT: Strategy Research Project  
DATE: 07 April 2000                      PAGES: 27                      CLASSIFICATION: Unclassified

The current National Military Strategy of the United States identifies the requirements of shaping the international environment in ways favorable to U. S. interests, responding to the full spectrum of threats and crises that may arise, and preparing now for an uncertain future. Engineer support to military operations that fulfill these requirements has proven to be and will continue to be critical to success. It follows that for an engineer headquarters to be relevant in the new millennium, it must contribute to the shaping and responding requirements, and to joint and combined operations. The current doctrinal headquarters to execute theater army level command of engineer forces is the Engineer Command (ENCOM). This study shows that although the ENCOM is doctrinally organized to be a relevant headquarters, its performance during recent operations in the Persian Gulf and Bosnia indicates otherwise. The major weakness of the ENCOM is the lack of an active duty general officer and staff, thus making it less responsive to the Army Service Component Commander (ASCC) than it needs to be. This report advocates three changes to the ENCOM that will correct identified deficiencies. The first is placing a general officer and staff on active duty. The second is linking these active duty generals to a specific ASCC. The third is ensuring the active duty portion of the ENCOM is proficient at commanding joint engineer forces. These proposed changes will make the ENCOM relevant to the Post Cold War world.



## TABLE OF CONTENTS

ABSTRACT .....	III
PREFACE.....	VII
LIST OF ILLUSTRATIONS.....	IX
LIST OF TABLES.....	XI
TOWARDS A MORE RELEVANT ENGINEER COMMAND (ENCOM).....	1
DOCTRINAL BASIS FOR ENGINEER COMMANDS .....	2
THE ROLE OF THE ENCOM IN RECENT CONTINGENCY OPERATIONS.....	3
OPERATION DESERT SHIELD/DESERT STORM.....	4
OPERATION JOINT ENDEAVOR .....	6
THE FIX—MAKING ENCOMS MORE RELEVANT .....	8
DESERT SHIELD/STORM REVISITED.....	9
OPERATION JOINT ENDEAVOR REVISITED .....	9
CONCLUSION—THE WAY AHEAD .....	11
ENDNOTES .....	13
BIBLIOGRAPHY .....	15



## PREFACE

My interest in the subject of Engineer Commands developed from two events. First, as the Director of Combat Developments at the U. S. Army Engineer School, I was responsible for designing the engineer force structure, of which over seventy five percent is in the Reserve Components. The ENCOM is the highest engineer headquarters at the operational level in the force structure, and both the 412<sup>th</sup> and 416<sup>th</sup> ENCOMs are in the U. S. Army Reserves. Thus, I became interested in their doctrinal responsibilities and real world performance. Second, while deployed to Bosnia-Herzegovina from November 1997 to May 1998, I became convinced that an ENCOM should have contributed to the massive engineering effort in support of Operation Joint Endeavor and Operation Joint Guard. I wanted to know why the ENCOM was not able to more fully participate, and what changes, if any, were required to make this headquarters more relevant. My research has shown that ENCOMs are rich in talented, dedicated personnel and that they bring a capability to control theater level engineer forces that is unmatched by any other headquarters. The changes that I propose are designed to provide easier access to these organizations.

Among the professionals that have helped me in this project, two deserve special recognition. The first is COL John F. Troxell, who served as my Faculty Advisor. Jef has a wealth of experience in Echelon Above Corps operations, and provided superb advice and critical review. The second is BG Bob Heine, USAR, who is the current Deputy Commanding General of the Maneuver Support Center at FT Leonard Wood, MO. BG Heine spent many years serving in ENCOMs, culminating as the Chief of Staff of the 416<sup>th</sup> ENCOM. His insights and personal anecdotes concerning ENCOMs proved to be invaluable.

I would also like to acknowledge the support of my wife Dottie, and our three children. Without them, the completion of this project would not be possible.



## LIST OF ILLUSTRATIONS

FIGURE 1 - NOTIONAL ASCC THEATER ENGINEER LAYDOWN .....	2
FIGURE 2 - OPERATION JOINT ENDEAVOR ENGINEER STRUCTURE .....	7
FIGURE 3 - PROPOSED OPERATION JOINT ENDEAVOR ENGINEER STRUCTURE.....	10



**LIST OF TABLES**

TABLE 1 - DESERT SHIELD/DESERT STORM ENGINEER STRUCTURE.....5



## TOWARDS A MORE RELEVANT ENGINEER COMMAND (ENCOM)

The current National Security Strategy of the United States identifies three overarching requirements as we face a future of uncertainty in the new millennium. The first is the requirement to shape the international environment in ways favorable to U. S. interests and global security. The second is the requirement to respond at home and abroad to the full spectrum of threats and crises that may arise. The third is the requirement to prepare now for an uncertain future.<sup>1</sup> In all three of these, engineer support to potential military actions is absolutely critical to the success of the overall security strategy. Joint military combat and construction engineers and civilian contractors provide critical contributions to operations ranging from disaster relief to major contingencies.

From the above, it follows that for an engineer headquarters, particularly one at theater army level, to be relevant in this new era, it must contribute to the shaping and responding requirements of the National Military Strategy. Furthermore, it must contribute to joint and combined operations across the entire spectrum of combat. The current doctrinal headquarters to execute theater army level command of engineer forces is the Engineer Command (ENCOM).

Field Manual 5-100, Engineer Operations, describes the Engineer Command (ENCOM) as a major subordinate command of the Army Service Component Commander (ASCC). It provides command and control for the operational-level engineer support in theater.<sup>2</sup> The ENCOM plans and coordinates all operational-level engineering assets, including the command direction of topographic operations, construction, real property maintenance activities (RPMA), lines of communication sustainment, engineer logistics management, and base development. The ENCOM's coordinating responsibilities cover both military and civilian engineer capabilities, as well as joint and multinational engineers as directed.

Based on this description of the ENCOM's mission and responsibilities, one might reasonably conclude that the ENCOM should have been a lead player in planning and executing engineer missions for Operation Desert Shield/Storm, and for the ongoing peacekeeping operations in Bosnia and Kosovo. Yet, this was not the case.

In the Persian Gulf War, the 416<sup>th</sup> Engineer Command was not activated until 29 November 1990, and did not arrive in theater until 11 December 1990.<sup>3</sup> Thus, the 416<sup>th</sup> ENCOM almost completely missed Operation Desert Shield, and missed much of the preliminary planning for Operation Desert Storm. In the Balkan peacekeeping operations an Engineer Command was not activated at all. Instead, ad hoc engineer command relationships and non-doctrinal engineer staff organizations were created, resulting in a disjointed engineer effort.

The ENCOM did not take a more active role at the beginning of these particular crises and was unprepared to support the National Security Strategy, because they are composed almost entirely of reserve component personnel not on active duty. Thus, they often are not mobilized in time to take part in the preliminary planning, and do not develop the personal relationships with the ASCC command structure necessary for effective integration.

In developing this argument, three major objectives will be accomplished. The first objective is establishing the doctrinal basis for the establishment of Engineer Commands. Second, the theater engineer command and control organizations used in the Persian Gulf war and in the Balkan peacekeeping operations will be analyzed to substantiate the position that an ENCOM that is entirely in the Reserve Component lacks the responsiveness and cannot earn the trust needed by the Army Component Commander. Finally, is the proposition that an active duty engineer General Officer be dual hatted as the Deputy Commanding General of the ENCOM and as the engineer staff officer for the Army Component Commander for each geographical CINC. The Persian Gulf War and the Balkan peacekeeping operations will be revisited to show how this new structure would have greatly streamlined and improved engineer command and control for these massive undertakings.

### DOCTRINAL BASIS FOR ENGINEER COMMANDS

The doctrinal basis for U. S. Army Engineer Commands is located in several sources. FM 100-16, Army Operational Support, dated 31 May 1995, promulgated by the U. S. Army Training and Doctrine Command (TRADOC), includes a brief description of the responsibilities of the ENCOM. However, two manuals promulgated by the U. S. Army Engineer School are the primary sources that discuss in detail the missions, responsibilities, and organization of the Engineer Command. These are FM 5-100, Engineer Operations, dated 27 February 1996, and FM 5 -116, Engineer Operations: Echelons Above Corps, dated 9 February 1999.

As mentioned earlier, these manuals describe the ENCOM as a major subordinate command of the ASCC that commands and controls the operational-level engineers.<sup>4</sup> Figure 1 shows a notional ASCC theater engineer laydown.<sup>5</sup> The command and control structure allows the ENCOM to accomplish its major missions of topographic support, troop construction and repair to all U. S. elements in the Communication Zone, contract construction support, and support to tactical-level organizations, when required. Although not shown, the ENCOM can also control civilian and joint engineers in theater.

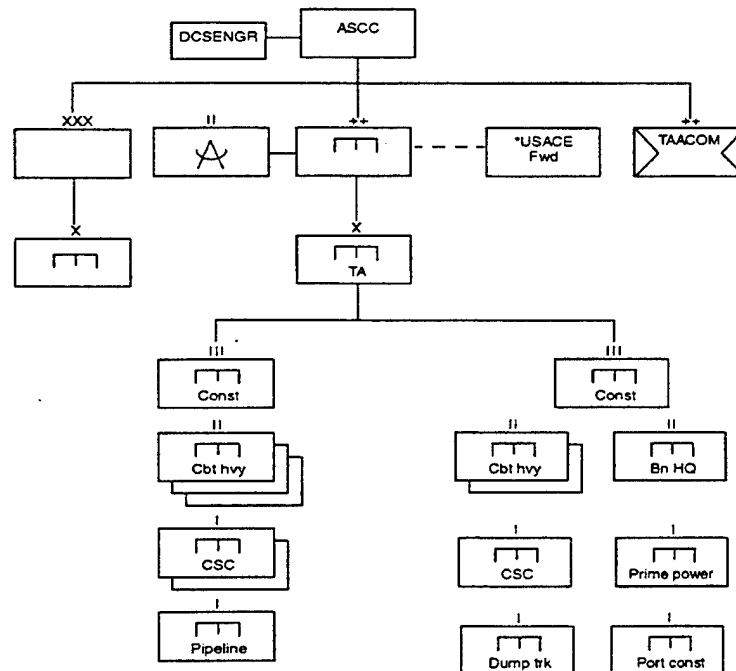

FIGURE 1 - NOTIONAL ASCC THEATER ENGINEER LAYDOWN

The ENCOM is tailored to provide support based on the overall ASCC mission and situation. For example, in developing theaters, emphasis on lines of communication construction, real estate acquisition, base camp construction, force protection, and topographic support will require an ENCOM that is heavily weighted with construction and topographic engineering capabilities.

The ENCOM has a direct linkage to the U. S. Army Corps of Engineers (USACE) through a USACE forward element that is under the operational control of the ENCOM. This gives the ENCOM the expertise and authority to conduct real estate acquisitions, and to execute construction contract management. The USACE element also brings access to the various Corps laboratories through tele-engineering.

The most important capability that the ENCOM brings to the ASCC is its ability to conduct construction planning and management. The ENCOM manages troop and contract construction, integrates prioritized construction projects from all component commanders, prioritizes U. S. requests for host nation construction support, and manages the procurement of construction materials.<sup>6</sup>

Since these management responsibilities require extensive knowledge of the area and detailed plans prior to execution, the ENCOM clearly must be brought aboard early in the theater planning process. This is especially true for contingency planning. However, since the two ENCOMs in the force structure (412<sup>th</sup> ENCOM and 416<sup>th</sup> ENCOM) are in the U. S. Army Reserve, this has proven to be a challenge.

The ENCOM can have a significant role in joint operations. Should the Unified Commander in Chief (CINC) establish a Regional Contingency Engineering Manager (RCEM) to control all theater-level engineering, and appoint the ASCC as the RCEM, the ENCOM can perform this mission if so ordered by the ASCC.<sup>7</sup> The establishment of a RCEM is particularly useful in situations where one service has the preponderance of engineering capability, or where the CINC lacks the capability to control theater level engineering with his own assets.

One last note about the ASCC engineer laydown shown in Figure 1 is that doctrinally there is a staff engineer (DSCENGINEER) on the ASCC staff that is separate from the ENCOM. This staff engineer, unlike an ENCOM, is not a commander of engineer forces, and lacks the means to do detailed construction management required for major operations.

In conclusion, the ENCOM, as specified in Army doctrine, is an organization that provides critical engineer command and control, construction management, real estate acquisition, and topographic support to the ASCC as well as to joint forces if so ordered. From this, one could conclude that this organization should be invaluable in the event of a contingency operation that requires major engineer support.

## **THE ROLE OF THE ENCOM IN RECENT CONTINGENCY OPERATIONS**

As mentioned earlier the doctrinal mission, organization, and responsibilities of the ENCOM would indicate that this organization should be a key player in contingency operations that require significant

engineer support. Two recent contingencies that included major engineer efforts will be analyzed to determine if this was in fact the case. These contingencies are Operation Desert Shield/Desert Storm, and Operation Joint Endeavor.

#### OPERATION DESERT SHIELD/DESERT STORM

On 2 August 1990, Iraqi forces invaded Kuwait, thus beginning the Persian Gulf War. In many ways, however, the involvement of an ENCOM in this region began much earlier. In 1983, the 416<sup>th</sup> ENCOM, headquartered in Chicago, IL, was designated as the wartime construction planning headquarters for the Southwest Asia Theater.<sup>8</sup> As such, the 416<sup>th</sup> ENCOM began to build a repository of information concerning existing facilities and engineering requirements for that area.<sup>9</sup>

At the outbreak of the war the need for a large engineer effort to support the forces became evident. However, despite this need, the 416<sup>th</sup> ENCOM was not activated. Instead, Third Army relied on a staff engineer section of eight officers, none of which was a general officer, to conduct the initial theater-level planning.<sup>10</sup>

The 20<sup>th</sup> Engineer Brigade of the XVIII Airborne Corps was the first senior engineer headquarters to arrive in theater. The brigade commander, Colonel Robert Flowers, and his advance party arrived in Saudi Arabia on 4 August 1990.<sup>11</sup> As such, the 20<sup>th</sup> Engineer Brigade found itself tasked with two separate missions. First, it retained its primary mission to support the XVIII Airborne Corps. Second, it also had the mission of planning and executing theater army engineer missions. These included constructing main supply routes, heliports, improving base camps, drilling wells, and providing crash fire rescue.<sup>12</sup> The 20<sup>th</sup> Engineer Brigade was clearly not staffed to execute these two missions. It did not have a contract element, a staff judge advocate, a robust design capability, and all the elements needed to manage engineer operations at theater army level. Adding to the pressure on the 20<sup>th</sup> Engineer Brigade while it served as both a Corps and Theater engineer headquarters was the standup of a Provisional Support Command under Major General Pagonis. This new headquarters added additional demands for engineer support such as constructing logistics bases and improving basecamps.

By September General Pagonis reported that his staff and the 20<sup>th</sup> Engineer Brigade were being overwhelmed by the amount of facilities work required. There was a tremendous need for both horizontal and vertical construction as requirements for ammunition supply points, main supply route maintenance, site preparation, and helipads mounted.<sup>13</sup> Despite the pressing need for a theater level engineer headquarters, the 416<sup>th</sup> ENCOM was not activated. Part of the reason for this may have been "the perception that Headquarters, Department of the Army, was discouraging the call up of Reserve general officers".<sup>14</sup>

Finally, on 15 October 1990 a 25-man detachment of the 416<sup>th</sup> ENCOM was activated, under the command of Colonel Alan Berg. This element arrived in Saudi Arabia on 30 October 1990.<sup>15</sup> However, instead of becoming a major subordinate headquarters under the ASCC, this detachment was placed under the command of Major General Pagonis. Later, General Pagonis, now commanding the 22d

Support Command, referred to the 416<sup>th</sup> advance party "his engineer command".<sup>16</sup> This resulted in the 416<sup>th</sup> ENCOM advance party receiving missions more closely resembling logistics support instead of theater engineer construction management.

When the decision was made in November 1990 to deploy VII Corps to the theater, the resulting increase in Echelons Above Corps (EAC) engineer support doubled already existing requirements and finally drove the activation of the entire 416<sup>th</sup> ENCOM headquarters. It was activated on 29 November 1990, and arrived at Riyadh on 11 December 1990.<sup>17</sup> Upon its arrival, the 416<sup>th</sup> ENCOM became a major subordinate command under the ASCC. Its commander, Major General Terrence Mulcahy, eventually commanded all EAC engineers totaling over 5000 troops, and represented approximately 20,000 engineer troops in theater assigned to the VII and XVIII Corps.<sup>18</sup> The final army engineer command and control structure for Operation Desert Shield/Desert Storm is shown in Table 1<sup>19</sup>.

	EAC	VII	XVIII
Brigade Headquarters	1	1	1
Group Headquarters	0	3	3
Combat Heavy Battalion	2	3	4
Corps Combat (Mechanized)	0	5	0
Corps Combat (Wheeled)	0	2	5
Corps Combat Support Equipment Company	2	2	1
Construction Support Company	3	0	0
Pipeline Construction Company	3	0	0
Medium Girder Bridge Company	0	1	1

TABLE 1 - DESERT SHIELD/DESERT STORM ENGINEER STRUCTURE

A critical review of the performance of the 416<sup>th</sup> ENCOM shows that while it performed admirable service, its contributions were limited due to its late activation and arrival in theater. This late activation precluded it from proactively planning and controlling EAC engineer operations, and resulted in this burden being placed on the 20<sup>th</sup> Engineer Brigade. Additionally, the lack of a general officer in the 416<sup>th</sup> ENCOM's advance party contributed to this element's placement under the command of a logistician instead of functioning as a major subordinate command in its own right. Because the 416<sup>th</sup> ENCOM had no active duty general officer or staff element, it was forced to wait until activation before it could make substantial contributions. Unfortunately, much of the engineer planning, construction management, and command and control requirements at EAC occurred early in the operation, and before the activation of the 416<sup>th</sup> ENCOM.

Additionally, the 416<sup>th</sup> ENCOM's support to other services was non-existent. This resulted from General Schwarzkopf's decision not to establish a RCEM. Instead, each service was responsible for its

own engineering and construction support. General Schwarzkopf did establish a regional contingency construction management team, under the direction of the CENTCOM engineer. In addition to the CENTCOM engineer and his staff, this team included engineers representing each service.<sup>20</sup> The small size and ad hoc nature of this team made it less effective than had the 416<sup>th</sup> ENCOM been designated as the RCEM.

#### OPERATION JOINT ENDEAVOR

Operation Joint Endeavor, and the implementation of the Dayton Peace Accord for Bosnia-Herzegovina began on 20 December 1995. The majority of U. S. Forces for this operation were assigned to Task Force Eagle. This organization consisted of over 18,000 U. S. soldiers, mostly from the 1<sup>st</sup> Armored Division. Additional units from Denmark, Estonia, Finland, Iceland, Latvia, Lithuania, Norway, Poland, Russia, Sweden, and Turkey brought the total strength of Task Force Eagle to over 25,000 personnel.<sup>21</sup>

From an engineer standpoint the support required for this organization was enormous. Missions included the maintenance of over 3000 kilometers of roads and bridges, the upgrade of all main supply routes in theater, the construction of over 30 base camps for 20,000 soldiers, airmen, and civilians, and the establishment of freedom of movement through 12,000 minefields.<sup>22</sup> These were in addition to the major mission of crossing the Sava River, which generated intense media coverage at the start of the operation.

To accomplish these missions an engineer force of over 5,400 soldiers was assembled. Some 2,900 of these were American engineers, while an additional 2,500 combat engineers, either assigned to or supporting Task Force Eagle came from Russia, Poland, Norway, Sweden, Germany, Italy, Turkey, Greece, Ukraine, Pakistan, and Romania.<sup>23</sup> Some of the commanders of these forces were full colonels.

The American engineers consisted of two engineer battalions from the 1<sup>st</sup> Armored Division, a corps combat engineer battalion, a corps combat heavy battalion, two medium girder bridge companies, two combat support equipment companies, an explosive ordnance battalion, a Naval Mobile Construction (Seabee) battalion, and an Air Force Red Horse construction squadron.<sup>24</sup> Additionally, the U. S. Army Corps of Engineers provided a Contingency Real Estate Support Team (CREST), and Brown and Root Services Corporation provided engineering and construction support under the Logistics Civilian Augmentation Program (LOGCAP).<sup>25</sup>

The sheer size, complexity, and scope of responsibilities for this engineer organization would seem to more than justify the activation of at least a portion of an ENCOM, with a general officer in charge. Yet, like the beginning of Operation Desert Shield, this was not the case. Instead, command and control of the engineer forces generally fell to the 1<sup>st</sup> Armored Divisional Engineer Brigade. The limitations of this 55-man headquarters became apparent almost immediately during the crossing of the Sava River. Because float bridging is not organic to the division, expertise in the technical aspects of bridge construction is limited in the divisional engineer brigade. This, in conjunction with the unexpected surge

in the Sava River, created major problems for the engineers. Bridge construction began on 20 December 1995, but was not completed until 31 December 1995.<sup>26</sup> Furthermore, the requirement for the 1<sup>st</sup> Armored Division Engineer Brigade to focus on the river crossing operations undoubtedly detracted from its ability to plan for the follow on operations of base camp construction and route repair.

Once the Sava River was crossed the magnitude of the base camp construction problem became apparent. The variety and multitude of sustainment tasks involved in maintaining life support areas for over 20,000 troops for 365 days was overwhelming for an MTOE divisional engineer brigade headquarters.<sup>27</sup> To overcome this shortfall Task Force Eagle created an ad hoc organization called the Base Camp Coordinating Authority (BCCA). This 8-man organization, led by an engineer lieutenant colonel, reported to the Task Force Eagle chief of staff and assistant division commander for support. The BCCA initially was resourced from assets from the 1AD Engineer Brigade, but later was resourced from reserve and active component Temporary Change of Station (TCS) personnel. The BCCA eventually controlled the Contingency Real Estate Team, an environmental engineer, and the Base Camp Assistance Team (BCAT), which provided technical assistance to base camp mayors and senior tactical commanders. The most important mission of the BCCA, however, was to provide engineer oversight to the LOGCAP contractor.

Further complicating the problem for engineers at the theater level was the need to construct an Intermediate Staging Base (ISB) in Taszar, Hungary. Since the ISB was outside the Task Force Eagle Boundary, the 1<sup>st</sup> Armored Division Engineer Brigade clearly could not oversee this massive project.

The absence of an engineer general officer to oversee operations became apparent to LTG John Abrams, the Commanding General of V Corps. To rectify this problem he called upon MG Flowers, the same man who commanded the 20<sup>th</sup> Engineer Brigade during the Gulf War, to leave his job as Commanding General, Lower Mississippi Valley Division, USACE, for a period of 3 months in order to provide engineer general officer oversight to operations in Hungary and Bosnia. General Flowers had just recently served as an assistant division commander under General Abrams in Korea. Their close relationship in Korea allowed MG Flowers

to earn the trust and confidence of LTG Abrams. Undoubtedly this was the major reason why LTG Abrams selected MG Flowers to assist in Operation Joint Guard. The final engineer command and control structure for Operation Joint Endeavor is shown in Figure 2. Note that this was a combined (multinational) and joint engineer operation.

In analyzing the development and performance of the engineer

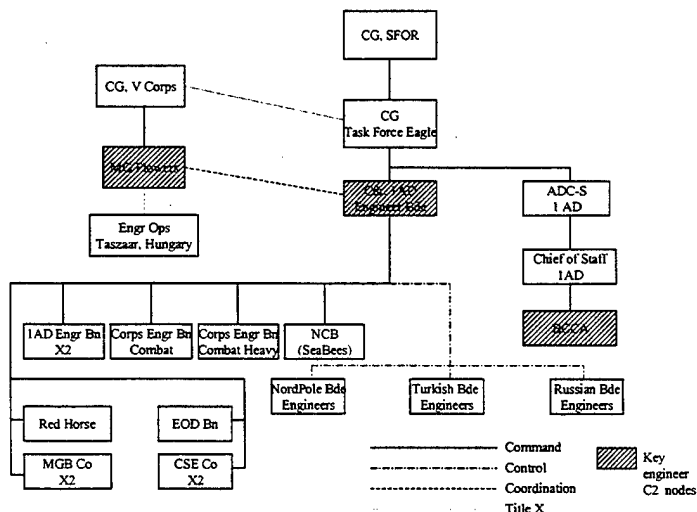

FIGURE 2 - OPERATION JOINT ENDEAVOR ENGINEER STRUCTURE

command and control structure used in Operation Joint Endeavor, it is easy to see that it could detract from unity of effort. The 1<sup>st</sup> Armored Division Engineer Brigade did not work for General Flowers, but instead worked for the Commanding General of Task Force Eagle. The Base Camp Coordinating Agency did not work for the Engineer Brigade, but worked for the Task Force Eagle Chief of Staff. MG Flowers did not work for the Commanding General of Task Force Eagle, but instead worked for the Commanding General of V Corps. This arrangement could obviously lead to conflicting priorities and directives. Also, the sheer size and complexity of the mission was overwhelming to an MTOE divisional engineer brigade, which lacks organic construction management capability.

Despite the obvious requirement for an ENCOM, none was activated. The only contribution from an ENCOM was the activation of seven Facilities Engineer Teams from the 416<sup>th</sup> ENCOM.<sup>28</sup> Instead, the army created an ad hoc organization, with an Active Component engineer general officer, an active component divisional engineer brigade headquarters, and a non-standard organization called the Base Camp Coordinating Agency. One can only conclude from this that the reason for the lack of a much larger ENCOM participation was the fact that it has no active duty personnel. This made it much harder to activate and deploy, and prevented the building of trust and confidence between the ENCOM and senior leaders in theater.

#### **THE FIX—MAKING ENCAMS MORE RELEVANT**

When one considers the relevancy of the ENCAMS as they are currently organized, it appears that they are mostly geared towards the higher end of the spectrum of conflict. Because they are located in the U. S. Army Reserve, the ENCAMS need time and the approval of the President (PSRC) in order to be activated. These conditions are most likely to be met in a major theater of war scenario, although, as the case of Operation Desert Shield and Desert Storm shows, problems can occur even in these scenarios. Unfortunately, our current National Security Strategy and actual events that have occurred since the end of the Cold War indicate that participation in peacekeeping operations, disaster relief, and other lower levels of conflict is much more likely. These operations, although lower on the spectrum of conflict in terms of intensity of combat, often require major engineer support. Thus, the ENCOM must be relevant across the entire spectrum of conflict.

In order for this to happen the ENCOM structure must change. There are three changes to the ENCOM that will go a long way towards fixing the deficiencies noted earlier. First, a portion of the ENCOM, to include a general officer, must be placed on active duty. This element would have representatives from key elements of the command post, to include specialists from contracting, design, and planning cells. Their focus initially would be on the reception, staging, onward movement, and integration of forces, and on planning for future operations. This is the only way that the ENCOM can establish the personal trust and confidence of the ASCC and can participate in the planning process early in the operation. Second, these active duty generals and staff must be linked to a specific geographic area and the corresponding ASCC. This could be done by dual hatting the general officer as the ASCC engineer staff officer, reporting directly to the ASCC commander. Thus four active duty generals would

be required, one for each geographic CINC. Third, this active duty portion of the ENCOM must be proficient at commanding joint engineer forces. In this role, it must have the ability to be assigned to a Joint Task Force at two or three star level, as well as working directly for the geographic CINC as the Joint Theater ENCOM.

These three changes would make the ENCOM a highly responsive, versatile, and extremely capable headquarters that could play a major role in virtually any contingency operation. To demonstrate this, Operation Desert Shield/Desert Storm and Operation Joint Endeavor will be revisited to show how this new structure would have led to a much better command of engineer forces and thus better support to commanders on the ground.

#### DESERT SHIELD/STORM REVISITED

The existence of an active duty engineer general officer dual hatted as the engineer staff officer on the ARCENT staff and as the Deputy Commanding General of the 416<sup>th</sup> ENCOM would have enormously simplified the command and control of theater-level engineer assets for this operation. Instead of waiting almost four months until being activated, this element would have arrived in theater concurrently with the 20<sup>th</sup> Engineer Brigade on 4 August 1990. Once on the ground it would have assumed responsibility for EAC engineer missions and command of all EAC engineer forces. Thus, this active duty portion of the ENCOM would have greatly reduced the burden on the 20<sup>th</sup> Engineer Brigade.

Furthermore, because this general officer would have been on active duty and working directly for the ASCC prior to the outbreak of the conflict, he would have developed the necessary trust to continue to work directly for the ASCC once the operation began. This would have allowed the ENCOM to more effectively address and integrate engineer missions throughout the theater, instead of working for a logistics commander.

Additionally, this portion of the ENCOM, by being in theater and a part of the planning process from the beginning of the operation, would have been much better able to coordinate with the remainder of the ENCOM. This would have reduced the time needed to bring the reserve portion of the ENCOM up to speed once it was activated.

In summary, the proposed ENCOM structure, by having an active duty general officer and supporting staff, would have greatly improved the command and control of theater-level engineer forces during Operation Desert Shield/Desert Storm. This would have reduced the burden on the 20<sup>th</sup> Engineer Brigade, prevented the undue weighting of engineer effort towards logistics support, and provided better engineer support to the theater as a whole.

#### OPERATION JOINT ENDEAVOR REVISITED

The proposed ENCOM structure would have greatly simplified the command and control of engineers in Operation Joint Endeavor. In this case, the active duty portion of the ENCOM could have been assigned directly to the Commanding General, Task Force Eagle. As such, it could have commanded and controlled all combined and joint engineer operations in the Task Force Eagle area of



## **CONCLUSION—THE WAY AHEAD**

The analysis of the performance of the ENCOM during Operations Desert Shield/Desert Storm and Operation Joint Endeavor indicates that the doctrinal missions and responsibilities of the ENCOM have not changed. Unfortunately, the current ENCOM structure that has the entire command in the reserve and not on active duty prevents the ENCOM from actually executing these missions. This is particularly true for those missions on the lower end of the spectrum of conflict, even though they require substantial engineer support. The lack of an active duty general officer and staff limits the ability of the ENCOM to gain the trust and confidence of the ASCC, and limits the responsiveness of the ENCOM to participate in contingency operations. Since these types of operations are the most likely to occur in the near future, the ENCOM as it now is structured continues to face issues of relevancy.

In order for the ENCOM to become more relevant, three major changes to its structure must occur. First, each ENCOM must have two active duty general officers and assigned staffs. Second, these general officers and staffs must be directly linked to a specific geographic CINC. This could be done by dual hatting each general officer as the staff engineer on the ASCC staff, and as a Deputy Commanding General of the ENCOM. The result would be two active duty Deputy Commanding Generals in each of the two ENCOMs. Third, the ENCOM must be able to command joint engineer forces. In some cases, this means that the ENCOM would be dual hatted as the ASCC engineer commander, and as the CINC's joint theater engineer commander.

These proposed changes to the ENCOM structure do come with a cost. The biggest cost is the need for additional active duty engineer general officers. Since USAREUR already has an active component engineer general officer serving as the staff engineer, this proposal would require three additional general officers—one for each of the other three geographic CINCs. By dual hatting these spaces as both ASCC and joint engineer commands, we could gain support from the CINCs for their creation.

Once created, these positions should be filled by reserve component engineer general officers called to active duty for a period of two to three years. This would allow these general officers to develop the trust and confidence of the ASCC and the CINC needed in order for them to perform their duties.

In conclusion, the types of missions the United States faces now and for the next decade demand an ENCOM that is structured to respond to the entire spectrum of conflict. The proposed new ENCOM structure gains a tremendous increase in flexibility and responsiveness that far outweighs the costs associated with it, and will make it relevant to the post Cold War world.

WORD COUNT = 4886



## ENDNOTES

<sup>1</sup> William J. Clinton, A National Security Strategy for a New Century (Washington, D. C.: The White House, December 1999), 5, 14, 20.

<sup>2</sup> Department of the Army, Engineer Operations, Field Manual 5-100 (Washington, D.C.: U.S. Department of the Army, 27 February 1996), 2-4.

<sup>3</sup> Department of the Army, United States Army Reserve in Operation Desert Storm, Engineer Support at Echelons Above Corps: The 416<sup>th</sup> Engineer Command (Washington D.C.: U.S. Department of the Army, 18 May 1992), 12.

<sup>4</sup> Department of the Army, Engineer Operations, 2-4.

<sup>5</sup> Ibid, 2-5.

<sup>6</sup> Ibid, 5-4.

<sup>7</sup> Ibid, 2-6.

<sup>8</sup> Department of the Army, United States Army Reserve in Operation Desert Storm, Engineer Support at Echelons Above Corps: The 416<sup>th</sup> Engineer Command, 6.

<sup>9</sup> Ibid, 7.

<sup>10</sup> Ibid, 8.

<sup>11</sup> Ibid, 8.

<sup>12</sup> Janet A. McDonnell, Supporting the Troops: The U. S. Army Corps of Engineers in the Persian Gulf War (Alexandria, Va.: Office of History, U. S. Army Corps of Engineers, 1996), 9.

<sup>13</sup> Ibid, 22.

<sup>14</sup> Department of the Army, United States Army Reserve in Operation Desert Storm, Engineer Support at Echelons Above Corps: The 416<sup>th</sup> Engineer Command, 10.

<sup>15</sup> Ibid, 10.

<sup>16</sup> Ibid, 11.

<sup>17</sup> Ibid, 12.

<sup>18</sup> Ibid, 1.

<sup>19</sup> McDonnell, 26.

<sup>20</sup> McDonnell, 89-90.

<sup>21</sup> William L. Nash, Task Force Eagle After Action Report, Volume I (n. p., 1 June 1997), I-1.

<sup>22</sup> Ibid, 605.

<sup>23</sup> Ibid, 605.

<sup>24</sup> Ibid, 605.

<sup>25</sup> Ibid, 569.

<sup>26</sup> Ibid, 560.

<sup>27</sup> Ibid, 572.

<sup>28</sup> Robert Heineheiner@wood.army.mil, "ENCOMs", electronic mail message to David Kingston <david.kingston@carlisle.army.mil>. 18 November 1999.

## BIBLIOGRAPHY

- Byers, Timothy A., Lieutenant Colonel. Joint Engineers: Full Spectrum Support-From Peace to War. Carlisle Barracks, PA: U. S. Army War College, 7 April 1999.
- Clinton, William J. A National Security Strategy for a New Century. Washington, D. C.: The White House, December 1999.
- Heine Robert, Brigadier General [heiner@wood.army.mil](mailto:heiner@wood.army.mil). "ENCOMs." Electronic mail message to David Kingston [david.kingston@carlisle.army.mil](mailto:david.kingston@carlisle.army.mil). 18 November 1999.
- McDonnell, Janet A. Supporting the Troops: The U. S. Army Corps of Engineers in the Persian Gulf War. Alexandria, VA: Office of History, U. S. Army Corps of Engineers, 1996.
- Nash, William L. Task Force Eagle After Action Report, Volume 1. N. p., 1 June 1997.
- Pagonis, William G., Lieutenant General. Moving Mountains: Lessons in Leadership and Logistics from the Gulf War. Boston, MA: Harvard Business School Press, 1992.
- U. S. Department of the Army. Engineer Operations. Field Manual 5-100. Washington, D. C.: U. S. Department of the Army, 27 February 1996.
- U. S. Department of the Army. Engineer Operations: Echelons Above Corps. Field Manual 5-116. Washington D. C.: U. S. Department of the Army, 9 February 1999.
- U. S. Department of the Army. United States Army Reserve in Operation Desert Storm, Engineer Support at Echelons Above Corps: The 416<sup>th</sup> Engineer Command. Washington, D. C.: U. S. Department of the Army, 18 May 1992.
- U. S. Joint Chiefs of Staff. Engineer Doctrine for Joint Operations. Draft Joint Publication 3-34. Washington, D. C.: U. S. Joint Chiefs of Staff, 15 November 1999, Preliminary Coordination.
- U. S. Joint Chiefs of Staff. Joint Doctrine for Civil Engineering Support. Joint Publication 4-04. Washington, D. C.: U. S. Joint Chiefs of Staff, 26 September 1995.
- Young, Don C. Enhancing Engineer Jointness and Future Joint Engineer C2 for Global Engagement. Carlisle Barracks, PA: U. S. Army War College, 7 April 1999.