

AFWAL-TM-85-204-FIMN

**DEVELOPMENT AND COMPATIBILITY OF
FLOW SEEDING TECHNIQUES FOR LV
MEASUREMENTS IN A DIVERSITY
OF RESEARCH TEST FLOWS**

by

Daniel M. Parobek
Aeromechanics Division
Flight Dynamics Laboratory
Wright-Patterson AFB, Ohio

and

David L. Boyer and
Gary A. Clinehens
Technology Scientific Services, Inc.
Dayton, Ohio

June 1985

Approved for public release; distribution unlimited.

**AERONAUTICAL LABORATORIES
FLIGHT DYNAMICS LABORATORY
AEROMECHANICS DIVISION
EXPERIMENTAL ENGINEERING BRANCH
WRIGHT-PATTERSON AFB, OHIO 45433**

20000512 054

**Reproduced From
Best Available Copy**



FOREWORD

This Technical Memorandum was prepared by D. M. Parobek of the Aeromechanics Division, Air Force Wright Aeronautical Laboratories, Wright-Patterson Air Force Base, Ohio and D. L. Boyer and G. A. Clinehens of Technology Scientific Services, Inc, Dayton, Ohio. The technical developments were performed as an element under Work Unit Number 24041307, "Development of Testing Techniques and Flow Diagnostics to Advance Aerodynamic Ground Simulation," and contract F33601-82-D0088.

This Technical Memorandum has been reviewed and is approved.

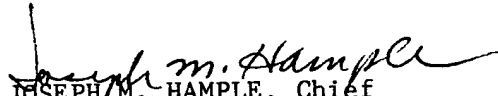
JOSEPH M. HAMPLE, Chief
Experimental Engineering Branch
Aeromechanics Division

ABSTRACT

Particle seeding techniques and generations have been developed to provide scattering centers for laser velocimeter data acquisition in a diversity of research test flows at the Aeromechanics Division of the Air Force Wright Aeronautical Laboratories. The facility flows range from the subsonic through hypersonic regimes, including aerothermal flow and a water tunnel. The compatibility and environmental problems with introducing seeding material into tunnel flows are discussed. Exploratory findings of natural particulate matters are presented. An in-house developed high pressure particle generator is described. Applications of a number of generating techniques to these tunnels include dispersion and data rate information in the test sections. Particle sizing measurements are presented with a variety of fluids, fluid viscosities, and generators.

TABLE OF CONTENTS

PAGE

I	INTRODUCTION	1
II	TUNNEL DESCRIPTIONS	2
III	NATURAL PARTICULATES	5
IV	FACILITY OPERATIONAL REQUIREMENTS FOR ARTIFICIAL SEEDING	7
V	SEEDING MATERIAL	9
VI	SEED GENERATION	12
VII	PARTICLE SIZING	14
VIII	DISPERSION AND DATA RATES AT TEST SECTION	21
IX	CONCLUSIONS	28
X	THRUSTS AND CONTINUING PROGRAM	30
XI	REFERENCES	32
XII	ACKNOWLEDGEMENTS	33

LIST OF ILLUSTRATIONS

<u>FIGURE</u>	<u>TITLE</u>	<u>PAGE</u>
1	TWO-FOOT TRISONIC GASDYNAMIC FACILITY	34
2	9" SELF-ADAPTIVE WALL TRANSONIC WIND TUNNEL	35
3	HIGH REYNOLDS NUMBER FACILITIES	36
4	VERTICAL WIND TUNNEL.	37
5	6" PROTOTYPE WATER TUNNEL	38
6	DISA LV SYSTEM FOR VERTICAL WIND TUNNEL	39
7	CORROSION IN VWT FROM WATER-GLYCERINE SEED	40
8	TWO STAGE ATOMIZER.	41
9	SONIC NOZZLE AND HIGH PRESSURE INJECTORS	42
10	HIGH PRESSURE SEEDER.	43
11	PARTICLE SIZING TEST SETUP.	44
12	SONIC NOZZLE PARTICLE SIZING.	45
13	SONIC NOZZLE PARTICLE SIZING.	46
14	SONIC NOZZLE PARTICLE SIZING.	47
15	SONIC NOZZLE PARTICLE SIZING.	48
16	MACH 6 HIGH PRESSURE SEEDER PARTICLE SIZING	49
17	MACH 6 HIGH PRESSURE SEEDER PARTICLE SIZING	50
18	MACH 6 HIGH PRESSURE SEEDER PARTICLE SIZING	51
19	MACH 3 HIGH PRESSURE SEEDER PARTICLE SIZING	52
20	MACH 3 HIGH PRESSURE SEEDER PARTICLE SIZING	53
21	MACH 3 HIGH PRESSURE SEEDER PARTICLE SIZING	54
22	HIGH PRESSURE SEEDER PARTICLE SIZING.	55

<u>FIGURE</u>	<u>TITLE</u>	<u>PAGE</u>
23	TWO STAGE ATOMIZER PARTICLE SIZING.	56
24	TWO STAGE ATOMIZER PARTICLE SIZING.	57
25	TWO STAGE ATOMIZER PARTICLE SIZING.	58
26	TWO STAGE ATOMIZER PARTICLE SIZING.	59
27	TWO STAGE ATOMIZER PARTICLE SIZING.	60
28	PARTICLE VELOCITIES IN THE SEEDER PLUMES.	61
29	SINGLE COMPONENT LV FORWARD AND BACKSCATTER IN TGF.	62
30	SINGLE COMPONENT LV BACKSCATTER IN TGF.	63
31	SEEDER INSTALLATIONS IN TGF PLENUM.	64
32	SEED INJECTOR CONFIGURATIONS IN TGF	65
33	LOCAL SEEDING IN TGF WITH SONIC NOZZLE.	66
34	LOCAL SEEDING IN TGF WITH SONIC NOZZLE.	67
35	LOCAL SEEDING IN TGF WITH SONIC NOZZLE.	68
36	DATA RATES IN TGF BOUNDARY LAYER WITH SONIC NOZZLE SEEDING AND LV IN FORWARD AND BACKSCATTER MODES	69
37	LOCAL SEEDING IN TGF WITH HIGH PRESSURE SEEDER.	70
38	LOCAL SEEDING IN TGF WITH HIGH PRESSURE SEEDER.	71
39	SINGLE COMPONENT LV USED IN 6" PROTOTYPE WATER TUNNEL	72
40	VELOCITY MAP OF LATERAL PLANE AT AXIAL CENTER OF 6"	73
	PROTOTYPE WATER TUNNEL TEST SECTION	

I INTRODUCTION

This paper relates developments and findings of particulate generation, sizing, and dispersion for use in the Flight Dynamics Laboratory's (FDL) research tunnels. However, it will also emphasize the inter-related facility issues; living with artificial seeding in the "total" wind tunnel environment. These issues, although principally technical in nature, also involve human factors. They include contamination of the facility, deleterious effects to the facility environmental systems and instrumentation, facility safety, health and environmental factors, operational and test schedule restrictions, and resource penalties. This combination of related concerns, coupled with the aerodynamicist's desire to map velocities in very difficult seeding regions, such as near the center of vortices, at wall regions of boundary layers, and in highly turbulent mixed flows, imposes difficult requirements both for seeding and for Laser Velocimeter (LV) systems. The performance shortfall of today's LV systems is their inability to detect and use signals from very small submicron particles, and their limited ability to reject optical noise. These limitations can be somewhat compensated for by introducing overly large particle seeding densities to obtain minimally acceptable data rates. This tendency increases further as simultaneous component measurements increase to two and three.

It is within these combined guidelines that the Aerosol Generation Development Program at FDL has proceeded in the last several years. This work was accomplished parallel with improvements in optical data acquisition and data management areas of LV performance. The facilities toward which the seeding developments have been carried out are the Trisonic Gasdynamic Facility (TGF), the 9" Self-Adaptive Wall (SAW) Transonic Tunnel, the Mach 3 and Mach 6 High Reynolds Number Facilities (HRNF), the Vertical Wind Tunnel, and the 6" Prototype Water Tunnel. In each case, a nominal flow seeding capability has been demonstrated and actually used successfully to accomplish aerodynamic testing, including LV measurements. However, as the report will bear out, while much has been accomplished, more performance improvements would not only improve LV data acquisition, but also improve facility livability with the seeding process.

II TUNNEL DESCRIPTIONS

Trisonic Gasdynamic Facility

The Trisonic Gasdynamic Facility is of continuous closed loop operation. Figure 1 illustrates the layout and key test parameters. The subsonic and supersonic test sections are approximately 2' x 2', while the transonic range is covered by installation of an insert of 15" x 15" test section size. The internal flow circuit includes an 8' x 8' stagnation section fitted with both screens and honeycomb, turning vanes at the end of the diffuser, an axial flow compressor, a dryer, and two sets of high-density finely finned coiling coils operating at ambient water temperatures. This facility operates on a continuous heavy 1-shift schedule. Considerable LV testing is conducted in this facility. Flow velocities in the stagnation section range from 15 to 45 feet per second. Compressor outlet temperature ranges to 400°F.

9" Self-Adaptive Wall Transonic Wind Tunnel

This blowdown facility of 9" square test section was specially built to support research of Adaptive Wall techniques. It is not currently operational. It is shown in Figure 2 and is included in this report because of seeding development and LV work which was influential in shaping the seeding program. The facility operated at stagnation pressures to four atmospheres with a high contraction ratio. Screens were installed in the six-foot diameter plenum.

Mach 3 High Reynolds Number Facility

This blowdown test leg shown in Figure 3 operates at stagnation pressures to 560 psi directly from ambient temperature storage air. It has a closed test section with an atmospheric exhaust. A honeycomb and several screens are located in the stagnation section. The operation velocity in this region ranges from 20 to 40 feet per second. A flow transition is

made from the circular stagnation section to the rectangular nozzle inlet and the square test section via a petal type geometry roughly shown in the illustration.

Mach 6 High Reynolds Number Facility

An electric heated steel ball storage heater furnishes this atmospheric exhaust blowdown facility with 1150° R air at stagnation pressures to 2100 psi. The test leg is also shown in Figure 3. It includes honeycomb and screens in the circular stagnation section which operates at velocities of 28 to 52 feet per second. The open jet test flow is of 12-inch diameter.

Vertical Wind Tunnel

The flow circuit of the FDL updraft closed-circuit vertical wind tunnel is shown in Figure 4. The 12' diameter open test section has a maximum velocity of 130 feet per second. The tunnel is fan driven and built of reinforced concrete. The safety net shown below the test section is not used in every test, however it does degrade the performance to a degree.

6" Pilot Water Tunnel

This facility, shown in Figure 5, is of intermittent gravity operation and constructed of transparent plastic. A major purpose of this tunnel is for development of instrumentation, diagnostics, and flow straightening techniques as apply to a two-foot square water tunnel now under construction. Maximum flow velocity is approximately 0.36 feet per second.

III NATURAL PARTICULATES

The characteristics and possible usefulness of existing tunnel particulates for LV measurements has been examined in each of the FDL facilities. Entrapped atmospheric air contains a wide variety of particles. Sources within the tunnel and connected environmental systems include; rust and other forms of corrosion; paint; welding scale; desiccant dust; lubricants; solvents; erosion of seals, gaskets, screens, honeycomb; condensate, etc.

The time history of the natural particle size distribution and particle density within a tunnel are important to assess in relation to the performance of the designated LV system and its data acquisition rates.

Trisonic Gasdynamic Facility

For example, considerable investigation was made in a "very clean" Trisonic Gasdynamic Facility for the possibility of utilizing existing seed rather than contaminating the circuit (References 1, 2 and 3). Clean, as used in this instance, included no trace of liquid film or dry marks from fluids, and no visible solid particle buildup throughout the circuit. Analysis of the flow with both a fringe LV and a Laser Transit Anemometer (LTA) indicated high data rates for the first few seconds of running, followed by 10 to 15 minutes of much lower usable data rates, after which time the signal was lost. Analysis of the LTA performance assured that the known remaining very high densities of particles were below .15 μm size.

9" Self-Adaptive Wall Transonic Tunnel

Much of the 9" Self-Adaptive Wall Transonic Tunnel circuit was newly built when LV testing was initiated. This blowdown facility of relatively high mass flow produced sufficient particles for velocity measurements for typical runs to 45 seconds (Reference 3). However, the particle concentrations were not uniform, and it was particularly difficult to make flow angle measurements with an LTA. In this facility, the character and long

evity of the particle field indicated that the dominant contributions were from rust, scale, and slag of the new supply leg connecting an existing bottle farm to the existing stagnation plenum.

Mach 3 and Mach 6 High Reynolds Number Facilities

Both these facilities and their pumping and high pressure storage farms have been used consistently over a long number of years. Therefore, the test flows should be low in particulates. This proved the case, with the unheated flow of the Mach 3 having even less than that of the Mach 6. The Mach 6 storage heater apparently contributes particles due to the constant thermal cycling. It was noted that their size was relatively large, and that useful free stream data rates were a low 10 to 20 per second (Reference 4).

Vertical Wind Tunnel

This tunnel has huge areas of exposed concrete forming the counter flow circuit. Since it is vertically oriented, almost everything falls out on the floor of the stagnation region, and contrary to visual appearance of cleanliness, it is a "dirty" tunnel in LV terms. However, the natural seed has a very broad particle size range, and it is inadequately populated in the particle sizes required. Very high particle densities are required to overcome the noise and insensitivity problems associated with the long focal length optics and path length. A DISA two-component, on-axis LV system, shown in Figure 6, is used in this facility.

6" Prototype Water Tunnel

The extremely low velocities of these flows present a different seeding problem. A high density of uniformly sized particles is required to acquire LV data in a reasonable time span. Tunnel water is supplied from the tap. However, it has been found that the majority of test runs have amazingly little particulate matter.

IV FACILITY OPERATIONAL REQUIREMENTS FOR ARTIFICIAL SEEDING

Compatibility considerations must be assessed early in programs for selection of seeding techniques and materials for wind tunnel operation. Those aspects, generally common to all facilities, include toxicity and the carcinogenic nature of the seed, both in short duration exposures, and cumulative effects both in the test area and atmospheric effluents. A similar evaluation should be made of the solvents required to remove films within the test area and circuit. Oftentimes, the solvents pose a more difficult problem coupled with volatility, possible flammability, and the confined work space in cleaning the tunnel.

Chemical properties of the seed and solvents, and their activity with the metals, paints, and seals of the flow ducting, drive systems, and optical, electronic, and mechanical instrumentation, must be considered.

In the cases of blowdown, high temperature and/or high pressure flows, and closed tunnels with relatively high exit temperatures from compressors, the seed's thermal characteristics are vitally important. Thermal properties must be assessed not only in regard to the relatively low density of seed-air mixture, but under circumstances of accumulated pooling or accidental excesses in seeding throughout the flow circuit of the facility. Oversight of these factors could easily lead to ignition or explosion.

With increasing use of LVs in tunnels, the seeding process is a consequential concern. For example, in the TGF, oil cleanout must be conducted after each test series. This process requires two days of down time. In the case of silicone oil, the safest solvent appears to be Freon 11, with a boiling point of 70° F. Hatches must be open and fans used for diluting the concentration of fumes. Reference is made to the tunnel of Figure 1. A large accumulation of oil occurs at the turning vanes immediately downstream of the diffuser. The other major deposit occurs at the 4.5' X 4.5' transition area at the axial compressor outlet. This, of course, is due to the compression and centrifuging process acting on the aerosol. Other

areas of the internal circuit are coated with lesser amounts of film. The oil also attacks paint in the circuit, causing flaking. Cleaning of the tunnel is, at best, a compromise. Film problems continue on the schlieren windows and the force balances. Seeding is accomplished in this tunnel with the dryer isolated from the test leg. However, even with this procedure, some oil is bound to contaminate the desiccant.

As has been experienced with the FDL tunnels being discussed here, seeding in each tunnel must be individually assessed and optimized for all the factors.

V SEEDING MATERIAL

The ideal seed material not only performs well in the seed generator and the test section flow, but also satisfies all the requirements of the previous section. Every investigator finds a livable compromise, usually unique with a given wind tunnel and the aerodynamic test objectives. FDL's experiences with seed material selections follow.

Solid Particles

Solid particle seeding at FDL is currently limited to use in the 6" prototype water tunnel and the Vertical Wind Tunnel. Tests have shown that 1 μm diameter alpha alumina particles are optimum for producing excellent clean signals. Experiences to date with a fluidized bed of graphite particles operating at 2800 psi have been unsuccessful because of agglomeration (Reference 4). However, additional effort will be made in this area.

Water-Glycerine

Liquid particles are the backbone of the FDL seeding accomplishments to date. A variety of water-glycerine mixtures have been tested and used for LV measurements in the Trisonic Gasdynamic Facility, Vertical Wind Tunnel, and 9" Self-Adaptive Wall Wind Tunnel. Their use has been generally suspended because of rust and other forms of induced corrosion experienced in the facilities and instrumentation under heavy use of this seed. Figure 7 indicates corrosion damage to the model support mechanism and strain gage balance after a one-week test.

Silicone Oils

This class oil was first investigated to produce seed in the Mach 6 HRNF which operates at P_0 s to 2,000 psi and T_0 of 1150^o R. Silicone oils

have been familiar to wind tunnel personnel for years as vacuum pump and manometer fluids with an apparently good record as to safety and health factors. The fluid first tried for this application was Dow Corning 704 which has an open cup flash point of 430° F and an auto ignition point of approximately 850° F. This seeding fluid was subsequently replaced by Dow Corning 200 which has a higher flash point, 600° F, and an auto ignition point of 850° F. The 200 oil is only 25% the cost of 704.

Thermally Safe Halogen Fluids

In search of extending liquid seeding techniques to high temperature high speed flows, a class of phosphate ester fire-resistant hydraulic fluids was examined. Although the auto ignition temperatures ranged to 1300° F, factors such as low flash points, high vapor pressures, and relatively high levels of toxic decomposition products were discouraging.

The halogen compounds are derived from common organic compounds where all the carbon-bonded hydrogen atoms are replaced by fluorine atoms. The resulting hydrogen-free compound is colorless, odorless, has low toxicity, and is essentially thermally inert. It is used extensively for vapor phase soldering. The compound chosen for seeding tests is made by 3-M under the trade name Fluorinert. Of the various compounds in this class, the FC-70 was selected because it is a liquid at room temperature and has a low vapor pressure. This fluid has been used successfully to seed the Mach 6 HRNF with the high pressure seeder. Results were as good as the silicone oil without the fire hazards. These fluids exhibit extremely minute degrees of dissociation (parts per billion) under very high temperatures, as experienced in high temperature tunnel applications. Because the 2 to 3 cc per minute of seeding fluid is vastly diluted and is exhausted to the atmosphere, there appears to be no problem. However, the toxic issue was thoroughly examined. The two toxic products produced are hydrogen fluoride and Perfluoro Iso Butylene (PFIB). OSHA standards for hydrogen fluoride are a maximum of 3 parts/million. Standards for PFIB exist only in eastern

countries, which set a level of 10 parts/billion. These values correlate with United States standard toxic lab tests on animals, substantiating that the PFIB is by far the most lethal. Toxic laboratory tests at elevated temperature and pressures are limited because there are no driving market factors for this type of application. However, at 420^o F and atmospheric pressure, PFIB is generated at 1 microgram/Gm-Hr. Further lab tests in this direction are needed for proven positive assurance that these fluids can be used on a continuing basis with no concern.

VI SEED GENERATION

Several methods of seed generation have been tailored, based on tunnel operating parameters and requirements necessary for accurate laser velocimetry data. Since design considerations generally restrict velocimetry measurements to the backscatter mode, ideal seed generation is restricted to 0.5 to 2 μm size range. Several types of seed generators have been used to meet these requirements.

Liquid Particles

Two Stage Atomizer (Figure 8) - This seeder is designed for relatively low back pressures and a 50-90 psi inlet air pressure. The first stage consists of a small liquid reservoir orifice aspirator to produce liquid droplets. Airflow of the aspirator carries these droplets to the second stage, which is a swirl separator. Dwell time and the washing action of the swirl result in a very high percentage of submicron-size droplets exiting from the system. The atomizer currently in use at FDL is a DISA type 55L17.

Sonic Spray Nozzle (Figure 9) - As with the two-stage atomizer, this nozzle is a low back pressure system with inlet pressures in the 20-60 psi range. The principle of operation involves an annular ring orifice injecting air into a resonator cavity. A second orifice tube is centered in the sonic resonator feeding liquid under pressure. This second orifice is set in harmonic resonance causing the liquid to be broken into small droplets. Tuning is accomplished by adjusting the air and liquid flows. When properly tuned, the droplets produced are mostly in the 0.5-2.5 μm range, and exit the nozzle in an ovoid plume. Particle size and population can be varied somewhat by selecting fluids with different physical properties, i.e. surface tension, density, and viscosity. A Sonimist Model 600S is currently being used at FDL.

High Pressure Seeder (Figure 10) - Typical blow-down tunnel P_0 s in the range of 500 to 3,000 psi create a need for seed injector systems capable of delivery at these high back pressures. In-house design of such a system created a versatile seed generator capable of producing liquid droplets 0.5 to 5 μm in size with delivery pressures from 300 to 3,000 psig. Seed population is controlled by the air-liquid throttling ratio. Droplets are first produced by shear action in the air-liquid mixing tee. The aerosol is further atomized in the tunnel stagnation areas as it passes through thin slots in the injectors (Figure 9). This high pressure particle generator has been developed with safety features to allow use of fluids which are thermally safe to use in the highly diluted aerosols in the tunnel flow, but which might ignite if allowed to accumulate in liquid or high aerosol concentrations. Backup shutoff valves, check valves, and a purging system are designed into the unit. The purging is accomplished while the tunnel is in full flow. System controls and operating procedures have been established to further improve safety.

Solid Particles

Commercially available 1 μm alpha alumina has been used successfully in the Water Tunnel Facility by manually adding small quantities (2 to 3 cc) to the water reservoir every fifth run during the fill operation, which disperses it uniformly. Some seed dropout occurs in the flow straightening filter. This is removed by occasional back flushing. This seed material is also used in the Vertical Wind Tunnel Facility. Injection is accomplished via a motorized salt shaker arrangement at the bottom of the tunnel.

VII PARTICLE SIZING

The seeders previously described had been pushed into service to obtain LV data of critical research programs to compare with, and validate, findings from other measurement techniques. Particle sizes and densities were independently assessed in comparison to the natural seed, visually, from observing scattering within a laser beam, and from control of the processor in relation to generated velocity histograms. As the complexity of the flows being measured increased, it became essential to better characterize the seed being generated, as well as to assess the effectiveness in the generator controls and choice of fluids in improving the fluid conversion efficiency, particle densities, and population of the desirable particle sizes.

Instrumentation

The instrumentation used for determining the particle size distribution of the various nozzles and injection probe is manufactured by Particle Measuring Systems, Inc. (PMS) of Boulder, Colorado.

The instrumentation consists of PMS model CSASP-100, a classical scattering aerosol spectrometer probe, and the companion data handling unit, the Particle Data System, PMS Model PDS 200. The aerosol sample is drawn into the instrument via a small blower. These units are compact and of very rugged design, as they are designed for on-site testing rather than laboratory applications. The instrument is a classical scattering spectrometer using the principle that resultant scattered light by a particle is a direct function of its size. A particle passing through a laser beam produces a pulse of scattered energy that is read by two detectors coupled to pulse height analyzers. One detector sees all scattered energy striking the collection lens, while the second detector is centrally blocked, thus collecting only from diffuse sources outside the area of primary scattering. By manipulating the gain ratios of these two collection systems, a very small sample volume, centered in the laser beam, can be observed, thus resolving particles at high concentration accurately.

The system has the capability of allowing the operator to choose among four particle diameter size ranges. Each range is subdivided into fifteen intervals or bins. The size ranges and intervals are:

Number	Size Range	Interval (Bin Width)
0	2.0-20.0 μm	1.2 μm
1	1.0-12.25 μm	0.75 μm
2	0.5-2.75 μm	0.15 μm
3	0.320-0.755 μm	0.027 μm

Each interval or bin has the capacity of 9,999 counts. The presence of the 10,000th count presents an overload situation.

If desired, the instrument can be operated in an automatic scanning mode. This allows the stepping from one size range to another in sequence. This stepping is determined by either a time factor, chosen by the operator, or automatically, when an overload situation may occur. To insure a common time base between ranges, a sampling period is chosen which is short enough to prevent an overload situation occurring on the most populous interval.

The automatic scanning method was utilized for this test allowing the detection and counting of particles with diameters ranging from 0.320 μm to 20.0 μm . A real-time CRT histogram display of particle size distribution is provided as an integral part of the PMS Model PDS 200.

Testing Procedure

The testing procedure involved the temporary setup of the seeding systems which operated at atmospheric pressure in an open area. The input to the PMS CSASP-100 was positioned in the central area of seed plumes. The collector horn (accelerator) was positioned with its long axis approximately 100° to 110° from the central plume axis. See Figure 11 for test setup. This insured correct and representative sampling of the plume.

Five seeding techniques were tested in this investigation: a sonic spray nozzle, a high-pressure seeder of in-house design, in combination with and without two injection tube configurations, and a dual chamber swirl-atomizer manufactured by DISA electronics.

Seed material used included: Dow Corning 200 diffusion pump oil in three viscosities, 200, 50, and 10 centistoke (cs), and two glycerine-water mixtures, one at a 20% glycerine concentration, and one at a 50% concentration.

The seed/seeder combinations and order of testing were as follows:

- a. Sonic Spray Nozzle (Sonimist)
 1. 20% glycerine - 80% water.
 2. Dow Corning 200 fluid - 200 cs.
 3. Dow Corning 200 fluid - 50 cs.
 4. Dow Corning 200 fluid - 10 cs.
- b. High Pressure Seeder with Mach 3 Injection Tube.
 1. Dow Corning 200 fluid - 10cs.
 2. Dow Corning 200 fluid - 50 cs.
 3. Dow Corning 200 fluid - 200 cs.
- c. High Pressure Seeder - no injection tube.
 1. Dow Corning 200 fluid - 200 cs.

- d. Two Stage Atomizer (DISA)
 - 1. Dow Corning 200 fluid - 10 cs.
 - 2. Dow Corning 200 fluid - 50 cs.
 - 3. Dow Corning 200 fluid - 200 cs.
 - 4. 50% glyc - 50% water.
 - 5. 20% glyc - 80% water.

- e. High Pressure Seeder with Mach 6 Injection Tube.
 - 1. Dow Corning 200 fluid - 10 cs.
 - 2. Dow Corning 200 fluid - 50 cs.
 - 3. Dow Corning 200 fluid - 200 cs.

Data Reduction - Plotting Procedure

A series of tests was performed with the PMS Model PDS 200 in the automatic scanning mode. This mode of operation allows the collection of data by automatically stepping through the four ranges. This is done on a common time base. If an overload condition occurs, i.e. a count greater than 9,999 in any bin, the PDS 200 automatically steps to the next range in sequence. This is an unacceptable situation, as it is imperative that the data from all four ranges be taken to a common time base. If this condition occurred, appropriate adjustments were made and the test was repeated.

A series of at least three runs in each range was made. Each range is subdivided into fifteen size increments. The mean value for all three runs for each range/bin was calculated. The mean value (particle count) was then normalized by dividing the mean count of each bin by the ratio of bin widths from range to range in order to produce meaningful multirange plots.

A further manipulation was done to facilitate the plotting procedure. The maximum count over all four ranges for a particular test was adjusted to equal 100 per second. The remaining counts in each bin were adjusted accordingly. The constant K shown on the ordinate of the data plots represents the magnitude of this normalization. The actual particles per second through the sampling volume can be determined on each plot by dividing by the constant K. As the intent of the exercise was to determine the particle size trends being generated by the various seed/seeder combinations, these manipulations allowed the data reduction to proceed more efficiently with an acceptable result.

The accumulated data was then plotted on log-log graph paper. As per the above discussion, the maximum bin count over the four ranges is adjusted to 100 per second. This value is plotted on the ordinate, while the mean value of each size interval is plotted on the abscissa. As an overlapping condition exists between the four ranges, discrepancies in apparent concentrations measured in the overlapping regions occur. The question of which count values are more correct arises. One must recall that background noise influences all pulse height analyzers operating on real data. As the signal to noise ratio (SNR) for pulses of high amplitude is greater than for those of low amplitude, it follows that the SNR is greater for sizes with high channel numbers. Therefore, in the case of overlapping ranges, the best fit is found by choosing the data from the high channel numbers as opposed to the low resolution data from the adjacent size range. This was done in the process of developing the plots. This eliminated the occurrence of a double count (particles of same diameter counted in two overlapping ranges).

Results

The results must be viewed with the application of the seeding techniques in mind. The purpose of the seeder is to provide light scattering centers for applying laser velocimeters to experimental aerodynamic research. Obviously, the larger the scattering center, the greater the

signal amplitude produced. The size limitation is dictated by inability of the larger particles to follow the intricate flow patterns present in high velocity flows. It is generally felt that for normal flow fields, a particle diameter of 2 to 2.5 μm is the maximum acceptable. Therefore, generation of submicron sized particles would seem to be desirable. A complication arises when the limitations of the laser velocimeter optics are considered. The majority of LV research applications are conducted with a backscatter optical configuration. This configuration, while mechanically efficient, is very inefficient optically, compared to a forward scattered system.

While LV system signal to noise ratios and other wind tunnel LV instrumentation constraints vary considerably, it might generally be stated that the average backscatter LV has a very difficult time "seeing" particles very much smaller than 1 μm . Therefore, for the backscatter mode, a useful range of particle diameters appears to be ($2.1 \mu\text{m} \geq X \geq 0.8 \mu\text{m}$).

As will be seen from data presented, the seeding techniques tested all do an excellent job of generating particle sizes below the upper limit. An examination of the data also shows that a large quantity of particles below 0.8 μm is present. This trend is common to all the seed/seeder configurations. The apparent presence of the large amount of submicron particles was a source of concern to the authors. After much reviewing of the data, the data collection techniques, the test parameters, and several consultations with personnel who operate this particle sizing instrumentation on a daily basis, a consensus was reached that the data is correct.

A series of 16 graphs are shown in Figures 12 through 27 depicting particle count vs particle size data for the various seed/seeder combinations. The following comments and observations are made.

Sonic Nozzle - In the case of the sonic nozzle, the 10 cs oil produced the highest particle density in the useful range, while the water-glycerine and 50 and 200 cs oils performed uniformly in the 0.5 to 1.2 μm range.

High Pressure Seeder - The Mach 6 injector, with its smaller total slot area, out-performed all the seeders in producing the most seed in the 0.3 to 1.2 μm range. Its best performance was with 10 cs oil. While the Mach 3 injector, with its large total slot area, fell somewhat in performance in relation to the Mach 6 injector, it is interesting to note that its operation was significantly better with 200 cs oil than with oil of 50 or 10 cs.

A set of runs was made with the high pressure seeder without the injectors. This is shown in Figure 22. The purpose was to investigate the additional atomizing contributions made by the injectors. Both injectors improve the particle density, generally in the 0.6 to 1.07 μm range, in some cases by a factor of 2.

Two Stage Atomizer - All the test data from this seeder support the fact that this device has a sharp cutoff at somewhat over 1 μm particle size. It performs best with water-glycerine. The unusual peaking at 1 μm for the 50 and 10 cs oil is left unexplained.

Aerosol Velocity in Plumes - Opportunity presented itself to map the velocities of the aerosols in the plumes of the seeders operating at ambient conditions. Figure 28 indicates a similarity of all seeders tested. This information would be of value, together with the air velocities in the plenum chambers of the various facilities, to estimate the shape and turbulence of the seed pattern in the test section, depending on the orientation of the seed plume.

VIII DISPERSION AND DATA RATES

In order to facilitate velocimetry mapping in the vicinity of wind tunnel models, relatively large areas of a test section must be uniformly seeded, or movable stream tubes employed to provide adequate data rates. Closed loop, continuous running tunnels, and blow-down tunnels, each presents its own specific problems. Short run times of the latter require a high population to provide sufficient data for turbulence measurements, whereas closed loop systems can be more casual.

2' Trisonic Gasdynamic Facility (TGF)

Initial evaluation of candidate seed systems for this facility was made with a single-component LV optical system that was constructed in-house. Tunnel construction provided an opportunity to correlate forwardscatter and backscatter data. Figures 29 and 30 illustrate the optical configuration used. It should be noted that these tests were performed without a model in the tunnel for seed performance evaluations only. Subsequent testing with aerodynamic models was performed using a TSI 3-component LV system based upon these results.

Three types of artificial seed generators were used in this facility. A manifold network consisting of 15 outlets across the lower half of the stagnation section was supplied by two of the two-stage atomizers using water-glycerine mix. Although this system gave good results in the forwardscatter mode, it was abandoned because the small particles generated (below 1 μ m) were not visible in the backscatter mode. This was, in part, attributed to a very low S/N ratio created by bubbles in the laminated window on the backscatter side of the tunnel. This window has since been replaced with a solid window of higher quality. The sonic nozzle and high pressure seeders previously described were also installed and tested in the stagnation section. Placement of these systems just downstream of the last screen is pictured in Figure 31.

The sonic nozzle was tested in several positions within the stilling chamber. Resultant positions, data, and findings concerning the seeding within the test section are shown in Figure 32. Measurement of the area seeded was derived from visual estimation using a laser light plane and backscatter scans using the single component LV system. Velocity-data rate scans were taken at Mach 0.6 and 2.3 as a function of seed flow rate, seed material, and viscosity. Representative scans are plotted in Figures 33-35. Note the higher data rate at Mach 2.3 in Figure 35 at the same flow rate. This is attributed to the resultant increase in number of particles per second traveling through the test volume with no significant change in the seed pattern dimensions. The nozzle positioned at the bottom of the stilling chamber permitted usable backscatter measurements within 1/8" of the test section floor. In Figure 36, comparison of data rates between forwardscatter and backscatter mode indicates greater than 50 times more sensitivity in the forwardscatter mode. Two factors contribute to this high ratio. Natural light scattering characteristics are weighted into the forward direction and the high population of submicron particles generated by the sonic nozzle, which are not seen in the backscatter receive mode. This ratio was significantly reduced when the high pressure seeder was used, because fewer submicron particles were generated.

The high pressure seeder was tested only in one position within the stilling chamber, but with different materials and flow rates at Mach 0.6 and 2.3. Representative scans are charted in Figures 37 and 38. As noted above, this injector produces a larger population of particles in the 2 to 6 μm range, and therefore a significantly higher data rate in backscatter mode.

Vertical Wind Tunnel (VWT)

Two particle seeding entries have been made into the Vertical Wind Tunnel (VWT), one utilized an in-house design backscatter LDV for examining the possibility of using a commercial smoke generator for seeding. The other entry used a DISA two-component, on-axis backscatter LDV. Seeding trials with this latter arrangement consisted of 1.0 μm alumina and various glycerine and water mixtures.

Test results using the smoke generator and mineral oil produced data rates ranging from 1488 cps to 944 cps with a mean of 1297 cps. Lower data rates were obtained when commercial "cloud oil" was used, replacing the aforementioned mineral oil. This may indicate a smaller particle size distribution with the "cloud oil", as opposed to the size distribution generated using mineral oil. Note that these data rates were obtained in an off-axis backscatter arrangement. The coverage of the smoke generator tended to increase as the tunnel ran, indicating a low seed dropout rate.

The same seeding arrangement, but with the DISA on-axis backscatter optics, did not yield the same results. The particles are too small for being detected by the long f1 (1800 mm) and high f-number of the DISA system. The high population density in the tunnel produced high background noise, giving a low SNR. This compounded the difficulty of "seeing" the small scatter centers presented by the smoke particles.

The ultrasonic spray nozzle was employed using a water-glycerine mixture. This technique resulted in marginally acceptable data rates. A seeded area of approximately two square feet was observed.

An attempt to apply the two-stage atomizer to the VWT was nonproductive due to the submicron particles produced and the low particle population. The seeded area was small in relation to the 12' diameter of the test section.

A solid particle seeder was fabricated which used 1.0 μm alumina particles. Difficulty was encountered in positioning the seeder correctly in relation to the test volume. The low particle count (15-20 cps), and small area of coverage, (approximately 8 ft^2), are indicative that more development is needed in this technique.

The large area of the test section, 113 square feet, and the distance of the seed generator to the test section, 29' to 65' depending on individual seeder requirement, present special problems. The long focal lengths and resultant slow collection optics are also a detriment to efficient LV operation. The need to provide seed of correct size and density to allow the LV to "map" large areas is recognized, and work will proceed in that direction.

9" Self-Adaptive Wall Transonic Wind Tunnel

As has been described earlier, natural seed in this blowdown tunnel had provided limited velocity data with an LTA. At later dates, a one-component fringe system and a three-component, three-color LV with a 5-watt laser were used to explore further one- and two-component velocity mapping. Two of the DISA two-stage atomizers were installed to feed the large volume, 6' diameter plenum. These seeders generate a high percentage of 1 μ m particles. Because their particle generating rates are relatively low, the plenum was flooded with this aerosol prior to running. The combination of this priming, continuous seeding during the short runs, and existence of natural particulates was adequate to acquire valuable one-component velocity information at data rates approaching 100 counts/sec. Data from these runs will not be presented in this report. However, the plenum priming technique used in these experiments could be useful when just "a little more" seed might be needed.

Mach-3 and Mach-6 HRNF

Because the high pressure seeder and LV measurements were immediately needed to conduct high speed boundary layer research, all shakedown was conducted simultaneously with the acquisition of aerodynamic data. Some of the seeding and LV work is presented in References 4 and 5. The seed injectors in both tunnels are located in the settling chambers immediately downstream of the last screen. Tests made with a variety of orientations of the aerosol from the injectors indicated that best data rates and mixing

uniformity occur with the injector aerosol flow facing downstream. It should be noted that in Figure 9 there are two configurations of the Mach-3 injector. The injector with the short length of slots was developed to assess the possibility of heavier local seeding of the lower tunnel wall. The relatively low Mach number, coupled with the unusual transition ramp from the circular stagnation region to the rectangular nozzle inlet, made this possibility worth examining. To date, there has been no opportunity to study and experiment with this attempt at local seeding in this relatively small Mach-3 flow. Problems with the seed injector in the Mach 3, experienced and documented in Reference 5, and hypothesized as icing, have been investigated and corrected. The seeding injector had been slightly bent at a low slot, thus opening it up substantially, and grossly upsetting the entire seeding process. Current use of a 15-watt laser on the 3-component, 3-color backscatter LV arrangement in one component operation, together with the high pressure seeders, has resulted in free stream data rates of over 1,000 per second in both tunnels. Particle densities and data rates in the boundary layer were sufficient to make quality measurements within .007 to .010 inches of the wall. Velocity repeatability at these points was excellent, and scatter in the profiles was minimal. The profiles matched both theory and other measurement techniques.

6" Prototype Water Tunnel

Ideal seed for this tunnel would be near the density of water and have a high index of refraction. As was briefly mentioned in the seeding section, 1 μm Alpha alumina particles best matched this requirement. Larger particles appeared to increase the noise level without substantive increases in signal level. The tests were conducted with bulk seeding of the stored water before the run.

Instrumentation

The electronic and signal processing package included a Macrodyne 2,000 series LDV processor, a Pacific photometric power supply for the PMT, a TSI frequency shifter model 9180, a Comlinear Corp CLC-100 amplifier, and Apple

computer utilizing floppy disk storage of data. The Macrodyne LDV processor is a counter-type with 2 ns resolution. The package includes a 2096-1 power supply, a front end detection module (FED 2096-2), and a logic and output display module (LOD 2096-3).

A TSI frequency shifter (number 9180) was added to the system with the shift against the tunnel flow. The frequency shift was found to be most effective at 20 KHz (.02 MHz). This shift allowed the effective use of the bandpass filters available in the Macrodyne processor. A Comlinear Corp CLC-100 amplifier was put in line between the PMT output and the frequency shifter control. The amplification of the signal at this point increases the SNR, which increases the effectiveness of the Macrodyne processor. The amplification was on the order of 10:1. The Apple computer was interfaced to the Macrodyne. The Apple accepts the digital output from the Macrodyne and stores the raw data on floppy disks for processing at a later time.

The layout of the LV optics for this water tunnel seeding test is shown in Figure 39. Optical specifications of this single-component LV include a Spectra Physics 164-08 Argon-Ion laser being used on the $.4765 \times 10^{-6}$ line at approximately 150 mW of power. The beam was collimated using a TSI 9108 collimator and was then turned at a right angle using a turning mirror. The beam then entered a TSI 9102-C Polar Rotator which adjusts the beam polarity for the best performance. The beam was then split to a 50 mm separation (each 25 mm from the optical axis). The beams then entered the Bragg cell, also a TSI item, TSI 9182-T.

The Bragg cell allows the shifting of the frequency of one of the beams relative to the other. This allows measurement of the low-velocity flow found in the water tunnel. The beams then pass through a TSI beam steering module, which allows the precise beam crossing alignment. This was TSI model 9175. The two beams (one shifted, one unshifted) then pass through two holes drilled through a front surface plane mirror. The mirror was oriented at a 45° L to the optical axis in the vertical plane and is approximately 6" X 6". The beams then pass through the focussing/collection lens. This lens is actually a telescope objective with a 30" fl and a 6"

aperture (f5). This lens was used as both an input/focussing lens and as the primary collection lens. The collected light was collimated, turned at a right angle to the input optic axis by the 6" X 6" mirror, and refocussed on the photo multiplier tube (PMT) by a similar lens. The PMT had a 400 μ m pinhole in place.

Tests and Results

With a limited reservoir capacity and reliance on seeding, considerable coordination and close timing must be achieved to acquire approximately 350 data points per measurement position per run. A run averages out at one minute duration. This is partially due to startup time to establish quality flow, and the limited time available before velocity changes occur with head loss. Nonetheless, valuable experience was gained. Figure 40 is an example of data acquired with an empty test section. It illustrates the measurement performance of the LV-seed combination and flow quality of the tunnel, which uses a foam flow straightener. It also demonstrates that the LV system is capable of taking data within 3/16" of the inner wall of the tunnel, which is 1/4" plexiglas.

IX CONCLUSIONS

The developments described in this paper have provided reasonable LV test capabilities in a number of facility types. The tests and evaluations have quantified a number of important parameters and introduced new possibilities, which could lead to more effective seed generation, use, and control.

As long as the laser velocimeter continues to measure only point velocities, there is a drive to further reduce the cross-sectional area of seeding streamtubes in the test sections to reduce contamination, particularly in closed tunnels. The results in the Vertical Wind Tunnel indicate that high density streamtube seeding is essential in large wind tunnels. In the case of water tunnels, continuous flows and high particle density streamtube seeding are essential for acquiring masses of LV data. The 2' Water Tunnel currently being built at FDL will incorporate these features.

The in-house developed high pressure seeder has versatile capability to seed many flows. Further gains can be achieved via injector improvements. High temperature fluids have been demonstrated in seeding modestly hot flows of the Mach 6 HRNF. These and others will be examined for use in Mach 10 to 14 flows with T_0 to 2600° R.

The particle sizing test results provided valuable information on the optical diameter of the particles, and the performance of the seed and seed generators. Additional sizing measurements with multiple angle scattering equipment, aerodynamic particle sizing techniques, and in-situ approaches would aid in further understanding of particle characteristics. This could lead to highly selective particle size generation to match LV performance. In general, it appears that each new tunnel entry for LV analysis becomes a research project in itself. Factors to be considered include tunnel operating temperatures, pressures and volume, compatibility, contamination tolerances, and placement of seed injectors for maximum efficiency. Access to the model test section often becomes troublesome because of the physical

size of LV optical systems. Ideally, forwardscatter techniques would yield the highest accuracy measurements and rapid data acquisition, and the least tunnel contamination, because smaller amounts of artificial seed could be used. Physical constraints and logistics problems in coupling a transmit and receive optics might be overcome with innovative approaches.

X THRUSTS AND CONTINUING PROGRAMS

The analysis of natural and artificial aerosol generation at FDL, as well as at other organizations, clearly illustrates that, in many cases, a large number of submicron particles exist in the flows. These particles of .05 to .50 μm are capable of adequately populating the most interesting of complex flows, as well as faithfully representing the velocity components in LV measurements. However, it appears that the most direct answer to mapping these complex flows is to extend LV technologies and explore new approaches to make substantive improvements in optical signal to noise ratio, and detection sensitivity and selectivity.

In the meantime, advances in controlling particle size and streamtube distributions from a seeder, in improving data processing and management, and in improving theoretical treatment of particle lag, will all certainly extend use of the larger particle in analyzing complex and mixed flows.

There appears to be payoff for filtering inlet air to the stagnation section of a tunnel. This would selectively eliminate particulates smaller than those detectable by the LV system. Signal to noise ratio should be substantially improved.

The agglomeration problem associated with solid particle seeding without liquid carriers must be attached or circumvented for use at very high pressures. Innovative scientific approaches must be utilized to develop controlled size and high density solid particle fields, perhaps via thermochemistry, electrostatic and electromagnetic processes, ultrasonics etc. This is particularly needed for very high stagnation temperature flows where fluid seeding may be, at best, of limited choice and with marginal safety and/or environmental concerns.

The LV seeding operation must be more tunnel "user friendly." Low-pressure drop particulate filters should be developed and installed downstream of test sections of continuous tunnels. This would substantially reduce resources and frequency of tunnel clean-ups and exposure to health

problems. It would provide flexibility of test scheduling to allow sensitive instrumentation, such as hot wires, to successfully operate immediately following LV tests with minimum clean-up time.

XI REFERENCES

1. Cline, V.A., "Application of the Laser Velocimeter in the AFFDL Trisomic Gasdynamic Facility," ASD Reserve Report 76-108-B5, April 1978.
2. Trolinger, J.D., Smart, H.E., Cline, V.A., "Feasibility of Utilizing Laser Doppler Velocimeter Techniques in Very Clean Wind Tunnels," AFFDL-TR-79-3084, August 1979.
3. Mayo, W.T., Smart, A.E., Hermes, R.J., Trolinger, J.D., "Flow Velocity and Angularity Measurements in the FDL Trisomic Gasdynamic Facility and Self-Adaptive Wall Wind Tunnels with a Laser Transit Anemometer," AFWAL-TR-81-3081, August 1981.
4. O'Heren, C.H., Parobek, D.M., Weissman, C.B., "Laser Velocimeter Developments for Surveying Thin Boundary Layers in a Mach 6 High Reynolds Number Flow," AFWAL-TR-83-3111, February 1983.
5. Weissman, C.B., "Laser Velocimeter Developments for Boundary Layer Measurements in Supersonic and Hypersonic Flows", AFWAL-TM-83-193-FIMN, September 1983.

XII ACKNOWLEDGEMENTS

The authors wish to acknowledge contributions made to this technical effort and report by personnel of the Experimental Engineering Branch.

They are grateful to Mr. Charles H. O'Heren for software development for processing the particle sizing information, as well as data from the special velocimeter systems used to evaluate the seed dispersion, data rates, and correlating velocities.

Thanks go to TSgt Kenny C. Miller, who developed the technical graphics, and to Mss Rita L. Kibler and Ann T. Mosconi, for word processing.

PERFORMANCE RANGE

P_0 - 200 TO 4,000 PSF

MN - .05 TO 3.0

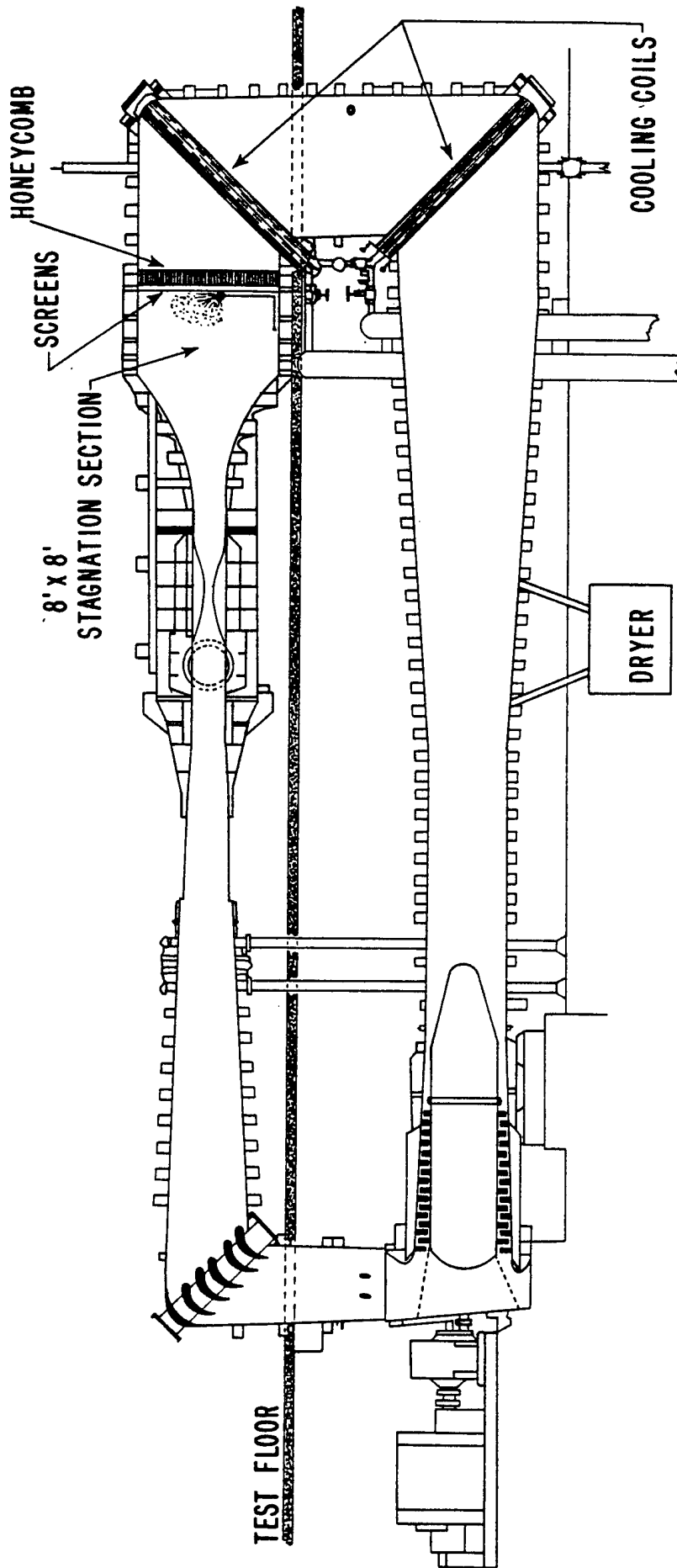

Figure 1 Two-Foot Trisonic Gasdynamic Facility

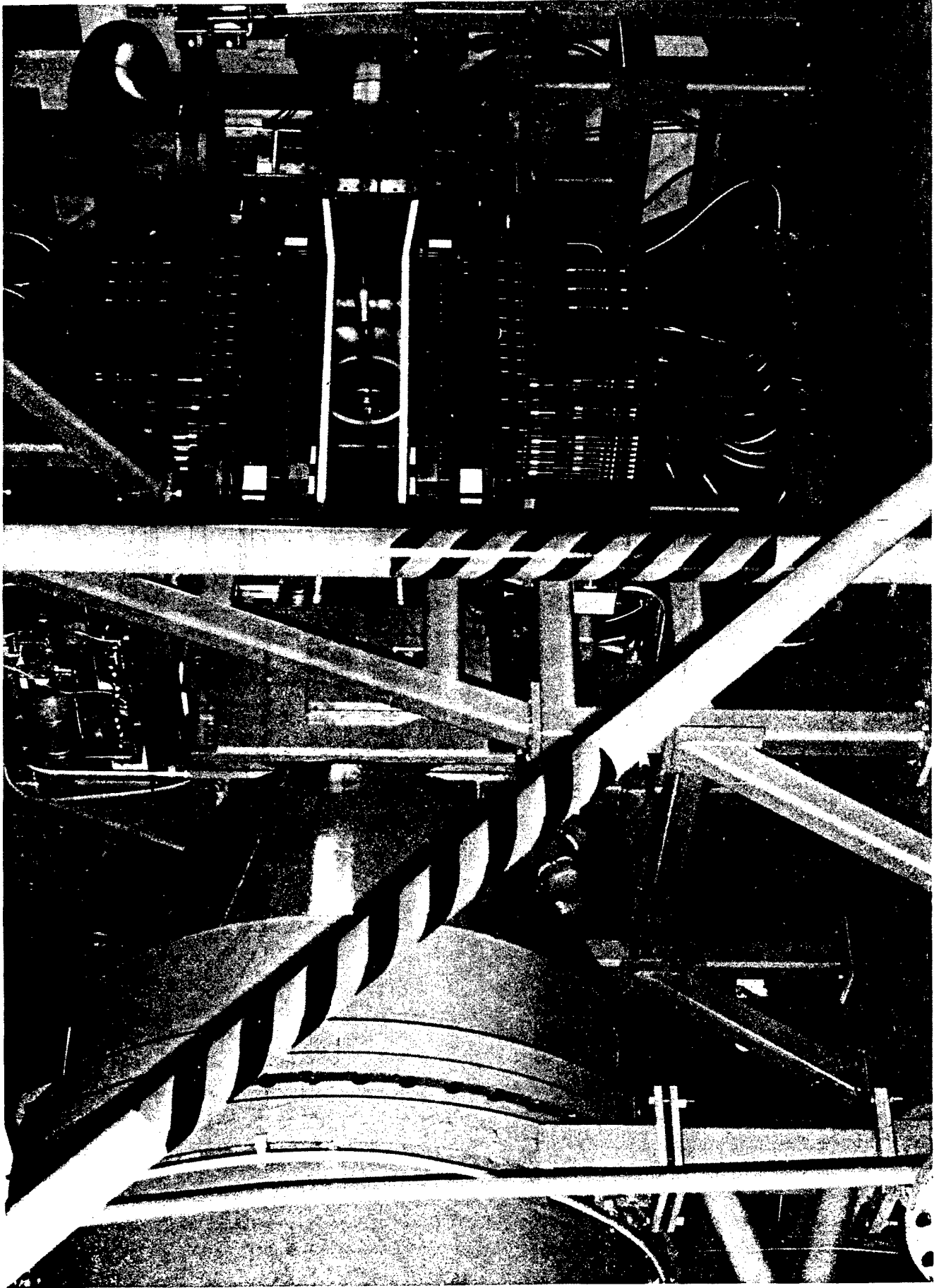
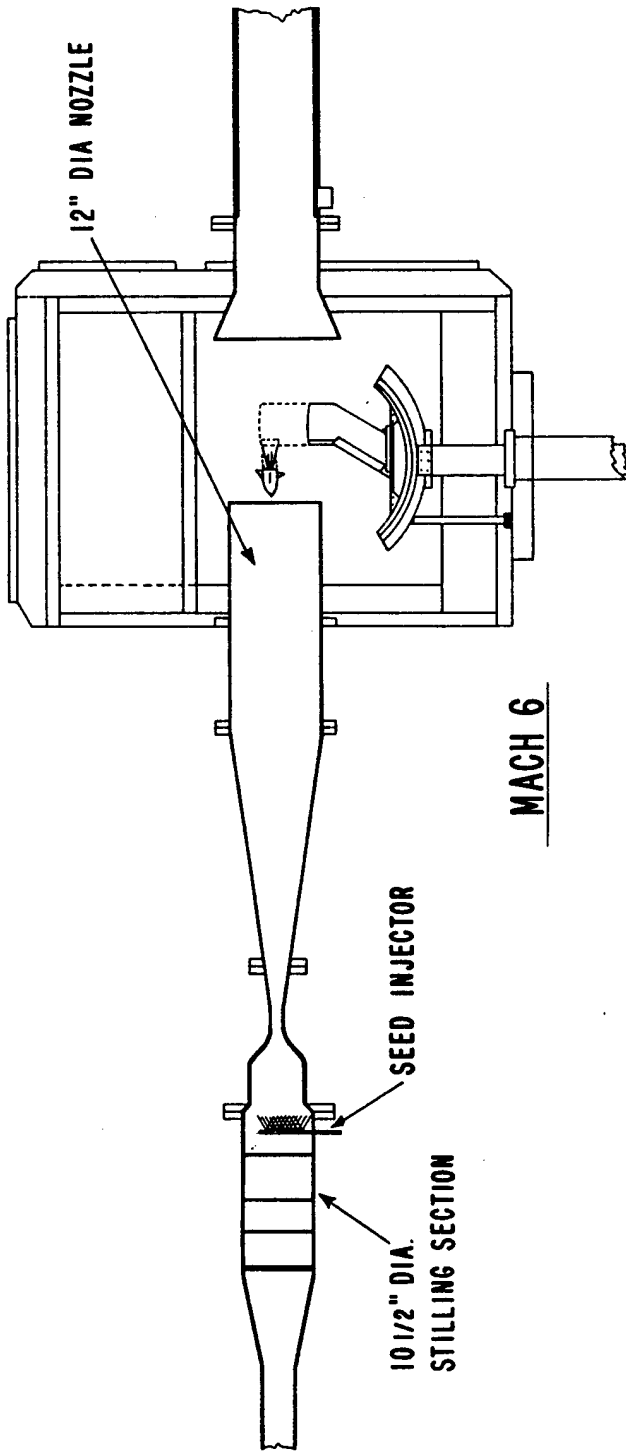

Figure 2 9" Self Adaptive Wall Transonic Wind Tunnel

PERFORMANCE RANGE

$P_0 \sim 700 - 2100 \text{ psi}$

$T_0 \text{ MAX} \sim 1150 \text{ }^\circ\text{R}$



MACH 6

PERFORMANCE RANGE

$P_0 \sim 85 - 560 \text{ psi}$

$T_0 \sim \text{AMBIENT}$

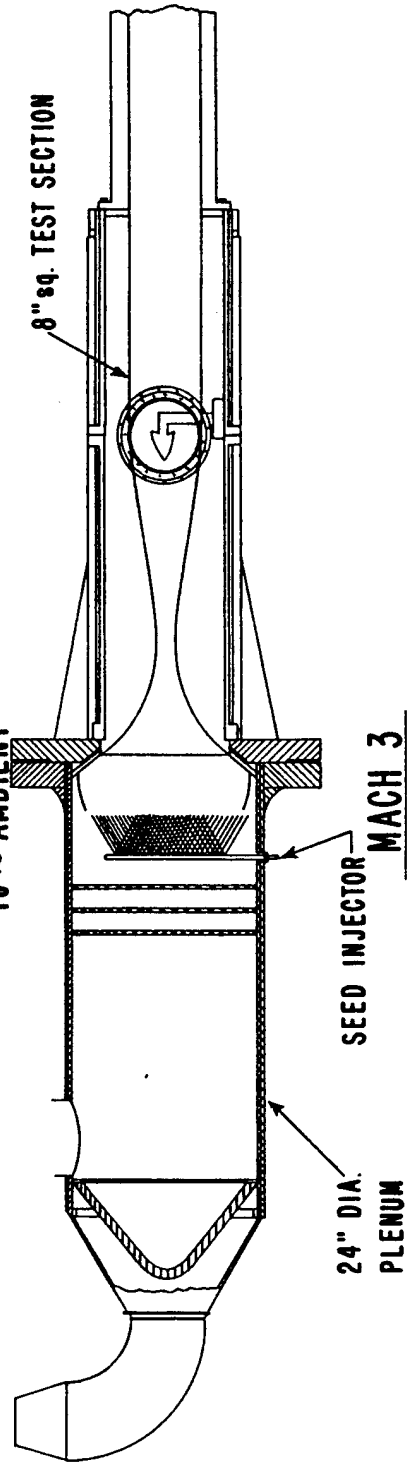

MACH 3

Figure 3 High Reynolds Number Facilities

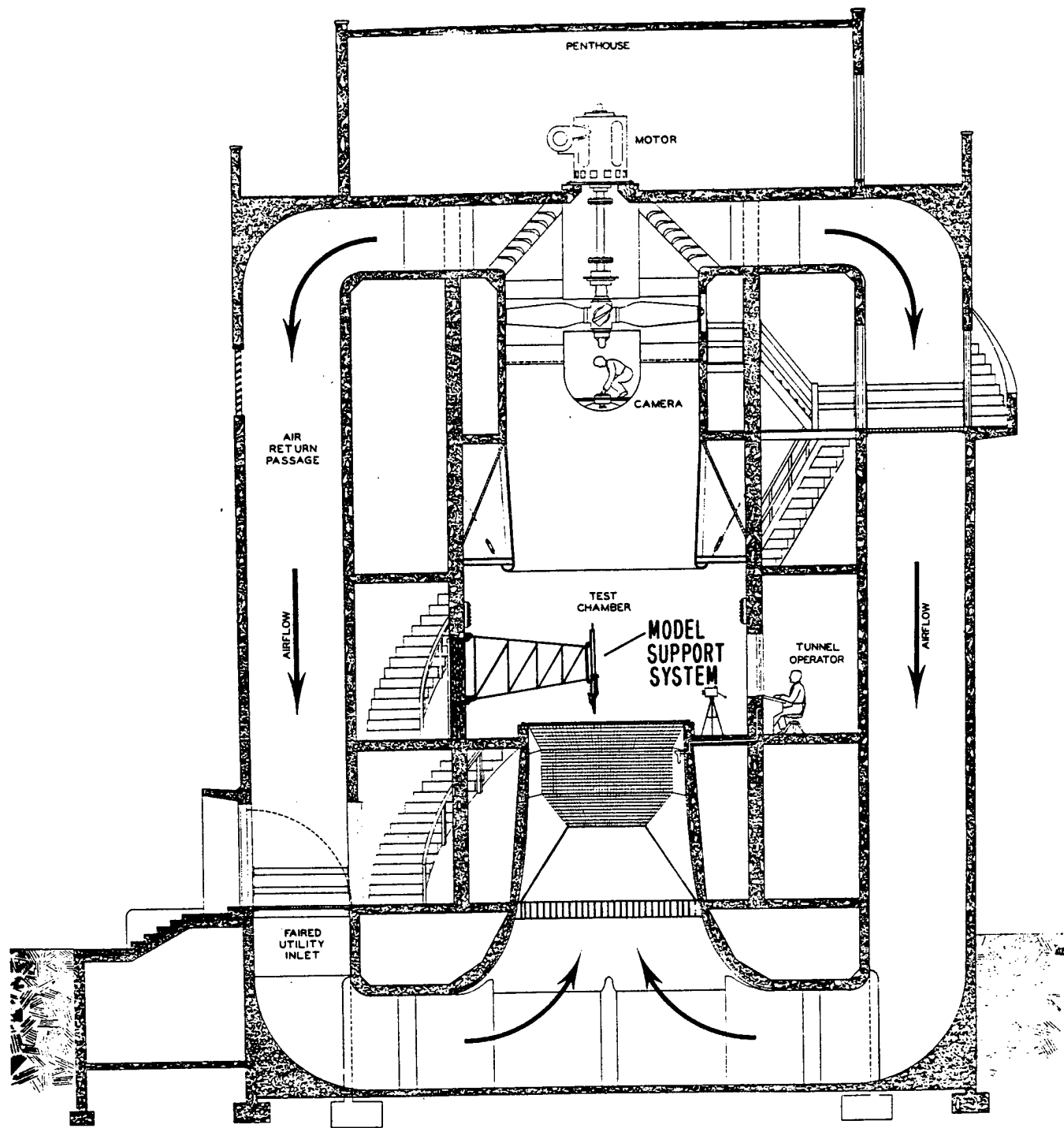

Figure 4 Vertical Wind Tunnel

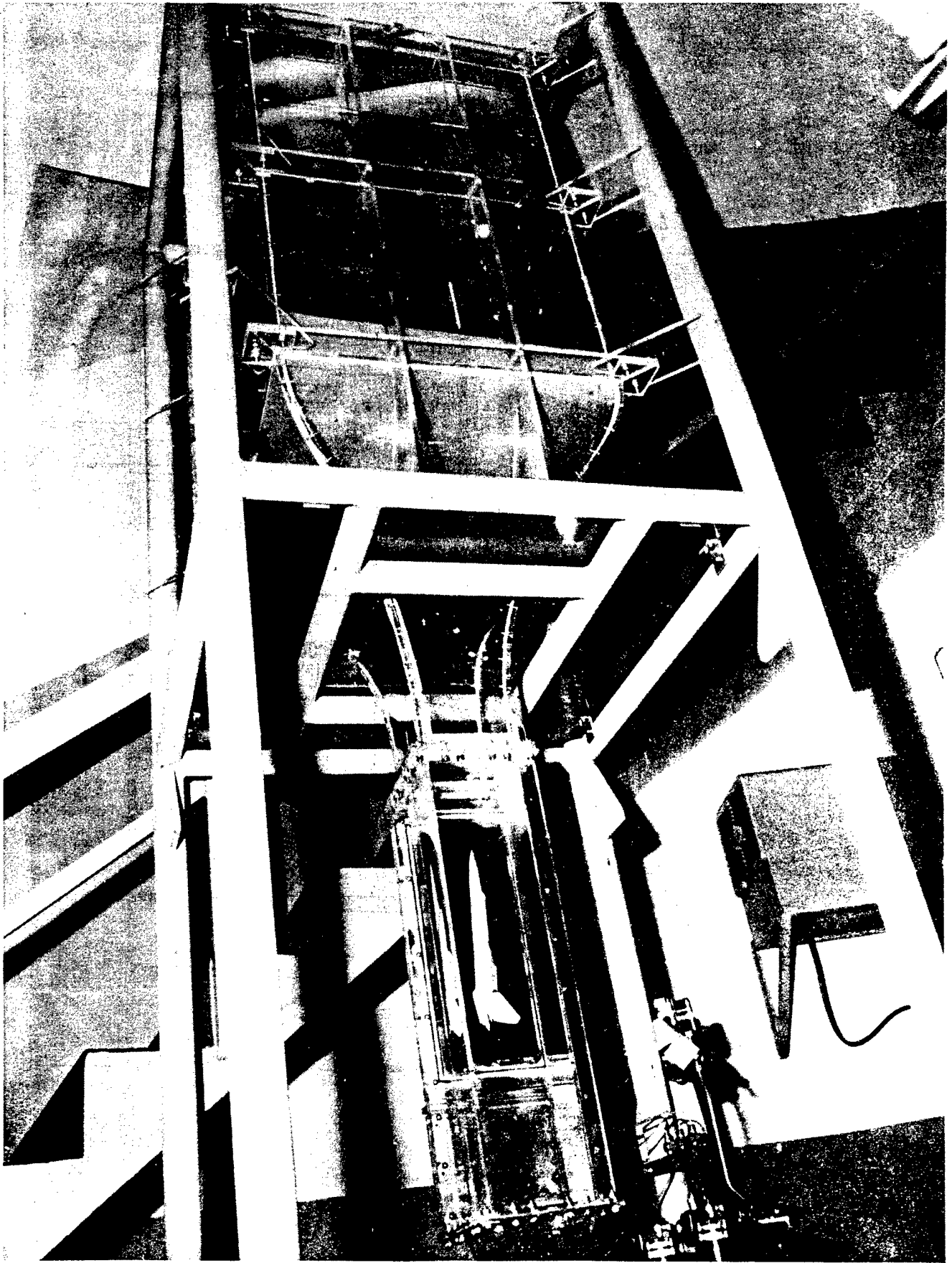

Figure 5 6" Prototype Water Tunnel

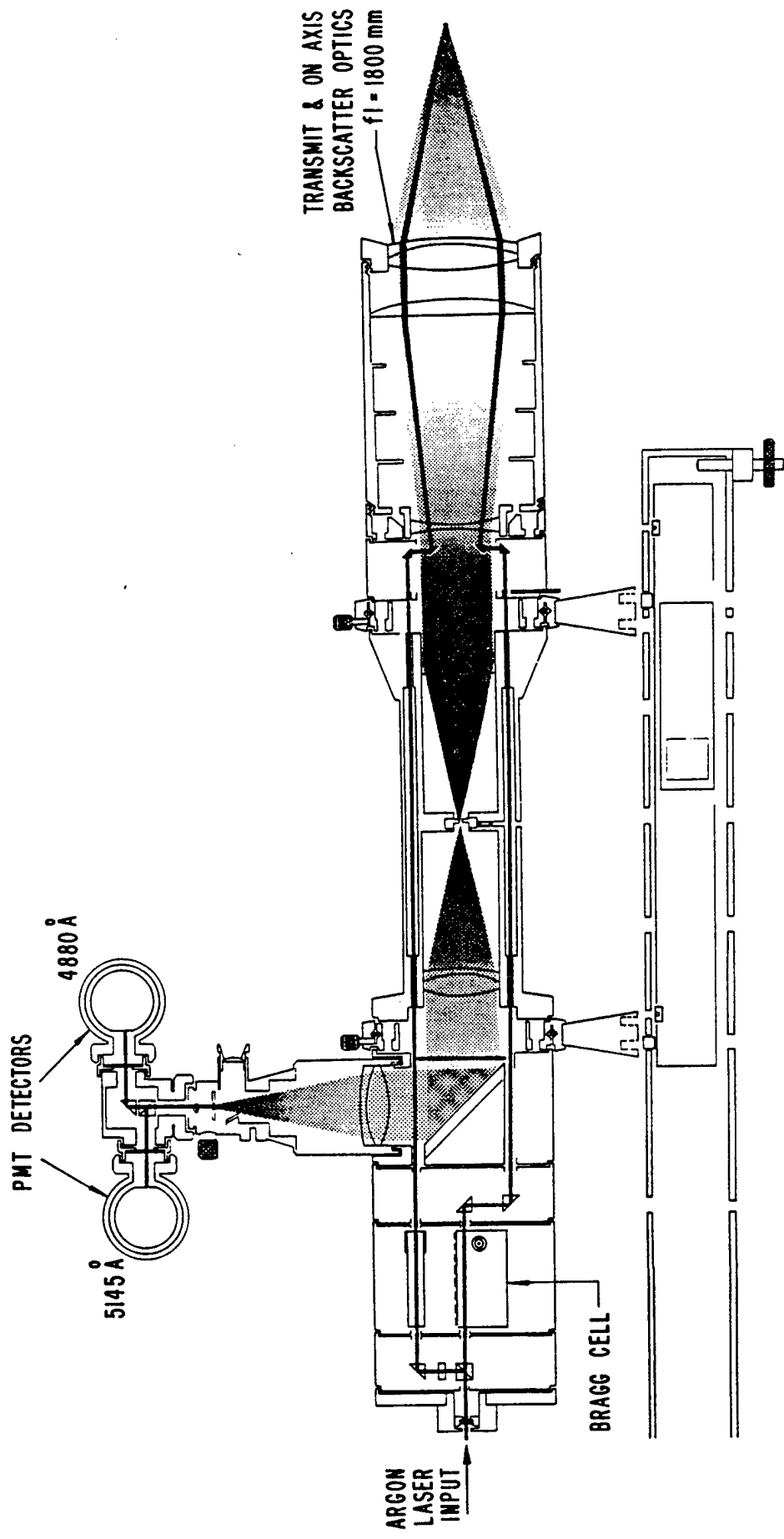
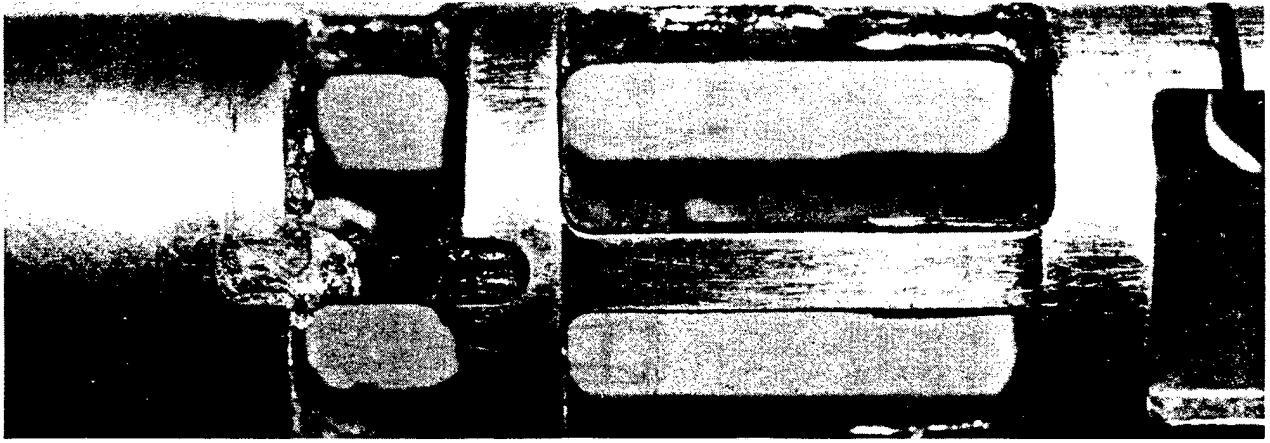
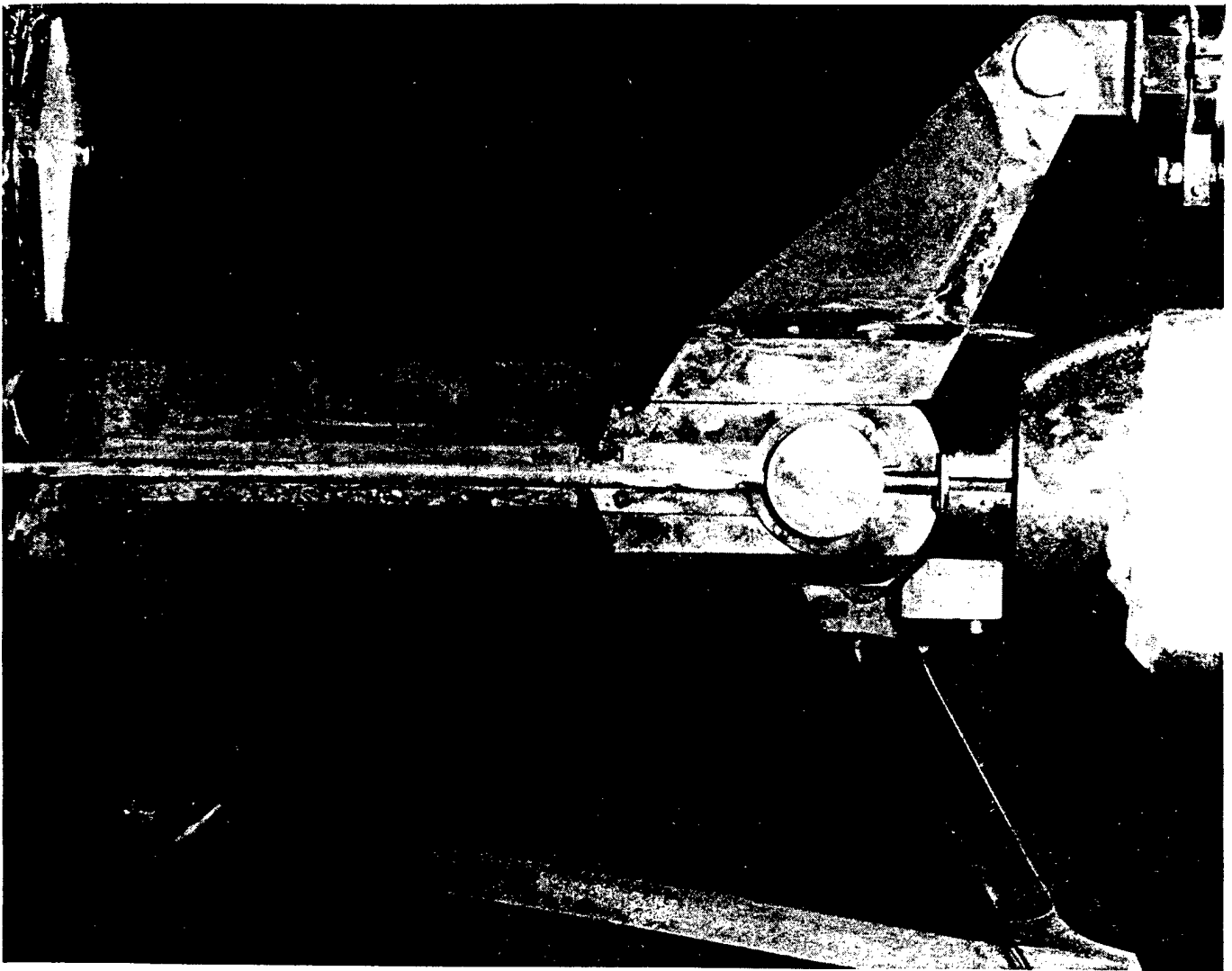

Figure 6 Disa I.V System for Vertical Wind Tunnel



STRAIN GAGE BALANCE



VWT MODEL SUPPORT SYSTEM

Figure 7 Corrosion in VWT from Water-Glycerine Seed

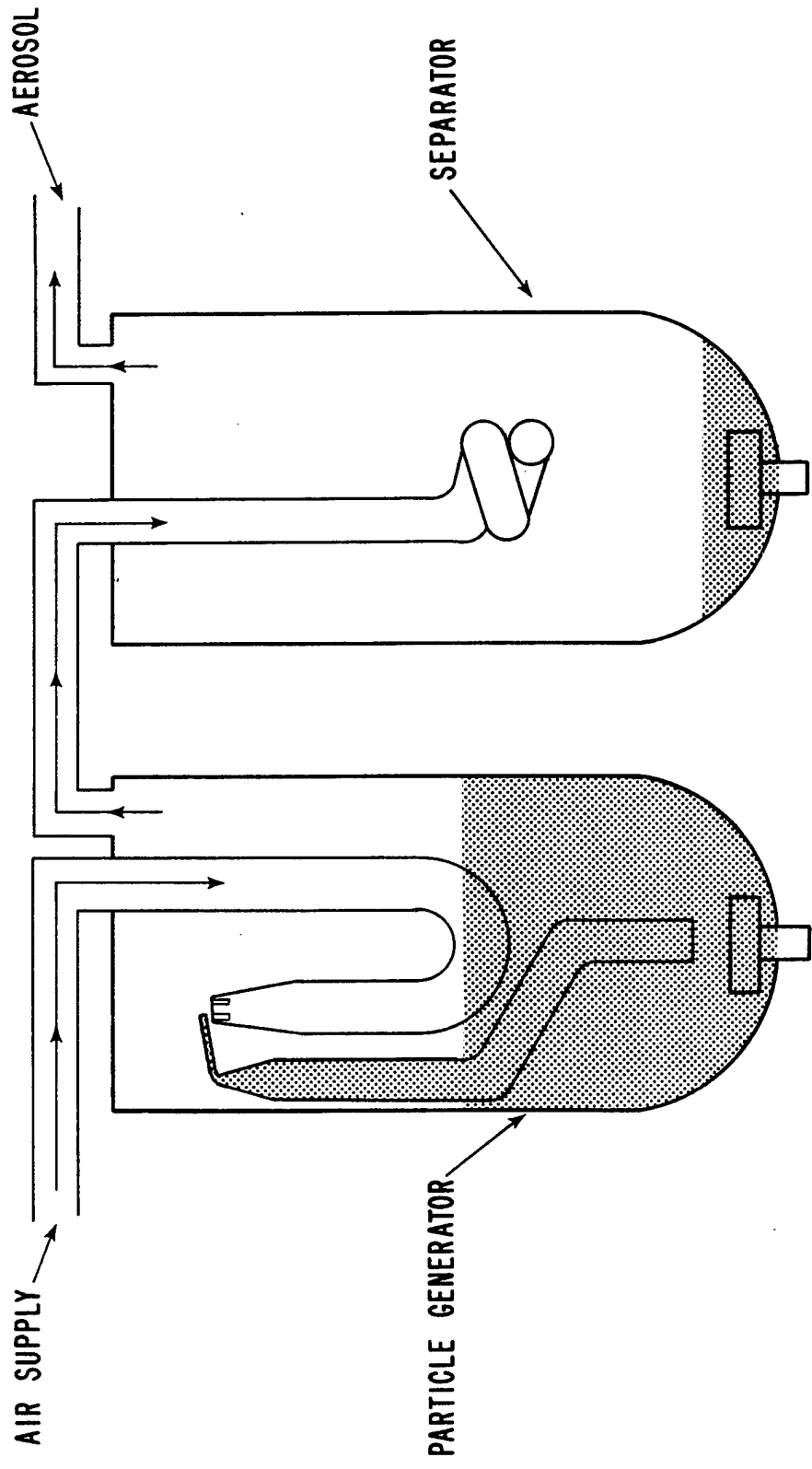

Figure 8 Two Stage Atomizer

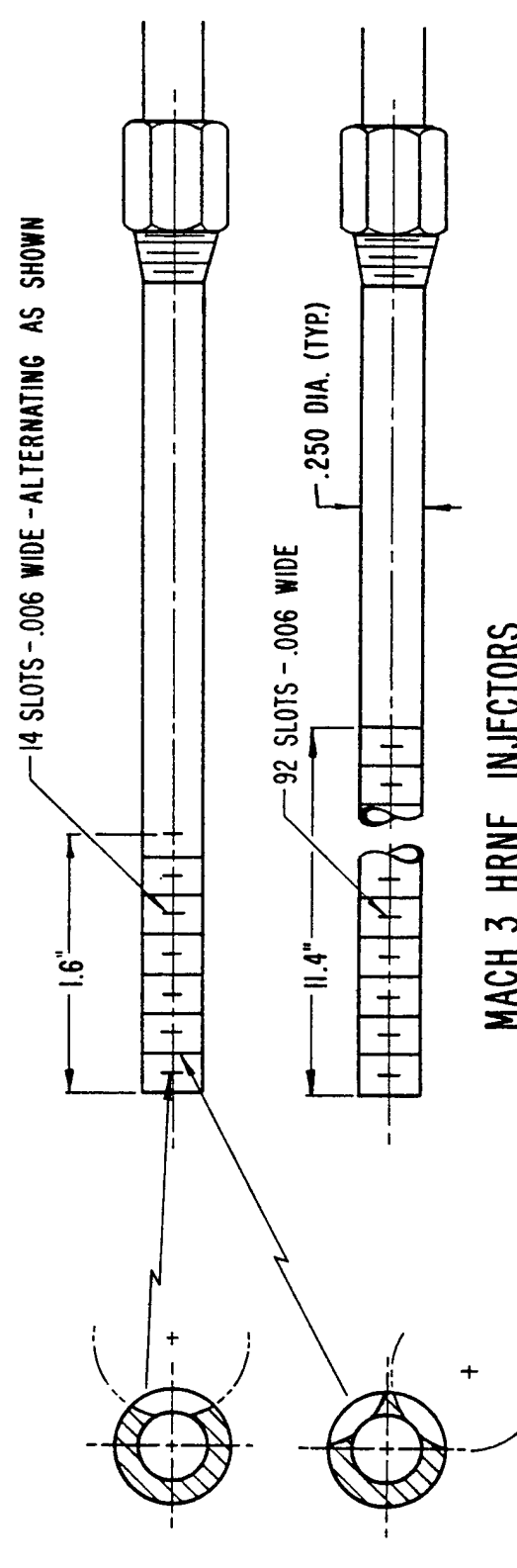
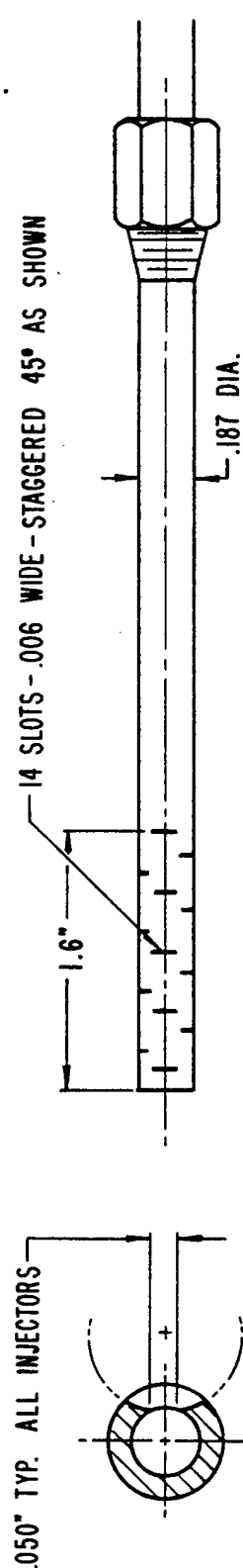
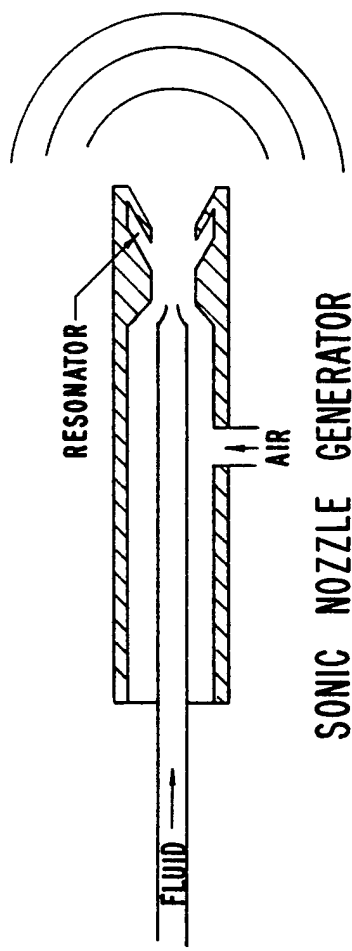
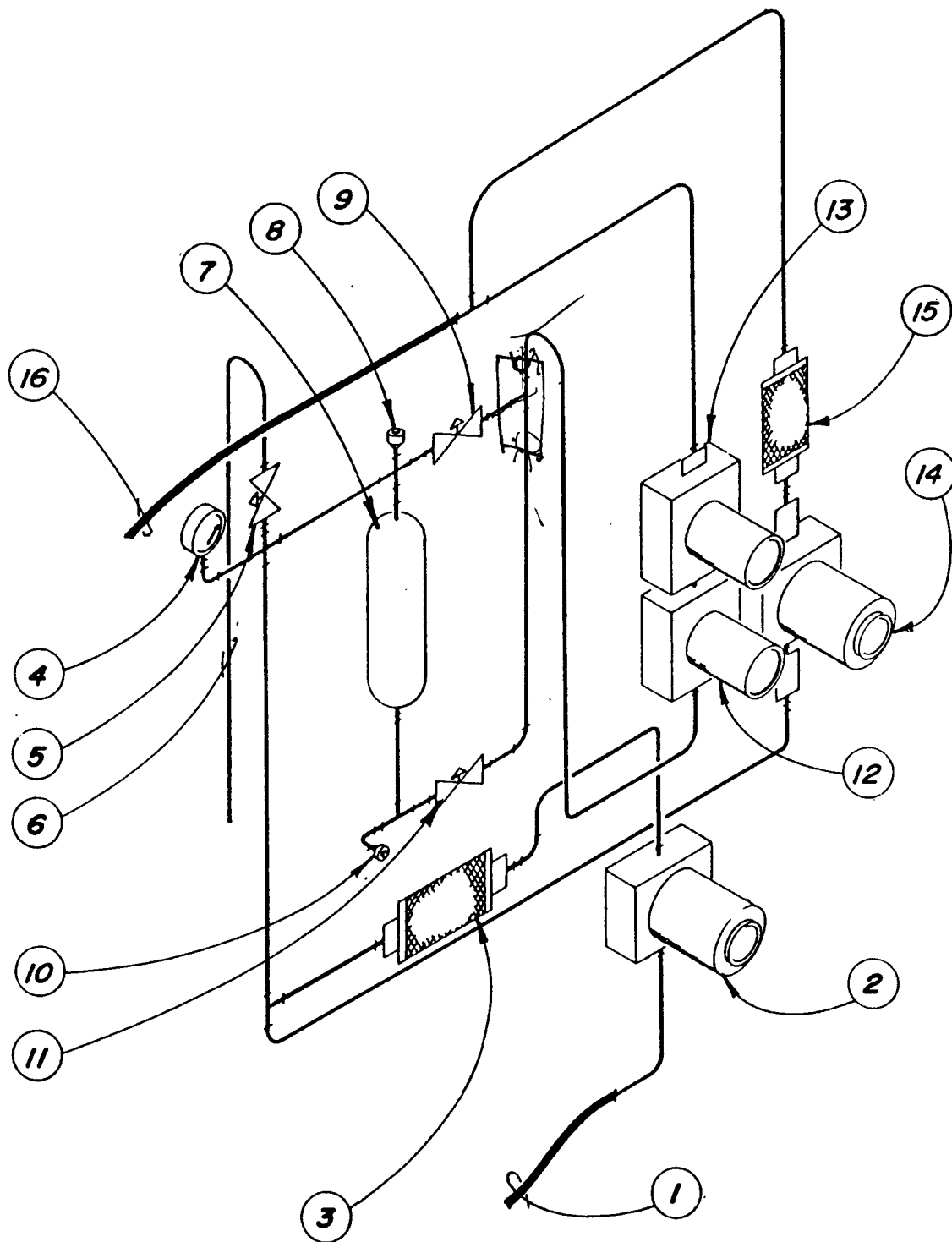

Figure 9 Sonic Nozzle and High Pressure Injectors



- 1 AIR INLET LINE
- 2 AIR INLET SOLENOID VALVE
- 3 CHECK VALVE
- 4 PRESSURE GAUGE
- 5 MANUAL BLEED VALVE
- 6 MANUAL BLEED LINE

- 7 SEED RESERVOIR
- 8 FILLER CAP
- 9 AIR METERING NEEDLE VALVE
- 10 DRAIN PLUG
- 11 SEED METERING NEEDLE VALVE
- 12 SEED SHUTOFF SOLENOID VALVE

- 13 BACKUP SEED SHUTOFF SOLENOID VALVE
- 14 PURGE LINE SOLENOID VALVE
- 15 CHECK VALVE
- 16 SEED MIXTURE OUTLET LINE

Figure 10 High Pressure Seeder

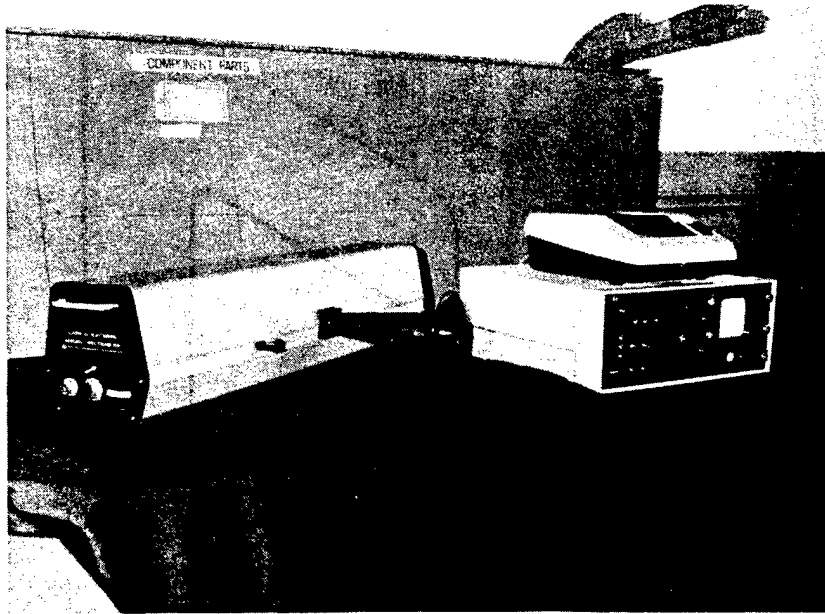

PMS PARTICLE SIZER



HIGH PRESSURE SEEDER

Figure 11 Particle Sizing Test Setup

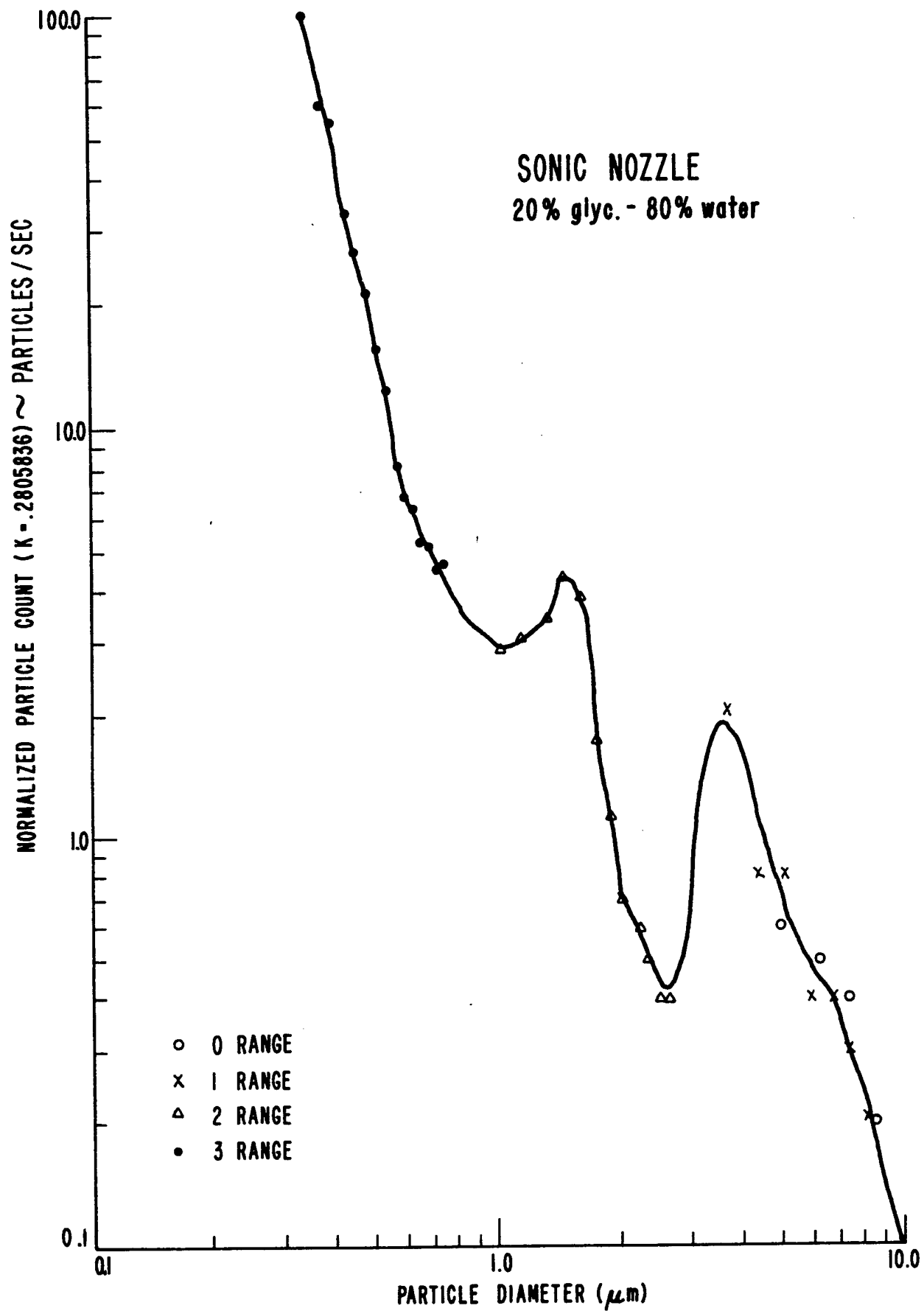

Figure 12 Sonic Nozzle Particle Sizing

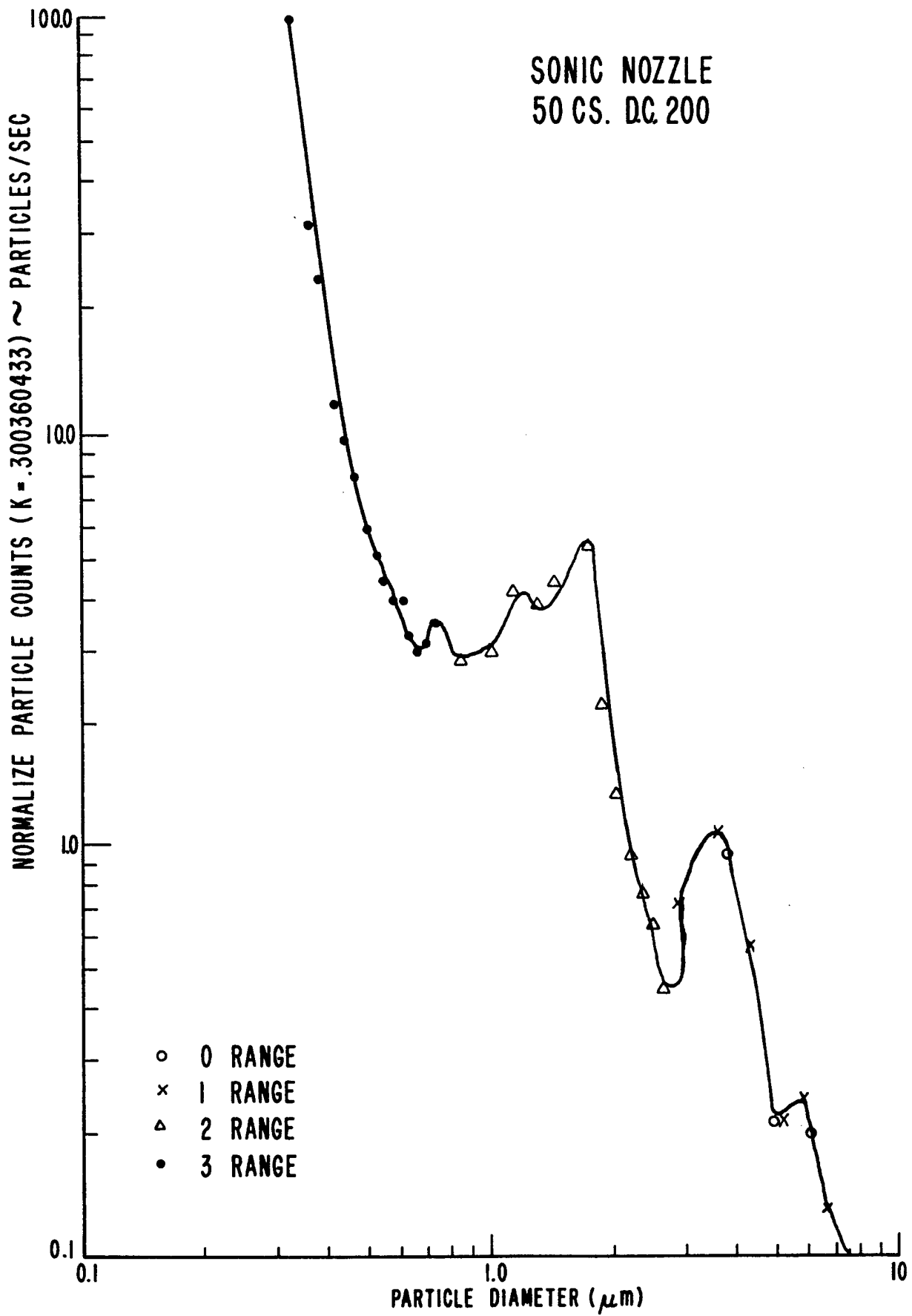

Figure 13 Sonic Nozzle Particle Sizing

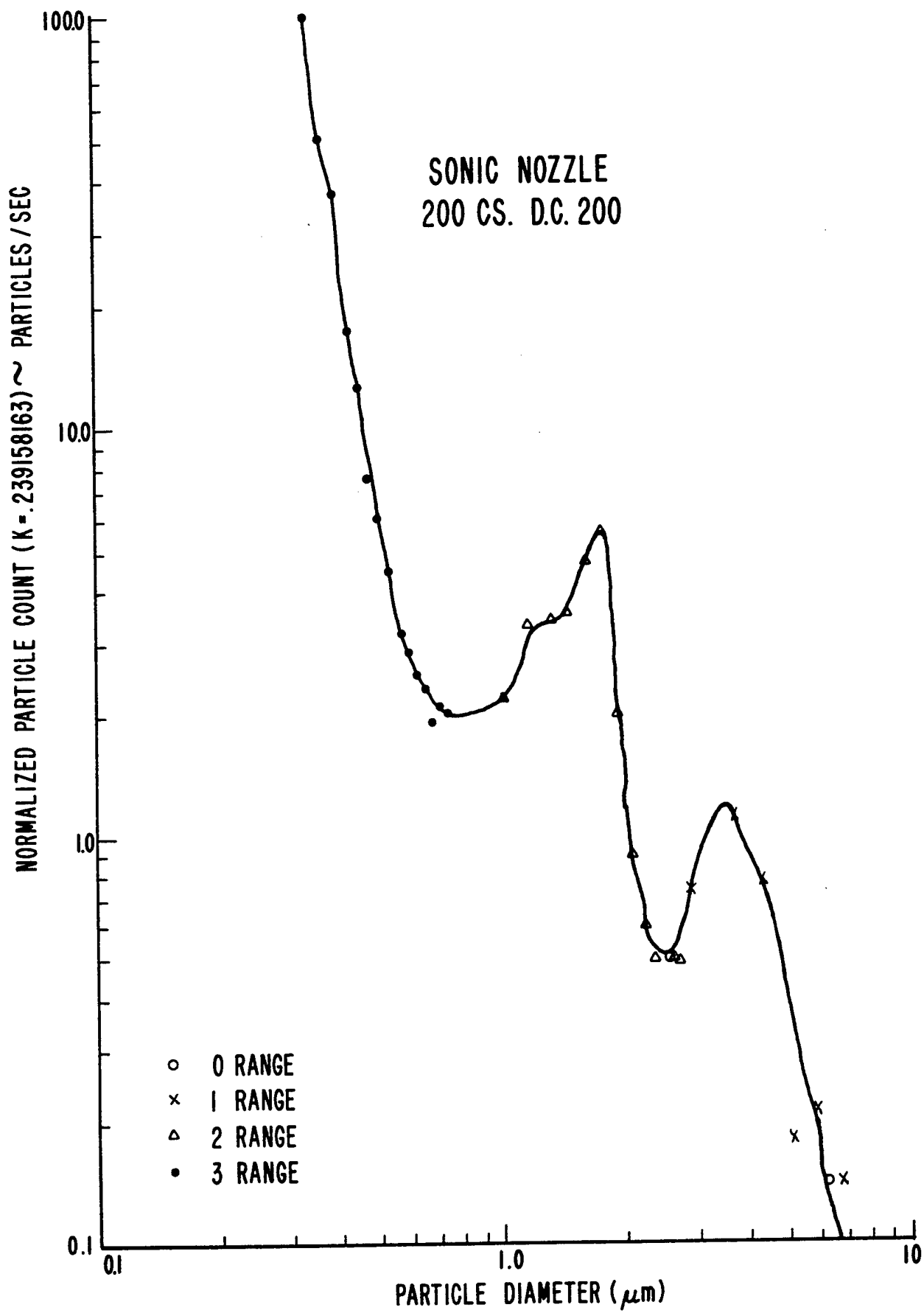

Figure 14 Sonic Nozzle Particle Sizing

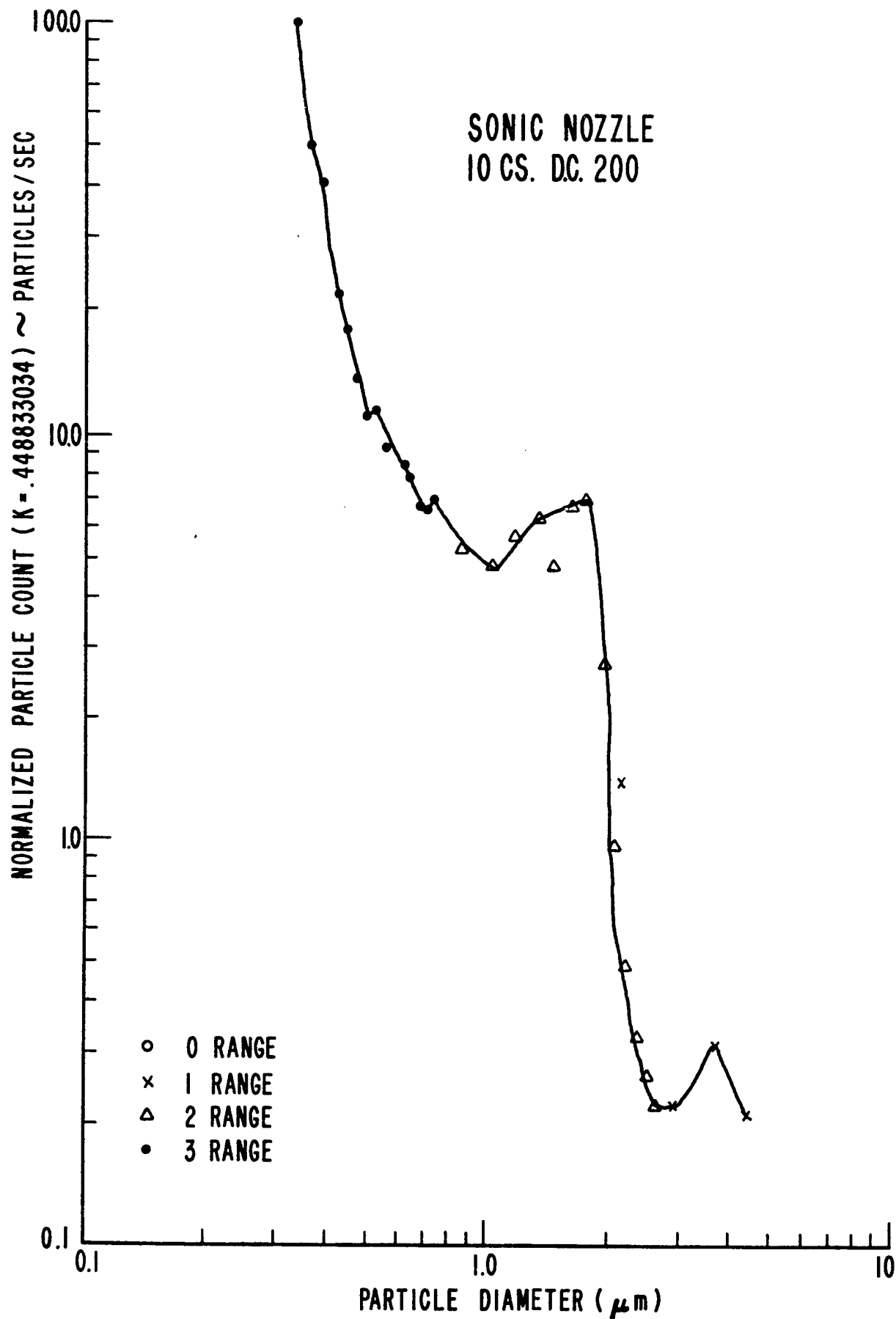

Figure 15 Sonic Nozzle Particle Sizing

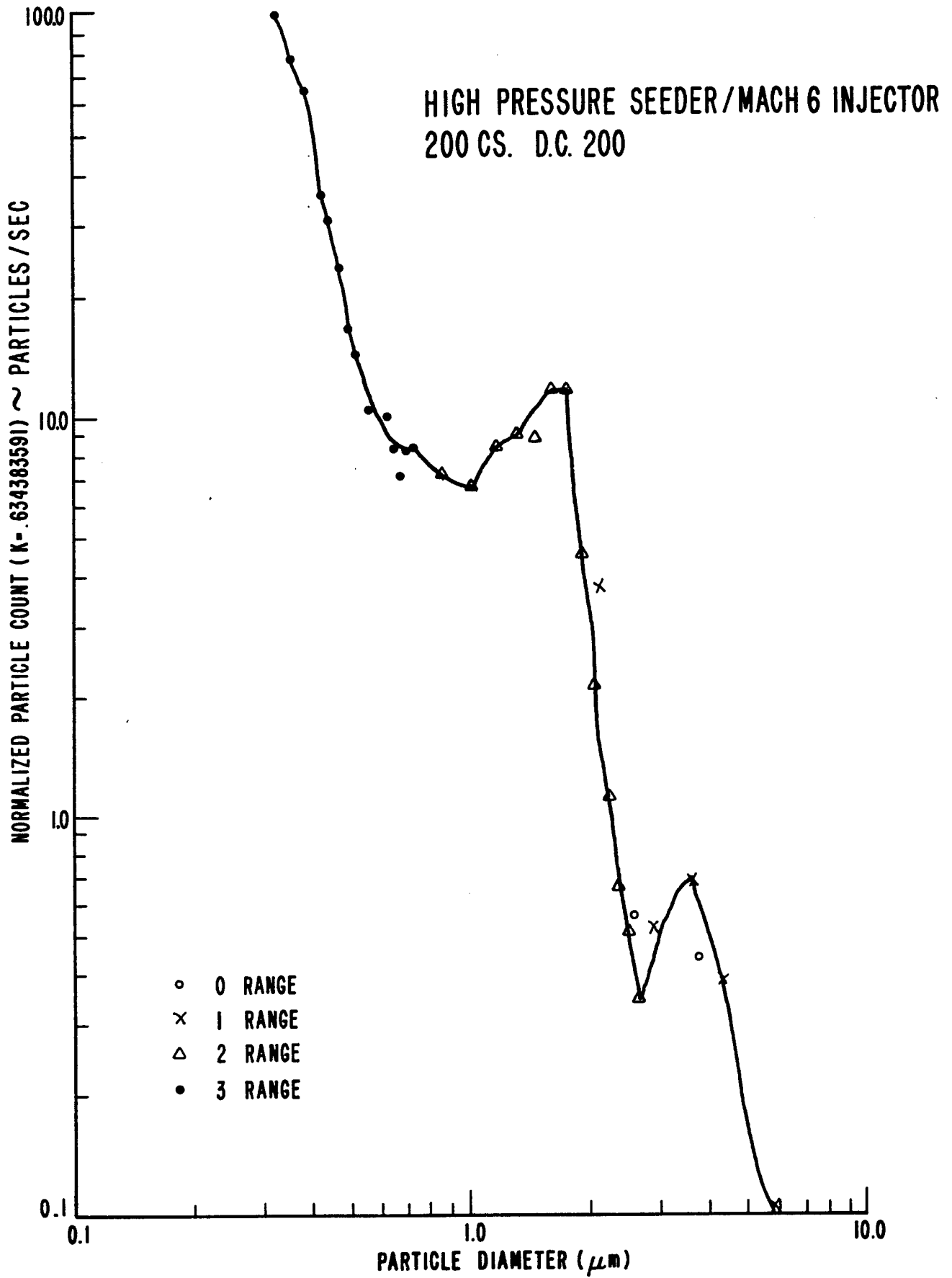

Figure 16 Mach 6 High Pressure Seeder Particle Sizing

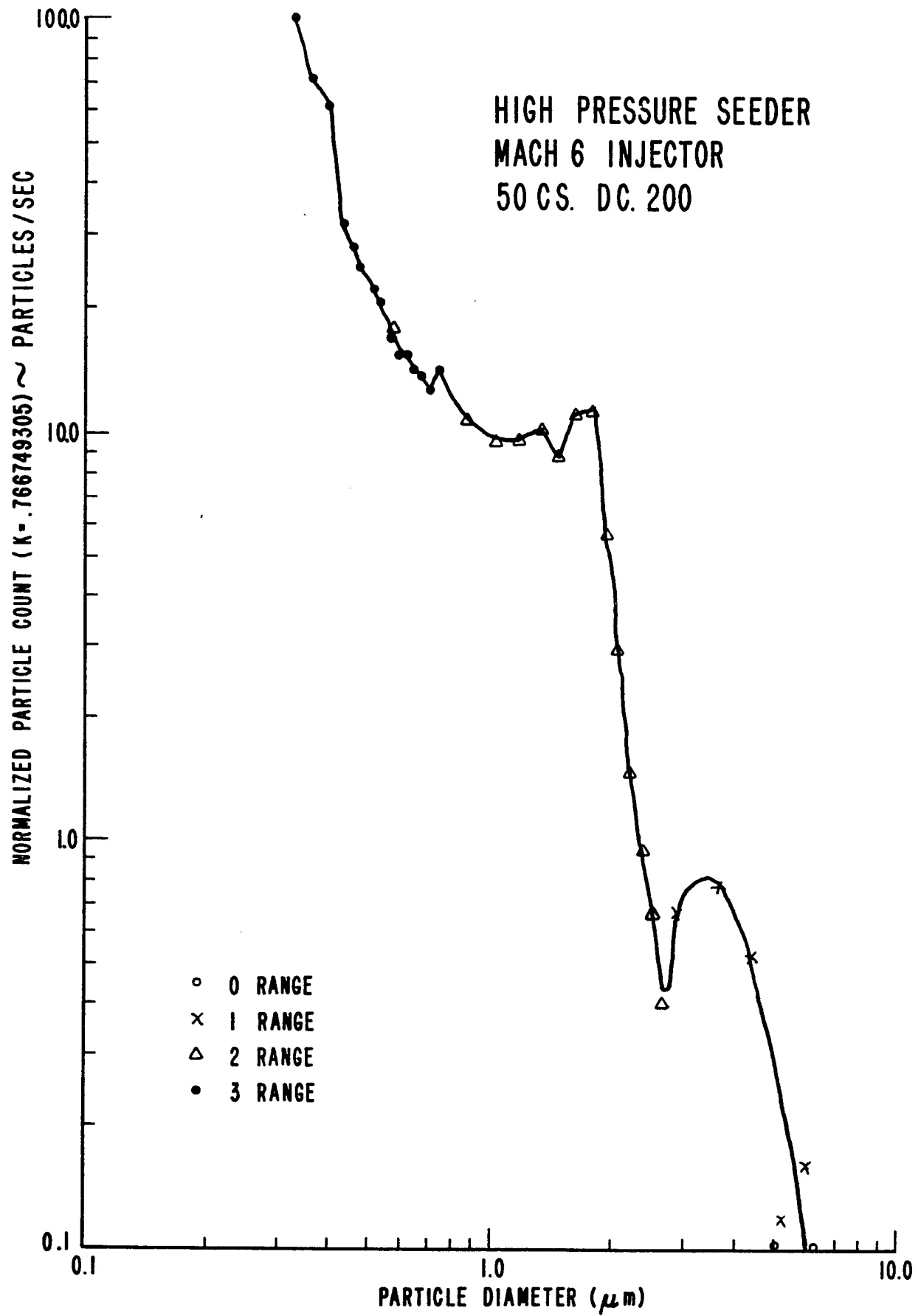

Figure 17 Mach 6 High Pressure Seeder Particle Sizing

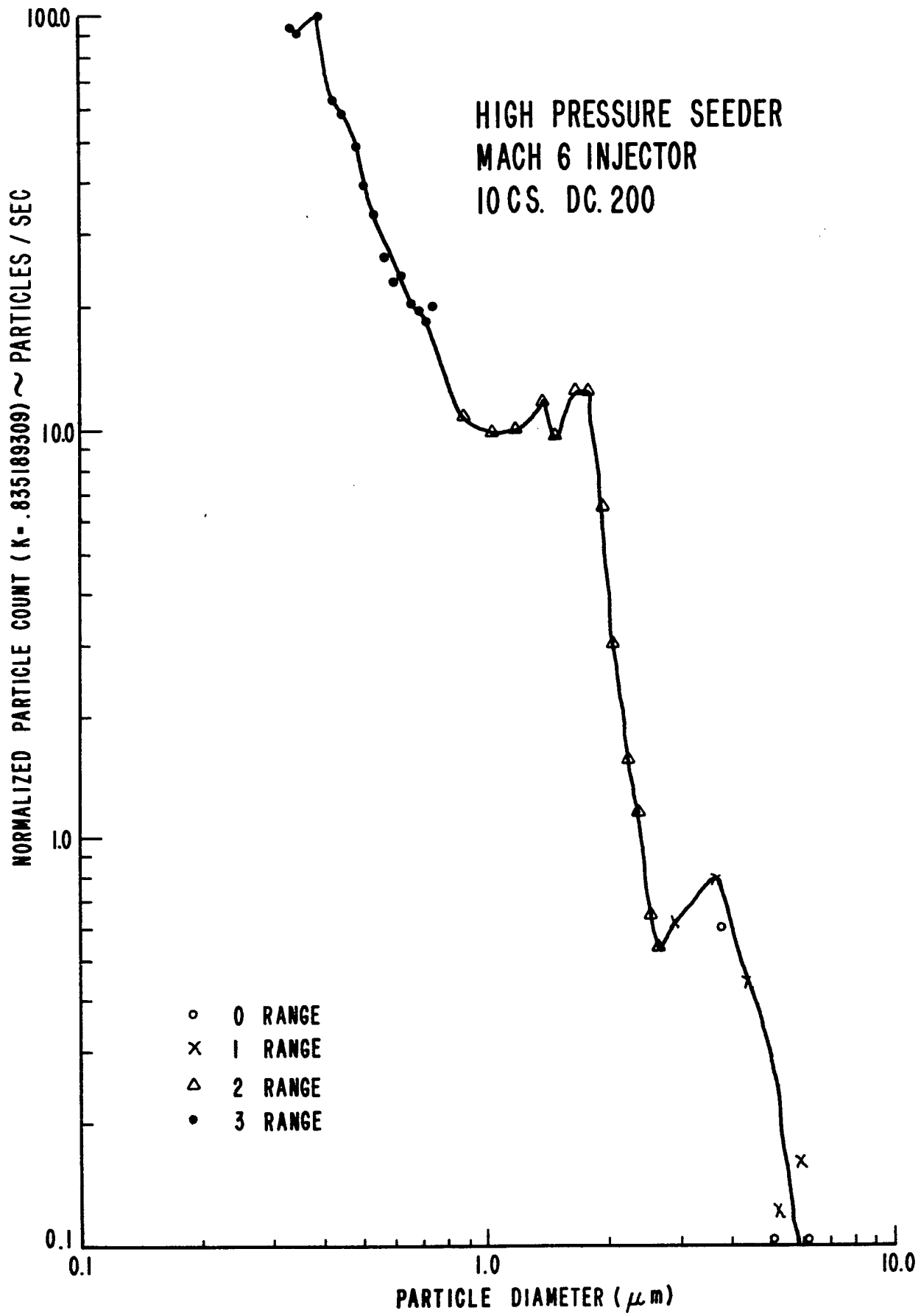

Figure 18 Mach 6 High Pressure Seeder Particle Sizing

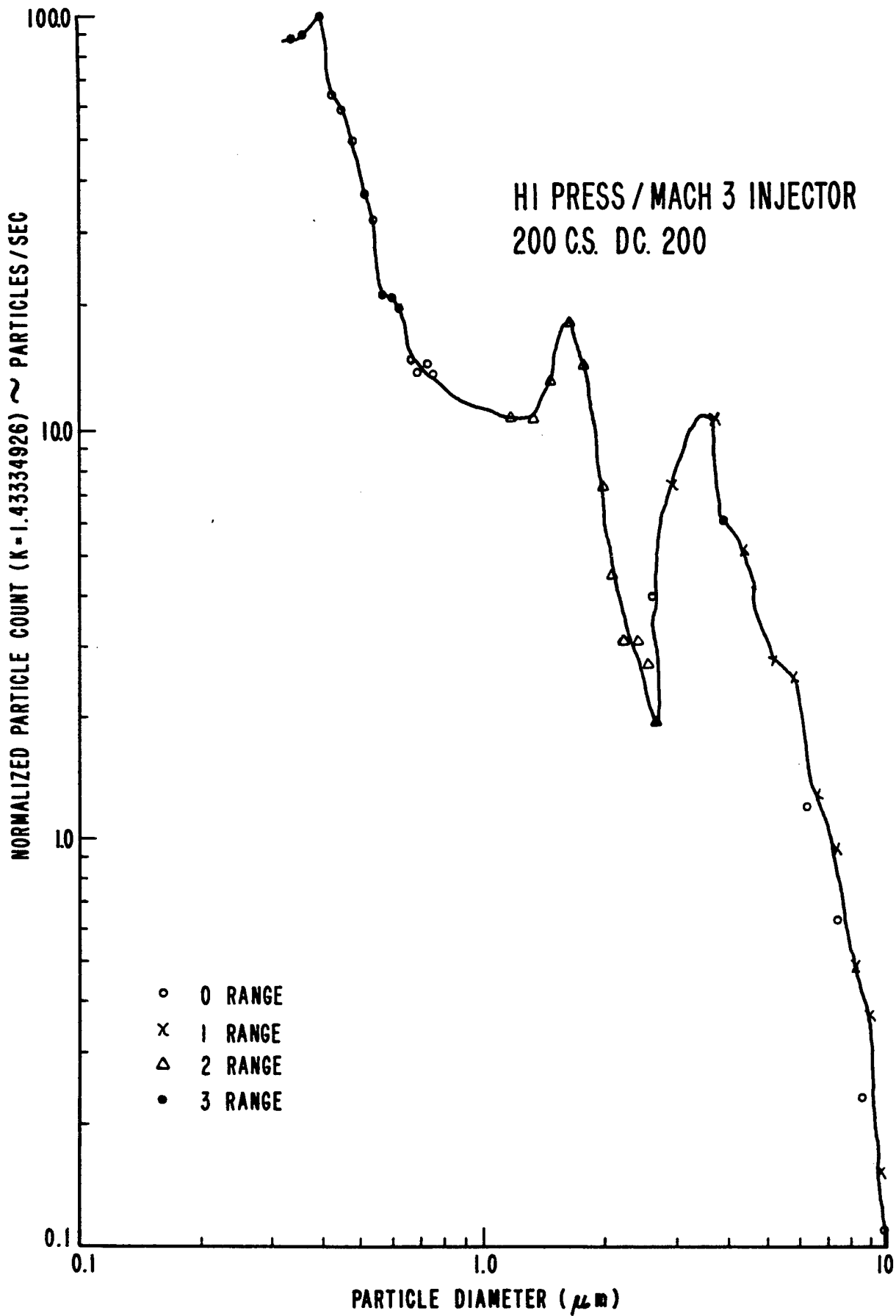

Figure 19 Mach 3 High Pressure Seeder Particle Sizing

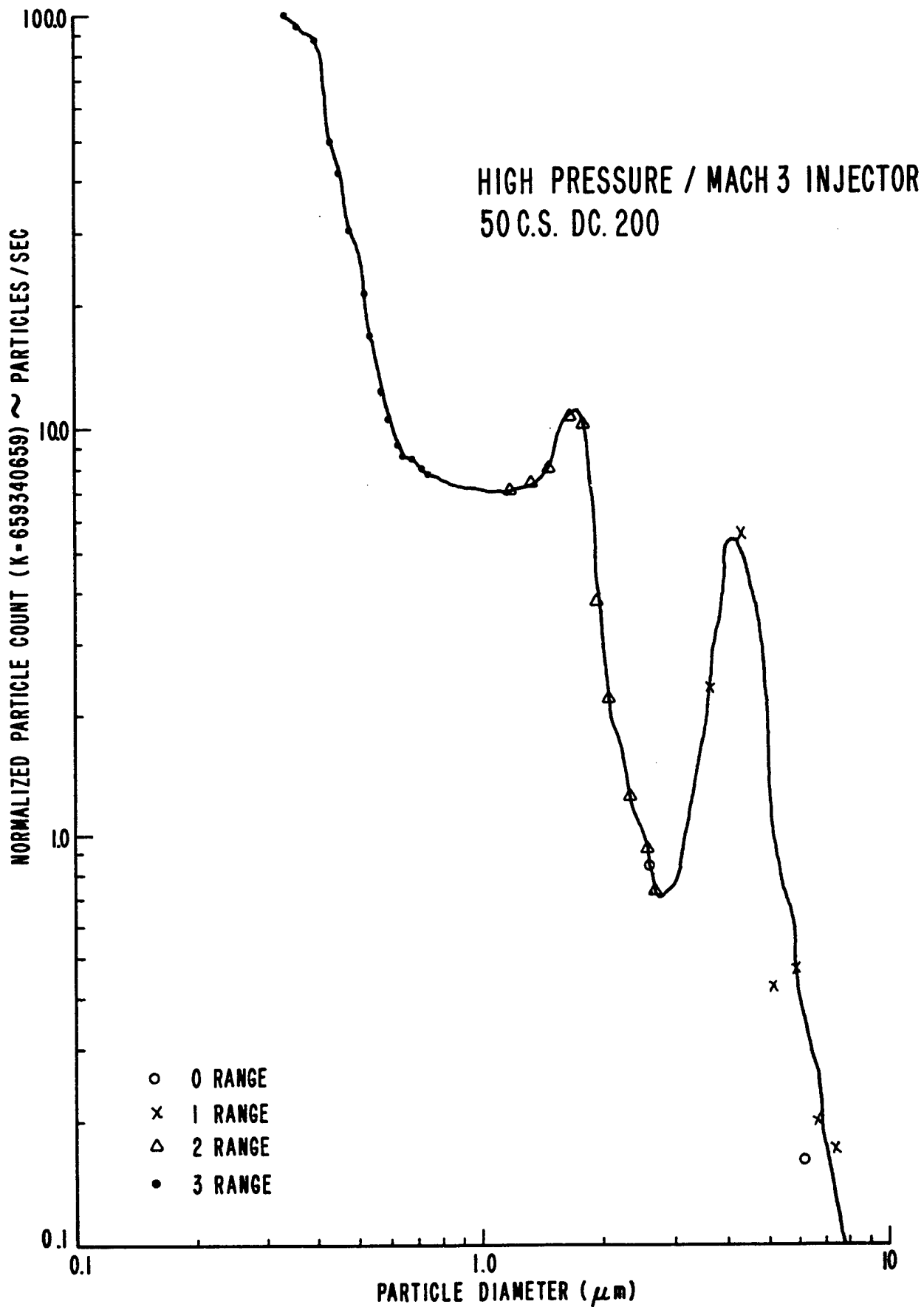

Figure 20 Mach 3 High Pressure Seeder Particle Sizing

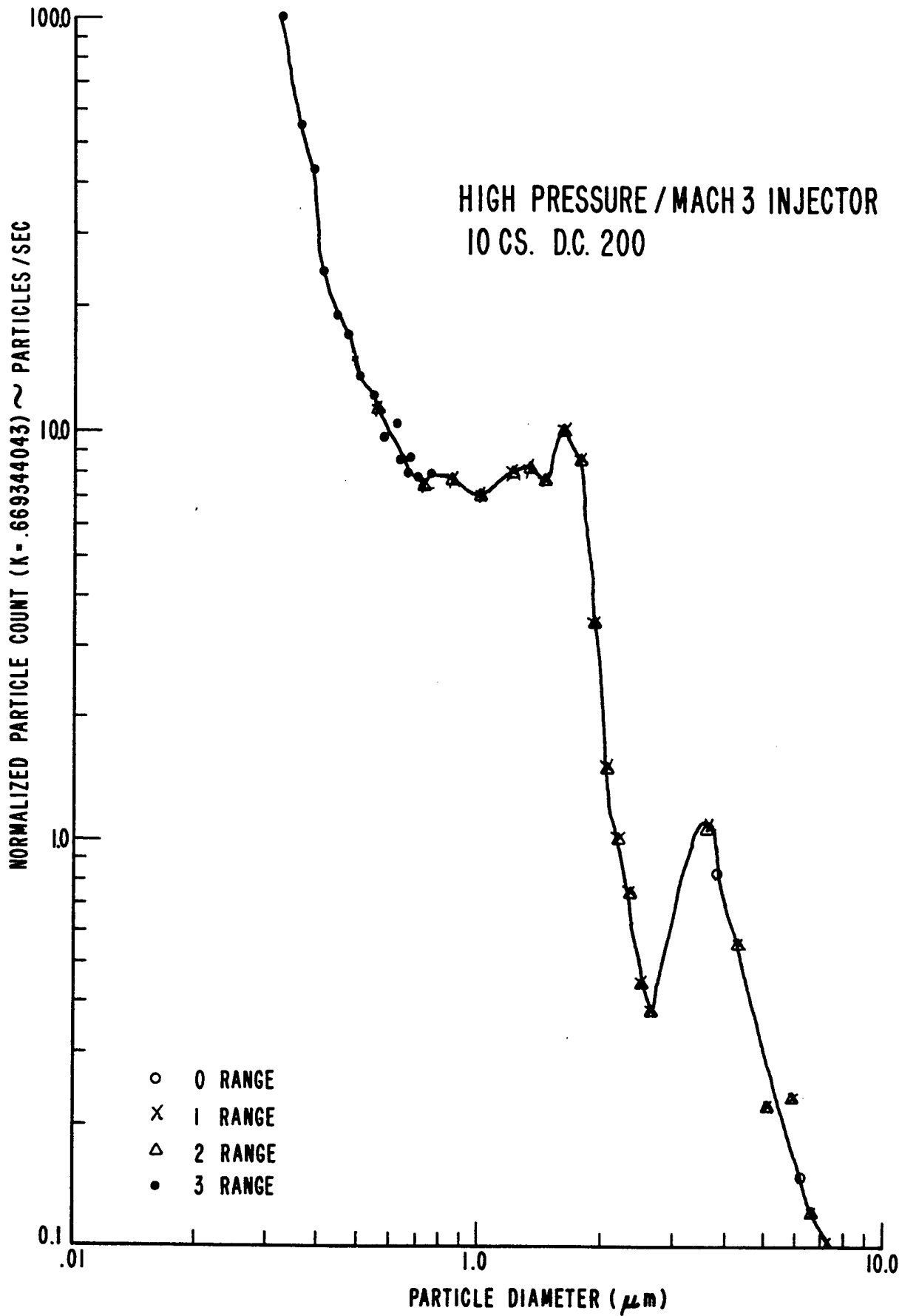

Figure 21 Mach 3 High Pressure Seeder Particle Sizing

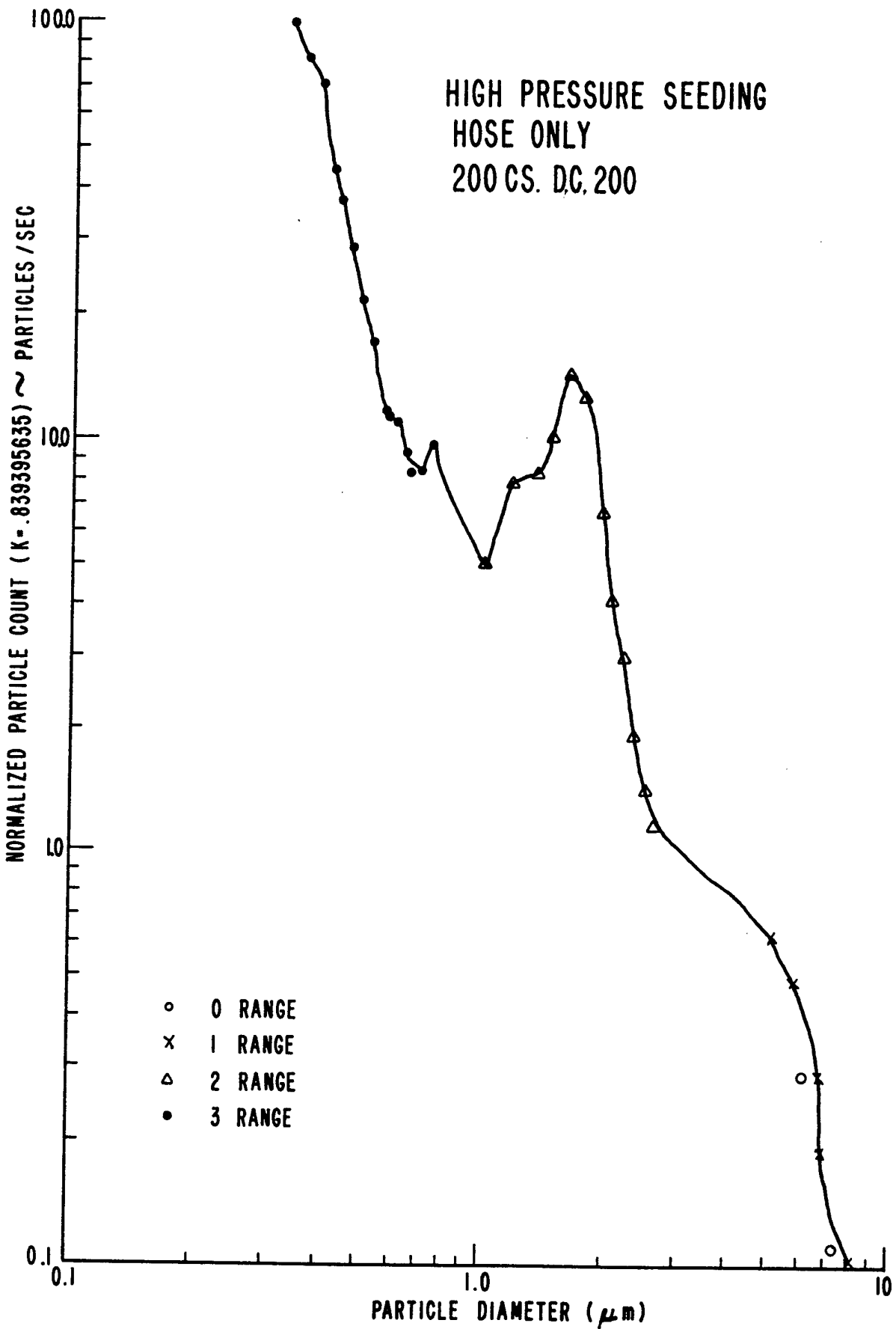

Figure 22 High Pressure Seeder Particle Sizing

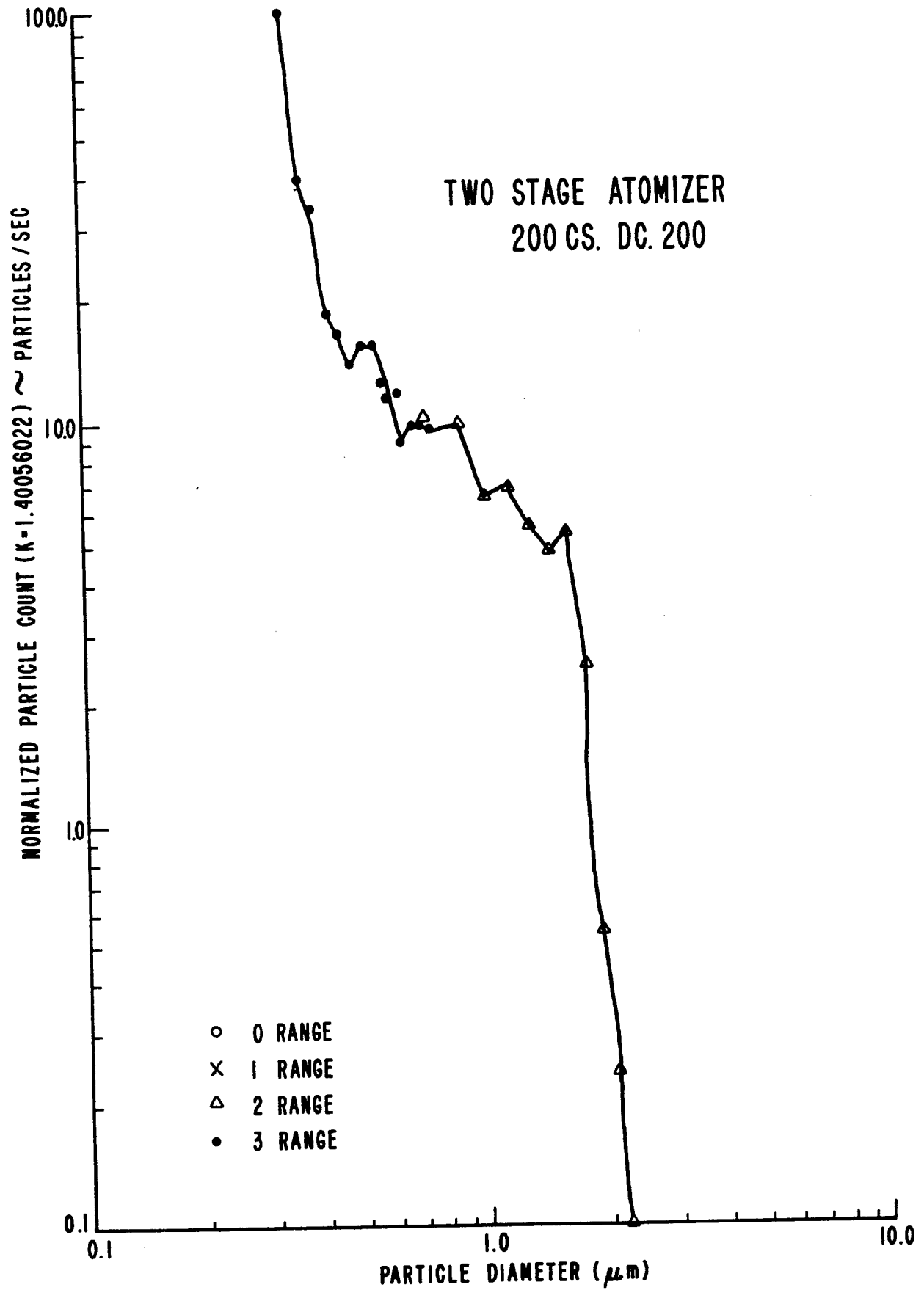

Figure 23 Two Stage Atomizer Particle Sizing

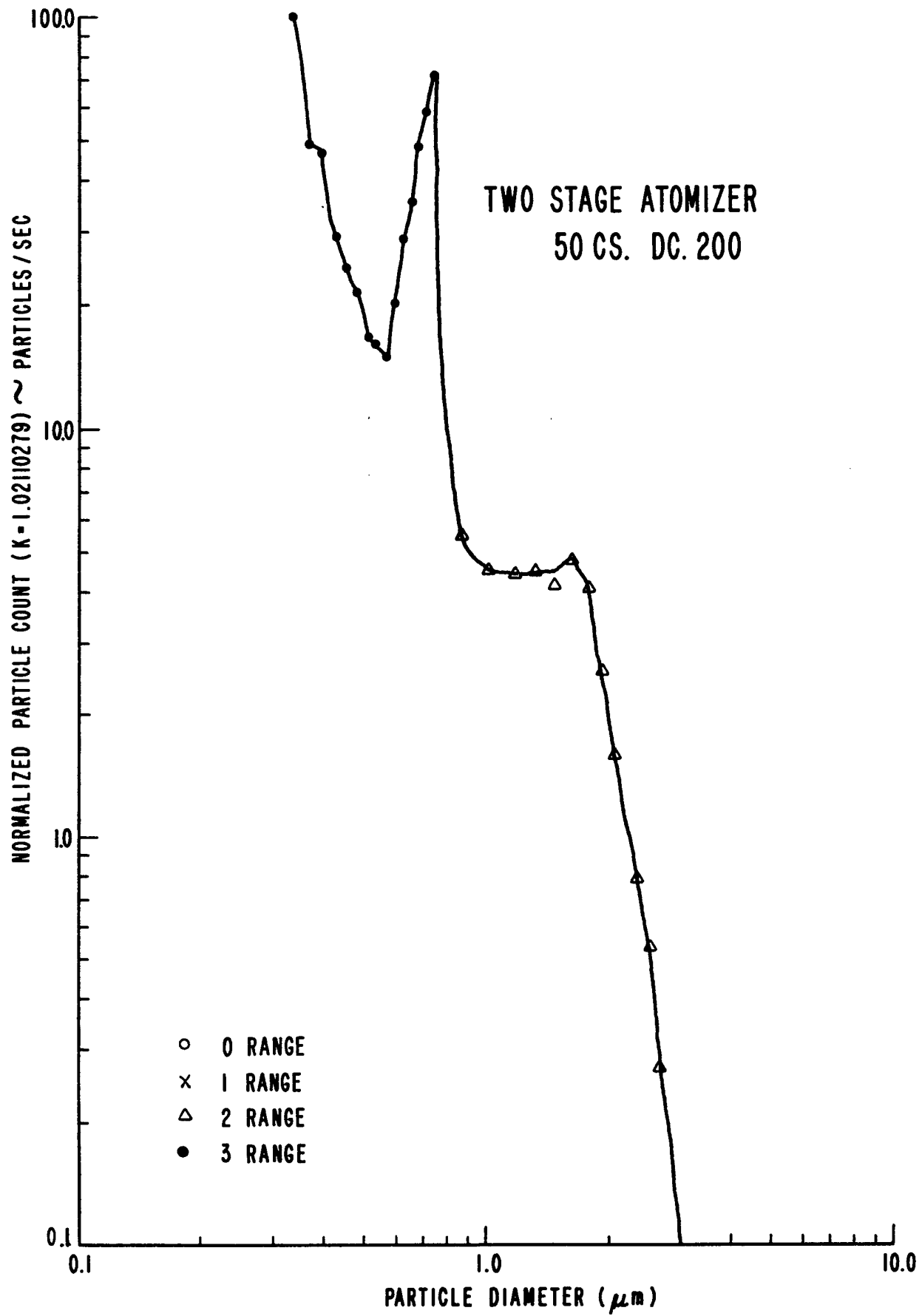

Figure 24 Two Stage Atomizer Particle Sizer

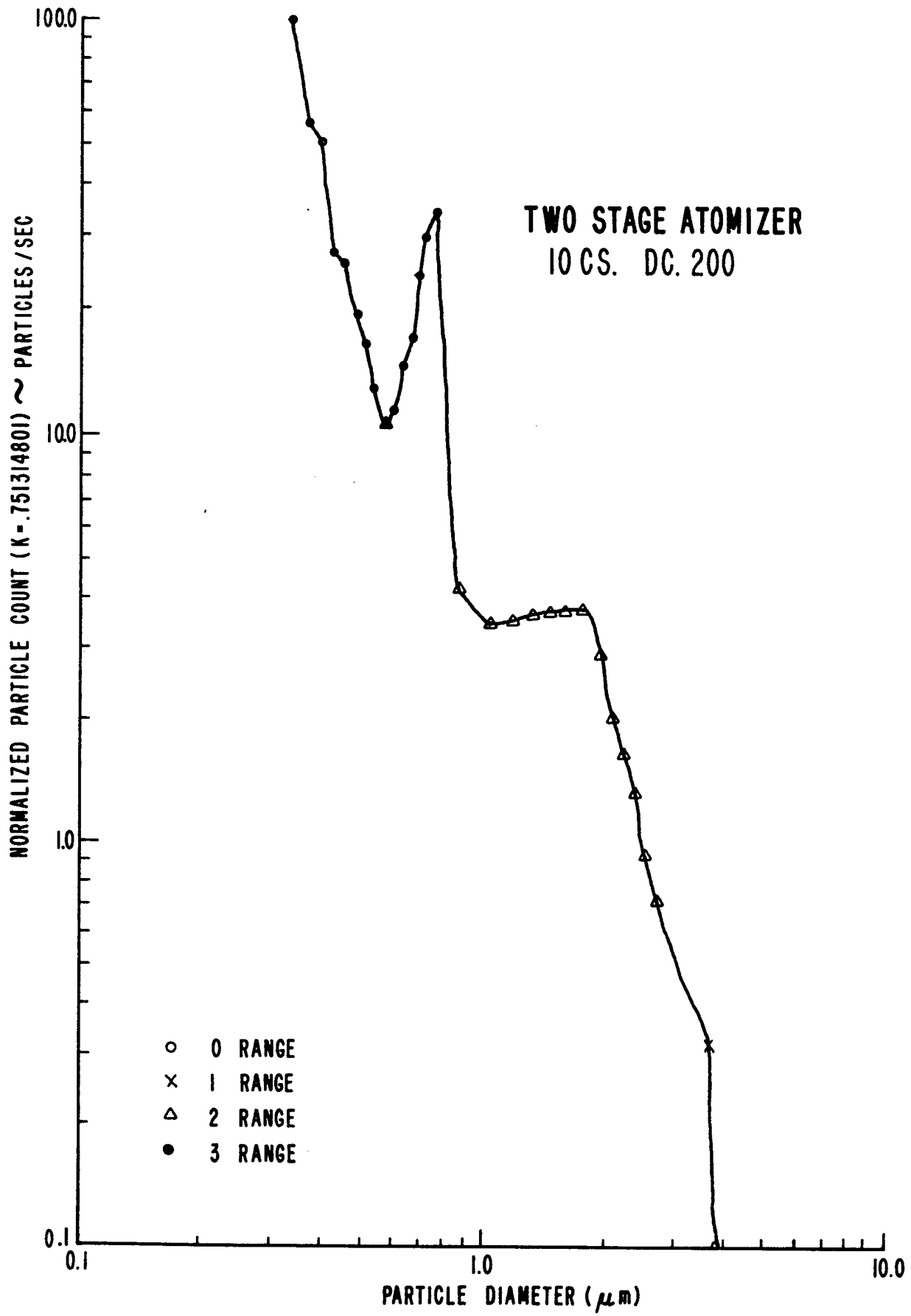

Figure 25 Two Stage Atomizer Particle Sizing

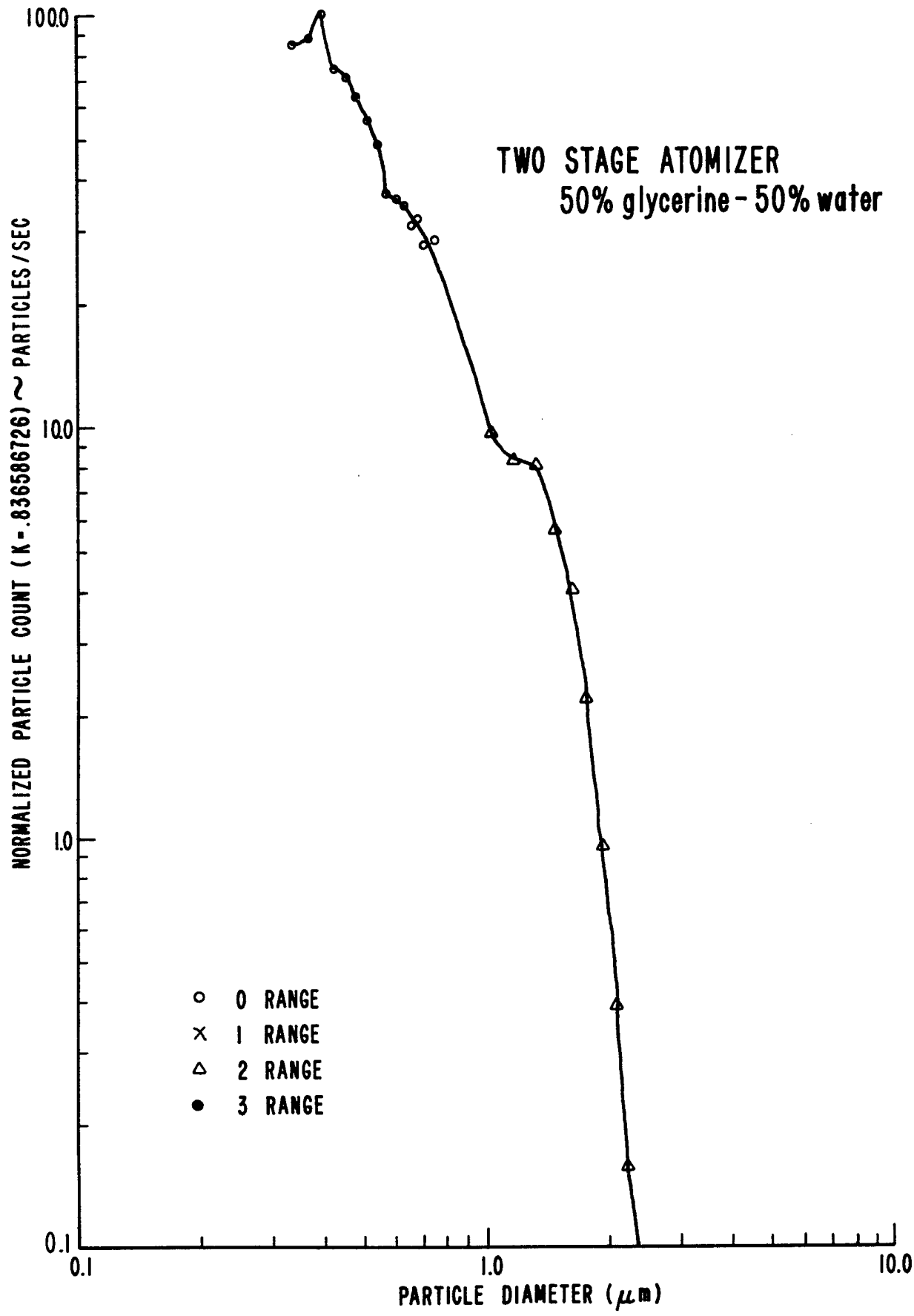

Figure 26 Two Stage Atomizer Particle Sizing

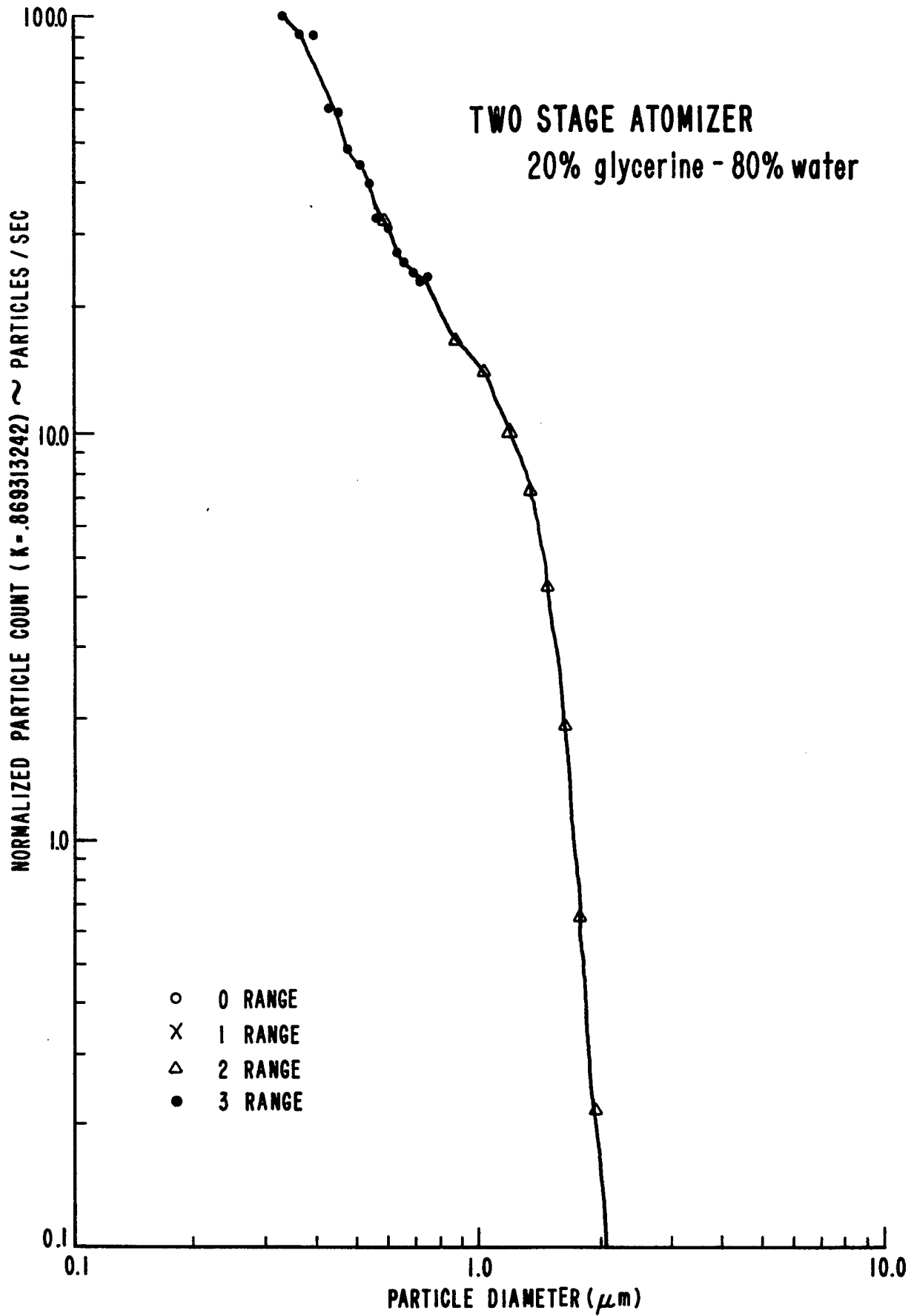
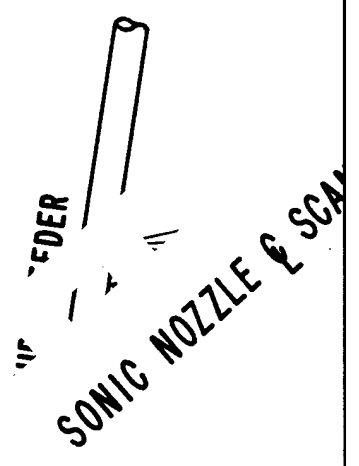
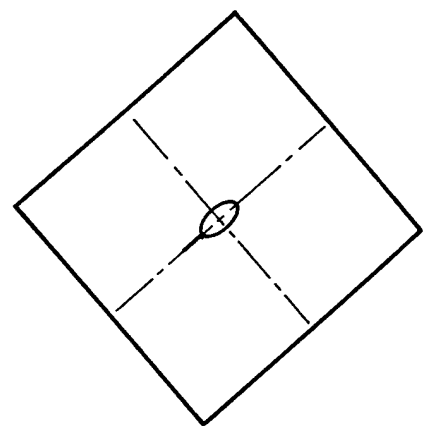
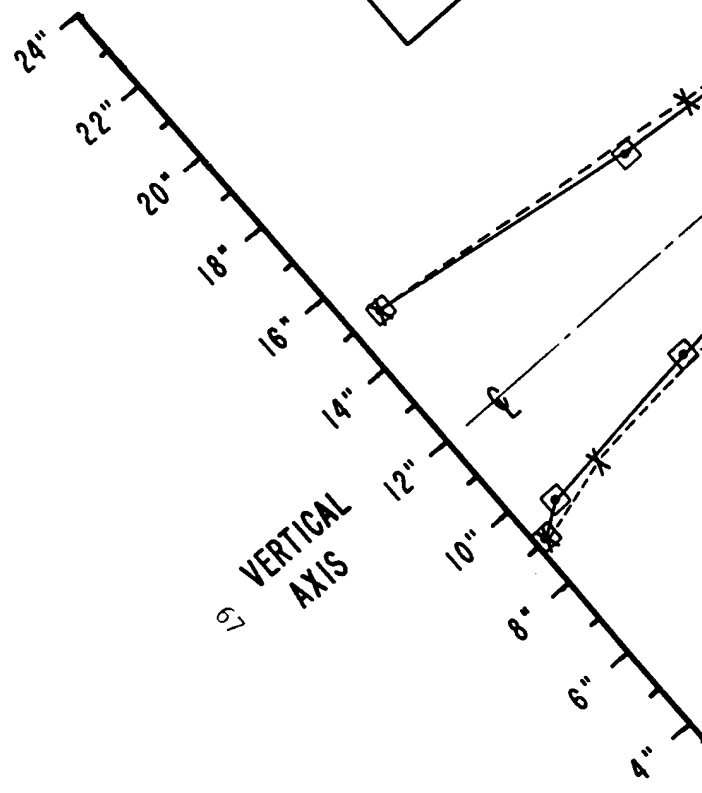
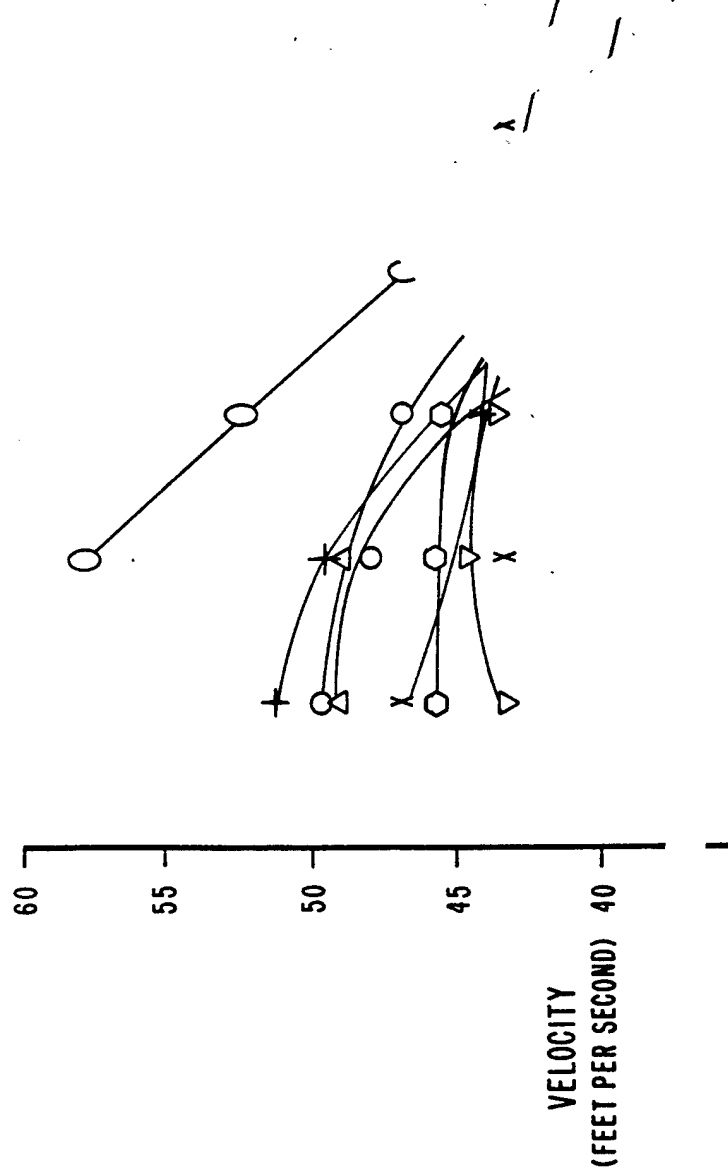
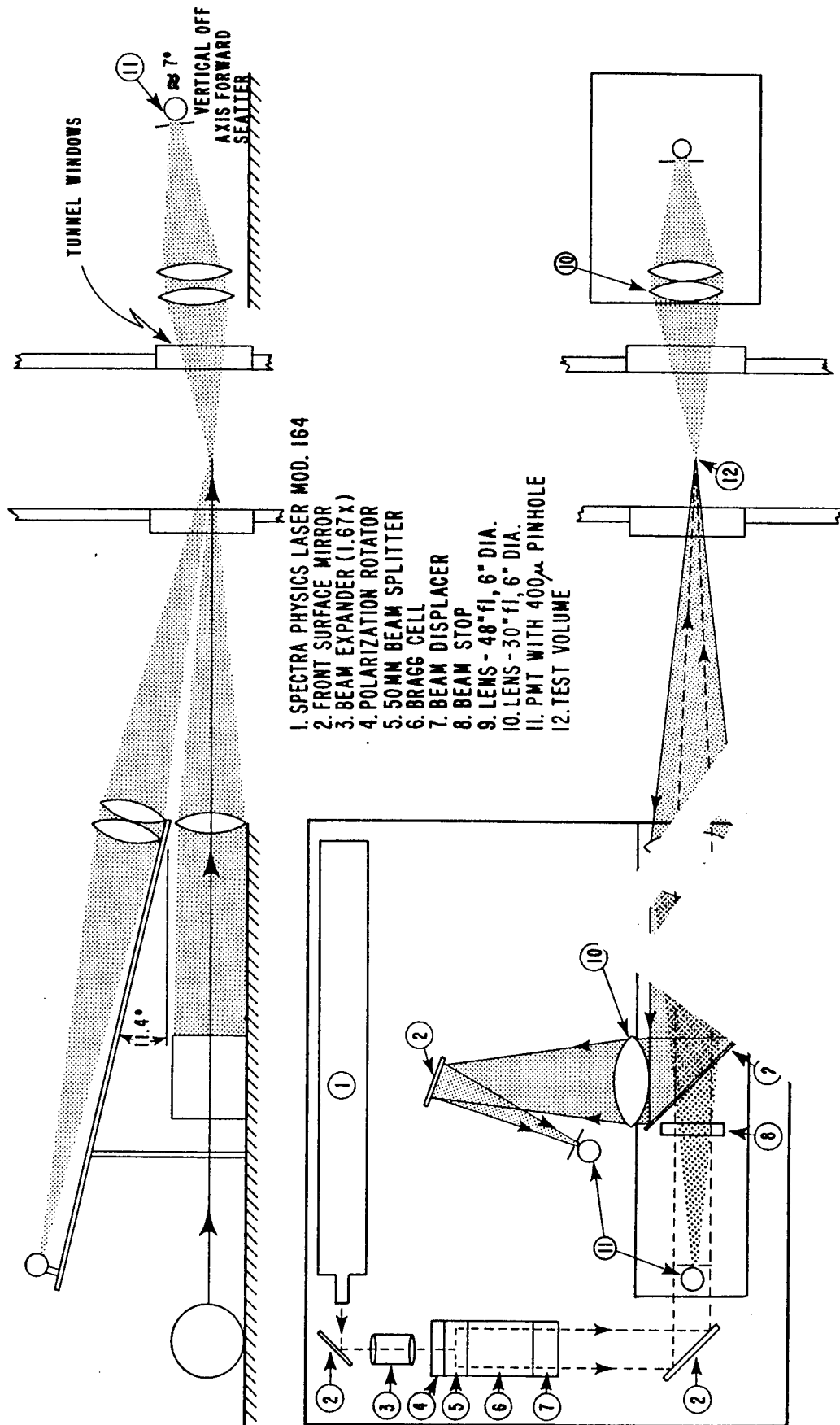

Figure 27 Two Stage Atomizer Particle Sizing

- SONIC NOZZLE W/ WATER
- SONIC NOZZLE W/ WATER-GLYCERINE (80-20)
- TWO STAGE ATOMIZER W/ WATER-GLYCERINE (50-50)
- △ SONIC NOZZLE W/ DC 200 (200CS)
- + SONIC NOZZLE W/ DC 200 (10CS)
- ▽ HIGH PRESSURE SEEDER W/DC 200 (200 CS)
- x HIGH PRESSURE SEEDER W/DC 200 (10 CS)





Ba tter in TGF

24"
22"

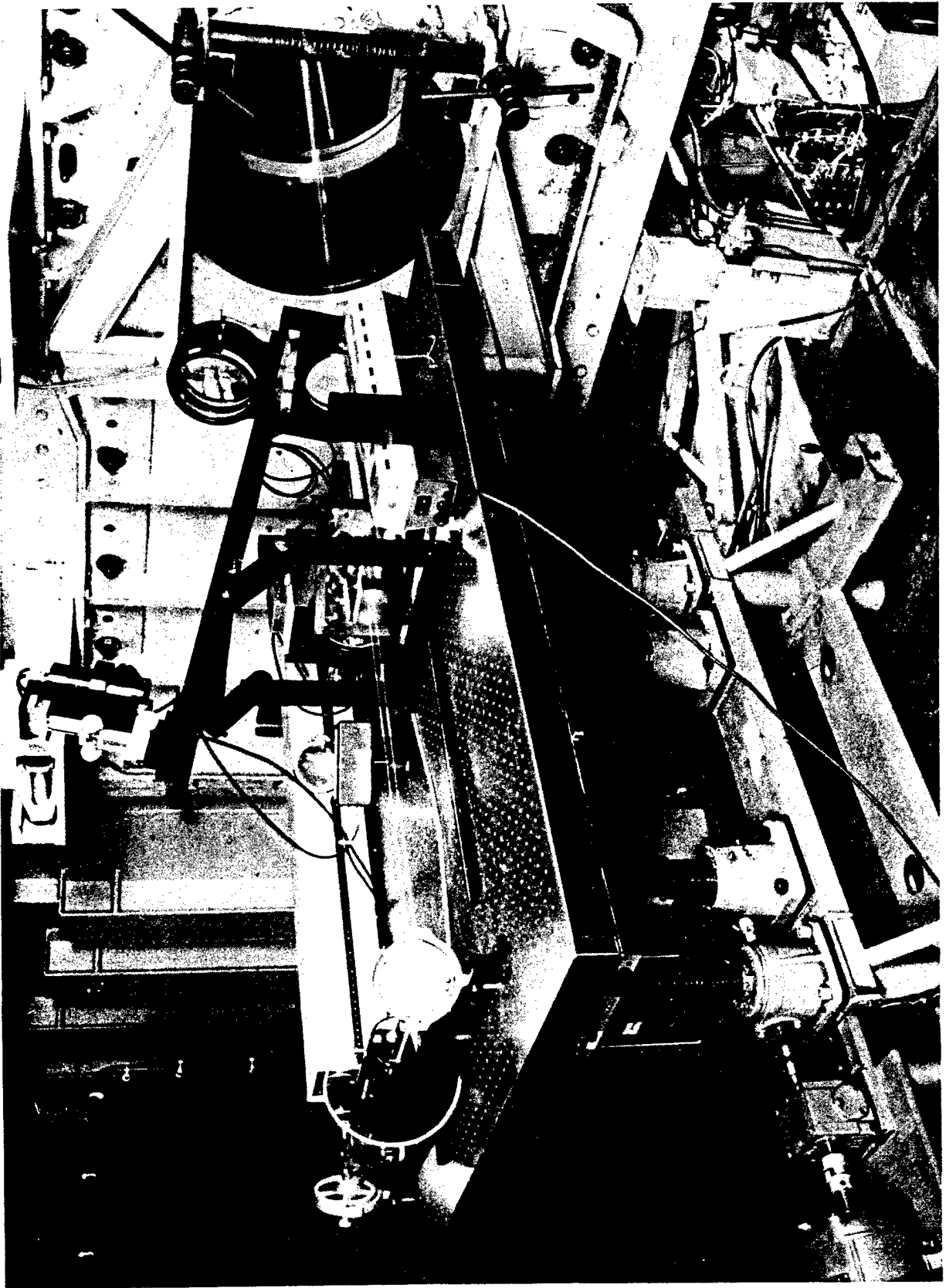

Figure 30 Single Component LV Backscatterer in TGF

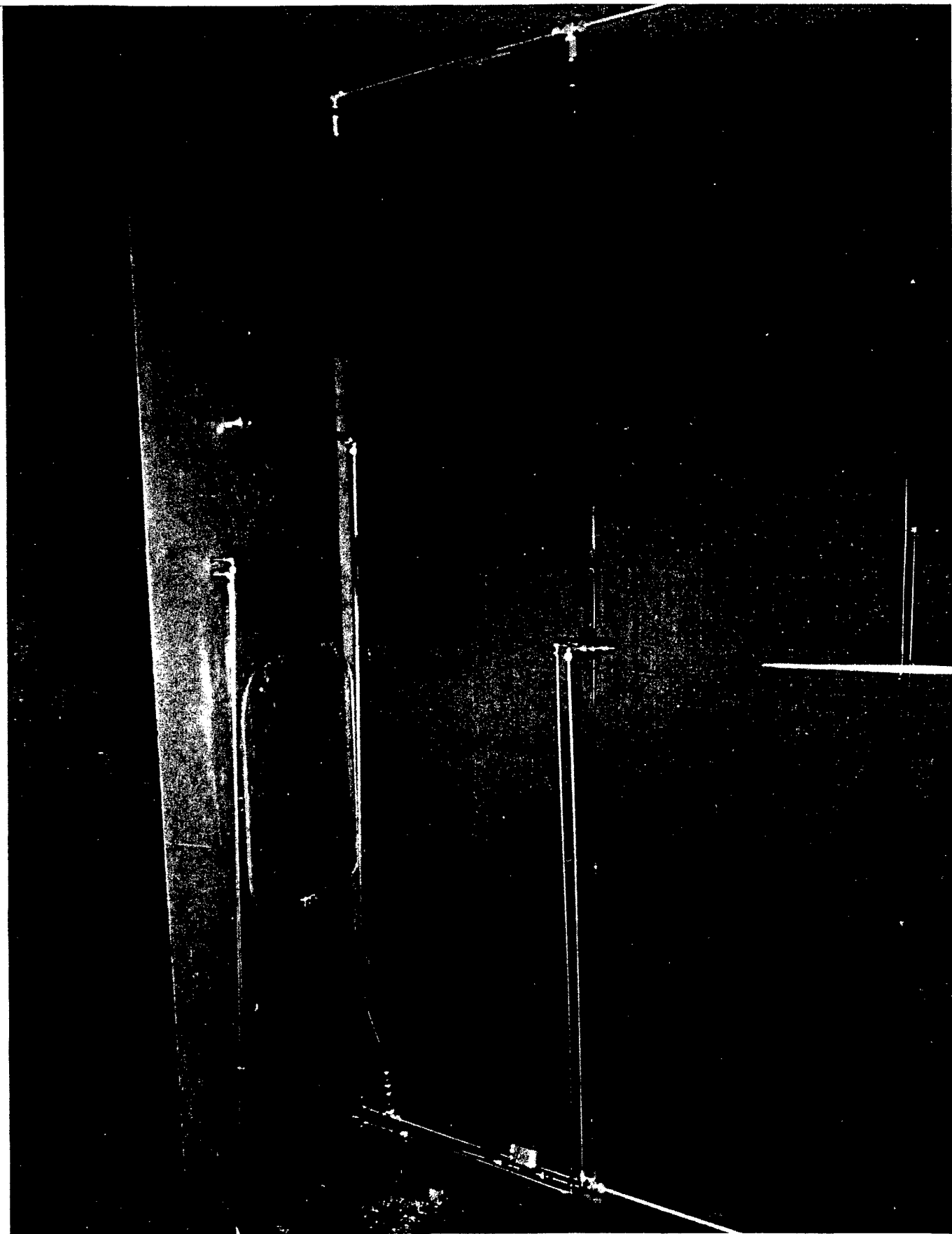
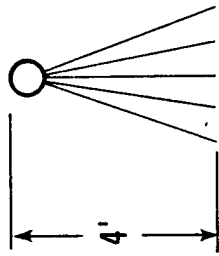
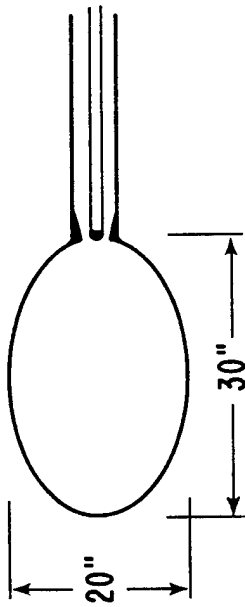

Figure 31 Seeder Installations in TGF Plenum

FLOW SEEDING TEST IN TGF

SONIC NOZZLE



HIGH PRESSURE SEEDER

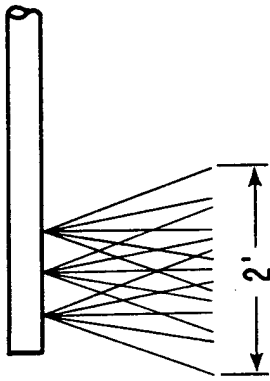

SEED PATTERN IN TEST SECTION

SONIC NOZZLE

OIL USED - 1CC/MIN

LV DATA COUNTS:

FWD. SCATTER - 120 K/SEC (F-5)

BACK SCATTER - 300 /SEC (F-8)

PARTICLE SIZE 2μ

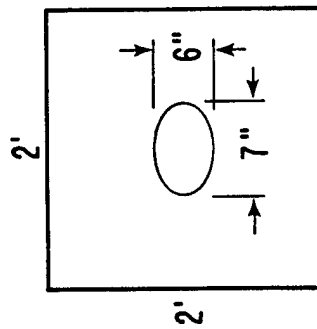

HIGH PRESSURE SEEDER

OIL USED - 2-5CC/MIN

LV DATA COUNTS:

FWD. SCATTER - 120 K/SEC (F-5)

BACK SCATTER - 1,000/SEC (F-8)

PARTICLE SIZE = 2-6 μ

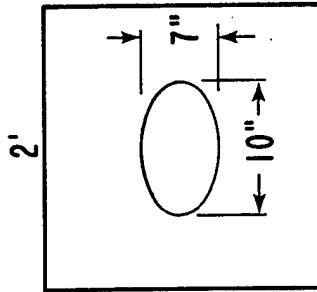

STAGNATION REGION SEED PATTERNS (SONIC NOZZLE)

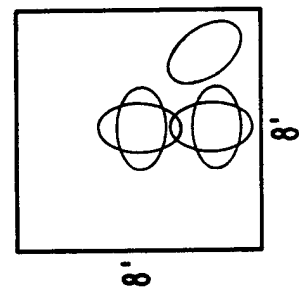

POSITIONS TESTED

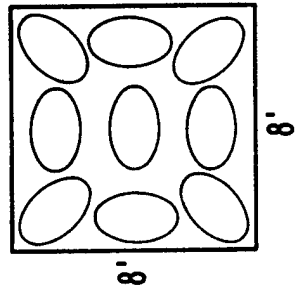

9 NOZZLES

NEED FOR UNIFORM T.S. SEEDING
(10CC/MIN OF OIL)

Figure 32 Seed Injector Configurations in TGF

**SONIC NOZZLE
1/2 SCAN**

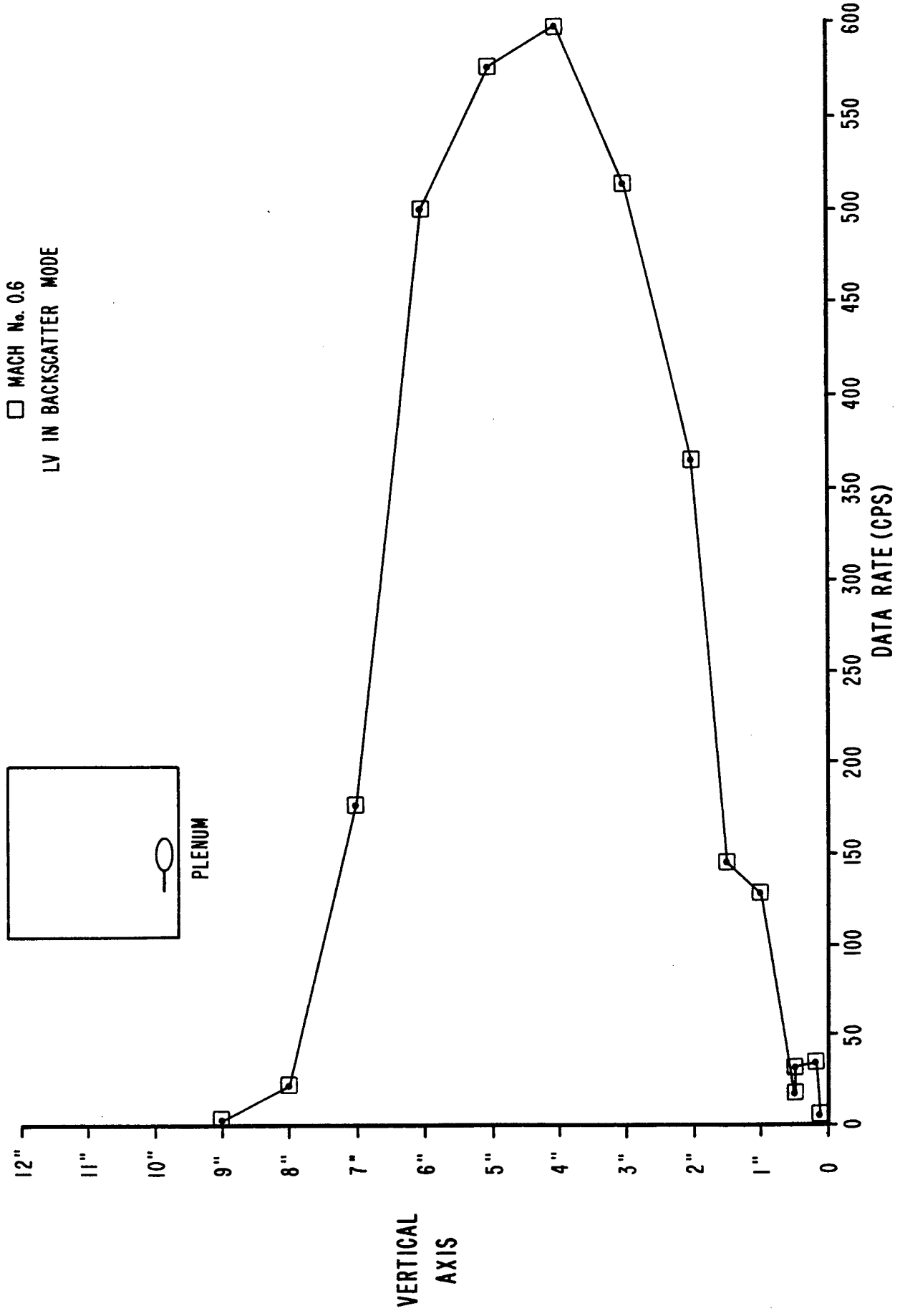
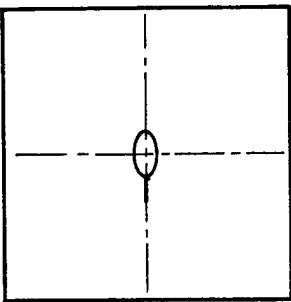

Figure 33 Local Seeding in TGF with Sonic Nozzle

SONIC NOZZLE & SCAN



MACH No. 0.6
 LV IN BACKSCATTER MODE
 OIL FEED RATE
 X 2 cc/min.
 □ 0.7 cc/min.

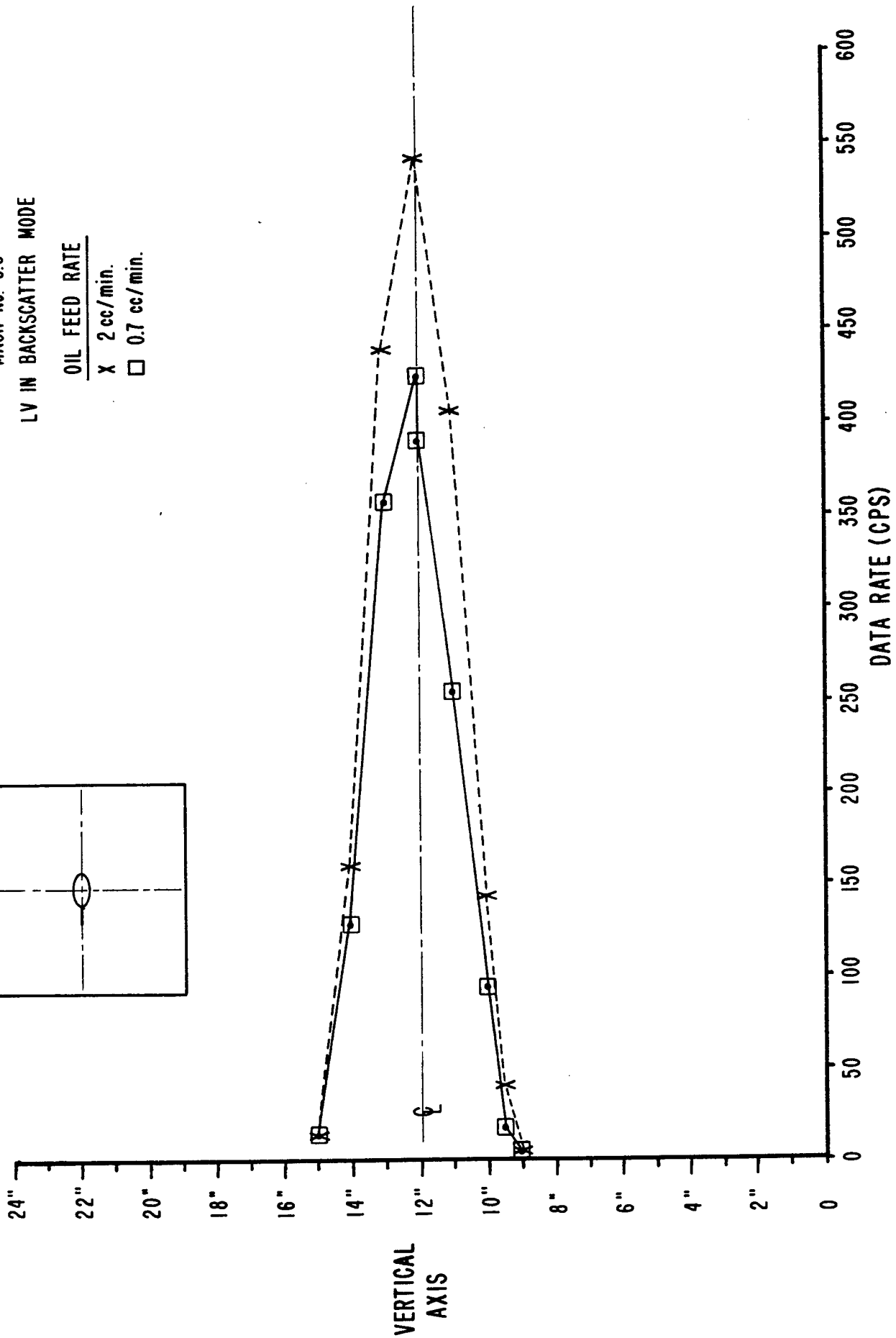
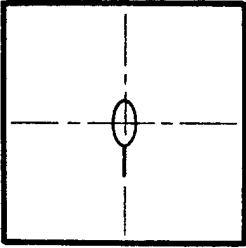
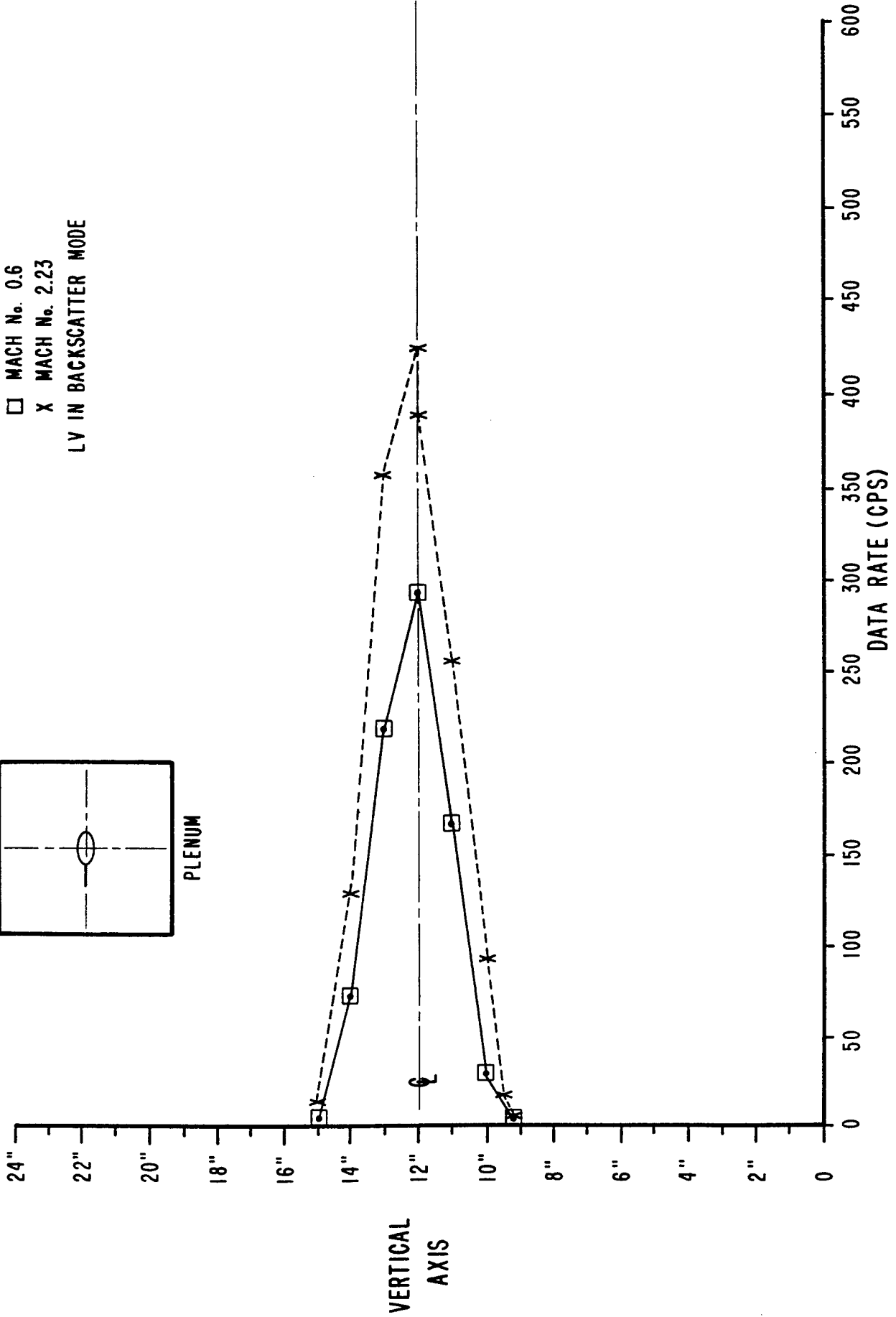

Figure 34 Local Seeding in TGF with Sonic Nozzle

**SONIC NOZZLE
ϕ SCAN**



PLENUM



□ MACH No. 0.6
 X MACH No. 2.23
 LV IN BACKSCATTER MODE

Figure 35 Local Seeding in TCF with Sonic Nozzle

BOUNDARY LAYER SURVEY FORWARD SCATTER vs BACK SCATTER

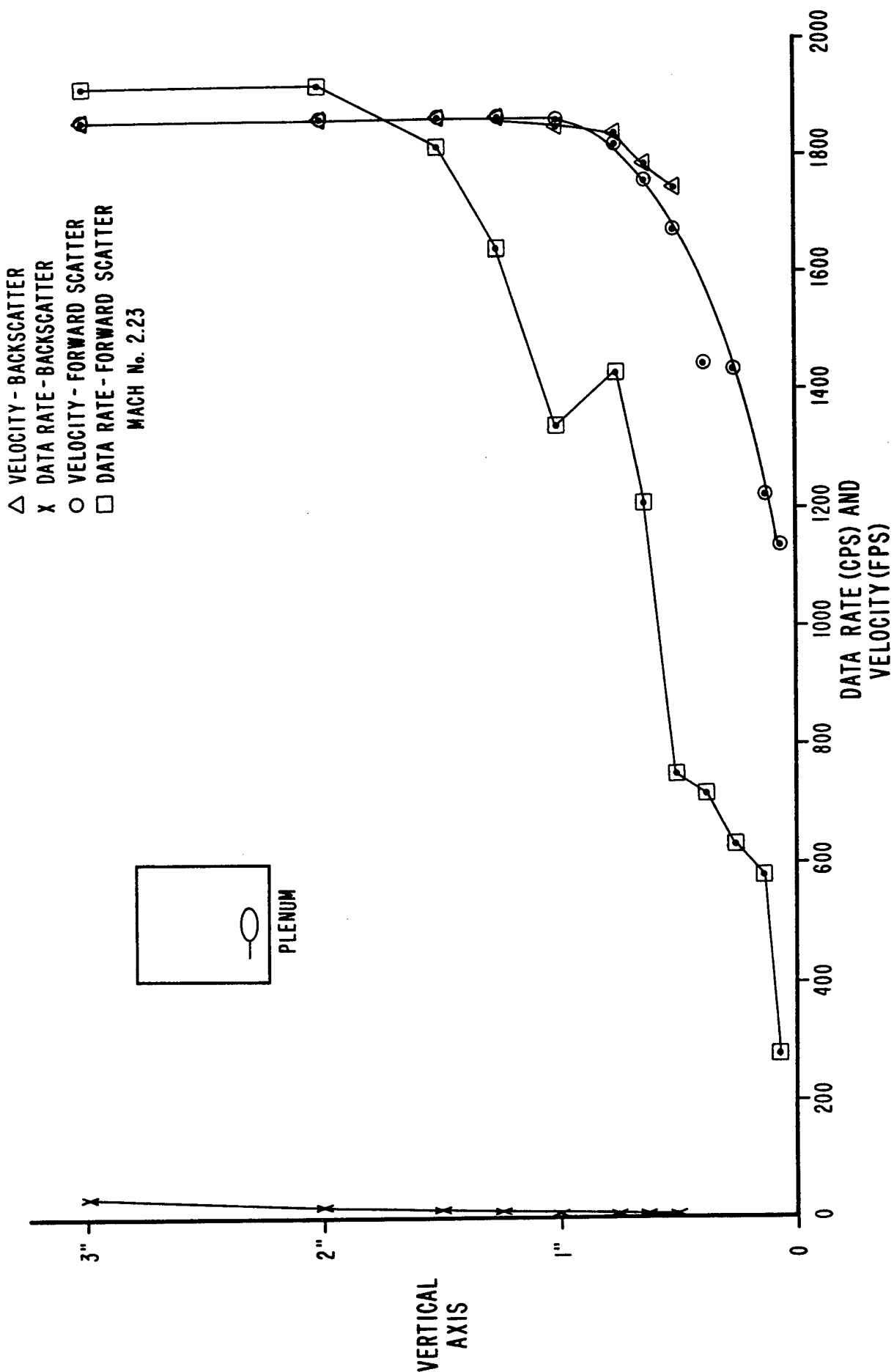
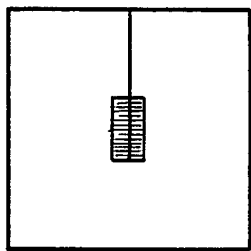

Figure 36 Data Rates in TGF Boundary Layer with Sonic Nozzle Seeding and LV in Forward and Backscatter Modes

HIGH PRESSURE SEEDER & SCAN 300 psig



□ MACH No. 0.6
 X MACH No. 2.23
 LV IN BACKSCATTER MODE

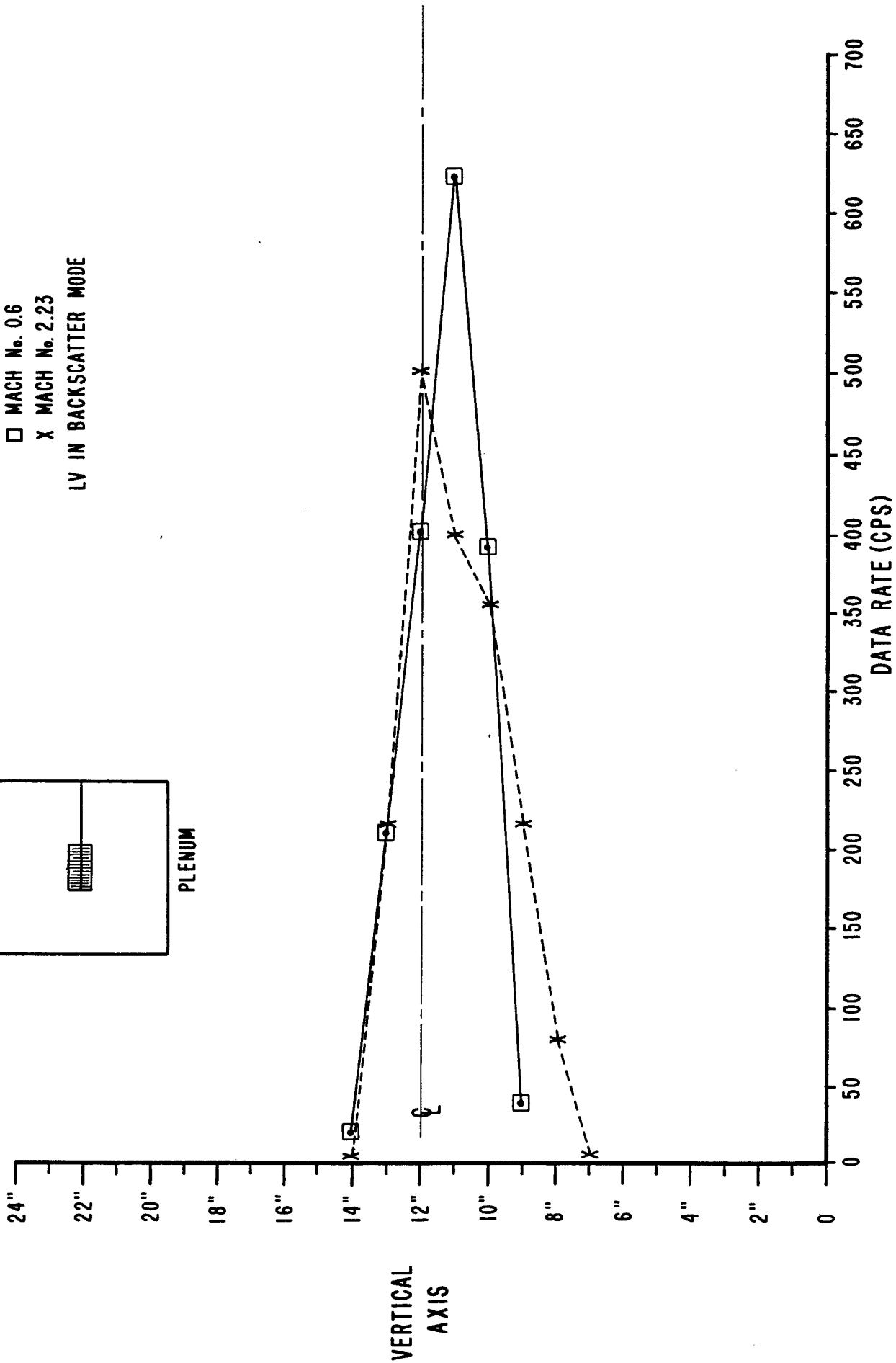
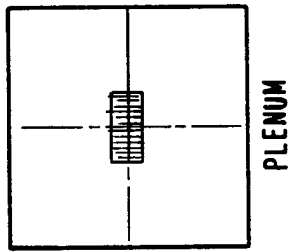

Figure 37 Local Seeding in TGF with High Pressure Seeder

HIGH PRESSURE SEEDER ϕ SCAN



X 300 psig
 □ 500 psig
 MACH No. 0.6
 LV IN BACKSCATTER MODE

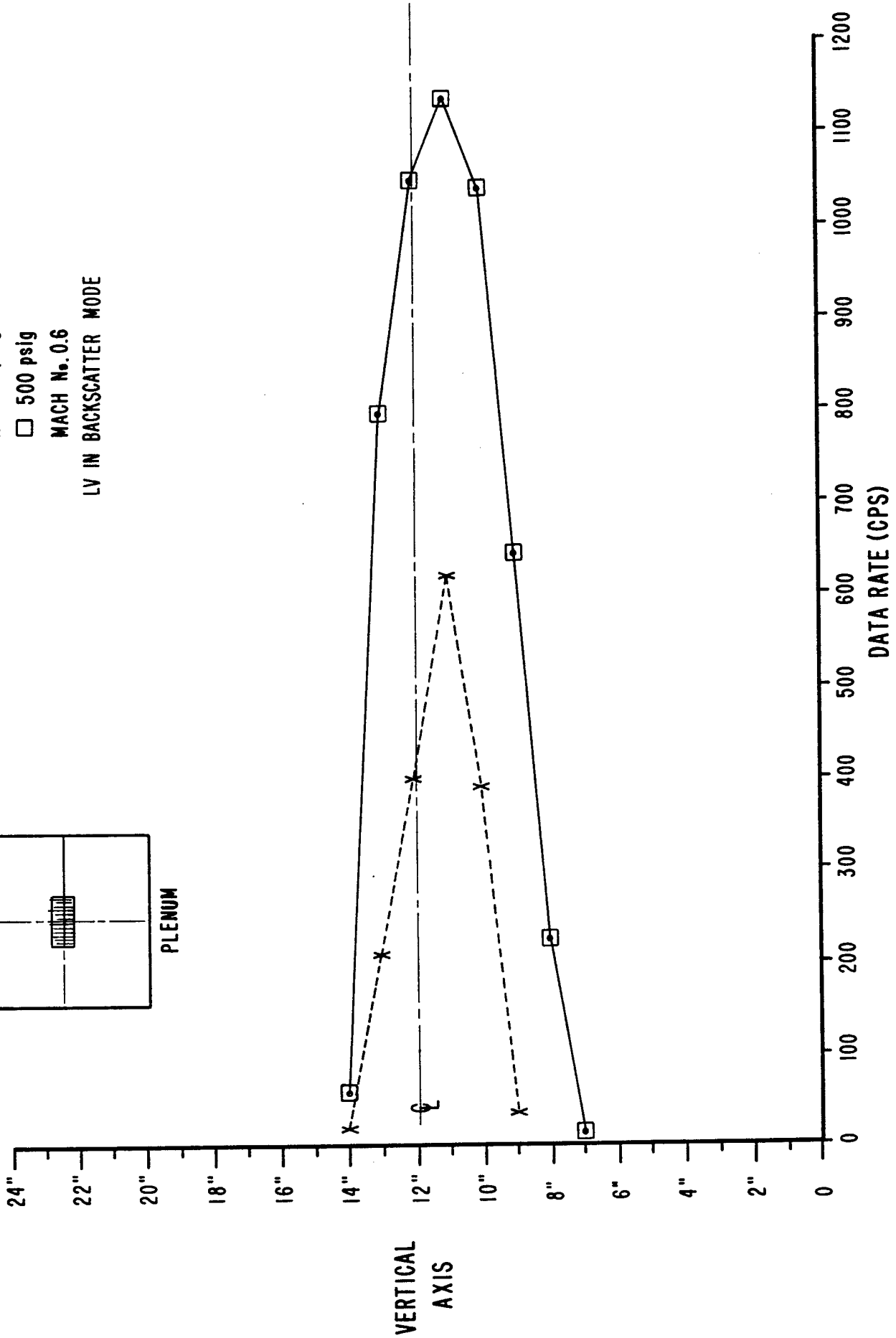
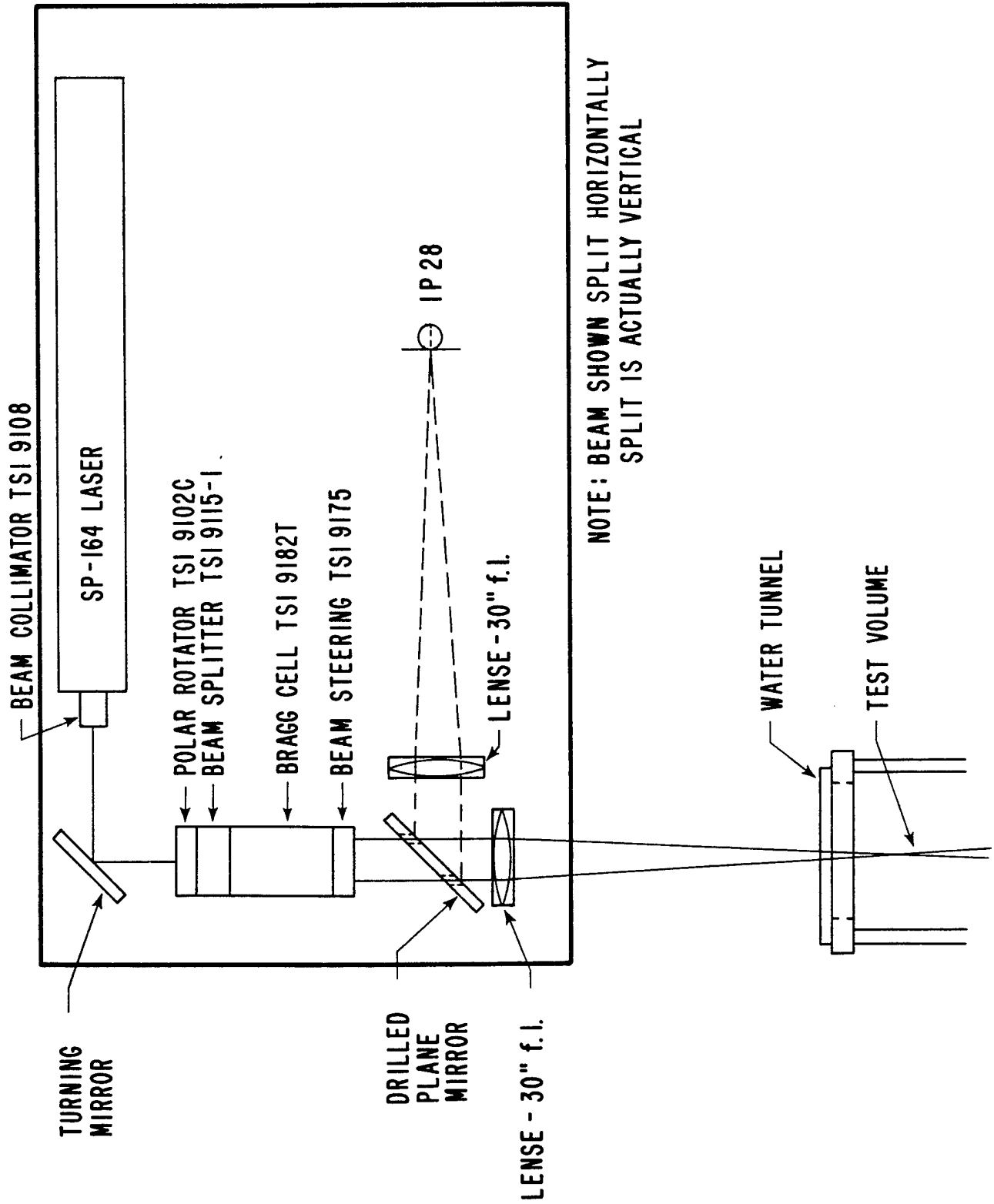

Figure 38 Local Seeding in TGF with High Pressure Seeder

SINGLE COMPONENT L.D.V. - WATER TUNNEL



**NOTE: BEAM SHOWN SPLIT HORIZONTALLY
SPLIT IS ACTUALLY VERTICAL**

Figure 39 Single Component LV Used in 6" Prototype Water Tunnel

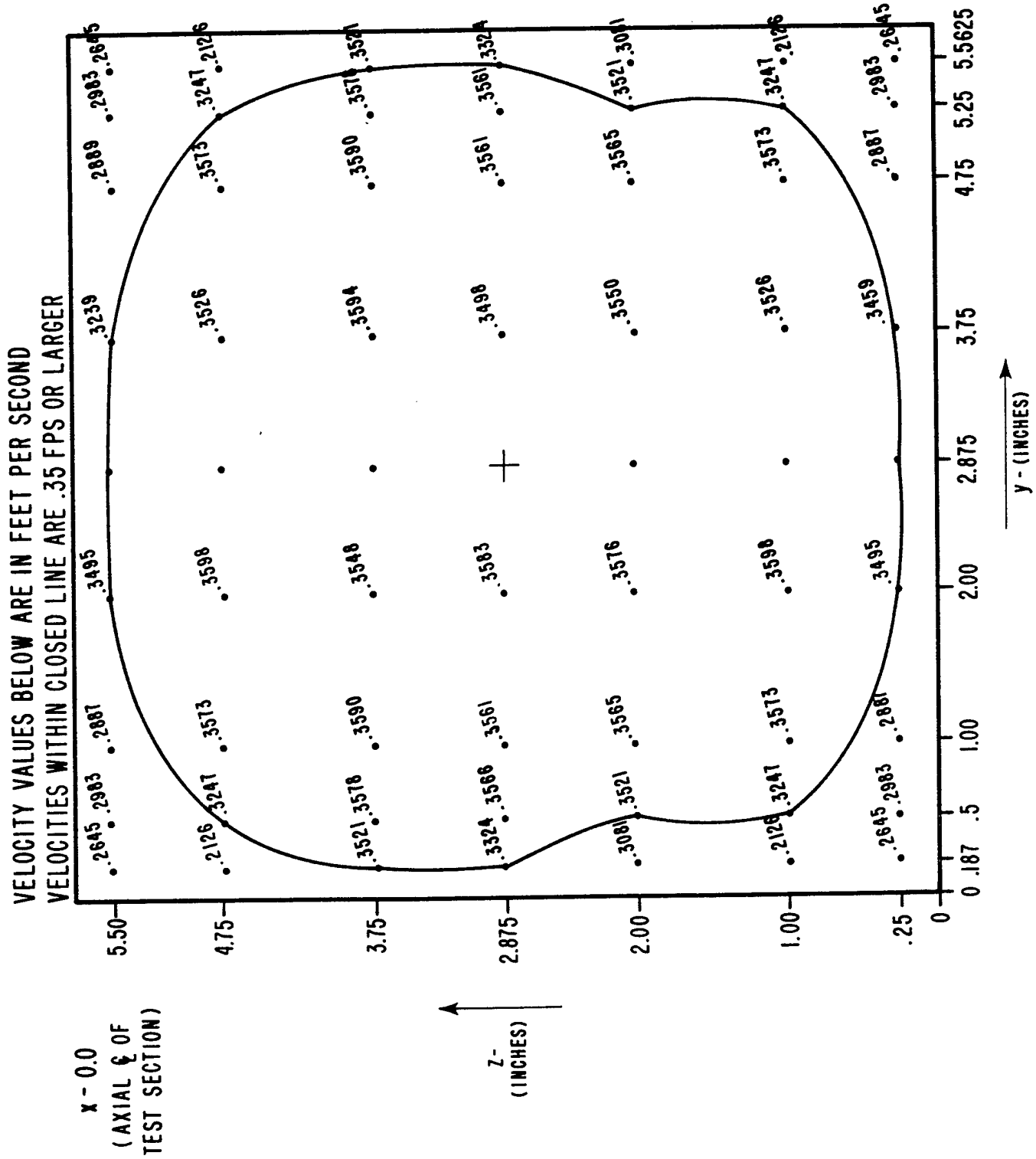

Figure 40 Velocity Map of Lateral Plane at Axial Center of 6" Prototype Water Tunnel Test Section