

OPTICAL WORK.
on
UNUSUALLY LARGE GLASS PLATES

An Interference Method of Investigating
High-Quality Flat Surfaces

Theodor W. Zobel
Ferdinand M. Mirus

DISTRIBUTION STATEMENT A
Approved for Public Release
Distribution Unlimited

Reproduced From
Best Available Copy

20000515 042

United States Air Force
Air Materiel Command
Wright-Patterson Air Force Base, Dayton, Ohio

NOTE

When drawings, specifications, and other data prepared by the War Department are furnished to manufacturers and others for use in the manufacture or purchase of supplies, or for any other purpose, the Government assumes no responsibility nor obligation whatever; and the furnishing of said data by the War Department is not to be regarded by implication or otherwise, or in any manner licensing the holder, or conveying any rights or permission to manufacture, use, or sell any patented inventions that may in any way be related thereto.

The information furnished herewith is made available for study upon the understanding that the Government's proprietary interests in and relating thereto shall not be impaired. It is desired that the Patent & Royalties Section, Office of the Judge Advocate, Air Materiel Command, Wright-Patterson AFB, Dayton, Ohio, be promptly notified of any apparent conflict between the Government's proprietary interests and those of others.

Espionage Act

Notice: "This document contains information affecting the national defense of the United States within the meaning of the Espionage Act, 50 U. S. C., 31 and 32, as amended. Its transmission or the revelation of its contents in any manner to an unauthorized person is prohibited by law."

"The above Espionage Notice can be disregarded unless this document is plainly marked with a security classification as "Restricted," "Confidential," "Secret," or "Top Secret."

The U. S. Government is absolved from any litigation which may ensue from the contractor's infringing on the foreign patent rights which may be involved.

REPORT DOCUMENTATION PAGE			Form Approved OMB No. 0704-0188	
Public reporting burden for this collection of information is estimated to average 1 hour per response, including the time for reviewing instructions, searching existing data sources, gathering and maintaining the data needed, and completing and reviewing the collection of information. Send comments regarding this burden estimate or any other aspect of this collection of information, including suggestions for reducing this burden, to Washington Headquarters Services, Directorate for Information Operations and Reports, 1215 Jefferson Davis Highway, Suite 1204, Arlington, VA 22202-4302, and to the Office of Management and Budget, Paperwork Reduction Project (0704-0188), Washington, DC 20503.				
1. AGENCY USE ONLY (Leave blank)	2. REPORT DATE MARCH 1950	3. REPORT TYPE AND DATES COVERED FINAL JANUARY - MARCH 1950		
4. TITLE AND SUBTITLE OPTICAL WORK ON UNUSUALLY LARGE GLASS PLATES: AN INTERFERENCE METHOD OF INVESTIGATING HIGH-QUALITY FLAT SURFACE.			5. FUNDING NUMBERS	
6. AUTHOR(S) THEODOR W. ZOBEL FERDINAND M. MIRUS				
7. PERFORMING ORGANIZATION NAME(S) AND ADDRESS(ES) AIRCRAFT LABORATORY ENGINEERING DIVISION (WIND TUNNEL BRANCH) AIR FORCE MATERIEL COMMAND WRIGHT-PATTERSON AFB, OH 45433			8. PERFORMING ORGANIZATION REPORT NUMBER	
9. SPONSORING/MONITORING AGENCY NAME(S) AND ADDRESS(ES) AIRCRAFT LABORATORY ENGINEERING DIVISION (WIND TUNNEL BRANCH) AIR FORCE MATERIEL COMMAND WRIGHT-PATTERSON AFB, OH 45433			10. SPONSORING/MONITORING AGENCY REPORT NUMBER AF-TR-5991	
11. SUPPLEMENTARY NOTES				
12a. DISTRIBUTION AVAILABILITY STATEMENT APPROVED FOR PUBLIC RELEASE; DISTRIBUTION UNLIMITED			12b. DISTRIBUTION CODE	
13. ABSTRACT (Maximum 200 words) THE PROBLEM OF DETERMINING QUANTITATIVELY THE EXACT SURFACE CONTOUR OF LARGE GLASS PLATES IS ESSENTIALLY A PROBLEM OF OBTAINING A LARGE AND ACCURATELY FLAT REFERENCE SURFACE ON WHICH TO BASE THE MEASUREMENTS. A MEASURING METHOD IS DESCRIBED WHICH MAY BE EMPLOYED TO OBTAIN THE CONTOUR MEASUREMENTS OF GLASS PLATES OF ANY PRACTICAL SIZE. A THIN LIQUID LAYER, FOR EXAMPLE, WATER, COVERS THE PLATE TO BE INVESTIGATED. THE LIQUID LAYER PROVIDES THE FLAT AND ALWAYS HORIZONTAL REFERENCE PLANE FROM WHICH QUANTITATIVE CONTOUR MEASUREMENTS MAY BE MADE. INTERFERENCE PHENOMENA - LINES OF CONSTANT DISTANCE FROM THE REFERENCE SURFACE - ARE PRODUCED DUE TO REFLECTIONS ON THE LIQUID LAYER AND THE PLATE SURFACES. TRUE SURFACE CONTOUR PICTURES MAY THEN BE TAKEN IN ONE OPERATION. QUANTITATIVE SURFACE MEASUREMENTS CAN BE CALCULATED FROM THE PICTURES BY EMPLOYING KNOWN LIGHT WAVE LENGTH.				
14. SUBJECT TERMS GLASS PLATES, INTERFERENCE PHENOMENA			15. NUMBER OF PAGES 15	
			16. PRICE CODE	
17. SECURITY CLASSIFICATION OF REPORT UNCLASSIFIED	18. SECURITY CLASSIFICATION OF THIS PAGE UNCLASSIFIED	19. SECURITY CLASSIFICATION OF ABSTRACT UNCLASSIFIED	20. LIMITATION OF ABSTRACT SAR	

AF TECHNICAL REPORT NO. 5991

March 1950

OPTICAL WORK
on
UNUSUALLY LARGE GLASS PLATES
An Interference Method of Investigating
High-Quality Flat Surfaces

Theodor W. Zobel
Ferdinand M. Mirus

United States Air Force
Air Materiel Command
Wright-Patterson Air Force Base, Dayton, Ohio

ABSTRACT

The problem of determining quantitatively the exact surface contour of large glass plates is essentially a problem of obtaining a large and accurately flat reference surface on which to base the measurements. Presently, a comparison surface of from 12 to 15 inches diameter represents the best that can be made accurately within reasonable cost. For many reasons, comparison plates of 36 inch diameter cannot be made at all.

A measuring method is described which may be employed to obtain the contour measurements of glass plates of any practical size. A thin liquid layer, for example, water, covers the plate to be investigated. The liquid layer provides the flat and always horizontal reference plane from which quantitative contour measurements may be made. Interference phenomena - lines of constant distance from the reference surface - are produced due to reflections on the liquid layer and the plate surfaces. True surface contour pictures may then be taken in one operation. Quantitative surface measurements can be calculated from the pictures by employing the known light wave length.

Many measurements and studies on 36 inch diameter, 1-1/4 inch thick, plates were made with particular reference to the flexibility and deformation as applicable to interferometer development.

PUBLICATION REVIEW

Manuscript Copy of this report has been reviewed and found satisfactory for publication.

FOR THE COMMANDING GENERAL:

Randall S. Teator LT Col
USAF
for JACK A. GIBBS
Colonel, USAF
Chief, Aircraft Laboratory
Engineering Division

FOREWORD

This report was initiated and prepared by the Wind Tunnel Branch, Aircraft Laboratory, Engineering Division, Air Materiel Command. The project was administered under Expenditure Order No. 903-1970, with Dr. Theodor W. Zobel and Mr. Ferdinand M. Mirus acting as project engineers.

TABLE OF CONTENTS

<u>Section</u>	<u>Page</u>
I - The Surface Accuracy As a Function of the Size of Plates	1
II - The Common Interference Method of Testing Glass Surfaces of Small Dimensions.	2
III - The Influence of the Flexibility on the Measuring and Surfacing Process	7
IV - A New Interference Method for Measuring Unusually Large Glass Surfaces.	10
V - The Flexibility of Glass Plates	25
VI - Optical Corrections by Deforming Reflecting Surfaces. .	32
VII - Summary	36
Bibliography.	37

LIST OF ILLUSTRATIONS

		Page No.
Figure 1	The Relationship Between Displacement and the Dimensions of a Plate	1
Figure 2	The Relationship Between the Number of Fringes and the Size of a Plate	2
Figure 3	Sketch to Determine the Radius of Curvature of a Plate Surface	3
Figure 4	Common Interference Method for Testing Plate Surfaces.	4
Figure 5	Lifting of the Comparison Plate to Determine the Kind of a Curved Surface.	5
Figure 6	Determination of the Curvature of the Plate Surface by Side Lifting of the Comparison Plate	6
Figure 7	The Sagging of a Plate in an Oblique Position	9
Figure 8	Measuring a Large Plate Surface Using a Small Comparison Plate of High Quality.	9
Figure 9	A Single Interference Picture of a Part of the Surface of a 36 Inch Diameter Plate, Produced by a 6 x 6 Inch Comparison Plate of Interference Quality	11
Figure 10	Mosaic of Single Interference Picture Compared with the Undisturbed Actual Surface Picture of the Entire Area	12
Figure 11	The Location of the Comparison Surface Relative to the Surface to be Measured in the Common Way Compared with the Conditions of the Liquid Interference Method.	15
Figure 12	The Principle of a Test Arrangement of the Liquid Interference Method.	16
Figure 13	The Physical Principle of the Liquid Interference Method	17

Figure 14	Interference Pattern Produced Between the Surface of a Glass Plate and the Surface of a Comparison Water Layer Covering the Plate	18
Figure 15	The Influence of the Thickness of the Water Layer, Above a 36 Inch Diameter Plate, 1-1/4 Inches Thick, on the Interference Pattern for Determining the Surface Quality.	20
Figure 16	Surface Profile of a 36 Inch Diameter Plate, 1-1/4 Inches Thick, Along Section A-B at Five Different Thicknesses of the Liquid Layer.	21
Figure 17	The Interference Pattern of the Surface of a Well Ground and Polished Glass Plate 36 Inches in Diameter, 1-1/4 Inches Thick, Produced by the Interference Liquid Method	22
Figure 18	Interference Picture of a Part of the 36 Inch Diameter Surface and Water Layer Obtained by Using a Concave Mirror 8.5 x 8.5 Inches.	23
Figure 19	Mosaic Strip of Small Interference Pictures Across One Section of the Surface Compared with the Total Surface Picture.	24
Figure 20	The Natural Form of a Vertical Unloaded Plate Assumes the Flatness of its Base as the Result of its Own Weight.	25
Figure 21	The Flexibility of a Well Ground and Polished Glass Plate, 36 Inches in Diameter, 1-1/4 Inches Thick, Under the Influence of its Own Weight, Demonstrated by the Interference Pattern on One Surface.	27
Figure 22	The Flexibility of a Glass Plate of 36 Inches in Diameter and 1-1/4 Inches Thick, Along Section A-B.	28
Figure 23	Temporary Change of the Surface of a Well Ground and Polished Glass Plate, 36 Inches in Diameter, 1-1/4 Inches Thick, after Removing a 3 Point Support and Handling the Plate. No Effect of Weight. Plate Floating in Mercury	29
Figure 24	The Actual Surface of a Well Ground and Polished Sample Plate of 36 Inches Diameter, 1-1/4 Inches Thick, Prepared as a Plate with Ring Shaped Pattern when Unloaded.	30

Figure 25	The Actual Surface Profile of a Well Ground and Polished Sample Plate 36 Inches in Diameter, 1-1/4 Inches Thick, Prepared as a Plate with Ring-Shaped Pattern When Unloaded.	31
Figure 26	The Actual Surface Profile of a Well Ground and Polished Sample Plate 36 Inches in Diameter, 1-1/4 Inches Thick, Prepared as a Plate with a Uniformly Curved Surface and a Larger Number of Rings in the Pattern than in Surface No. 1	31
Figure 27	Perspective Representation of the Actual Surface of a Well Ground and Polished Sample Plate, 36 Inches in Diameter, 1-1/4 Inches Thick.	32
Figure 28	The Influence of the Deformation on the Surface Shape of a Well Ground and Polished Glass Plate 36 Inches in Diameter, 1-1/4 Inches Thick.	34
Figure 29	The Deformation of a Well Ground and Polished Glass Plate 36 Inches in Diameter, 1-1/4 Inches Thick, by Only One Center Screw While Supported Between 12 Screws and Lock Screws Along the Periphery.	35
Figure 30	The Deformation of a Well Ground and Polished Glass Plate 36 Inches in Diameter, 1-1/4 Inches Thick, by Several Screws while Supported Between 12 Screws and Lock Screws Along the Periphery.	35

LIST OF SYMBOLS

r	radius of a plate
d	diameter of a plate
R	radius of curvature
f, h	displacements
l	length dimension
n	index of refraction
N	number of fringes
λ	wave length of light
$\lambda' = \frac{\lambda}{n_{\text{liquid}}}$	(for example for water $\lambda' = \frac{\lambda}{1.33}$)
p	specific load per unit area
γ	specific weight
g	specific gravity
E	modulus of elasticity
t	thickness of a plate, or of a water layer
α_i	interference angle - angle between two interfering light rays
b	width of interference fringes

INTRODUCTION

The problem of investigating glass surfaces of unusually large dimensions and of highest possible quality is important in interferometer development. Interferometers of satisfactory performance can be built only if reflecting surfaces of an extremely high degree of flatness are available. Expressed in terms of the wave length of the light used, the limit of inaccuracy of flatness should be within a fraction of a wave length distributed uniformly over the entire area to be measured.

For instruments of small size, with optical components limited to about 10 inches diameter, common interference methods for investigating the surfaces are satisfactory. The comparison plates should be of very high and known quality, and at least as large as the plates to be investigated. The optical components can be made sufficiently thick so that the flexibility can be neglected.

New and difficult measuring problems arise if an entire quantitative picture of the surface is required in one step. This is necessary to judge the surface quality if the flexibility has to be considered. Essentially the problem of flexibility influences the surfacing of glass plates, if large, thin plates with a very high flexibility are considered.

SECTION I

THE SURFACE ACCURACY AS A FUNCTION OF THE SIZE OF PLATES

Since the limit of the total amount of inaccuracy should have the same absolute value for large interference plates as for small ones, it can be understood that the quality of the surface of large plates must be much higher than for small ones.

The relationship between the displacement "h" and the size of the plate can be seen in Figure 1.

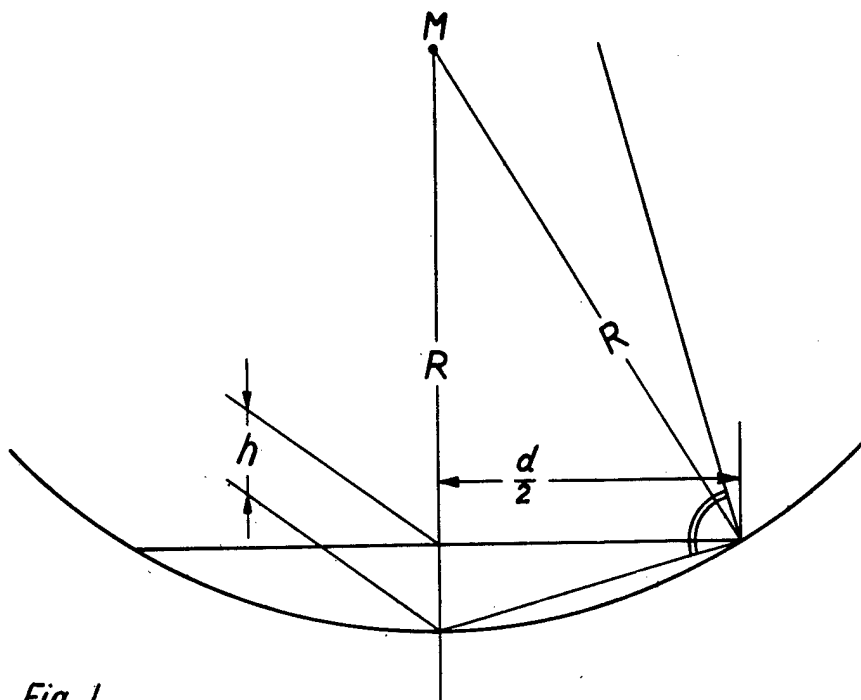

Fig. 1

$$\left(\frac{d}{2}\right)^2 = 2hR - h^2$$

Since $h \ll R$, for the case of glass plates, it may be stated to very close approximation that "h" varies as the square of the diameter, at any constant value of R.

$$2hR \approx \left(\frac{d}{2}\right)^2, \text{ therefore } h \approx \frac{1}{8R} \cdot d^2 = \text{const. } d^2 \text{ (See Figure 2)}$$

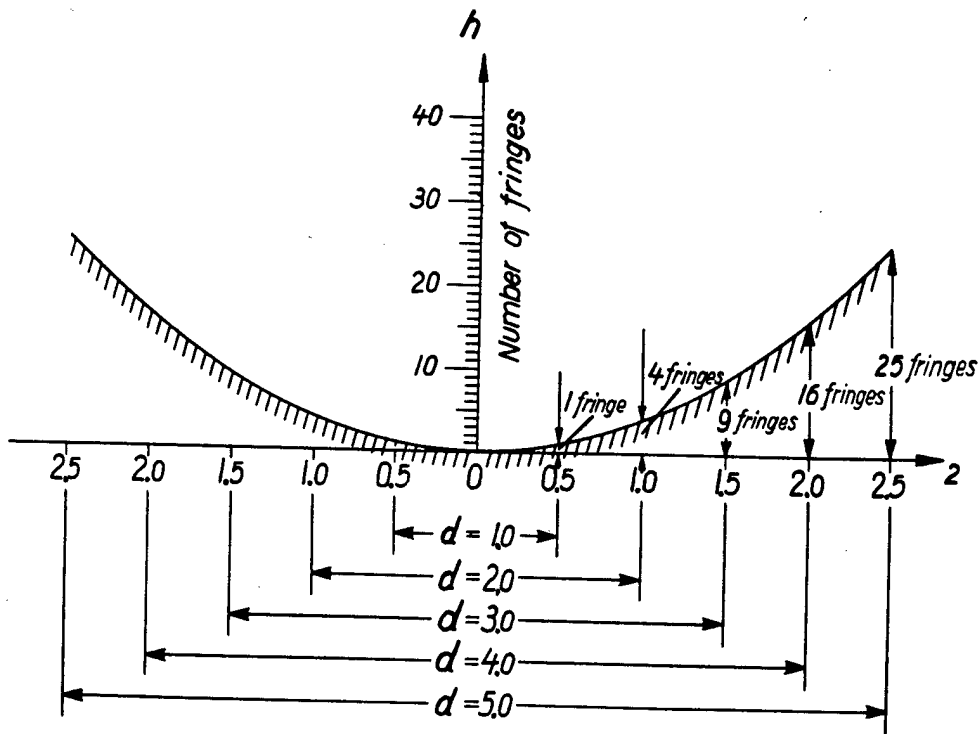

Fig. 2

This relationship is illustrated in Figure 2 which shows that doubling the diameter of the plate would result in four times the number of ring shaped interference fringes, tripling, in nine times as many, etc.

Because of this relationship the difficulties for both surfacing and testing increase tremendously with increasing size of the glass plates.

SECTION II

THE COMMON INTERFERENCE METHOD OF TESTING GLASS SURFACES OF SMALL DIMENSIONS

An accurate way to determine surface qualities is the production of Newton's fringes within the airtlayer between an exact and known comparison surface and the surface to be measured.

In Figure 3, "A" is the flat comparison surface and "B", the surface to be investigated. It is assumed that the surface to be tested

is spherical. After the relations shown in the foregoing section, the deviation "h" from the absolute flatness is:

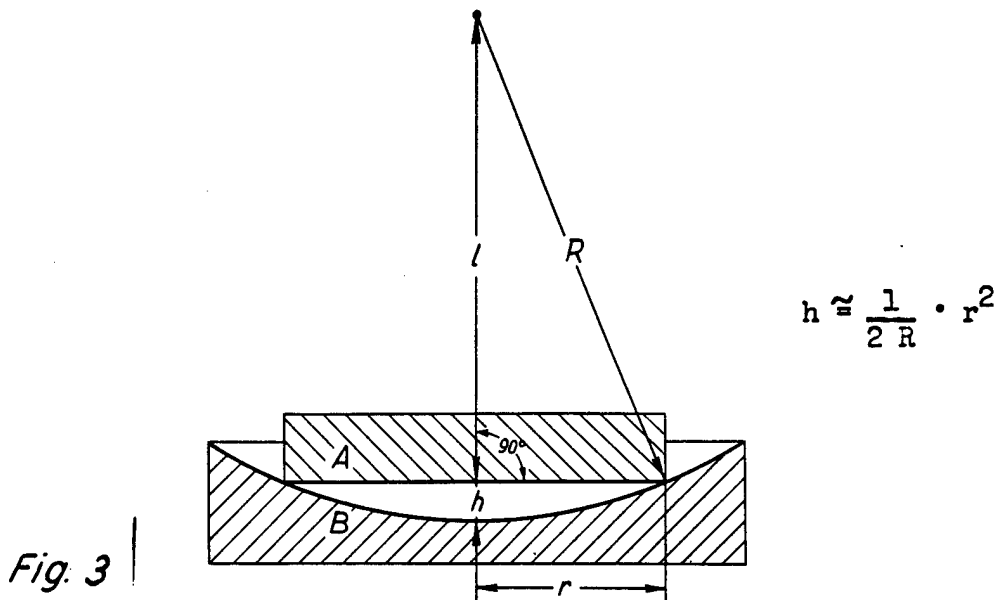

This deviation from flatness of the plate surface can be measured as $h = N \cdot \lambda / 2$, where N is the number of fringes. Then the radius of the curvature of the surface to be investigated can be calculated as:

$$R \approx \frac{r^2}{2h} = \frac{r^2}{N \cdot \lambda}$$

Figure 4 shows a test arrangement based on the idea described above for investigating glass surfaces. The light coming from a monochromatic light source is used for the measuring process as an approximated parallel light beam. A lens system produces a sharp interference picture showing the contour of the surface being tested on a screen or in a camera.

The interference fringes are produced by single light rays split or divided into two components; one component is reflected from the lower surface of plate 5, and the other from the upper surface of plate 6. The centers of the dark regions observed represent those positions where the phase difference between the components is π radians. This means positions where the effective optical path difference is one-half wave length ($\lambda/2$) or odd multiples of half wave lengths ($\lambda/2, 3\lambda/2, 5\lambda/2, 7\lambda/2, \dots$ etc.) after considering reflection from plate 6 is accompanied by a phase reversal. The distance from one fringe to the next adjacent fringe corresponds to a change of one-half wave length in the distance between the reflecting surfaces 5 and 6, because the light reflected from surface 6 traverses this gap twice.

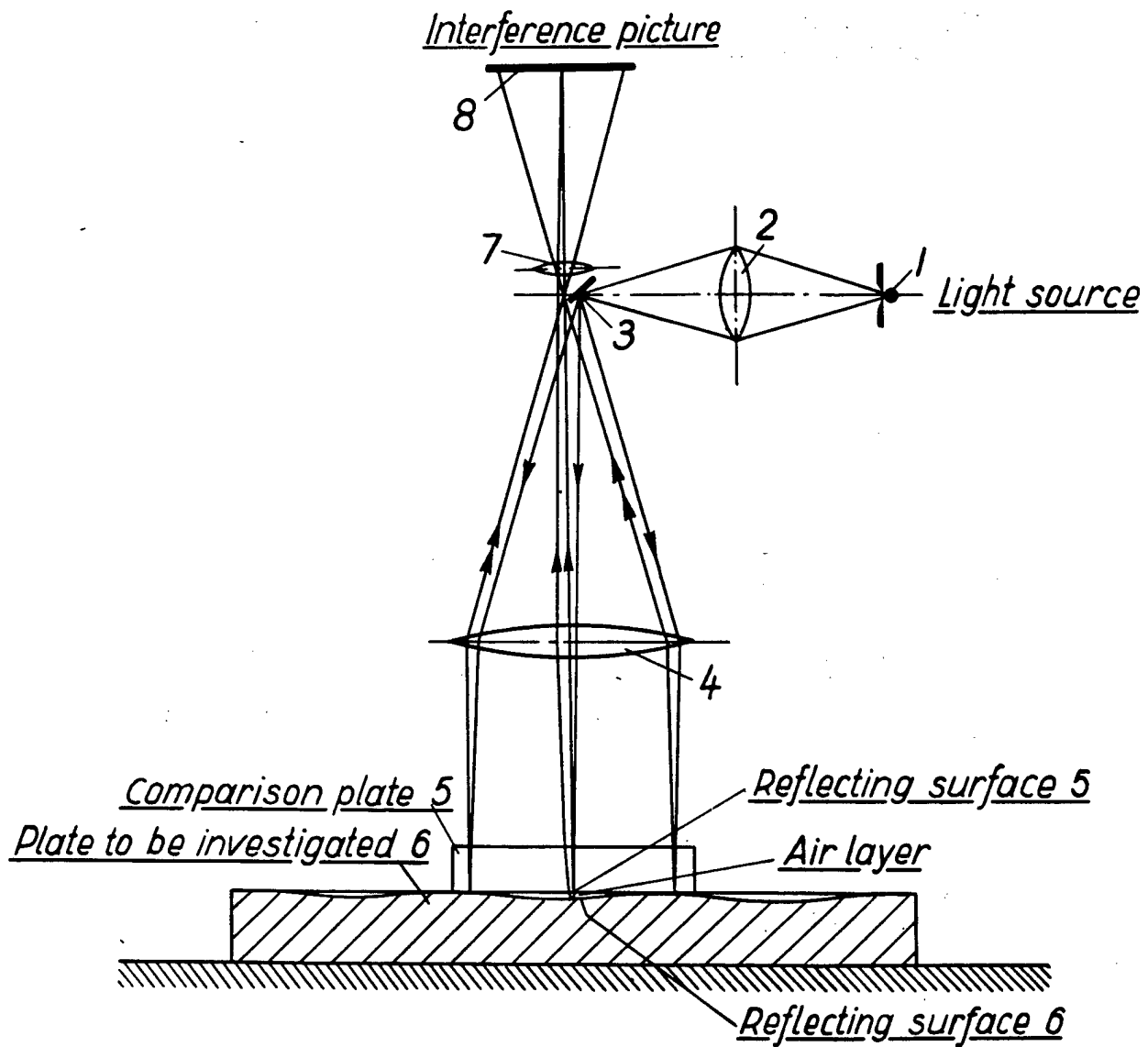
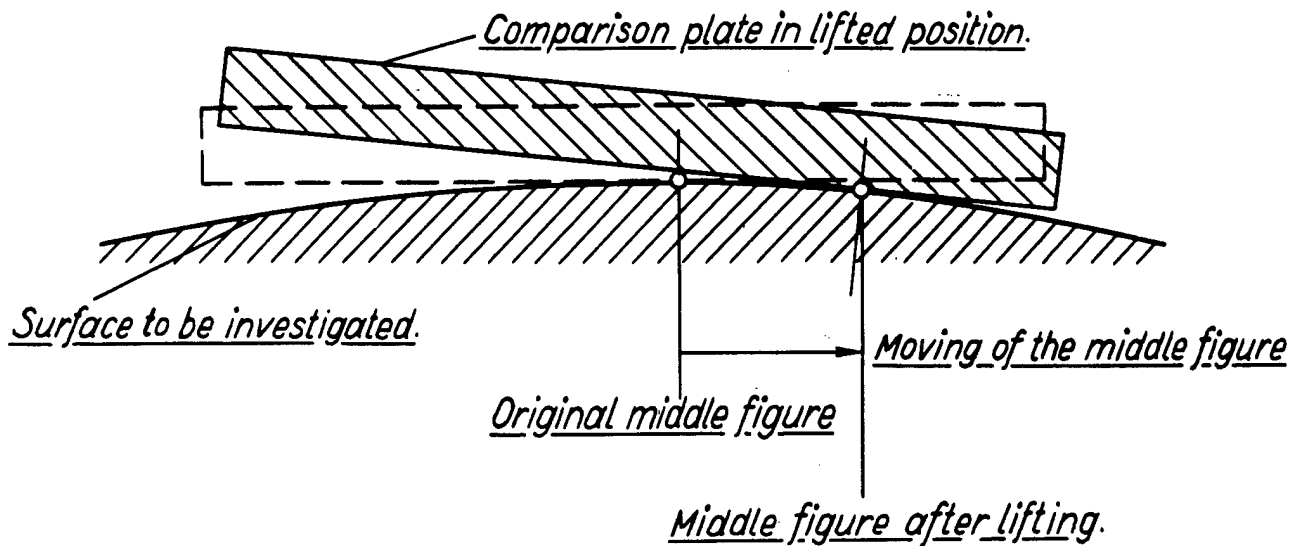

Fig. 4 Common interference method for testing plate surfaces.

(a) Convex surface



(b) Concave surface

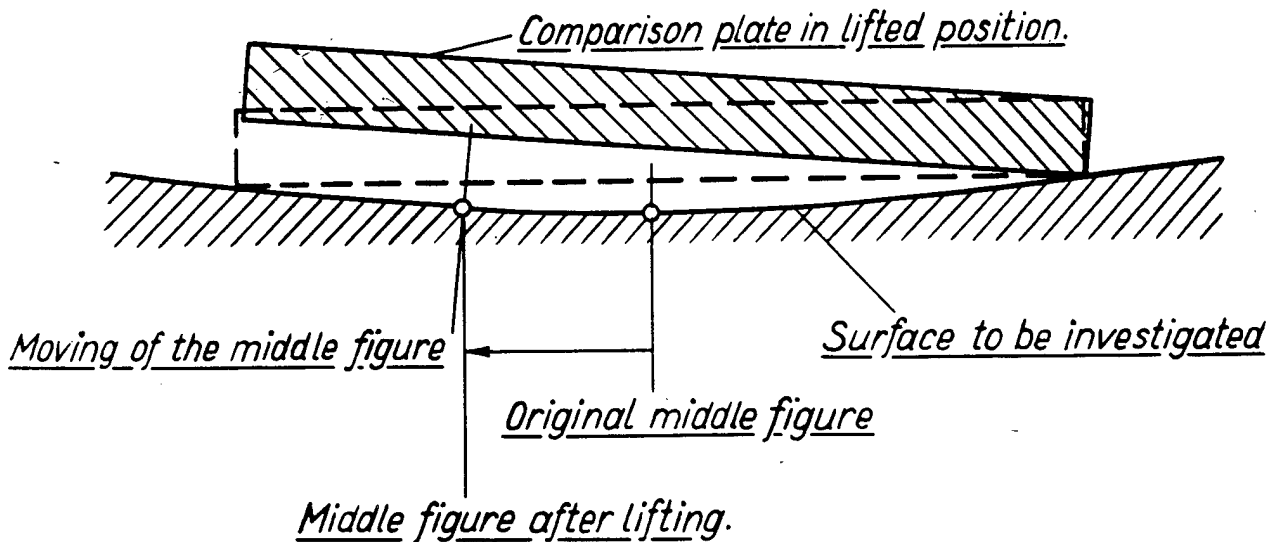
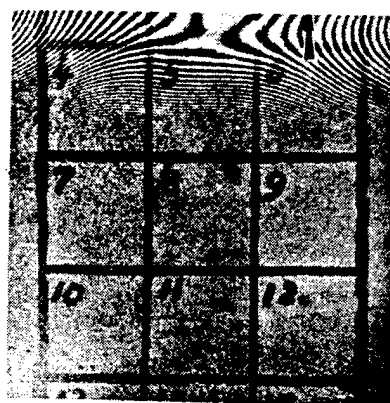
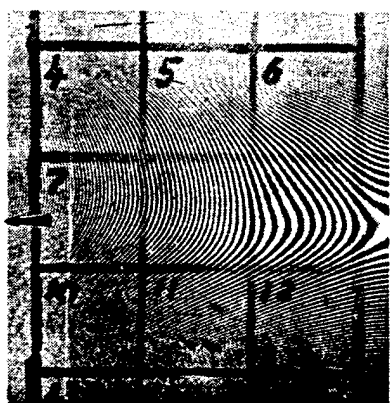

Fig. 5. Lifting of the comparison plate to determine the kind of a curved surface.



Concave



Convex

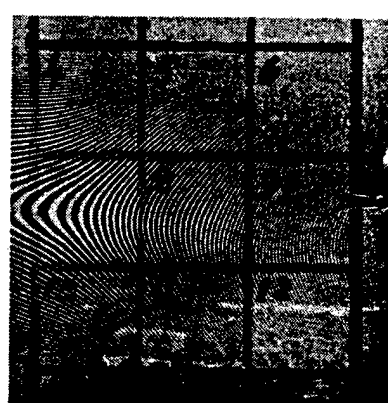
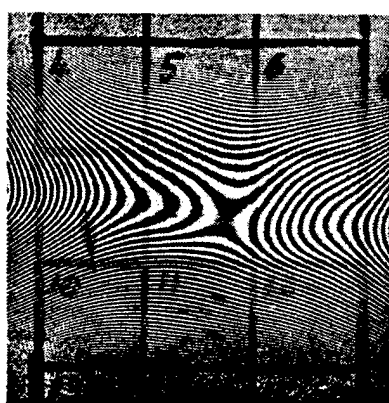

Convex

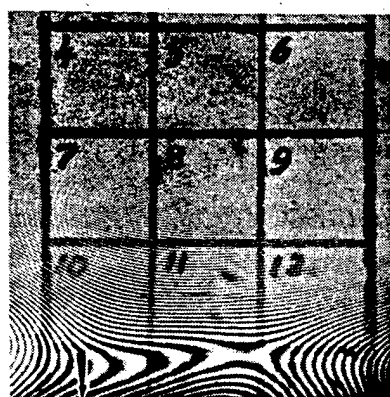

Concave

Fig. 6. Determination of the curvature of the plate surface by side lifting of the comparison plate (see the arrows)

The location and form of the fringes depend upon the relative inclination of the surfaces. The interference pattern therefore shows a picture of the surface contour represented by lines of constant distance from the comparison surface. This method works well but requires a comparison plate as large or almost as large as the plate to be investigated.

The sign of the curvature (convex or concave) can be determined by lifting the comparison plate either parallel with its original position or at one side. (See Figures 5 and 6.) The resultant movement of the so-called "middle figure" can be used to determine the surface shape. The middle figure is the characteristic pattern which appears at places where the tangents on both surfaces are parallel. Its location depends upon the inclination of the comparison plate. (See Figures 5a, b.)

A comparison plate, if it is to serve for large plates, should be as large as the plate to be tested, should have negligible flexibility, and should have optical perfection. A comparison plate of such large dimensions is impractical.

SECTION III

THE INFLUENCE OF THE FLEXIBILITY ON THE MEASURING AND SURFACING PROCESS

The measuring problem changes if the flexibility of the comparison plate and the plate to be investigated can no longer be neglected. Such a problem arises, for example, in using glass plates 36 inches in diameter and 1-1/4 inches thick.

The reason for proposing that such thin plates be used for large interferometers is that a wider selection of glass sheets of this thickness, and of a sufficiently high optical quality can be found which are relatively inexpensive and available in a wide variety of sizes.

It is almost impossible to produce large sheets of thick optical glass of high quality with a ratio of thickness to diameter of about 1:10 up to 1:5. The flexibility of such thick sheets still could not be neglected. The deflection of a horizontal glass plate caused by its own weight can be calculated as follows, (Reference 2):

$$f = 0.696 \frac{p \cdot (d/2)^4}{E \cdot t^3} = f_{\text{horizontal}}$$

The specific load is given by:

$$p = W/A = \frac{t \cdot \left(\frac{d^2 \pi}{4}\right) \gamma}{\left(\frac{d^2 \pi}{4}\right)} = \gamma \cdot t$$

For the 45° position, as shown in Figure 7, the effective weight, W , causing the deflection, f , is reduced to $W/\sqrt{2}$. Therefore:

$$P_{\text{eff}} = \frac{\gamma \cdot t}{\sqrt{2}} = \frac{p}{\sqrt{2}}$$

has to be introduced in the formula above so that it reads:

$$f_{45^\circ} = 0.696 \cdot \frac{p \cdot (d/2)^4}{\sqrt{2} \cdot E \cdot t^3} = 0.696 \cdot \frac{\gamma \cdot t \cdot (d/2)^4}{\sqrt{2} \cdot E \cdot t^3} = \frac{f_{\text{horizontal}}}{\sqrt{2}}$$

As shown in Figure 22, the deviation of a glass plate 36 inches in diameter, 1-1/4 inches thick, was found as:

$$f_{\text{horizontal}} \approx 30 \lambda \text{ or } 60 \text{ fringes}$$

$$f_{45^\circ} = \frac{f_{\text{horizontal}}}{\sqrt{2}} = 21.2 \lambda \text{ or } 42.4 \text{ fringes}$$

Then a glass plate of 3.6 inches thickness as shown in Figure 7 would still show a deflection of:

$$f_{45^\circ} = \left(\frac{1.25}{3.6}\right)^2 \cdot 21.2 \lambda = 2.54 \lambda \text{ or } 5.08 \text{ fringes}$$

(1:10)

Even with a thickness to diameter ratio of 1:5, the deflection would still exceed by far the requirements of interference quality:

$$f_{45^\circ} = \left(\frac{1.25}{7.2}\right)^2 \cdot 21.2 \lambda = 0.635 \lambda \text{ or } 1.27 \text{ fringes}$$

(1:5)

This means that the flexibility should be considered in the grinding and polishing process. If the flexibility problem can be solved at all, in principle, thin plates present a better possibility of obtaining high quality optical glass in large sheets; they would be less expensive and more suitable for correcting purposes.

The measuring problem is illustrated by an extreme example. (See Figure 8.)

The plate to be investigated is 6 times larger in diameter than the comparison plate. As far as the center part of the system is concerned, the measuring system works accurately because of the relationship of all

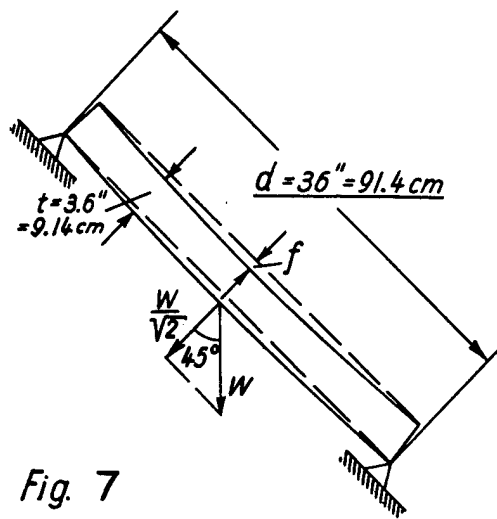

Fig. 7

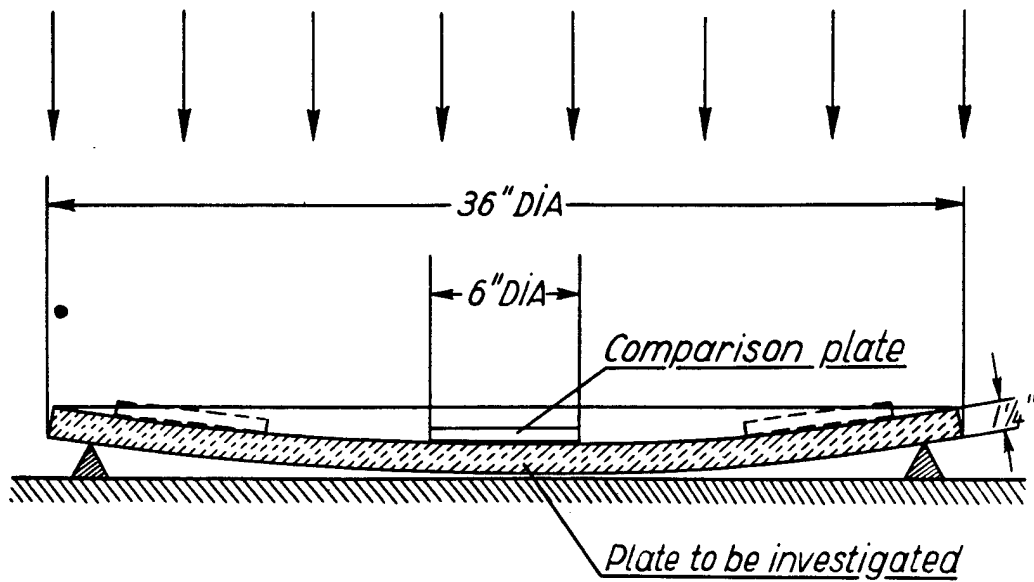

Fig. 8 Measuring a large plate surface using a small comparison plate of high quality.

components to the comparison surface. This relationship is lost, however, if the small plate is moved over the surface of the large plate.

Since it is probable that the surface of the plate to be tested is not uniformly curved, but irregular, in every position the small plate adjusts itself to the large plate. A relationship no longer exists between the surface to be investigated and an exactly defined position of the comparison surface. If a small comparison plate is moved over a large plate, the small single interference pictures, taken in each position, have no known relationship to each other and to a definite position of the comparison surface.

The measuring accuracy achieved on the center area with the small comparison plate could be approximated, in principle, with a large comparison plate of proven quality with negligible flexibility and refraction effects. Such a comparison plate would be an extremely expensive measuring tool if it could be made at all. It could not be used practically because its weight would change entirely the surface conditions of the plate to be investigated. However, even neglecting the weight of the comparison plate, the system does not work correctly, since no defined position of the comparison plate exists in every location.

This fact is illustrated in Figures 9 and 10 where it is shown how the mosaic of single small 6" x 6" areas of the 36 inch diameter plate differs from the actual entire surface picture. (The actual surface picture is obtained by an exact method which is described in a later section.)

From these facts it is apparent that exact interference measurements on large plate surfaces can be made in one step only if a comparison surface of the highest possible degree of flatness is available, which is as large as the surface to be investigated, and for which the position is defined. Such a position could be, for instance, the horizontal position.

SECTION IV

A NEW INTERFERENCE METHOD FOR MEASURING UNUSUALLY LARGE GLASS SURFACES

As far as the quality of a surface is concerned, a liquid layer with small viscosity is almost perfect. Even if the area is unusually large, the influences of vibrations and temperature changes in the measuring room can be controlled. Undisturbed liquid layers can be assumed as practically flat, except for the uniform curvature of the earth itself which is calculable and negligibly small.

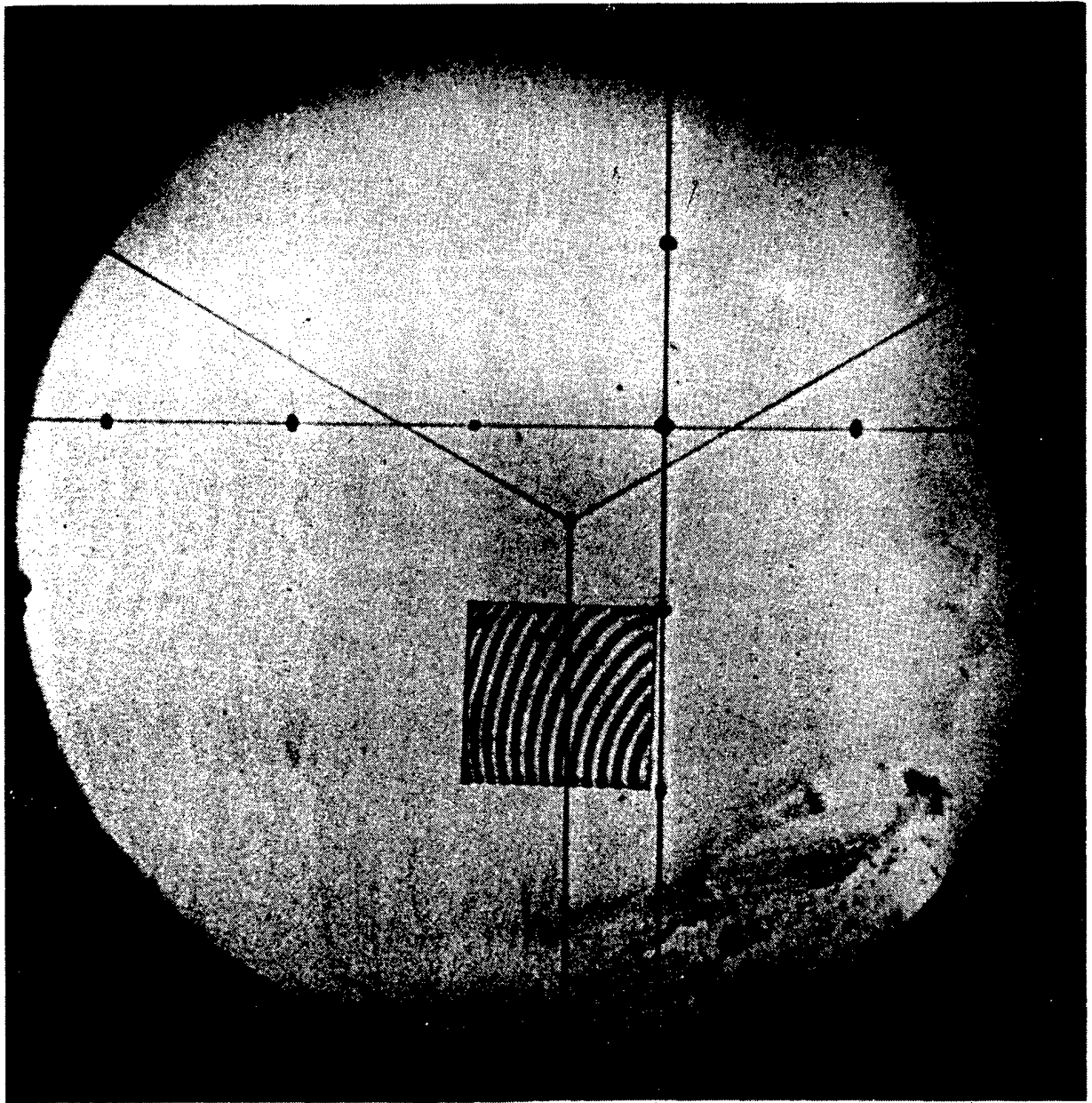

Fig. 9 A single interference picture of a part of the surface of a 36 inch diameter plate, produced by a 6x6 inch comparison plate of interference quality.

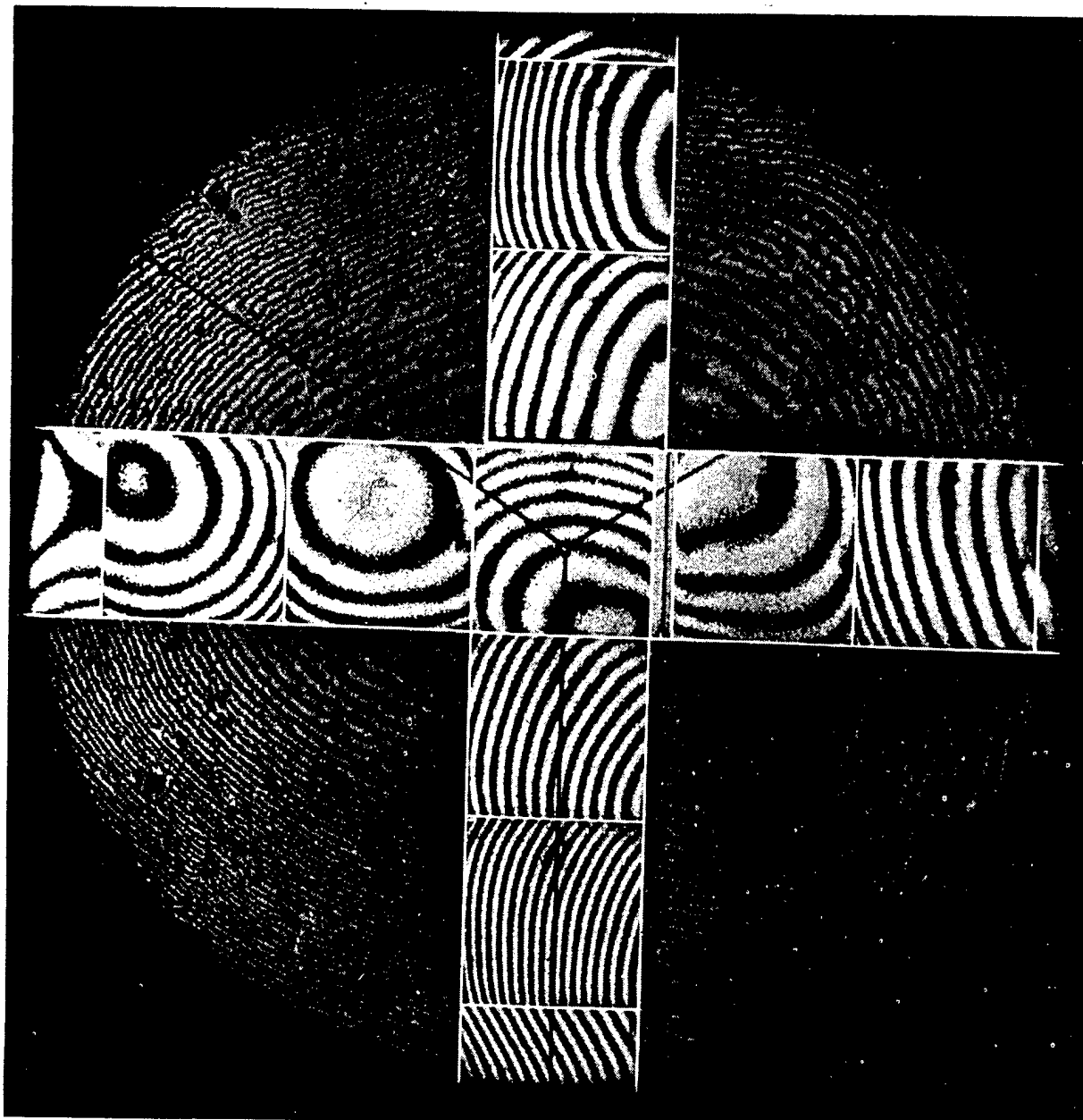

Fig. 10 Mosaic of single interference pictures compared with the undisturbed actual surface picture of the entire area.

If desired, the influence of the curvature of the earth can be taken into account, and the amount of the correction would be constant. The deviation from absolute flatness can be calculated as:

$$h = \frac{r^2}{2R} \quad (\text{See Section II})$$

If the plate with 36 inches diameter should be covered with water, for example, the data are:

$r \approx 0.5 \text{ m}$, the radius of the plate to be tested

$R \approx 7 \cdot 10^6 \text{ m}$, the radius of the earth

$$h \approx \frac{0.5^2 \text{ m}^2}{14 \cdot 10^6 \text{ m}} = 1.7 \cdot 10^{-8} \text{ m} \quad \text{or} \quad h \approx 1.7 \cdot 10^{-5} \text{ mm}$$

With a wave-length $\lambda = 0.0005461 \text{ mm}$, which corresponds to the green mercury line, the effective wave-length within the water layer becomes:

$$\lambda' = \frac{\lambda}{n_{\text{water}}} = \frac{0.000,546,1}{1.33} = 0.000,41 \text{ mm} \quad \text{and} \quad h = \frac{0.000,017,85}{0.000,41} \lambda' = \frac{1}{23.0} \lambda'$$

Therefore, the deviation from flatness because of the curvature of the earth is:

$$h \approx \frac{1}{23} \lambda'$$

corresponding to $\frac{1}{11.5}$ fringe as a constant

value uniformly distributed over the entire area of the surface.

Other important facts are that the liquid surface is not only flat but also horizontal. For this reason absolute measurements can be made because of the constant and known position of the comparison surface.

The liquid layer can be very thin so that its weight is negligible. Also, the optical density is uniform, which means that the refraction index within the liquid layer is constant.

Figure 11 shows the measuring method described in the foregoing section, compared with the new more exact method using a liquid as the comparison surface. It can be seen that even for selected small area tests, a true surface contour picture can be obtained by the liquid method because of the constant conditions of the liquid layer.

Figure 12 illustrates the principle of the new test arrangement as it has been used. The optical arrangement realizes a coincidence method. The approximately parallel light beam traverses the water layer to the glass plate, and the interference phenomena are produced by light which is reflected at the liquid and the glass surfaces. The liquid layer is used as the comparison plate. The appearance of the interference phenomena can be changed by changing the position of the plate to be tested relative to the liquid layer by means of a three point adjusting system.

As shown in Figure 12, the plate to be tested was lying on a ring in order to measure the real flexibility of the plate. A rubber ring (10) sealed the plate against the tray so that no water was under the plate and, therefore, the plate was loaded only by its own weight. The weight of the very thin liquid layer above the plate, which was uniformly distributed over the entire plate surface, was negligible. If the surface of the plate was uniformly curved and the plate adjusted for parallelism of the tangents at the plate center and the comparison water level, a pure ring shaped pattern would appear.

Figure 13 illustrates the working process of the Liquid-Interference method when a ring shaped pattern is produced by the superposition of plane wave fronts reflected from the water level, and spherically curved wave fronts formed by the reflection from the concave surface of the plate to be tested. The angle between two interfering light rays is given by the relations:

$$\sin \frac{\alpha_i}{2} \approx \frac{\lambda'/2}{b}; \quad \sin \frac{\Delta\alpha_i}{2} \approx \frac{b}{R} \quad \text{See Figure 13}$$

The formulas above are valid only as long as the slightly curved wave front reflected on the surface to be investigated can be assumed to be approximately plane over each width of fringe. Since the wave length of the light within the water layer is known as $\lambda' = \lambda/1.33$ and the fringe width can be measured on the interference picture, the angle α_i can be calculated. A horizontal flat plate would correspond with $\alpha_i = 0$; $R = \infty$ and $b = \infty$, and no interference fringe would appear in the field. Given an adjustment for $\alpha_i \neq 0$, the perfect plate would show parallel and straight interference fringes.

Figure 14 represents a typical interference pattern produced by a water layer above a glass plate. The surface condition of a curved area is picked out of a large plate surface. The quantitative picture shows the interference lines as lines of constant distance from the water level. The distance, b , between the single fringes corresponds to a difference in height of half a wave length, $\lambda/2$, of the light within water. The light used for the picture was the green mercury line with $\lambda = 5461\text{\AA}$ (Angstroem units, $1\text{\AA} = 10^{-7}\text{mm}$).

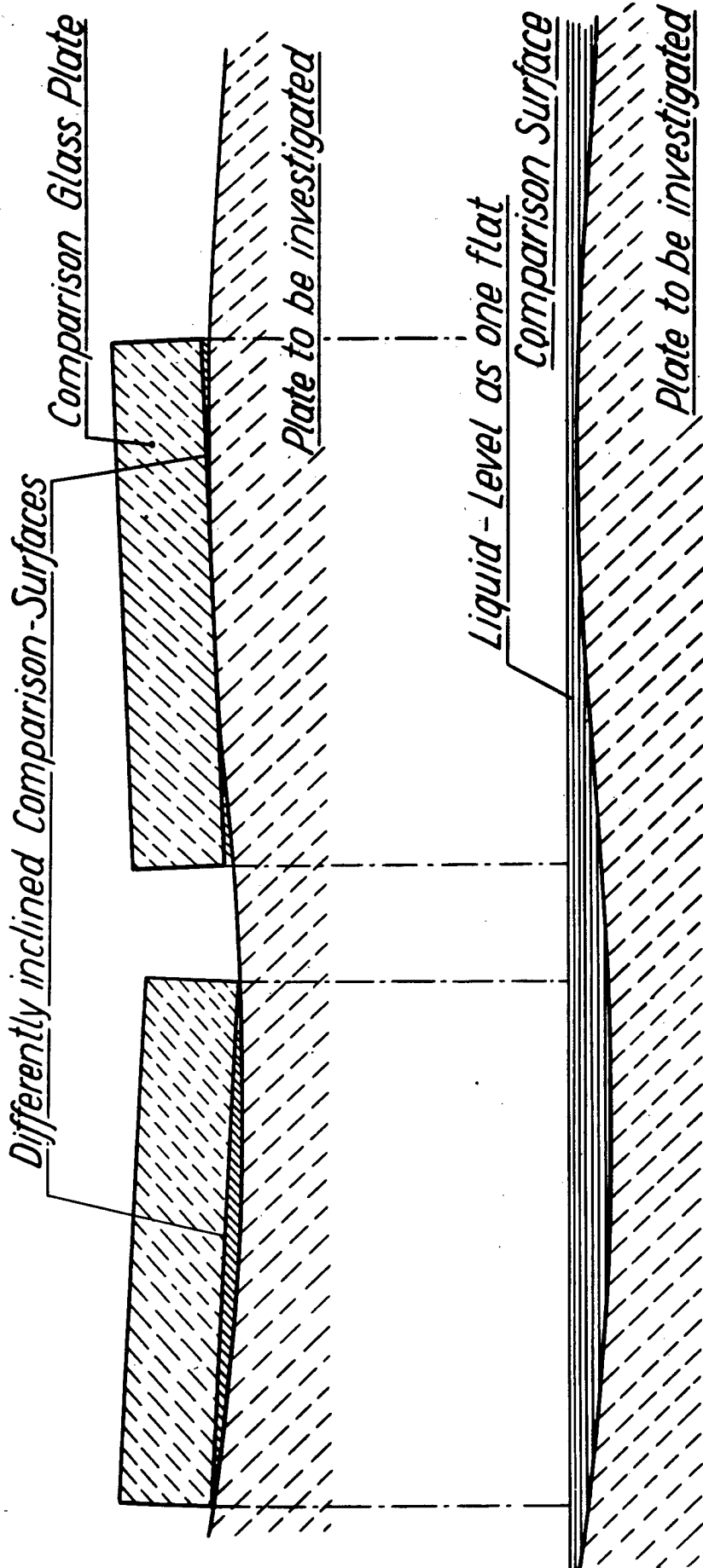

Fig. 11 The location of the comparison surface relative to the surface to be measured in the common way compared with the conditions of the liquid interference method.

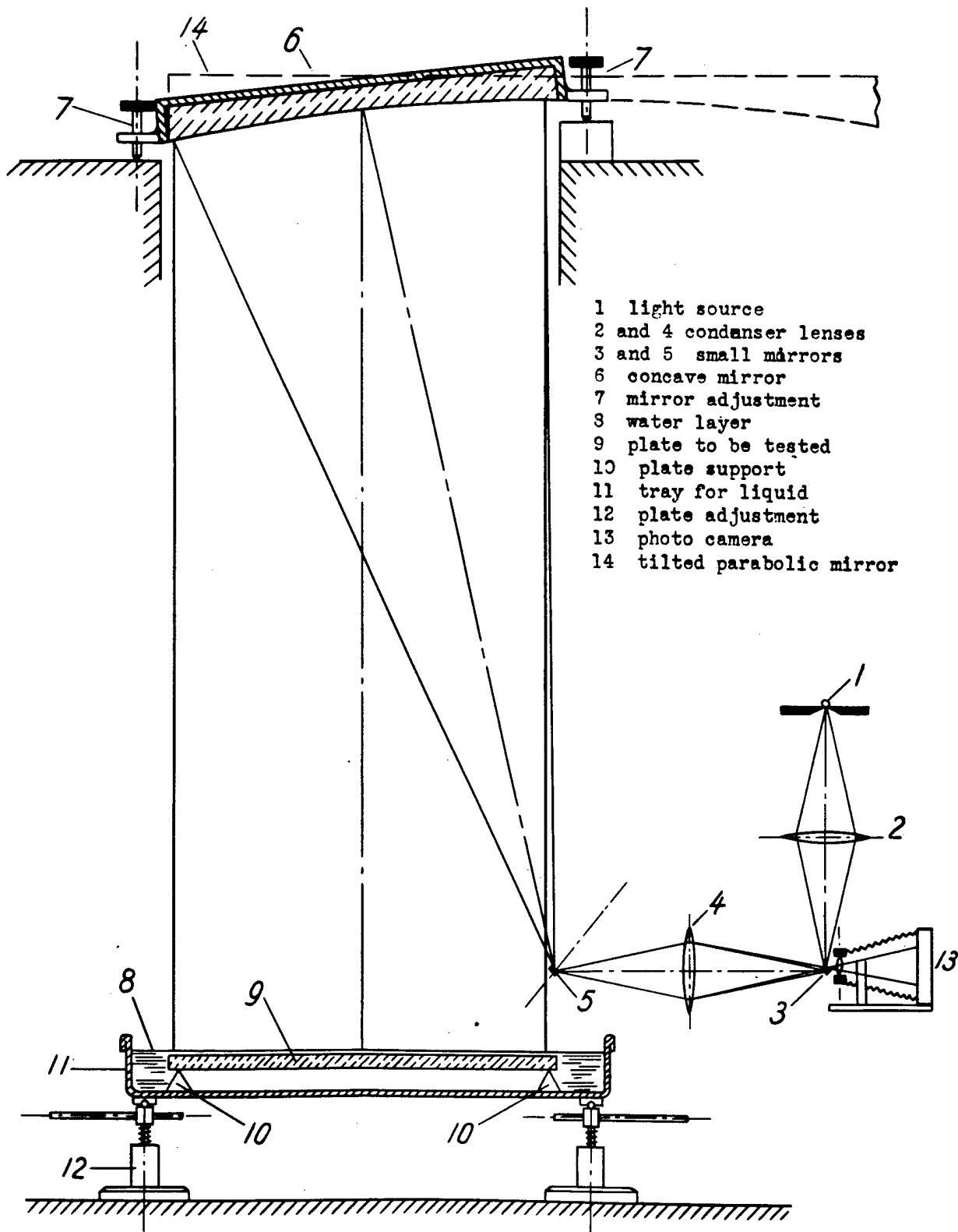

Fig. 12 The principle of a test arrangement of the liquid interference method.

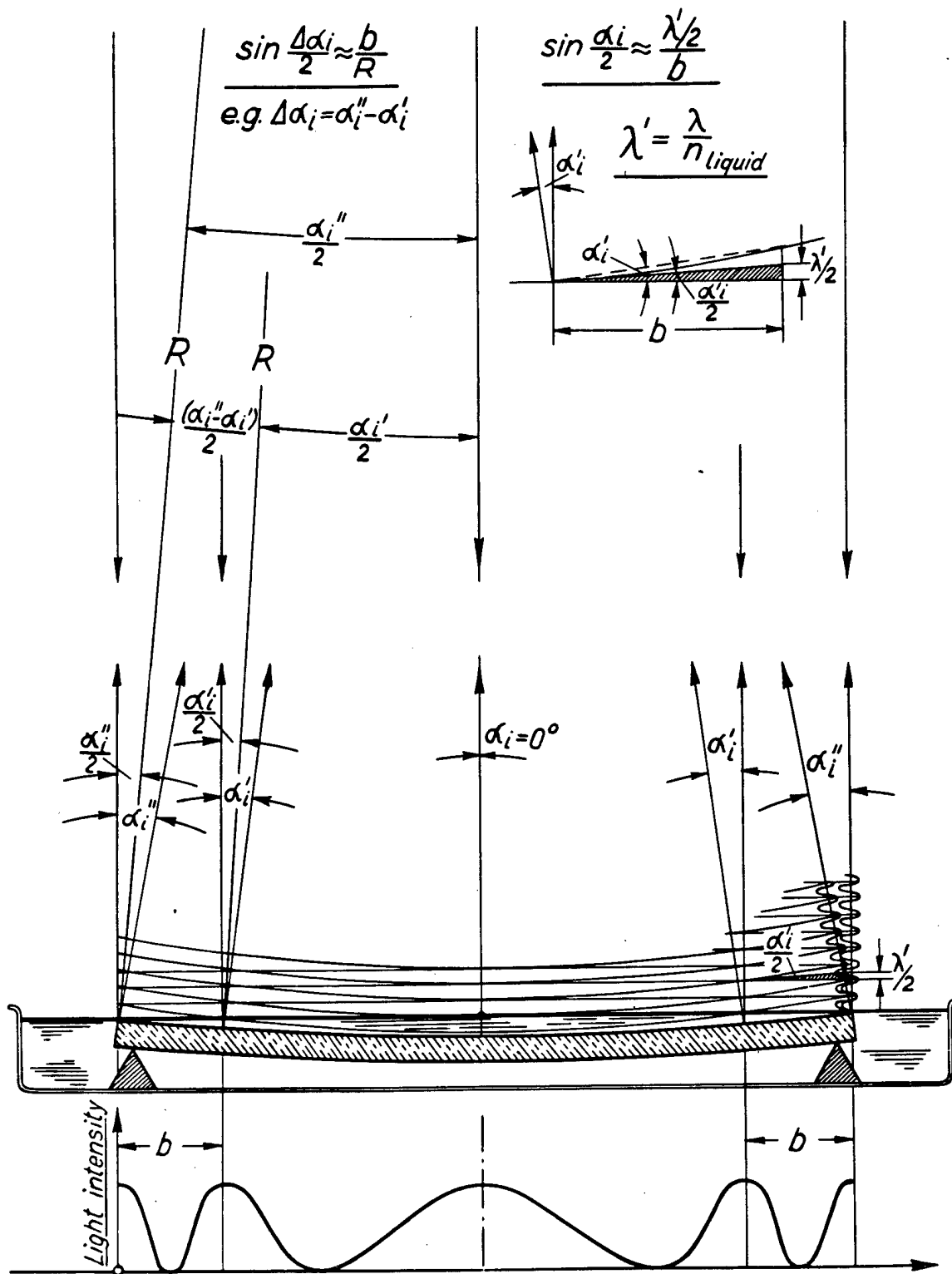

Fig.13 The physical principle of the Liquid Interference Method.

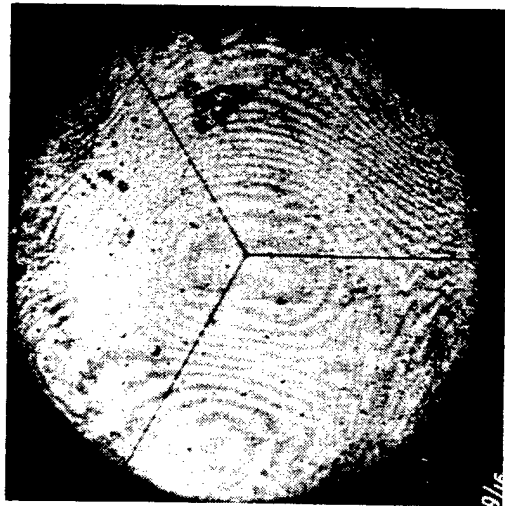

Fig. 14 Interference pattern produced between the surface of a glass plate and the surface of a comparison water layer covering the plate.

The little spots in the picture are small particles of dust floating on the water surface which do not disturb the characteristic interference picture.

This liquid method is especially suitable for investigating unusually large plate surfaces in order to determine the flexibility of plates and to study the deformation of plates for making optical corrections. For high quality measurements, the influence of vibrations on the liquid must be considered as well as the influence of temperature changes. However, even under unfavorable circumstances, the method has given some consistent results. One example is shown in Figure 15 of investigations on a 36 inch plate. The entire building was subjected to very noticeable vibrations because of construction work being done on the foundation. Five different thicknesses of water layer were used to determine their effect on the surface picture of the 36 inch diameter plate. The thickness was varied between 3.0 mm and 0.98 mm, measured in two different ways with an accuracy of ± 0.01 mm. In the handling process, very small inclinations of the plate, relative to the defined horizontal position of the water layer, could not be avoided. This can be seen by the location and form of the middle figure corresponding with the Y-shaped orientation system in each picture. The photographs show almost the entire area of the 36 inch diameter plate. Despite unfavorable influences, the individual pictures for the different water layer thicknesses look similar. The evaluation of these pictures through one section, A-B, is represented in the diagrams in Figure 16. In the lower part of the figure, the individual curves for the section A-B through the surface are shown. These were corrected for the shift of the entire curves relative to the horizontal comparison base. The superposition of all five curves in the upper part of Figure 16 shows a good agreement with the results of the single measurements.

The liquid method will still work reliably without a concave mirror as large as the surface to be investigated. An actual surface picture may be obtained by moving a smaller concave mirror over the surface and then placing together the individual surface pictures obtained. Figure 17 shows the surface picture of the entire area of a 36 inch diameter plate using a concave mirror of the same size. Figure 18 shows the picture of a small part of the area using a small concave mirror for the measuring system in one position. Figure 19 illustrates how the mosaic of a number of adjacent small areas appear superimposed on the original full picture by moving the small mirror across the plate. However, it is much easier to work with a full size mirror arrangement where the entire surface picture can be taken in one step.



$d = 3.00 \text{ mm}$

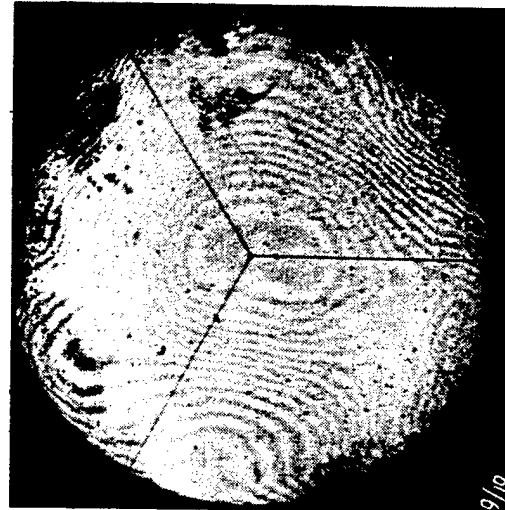

$d = 2.51 \text{ mm}$



$d = 2.00 \text{ mm}$



$d = 1.48 \text{ mm}$



$d = 0.98 \text{ mm}$

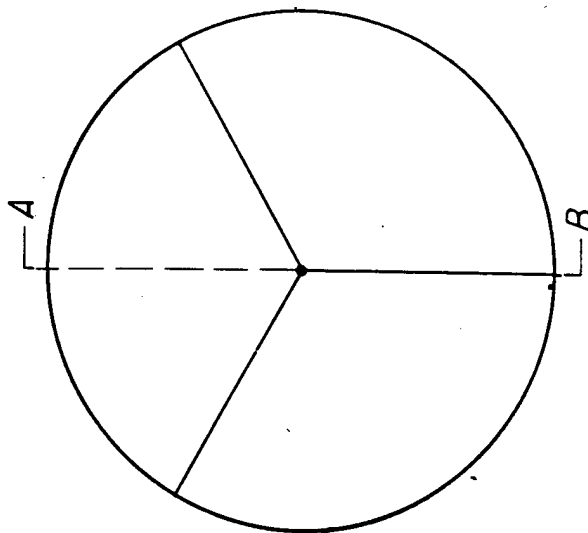

Fig. 15 The influence of the thickness of the water layer above a 36 inch diameter plate, 1/4 inches thick on the interference pattern for determining the surface quality.

Superposition

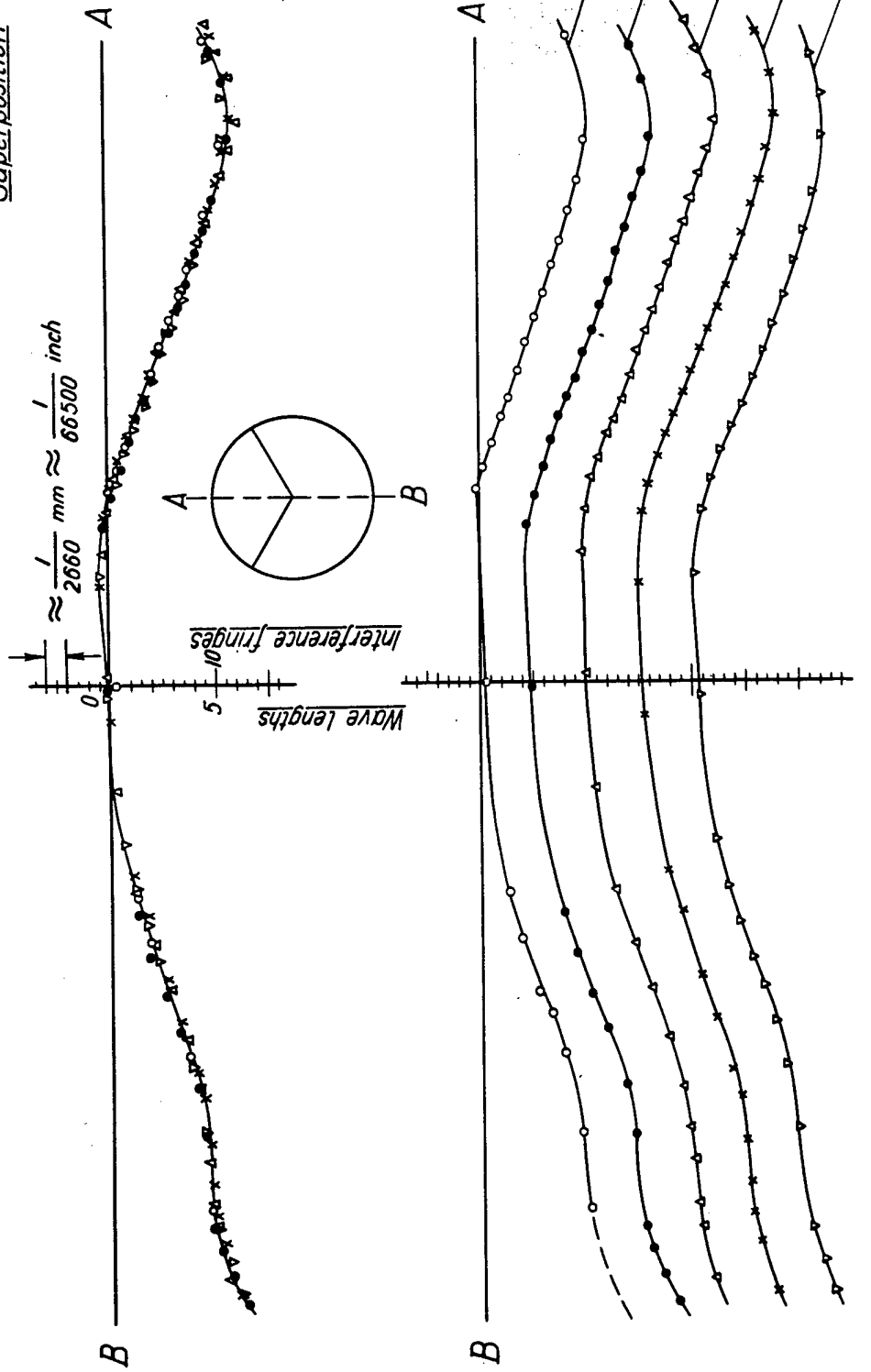

Fig. 16. Surface profile of a 36 inch diameter plate, 1/4 inches thick, along section A-B at 5 different thicknesses of the liquid layer. (Angle-correction for the same average position of the plate is made)



Fig.17 The interference pattern of the surface of a well ground and polished glass plate 36 inches in diameter, 1/4 inches thick, produced by the interference liquid method.

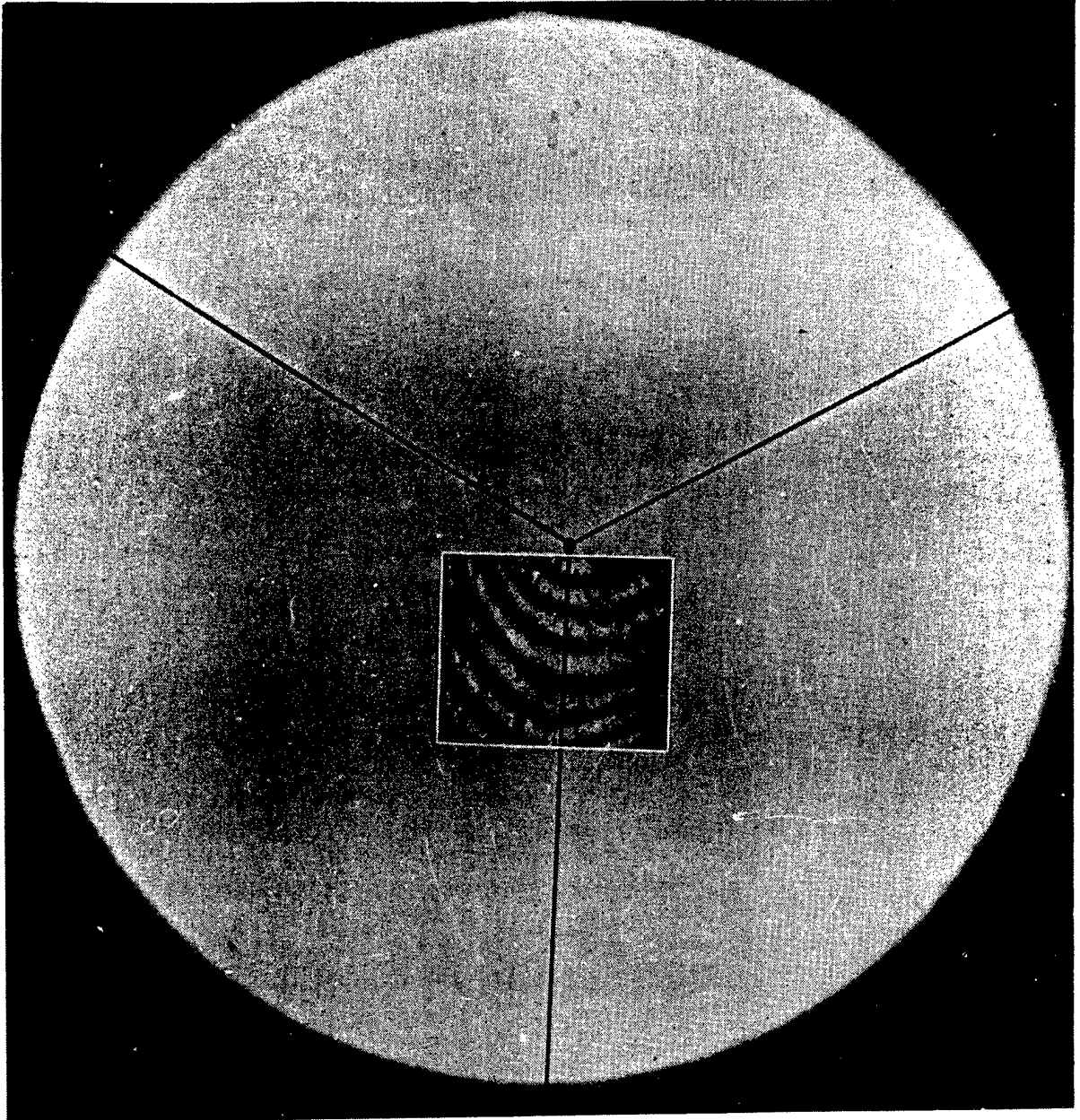

Fig. 18 Interference picture of a part of the 36 inch diameter surface and water layer obtained by using a concave mirror 8.5 x 8.5 inches.



Fig.19. Mosaic strip of small interference pictures across one section of the large surface compared with the total surface picture (Compare with Fig.10.)

SECTION V

THE FLEXIBILITY OF GLASS PLATES

In the problem of building interferometers of unusually large dimensions, the flexibility of the glass plates is the most important and difficult property to be controlled. Because of their flexibility, glass plates become deformed in every position by their own weight. The deformation caused by the weight, for instance, can be expressed by the deflection of plates in a horizontal position supported around the border. The displacement of the center is then given by:

$$f = 0.696 \cdot \frac{p \cdot r^4}{E \cdot t^3} = 0.696 \cdot \frac{(\gamma \cdot t) \cdot r^4}{E \cdot t^3} = 0.696 \cdot \frac{\gamma \cdot r^4}{E \cdot t^2}$$

where γ = specific weight of glass; hence $\gamma \cdot t = p$ (see Reference 2). This formula shows that the deflection of a plate increases with the fourth power of the radius and decreases with the square of the thickness.

In all cases where the flexibility cannot be neglected, it should be considered during the measuring and surfacing process. In Figure 20, the plate in the vertical position has its natural form since the vertical weight component in this position is negligible. In the horizontal position, during the finishing and polishing process, the plate conforms to its base and a high degree of flatness may be attained. However, after the plate is returned to the vertical position, because of the retention of the irregularities from the horizontal position, the surface now differs from that in the previous vertical position prior to grinding and polishing.

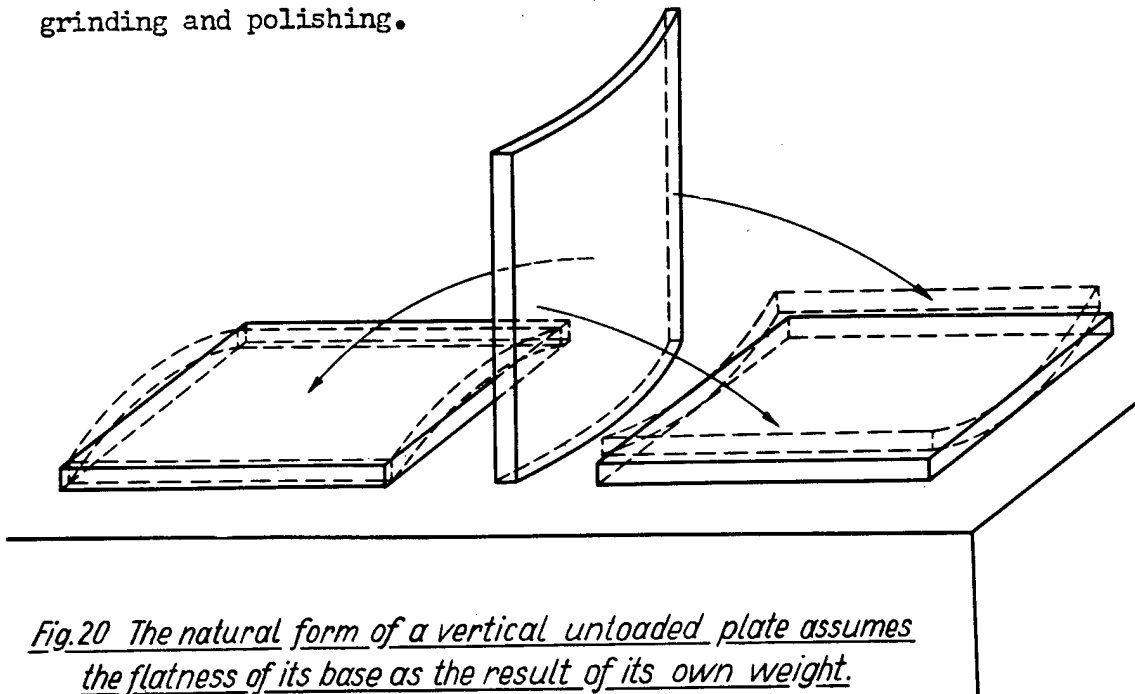

Fig.20 The natural form of a vertical unloaded plate assumes the flatness of its base as the result of its own weight.

Because the high quality plates and mirrors of interferometers used for wind tunnel purposes are normally installed in an oblique position (normally at about 45°) the problem is very difficult. An important step in this work is to find out the true flexibility of a well-ground and polished glass plate and to determine quantitatively the difference in shape between an unloaded plate (as in the vertical position) and a plate loaded by its own weight. The condition of an unloaded plate was realized by floating a plate in mercury. As long as the differences in the thickness of the plate are extremely small compared with the thickness of the plate itself the differences in buoyancy force are negligible. It can be assumed that the plate floating in mercury is uniformly supported by the mercury and has the characteristics of a weightless plate. The interference pattern of an unloaded plate can be obtained when the plate is floating in mercury, and is covered by a thin water layer. When supported in any other way the plate would show a different surface form due to the deformation by its own weight. The difference between the basic figure and the figure while the plate is bent shows the true picture of the flexibility of the plate. (See Figures 21 and 22.)

The plate to be investigated was ground and polished until the surfaces were almost uniformly curved. A comparison of both pictures in Figure 21 shows the remarkable difference in fringes which corresponds with the change of curvature. The picture of the unloaded plate shows how different the surface is from an even surface or from a uniformly curved surface of high quality. The flexibility is again illustrated in Figure 22. In the center area the size of an available comparison plate of interference quality (6" x 6") is shown in the photographs and the diagram of Figures 21 and 22. It is very difficult to get large glass plates with plane surfaces within a part of a wave length when the weight of the plates, supported horizontally around the edge, cause displacements of about 70 fringes or 35 wave lengths. In considering the flexibility, the flatness of the surface of a glass plate can be described only in terms of wave lengths for a given position of the plate and for a given supporting system.

Flexible plates must be handled very carefully during the measuring process and time must be allowed for a plate to assume its new form after its position is changed. It was observed that the original surface conditions of a well-ground and polished plate could be reproduced in different ways after handling the plate. After the plate was standing in a vertical position on a shelf for a few months, it was carried to the measuring device and floated in mercury. Shortly thereafter, the surface showed a pattern with many fringes similar to the figure when supported along the border and bent by its own weight. The pattern changed with time, however, and after several hours the original picture of the unloaded condition was observed. (See Figure 23.)

For purposes of study, the two surfaces of a test plate were prepared very carefully. When unloaded, surface No. 1 was intended to be

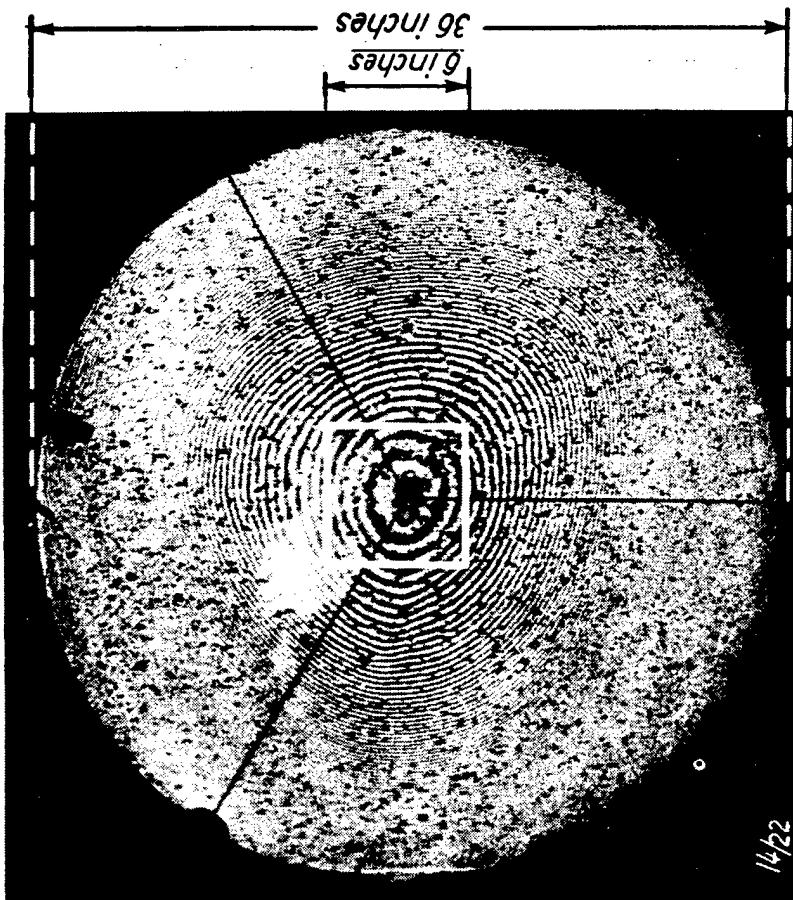

Plate supported on an elastic ring
Full effect of weight



Plate floating in mercury
No effect of weight

Fig. 21. The Flexibility of a Well Ground and Polished Glass Plate, 36 Inches in Diameter, 1-1/4 Inches Thick, Under the Influence of its Own Weight, Demonstrated by the Interference Pattern on One Surface. (Quantitative Data)

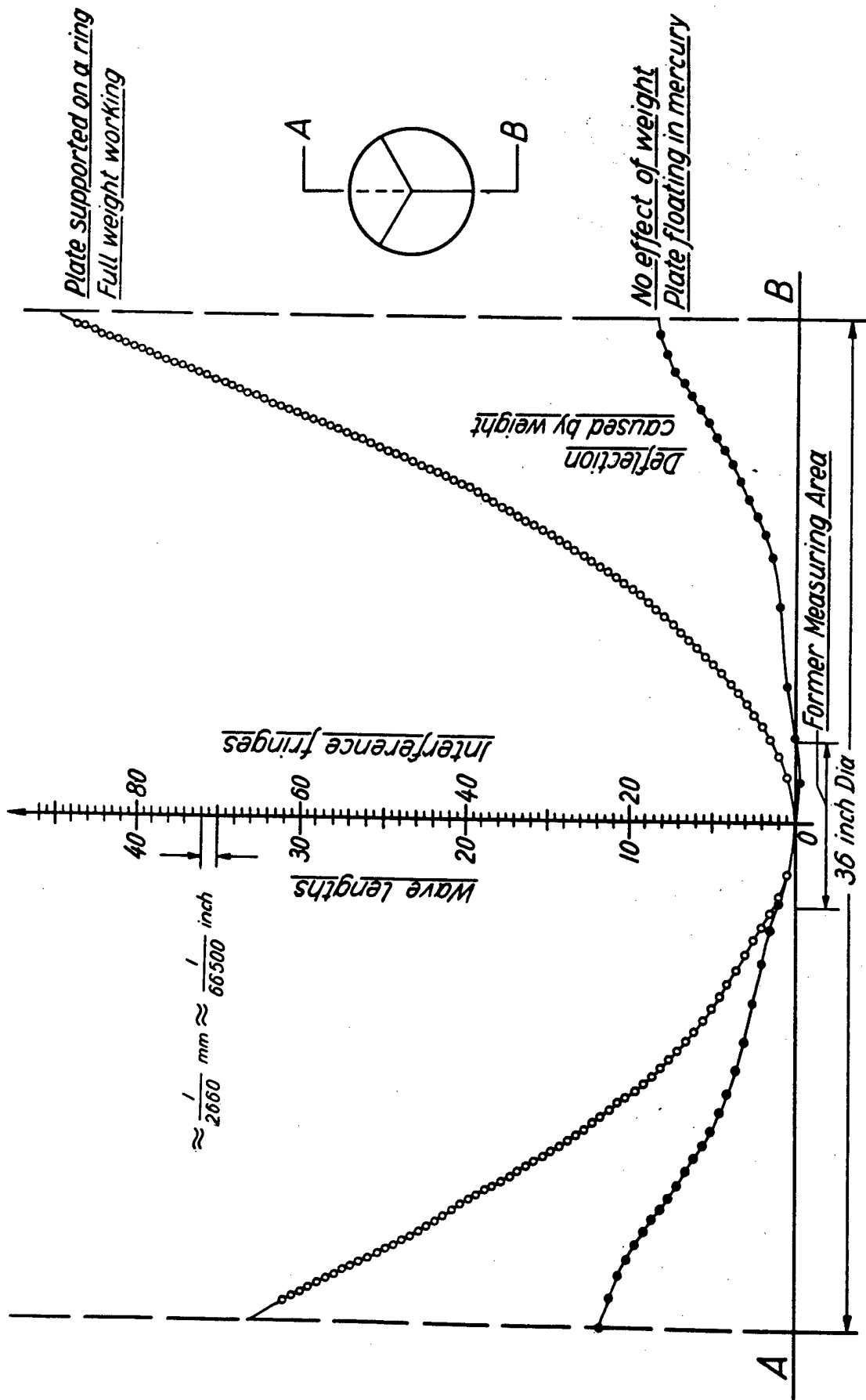
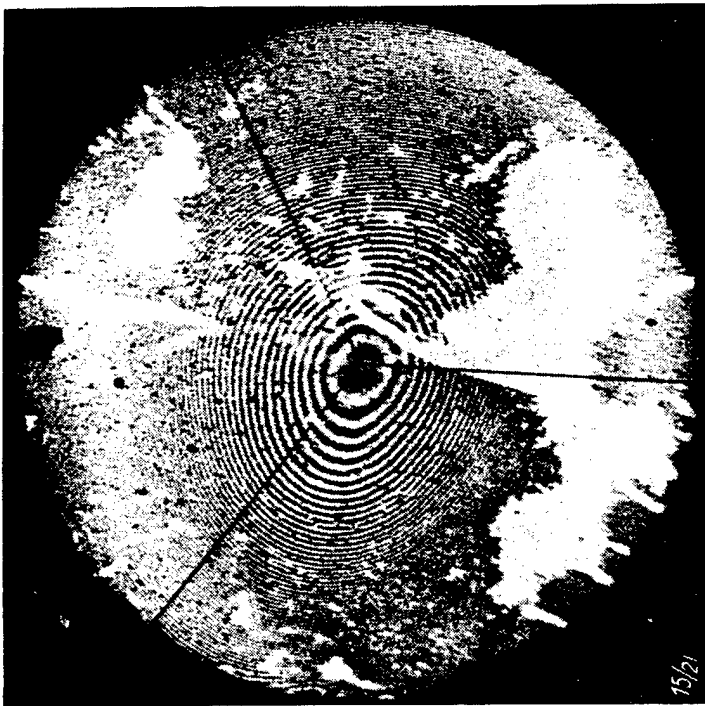

Fig. 22 The flexibility of a glass plate, 36 inches in dia, 1/4 inches thick, along section A-B



Surface, about 1 hour after being handled is still in changing process.



Final surface picture about 30 hours after being handled. (Steady condition reached about several hours after being handled)

Fig. 23. Temporary change of the surface of a well ground and polished glass plate, 36 inches in diameter, 1/4 inches thick, after removing a 3 point support and handling the plate. No effect of weight. Plate floating in mercury.

uniformly concave to show only a pure ring shaped interference pattern with 10 wave lengths maximum displacement. Surface No. 2 was intended to be uniformly concave but lower in quality and to show more pure ring shaped fringes. This plate was measured with the liquid method while floating in mercury and covered by a water layer. The result is presented in Figure 24. The fact illustrated is that the original pattern in both surfaces was entirely different from the pattern desired. Both surfaces are very irregular. Surface No. 1 was more uniformly curved than surface No. 2. The pattern in Figure 25 shows a saddle figure representing a surface of low accuracy because it has two different signs of curvature in the same surface, and a transition between both. Both surface pictures are evaluated along two sections, illustrated in Figure 25 for the better surface, No. 1, and in Figure 26 for the poorer surface, No. 2.

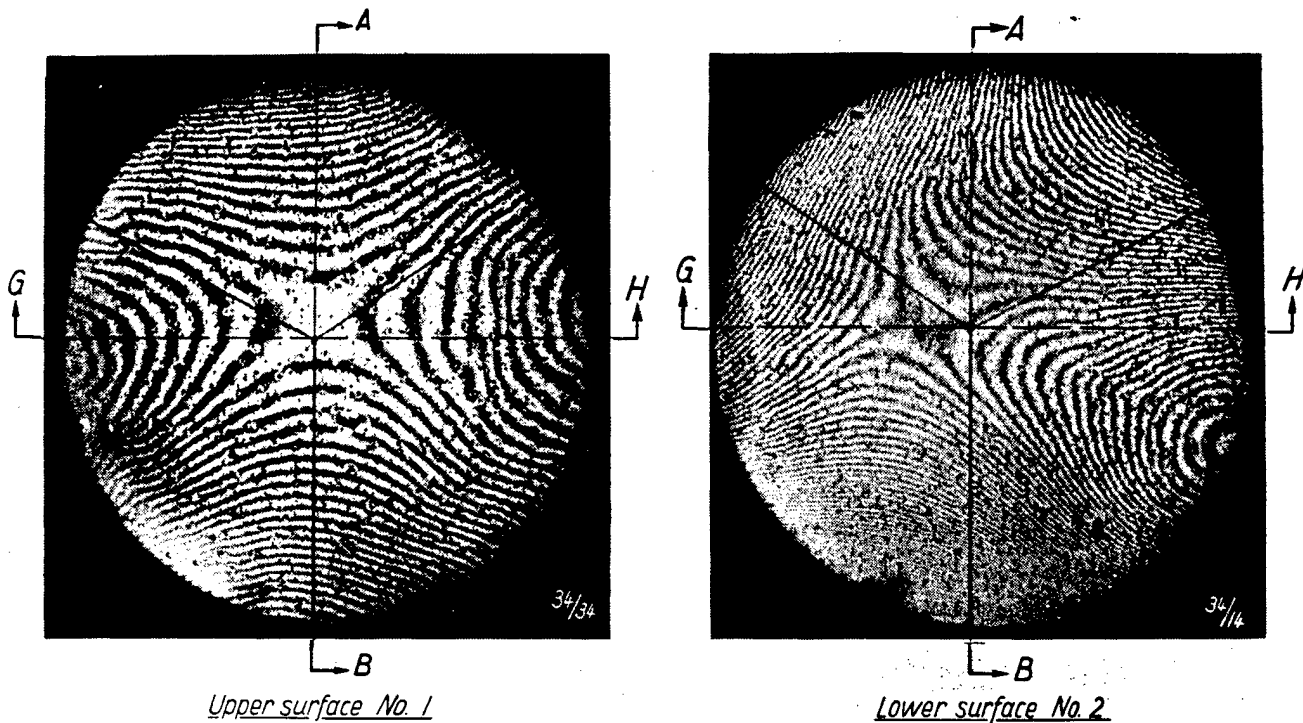

Fig. 24. The actual surfaces of a well ground and polished sample plate of 36 inch $\frac{1}{4}$ inch thick $\frac{1}{4}$ inches thick, prepared as a plate with ring shaped pattern when unloaded.

A perspective representation is made for surface No. 1, (Figure 27), demonstrating some of the basic problems connected with the problem of building interferometers of unusually large dimensions.

It is the belief of the authors that this problem can be solved only by controlling the flexibility during the grinding and polishing process and by using a quantitative measuring method which permits a picture of the entire surface in one step.

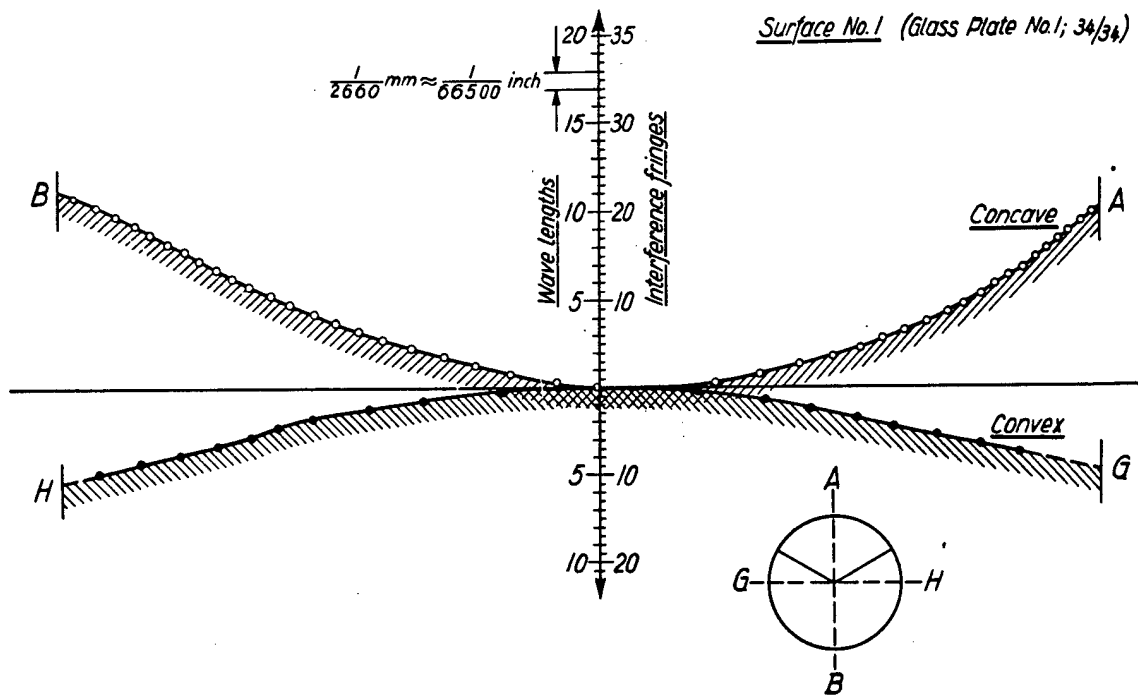

Fig. 25 The actual surface profile of a well ground and polished sample plate 36 inches in diameter, 1/4 inches thick, prepared as a plate with a uniformly curved surface and only a few rings in the pattern.

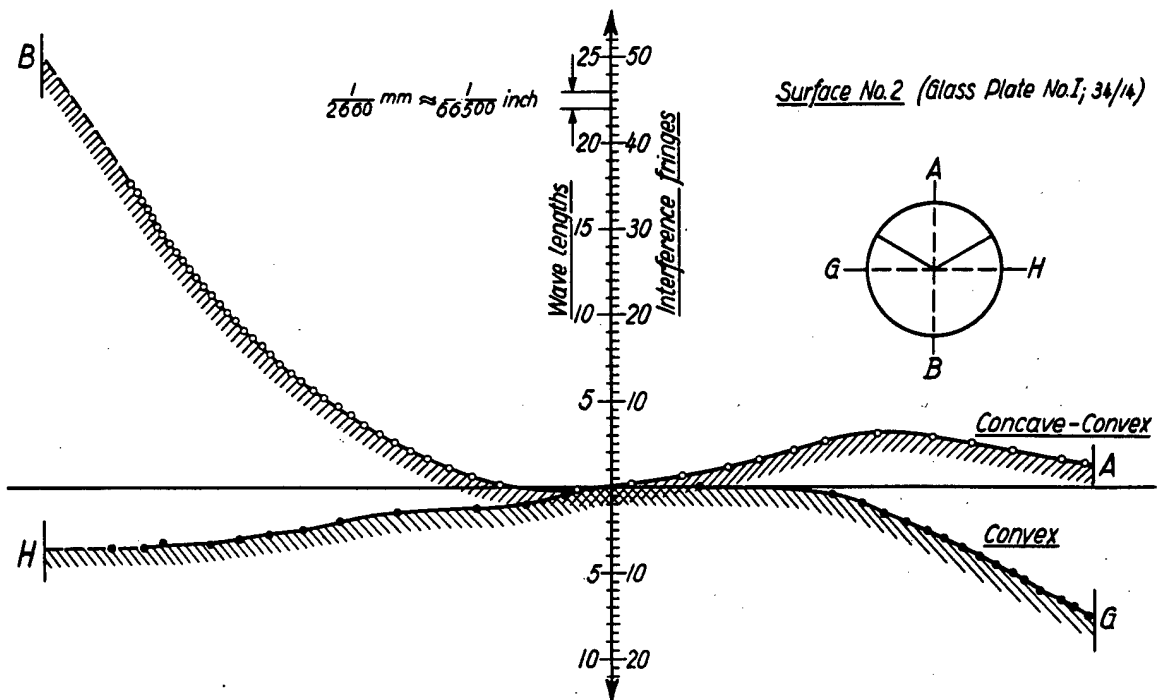

Fig. 26. The actual surface profile of a well ground and polished sample plate 36 inches in diameter, 1/4 inches thick, prepared as a plate with a uniformly curved surface and a larger number of rings in the pattern than in surface No. 1

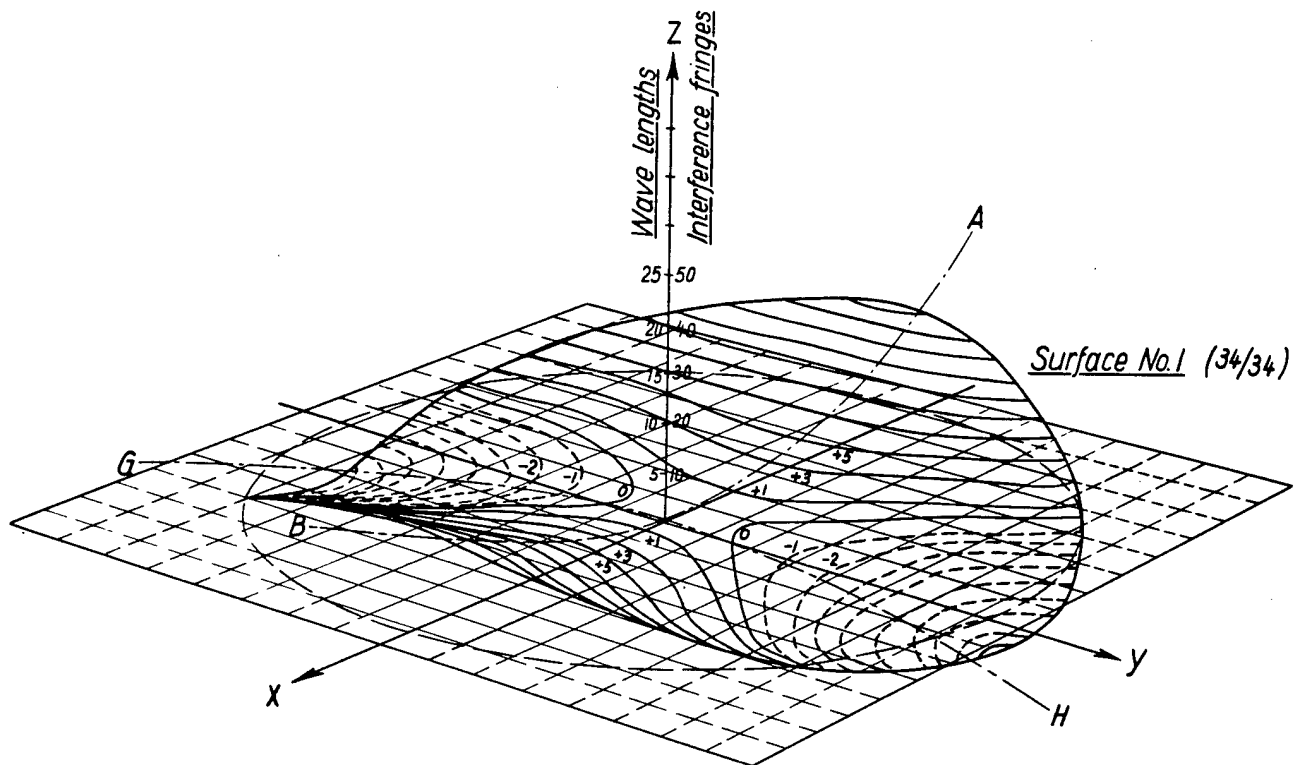

Fig.27 Perspective representation of the actual surface of the well ground and polished sample plate 36 inches in diameter, 1/4 inches thick.

SECTION VI

OPTICAL CORRECTIONS BY DEFORMING REFLECTING SURFACES

In the previous discussion it was determined that the accuracy of 36 inch plates should be 16 times higher than the accuracy of 9 inch plates. If small plates with about 1/4 fringe over the entire field represent the average which are available for interference purposes, the difficulty of increasing this accuracy 16 times in order to get 36 inch plates with 1/4 fringe inaccuracy over the entire field may be appreciated. The question arises whether or not it is possible at all to obtain such qualities on large thin sheets by ordinary grinding and polishing and at reasonable cost. After it was found that optical corrections could be made by deforming reflecting surfaces of small interferometer mirrors having slight but uniform curvature, the first step of

deformation on large sheets, 36 inches in diameter, was attempted. (See Reference 6.) One of the plates described in the foregoing section was used as a test plate in spite of the fact that its surface quality was much too poor for any interference purposes.

The liquid interference method was used in order to find out what amount of deformation could be realized on large plates of the size under consideration and how the deformation process worked. One example is illustrated in the four photographs of Figure 28. The test arrangement was the same as shown in Figure 13 except for the supporting system for the plate to be tested and deformed. Photograph 1, Figure 28, shows the interference pattern on the surface of the test plate when the plate was unloaded by floating it in mercury. Photograph 2, Figure 28, shows the same plate while supported on 12 border screws of a deformation support plate. Only a thin water layer rested on the glass plate surface; hence it was, in effect, loaded by only its own weight. Each border screw was opposed by a counter screw to fix the location of the plate when more screws from underneath were used to deform it. The almost symmetrical appearance of the surface figure of the plate while bent by its own weight in Photograph 2, Figure 28, was the result of a careful adjustment of the 12 border screws. The initial figure appeared very different and irregular. The main idea of the tests was to find out how the bending process worked if only the center screw were used, and what improvement of the result could be expected when a number of deforming screws were used.

Photograph 3, Figure 28, illustrates the plate surface when the plate was lifted by the center screw so far that the former concave surface had already changed in the center area to convex and the plus and minus displacements had about the same average value. The evaluation of this photograph at three different sections is shown in Figure 29. It shows that, within the main part of the surface area, the total displacement could be reduced to about $1/20$ f with the center screw only.

The next step of deforming the plate with a number of screws is illustrated in Photograph 4, Figure 28. It was found by the experiment that no definite relationship for the bending could be established if a number of screws were used, because each screw spreads its influence over the entire area in an uncontrollable manner. Illustration 4, Figure 28, represents the average condition which could be obtained. As seen in Figure 30, the result was almost the same for the larger part of the surface as it was by the deformation with the center screw alone. Only the border area was somewhat improved, indicating that the elastic characteristics of the deformed surface are largely controlled by the effect of the center screw.

In the present example, with a relatively poor plate, better results could not be expected. Of course, in a practical use of the deforming process for making optical corrections, the curvature of the shaped plate should be uniform (i.e., showing a ring shaped interference pattern when



Basic surface pattern when unloaded.
No uniformity. Plate floating in mercury

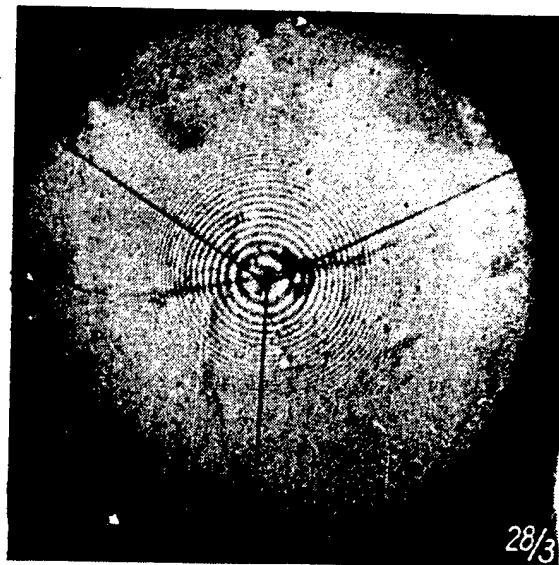
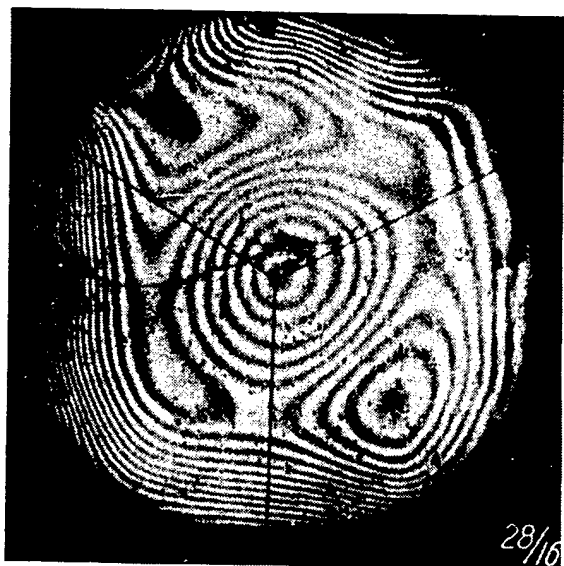
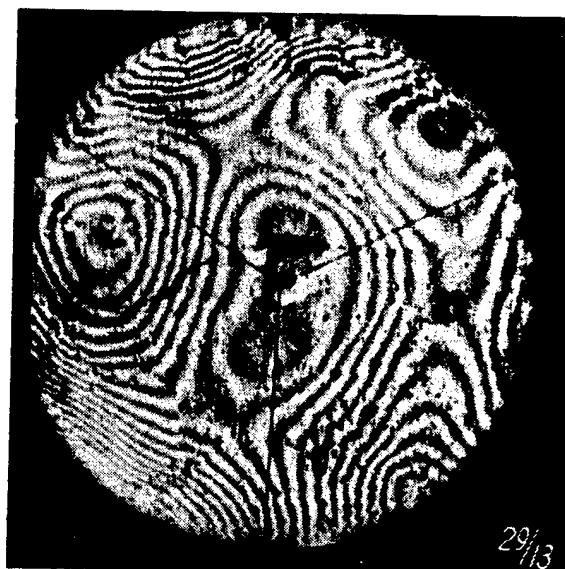

Plate deformed by its own weight, when
supported on 12 border screws.



Deformation made by only one center screw



Deformation made by a number of
different screws.

Fig.28 The influence of the deformation on the surface shape of a well
ground and polished glass plate 36 inches in diameter, 1/4 inches thick.

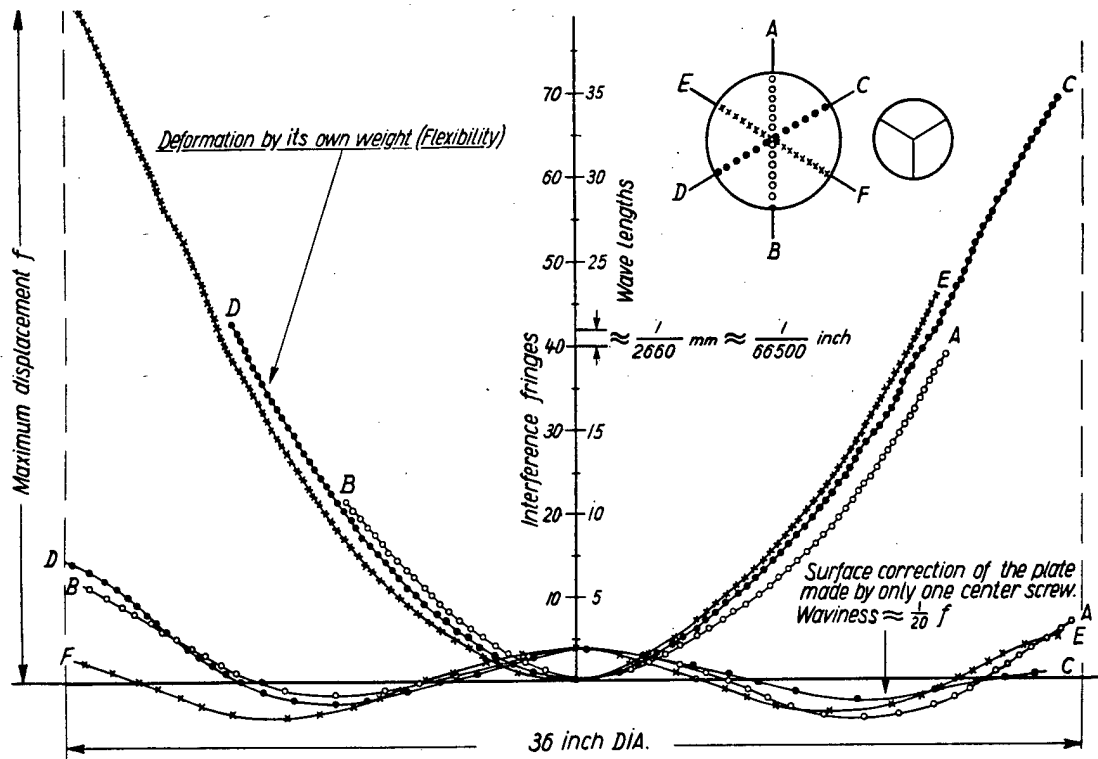

Fig.29 The deformation of a well ground and polished glass plate 36 inches in diameter, $\frac{1}{4}$ inches thick by only one center screw while supported between 12 screws and lock screws along the periphery

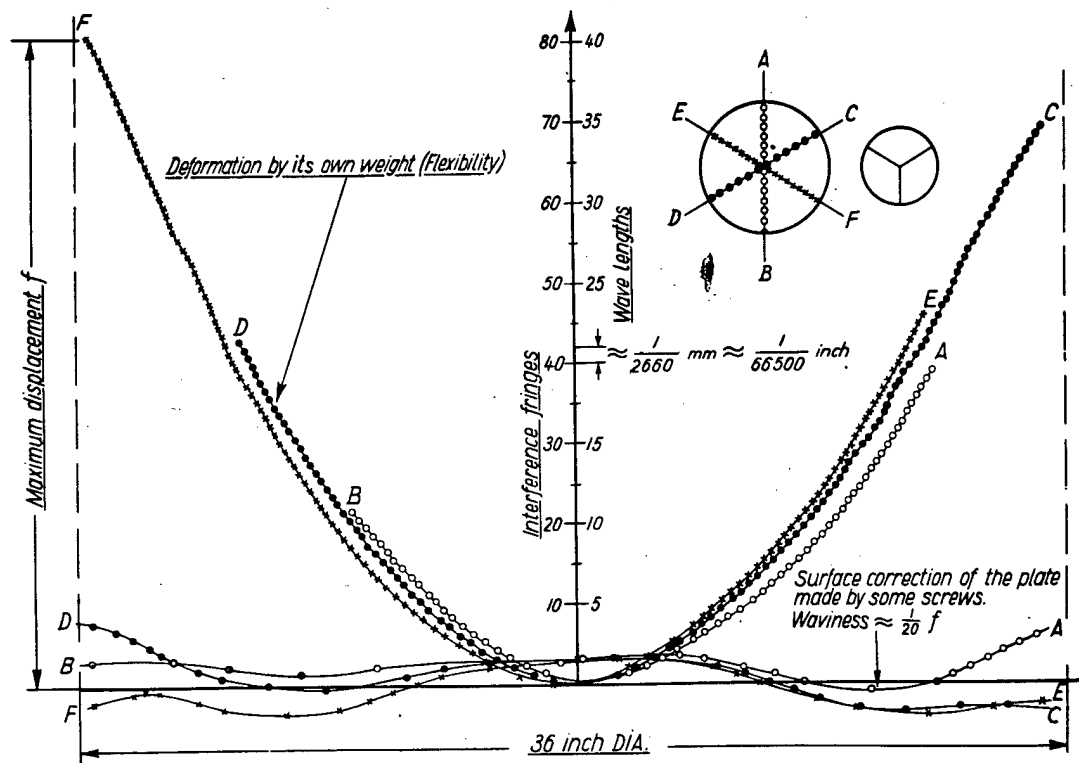

Fig.30 The deformation of a well ground and polished glass plate 36 inches in diameter, $\frac{1}{4}$ inches thick by several screws while supported between 12 screws and lock screws along the periphery.

not loaded) and the number of fringes should be much smaller. If, for instance, a plate would show 10 ring shaped interference fringes, corresponding with a total displacement of 5 wave lengths, and if the same correction could be obtained, that is, to $\pm 1/20 f$, the final accuracy of the plate would then correspond with 1/2 fringe, or $1/4 \lambda$ displacement. This could be achieved by deforming the plate with the center screw only. As soon as glass plates of the size desired with a uniformly curved surface are available, the next step; to deform and study such plates; will be started.

SECTION VII

SUMMARY

The biggest problem arising in the construction of interferometers is the flexibility of large, relatively thin, glass plates. As far as is known, no quantitative measuring method existed up to the present for making exact surface pictures of the entire area of unusually large plates in one step.

An interference method is described for measuring the surface conditions exactly. Water layers were used which covered the surface to be measured and interference phenomena produced within the liquid layer. These liquid layers are almost absolutely flat and steadily horizontal. On this basis, quantitative measurement on 36 inch diameter plates and interference pictures, showing almost the entire area, were made in one step.

The interference liquid method used for the 36 inch plates is not limited by these dimensions. It should work just as correctly for any desired dimensions of plate surfaces because of the nature of liquids to be flat and horizontal, if free from disturbances. The flexibility problem of glass plates 36 inches in diameter by 1-1/4 inches thick was investigated by the liquid interference method in connection with different supporting systems. The condition of an unloaded plate, as if standing in the vertical position, was realized by floating the plate in mercury. The surface pattern of an unloaded plate shows the basic surface form which should be equal to a uniformly curved surface showing a pure ring shaped pattern.

Every deformation process connected with the flexibility and caused either by the weight of the plate when supported in the desired position, or mechanically by screws in order to make optical corrections, was started from this basic pattern of the unloaded plate. Remarkable improvement was found when using a center screw only for deforming a 36 inch circular glass plate which showed about 80 fringes when supported with 12 screws around the periphery. The total amount of deflection was reduced to about 1/20 of the original deflection. Using a number of screws for the deformation, instead of the center screw only, did not bring a

remarkable improvement of the result. This means that the average condition is almost dominated by the effect of the center force only. This result seems to be very promising for deforming plates with a uniformly curved surface and with as few as 5 to 10 pure ring shaped fringes as the basic figure.

BIBLIOGRAPHY

1. Pohl, R. W., Einfuehrung in die Optik. 2 3 Auflage Berlin, Springer Verlag, 1941.
2. Foepl, A., Technische Mechanik, Dritter Band Festigkeitslehre. 12. Auflage. Oldenburg Verlag, Berlin Munchen, 1940.
3. Zobel, Th. W., Verwendung von Lichtinterferenzen in der Technischen Messung. VDI - Zeitschrift, Bd, 81, N 22 (1937).
4. Zobel, Th. W., Stroemungsmessung durch Lichtinterferenz. Forschungsbericht FB 1167 (1940). Also: "Flow Measurement by Means of Light Interference." NACA TM 1253, (August 1949)
5. Zobel, Th. W., Fortschritte in der Optischen Stroemungsmessung Schriften der Deutschen Akademie der Luftfahrtforschung. Mitt: 5008/44g and FB 1934. (1944).
6. Zobel, Th. W., Optical Corrections for Interference Measurements by a Controllable Deformation of Reflecting Surfaces. USAF Technical Report No. 5664. 1948.
7. Ingalls, Albert G., Amateur Telescope Making. Scientific American, Inc. Book I. 1948 Page 61.