

**NAVAL POSTGRADUATE SCHOOL**  
**Monterey, California**



**THESIS**

**PIANNING, DESIGNING AND IMPLEMENTING  
A NETWORK FOR  
THE NAVAL RESERVE**

by

Dale E. Drake

March 2000

Thesis Advisor:  
Associate Advisor:

Douglas E. Brinkley  
William J. Haga

**Approved for public release; distribution is unlimited.**

**DTIC QUALITY INSPECTED 1**

**20000525 060**

# REPORT DOCUMENTATION PAGE

Form Approved  
OMB No. 0704-0188

Public reporting burden for this collection of information is estimated to average 1 hour per response, including the time for reviewing instruction, searching existing data sources, gathering and maintaining the data needed, and completing and reviewing the collection of information. Send comments regarding this burden estimate or any other aspect of this collection of information, including suggestions for reducing this burden, to Washington headquarters Services, Directorate for Information Operations and Reports, 1215 Jefferson Davis Highway, Suite 1204, Arlington, VA 22202-4302, and to the Office of Management and Budget, Paperwork Reduction Project (0704-0188) Washington DC 20503.

1. AGENCY USE ONLY (Leave blank)		2. REPORT DATE March 2000	3. REPORT TYPE AND DATES COVERED Master's Thesis
4. TITLE AND SUBTITLE : Planning, Designing and Implementing a Network for the Naval Reserve			5. FUNDING NUMBERS
6. AUTHOR(S) Dale E. Drake			
7. PERFORMING ORGANIZATION NAME(S) AND ADDRESS(ES) Naval Postgraduate School Monterey, CA 93943-5000			8. PERFORMING ORGANIZATION REPORT NUMBER
9. SPONSORING / MONITORING AGENCY NAME(S) AND ADDRESS(ES) N/A			10. SPONSORING / MONITORING AGENCY REPORT NUMBER
11. SUPPLEMENTARY NOTES The views expressed in this thesis are those of the author and do not reflect the official policy or position of the Department of Defense or the U.S. Government.			
12a. DISTRIBUTION / AVAILABILITY STATEMENT Approved for public release; distribution is unlimited.			12b. DISTRIBUTION CODE
13. ABSTRACT (maximum 200 words) This thesis focuses on an analysis of the technology and steps involved in planning, designing and implementing a network for the Naval Reserve Force. The Naval Reserve is undergoing a multi-year program that will dramatically upgrade the Naval Reserve Network. The upgrades are needed to establish an effective Wide Area Network that is compliant with Department of the Navy Chief Information Officer's information technology standards guidance. Through the study, the challenges to implementing an effective network were identified as well as recommended strategies for successfully implementing the network. The thesis includes a requirements analysis of a typical Reserve Center and a recommendation for a standardized Reserve Center Local Area Network architecture. An overall standard network architecture is needed to improve system performance and interoperability. In addition, the thesis studies how to best stimulate the changes to business practices that will be required to ensure that the network will not be underutilized. The recommendations and information presented will benefit the Naval Reserve Force in their ongoing efforts to implement an effective Wide Area Network and to standardize their Information Technology infrastructure.			
14. SUBJECT TERMS Wide Area Network, Local Area Network, WAN, LAN, Network Design, Media, Topology, Hub, Router, Managing Planned Change.			15. NUMBER OF PAGES 111
			16. PRICE CODE
17. SECURITY CLASSIFICATION OF REPORT Unclassified	18. SECURITY CLASSIFICATION OF THIS PAGE Unclassified	19. SECURITY CLASSIFICATION OF ABSTRACT Unclassified	20. LIMITATION OF ABSTRACT UL

NSN 7540-01-280-5500

Standard Form 298 (Rev. 2-89)  
Prescribed by ANSI Std. Z39-18

THIS PAGE INTENTIONALLY LEFT BLANK

Approved for public release; distribution is unlimited

**PLANNING, DESIGNING AND IMPLEMENTING A NETWORK  
FOR THE NAVAL RESERVE**

Dale E. Drake  
Lieutenant Commander, United States Naval Reserve  
B.S., SUNY Maritime College, 1983

Submitted in partial fulfillment of the  
requirements for the degree of

**MASTER OF SCIENCE IN INFORMATION TECHNOLOGY MANAGEMENT**

from the

**NAVAL POSTGRADUATE SCHOOL  
March 2000**

Author:

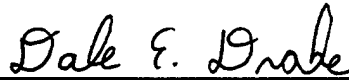

Dale E. Drake

Approved by:

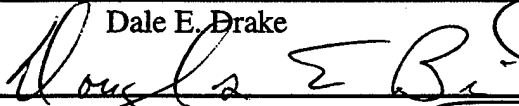

Douglas E. Brinkley, Thesis Advisor



William J. Haga, Associate Advisor

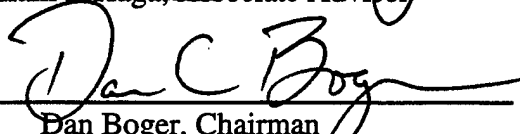

Dan Boger, Chairman  
Information Systems Academic  
Group

THIS PAGE INTENTIONALLY LEFT BLANK

## ABSTRACT

This thesis focuses on an analysis of the technology and steps involved in planning, designing and implementing a network for the Naval Reserve Force. The Naval Reserve is undergoing a multi-year program that will dramatically upgrade the Naval Reserve Network. The upgrades are needed to establish an effective Wide Area Network that is compliant with Department of the Navy Chief Information Officer's information technology standards guidance. Through the study, the challenges to implementing an effective network were identified as well as recommended strategies for successfully implementing the network.

The thesis includes a requirements analysis of a typical Naval Reserve Center and a recommendation for a standardized Reserve Center Local Area Network architecture. An overall standard network architecture is needed to improve system performance and interoperability. In addition, the thesis studies how to best stimulate the changes to business practices that will be required to ensure that the network will not be underutilized. The recommendations and information presented will benefit the Naval Reserve Force in their ongoing efforts to implement an effective Wide Area Network and to standardize their Information Technology infrastructure.

THIS PAGE INTENTIONALLY LEFT BLANK

## TABLE OF CONTENTS

I. INTRODUCTION.....	1
A. PURPOSE.....	1
B. BACKGROUND .....	2
1. Mission .....	2
2. Infrastructure Plan 2000 .....	3
3. Naval Reserve Network (NAVRESNET).....	5
4. Benefits.....	6
C. RESEARCH QUESTIONS.....	9
D. SCOPE .....	10
E. METHODOLOGY .....	10
II. NETWORKS OVERVIEW .....	11
A. NETWORKS .....	11
1. Peer-to-Peer Networks.....	12
2. Client-Server Networks .....	13
3. Hybrid Networks .....	13
B. NETWORK TOPOLOGY .....	14
1. Bus Topology .....	14
2. Star Topology .....	15
3. Ring Topology.....	17
4. Star Bus and Star Ring.....	18
5. Mesh Topology.....	18
C. NETWORK MEDIA .....	19
1. Twisted-Pair Cable .....	20
2. Coaxial Cable .....	21
3. Fiber-Optic Cable .....	22
4. Cable Selection Considerations .....	24
D. NETWORKS OVERVIEW SUMMARY .....	25
III. LAN DESIGN FUNDAMENTALS .....	27
A. NEEDS ANALYSIS.....	29
1. Compliance with DON Information Technology Standards Guidance (ITSG).....	30
2. E-mail Connectivity.....	31
3. Internet/WWW Connectivity.....	31
4. Sharing of Peripherals .....	32
5. Centralized File Service.....	32
6. Network Security.....	32
7. Network Training .....	33
8. Computer Lab.....	33
9. Video Tele-Conferencing/Training(VTC/VTT).....	33
10. Document the Current Network and the Vision for the Future.....	34
B. SITE ASSESSMENT.....	35
C. EQUIPMENT INVENTORY/MATCHING .....	35
D. CONFIGURATION PLAN .....	36
E. SERVER DIRECTORY STRUCTURE .....	36
F. IMPLEMENTATION SCHEDULE .....	37
G. SYSTEM LOG.....	37
H. LAN DESIGN SUMMARY .....	37
IV. RESERVE CENTER LAN ARCHITECTURE .....	39

A. ETHERNET.....	42
B. CATEGORY 5 ENHANCED CABLE.....	44
C. NETWORK INTERFACE CARDS (NIC).....	47
D. HUBS.....	47
E. CISCO 3940 ROUTER.....	49
F. SERVER.....	50
1. Server Operating System.....	51
2. Server Hardware.....	54
G. UNINTERRUPTIBLE POWER SUPPLY (UPS).....	55
H. BACKUP SYSTEM.....	56
I. MODEM/REMOTE ACCESS SERVICE (RAS).....	57
J. LAN ARCHITECTURE SUMMARY.....	58
V. MANAGING PLANNED CHANGE.....	61
A. MANAGING CHANGE.....	62
1. Establishing a Sense of Urgency.....	62
2. Creating the Guiding Coalition.....	65
3. Developing a Vision and Strategy.....	66
4. Communicating the Change Vision.....	68
5. Empowering Employees for Broad-Based Action.....	70
6. Planning for and Creating Short-Term Wins.....	72
7. Consolidating Improvements and Producing Still More Change.....	73
8. Anchoring Changes in the New Culture.....	75
B. STRATEGY FOR SUCCESSFULLY MANAGING CHANGE.....	76
1. Revitalize the CNRF IT Web Site.....	76
2. Revise the CNRF IT Mission and Vision.....	77
3. Develop a Information Management (IM) Strategic Plan.....	77
4. Biannual Information Technology Summit.....	77
5. Information Technology Newsletter.....	78
6. Fiscal Year IT Goals and Objectives.....	78
7. Training.....	78
8. Recognition and Awards.....	79
9. Centralized Helpdesk.....	79
10. Network Architecture.....	79
C. MANAGING PLANNED CHANGE SUMMARY.....	80
VI. SUMMARY AND CONCLUSIONS.....	83
A. SUMMARY.....	83
B. KEY RECOMMENDATIONS.....	85
1. Standardized Network Architecture.....	85
2. Centralized Management.....	86
3. Windows® 2000 Operating System.....	86
4. Standardized Server Configuration.....	87
5. Centralized Procurement.....	87
6. Training Plan.....	87
7. Document the Network.....	88
8. Strategy for Managing Change.....	88
C. TOPICS FOR FUTURE RESEARCH.....	89
D. CONCLUSIONS.....	90
APPENDIX A. SOURCES OF GUIDANCE ON NETWORKS.....	93
APPENDIX B. NETWORK DESIGN TOOLS.....	95
LIST OF REFERENCES.....	109
INITIAL DISTRIBUTION LIST.....	111

## LIST OF FIGURES

1. Figure 1-1. Organizational Structure of the Naval Reserve.....	4
2. Figure 1-2. Revised Organizational Structure of the Naval Surface Reserve.....	5
3. Figure 2-1. Bus Topology.....	14
4. Figure 2-2. Star Topology.....	17
5. Figure 2-3. Ring Topology. ....	18
6. Figure 2-4. Single-Mode Fiber . ....	23
7. Figure 2-5. Multi-Mode Fiber.....	24
8. Figure 4-1. Naval Reserve Center LAN Design Template. ....	41
9. Figure 4-2. Naval Reserve Center LAN Design Template. ....	42
10. Figure 4-3. Pin Specifications for T-568A. ....	46
11. Figure 5-1. Sources of Complacency.....	63
12. Figure 5-2. Barriers to Empowerment.....	70

THIS PAGE INTENTIONALLY LEFT BLANK

## LIST OF TABLES

1. Table 2-1. Topology Summary Comparison. ....	19
2. Table 2-2. Twisted -Pair Cable Summary Comparison. ....	21
3. Table 2-3. Cable Specifications Summary.....	25
4. Table 4-1. Ethernet Summary Comparison. ....	44
5. Table 4-2. Server Hardware Configuration Guidance. ....	54

THIS PAGE INTENTIONALLY LEFT BLANK

## I. INTRODUCTION

### A. PURPOSE

The primary focus of this thesis is to provide a recommendation for a standardized Reserve Center Local Area Network (LAN) architecture. Recommendations will be developed based on an in-depth study of network Information Technology (IT) and a requirements analysis of a typical Naval Reserve Center. The thesis is intended to provide an overview of information on network fundamentals, implementation, documentation, administration and planning for future expansion. In addition, this thesis will analyze the establishment of the Naval Reserve Network (NAVRESNET) from the perspective of how to best manage and stimulate change. Significant changes to business practices will be required to take full advantage of the network capabilities and the full support of senior leadership is needed to ensure its success.

This thesis will provide the essential information an Information Technology manager would need to successfully implement a LAN at a Naval Reserve Center and will serve as a framework for standardizing the LAN architecture. Written in a comprehensive format that allows the user to have a minimal amount of technical background in networking, this thesis will provide the background information needed to better understand the complexities of the Naval Reserve's Wide Area Network (WAN) and to conceptualize the workings of a LAN at a Reserve Center. The recommendations

and information presented will benefit the Naval Reserve Force in their ongoing efforts to implement an effective WAN and to standardize their Information Technology infrastructure. References will be included to direct the user to sources of additional detailed information for further guidance and study.

## **B. BACKGROUND**

### **1. Mission**

The Active Navy is relying more and more on Selected Reservists to support mission accomplishment. The Naval Reserve's mission calls for a trained Reservist who can step in and perform the same duties as his active duty counterpart, thereby contributing directly and quickly to the Active Navy. The mission of the Naval Reserve Force is "to maintain assigned personnel and equipment in a state of readiness and availability which will permit rapid employment in the event of partial or full mobilization and to provide peacetime contributory support to the active Navy as requested" [Ref. CNSRF, 1999]. The downsizing of our military forces in recent years has increased the opportunities and requirements for the Naval Reserve to provide peacetime contributory support, thus making them a more valuable asset to the Active Navy. The readiness of the Naval Reserve Force is a measure of a Selected Reservist's or a unit's level of preparedness to mobilize in support of the mission of the Naval Reserve.

The training strategy of the Surface Reserve Force is to select the most effective method from available resources to accomplish mobilization training requirements and

provide peacetime support [Ref. CNSRF, 3502.1C, 1998]. This is the point at which IT infrastructure becomes important, and the establishment of the NAVRESNET becomes tantamount to that goal. A WAN is expected to provide an effective method to accomplish training and provide contributory support. It is an essential tool in carrying out the Naval Reserve Force training and mission accomplishment given the complexities of coordinating the Naval Reserve Force. Drill limitations, unit placement, billet location, and unit composition are among the factors affecting the Reserve training strategy. All of these components could be better administered through the use of a WAN.

## **2. Infrastructure Plan 2000**

The organizational structure of the Naval Reserve has been undergoing dramatic changes in the recent past due to its changing mission, advances in information technology and reductions in funding. Currently there are ten Echelon IV Readiness Commands and 158 Surface Reserve Centers located throughout the United States. Commander Naval Surface Reserve Force recently published Infrastructure Plan 2000 which involves a restructuring of echelon IV and V commands in order to develop a more cost effective and efficient organization. Optimal use of information technology will be critical to the success of this plan. The overall Naval Reserve Force organizational structure is depicted in figure 1-1. The Naval Reserve Force comprises approximately 15,750 Active Duty and 79,000 Selected Reservists assigned to Reserve Centers throughout the United States. This represents 14% of the Total Naval Force (Active – 57.2%, Selected Reservists – 14%, & Individual Ready Reserve – 28.8%) that is available

for the defense of the national interests of the United States. The Surface Reserve Force represents approximately 77% of the total Naval Reserve Force. [Ref. CNRF, 1999]

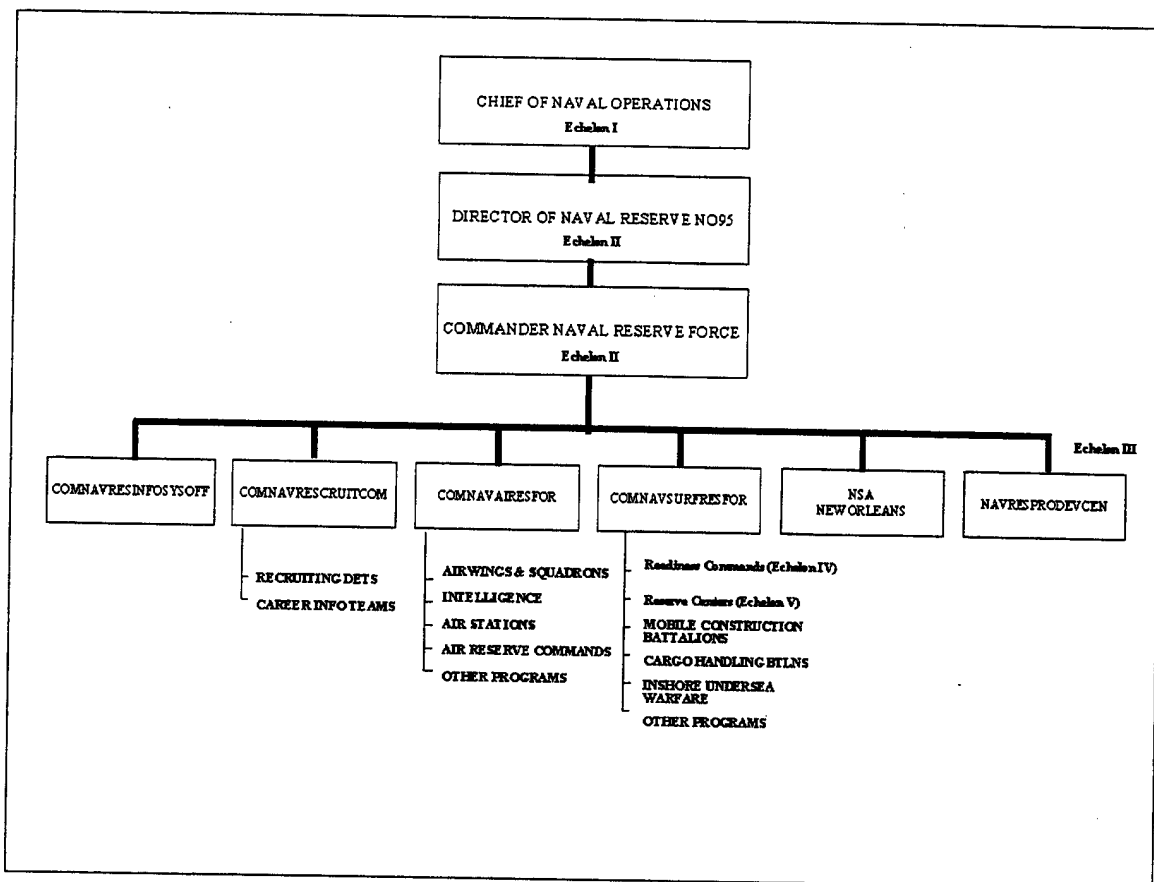

Figure 1-1. Organizational Structure of the Naval Reserve [Ref. After CNRF, 1999].

The central concept of the plan is to eliminate the ten echelon IV commands. The 16 largest Reserve Centers then will assume responsibility for the oversight and support of the smaller Reserve Centers within their respective geographic regions. The larger centers will be renamed as Naval Reserve Fleet Support Commands, concurrently fulfilling the roles performed by the Readiness Command and a Reserve Center. This restructuring translates to an overall flattening of the pyramid structure of the Naval

Reserve and is a trend that has been evolving over the past ten years. The planned revised Naval Surface Reserve organization and manpower distribution is depicted in figure 1-2.

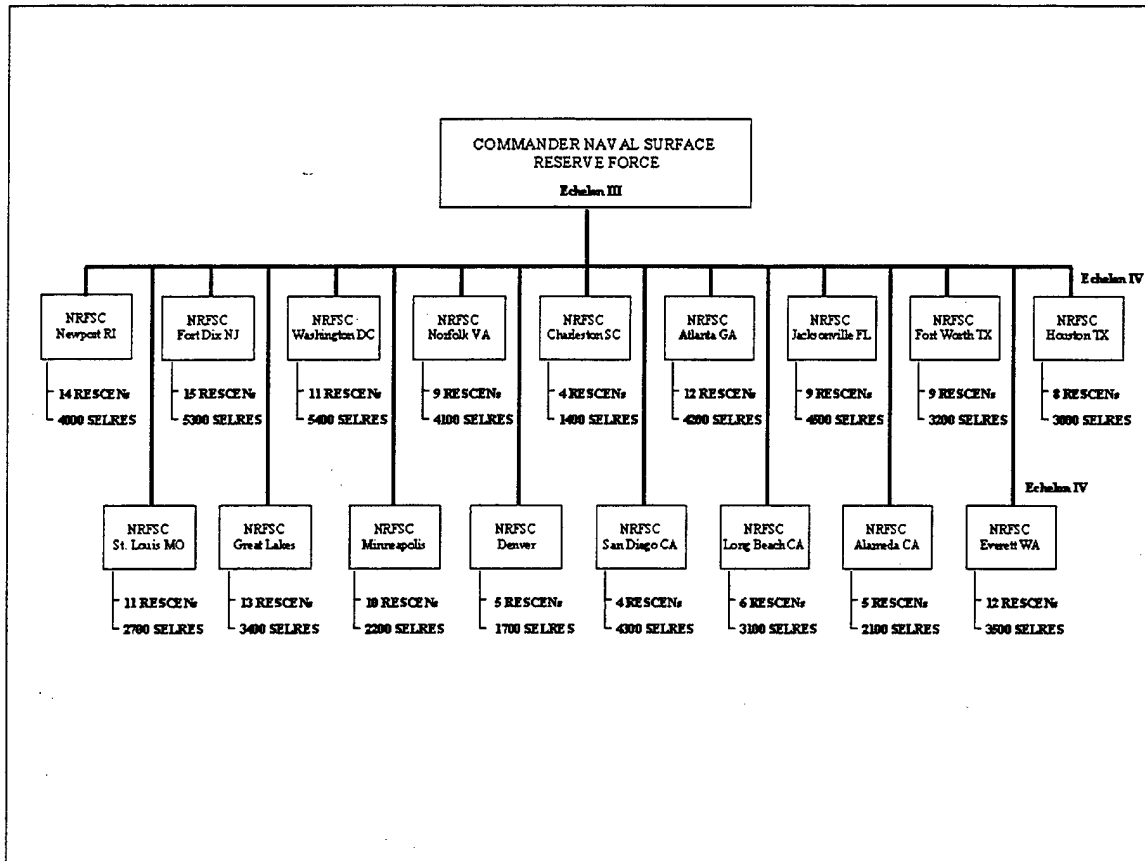

Figure 1-2. Revised Organizational Structure of the Naval Surface Reserve.

### 3. Naval Reserve Network (NAVRESNET)

Advances in Information Technology have been vital in allowing the Naval Reserve to be successful in the ongoing restructuring of its organization. One aspect of IT enhancements has been the implementation of a plan to establish a Wide Area Network (WAN) for the Naval Reserve. The network has been phased in over the past five years and Local Area Networks (LANs) currently are being established at Reserve Centers. The

WAN system will be an important aspect of the success of Infrastructure Plan 2000. The WAN is needed to effectively communicate within the reserve's organization as well as with their active Navy counterparts. Reserve contributory support to the active duty gaining commands, administrative requirements and training will be fulfilled more efficiently using the new WAN system.

The WAN currently consists of a total of 175 Naval Reserve Force sites that are in various phases of establishing an effective LAN. Of the 175 sites, 8 are connected to the Naval Reserve Network (ATT 56kb leased lines), 26 via the NIPRNET and 168 via a 1-800 dial-up connection. This approach is very limited in capabilities and overall performance. A Commander Naval Reserve Force (CNRF) sponsored Frame Relay Project is underway which involves installing and configuring a Cisco 3640 Router at each site and the establishment of Sprint FTS 2001 Frame Relay Service. The project will be completed in three phases, and phase 1 (22 sites) is currently underway. The Sprint Frame Relay Service will provide fractional T-1 access to all sites (256/512kbs access speeds). This represents a significant increase in performance and increased functionality of the network.

#### **4. Benefits**

The WAN is expected to support the Naval Reserve in making critical changes in how they do business and ultimately result in increased readiness, contributory support and overall productivity. Numerous benefits can be gained through the use of IT such as improved productivity, more efficient training, increased contributory support and

reduced costs. Central to these benefits is the establishment of a standardized network infrastructure that is compliant with DON Chief Information Officer (CIO) Information Technology Standards Guidance and making significant changes to business practices that will fully utilize the available technology. By creating a standard IT infrastructure and developing proficiency on standard systems, the overall operational efficiency can be improved and a seamless link between the Reserve and Active Duty components can be promoted. A study of Reserve Center requirements and networking principles will help to support the establishment of a standard IT infrastructure, effective LANs and the long-term administration of the IT Infrastructure.

The overall benefit of implementing a WAN is improved Fleet Readiness by providing:

- better trained reservists;
- real time fleet support, training and information exchange;
- a more cost effective method of training and providing support;
- a more responsive method of managing Reservist's travel orders and managing requests for support from the Fleet.

Some examples of how this technology will be used offer some perspective on the depth of the behavioral change that is required in order to capitalize on the capabilities of the network. Without the behavioral change the network will be underutilized. The examples also show how the effective use of the network will improve readiness and help to make the reservist a better asset to the fleet.

- By implementing a WAN that is IT-21 compliant, Reservists will become familiar with current Navy systems and it will be easier to establish a direct link between the Active and Reserve Navy.
- E-mail and Web Access to information will provide a convenient method of disseminating information. This is a critical tool to keep Reservists current with the Active Navy between monthly drills.
- Video Tele-Conferencing/Training (VTT) will bring training directly to the Reservist rather than accruing excessive travel costs.
- Business practices can be revised to support an on-line paperless environment. Annual training and weekend training applications, travel claims, recall bill, performance appraisals, etc. could be completed via a web server or e-mail.

Not only is a Naval Reserve WAN a fundamental element of our national defense strategy, but it will establish a more productive and responsive business environment for the Navy. Future training and support cannot succeed without the establishment of an IT infrastructure or without a dramatic change in the way that the Naval Reserve meets its mission requirements. The vast majority of the personnel in the reserve will need to change the way that they are meeting mission requirements by interacting with the network, thereby fully using the capabilities of the network. Steps need to be taken in tandem with implementing the network in order to reduce the time required to change procedures by which tasks are completed, reduce resistance to change and to gain the most benefit from the network.

## C. RESEARCH QUESTIONS

The main research question is to identify and recommend a standardized Reserve Center Local Area Network (LAN) architecture that is based on DON CIO's guidance on standardization and that will meet the requirements of the Naval Reserve. The design needs to consider the limited network experience of the Naval Reserve's Echelon V commands, the Infrastructure Plan 2000, and the upcoming release of Windows® 2000 operating system. Promulgating a template will help to ensure standardization as well as improving the overall performance of Reserve Center LANs. The template will diagram the network architecture, system components, desired functionality and logical relationship among components.

Additional questions addressed include:

- What impact will the network have on the organization and what strategy is needed to best manage the implementation?
- What are the challenges in implementing an effective Naval Reserve Force WAN?
- What are the challenges in managing a Naval Reserve Center LAN?
- What additional resources are needed to establish an efficient and effective LAN?
- What should the Reserve Center LAN be used for in order to provide the most benefit to the Navy?
- What are the immediate and long-term network requirements of the Naval Reserve Force?

## **D. SCOPE**

The scope of this thesis includes: (1) a description of the Naval Reserve Force organizational structure; (2) a summary of Infrastructure Plan 2000; (3) an overview of network technology and design fundamentals; (4) an analysis of the network requirements of the Naval Reserve; (5) a recommendation and rationale for acceptance of a standardized network infrastructure; and (6) a analysis and recommended strategy for managing the implementation.

## **E. METHODOLOGY**

A review of various networking publications, periodicals, and commercial and DOD on-line resources was conducted. An analysis of the requirements and the challenges of establishing and managing a Reserve Center LAN was completed through a review of a survey, participation in a Naval Reserve Force IT Summit, site visits and informal discussions with network administrators. This helped in identifying required resources, implementation challenges, and areas where assistance is needed. The information obtained was used to develop a recommendation for a LAN architecture that is tailored to the specific needs and constraints of the Naval Reserve Force.

## **II. NETWORKS OVERVIEW**

An introduction to the fundamental concepts of networks and the associated terminology is needed as a framework for understanding the concepts of network architecture, design and implementation. The information presented is relevant to all Naval Reserve Centers and will provide a general knowledge base of the technology used and of the benefits of implementing a LAN. Sources of additional information will be included for further study. This chapter will form the foundation for guidelines on designing, implementing and administering a Naval Reserve Center LAN.

### **A. NETWORKS**

A network is "a group of computers and various devices (such as printers and routers) that are joined together on a common network medium" [Ref. Chellis, 1997]. The primary reason for implementing a network is to share resources and files. Networks can be categorized, based on size, as either a Local Area Network (LAN), Metropolitan Area Network (MAN), or a Wide Area Network (WAN). This paper will focus on LAN technology from the perspective of a LAN Administrator. A LAN is a group of interconnected computers located within close proximity of each other, such as at a Naval Reserve Center. A LAN is often contained within one building, however, it has the capacity to operate amongst several buildings located in the same physical area. A WAN is a group of LANs that are interconnected across a large geographic area. The Naval

Reserve's plan is to implement a WAN comprised of all Naval Reserve Force commands which includes over 150 Naval Reserve Centers. This will significantly improve communications within the Naval Reserve as well as with the Active Navy. This is an important aspect of ongoing efforts to create a seamless link between the Reserve and Active Navy.

A LAN can be implemented as either a peer-to-peer, client-server or a hybrid network. There are several factors that need to be considered when deciding which category to implement. These factors include the number of users the network will support, budget, security and management requirements, and the purpose of the network.

#### **1. Peer-to-Peer Networks**

In a peer network each workstation serves as both a client and a server. Each workstation functions independently in its administration and operation. The concept is to empower the user to decide what resources to share with the rest of the users on the network. Peer networks are typically implemented when the network will consist of ten or fewer components, no centralized control is needed and security is not a priority.

A peer network provides a good solution when funds are limited and ease of implementation is needed. It is an easy way to share resources and doesn't require as much training and technical background as a client-server network does to administer. This type of solution would work well for a Reserve Center that is implementing a small LAN or to set up a computer lab for user training and the support of unit administrative requirements.

## **2. Client-Server Networks**

Client-Server networks use one or more dedicated servers to provide centralized management and support of the clients attached to the network. A server is a computer that has been optimized to provide support services to other computers. Services provided vary depending on how the server is configured. Examples of services provided include: validating user logons, maintaining directory database, storing data, network security, file and print services. A client-server network is well suited for the typical Reserve Center that will be connected to the Naval Reserve WAN. This configuration provides significant advantages over a peer network but at an additional cost in terms of network components and administration. The most notable advantages over a peer network include: centralized management and backup, easy expandability, increased efficiency in sharing expensive resources (e.g. high quality output laser printer) and increased security. The degree of security provided and method of implementation is significantly different when compared to a peer network. Consequently, the network administrator must have more training and experience in order to effectively manage the network.

## **3. Hybrid Networks**

A hybrid network is best described as "a client-server network that also has peers sharing resources. Most networks are actually hybrid networks." [Ref. Chellis, 1997] Hybrid network is a combination of both a peer network and a client-server network. It offers greater flexibility and the advantages of both types of networks.

## B. NETWORK TOPOLOGY

Topology refers to the physical layout of the network. The physical layout or general shape of the network can best be described as the way in which the network components are interconnected. The four most commonly used LAN topologies are bus, star, ring and mesh.

### 1. Bus Topology

A network topology is one in which all computers are connected by a single length of cabling with a terminator at each end. The bus is the simplest and most widely used network design [Ref. Chellis, 1997]. Figure 2-1 illustrates the configuration of a bus Topology. Computers are connected to branches that run off the main cable (backbone).

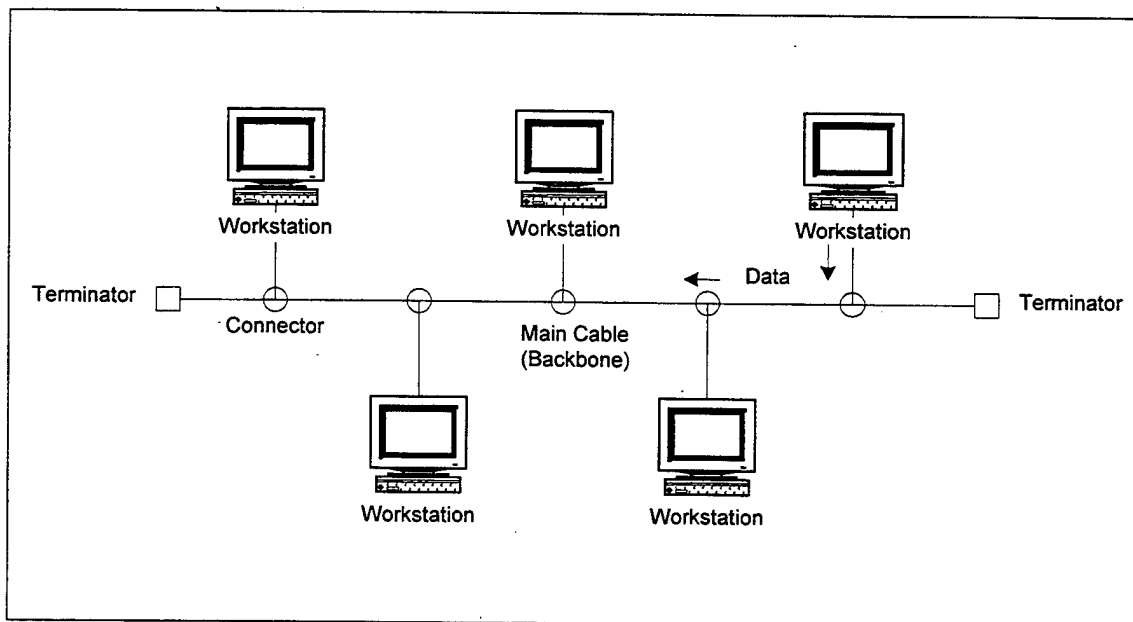

Figure 2-1. Bus Topology.

In order to transmit data, a computer first listens to ensure that no data is being broadcasted, then sends the data along the backbone to all computers on the network. Each computer checks the address contained in the data and accepts the data if the address matches. Terminators are needed at the ends of the cable to absorb signals that reach the end of the wire. Without terminators reflections will occur that will prevent the network from functioning effectively. Connectors are needed to connect branches to the backbone and workstations or other peripheral devices to the branches. Due to the resistance in the cable and the connectors, the strength of the signal decreases as it travels down the cable. Therefore, the length of the cable has an effective limit which varies depending on the type of cable used.

The bus topology provides a simple and inexpensive solution for a small network. The disadvantage is that it is not as scalable as other topologies; it is harder to troubleshoot and it can become burdened with network traffic as more computers are added.

## **2. Star Topology**

In a star topology, "all of the cables run from the computers to a central location, where they are all connected by a device called a hub" [Ref. Chellis, 1997]. Figure 2-2 illustrates the configuration of a Star Topology. The hub serves as a central point for the workstations to transmit data through to the ultimate destination of the data.

There are three main types of hubs available: passive, active or a switched hub. They also vary in the number of ports on the hub (e.g. 4,8,16,24 or 48 port hub).

“An active hub regenerates the electrical signal and sends it to all the computers connected to it. This type of hub is often called a multiport repeater. Active hubs and switches require electrical power to run. A passive hub, such as wiring panels or punch-down blocks, merely acts as a connection point and does not amplify or regenerate the signal. Passive hubs do not require electrical power to run.” [Chellis, 1997] The active hub provides the advantage of regenerating the signal thereby extending the distance of the network.

A switched hub significantly improves the capacity (bandwidth) of the network. This is accomplished by using electronic switches to direct the data directly from the sending computer via the switched hub. The end result is an increase in capacity due to the capability of having multiple computers sending data at the same time. In effect, each computer attached to a port on the switch is its own independent segment.

The star topology is easy to expand and provides for centralized management. Multiple hubs can be interconnected to expand the size of the LAN, to provide fault tolerance and to overcome the distance limitations of cable. A failure with one individual station in a star topology will not affect the integrity of the network itself. The disadvantage of this topology is that the failure of the main hub can bring down the whole network and it requires more cabling than other options. However, in general, this topology offers a good solution for use by Reserve Centers because of its expandability, centralized management and it is relatively easy to troubleshoot.

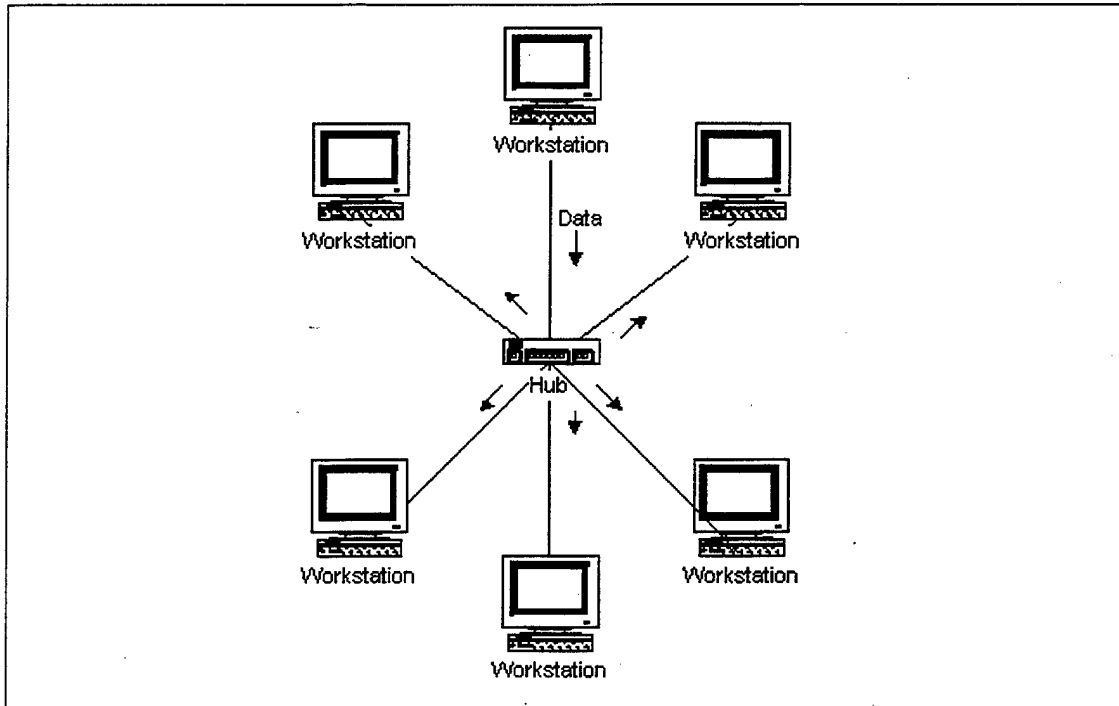

**Figure 2-2.** Star Topology.

### **3. Ring Topology**

A ring topology is constructed by connecting all workstations in a circle with segments of cabling. Each workstation is connected to two other workstations, one on each side. Figure 2-3 illustrates the configuration of a ring topology. This offers improved performance because each segment is impacted by only traffic between two workstations. Data is transmitted by passing the signal from the source through each intermediary workstation on the ring until the data reaches its ultimate destination.

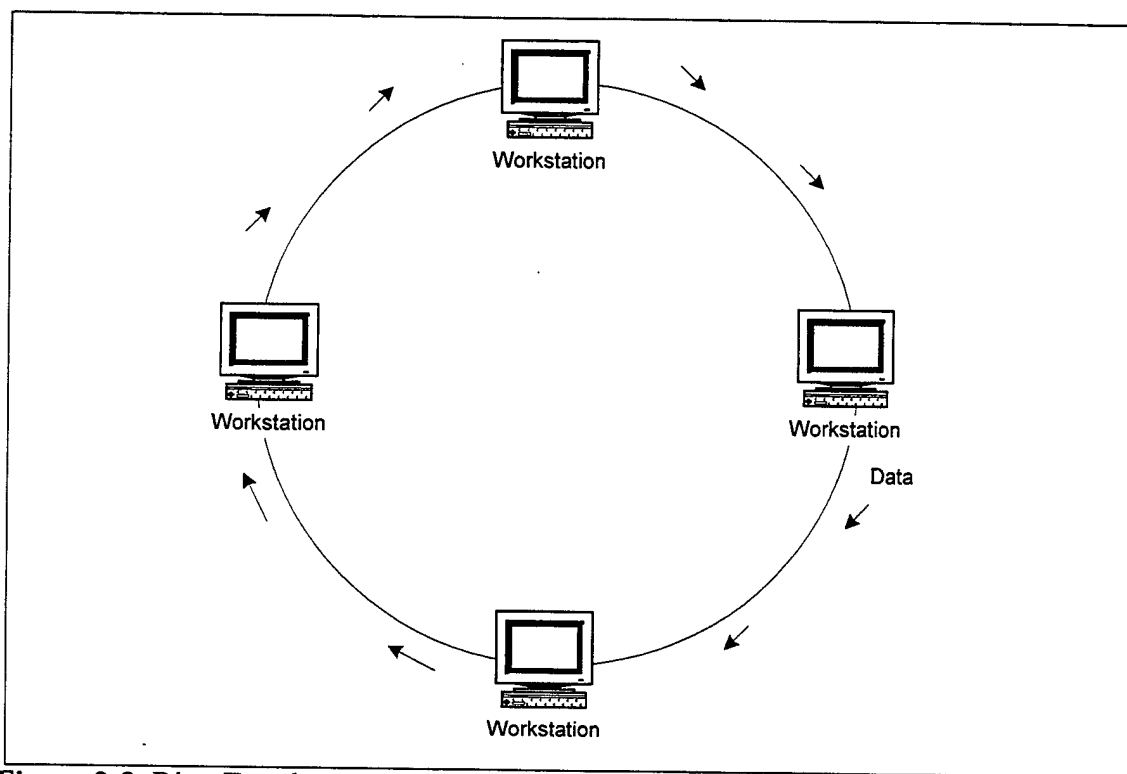

**Figure 2-3. Ring Topology.**

#### **4. Star Bus and Star Ring**

Frequently networks are implemented by using a combination of topologies. A bus configuration can be used to interconnect several hubs (star bus topology). This is done to provide fault tolerance and extend the distance of the network. A star ring topology uses a hub that is designed to work like a ring topology. The main reason for using this device is to make it easier to install and implement a ring topology. The network can be expanded by adding additional hubs to the central hub.

#### **5. Mesh Topology**

A mesh topology is used in situations which require a great deal of fault tolerance. The concept is to connect all computers on the network via multiple paths. The redundant

connections provide an alternate path for the data in the event of a cable failure. By design, every computer will have one link to all computers on the network. As the number of computers on the network grows, the number of connections and amount of cable required for implementation grows rapidly. This topology is more costly in terms of cable, installation and maintenance, and it becomes difficult in the event of a failure to isolate the problem.

Table 2-1 provides a summary comparison of the advantages and disadvantages of the primary topologies that are available for consideration when designing a network.

Topology	Advantages	Disadvantages
Bus	<ul style="list-style-type: none"> <li>- fast and simple to implement</li> <li>- requires less cable than other topologies</li> </ul>	<ul style="list-style-type: none"> <li>- difficult to isolate problems</li> <li>- a problem in the main cable can affect the entire network</li> </ul>
Star	<ul style="list-style-type: none"> <li>- easy to modify, expand and troubleshoot</li> <li>- centralized management</li> <li>- single computer failure doesn't affect the whole network</li> </ul>	<ul style="list-style-type: none"> <li>- central hub fails, the whole network fails</li> <li>- requires more cable, therefore increased cost</li> </ul>
Ring	<ul style="list-style-type: none"> <li>- provides equitable access to all users</li> <li>- provides good performance</li> </ul>	<ul style="list-style-type: none"> <li>- a problem with one station can affect the entire network</li> </ul>
Mesh	<ul style="list-style-type: none"> <li>- high fault tolerance</li> </ul>	<ul style="list-style-type: none"> <li>- more difficult to install</li> <li>- more costly to install and maintain</li> </ul>

**Table 2-1.** Topology Summary Comparison.

### **C. NETWORK MEDIA**

Network media is an essential element of network communications and refers to the medium used to transmit data. Transmission media can sometimes take the form of wireless technology, but cabling is more prevalent. There are significant differences in

the characteristics of the various media types and these need to be taken into account when designing a network. The following sections cover the main types of media available for use in implementing a LAN and their varied characteristics.

### **1. Twisted-Pair Cable**

Twisted-Pair (T-P) cable is constructed of two to four pairs of wires that are twisted together. Phone wire is an example of T-P cable. The twisting of the wires helps to reduce the amount of attenuation - signal loss due to interference. The greater the number of twists per foot the less the signal loss will be. T-P cable is available in two types: Unshielded (UTP) and Shielded (STP). STP is more expensive and provides more protection against interference by covering the wires with a shielding.

There are five distinct categories of T-P cabling available: Cat 1, Cat 2, Cat 3, Cat 4 and Cat 5. Table 2-2 provides a summary comparison of the various categories. Cat 1 is not suitable for data transmission, Cat 2 through 5 are found in older networks (primarily Cat 3 & 5). Cat 5 enhanced cabling is what is commonly being used in constructing new LANs. Naval Reserve Center LANs need to be cabled with Cat 5 Enhanced cable in order to be compliant with IT-21 standards. Consideration also needs to be given as to whether plenum grade cable is required. Plenum cable is fire-resistant but more costly. Fire code requires that plenum grade cable be used in crawl space areas such as the area above false ceiling tiles.

UTP/STP Category	Transmission Rate	Application
Cat 1	Voice Only	phone only - not suitable for data
Cat 2	4 Mbps	outdated technology - no longer used
Cat 3	10 Mbps	meets the minimum IEEE 802.3 standards - found in older networks
Cat 4	16 Mbps	found in older networks
Cat 5	100 Mbps	commonly used in networks
Cat 5 E	100 Mbps	recommended for new networks - enhanced version of Cat 5 - provides additional performance guarantees.
Cat 6	250 Mbps	currently available, however, IEEE 802.3 standards haven't been finalized
Cat 7	600 Mbps	IEEE 802.3 standards are in development

**Table 2-2.** Twisted-Pair Cable Summary Comparison.

## **2. Coaxial Cable**

Coaxial cable is an older technology that was used extensively and is still commonly found in established networks. Coaxial cable is constructed of a single wire conductor that is covered in three layers - insulation, metal braided conductor, and a protective jacket. An example of coaxial cable is TV cable. Data is transferred along the single wire and the braided conductor provides shielding from interference. There are two categories of coaxial cable: thicknet (10Base5) and thinnet(10Base2). Thicknet typically serves as a backbone and thinnet is used for segments off the backbone in a bus topology. Coaxial cable is relatively inexpensive, not as flexible, and more likely to have network problems due to loose connectors.

Several sites within the Naval Reserve Force are currently using a combination of both thicknet (backbone) and thinnet. This type of cabling is limited to locations that were among the first to be networked (older established LANs - primarily at Readiness

Commands). As funding becomes available, they are migrating to Cat 5 Enhanced cable which is the current standard.

### **3. Fiber-Optic Cable**

The principles of operation and characteristics of fiber optics are significantly different than a metallic transmission medium (typically copper). Copper cable transfers information in the form of transverse electromagnetic waves whereas fiber cable transmits information in the form of light. Fiber optics has many advantages over metallic mediums and has numerous applications. It is an excellent choice for high-speed, high-capacity information transmission because of the lack of attenuation (signal loss due to distance traveled) and integrity of the signal. Fiber optics is used in several different industries, including telecommunications, medical, military, industrial and automotive.

Telecommunication fiber can be classified as either single-mode (8.3um) or multi-mode fiber (50um or 62.5um). These two modes vary in operation, characteristics and application.

Single-mode fiber is best suited for applications that require a long distance and/or a high data rate (wide bandwidth). The core size is small enough to support only one mode of light to propagate down the path and a laser is used to generate the light (Figure 2-4). The small core of the fiber keeps the light signal from bouncing across the diameter of the core of the fiber. This design keeps the signal loss to a minimum, increases the data rate and the distance the signal can transmit. The drawback is that the small core increases the cost of the system. The primary contributors to the increased cost

are the laser transmitter and the splicing and connecting of fiber with the associated components.

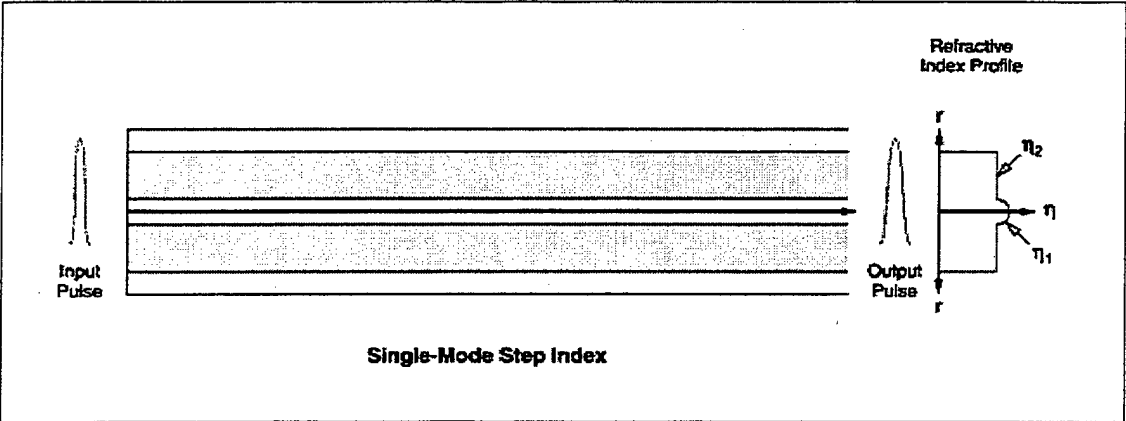

Figure 2-4. Single-mode Fiber [Ref. From Adams, 1999].

Multi-mode fiber is larger in size and supports multiple modes of light. The larger core size supports more than one mode of light (Figure 2-5). This increases the dispersion of the signal and the attenuation losses. Designed for shorter distances and lower bandwidth applications, it is best suited where the links are short and there are many connectors because multi-mode allows the use of a relatively inexpensive LED transmitter and low cost connectors.

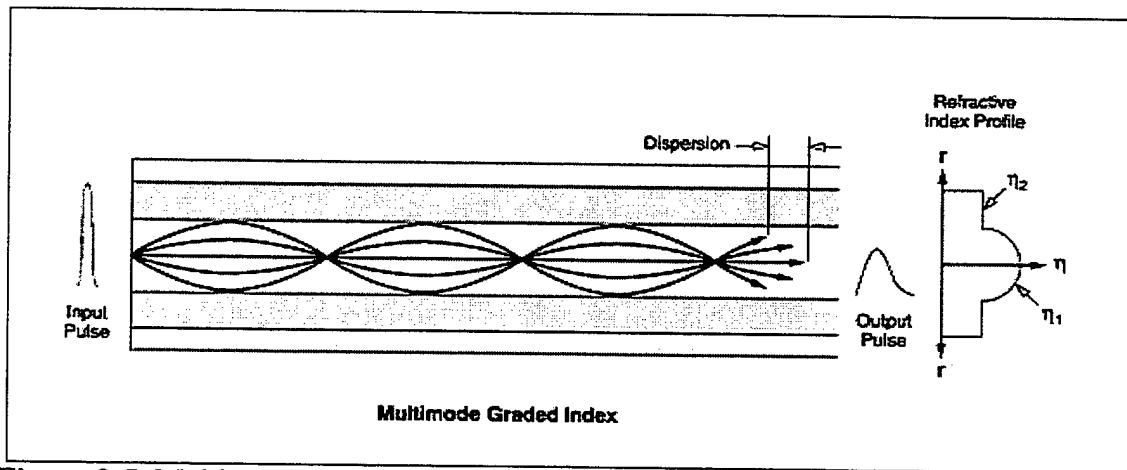

Figure 2-5. Multi-mode Fiber [Ref. From Adams, 199].

#### 4. Cable Selection Considerations

Deciding what type of cable to use depends on several factors including cost, bandwidth, security, distance between workstations and buildings, ease of installation, susceptibility to interference and consideration of future network expansion. The cost of purchasing and installing cable can often be the overriding factor due to budgetary constraints. Keep in mind that the actual cost should also consider any necessary interface components, repeaters or other additional equipment that may be needed. You may have to spend a little more up front, but could avoid additional costs in the future by installing cable with enough bandwidth to handle future requirements as the network utilization increases and grows in size. Table 2-3 provides a summary of some of the specifications and characteristics that should be considered when deciding whether to use fiber or copper.

Cable Media	Capacity	Attenuation	Distance	Interference	Cost
UTP-Copper Cable	1-155 Mbps	High	100s of Meters	Most vulnerable to EMI and Tapping	Lowest
STP-Copper Cable	1-155 Mbps	High	100s of Meters	Less vulnerable to EMI and Tapping	Moderate
Coaxial Cable	1-10 Mbps	Lower	A few Kms	Less vulnerable to EMI and Tapping	Moderate
Multi-Mode Fiber	2 Gbps	Lowest	2 Kms	Not affected by EMI or Tapping	Higher
Single-Mode Fiber	Limited by Hardware	Lowest	62Kms +	Not affected by EMI or Tapping	Highest

**Table 2-3.** Cable Specifications Summary.

#### **D. NETWORKS OVERVIEW SUMMARY**

The information presented in this chapter provides the fundamentals that are needed in order to go forward with designing and implementing a network that will be suited to the unique characteristics of an individual Naval Reserve Center. A client-server network that is implemented utilizing Cat 5 enhanced cabling and a star topology is well suited to the needs of the Naval Reserve. This approach would offer centralized management, security, the ability to share resources, sufficient bandwidth, and scalability as well as compliance with DON CIO Information Technology Standards Guidance (ITSG). Appendix A provides a list of DOD and non-DOD sources of more detailed information on networks.

THIS PAGE INTENTIONALLY LEFT BLANK

### III. LAN DESIGN FUNDAMENTALS

A basic understanding of the concepts of network design is needed in order to design and implement an efficient and effective Naval Reserve Center LAN. Designing a network is a complex task that involves detailed planning and decision making. Detailed planning is necessary to ensure that the network will be installed with minimal difficulty and will meet present and future needs as well as budgetary constraints. The network design process is an unstructured decision problem that involves several steps. Each step in the design process requires key decisions to be made which will affect the performance, efficiency, expandability and the overall cost of the network. Making these decisions can be difficult for someone who does not have a clear understanding of the vast array of available network technology. Designing a large system can be a challenge even for the most experienced network designers due to the complexity of the problem, the number of alternatives that are available and the rate at which technology is advancing.

Before the design process can begin, you need to identify key individuals to be assigned to the planning and design team. The composition of the design team will be an important element in how smoothly the process goes and will impact the quality of the end product. The team will be responsible for coming up with an effective design and installation plan. This will help to ensure that scarce funding is well spent, the end result meets user expectations and that future expansion will be taken into consideration.

The size of the team will vary depending on the scope of the design. The Naval Reserve Center Commanding Officer or Command Chief should be a part of the team. This helps to ensure command buy-in to the design and to ensure management's goals are taken into consideration. It is equally important to get the users of the network involved in order to identify their needs. Also, take the time to identify key members of the Selected Reserve who may have expertise in this area from their civilian jobs. Given today's technological society, it is likely that there are reservists who are assigned to the center who have experience as network administrators or in network design and installation. Construction Battalions are another good source of manpower to assist with cable installation. Be sure to capitalize on the experience gained by other centers in the area that may have completed similar projects. It is a good idea to travel to other centers to see how they have implemented their network and to take advantage of the insight they have gained. Forming a good design team will help to ensure that the end product meets user expectations and will improve the overall quality of the LAN.

The following sections will take a look at some of the issues and the steps that should be followed in designing a center LAN. The network needs to be designed based a standard network architecture provided by CNRF and a analysis of local requirements to ensure that the needs of the end users are met. There are many similarities among reserve centers so the information presented will serve as a good starting point for designing or expanding a reserve center LAN. However, keep in mind that each reserve center will have unique challenges and requirements that need to be addressed. This is intended to

provide a design framework for use in identifying and addressing the specifics of individual centers.

The primary steps to designing a network are the needs analysis, site analysis, equipment matching, configuration plan, server directory structure, configuration lists, installation schedule and system log. These steps are intended to serve as a general network planning process. Some steps will have more relevance than others and consequently should be completed in greater detail. It is intended to be customized to whatever extent is needed to meet the specifics of individual centers. [Ref. Thomas, 1997]

#### **A. NEEDS ANALYSIS**

The first and most important step is to conduct a needs analysis. A thorough needs analysis involves a fair amount of effort, but will pay big dividends in the end product. If the needs analysis is flawed, typically there will be costly added expenses to correct the design error. Informational interviews with the users will be an important aspect of the process. The needs analysis centers around identifying organizational issues that a network can effectively address and then translating those issues into goals. Special consideration needs to be taken as to the impact that decisions will have on future network expansion.

The following identifies the requirements that a typical Reserve Center has in order to meet mission requirements, provide contributory support to gaining commands

and to have a viable training program that will lead to improved readiness. The majority of the requirements identified are relevant to all centers, however, each center will have to review the particularities of its own organization in order to ensure that all requirements have been identified. It is also important to recognize that some of the requirements need to be met in the near term while others are identified in consideration of the future expansion of the network. The near term requirements are those that will provide immediate benefits and will form the foundation needed to support more advanced IT solutions.

**1. Compliance with DON Information Technology Standards Guidance (ITSG)**

The network must be designed to comply with DON ITSG in order to provide a standard architecture which is needed to maximize interoperability. Independent efforts to implement a LAN results in a variety of implementations that may work well locally, but doesn't necessarily work well when the LANs are interconnected to form a WAN. Compliance will help to reduce the cost associated with training support personnel who rotate every three years and support the establishment of a Naval Reserve WAN thereby creating an effective link with the Active Navy. The Naval Reserve's long range plan is to become a subscriber to the Navy and Marine Corps Intranet service. The use of current technology that is compliant with DON ITSG will offer the best chance for integration without having to replace the infrastructure that is currently being established.

## **2. E-mail Connectivity**

Currently reserve centers are using an application called GroupWise for e-mail. This scheme requires an operator to dial a 1-800 number via modem to download e-mail from a mail server located in New Orleans or at the readiness command and managed by Naval Reserve Information Systems Office (NAVRISO). Drawbacks to this method include: slow downloading; e-mail is not real-time; command is limited to two accounts, inefficient and frustrating to use.

Email connectivity via a networked mail server would allow all of the staff and any of the reservists with an e-mail and NT account to receive, access, and send e-mail from their workstation in the center in real time. Reliable e-mail is especially critical in the reserve community because of the nature of the mission and organization structure. Additionally, this will support the center commanding officer to more easily communicate with the staff, the reservists and higher headquarters.

An effective e-mail system would significantly improve both FTS and SELRES communication as well as reduce the amount of time needed to complete administrative requirements. E-mail provides an efficient way of passing along information, both within and outside the command. It would also support communication with the Active Navy thus contributing to the Reserves ability to provide prompt support.

## **3. Internet/WWW Connectivity**

This is an increasingly important capability. There is a limited flow of information to individual reservists to keep them current on administrative and operational matters, as

compared to their active duty counterpart. Web connectivity provides an excellent method of providing access to current data. There are numerous resources available online, such as: command web sites; publications; forms; security and other software; and other DOD related material. Access to these resources will have a positive impact on the ability of the staff to complete their mission efficiently.

#### **4. Sharing of Peripherals**

This is an important component of office automation, and can go a long way in terms of increasing productivity. For example, the typical center has one high output quality printer that needs to be made available for use by all center personnel. A LAN will allow sharing of this device and allow access to additional peripherals as they are added to the network.

#### **5. Centralized File Service**

A centralized file service is needed to provide a convenient method of backing up files created by users. This will save time and help to ensure data is protected by providing centralized backup of files.

#### **6. Network Security**

When designing a network it is important to give careful consideration as to the security requirements of the organization. Keep in mind that a client-server network offers several advantages over a peer network in terms of built in security functions. Space and Naval Warfare Systems Command has developed a configuration guide for securing the Windows NT operating system. The guide provides detailed configuration

procedures as well as identifying other considerations that should be taken into account. Appendix A provides the web address where the source document can be downloaded as well as other useful security related sites.

#### **7. Network Training**

Network Administration training is needed for the system administrator as well as general training for all system users. An effective training program would serve to assist all personnel in fully utilizing the resources of the computer network as well as to help maintain good security. A required skill set needs to be identified which would reflect the minimum computer skills needed to fulfill the various job assignments in the Naval Reserve.

#### **8. Computer Lab**

A computer lab would provide benefit to a reserve center in a multitude of ways. It would provide an excellent resource for units to use to complete administrative requirements. The computers in the lab would be installed with Microsoft Office Suite as well as programs that are specific to the needs of the Naval Reserve (e.g. performance evaluation, physical fitness report). The lab would provide further benefit by serving as an excellent resource for conducting training on software applications and general computer training.

#### **9. Video Tele-Conferencing/Training(VTC/VTT)**

VTC/VTT capability could be used to reduce the cost associated with traveling to training and conferences. Current training could be brought direct to the center instead of

incurring costly travel expenses and wasting reservists limited drill time. Also, the capability could be used to conduct active duty gaining command and reserve unit meetings thus improving communications.

#### **10. Document the Current Network and the Vision for the Future**

It is very important to fully document the network. Reserve staff members typically transfer every three years. Details of how the network was implemented need to be documented for future reference by the current network administrator as well for use by his relief. This becomes particularly valuable for troubleshooting network media problems. A static diagram is needed to show the current layout of the network and where the cable was run. It is also helpful for planning of the future growth of the network and use in directing work on the network.

There are several network design tools that are available that can provide substantial benefit with this step of the process. In reviewing the needs of the Naval Reserve and the capabilities of the major design tools that are available, it is recommended that the Naval Reserve use Visio Professional for network diagramming . It is widely used by network design professionals and is well suited to the particular needs of the Naval Reserve. Appendix B provides an overview of what network design tools are and how they can benefit the Naval Reserve. Also, a comparison of three widely used design tools and justification as to why Visio Professional is the right tool for the Naval Reserve's network design and diagramming needs.

## **B. SITE ASSESSMENT**

This step involves an assessment of the current system, building(s) layout, special requirements, etc. The purpose of this phase is to collect data that will be needed to develop a list of materials and to organize the network in a logical manner. Additionally, to identify obstructions to installing the network and to help to better visualize the scope of the job. The assessment needs to include a drawing that reflects the location of electrical outlets, immovable obstructions, furniture, computer equipment, doors and windows, and building and work spaces dimensions. This drawing will prove very useful in determining an accurate estimate of the amount of cable needed and ensuring that cable runs are within the prescribed limits. The assessment needs to include a review of available equipment to determine what will be included in the network and how it can be incorporated to the best advantage.

## **C. EQUIPMENT INVENTORY/MATCHING**

The command Controlled Equipment Inventory System (CEIS) inventory is a good place to start when compiling a list of available equipment and features. Examples of the type of information that should be included are: processor, RAM and hard disk size; monitor, floppy disk and CD-ROM specifications; serial numbers; warranty information; etc. The CEIS inventory program is limited in its ability to store additional information. The Naval Reserve should consider purchasing an inventory program designed for networks or designing one that addresses the needs of the reserve using

Microsoft Access. It is useful to have this information when making decisions on how to best use the equipment that is available and in identifying what equipment should be phased out.

#### **D. CONFIGURATION PLAN**

This step involves identifying hardware, components, a list of materials, cost estimation and design of the physical layout of the system. Also, expanding the drawing from the site assessment phase to include where the cable will be run and where all network related components will be located. A better system can developed by keeping the following in mind: balance present and future needs; obtain all system components from one vendor; include training costs; and consider using a consultant and/or network modeling and simulation tools.

It is important to be able to provide justification to management as to the benefits of the network. A detailed network design, performance estimates, bill of materials, and a cost estimate will help with this step. Management's support is needed to obtain the necessary funding!

#### **E. SERVER DIRECTORY STRUCTURE**

A directory structure is a set of named logical addresses that are used to organize related files on the server's hard drive into a logical order that makes them easier to find. The structure of the directory can vary considerably from one server to another depending on the server's functions and individual preferences.

## **F. IMPLEMENTATION SCHEDULE**

It is a good idea to develop a schedule for the installation of the network. This will help to visualize the steps in the process, time required for implementation, identify who will be involved in the project and to identify possible conflicts with other scheduled work.

## **G. SYSTEM LOG**

The system log is a collection of information on the components that make up the network. It will include network diagrams, equipment inventory and related information, details on how the server was setup, trouble reports, repairs, backup plan and log, etc. This information provides a history of the network and is valuable for troubleshooting, managing the network and in briefing newly assigned network support personnel.

## **H. LAN DESIGN SUMMARY**

The framework for designing a local area network that was identified and described in this chapter will prove useful in successfully designing and implementing a LAN. A network design tool such as Visio Professional will help to make the design process an easier one and will provide substantial benefits by providing a tool for documenting the network and for developing a network architecture. The network architecture will serve to provide the foundation for a standard network infrastructure and will provide a vision of what the network will look like in the future.

Designing a network is clearly a complex task that requires detailed planning and involves making many decisions along the way. The Naval Reserve needs to develop a detailed network implementation plan and effectively communicating the plan is critical to the successful establishment of a cost-effective WAN and LANs at the centers. A defined LAN and WAN architecture that reflects the requirements of the Naval Reserve will prove to be useful in attaining this goal.

#### IV. RESERVE CENTER LAN ARCHITECTURE

The purpose of this chapter is to provide recommendations for a standard architecture to be adopted by CNRF in the implementation of a Windows NT LAN at the reserve center level. The architecture design is based on a review of DON CIO's guidance on standardization, a requirements analysis of Naval Reserve activities, and with careful consideration of future requirements. Sufficient details on the architecture are provided to support network planning, design and implementation at Naval Reserve Force activities. Diagrams are included that show the recommended network topology, components and their functional relationship. The recommendations are limited in scope and are intended as an input for consideration by CNRF in the development of detailed guidelines on a standard network infrastructure.

A network architecture is that portion of the IT infrastructure that specifies the desired structure of the enterprises' network. Its purpose is to provide an organization with a framework for more informed decision-making and a guide for ongoing planning, design and implementation. It includes some specification of standards, distribution of system functions and how the components relate to one another. A template is the mechanism used to depict the network topology, the relationship between components and the distribution of functionality. It provides a blueprint that is useful in helping to visualize the structure of the network. [Ref. Passmore, 1997]

A standard architecture is critical to the establishment of the Naval Reserve Network (NAVRESNET). The architecture's main purpose is to provide guidance and structure for implementing the network. It serves to define the Naval Reserve's information technology strategy. A uniform strategy is needed to insure that all LANs are implemented with a similar approach. This will help to ensure that reserve center LANs will function effectively when incorporated into the NAVRESNET. The LAN architecture is one part of the overall WAN network architecture.

To date, the Naval Reserve has not adopted a standardized network architecture and has provided minimal guidance on implementing reserve center LANs. This has resulted in a variety of approaches to implementing LANs at reserve activities that are located throughout the country. CNRF has begun the establishment of a frame relay architecture which will provide connectivity to all CNRF activities. Without a standard LAN architecture, it will be difficult to manage and connect the collection of disparate systems. A more uniform approach that conforms to published guidance on standardization, will result in a more viable network.

Figure 4-1 provides a recommendation for a LAN design for use by Naval Reserve activities and depicts the relationship of the network components. All CNRF activities must implement a similar architecture in order for them to function together effectively as part of the NAVRESNET. All equipment, components, servers, workstations and cabling must be selected with consideration of the guidance in the DON Information Technology Infrastructure Architecture (ITIA) and DON Information

Technology Standards Guidance (ITSG) documents. This will ensure that interoperability is maximized and will enable focused network support across the Naval Reserve. Figure 4-2 provides another view of the network with less detail.

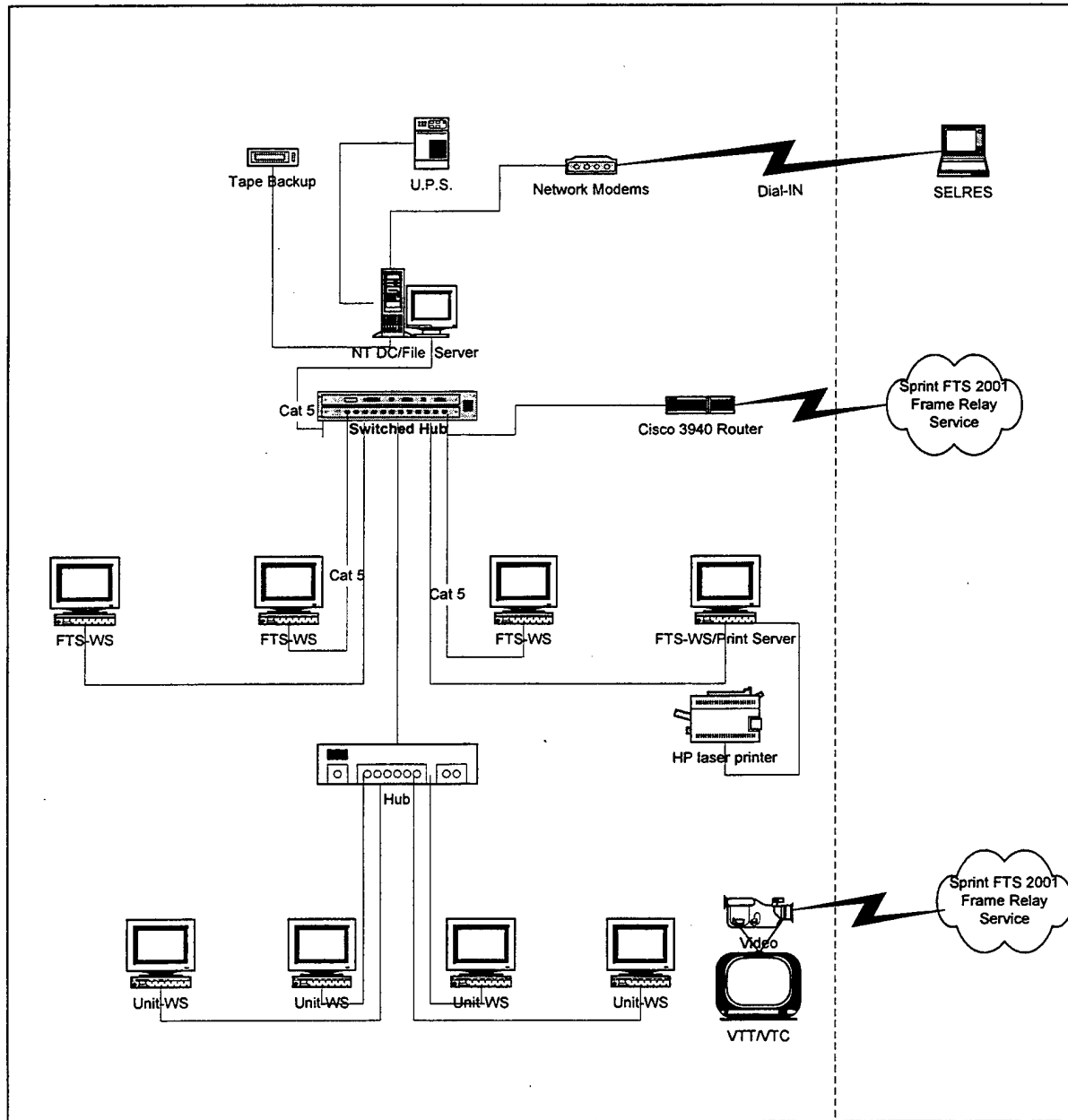

**Figure 4-1.** Naval Reserve Center LAN Design Template.

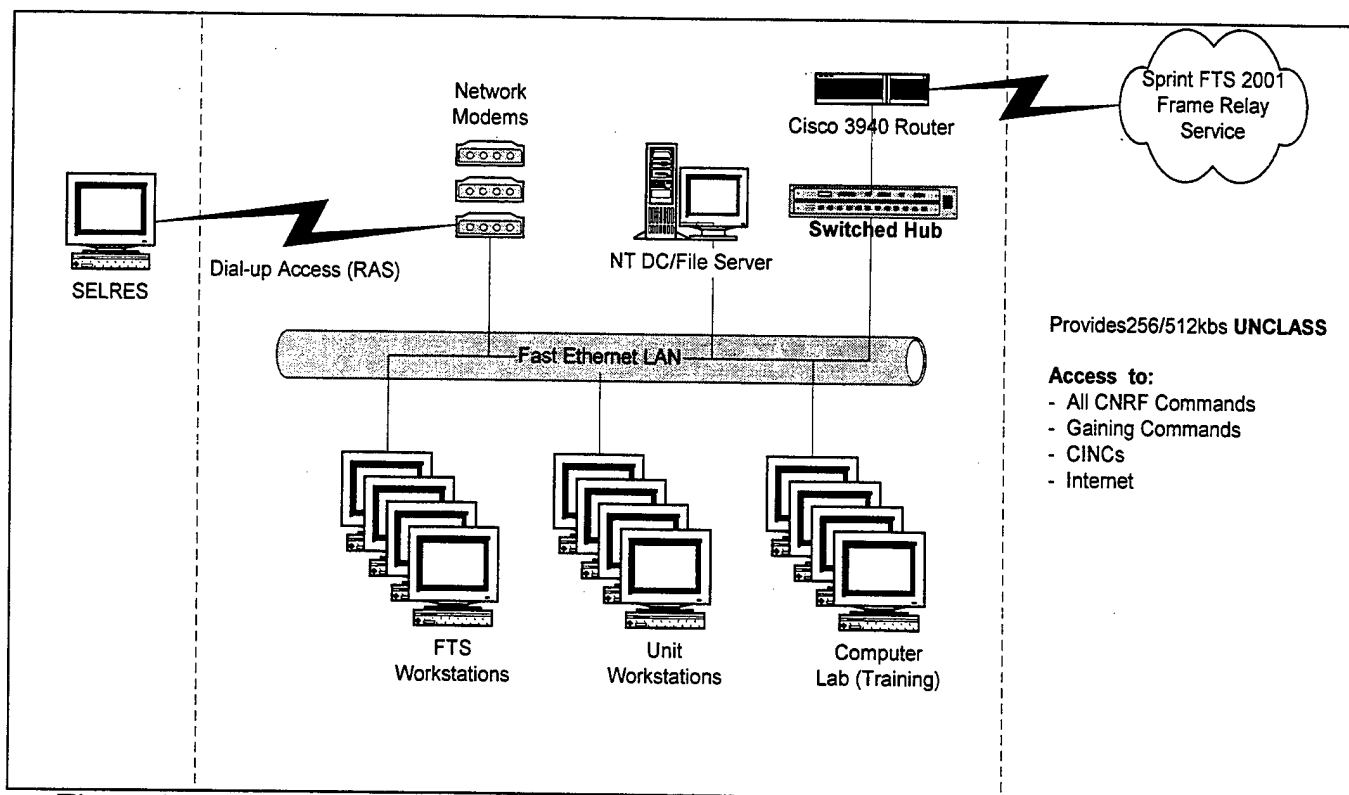

Figure 4-2. Naval Reserve Center LAN Design Template.

## A. ETHERNET

Ethernet is a widely used and well understood network technology. Due to the high demand for Ethernet, there are numerous vendors, a wide variety of equipment configured to support Ethernet and it is readily available at a competitive price. Ethernet is a local area network (LAN) technology that is used to transmit data between computers at speeds of 10 Mbps to 100 Mbps. Currently the most widely used version of Ethernet technology is the 10-Mbps twisted-pair category. Fast Ethernet (100 Mbps) is a more recent Ethernet standard which operates over twisted-pair and fiber optic media and has become the accepted standard. [Ref. Spurgeon, 1995]

Several technologies are available that could potentially be used to meet the Naval Reserve's requirements for data transmission. The ITSG limits the selection to one, or a combination, of the following four network technologies: Ethernet, Fast Ethernet, FDDI and ATM. It also includes background information on the technologies and discussion as to which applications each technology is most suited. Additionally the ITSG recommends taking a consistent LAN configuration approach throughout the domain. For example, mixing different protocols, different data transfer technologies or different network operating systems would not be recommended.

Based on a review of the ITSG and the Naval Reserve's requirements, all reserve center LANs should be implemented as a Fast Ethernet (100Base-T). This will provide a consistent approach and help to ensure that the network meets current needs as well as to support the future growth of the network. Fast Ethernet has sufficient bandwidth to support an increase in network traffic and advances in network technology. Table 4-1 provides a summary comparison of Ethernet Vs Fast Ethernet technology. Fast Ethernet is at the leading edge of Ethernet technology and offers significant advantages over 10 Mbps Ethernet. Implementation of Fast Ethernet will provide CNRF activities with a more responsive and uniform network environment.

<b>Technology</b>	<b>Advantages</b>	<b>Disadvantages</b>
Ethernet (10 Mbps)	Well understood Inexpensive Numerous vendors Strong commercial support Reliable multi-vendor interoperability Available in fiber version	Low throughput High latency Not scaleable as a backbone No fault tolerance No Quality of Service
Fast Ethernet (100 Mbps)	Moderate throughput Numerous vendors Strong commercial support Reliable multi-vendor interoperability Available in fiber version	Not scaleable as a backbone No fault tolerance No Quality of Service

**Table 4-1.** Ethernet Summary Comparison [Ref. DON CIO, ITSG, 1999].

## **B. CATEGORY 5 ENHANCED CABLE**

The ITSG supports the selection of copper cable, fiber optic cable, and wireless RF. Fiber optic cable is recommended for use in the backbone of the network and to major junction points (e.g. telecommunications closet), as a minimum. It is the preferred media for its high-capacity (100's of Mbps), future bandwidth potential (Gbps to Tbps), reliability, reduced susceptibility to Electromagnetic Interference and security. Properly tested Category 5 cable is recommended for use from the telecommunications closet to the desktop and when funding constraints prohibit the use of fiber. [Ref. DON CIO, ITSG, 1999].

The standard media for reserve center LAN applications should be Category 5 enhanced unshielded twisted-pair cable, with RJ-45 connectors. Any CNRF activities that are currently using coaxial, 10Base5, 10Base2, or Category 3 cable should upgrade to Category 5 cable as funding permits. ITSG recommends using Cat-5 cabling between the workstation and other network equipment under conditions that are comparable to those

of CNRF activities. Fiber Optic cable should be used in situations that require connecting segments located within buildings that are in the same vicinity.

When purchasing cable that will be used within a wall or ceiling space used for air return, ensure that the cable's outer jacket composition complies with National Fire Protection Association (NFPA) standards. Cable that complies with NFPA standards is called plenum cable and is more expensive than standard cable. ITSG also recommends that panduit, conduit, local breakout boxes, patch panels, racks and lockable closets be used to provide for a more secure, organized and flexible system that supports easier movement of equipment.

Cat-5 or 100BasetT cable uses two twisted pairs to carry signals, with an additional two pairs grounded to reduce interference. The Cat-5 cable specifications require the use of an RJ-45 connector and supports several pin-out standards. An RJ-45 connector appears similar to a telephone connector, except that it has 8 pins.

The pin-out configuration that is recommended by ITSG and commonly used is designated as EIA/TIA T586A. The configuration standard defines the order that the cable wires are connected to the RJ-45 connector. Each wire is color-coded. For example, there is a white wire with a green spot. This is referred to as white-green. Figure 4-3 provides a representation of the pin configuration. This serves as a useful reference when stripping and attaching cable to RJ-45 connectors.

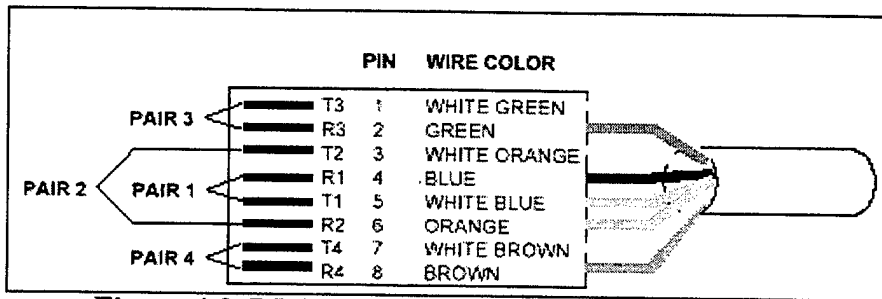

**Figure 4-3. RJ-45 Pin Specifications for T-568A.**

Some guidelines to follow for successful cable installation include:

- Limit the distance of cable runs to 100 meters.
- Ensure that the cable is properly labeled and tested after connecting RJ-45 connectors.
- Avoid excessively bending cable.
- Fast Ethernet is limited to two router hops.
- Do not run cables along the floor.
- Avoid electrical power sources, overhead junction boxes and lights. If you must pass near a light, the cable should cross perpendicular to the light.
- Use tie wraps in the ceilings to group and attach cables to solid items like tresses or girders. Do not pull the wraps tight, but instead use them to make loops through which the cable can be passed.
- End the cable run into a wall jack instead of directly into a workstation. This will reduce the stress on the wire. Patch cables are used to connect from the wall jack to the workstation.
- Use PVC conduit or panduit to provide for cable protection.

- Consider hiring a contractor or seeking help from reservists who may previous experience in cable installation.

### **C. NETWORK INTERFACE CARDS (NIC)**

An NIC card is an expansion board that, when installed into a computer, provides an interface between the computer and the LAN. When purchasing new computers, review the system specifications to ensure that it is equipped with an NIC. There are a wide range of NICs available. An NIC that supports auto-sensing 10/100 Mbps, with an RJ-45 connector is recommended for use with a Fast Ethernet LAN [Ref. DON CIO, ITSG, 1999]. The Naval Reserve should also consider using the same model NIC throughout the network. A network consisting of a variety of NICs would require multiple software drivers which results in a network that is harder to maintain. NICs already in place could be phased out over time as funding becomes available to purchase new NICs. The problems associated with supporting a wide range of NICs can be eliminated by moving towards a more uniform client environment.

### **D. HUBS**

A hub provides a means of centralizing connections, so that fewer connections actually run into the server. Ideally, only one connection will be run to the server. There are three main types of hubs available: passive, active or a switched hub. The type and number of hubs needed will vary depending on the number of users, the amount of traffic on the network and other factors. All activities will need a minimum of one hub to serve

as a connection point between the local server, workstations and the Cisco 3940 router. It would benefit the Naval Reserve to use a switched hub with a minimum of 24 ports for this particular application. A switched hub provides a significant performance improvement by having the ability to actually read the destination address of each packet and then forward the packet to the correct port. This provides the capability to divide the LAN into multiple segments with each segment being a separate collision domain. This will reduce the number of collisions thereby providing a greater effective bandwidth than other types of hubs.

Additional hubs can be used to simplify the network cabling and to increase the number of nodes on the network. This allows management of the distance limitation of Cat-5 cable and supports the optimal placement of the nodes in relation to the main hub. For example, consider installing an 8 port hub in an office rather than running 7 separate cable runs from the central hub. This will reduce the amount of cable needed and the labor involved. An active hub would work well for this particular application. When planning the network design, keep in mind that an active hub will need an electrical source to regenerate the signal.

The Naval Reserve should also consider centrally purchasing the switched hubs for use at CNRF activities. This will leverage purchasing power and provide for a more uniform network environment. Primary considerations when selecting a switched hub are to ensure that it is well suited for use with a Cisco 3940 router, and that it offers a variety of port densities and configuration options. The hub is the primary link between

workstations, therefore it is important to purchase a quality hub that meets the local requirements. The specific hub requirements of reserve centers will vary in terms of the number of ports needed and configuration options. For example, some centers may require a fiber optic link between a switched hub in building "A" to a router in building "B". Having the flexibility of adding a module to the hub could potentially avoid costs associated with a Cat-5 to Fiber media converter. Cisco offers a wide range of 10/100 autosensing Fast Ethernet switches that have the versatility to meet the unique network requirements of individual reserve centers.

#### **E. CISCO 3940 ROUTER**

A router is a device that is used to connect two or more networks. The Naval Reserve has established a contract to lease Cisco 3940 routers for use at all CNRF activities. The routers provide a means of interconnecting all CNRF LANs to form the Naval Reserve Network. Sprint FTS 2001 frame relay service will be used to provide a fiber optic backbone for connecting the routers and transmitting data between the LANs in a cost-effective and reliable manner.

Frame relay is a form of packet switching technology that uses statistical multiplexing over a shared network to connect multiple routers. The router is needed to forward the data packets from one LAN to another via the Sprint frame relay service. Each packet contains data and a header which includes the destination IP address. The router is able to read the IP address and compare it to the IP address and information

stored on the router table. Based on the information the router is able to determine the best route to forward the packet.

## **F. SERVER**

The DON ITSG recommends adopting the Windows NT server operating system for use throughout the enterprise. The guidance also suggests establishing an environment that is based on homogenous clients and heterogeneous servers. The workstations need to be uniform to provide a consistent user interface and to make system support and maintenance less complicated. The servers need to be based on a common operating system; however, their configuration and computing power will vary depending on the application of the server. When multiple servers are being used for similar applications a homogenous approach should be used to capitalize on the advantages of a homogenous environment. [Ref. ITSG, 1999]

The existing NAVRESNET server environment is diverse in terms of both hardware and server operating systems used. Operating systems currently being used include Novell Netware, Unix and Windows NT 4.0. The Naval Reserve plans to migrate to the Windows® 2000 operating system which enables the entire enterprise network to be centrally managed under one domain. Due to the geographic separation of the organizational units and the high cost of training administrators, the capability to centrally manage the network is an important aspect of limiting the total cost of ownership. This transition offers many advantages over Windows NT 4.0, provides a

common operating system environment and meets DON ITSG recommendations on standardization. Advantages include: increased flexibility, scalability, reliability, management capabilities and security.

### **1. Server Operating System**

Significant advances have been made to the server operating system to support the increased functionality and scalability that Windows® 2000 offers. Central to these advances is the Active Directory service that is included with Windows® 2000. The Active Directory allows a single point of administration for all published resources, which include files, peripheral devices, host connections, databases, web access, users, other arbitrary objects, services, etc [Ref. Microsoft, 1997]. An Active Directory is the directory service that is used to logically store and replicate resources in the network. It is a hierarchical directory that forms a tree structure that reflects all organizational resources. This type of directory offers extensive advantages over a flat directory structure in terms of network scalability, reliability and management. Windows NT 4.0 scales quite well up to 100,000 users, but the Active Directory can scale up to over one million users in a single domain, and even larger numbers in a domain tree or forest [Ref. Microsoft, 1997]. The service eliminates the need for master domains and resource domains thereby supporting the management of an organization under a single domain. [Ref. Cone, 1999]

A server configured as a domain controller is required in order to maintain a copy of the Active Directory. Windows® 2000 has improved upon how domain controllers are

implemented which has helped to simplify network management. With Windows NT 4.0, a server can be configured as either a primary domain controller (PDC), backup domain controller (BDC) or a member server. The PDC is a server that manages all aspects of user interaction with the domain. This includes maintaining a directory database of all users in the domain and authorizing domain logons. A BDC is a server that is automatically synchronized periodically with the PDC thereby maintaining a copy of the directory database. A domain can have only one PDC and many BDC that can be located remotely from the PDC. With Windows® 2000, a server can only be configured as a domain controller or a member server; there are no PDCs and BDCs. All domain controllers are peers. Each Domain Controller maintains a copy of the Active Directory and can be used to administer the network. All changes made to the Active Directory are then replicated to all domain controllers. Administrative privileges can be assigned to allow varied levels of access and control to network administrators and users. Windows® 2000 offers a much finer granularity of privileges than Windows NT 4.0 thus making it easier to centrally manage the network. Replication schedules can be modified to compensate for slow WAN links or multiple controllers located at one site thereby balancing replication traffic.

The Naval Reserve Network can be best managed by establishing a single domain with a minimum of two domain controllers at the Network Operations Center (NOC) in New Orleans. In a network of this size, it would make sense to have a minimum of two

domain controllers at the NOC to provide fault tolerance. Additionally, one domain controller BDC will be needed at all reserve centers.

The domain controllers at the centers will share the load of authenticating network logons thereby reducing traffic over the link to the NOC and providing faster response time when logging on to the network. The domain controllers can be configured to also serve as the file and/or print server. As the demands on the network increase, dedicated member server(s) may be required for file and print services, particularly at the larger centers.

This scheme would provide for the centralized management of the network which would reduce the amount of network support training required at the reserve center level. The highly trained system administrators would be able to provide customer support to the centers and remote management of the network. The objective would be to remove as much burden from the end user and local support personnel as possible. This will ultimately reduce the amount of training required and improve the quality of support provided. However, some training of network support personnel would be required at the center level and the assignment of select Windows NT administrative privileges.

Installing and configuring a domain controller for this type of implementation is a relatively complex task. It is important for all domain controllers to be configured in a similar fashion to simplify network administration and troubleshooting. This will also help to reduce the amount of training required of local network support personnel. This could best be managed by having all domain controllers configured at the NOC by the

system administrators who will be centrally managing the network. The domain controllers could then be shipped to all centers with instructions and a number to call for assistance. This approach would reduce the number of problems associated with migrating to a Windows® 2000 operating system and result in a more homogenous network.

## 2. Server Hardware

The ITSG provides extensive guidance on philosophy for configuring and selecting an appropriate server as well as workstations. ITSG "Best Practices" recommends selecting scalable servers that can increase performance by adding components and by supporting standards-based network protocols. Hardware should be scalable, standards based and enable parallel processing. [Ref. DON CIO, ITSG, 1999] Table 4-2 provides a summary of ITSG recommended minimum server hardware guidance for use in selecting an appropriate server.

CPU	Bus	Memory	IO	Peripherals
Pentium II	PCI	RAM≥256MB*	SCSI-2.3	HD≥8GB*
MIPS	VME	Cache≥2MB*		CD-ROM or DVD
Alpha	VXI			RAID 1,3,4,5,6
PowerPC			FC-PH	
PA-RISC			PC Card or CardBus	4mm DAT Tape
Ultra SPARC			IPI	

\*Refer to server OS documentation to determine memory requirements

**Table 4-2.** Server Hardware Guidance [From Ref. DON CIO, ITSG, 1999].

To ensure adequate performance, Windows® 2000 operating system documentation recommends the following minimum requirements:

- 133-MHz Pentium or higher central processing unit (CPU).

- A maximum of four CPUs per computer are supported.
- 256 megabytes (MB) of RAM recommended minimum (128 MB minimum supported; 4 gigabytes (GB) maximum).
- A hard disk partition with enough free space to accommodate the Setup process. The minimum amount of space required will be approximately 1 GB.
- VGA or higher-resolution monitor.

It is important to recognize that these are the minimum server hardware requirements needed to support Windows® 2000 operating system. The actual performance of the server will be limited if the server meets only the minimum requirements and this will significantly impact the overall performance of the network. A more realistic recommended configuration is a 500-MHz Dual Pentium III CPU with a minimum of 512 MB of RAM.

#### **G. UNINTERRUPTIBLE POWER SUPPLY (UPS)**

An UPS is needed to provide protection from voltage variations, noise suppression and to provide temporary AC power in the event of an electrical failure. The length of time varies with the size of the DC batteries, but is typically good for 15-20 minutes. The temporary power is needed to allow time to properly shut down the server so that valuable information will not be lost. The UPS also provides protection against surges in voltage that can damage valuable equipment beyond repair. The UPS provides

significant protection of valuable equipment and data at a minimal cost. Workstations should also be equipped with surge protectors.

## **H. BACKUP SYSTEM**

Every network should have some form of backup as an integral part of an effective disaster recovery plan. It is vital for the network to have an effective backup system and a detailed policy on backing up data. The most common type is magnetic tape backup; because it is reliable, inexpensive, and has enough capacity to back up the entire network on a single tape [Ref. Chellis, 1997] It is the easiest and least expensive means of protecting data [Ref. Hudson, 1999].

Scheduled backups will need to be conducted at the local activity level as well as at the NOC. The NOC will need to backup the data on the domain controller on a more frequent schedule as changes to the data will be occurring regularly and due to the relative importance of the data. The directory database includes critical user account and security data that must be backed up regularly so that the data can be recovered in the event of a hard drive failure.

Backups can be completed directly at each server or remotely over the network to a centrally managed backup system. The disadvantage of backups over a network as large as the Naval Reserves' is the traffic load involved in backing up such a large number of servers and volume of associated data. The impact could be reduced by scheduling the backups to take place at night. The schedule would need to incorporate replicating data

among Domain Controllers. A better approach in this case would be to backup the Domain Controller at the NOC and to backup the local data directly at each individual Domain Controller or server where the local data is stored.

There are several choices of storage media available that vary considerably in terms of cost and performance. Storage media refers to the physical material (e.g. magnetic disk, tape) that data is stored on. Prior to selecting a storage media, backup requirements in terms of data accessibility, storage density, transfer rates, and reliability need to be considered. Tape backup is a widely used means of backing up network data. ITSG best practices recommends implementing storage technology and storage device media that use open access standards, support open device interface standards, and is platform independent [Ref. DON CIO, ITSG, 1999].

#### **I. MODEM/REMOTE ACCESS SERVICE (RAS)**

Remote access to the network is needed to support access to the network by reservists who drill off-site or need to access the network during the month. RAS would also provide access to all local area networks by system administrators who are centrally managing the Naval Reserve Network. A set of modems and Windows NT RAS would support remotely accessing the network for services such as file & print sharing, e-mail, scheduling, database access and network management. The actual number of modems needed would vary by site as some centers have a greater number of reservists that drill off-site. Windows NT supports up to 256 dial-up connections to the network. All

activities will need a minimum of one modem and additional modems can be added as needed.

## **J. LAN ARCHITECTURE SUMMARY**

The information provided in this chapter provides an input that can be used in the development of a more comprehensive network architecture for the Naval Reserve. An architecture is needed to provide direction for information technology managers and to define the Naval Reserve's IT strategy. The strategy should be looked at as an evolving document that needs to be updated regularly and is designed with a view of what the network will look like in the near future (3-5 years).

The Naval Reserve should consider adopting a policy for the central procurement of items such as switches, hubs, NICs, workstations and servers. Some of these components could be shipped directly to the end user rather than via CNRF. This would save on shipping costs and reduce the impact that central procurement would have on CNRF's workload. Servers would be shipped to NAVRISO for configuration prior to distribution. This approach will leverage purchasing power as well as support the DON ITSG recommendations regarding standardization and a homogenous client environment.

The importance of establishing a standard network architecture cannot be over emphasized. Standardization is needed throughout the network to achieve compliance with DON CIO standards guidance, interoperability, compatibility with the fleet, and to establish a network that is effective and highly reliable. The architecture needs to be

defined in sufficient detail to support network design and will serve to provide a uniform approach to network implementation.

THIS PAGE INTENTIONALLY LEFT BLANK

## V. MANAGING PLANNED CHANGE

The previous chapters of this thesis addressed the technical aspects of planning and implementing a network for the Naval Reserve Force. It is equally important to consider the significant impact that the technology will have on individuals within the organization and how to best manage revising how the reserve meets its mission requirements. Extensive changes to business practices will need to be made in order to capitalize on the capabilities of the network.

This chapter focuses on an analysis of the Naval Reserve's implementation of a Wide Area Network (WAN) from the perspective of managing change in a complex organization. The implementation is a multi-year program that necessitates a dramatic change in the organizational culture from one that is based on stand-alone computers into one that is client-server oriented. This is clearly a "trigger event" for the Naval Reserve Force. It presents a complex challenge that must be proactively managed in order for a successful transition to take place. Trigger events are "events that precipitate new behaviors and new thoughts on the part of managers and subordinates as they try to understand what is happening." Organizational restructuring, new senior leadership, closures and relocations of regional activities are changes that have major consequences and are all examples of "trigger events". What makes these events so significant is that they challenge managers to manage into the future as well as in the present. [Ref. Isabella, 1992]

## **A. MANAGING CHANGE**

A plan is needed in order to effectively manage and stimulate any major organizational change within a complex organization. John Kotter has developed an eight stage process for creating and managing change in an organization. The eight steps to transformation are:

- 1) establishing a sense of urgency;
- 2) creating the guiding coalition;
- 3) developing a vision and strategy;
- 4) communicating the change vision;
- 5) empowering a broad base of people to take action;
- 6) generating short-term wins;
- 7) consolidating gains and producing even more change;
- 8) institutionalizing new approaches in the culture [Kotter, 1996].

Applying these stages to the Naval Reserve will help the CIO to gain insight into the issues, identify change agents and develop an implementation strategy. The CIO will serve as the champion for the successful execution of the implementation strategy. Any organizational change of this magnitude requires a champion for the cause who is credible, knowledgeable, charismatic and who holds a position of authority.

### **1. Establishing a Sense of Urgency**

Successfully stimulating change throughout an entire organization requires cooperation, initiative and a willingness to make sacrifices. Many organizations are

unable to create the sense of urgency needed to foster a change of the magnitude that affects an entire organization. The problem is further complicated if the organization is geographically dispersed. Leading practitioners of change management report success rates are well below 50% and may be as low as 20% [Ref. Strelbel, 1998].

A sense of urgency is needed to create the momentum necessary to successfully foster change. "In an organization with 100 employees, at least two dozen must go far beyond the normal call of duty to produce change. In a firm with 100,000 employees, the same might be required of 15,000 or more." [Ref. Kotter, 1996]

The approach to overcoming this problem is to identify possible sources of complacency within the organization and then take positive action to mitigate this complacency. Figure 3 provides a summary of possible reasons for the existence of complacency within an organization as identified by John Kotter.

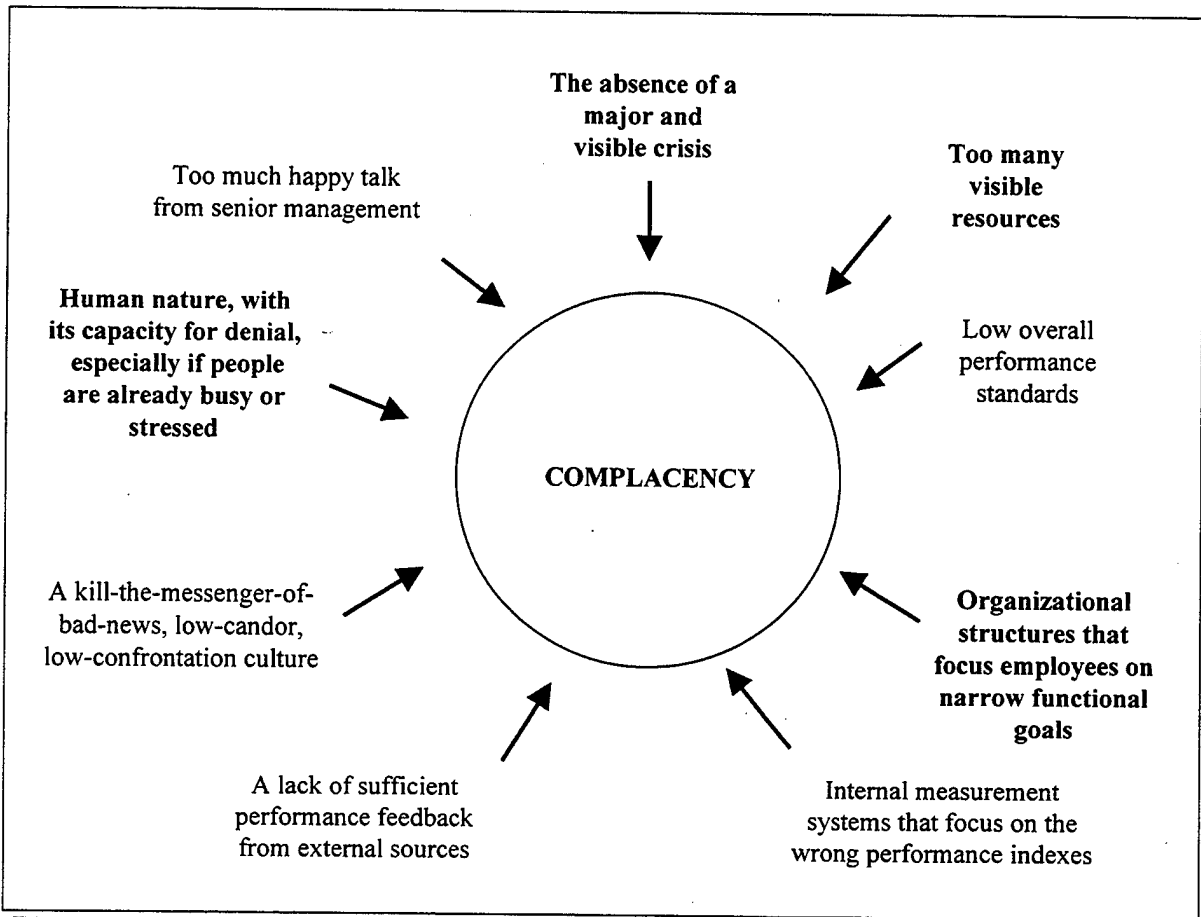

**Figure 5-1.** Sources of Complacency [After Ref. Kotter, 1996].

The sources of complacency with bold lettering are those the author has judged are of most relevance to the Naval Reserve. These sources are manifested in the following examples of complacency:

- Reserve Centers have been successfully meeting mission requirements for many years without the availability of a LAN and a WAN. Many people may not recognize the importance, therefore their sense of urgency is low.
- Staffs at centers are very small, and the ratio of full-time support staff to reservists has decreased in recent years due to downsizing of the military.

Staffs are very busy in keeping up with day to day business and are often resistant to change. They may not see the benefit to be gained from taking time out to learn a new technology for doing business.

- Computer resources are already available to all full-time support staff, so there isn't a clear and visible need for a LAN.
- The structure of the organization focuses the majority of the staff on narrow functional center goals rather than the broad goal of improving mission effectiveness.

Heightening the sense of urgency necessitates the mitigation or removal of sources of complacency within an organization. Good leadership plays an important role in this stage as often innovative or nontraditional actions are needed to create this sense of urgency. This can be difficult due to the size of the organization and resistance to change. There are several actions that the Naval Reserve can take to help to raise the urgency level of establishing the network. These include providing information on the benefits of the network via multiple media, the use of a consultant to bring in an independent view and emphasizing the organizational change through top management.

## **2. Creating the Guiding Coalition**

The coalition for change comprises the Naval Reserve CIO, the surface and air IT headquarters managers and the regional IT representatives who support the 158 centers located throughout the country. There are four essential characteristics for the coalition that is tasked with managing the implementation of the WAN and the associated changes

in business processes. They are positional power, expertise, credibility and leadership. [Ref. Kotter, 1996] The CIO's core staff needs to possess these four characteristics in order to be effective in leading the change process.

The absence of these characteristics will reduce the coalition's effectiveness in communicating the vision to the middle level IT managers and the reserve center commanding officers. These middle managers are in a position where they are able to serve as a significant change agents in the process. Their support is essential to gaining the buy-in needed to reengineer the way that business is being conducted on a day to day basis. Administrative, communication and training procedures need to be revised in order to capitalize on the capabilities of the network. The support of the center commanding officers and regional IT managers is required for the organization to thrive in the new client-server environment. Without the support of middle management, the network may be underutilized, and the change process will lose momentum or stall altogether.

### **3. Developing a Vision and Strategy**

There are numerous sources of resistance that can easily derail the change process. To be successful, buy-in must be gained at all levels and then a cultural change will occur over time. An effective vision is needed to get the buy-in of individuals affected by the change. This is accomplished by clarifying the direction of change and, more importantly, explaining the compelling reasons why the change is needed and it will benefit the organization. To break through the forces that support the status quo, the use of vision is often a more effective tool than micromanagement or an authoritarian approach [Ref.

Kotter, 1996]. Additional motivation for change can be gained by clarifying how the change will benefit the workers in the organization. The intent is to convince individuals that there are better ways of doing business and that they will benefit from revising how they complete their job requirements. Resistance to change can be mitigated if the people who are affected by the change can see some personal benefit. One cannot merely take the approach that because the organization is a military one, that the change can happen by handing down an order to make it happen.

John Kotter describes vision as "a picture of the future with some implicit or explicit commentary on why people should strive to create that future." A well-constructed vision statement is essential to successfully managing change. It helps to clarify the general direction of change, motivates people to take action and helps coordinate the actions of thousands of individuals in a remarkable and efficient way. [Ref. Kotter, 1996]

The objective is to formulate a vision for the future that will provide clear and concise guidance. A vision that will help to align individual actions and that will motivate action that may not necessarily be in people's short-term self-interests. The Naval Reserve Force Information Technology current vision statement reads as follows:

"Force Information Technology will provide seamlessly integrated information and communications systems/capabilities, to support 21st Century mission readiness for the Fleet and other COMNAVRESFOR customers." [Ref. CNRF, Vision, 1999]

The mission statement is identical and posted on a separate web page. The mission and vision needs to be updated to better reflect the direction of the transformation that the Naval Reserve is undertaking. It can be further strengthened by including a set of goals that more clearly define the steps involved in the change and a timeline for implementation. The timeline is important not only for providing milestones for the various stages of implementation but also as means to inform people in the organization that the network is not going to be built overnight. People who support the change will have a tendency to get excited initially and then get discouraged when the change does not come about as fast as they anticipated. A timeline needs to be provided and updated as changes occur. Also, should be updated to offer explanations for any significant delays; without this, leadership's credibility will be weakened.

The value of the vision can be strengthened if a consensus for commitment to the vision can be obtained. One approach to accomplish this is to involve the coalition and regional IT managers in the process of developing the vision. An IT summit conference would present a good vehicle for gaining consensus. The end result is a vision for the future that is desirable, feasible, focused, flexible, and is conveyable in five minutes or less [Ref. Kotter, 1996].

#### **4. Communicating the Change Vision**

Communicating the vision to an organization as large as the Naval Reserve Force can be a daunting task, but doing so helps to gain acceptance and motivate change. The amount of time and effort required to communicate the vision can be tremendous. By

following seven principles in the effective communication of vision, the magnitude of the task can be overcome. The principles are:

- simplicity;
- metaphor, analogy, and example;
- multiple forums;
- repetition;
- leadership by example;
- explanation of seeming inconsistencies;
- give-and-take [Ref. Kotter, 1996].

By putting Kotter's principles into action, a variety of approaches can be developed to tackle the problem.

- The vision statement needs to be clearly posted on CNRF's web site. Currently the vision is posted on a link off the homepage. By incorporating the vision statement as a focal point on the homepage, the visibility and impact of the statement will be increased.
- Incorporate diagrams on the network architecture that reflect the future vision of the WAN. Diagrams need to be included on the current state of the network and the 3-5 year vision for the future. The diagrams will help to provide guidance to IT managers and communicate to CNRF activities the planned direction for updates to the network.

- Multiple and repetitive methods need to be used to convey the vision for the future. Examples include field commanders conferences, IT conferences, FY goals and objectives, newsletters, direct letters from the CIO and Force Master Chief, electronic media, etc.
- The central idea is to disseminate the message across all levels of the organization a multitude of times and via several methods.

#### **5. Empowering Employees for Broad-Based Action**

There many barriers to empowering people in an organization, particularly in a bureaucratic environment such as the Naval Reserve. This stage of managing change is geared towards removing barriers to change. The vision has been communicated and the individuals in the organization have bought into the change. At this point people are motivated to change. The goal is to remove barriers to empowerment, thereby minimizing frustrations that will stall the transformation. Figure 4 identifies the four most significant barriers to change: structures, skills, systems and supervision [Ref. Kotter, 1996].

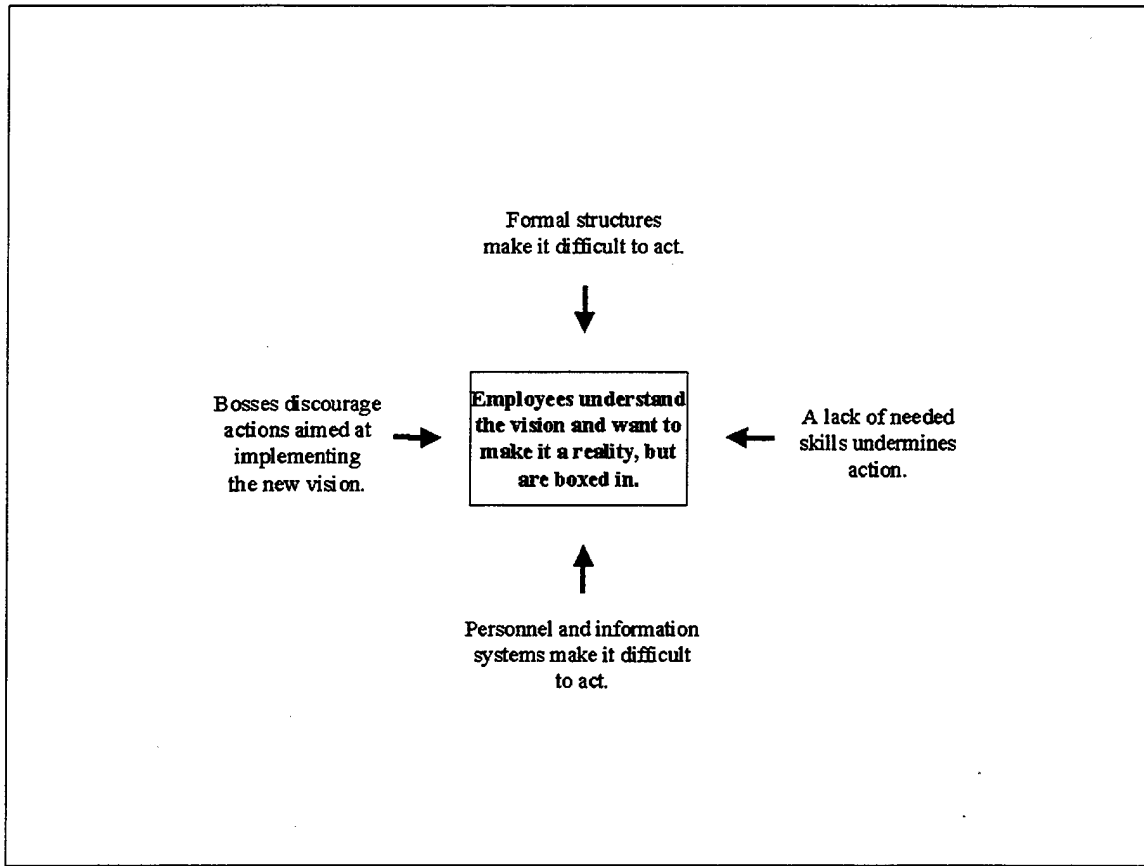

**Figure 5-2.** Barriers to Empowerment [Ref. Kotter, 1996].

In order for change in processes to occur, action needs to be taken by the various stakeholders in the organization. If they attempt to take action and bureaucratic procedures block them from doing so, they will quickly become discouraged, and the change effort will fail. Innovation needs to be encouraged and those who initiate new procedures need to be rewarded to motivate further change initiatives. Procedures developed that are clearly better than the old way of doing business need to be identified and shared throughout the organization. The environment needs to be open to revised methods; don't let middle managers block change by fostering an environment that

accepts answers like "but it's always been done this way before" or "but the instruction doesn't support this revision to procedures". Often there is a lag in time before instructions and directives are able to catch up with current technologies and changes in procedures. If a revision to procedures makes sense given the new environment, then the revision should be made. When it makes sense, make the changes, get the support of the chain of command and follow it up with updates to instructions and directives.

## **6. Planning for and Creating Short-Term Wins**

Short-term wins are needed to reinforce the change effort by providing visible evidence that the organizational efforts are paying off. They provide the catalyst for motivating and maintaining the support that is needed for any multi-year change effort to succeed. The positive effect can be strengthened by creating a series of wins in incremental time periods (e.g. one every six months).

Three characteristics of an effective short-term win are:

- it is visible to large numbers of people in the organization;
- it is unambiguous;
- it is clearly related to the organizational change [Ref. Kotter, 1996].

The establishment of the network involves many tasks, which are often interrelated and may have to be completed in a sequential process. The frame relay network infrastructure, supporting operating system and applications software will be deployed in phases to all Naval Reserve Force activities. Development of the network design and the sequence of installation is currently ongoing. The concept of creating

short-term wins can be applied to the planning and deployment of the network. Effective planning should include a review of the network requirements analysis so that consideration can be given to focusing on the requirements that provide the most benefit and are visible to the end user as early on as feasible. Effective e-mail and connectivity to the Internet are examples of requirements that provide significant benefit soon after the infrastructure and needed software are deployed to the field. The central point is to address the items identified in the requirement analysis that provide the most benefit as soon as practical in the project, subject to the constraints of the sequential nature of the steps involved in establishing the network. This helps to build the necessary motivation and momentum for change.

#### **7. Consolidating Improvements and Producing Still More Change**

The establishment of the Naval Reserve Network is still in the early stages of what is a multiyear program. The project's visibility and momentum will build, and major milestones will be met in the coming year. This can be a tenuous stage of the change process and it needs to be addressed in order to avoid losing valuable momentum. As Kotter says "Whenever you let up before the job is done, critical momentum can be lost and regression may follow. Until changed practices attain a new equilibrium and have been driven into the culture, they can be very fragile." [Kotter, 1996]

A review of past major change projects indicate that momentum can be lost and sometimes never regained when leaders emphasize the success of the project before its completion, thereby suggesting to the personnel that the project is complete. The praise

needs to be presented in terms of objectives completed, the long-term nature of the project and the tasks that still lie ahead.

The coalition needs to keep in mind that change takes a long time. With the rate that IT is currently advancing, an argument can easily be made that the change process is an ongoing evolution. Certain points in a project are more critical than others, and organizations need to proceed with caution in order to avoid stalling the change process. Resistance to change, transfer of key personnel of the coalition and exhaustion on the part of leaders are examples of forces that can inhibit the transformation. The power of culture and tradition makes it easy for people to fall back into the old way of doing business. The problem associated with the transfer of key personnel is particularly relevant to the military given that personnel are transferred regularly. Careful consideration needs to be given as to who will be selected to relieve the CIO and members of the coalition when they transfer. An alignment of vision is needed to ensure that the project will continue to thrive.

The point is to maintain the momentum through long-term planning and communication and by generating more wins. The emphasis needs to be placed on increased innovation, rewards for those that demonstrate a willingness to change and revised business practices will make full use of the network. The leadership needs to show ongoing support for the process or it may stall or be lost completely.

## **8. Anchoring Changes in the New Culture**

The organizational culture of the Naval Reserve is powerful and not something that can be easily changed. This is true in many large organizations; it is even a stronger force in a military organization such as the Naval Reserve. This can be attributed to a culture that is based on a strong sense of tradition and heritage, the nature of the working environment and a set of common experiences of personnel under often-stressful situations.

"Culture refers to norms of behavior and shared values among a group of people. Norms of behavior are common or pervasive ways of acting that are found in a group and that persist because group members tend to behave in ways that teach these practices to new members, rewarding those who fit in and sanctioning those who do not. Shared values are important concerns and goals shared by most people in a group that tend to shape group behavior and that often persist over time even when group membership changes." [Kotter, 1996]

The Naval Reserve is seeking is cultural change from business practices based on a stand-alone computer environment to those based on a network environment. This will involve many changes to the norms and values of the culture. As the network is implemented, business practices will be modified in order to improve the efficiency and effectiveness of the reserve. However, anchoring these changes in behavior and in shared goals will not happen until the final step of the transformation process. The forces of culture are powerful; therefore, it is important to realize that institutionalizing the changes into the culture of the Naval Reserve will not be an easy task. Key elements to anchoring change in a culture include: realizing that cultural change comes last, not first; it depends on results; requires lots of instruction and support; often involves counseling or replacing

personnel; and requires recognition and advancement for those who are innovative and embrace change. Therefore, it is critical for the revised business methods to clearly be a significant improvement over previous methods. Also, performance evaluations must reflect favorably on those who adapt well to the new system and who provide positive contributions to the change effort. These efforts will reinforce the cultural change across all levels of the organization.

## **B. STRATEGY FOR SUCCESSFULLY MANAGING CHANGE**

Having completed an organizational analysis and the application of John Kotter's eight stage process for creating and managing change, it is evident that steps can be taken to increase the likelihood that a successful transition will occur and reduce the time required for the transition. Several recommendations follow:

### **1. Revitalize the CNRF IT Web Site**

The web site needs to be the centerpiece for promoting the vision for the future and the strategy for implementing the Naval Reserve Network. The site needs to be expanded and updated regularly to include details on the network implementation. The content needs to be well organized, current and accurate to build credibility and usage of the site. Expansion should include a bio on the CIO and his guidance for the future. Also, presentations and minutes from conferences that are downloadable for review and dissemination. Revitalization of the web site needs to include a review of SECNAVINST 5720.47, which provides the Navy's policy for authorized content on web sites that are

publicly accessible. Also, a review of ITSG needs to be completed, which includes guidance for developing a user-friendly web site as well as a details on security vulnerabilities.

## **2. Revise the CNRF IT Mission and Vision**

The vision needs to clearly articulate the direction for the future and include goals for achieving the vision. This will help to focus the efforts of the multitude of individuals that are affected by the establishment of an effective Naval Reserve Wide Area Network.

## **3. Develop a Information Management (IM) Strategic Plan**

The plan should be developed by the CIO's IT coalition and geared towards providing a roadmap for pursuing future improvements to the Naval Reserve IT infrastructure. This would serve to provide clear direction from the CIO of the Naval Reserve on information management vision, top goals and objectives, and strategies for accomplishing the goals. The plan needs to be widely published and could be tailored after the DOD CIO's strategic plan.

## **4. Biannual Information Technology Summit**

Significant gains have been made as a result of the recent CNRF IT summit. It helped to establish better communications and IT coalition for the future. Follow on conferences need to be held regularly to continue to build the team for the future. Feedback on action taken based on input received at the conference is an important aspect of building the team and fostering credibility. Future conferences could be improved by

inviting guest speakers who are experts in the IT field to address current technology being implemented by the Naval Reserve.

#### **5. Information Technology Newsletter**

Action needs to be taken to develop and publish a quarterly IT newsletter. The newsletter would highlight progress on implementing the network, feature success stories on revised business practices, provide information on relevant IT technology, address end user questions, announce training opportunities, etc. The target audience would be the end users of the network, and it could be disseminated electronically as well as by hard copy.

#### **6. Fiscal Year IT Goals and Objectives**

Expand CNRF IT goals message to include an end of the year summary on progress made on completing the previous year's goals. This would serve as an annual report of accomplishments and would be widely distributed throughout the Naval Reserve.

#### **7. Training**

Extensive training needs to be conducted for all users and network support personnel. The training should be conducted to coincide with the installation phases of the network. Application of the concepts presented during training needs to follow shortly after the training provided. A minimum skill set list needs to be identified for all users and support personnel. The training will help to reinforce leadership's commitment to

technology and cultural change as well as providing the users an understanding of the resources that are available.

#### **8. Recognition and Awards**

The Navy recognizes the importance of rewarding excellent performance. This also can play an important role in a major change effort. Recognition through awards and positive performance evaluation help to motivate personnel and to create a positive environment that will stimulate innovation and revised business practices. By rewarding actions that support the change, leadership can reinforce an individual's commitment as well as to inspire others in the organization.

#### **9. Centralized Helpdesk**

Restructure NAVRISO to provide customer support to the network end users and support personnel. NAVRISO currently provides customer support serving as the Network Operations Center (NOC); however change needs to be made to address the modifications to the Naval Reserve Network. The NOC needs to update its network management software and system for tracking network problems. This will result in improved customer service and helpdesk efficiency.

#### **10. Network Architecture**

Develop and define a network architecture that includes a standardized reserve center Local Area Network architecture. This is needed to provide a vision for the future of the network and direction to reserve commands. The architecture could be made

available on the web in a drilldown format that would allow the user to click on the diagram to get more information or look farther into the architecture of the network.

### **C. MANAGING PLANNED CHANGE SUMMARY**

There are many challenges to overcome when making changes to a large and complex organization such as the Naval Reserve. This is particularly true when undertaking a project as lengthy and complex as implementing a Wide Area Network to support a multitude of requirements for an organization of over 80,000 personnel who are geographically dispersed throughout the United States. Many change efforts of this magnitude fail to succeed in making the needed changes to business practices, organizational structure and culture. It is important to realize that in order for the project to be a success, more is needed than a detailed network design and implementation plan. To assume that the technology will be readily accepted and incorporated into business practices without considering how to best manage organizational change would be a costly mistake. The plan must incorporate a strategy for change that is based on management concepts that can be derived from John Kotter's eight stage process for creating and managing change in an organization. Without a plan to manage change, the new technology will be underutilized, the efforts of many people in the organization will be mitigated, the amount of time required for the change will increase, and the change effort could potentially fail. By incorporating strategies that focus the organization on the future vision, building momentum and removing barriers to empowerment, the Naval

Reserve can move towards a more effective force that is ready to meet the mission requirements of the future.

THIS PAGE INTENTIONALLY LEFT BLANK

## VI. SUMMARY AND CONCLUSIONS

### A. SUMMARY

This thesis focuses on an analysis of the technology and the steps involved in planning, designing and implementing the Naval Reserve Network (NAVRESNET). The Naval Reserve Force is undergoing a complex and long-term program that will significantly upgrade the network and ultimately result in changes to the methods used to meet mission requirements. There are many challenges associated with a project of this magnitude that can impact the overall effectiveness and success of the network. This analysis looked at the aspects of the implementation with the objective of identifying challenges and recommendations for the successful integration of the network into the Naval Reserve's organization.

The thesis provides background information, discusses the mission of the Naval Reserve and Infrastructure Plan 2000 as well as its relationship to the Naval Reserve Network. Additionally, it discusses the benefits that the network will have for the Naval Reserve and the Active Navy.

It covers the fundamentals of networking that are needed in order to go forward with designing and implementing a network that will be suited to the unique characteristics of an individual reserve center. A framework for designing a local area network was identified and described in detail. This framework, when combined with a

defined standardized architecture, will be useful to reserve centers as they design and implement a LAN.

The thesis includes a review of leading network design tools such as Visio Professional. The use of design tools supports the design process and offers substantial benefits by providing tools for documenting the network and for developing a network architecture.

Recommendations for a standard architecture were developed that can be used by CNRF in the development of a more comprehensive network architecture for the Naval Reserve. An architecture is needed to provide direction for IT managers and to define the Naval Reserve's IT strategy. The strategy should be looked at as an evolving document that needs to be updated regularly and is designed with a view of what the network will look like in the near future (3-5 years). The objective is to provide a roadmap for use in network planning.

In addition to a standard architecture, the Naval Reserve will need to make changes to business practices in order to gain the most benefit possible from the updated network. It is important to realize that, in order for the project to be a success, more is needed than a detailed network design and implementation plan. To assume that the technology will be readily accepted and incorporated into business practices without considering how to best manage organizational change would be a costly mistake. This thesis includes a review of the issues surrounding the impact that the network will have

on individuals in the organization and the development of a strategy for managing change.

## **B. KEY RECOMMENDATIONS**

The Naval Reserve Network has the potential to provide significant benefit to both the fleet and the reserve community. For the project to be successful, a great deal of effort will be required by senior leaders in the Naval Reserve as well as by individuals throughout the organization. The focus of the effort cannot be limited to the technological aspects alone; it must also include efforts to gain acceptance of the technology, train administrators, support personnel and end users, and to revise business practices to take advantage of the network's functionality. The following section identifies key recommendations that are essential to the successful implementation of the network and to reducing the time required to develop an organizational structure that will thrive in a network environment.

### **1. Standardized Network Architecture**

The Naval Reserve Chief Information Officer needs to develop and publish a detailed Wide Area Network architecture that includes a standardized Local Area Network architecture. The architecture must be developed based on DON CIO standardization guidance. This approach will support the development of an integrated network that is scalable and based on current technology and industry best practices. Standardization is a critical aspect to implementing an integrated network that is

interoperable with other Department of Defense networks. The network architecture is needed to provide a vision for the future of the network and direction to CNRF reserve commands.

## **2. Centralized Management**

The network needs to be designed with centralized management as a primary consideration. The ability to centrally manage the network is needed due to the cost associated with training network administrators and the regular transfer of personnel within the Navy. A core team of network professionals is needed at the Network Operations Center (NOC) to provide for the stability and support of the network. The goal would be to reduce the technical level of training required at the center level and to have the ability to centrally manage the network at a reduced overall cost. The professionals at the NOC would need to be well trained and compensated. Due to the high demand for qualified IT experts, it will be imperative that the Navy have the funding in place to compensate on a par with civilian corporations.

## **3. Windows® 2000 Operating System**

The network needs to be based on a design that uses Windows® 2000 operating system and configured to support centralized network administration from the NOC. This scheme supports the central management of the network and minimizes the burden on reserve center network support personnel. A domain controller should be established at the reserve center level to share the load of authenticating network logons.

Administrative privileges can be assigned to allow varied levels of access and control to network administrators and users.

#### **4. Standardized Server Configuration**

All domain controllers should be configured at the NOC by the system administrators who will be centrally managing the network. Installing and configuring a domain controller for this type of implementation is a relatively complex task. It is important for all domain controllers to be configured in a similar fashion to simplify network administration and troubleshooting. This will also help to reduce the amount of training required of local network support personnel. After configuration, the domain controllers would be shipped with instructions and a number to call for assistance. This approach would help to reduce the number of problems associated with migrating to a Windows® 2000 operating system and result in a more homogenous network.

#### **5. Centralized Procurement**

The Naval Reserve should consider centrally purchasing components such as switches, hubs, NICs, workstations and servers. This will leverage purchasing power and provide for a more uniform network environment. A uniform environment is needed to support network integration, centralized network administration and to help reduce the total cost of ownership.

#### **6. Training Plan**

Increased funding and a plan for the training of network administrators, support personnel and end users is needed. The amount of training required will vary

considerably depending on individual roles in the organization. A required skill set needs to be identified which would reflect the minimum computer skills needed to fulfill the various job assignments in the Naval Reserve. As a supplement to training, funding should be made available to purchase publications on network essentials and the Windows NT operating system. As the Naval Reserve's reliance on technology continues to grow, the available funding for educating the personnel who support and use the network also needs to grow.

#### **7. Document the Network**

A standard network design tool is needed for use throughout the Naval Reserve. A network design tool such as Visio Professional will provide substantial benefit by helping to make the design process an easier one and by providing a tool for documenting the network. Documenting the network is a particularly important aspect of network management given the rate that networks tend to grow over time and the turnover rate of network support personnel. The physical layout of the network needs to be documented to aid in troubleshooting and planning for the future growth of the network.

#### **8. Strategy for Managing Change**

The implementation of the NAVRESNET presents a significant challenge for management in terms of how to best manage the restructuring and the impact that the technology will have on individuals in the organization. Chapter V covers these issues in detail as well as outlining a specific strategy for successfully managing the transition. It is

essential that the CIO develops a transition strategy that considers the issues and the specific recommendations provided in Chapter V.

### **C. TOPICS FOR FUTURE RESEARCH**

This study has focused on aspects of the Naval Reserve Network related to planning, implementation and design. As the network becomes established, there will be other opportunities for further study and resulting recommendations for improving the network.

The issues surrounding the training of network administrators, support personnel and end users is an area of future study that would benefit the Naval Reserve. Training can be very costly and the benefit mitigated by the regular transfer of personnel within the reserve and due to the potential for individuals to leave the Navy after receiving extensive training on networks. Study in this area should include identifying a minimum skill set, exploring options for providing training and identifying incentives to retain qualified network administrators.

Business process reengineering is an important aspect of ensuring that the network will not be underutilized and is an area of future study that would benefit the Naval Reserve. The network is expected to have the capability of meeting numerous requirements that were identified as part of the requirements analysis phase of designing a network. The objective is to increase overall productivity and to better meet mission requirements through the use of current information technology. To meet this objective,

key processes need to be identified and changes made to those processes. Study in this area should include assessing the level of utilization of the network, an assessment of the end users' perceptions of the network's ability to meet their expectations and an analysis of the success of the organizational change effort.

An analysis of the CIO's web site would provide future benefit to the Naval Reserve. The study would include a detailed review of the content, design and usage of the current site as well as a requirements analysis and proposal for improving the web site design. Changes to the site are needed to increase functionality, usage and overall effectiveness as a key tool for communicating the Naval Reserve Force the CIO's strategy and vision for the future. The objective of the study would be to provide design recommendations that will result in an effective site that will enhance the organization's image and clearly communicate the organization's vision and goals.

#### **D. CONCLUSIONS**

In the coming years, the Naval Reserve Network will continue to advance in terms of the technology employed, its scope, its application and its role as an integral part of supporting the mission of the Naval Reserve. The network is expected to support the Naval Reserve in making critical changes in business practices, and to result in increased readiness and capabilities to support the fleet. This thesis analyzed the initial phase of the network implementation, identifies the challenges associated with the implementation

and points out strategies for the Naval Reserve Force to use in overcoming these obstacles.

In overcoming the challenges associated with the implementation of the network, the relative importance of establishing a standard network architecture cannot be over emphasized. Standardization is needed throughout the network to achieve compliance with DON CIO guidance, interoperability, compatibility with the fleet, and to establish a network that is effective and highly reliable. The architecture needs to be defined in sufficient detail to support network design and will serve to provide a uniform approach to network development.

THIS PAGE INTENTIONALLY LEFT BLANK

## APPENDIX A. SOURCES OF GUIDANCE ON NETWORKS

The following is a list of sources of additional amplifying information to implementing a network in a DOD environment.

### **Cisco Systems, Inc.**

<http://www.cisco.com/>

Provides access to technical documents and support for Cisco products, including the Cisco 3940 Router and a wide variety of hubs. Additionally, background information on the fundamentals of network design, network essentials and examples of how to apply Cisco products in a wide range of networking scenarios is available.

### **Department of the Navy IM/IT Homepage**

<http://www.doncio.navy.mil/reference/don/index.html>

Provides a access to IT related documents from the Department of the Navy, including the ITSG and ITIA. The ITIA describes the manner in which information will be exchanged over networks, defines components, selects protocols, describes network services, suggests best practices, performance measures, and how security mechanisms will be deployed. The ITSG amplifies the ITIA to describe how the components of the architecture must connect and interoperate.

### **Department of the Defense CIO Homepage**

<http://www.c3i.osd.mil/>

Provides a access to IT related documents from the Department of the Defense, including the DOD Information Management (IM) Strategic Plan. The plan provides overall guidance for managing information resources and establishes a vision for the future. The design of the plan and the site is particularly well suited for promoting a vision and goals for the future. This site provides a good framework for the Naval Reserve to use in revising their homepage. It also includes links to other DOD information technology web sites.

### **Institute of Electrical and Electronics Engineers, Inc**

<http://www.ieee.org/>

The IEEE is a non-profit technical professional association that is a leading authority in computer engineering and telecommunications and other technical areas. The IEEE publishes literature and establishes consensus-based standards on information technology that are used throughout the industry. Copies of individual IEEE standards are available via the web at a cost.

### **Microsoft Windows 2000 Homepage**

<http://www.microsoft.com/WINDOWS2000/default.asp>

The Windows 2000 Homepage provides extensive information on the Microsoft's new operating system that is useful for keeping current with updates and deployment planning. It includes access to white papers, training, forums, product guides, links to other sources and other valuable information. It provides all the basics needed to learn about Windows® 2000 as well detailed and in-depth technical information.

### **Navy Information Security Website**

<http://infosec.nosc.mil/>

This site provides access to antivirus tools, technical assistance with information security related problems and suspected attacks to DOD computer systems. The site also provides access to computer security related training materials, products and documents containing guidance on computer security. One example of a particularly good reference is the DON Secure Windows NT Installation Guide which provides implementation guidance for the secure installation and configuration of the Windows NT 4.0 Server and Workstation Operating Systems.

### **NETG Web University**

<http://www.usn.netg.com/> or

<http://www-cbt.cnet.navy.mil/>

This site provides the availability to a wide range of information technology training that are offered under a DOD wide contract. Over 300 downloadable courses are available at no cost to Navy and Marine personnel. NETG courses range in coverage from end user to high level technical training. Initial access to the website is gained by using "usn" for both the username and password. After registering, a unique identification number will be assigned.

### **Webopedia**

<http://www.pcwebopedia.com/>

The Webopedia is an excellent online dictionary that covers computer and Internet technology. Great site for quick access to network technology information.

## APPENDIX B. NETWORK DESIGN TOOLS

Network design tools are a type of DSS that can help in the planning of networks. The use of design tools can often improve network efficiency, reduce costs, and improve performance. Additionally, they help to predict future network performance, and to ensure that the network has sufficient capacity to handle new applications. This is accomplished by using design tools to develop a static or dynamic model of a network that can be changed quickly and inexpensively in order to analyze different design alternatives and compare the projected performance.

### A. NETWORK DESIGN TOOLS

According to David Passmore's article called "Modeling The Network", there are several different categories of network design tools that offer a wide range of functions that support and improve network design and management decisions [Ref. Passmore, 1998]. Summaries of the categories in increasing order of functionality are as follows:

**Drawing Tools:** Used for planning the topology and to create static network diagrams, drawing tools save time and improve the overall quality of the design. Drawing tools typically lack modeling or database capabilities, however, are excellent tools for documenting the current state of a network or a template of a planned network. Multiple individual alternatives can be quickly created and compared in order to improve the

design process. Visio, a business diagramming and technical drawing software package is an example of a widely used and respected drawing tool.

**Physical Network Configurators:** These products are considerably more powerful than drawing tools. The user creates a network drawing using a knowledge base of device libraries from multiple vendors. These libraries are updated regularly and include detailed information about each network component. The information is used to automatically validate each component's configuration and placement within the network topology. The location and interrelationship of components in an existing network can be automatically discovered using SNMP polling. Examples in this category include the Advanced Professional Design product from NetSuite and the Caliper product from Network Tools.

**Logical Topology Analysis:** These products can automatically analyze the network in order to extract router and network configuration information. With this information, the tools gain detailed knowledge of each network element's routing and filtering behavior, as well as detailed knowledge of the performance and capacity of the various routers and switches. The resulting information is valuable to analyze interactions between traffic flows, topologies, routing parameters, and router configurations. The information can be used to establish baseline performance characteristics of the network. The information provided covers both static and dynamic delay. Static delay is the delay associated with signal propagation and the components in the network, and dynamic

delay includes the transit delay with a load. Cisco's Netsys products are an example of tools in this specialized category.

**Model-Based Multi-Phase Tools:** Products in this category provide all of the functionality of the physical network configurators. Additionally, they provide network performance analysis (static only), auto-discovery using polling, cost estimates of WAN services and least-cost design strategy recommendations.

**Simulators:** In order to model the performance of individual applications, simulators are used to simulate discrete events for each transaction. These tools are typically used to model the performance of individual applications running on specific host computers rather than simulating an entire network. Products in this category are typically complex, and require a large amount of time and technical expertise. Generally, this type of tool is not used to model automated administrative offices with a wide range of diverse applications and unpredictable traffic flows. Examples include COMNET and Extend.

## **B. NETWORK DESIGN TOOLS FOR THE NAVAL RESERVE**

Significant benefit can be gained by the Naval Reserve through the utilization of network design tools, particularly in view of the current infrastructure reorganization. Immediate benefit would be in the form of improved network design, improved performance, reduced cost and architecture standardization. As previously stated, there are a wide and growing number of network design tools available. A close look at the

Naval Reserve requirements (needs assessment) is needed in order to determine which of the available Network Design Tools will provide the most dividends.

The Naval Reserve is not currently using a network design tool and limited guidance on using standard components is being provided to reserve centers on the implementation of LANs. This presents a significant risk in terms of system cost, standardization of components and integration. The problem is even more evident given the varying levels of expertise at reserve centers, the limited involvement of readiness commands due to time constraints, proximity and the number of centers. A template showing a standard network architecture, system components, desired functionality and logical relationship among components would significantly improve the overall performance and standardization of the IT infrastructure.

Consideration also needs to be given to the management of the LAN after it has been established. An important aspect of the management is the documentation of LAN topology, components and configuration. Documentation is particularly important given that staff at a reserve center typically transfer every two to three years and often without the benefit of a contact relief (face-to-face). Documentation of the network is important for tracing problems with the system, evaluation of the system performance and future planning. A network design tool with drawing and database capabilities can handle the task of documentation and will serve as a vital tool to management.

The majority of the reserve centers will be implementing a LAN comprised of one server, 20 to 40 desktop computers, printers, 2 to 4 hubs and category 5 copper cable. The

LAN will primarily be used for general office automation, file sharing, interoffice communication, e-mail, and Internet access. Future expansion plans for the LAN include establishing a WAN comprised of all activities under Commander Naval Reserve Force authority. Additionally, making the various stand alone database management systems that support the Naval Reserve available at all desktop computers.

In reviewing the current requirements, it seems that the most practical network design tools for the Naval Reserve are those that would assist in creating a standard design template, offer network documentation and physical equipment/software configuration validation, rather than those that predict network performance.

### **C. SELECTION OF A NETWORK MODELING TOOL**

Three products that fall into this category and are currently being widely used in the network design industry are Visio Professional 5.0, NetSuite Advanced Professional Design 4.0 and Aperture for Networks. A detailed comparison needs to be completed in order to select which product would provide the most benefit to the Naval Reserve. All of the products provide a user-friendly graphical interface and drag-n-drop network components. Table B-1 provides a summary comparison of the modeling tools' primary attributes.

Modeling Product	System Requirements	Cost	Major Features	Comments
Visio Professional 5.0 POC: Doug Tebo 1-888-644-1800 Ext.505	Win 95 (8MB RAM) NT Workstation (12MB RAM) 386 PC or higher (25MHZ or faster) VGA, SVGA, or XGA, Graphics Card	Base \$399 Network Equipment Model (VNE) \$499 Enterprise Discovery Module \$395 Library Subscription \$199/yr	Diagramming Package Powerful Set of Wizards Database Capabilities 14000 network shapes Ability to save drawings in .html (post on Internet)	Designed to help visualize the physical layout of a network. Stencils are provided for network drawing as well as many other applications.
NetSuite APD 4.0 POC: Scott Leaver 1-978-318-5072	Win 95, Win NT Workstation 4.0, Pentium 100MHZ or higher, 32MB RAM or higher	Base \$2,500 Audit Module \$5000 Tool-Kit \$1000 Lib Subscription plus Maintenance \$500/yr	Documentation Diagramming Design Validation Discovery Bill of Materials HTML Web Publishing	Automates and adds intelligence to the design process. Other modules are available that offer added functionality.
Aperture for Networks 1-203-357-0800	Win 95, Win NT Workstation 4.0, Pentium 100MHZ or higher, 32MB RAM or higher	Base \$4,855-includes 3 yr. Maintenance and library updates	Diagramming Documentation Precision Drawing Tool Real time Web publishing capability Powerful Linking Tools	Diagrams are integrated with a relational database. Diagram represents both the logical & physical view.

**Table B-1. Network Modeling Tools Comparison**

Netsuke's product provides the most functionality and expandability of the three and is also the most costly. The most notable capability of NetSuite is its ability to validate the logical design of the network. This reduces the chance of an inexperienced network designer making costly design errors, saves time and improves the overall quality of the design. This could prove particularly beneficial to the Naval Reserve as most centers have minimal experience with network design and need an expert system to help with design validation. The validated design can then be exported to a third-party simulation tool to analyze the expected performance of the design. A list of materials and components are automatically created by NetSuite and includes the manufacture name, product type, part number and a cost estimate. NetSuite also comes with an easy to use

tutorial that provides a detailed look at NetSuite capabilities and sample designs. The tutorial can be completed in about two hours and is an excellent medium for learning.

Visio is widely used by network design professionals because of its affordability and ease-of-use in creating detailed network design diagrams. Features such as: over 14,000 network shapes, several wizards, templates and data links to shapes make Visio a powerful and easy to use product. Data links is an important feature that supports documenting detailed information regarding components in the network. This embedded information can be exported to a database (e.g. Microsoft Access or Excel) to provide detailed documentation of the network. This feature can be enhanced by purchasing Visio Network Equipment (VNE) which is an add-on module that includes 14,000 shapes with embedded detailed manufacture specifications. Additional fields can be added to document user-specified data. Figures B-1 through B-3 provide examples of diagrams created using Visio. The design tool is also popular because it includes comprehensive business diagramming capabilities, such as, flow charts, basic process reengineering, process management, software and database development, and web site design. Recently, Visio released a new product "Visio Enterprise" which expands the capabilities to include auto discovery. The drawback is its inability to validate connections or to do simulations. Visio can be integrated with other third-party vendors who have additional design and performance tools.

Aperture is primarily used to diagram and document networks. Aperture includes database capabilities that are similar to Visio, standardized reports, and the ability to link

drawings together and add intelligent regions to the drawings. When objects are placed within an intelligent region they assume the record data of the region. A distinct feature of Aperture is the capability to publish network information in real time to a web site. This is accomplished by saving the network file in two locations whenever a change is made. Eventually this capability will be expanded to be fully functional as GroupWare for teams of network designers who will work closely to design and document complex network systems. It does not include design validation and auto discovery capabilities.

#### **D. BENEFITS OF NETWORK MODELING TO THE NAVAL RESERVE**

The use of a Network Design Tool would provide several significant benefits to the Naval Reserve in the successful restructuring of its organization and the establishment of a quality IT infrastructure. A summary of the benefits of using Network Design Tools includes the following:

- Reduce the time it would take to develop comprehensive Network Designs.
- Improve the communication of the guidelines on establishing LANs.
- Enhance the overall performance and quality of the network.
- Help to standardize the design of LANs.
- Provide an easy method to thoroughly document the details of the components of the network.
- Serve as a valuable tool for network administration by saving time, supporting trouble shooting, monitoring performance, and planning for future expansion.

- Reduce lifecycle costs by providing detailed documentation of the network layout. This will prove very valuable for troubleshooting, planning for future expansion and reducing the time it takes to train new network administrators when personnel transfers occur.
- Provide predictions on performance that can be expected from a design choice and a method of monitoring actual performance and system utilization. This would provide valuable insight as to when additional capacity is needed or indications that there may be a problem with the network.

#### **E. RECOMMENDATIONS**

Prior to the Naval Reserve making a final decision on which product to select, the author recommends that the Naval Reserve contact both companies to get a competitive bid on the cost as price varies depending on number of copies ordered, government discount and options selected. Both Visio and NetSuite offer evaluation copies of their products and have extensive information available on their company web site. Additionally, they periodically offer one-day seminars at various locations throughout the country. These seminars are typically at no cost and are very informative. A more informed selection could be made by having a few of the end-users test-drive both products and attend a product seminar. While doing research for this paper the author had the opportunity to use NetSuite and Visio network design tools. Both products were

found to be user friendly, relatively easy to learn the main features, and beneficial in developing detailed network design diagrams.

It is clear that the use of network design tools would provide substantial benefit to the Naval Reserve in the establishment of an effective IT infrastructure and that IT will prove to be a vital element of the successful implementation of Infrastructure Plan 2000. Visio Professional 5.0, NetSuite Advanced Professional Design 4.0 and Aperture for Networks are all viable options for use as a network design and documentation tool. However, in reviewing the needs of the Naval Reserve and the capabilities of the products, it is my opinion that Visio is best suited to meet the specific needs of the Naval Reserve. Visio's ease-of-use, relatively low cost, industry wide reputation and detailed documentation capabilities make it an excellent choice! In the course of doing my research, it has become clear to me that Visio has steadily enhanced its product's features, expanded its capabilities, and has integrated with other third party products in order to increase market share and provide a high quality product at a reasonable cost. A strong argument can be made for using NetSuite because it provides the network design validation as well as extensive documentation capabilities. This can be a very powerful feature that can save time and money. However, this feature is costly and not essential for designing relatively small reserve center LANs. It is the author's opinion Visio's relative ease-of-use and comprehensive business features are a better value!

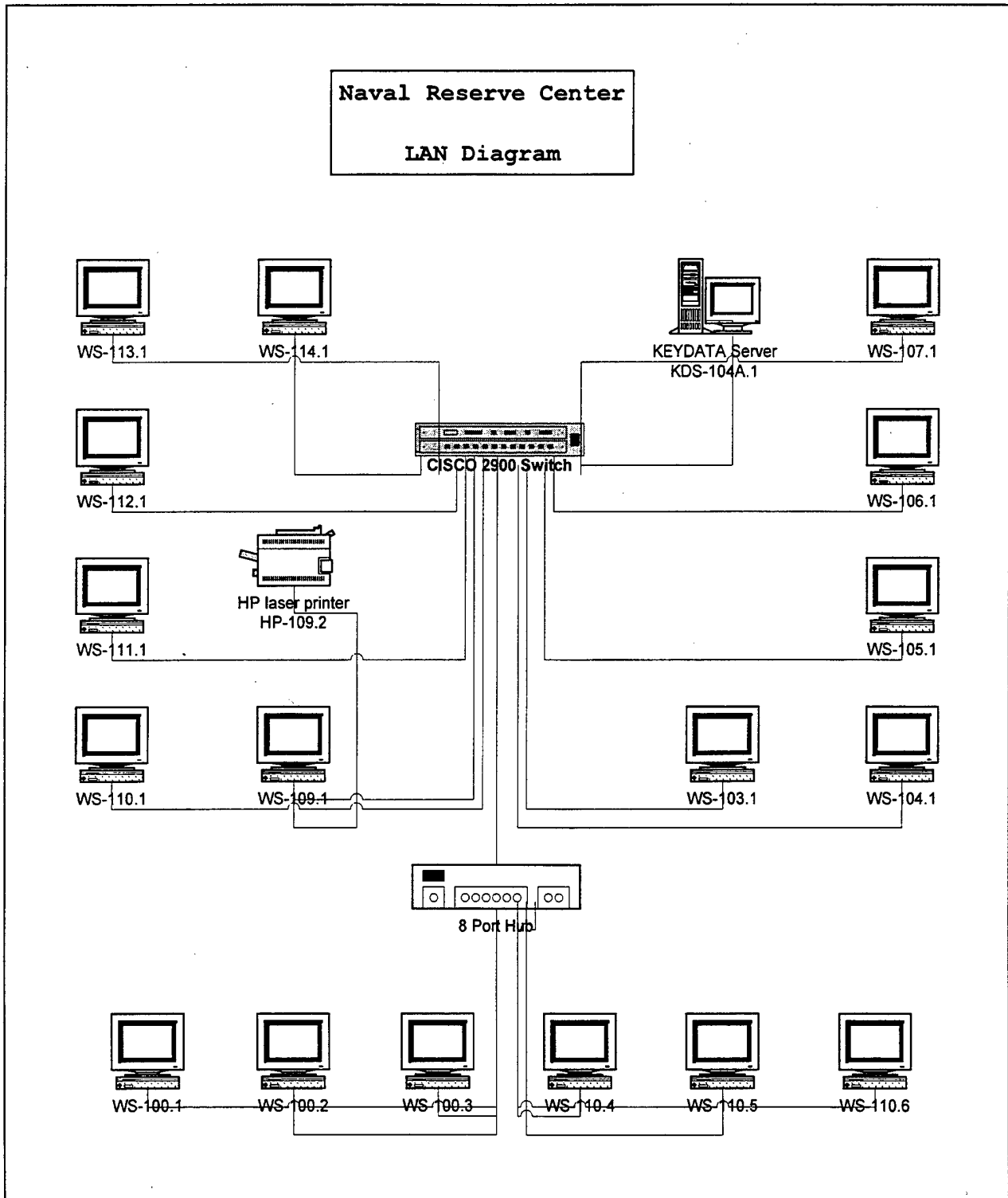

Figure B-1. Sample Logical LAN Diagram.

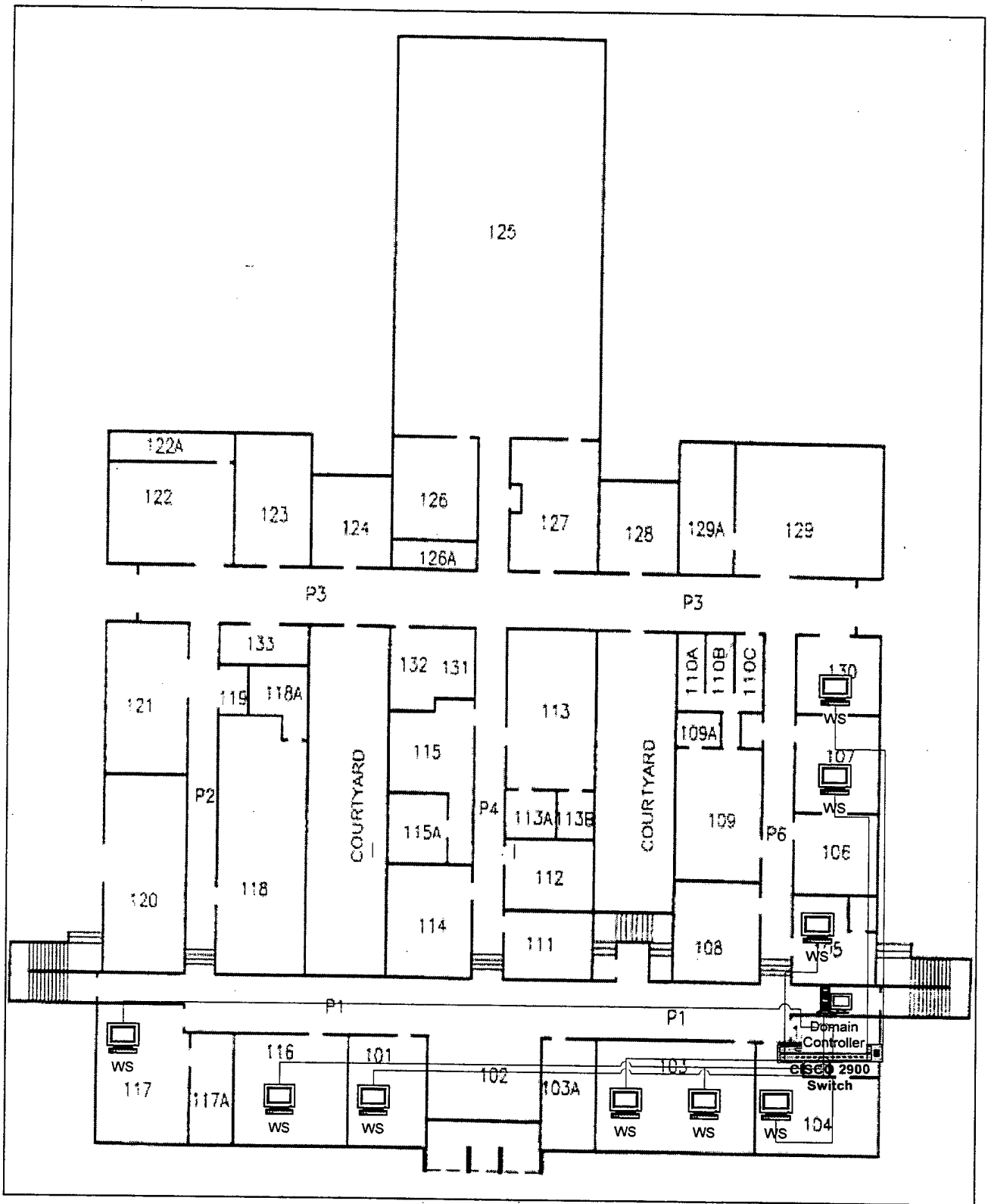

Figure B-2. Sample Visio Diagram.

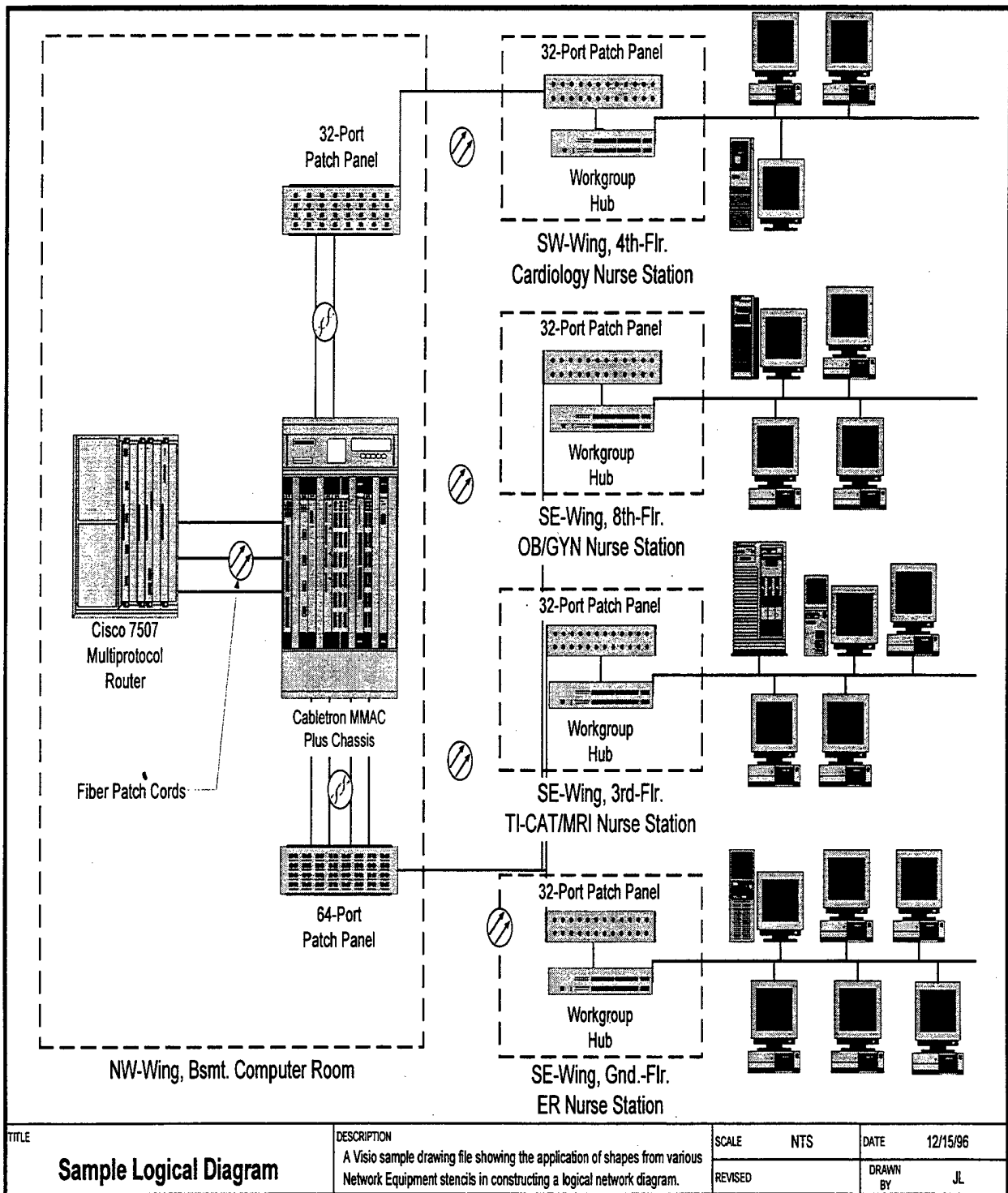

Figure B-3. Sample Visio Diagram [Ref. From Visio Prof. Ver 5.0a, !997]

THIS PAGE INTENTIONALLY LEFT BLANK

## LIST OF REFERENCES

- Adams, S., "The Glass Story," *Technology White Paper*, <http://www.occfiber.com>.
- Chellis, Perkins, and Strebe, *MCSE: Networking Essentials Study Guide*, SYBEX, Inc., 1997.
- Comer, D., *Computer Networks and Internets*, Prentice Hall, Inc., 1999.
- Commander, Naval Reserve Force (CNRF), "Commander Naval Reserve Force Command Presentation,"  
URL:<http://www.navres.navy.mil/navresfor/data/docs/cmd/index.html>, Oct 1999.
- Commander, Naval Reserve Force (CNRF), "Naval Reserve Force Information Technology Vision," [<http://www.navres.navy.mil/navresfor/n6/mission.htm>], 1999.
- Commander, Naval Surface Reserve Force (CNSRF), "Mission Statement," [<http://www.navres.navy.mil/navresfor/navsurf/mission.html>], 1999.
- Commander, Naval Surface Reserve Force (CNSRF), "Surface Master Training Plan Inst. 3502.1C," [<http://www.navy.mil/navresfor/navsurf/n7/n7.html>], June 1998.
- Commander, Naval Surface Reserve Force (CNSRF), "Infrastructure Plan 2000," [<http://www.navres.navy.mil/navresfor/navsurf/ip2000/ip~2000.html>], June 1998.
- Cone, Boggs, and Perez, *Planning for Windows® 2000*, New Riders, Inc., 1999.
- Department of the Navy Chief Information Officer (DON CIO), "Information Technology Standards Guidance (ITSG) Version 99-1," [<http://www.doncio.navy.mil/training/oos/itsg/index.html>], April 1999.
- Department of the Navy Chief Information Officer (DON CIO), "Information Technology Infrastructure Architecture (ITIA) Version 1.0," [<http://www.doncio.navy.mil/training/oos/itia/index.html>], March 1999.
- Hudson, Stewart, and Tittel, *Networking Essentials Exam Cram*, Coriolis Group, LLC., 1999.
- Isabella, L. A., "Managing the Challenge of Trigger Events: Mindsets Governing Adaptation to Change," *Business Horizons*, 1992.
- Kotter, J. P., *Leading Change*, Harvard Business School Press, Boston, MA, 1996.

Microsoft, "Active Directory: An Introduction to the Next Generation Directory Services", [<http://www.microsoft.com/windows2000/default.asp>], Technology White Paper, Microsoft Corporation, 1997.

Passmore, D., "Modeling the Network", *Business Commerce Review*, April 1998.

Passmore, D., "The Need for Architecture", *Business Commerce Review*, February 1997.

Passmore, D., "Developing an Architecture", *Business Commerce Review*, March 1997.

Perkins, C., *Networking Essentials*, SYBEX, Inc., 1998.

Spurgeon, C., "Quick Reference Guide to the Ethernet System," [[http://wwwhost.ots.utexas.edu/ethernet/100quickref/ch1qr\\_1.html](http://wwwhost.ots.utexas.edu/ethernet/100quickref/ch1qr_1.html)], September 1995.

Strebel, P., "Why Do Employees Resist Change?", *Harvard Business Review on Change*, Harvard Business School Press, Boston, MA, 1998.

Thomas, R. M., *Introduction to Local Area Networks*, SYBEX, Inc., 1997.

## INITIAL DISTRIBUTION LIST

1. Defense Technical Information Center.....2  
8725 John J. Kingman Road, Ste 0944  
Fort Belvoir, VA 22060-6218
2. Dudley Knox Library.....2  
Naval Postgraduate School  
411 Dyer Road  
Monterey, California 93943-5101
3. Commander, Naval Reserve Force (N6).....1  
4400 Dauphine Street  
New Orleans, LA 70146-5101
4. Commander, Naval Surface Reserve Force (N6).....1  
4400 Dauphine Street  
New Orleans, LA 70146-5101
5. Commander, Naval Air Reserve Force (N6).....1  
4400 Dauphine Street  
New Orleans, LA 70146-5101
6. Professor Douglas E. Brinkley (Code SM/BI).....1  
Naval Postgraduate School  
Monterey, CA 93943
7. Professor William J. Haga (Code SM/HG).....1  
Naval Postgraduate School  
Monterey, CA 93943
8. Mr. E. Dean Drake.....1  
120 Hillcrest Drive  
Central Square, NY 13036
9. LCDR Dale E. Drake .....2  
126 Moreell Circle  
Monterey, CA 93940