

UNCLASSIFIED

JADS JT&E

JADS Special Report on Distributed Test
Control

By: Earl E. Barnes and Greg Grundhoffer

December 1999

Distribution A- Approved for public release;
distribution is unlimited.

Joint Advanced Distributed Simulation
Joint Test Force
2050A 2nd St. SE
Kirtland Air Force Base, New Mexico 87117-5522

UNCLASSIFIED

20000524 041

DTIC QUALITY INSPECTED 1

AQI00-08-2539

1.0 Purpose and Background

1.1 Purpose

This report describes the Joint Advanced Distributed Simulation Joint Test Force (JADS JTF) test control architecture. It outlines the test control design requirements, test control description, and describes the physical components. Also, this report addresses JADS JTF concerns, and lessons learned. It is intended to provide insight into the process JADS JTF undertook in setting up a distributed test control architecture capable of supporting distributed testing.

1.2 Background

The Joint Advanced Distributed Simulation Joint Test and Evaluation (JADS JT&E) was chartered by the Deputy Director, Test, Systems Engineering and Evaluation (Test and Evaluation), Office of the Under Secretary of Defense (Acquisition and Technology) in October 1994 to investigate the utility of Advanced Distributed Simulation (ADS) technologies for support of Developmental Test and Evaluation (DT&E) and Operational Test and Evaluation (OT&E). The program is Air Force led, with Army and Navy participation.

The JADS JTF is directly investigating distributed test applications in three slices of the T&E spectrum: A Systems Integration Test (SIT) which explores distributed testing of air-to-air missiles, and End-to-End (ETE) test which investigates distributed testing of command, control, communications, computers, and intelligence, surveillance and reconnaissance (C4ISR) systems, and Electronic Warfare (EW) test which explores distributed testing of EW systems.

1.2.1 Systems Integration Test (SIT) Description

The SIT evaluated the utility of using distributed testing to support cost effective testing of an integrated missile weapon/launch aircraft system in an operationally realistic scenario. The SIT also evaluated the capability of the JADS Test Control and Analysis Center (TCAC) to control a distributed test of this type, and to remotely monitor and analyze test results. The SIT consisted of the Linked Simulators Phase (LSP) and the Live Fly Phase (LFP). The missions simulated a single shooter aircraft launching an air-to-air missile against a single target aircraft. The LSP incorporated a manned F-18 avionics lab (simulator) at China Lake NAS as the shooter, a manned F-14 avionics lab (simulator) at Point Mugu NAS as the target, and a missile hardware-in-the-loop (HWIL) simulation lab (simulator) at China Lake NAS which generated AIM-9 missile fly-outs and injected countermeasures (flares). The LFP employed an architecture which incorporated a live F-16 shooter aircraft, a live F-16 target aircraft, and an Advanced Medium Range Air-to-Air Missile (AMRAAM) HWIL simulator hosted in the Eglin AFB Missile Lab.

1.2.2 End-to-End (ETE) Test Description

The ETE test was designed to evaluate the utility of distributed testing to support testing of C4ISR systems. The test used the developmental and operational testing issues for the Joint Surveillance Target Attack Radar System (Joint STARS) in an ADS-enhanced environment to conduct its T&E utility evaluation. Also, the ETE test evaluated the capability of the JADS TCAC to control a distributed test and remotely monitor and analyze test results. The ETE test consisted of four phases. Phase 1 developed or modified the components that allowed a mix of live and simulated targets at an E-8C operator's console and a light ground station module (LGSM) operator's console. Phase 2 evaluated the utility of distributed testing to support DT&E and early OT&E of a C4ISR system in a laboratory environment. Phase 3 moved portions of the architecture to the E-8C aircraft, ensured that the components functioned properly, and confirmed the synthetic environment interacted properly with the aircraft and actual LGSM. Phase 4 evaluated the ability to perform test and evaluation of the E-8C and LGSM in a synthetically enhanced operational environment, using typical operators.

1.2.3 Electronic Warfare (EW) Test Description

The EW test was designed to evaluate the utility of a distributed EW test environment. It consisted of three phases. Phase 1 consisted of open air range and hardware-in-the-loop testing to develop a performance baseline for the two subsequent phases. Phase 2 employed a linked architecture that utilized the Department of Defense's (DOD) high level architecture (HLA) and included a digital system model of the ALQ-131 self-protection jammer, threat simulation facilities, and constructive models that replicated the open air environment. Phase 3 substituted an installed systems test facility (anechoic chamber) with an ALQ-131 pod mounted on an F-16 for the digital systems model. Both phase 2 and phase 3 compared system performance data with live fly data from phase 1 for verification and validation (V&V).

2.0 Test Control Design Requirements

The test control design requirements are broken into four distinct areas: common, SIT, ETE and EW requirements. The common test control requirements were provided by the JADS Steering Committee/Leadership. The individual test team requirements were provided by the JADS test teams.

2.1 Common Test Control Requirements

Situational awareness of a test event is critical if success is the desired result. One difficult challenge facing JADS was to ensure the test director had easy access to all of the information necessary to make the decisions required for proper test execution. With complex systems at different sites interacting, the flow of information in near real-time requires the proper equipment, tools, and people be placed in the ideal locations and the available information be easily transmitted to all parties, especially to the test director. Procedures were developed to control the flow of information to the test director. For the test director too much information is just as bad or worse than little information. Personnel at each site were given the responsibility of providing specific information (system status, data quality, etc.) at predetermined times to the test director.

Discipline by all personnel was important. Rehearsals were used to fine tune the processes. Although the three JADS JTF test programs were investigating the utility of distributed testing in distinctly different environments, the following were common requirements between the tests:

2.1.1 Voice Communications

Communications are common to any form of testing from conventional to distributed test designs. All JADS tests had the requirement to communicate between all participants located in various geographical locations. Most of the facilities used in JADS testing had implemented intricate communication networks to support local testing. Connecting these networks into the JADS communication architecture to support test control presented JADS with a few challenges. Successful distributed test control communications require significant design, planning, and rehearsal efforts. Communications for distributed testing can range from the simple inexpensive solutions such as commercial phone lines to encrypted dedicated communications circuits with larger price tags.

2.1.2 Visual Displays

Since all three JADS test involved the control of live and/or virtual entities, an adequate means of visualizing test events was required. Requirements for each test varied in complexity but the ability to observe the overall scenario/engagement was needed for the test director located in the TCAC. The use of the visual display systems was required for system integration, test rehearsal, and test execution. Having the exact same view of the test space at all sites often enhances the ability of the participants to interact and exchange information since all parties are seeing the same events in the same way. The translation from the view of the local simulation to the virtual test space often introduces errors. When multiple sites interact, the complex behaviors can make it difficult to detect problems if everyone has their own way of viewing the virtual world. Use of these display systems enabled JADS test team to visually identify problems with the operation and interaction of the linked simulations.

2.1.3 Network Monitoring

Distributed testing requires the use of a network to connect the test nodes together. The test nodes used during JADS testing ranged from those separated by over a thousand miles to nodes separated by only a few feet. As a result, the test director needs a means to monitor the status of the network links. The ability to monitor the network in real time allows the test director to control activities at all nodes to maximize testing efforts and minimize expenditures of valuable assets. For the JADS testing the impact of network losses varied from a total loss of testing to minor degradation of test objectives.

2.1.4 Data Transfer

Another common requirement of the JADS test was the ability to transfer large amounts of data to the TCAC from other test nodes. The majority of the data transferred was used for detailed analysis not associated with test control. A critical portion of the data was needed to support the test director in making decisions that affected the conduct of a current test or the scheduling of the next test event. Rapid access to this data was key in preventing the expenditure of valuable test time.

2.1.5 Test Control Procedures

The development and use of detailed test control procedure was common to all JADS test. Although the procedures vary from test to test the goal was to have a thorough and practiced method to control the test event. Development of these procedures were included in the planning process from the start. For all test, JADS personnel used risk reduction and integration test to refine draft test procedures. This refining process continued between all test phases. Development of test control procedures included key members from all test sites to ensure an understanding of site requirements and existing procedures.

The test procedures for the JADS test efforts can be found in the following References:

1. Systems Integration Test, Linked Simulators Phase, Final Report, Joint Advanced Distributed Simulation Joint Test and Evaluation, Albuquerque, New Mexico, July 1997
2. Systems Integration Test, Live Fly Phase, Final Report, Joint Advanced Distributed Simulation Joint Test and Evaluation, Albuquerque, New Mexico, March 1998
3. End-to-End Test Interim Report Phase 4, Joint Advanced Distributed Simulation Joint Test and Evaluation, Albuquerque, New Mexico, August 1999
4. Electronic Warfare Test Interim Report Phase 3, Joint Advanced Distributed Simulation Joint Test and Evaluation, Albuquerque, New Mexico, November 1999.

2.2 Systems Integration Test (SIT) Test Control Requirements

The SIT test control requirements differed between the SIT LSP and the SIT LFP test events. Test control had to support the following:

2.2.1 Linked Simulator Phase (LSP) Test Control Requirements

1. Unclassified conference call network to support up to 10 phones for:
 - a. Ordering start/stop of each simulation
 - b. Ordering start/stop of data loggers
 - c. Directing simulation pilots engagement
2. Classified STU-III phone capability between three sites (Pt Mugu, China Lake

and TCAC for discussion of classified issues.

3. 2-D display of target/shooter/missile engagement in the TCAC.
4. Display capability of target/shooter dynamics in the TCAC (speed, heading, G's, altitude, range to target, closing speed,)
5. Quick-look analysis capability to verify proper execution of last engagement.

2.2.2 LSP Network Description

Figure 1 details the SIT LSP communications network. The involved facilities at Point Mugu, CA and China Lake, CA were already linked together through the Naval Air Warfare Center Weapons Division (NAWCWPNS) Real-Time Network (NRNet) at Point Mugu. JADS JTF leased a T1 line from Albuquerque, NM to Point Mugu, CA and connected into the NRNet at the Sea Range Communications Center. Because of latency concerns and NRNet traffic loading, the missile simulator and F/A 18 Labs at China Lake had to connect their MIL STD 1553B Data Busses via a separate data circuit in order to get proper interaction between the F/A 18 weapons control system and the missile launch control system. Refer to Reference 1 for detailed network diagrams and test description.

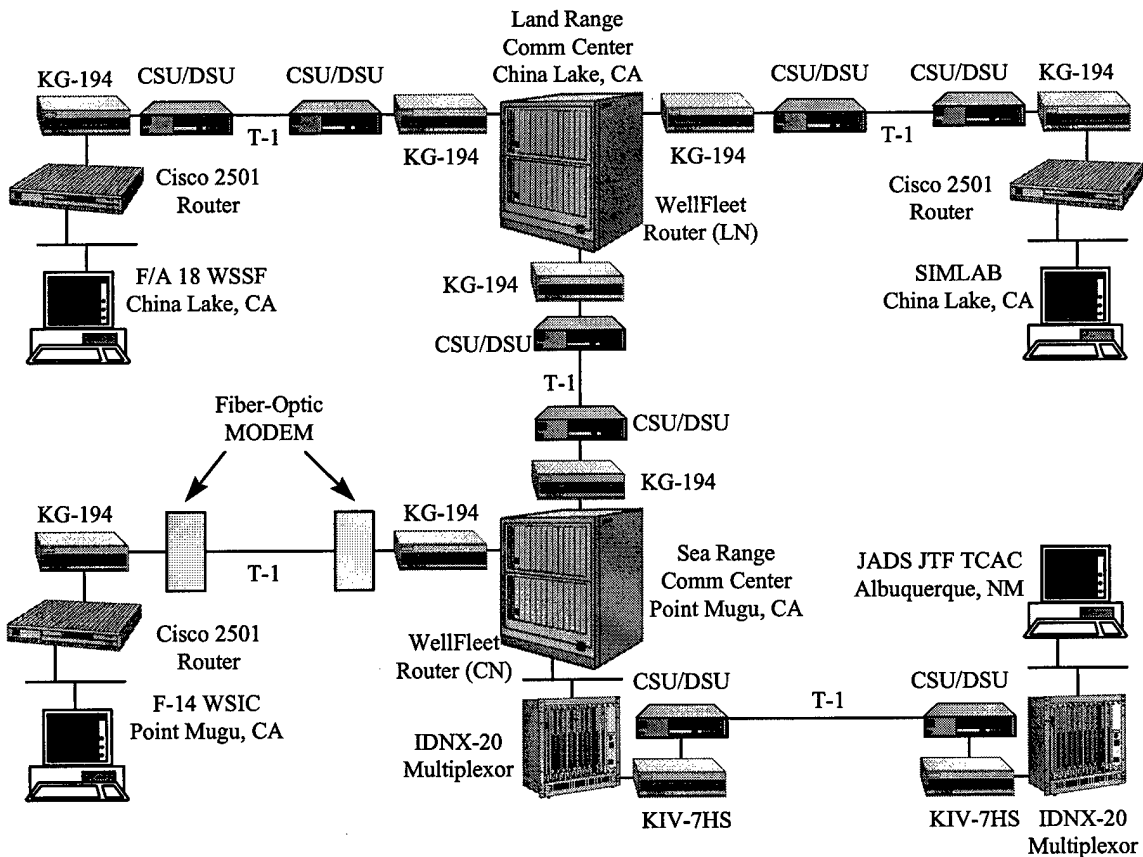

Figure 1 SIT Linked Simulator Phase Network

2.2.3 Systems Integration Test (LSP)

Test control procedures were designed for simplicity and decentralization of control. The design of the test required the shooting aircraft to achieve a certain geometry where altitude, airspeed, range to target, target aspect, missile pointing angle and target acceleration were simultaneously achieved. The only way these conditions could be repeated consistently was if the shooter pilot controlled the entire intercept. To reduce the number of variables he had to deal with, the shooter pilot was "unfrozen" at a specified distance aft of the target with approximately a half mile of lateral separation. After both simulators were reset and frozen, the target simulation was started. The shooter watched his HUD as the target range opened. When he saw the range to target he wanted, he unfroze his own simulation. This procedure was used instead of simultaneously unfreezing both simulations since the time required to unfreeze the target simulation took from less than a second to up to 3 seconds. This procedure permitted the shooter to achieve a consistent starting geometry without having to make a difficult and time consuming speed adjustment to achieve proper range. The initial altitude difference and lateral separation were determined by trial and error.

When the test controller saw both aircraft "flying," he called for the target to turn and cross in front of the shooter (see Fig.3). The target then flew a turn at constant speed, altitude and turn acceleration. This flight path, combined with the initial conditions of each simulator, allowed the shooter to achieve the desired range and aspect parameters with little maneuvering.

Once the test controller had started the target turning, achieving the desired geometry was totally under the control of the F/A-18 pilot. After the missile finished its flyout the test controller terminated the run and released the simulators to reset following any quick look procedures they needed to perform.

All analysts were located in the SIMLAB where the data from the missile were presented. The only communication required from the SIMLAB was a statement on whether the run was acceptable or not. This control approach resulted in minimal communications on the unclassified command voice circuit. For a more detailed explanation and description of the LSP test effort refer to Reference 1 (SIT, LSP Final Report).

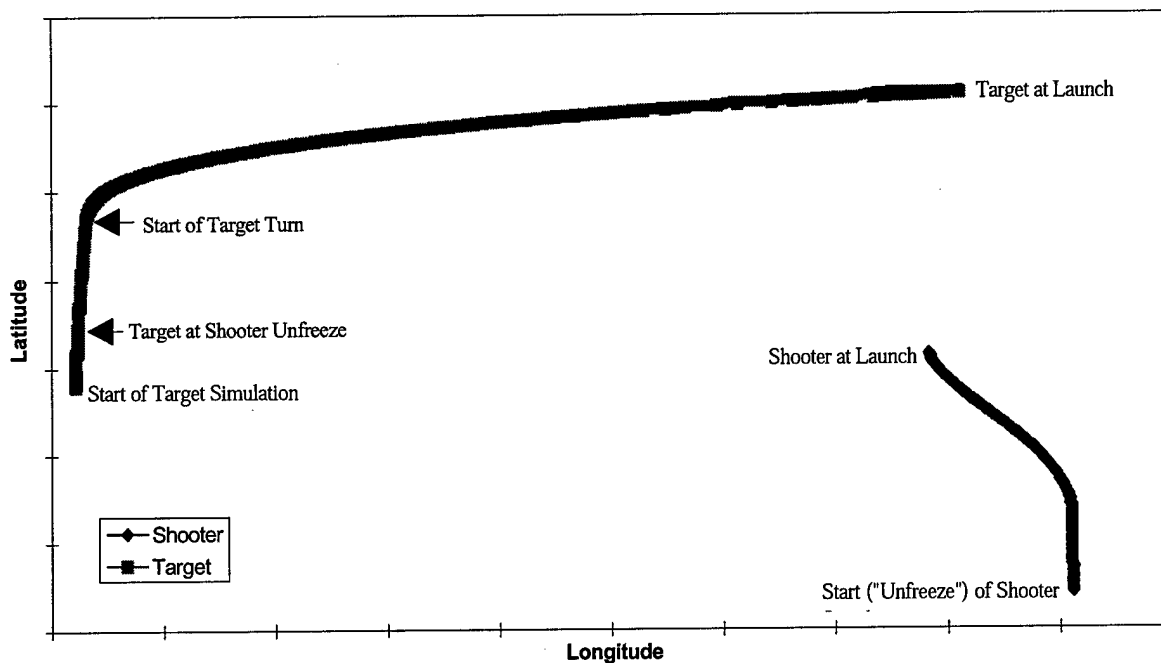

Figure 3 (Pre-Launch Shooter and Target Trajectories (Run #9 on 11/19/96) - "God's-Eye" View)

2.2.4 Test Monitoring Displays

Two separate displays were developed to permit effective control of the tests and to evaluate how well each intercept was performed.

- The first display was a two-dimensional ("God's-eye") stealth viewer. Entity state PDUs from the two aircraft and the missile, after it was fired, were displayed on a screen showing an outline of the China Lake restricted airspace. Since both players were virtual, the exact location did not matter. Each entity was represented by a friendly or hostile symbol with an aspect vector whose direction represented the entity heading and whose length was proportional to the speed. Each entity created a "trail" of points representing its flight path. Because the LSP was attempting to replicate a single profile, the ground track for each run essentially overlaid the tracks of the previous runs. This provided a useful capability for making a first cut evaluation of how well the intercept and flyout replicated the desired trajectories.
- The other "discretes" display showed various parameters which defined the "shot box." Target altitude, mach number, and turning acceleration, long with shooter altitude and mach number were displayed in strip chart format with a total of 16 seconds of history trace visible at a time. A horizontal blue line was displayed continuously for the desired value for each parameter throughout the period when the instantaneous value was being displayed. A digital readout for each parameter was also provided. When each parameter fell within the desired range of values which defined the shot box, the digital readout turned from white to green.

The speed with which the shooter was closing on the target (V_c) was also displayed in this manner; however, this parameter turned out not to be useful.

The radar mode and status of master arm power and the trigger were listed in gray and turned green when selected or the trigger was squeezed.

Range to target was shown to one decimal place of precision. The numbers were green when within the desired range.

The true heading of each aircraft was displayed in digital format.

Two circular displays showed (a) where the radar was pointing relative to the nose of the aircraft both in azimuth and elevation and (b) the angle between the nose of the target and the line-of-sight to the shooter (i.e., the target aspect angle).

The radar pointing angle was used as a reasonably close measure of how far off boresight the missile seeker was pointing since the seeker was slaved to the radar line-of-sight at launch.

Each display turned from white to green when the particular parameter met acceptable launch conditions. This provided a very simple and accurate method of determining whether the particular run met the desired parameters. However, the final decision on whether to count the run as "in the shot box" rested with the analysts in the SIMLAB.

2.3 Live Fly Phase (LFP) Test Control Requirements

1. Unclassified conference call network to support up to 10 phones for:
 - a. Ordering start/stop of data loggers
 - b. Communication between test controller in TCAC and Test Director located at the CCF.
2. Classified STU-3 phone capability between three sites (CCF, MISILAB and TCAC for discussion of classified issues.
3. Internal communications at the CCF between JADS Test director and the aircraft controller.
4. 2-D display of target/shooter/missile engagement in the TCAC.
5. Quick-look analysis capability to verify proper execution of last engagement.

2.3.1 LFP Network Description

Figure 3 details the SIT LFP communications network. The involved facilities at Eglin AFB, FL built a network infrastructure in order to meet the SIT LFP requirements. JADS JTF leased a T1 Line from Albuquerque, NM to Eglin AFB, FL and connected into Eglin's network at the Central Control Facility. The network required minor changes once all of the components were installed

in order to optimize network performance and meet the LFP network requirements. Refer to Reference 2 for detailed network diagrams and test description.

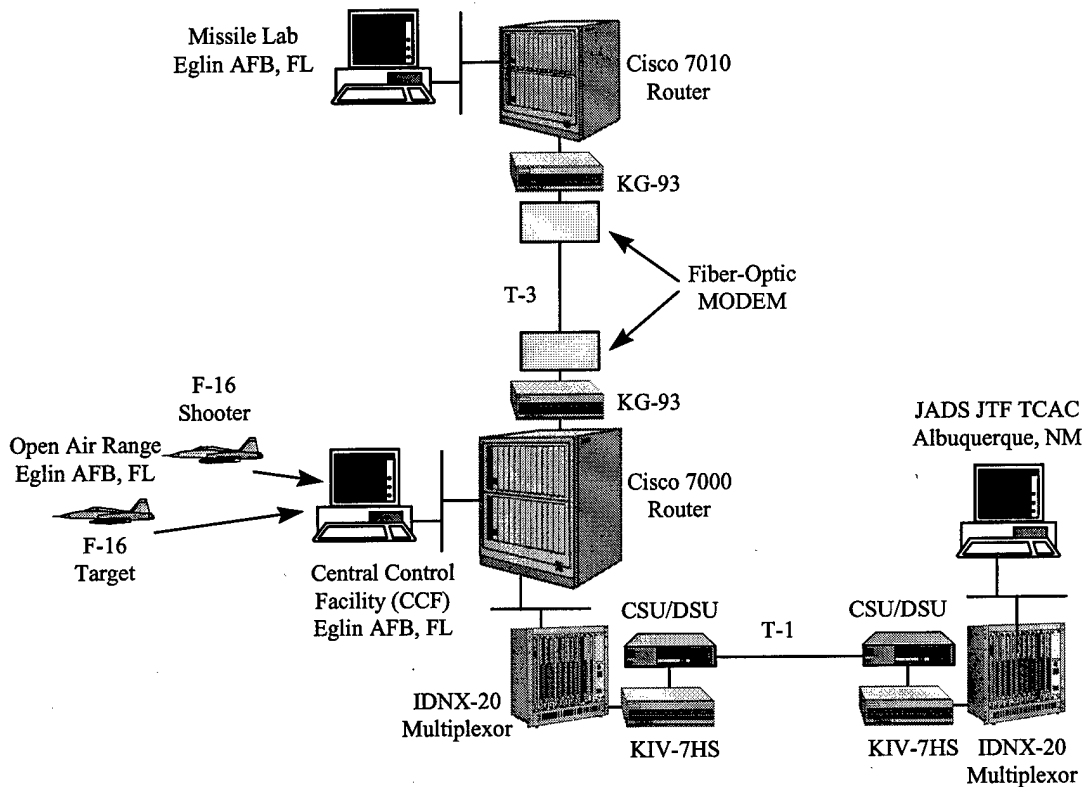

Figure 3 SIT Live Fly Phase Network

2.3.2 Control Procedures

Test control was centralized at the CCF, rather than the TCAC, due to the following factors:

- The live aircraft had to be controlled by air traffic controllers from the CCF (due to range policy which was driven primarily by range safety issues).
 - During the LSP, test control was centralized in the TCAC, and the test controller in the TCAC provided positive control of the pilots "flying" the aircraft simulators. This control was made possible by real-time data and position displays in the TCAC. Also, there were no flight safety concerns since only simulators were being used.
 - Air traffic controllers could not exercise safe control of the aircraft from the TCAC. Entity state data used to drive the aircraft position displays in the TCAC had too much latency for safe aircraft control (nearly 2.5 seconds of latency, as Table 4.3.4.3-1

shows). Further, auxiliary data on range weather conditions and other live aircraft in the test area were not available at the TCAC.

- Communications with the key participants was most effectively exercised from the CCF. The JADS test director, the test conductor, and the CCF coordinator (see next paragraph) had direct physical contact at the CCF and communications links to the other nodes.

Test control centered on three individuals located at the CCF:

- JADS test director (SIT Team Lead): Determined next test profile and informed test conductor. Made decisions on any changes to planned profiles and on when to terminate the mission. All nodes within the LFP architecture had on-scene JADS representatives with the ability to speak to the team lead in the CCF. This provided the team lead with the potential capability to react and affect the conduct of the mission in a real-time manner.
- Test Conductor: Announced the start and stop of each pass, the flight profile to be executed (i.e., test card number), and the pass number to the CCF control net and to the air traffic controllers. The air traffic controllers relayed this information to the pilots and vectored the aircraft to starting positions for each pass.
- CCF Coordinator: Relayed the "30 seconds until pickle" warning from the test conductor to the MISILAB. Polled players on results of each pass.

For a more detailed explanation and description of the LFP test effort refer to Reference 2 (SIT, LFP Final Report).

2.4 End-to-End (ETE) Test Control Requirements

The ETE test control had to support the following:

1. Unclassified conference call network to support up to 10 phones for:
 - a. Ordering start/stop of data loggers.
 - b. Communication between the Northrop Grumman SATCOM operator and the TCAC.
 - c. Communication between test controller in TCAC and test director located at FT Hood.
2. Classified T-1 phone capability between three sites (Northrop Grumman, FT Hood and TCAC for discussion of classified issues.
3. Unclassified T-1 phone capability between four sites (FT Hood, FT Sill, TRAC WSMR and the TCAC
4. HF and UHF radio link between the test director at FT Hood and the JADS team member onboard the E-8C.

2.4.1 End-to-End Test Network Description

Figure 4 details the ETE communications network. The ETE test also presented the challenge of transmitting data from an unclassified site into a classified network. This was accomplished by configuring a one way only link at the JADS facility. JADS JTF received unclassified (non-secure) data from White Sands Missile Range (WSMR), NM, and Ft. Sill, OK and forwarded that data into the TCAC, and prevented any data from the secure network propagating to the non-secure network.. Refer to Reference 3 for detailed network diagrams and test description.

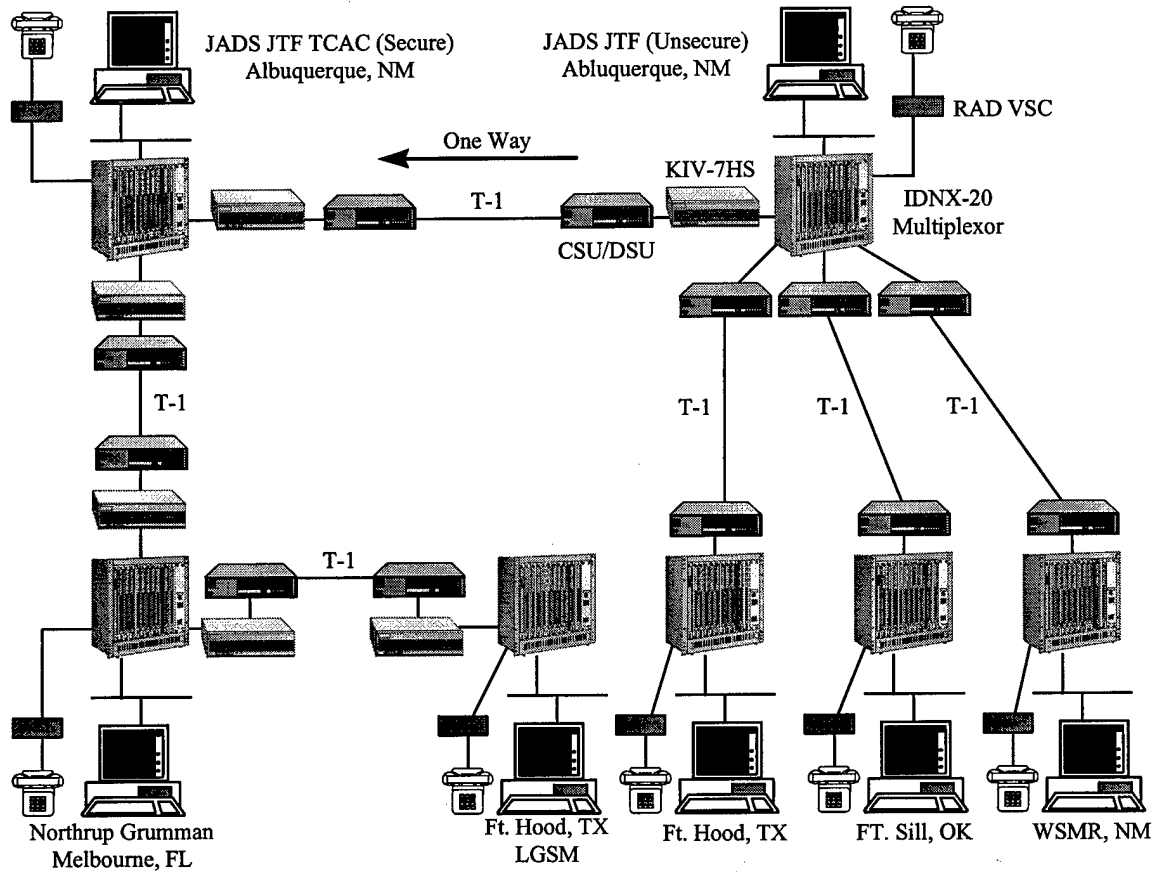

Figure 4 ETE Test Network

2.4.2 Test Control and Monitoring

During Phase 4, ETE Test and Network and Engineering team members performed test control from the TCAC. Test control consisted of three major areas -- network monitoring, communications, and test procedures.

The Network and Engineering team conducted network monitoring in the TCAC using hardware and software tools. The software consisted of commercial products and test-specific tools developed by JADS analyst/programmers. They used the following systems.

- Silicon Graphics, Inc. (SGI) Indy - JADS logger
- SGI Indy - time server

SGI Indigo - NETVisualizer™
SUN SPARC 5 - Spectrum™
Line printers

JADS analyst/programmers developed the JADS logger. This software recorded all PDU traffic at individual sites as well as displaying the PDU rate in real time. All nodes, with the exception of Fort Hood, had a JADS logger installed. All traffic into and out of Ft Hood was transmitted using tactical protocols and formats rather than DIS. Each tactical system had some level of logging of internal operations, however, these databases or reports proved to be of minimal use to the test team. The JADS logger recorded the receipt of the PDU and time stamped it using an accurate time source. These data were used to analyze PDU transmission performance over the network.

JADS analyst/programmers also developed a time server which provided the accurate time source needed for the JADS logger. The time server was tied to a global positioning system (GPS) receiver located in the TCAC and provided time to all instrumentation nodes with an accuracy of 100 microseconds. The software also contained monitoring tools to track the time servers performance over an 8-hour test period.

Cabletron Spectrum™, NETVisualizer™, and line printers were used to provide network monitoring. Spectrum™ measured bandwidth utilization. This tool recorded the percentage of bandwidth used, as well as bandwidth loading on a network segment. NETVisualizer™ software displayed real-time bandwidth use in a rolling bar graph format for quick visual reference. The line printers provided a printout of network router status. Any failure or high bit error rate resulted in a printout showing the problem and identity of the offending router.

Communication among the distributed ETE Test nodes was critical. The TCAC provided all needed communication systems. Dedicated phone circuits, residing on the T-1 lines, provided classified and unclassified service. The unclassified line allowed connectivity among the TCAC, Fort Hood, Fort Sill, and TRAC-WSMR. The classified line allowed connectivity among the TCAC, Fort Hood, and Northrop Grumman. These lines allowed the operator to select the desired site, lift the receiver, and connect directly to that site. The TCAC could select multiple sites for conference calls on these lines. In addition to these lines, the ETE Test team used an unclassified conference line to coordinate such test events as network checks and after-action debriefs. This line allowed up to ten participants to connect at one time.

There were additional requirements to communicate between the E-8C and the test director on the ground at FT Hood. Secure HF and UHF links were established between the JADS test team member onboard the aircraft when the aircraft arrived on station over FT Hood. The JADS member communicated the status of the test as well as any problems to the test director. This communication link was also used by the JADS analyst to coordinate data collection onboard the E-8C and the LGSM located at FT Hood. Communications between the E-8C and Northrop Grumman SATCOM operators located at Melbourne, Florida was accomplished via a HF link or by using text message traffic over the SATCOM link. These links were used to communicate the status of the SATCOM link and to coordinate the start of the scenario with the test controller in the TCAC.

Test procedures were required to provide effective control of all test nodes during test events. The test procedures were in checklist format, which provided for standardization among the distributed nodes. The network checklist was most critical and was used to initialize the network before the test. Other checklists included those used to start up hardware and software at individual nodes, as well as the checklist used by the TCAC test controller to start and stop the overall test.

For a more detailed description and explanation of the ETE test effort refer to Reference 3 (ETE Test Interim Report Phase 4).

2.5 Electronic Warfare (EW) Test Control Requirements

The EW test control had to support the following:

1. Unclassified conference call network to support up to 10 phones for:
 - a. Test briefs with all participants.
 - b. Off line communications between multiple sites
2. Classified phone capability between three sites (AFEWES, ACETEF and TCAC) for test control and discussion of classified issues.
3. Visual display of engagement for test director/controller.
4. Quick-look analysis capability to verify proper execution of last engagement.
5. Visual display of Federate health status

2.5.1 Electronic Warfare Test

Figure 5 details the EW communications network. The EW test presented many challenges in the networking equipment's configuration. Although the EW test was able to utilize the same equipment as SIT and ETE, the network equipment required extensive configuration changes in order to optimize the routers' performance while reducing transmission latency to minimal levels. Refer to Reference 4 for detailed network diagrams and test description.

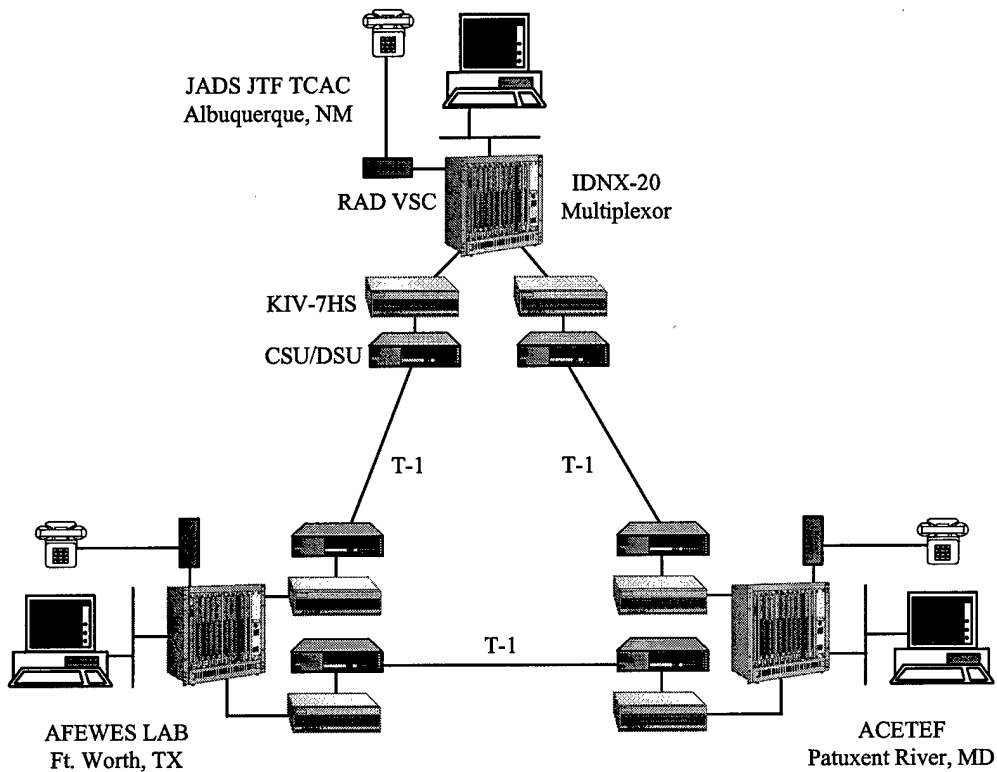

Figure 5 EW Test Network

2.5.2 Test Control

Test control is an important aspect of any formal test environment. To insure that test conditions and status were monitored and maintained in a distributed, ADS-based test environment, JADS had to carefully define its requirements. Areas addressed included test control, unique real-time status reporting and display capabilities, and test control procedures within the TCAC as well as AFEWES and ACETEF. Critical components of the Phase 3 test control included federation time synchronization, federation startup, and status monitoring described below. For a more detailed description and explanation of the EW test effort refer to Reference 4 (EW Test Interim Report Phase 3).

2.5.3 Federation Time Synchronization

All computers used for the Phase 3 test used a common time source to insure valid time values were recorded in the logs at all sites during test execution. Prior to the start of daily testing, a time synchronization test was run by the TCAC to verify that all computers were using the correct, accurate time source (IRIG-B) in their operations and not running on local internal

system time. All JADS federates except AFEWES and the Analysis Federate participated in the time synchronization test. Since the Analysis Federate only read and recorded data, it recorded time synchronized data from other federates. Time synchronization was performed by initiating a normal run and after a jamming response was observed in the TCAC the execution was stopped. JADS copied the TCF log file to the appropriate log file directory and ran the logfile_summary program on the file. The recorded times for all messages in federate log files were checked to look "reasonable" (within +/- 20 milliseconds of each other). The times recorded on the Link Health Check messages showed the time on all of the SGI O₂s. Execution control messages (Start and Stop) showed the time for the ADRS 2 PC. The time recorded on the X_File_Spec message showed the time for the ADRS 1 PC. The time recorded on the SUT messages showed the time for the Jammer federate.

The AFEWES computers were also synchronized to an IRIG-B time source. Software executed on the AFEWES computers synchronized the system time to the IRIG-B time. The AFEWES federate software used the system time as its time source. To determine if AFEWES is synchronized, JADS would run the raw TCP test program previously used for RTI testing. Upon completion, the receiver printed out the minimum, maximum, and mean latency. JADS verified that the latency was "reasonable". A real-time analysis capability was not available to determine if all systems maintained time synchronization during test runs. However, during subsequent data analysis the quality of time synchronization was able to be determined.

2.5.4 Federation Startup

During the previous integration tests for the Phase 2 test, it was determined there were less data dropouts if the Platform federate was not the first federate to join the federation. Since five federates in the TCAC were all subscribing to most of the same reliable data, DMSO technical support recommended that JADS execute with a single reliable distributor for the TCAC. Normally, each federate contained a reliable distributor to send and receive reliable data. There was a TCP connection from every reliable distributor to every other one. By configuring the TCAC federates to use one reliable distributor, the number of TCP connections and the subsequent traffic on the WAN was reduced. The RFENV federate did not have much data to process, so it was chosen as the host location for the TCAC reliable distributor (RELDISTR). The federate containing the reliable distributor started the federation executive (FEDEX) and joined the federation first. It was observed that if the FEDEX was not started on the same computer where the RTI executive (RTIEXEC) was running, it would take a few minutes for the FEDEX to find the RTIEXEC.

After the RFENV federate started and joined the federation, all of the other federates in the TCAC would join (staggered by a second or two). After the TCAC federates successfully joined the federation, the remote federates (AFEWES and Jammer) joined.

2.5.5 Federate Status Monitoring

The Link Health Check display as well as the FEDEX window were monitored during federation execution. If there were problems, generally one of these windows displayed an indication. For

example, the Link Health Check status display on the TCF screen indicated federate status as red or green. It provided the capability to monitor specific multicast traffic paths in one direction only between any two federation nodes (e.g., JADS - AFEWES). The FEDEX window monitored the RTI's "heartbeat" messages over the reliable (TCP) data paths. The federate displayed red if the federate stopped sending Link Health messages due to software error or a failure in the link. However, the problem was generally noted by one of the remote sites before the TCAC federates exhibited a corresponding display. This was due to the fact that the TCAC had fewer indications of information outages from other nodes. The link health and FEDEX windows could only detect outages that occurred over an extended period of time (> 3 seconds for link health, 20 seconds for FEDEX). Status monitoring procedures of individual federates and operator procedures are described below in further detail.

2.5.6 Jammer (ACETEF) Operation

For phase 3, the facilities at ACETEF hosted the ALQ-131 jammer. The ACETEF Jammer federate operation involved two major activities for each test run.

The first activity managed the local processes to successfully join the federation and begin accepting data. This complex procedure consists of several steps. The first step was to run a script which started the Link Health Check Monitor, the Emitter Monitor, a graphic visualizer called "TacPlot", SWEG, and the RTI and SWEG interfaces, which comprised the ACETEF HLA interface. Immediately, SWEG would begin polling for "external assets" and continued to do so until all external assets were "ready". The external assets consisted of: the emitters being controlled by ATEWES, the HLA interface, SWEG or TacPlot graphics, and the asset to asset communications. The RTI interface immediately polled the user for the run number, set up a shared memory connection with the SWEG interface, started the JADS logger file, joined the FEDEX, published and subscribed to all expected data, and finally rested in a pattern of polling the RTI for a start command (issued by TCAC) and broadcasting the status of the federate. The SWEG interface meanwhile, established its shared memory connection to the RTI interface and waited for the start command issued by the RTI interface.

The ACETEF federate operator then vocally authorized the ATEWES operator to start, and once ATEWES came on line, SWEG recognized this and passed to its next waiting step. SWEG status was then waiting for a "start execution" order from the SWEG Interface.

The ACETEF federate operator informed the JADS TCAC that ACETEF was ready for the start. Another good visual queue that ACETEF was ready for the start command was when the SWEG graphics screen was displayed.

JADS then sent the start command from the TCAC, which was received at the RTI Interface and passed to the SWEG Interface, which, in turn, then sent SWEG the "start execution" command. At this point, SWEG graphics would appear and the federate, and the federation, entered "run" mode.

The operator monitored the integrity of the federation with the tools available to him at ACETEF. This included the Link Health Check Monitor, the Emitter Monitor, SWEG or TacPlot graphics, and warning or dropout message information displayed on screen by the RTI Interface. The Link Health Check monitor indicated federate status and link check between federation nodes by red or green coloring. The emitter monitor displayed the different emitters used in the scenario and their respective modes of operation were indicated by red or green coloring. Warning or drop out messages were displayed to indicate missing and out of sequence data. If necessary, dead reckoning smoothed lost TSPI data. SWEG graphics or TacPlot were used for test execution control.

At the end of the run, the ACETEF federate operator shut down the Link Health Check and Emitter Monitors, the RTI and SWEG Interfaces, TacPlot, and SWEG. The ATEWES operator shut down the ATEWES.

At the end of each test day, the ACETEF federate operator collected all log files and organized them into permanent directories. The ACETEF's federate logger file, the ATEWES timing file and the ATEWES dx file were all collected. These files consumed many megabytes of storage.

2.5.7 Test Control Federate (TCF) Operation

The TCF, located in the TCAC, started by executing a shell script. When the federate started, it prompted the operator for a run number. After the operator entered a run number, the federate prompted the operator to join the federation. When directed by the JADS test controller, the operator entered the federation. When the TCF completely joined the federation, the ADRS software was started by the ADRS operators on each of the three ADRS PCs. The software on each PC started a few seconds apart from each other to help prevent the TCF federate from periodically crashing. Once the ADRS software was running, the federate waited for Execution_Control commands from ADRS. When an execution control attribute was received, the TCF federate published it for the other federates. The script names and the start and stop messages were sent to all of the federates using this method. When the command was an Execution_Control attribute with an Execution_Control_Word that indicated stop test execution, the TCF federate published the attribute and then resigned from the federation.

2.5.8 Platform Federate Operation

The Platform federate located in the TCAC started by executing a shell script. When the federate started, it prompted the operator for a run number. After the operator entered a run number, the federate prompted the operator to join the federation. When directed by the JADS test controller, the operator entered the federation. The Platform federate waited until it received an attribute update that contained the name of the script to be loaded. When it received the script name, the federate displayed the name of the script being loaded. The federate then waited for an execution control attribute update with that indicated the start of test execution.

During a federation execution, the Platform federate executed without operator intervention. The window in which the federate executed was monitored for error messages. The Platform federate

played its script until an execution control attribute update was received that indicated stop of test execution. The federate then resigned from the federation.

2.5.9 Radio Frequency Environment (RFENV) Federate Operation

The RFENV federate located in the TCAC started first because it created the federation execution (FEDEX) and the reliable distributor (reldistr) used by all federates in the TCAC. The RFENV federate started by executing the a shell script. When the federate started, it prompted the operator for a run number. After the operator entered a run number, the RFENV federate created the FEDEX. The federate then prompted the operator to join the federation. The operator entered a 'y' at the prompt so that the federate joined the federation. The RFENV federate waited until it received an attribute update that contained the name of the script to be loaded. When it received the script name , the federate displayed the name of the script being loaded. Upon completion of script loading, the federate displayed "done". The federate waited for an "execution control attribute" update that indicated start of test execution.

During a federation execution, the RFENV federate ran without operator intervention. The operator monitored the window in which the federate executed for error messages. The FEDEX window was also monitored for error messages indicating loss of contact with other federates. The RFENV played its script until an execution control attribute update was received that indicated the stop of test execution. The RFENV federate waited for all other federates to resign from the federation and then resigned from and destroyed the federation execution. If there were problems with any federate resigning, the federation was destroyed manually by entering a "kill" command in the FEDEX window.

2.5.10 Terminal Threat Hand-Off (TTH) Federate Operation

The TTH federate located in the TCAC started by executing a shell script. When the federate started, it prompted the operator for a run number. After the operator entered a run number, the federate prompted the operator to join the federation. When directed by the JADS test controller, the operator entered the federation. The TTH federate waited until it received an attribute update containing the name of the script to be loaded. When it received the script name, the federate displayed the name of the script being loaded. Upon completion of script loading, the federate displayed "done". The federate then waited for an execution control attribute update with an Execution_Control_Word indicating the start of test execution.

During a federation execution, the TTH federate executed without operator intervention. The window in which the federate executed was monitored for error messages. The federate played its script until an execution control attribute update was received that indicated the stop of test execution. The TTH federate then resigned from the federation.

2.5.11 AFEWES Threats Federate Operation

The AFEWES threats federate consisted of federate software hosted on an SGI computer, and facility unique systems and software for scenario status control and display, test management

centers, and operator consoles. AFEWES controlled the test run execution and individual systems from a central facility linked internally by intercoms with external voice links to JADS and ACETEF. The test controller at JADS advised the AFEWES controller by voice for federate and run start and stop conditions similar to the ACETEF federate. The AFEWES controller then coordinated internal execution actions with operators and advised JADS of current status.

2.5.12 Analysis Federate Operation

The Analysis federate provided an improved scenario viewer for observing north and south bound test runs and specific threat engagements. It showed the specific modes a threat site used, and missile flyouts as they occurred. Real-time displays of the 10 EW MOPs, and the real-time values of jamming-to-signal ratio and tracking error were provided for situational awareness of each threat engagement with the target aircraft. Data collection and storage for the Analysis federate were nearly automatic, and required little operator intervention once the run started. Once the federation began, the Analysis Federate operator waited to join the federation. Queued from the TCF operator, the Analysis Federate joined the federation and awaited the start of the test execution. During the run, the window was monitored for errors in the threat performance or variance in the threat operators. Once the test execution completed, the operator resigned the Analysis federate from the federation and immediately restarted the software to begin the next run.

3.0 Equipment Descriptions

3.1 Voice Communications

3.1.1 Voice Networks

The JADS tests had a requirement that all participants be able to communicate in a conference call. Two alternatives were used to satisfy the conferencing requirement. Existing unclassified conference bridges were used for the SIT and ETE tests. The conference bridges were provided by the base/post communications center or by one of the test facilities. All personnel would call into the conference bridge at specified times. A means of calling an unscheduled conference had to be determined. This involved using standard point-to-point calls, beepers, and computer talk sessions.

3.1.1.1 Conference Bridges

The SIT required multiple conference calls: one for the pilots and controllers and one for the test controller, site observers, and data collection personnel. For the SIT LSP, the conference bridge was supplied by NAWCWPNS. For the SIT LFP the test control voice network was used for pilots and aircraft control. An unclassified conference bridge capability provided by the Kirtland AFB communications squadron was used for site observers and data collectors.

For the ETE test, a single conference call was used by all participants. Unlike the SIT and EW tests, the conference calls were not held throughout the duration of the test. Since a test period was typically 7 hours in duration with little interaction, this would have been impractical. Conferences were held at predetermined times before a test in order to brief all participants and startup the simulations and live players. Point-to-point calls were used throughout the duration of the test to talk with individual sites. Problems would require that all participants join a conference call. The time zone differences, along with the long duration of test events, often made it difficult to assemble all of the participants during the day.

3.1.1.2 Dedicated Voice System

The ETE and EW test utilized a portion of the available T-1 bandwidth to establish dedicated secure communications between all the sites. This was implemented using quad analog voice processor modules in our integrated digital network exchange (IDNX) communications resource managers and RAD voice signal converters (VSC) to pass voice on the dedicated JADS WAN. Each link had two voice channels connecting each site to the others. This reduced the bandwidth available for data by 128 kilobits. The conferencing capability built into the telephones was used to connect all sites in one conference call. The "JADS Special Report on Network and Engineering," August 1999, has a more detailed description of the IDNX and VSC hardware.

The dedicated voice systems provided a hot-line capability between the sites. The originator of a call only needed to lift the handset, or push a single button and he would be connected to the desired site - usually to the JADS representative at the site.

The second conference call method used the conference feature on multi-line phones connected via the dedicated T-1 circuits connecting the facilities. This solution had the advantage of being secure since all traffic was sent through the cryptographic equipment and used the JADS WAN links. The disadvantage was that it was more prone to quality and procedural problems. This method was very sensitive to who initiated the call, and it required that everyone be diligent about hanging up after a call. The EW test used this method as the primary voice system for test control. The EW test used this method between the TCAC, AFEWES and ACETEF. At each of these facilities this phone connection was used by a JADS representative to talk to other sites. In addition, other operators at each site were provided with the ability to listen in for commands to start and stop equipment under their control.

As with the SIT LSP and LFP, the EW test maintained the conference call throughout the duration of test events. Procedures had to be developed for bringing the conference call up. The test director initiated all calls. In the case of problems, all participants were required to hang up and wait for the test director to initiate a new call add sites to the conference.

In addition to the conferencing and dedicated voice requirements, back-up point-to-point communications were required on all three test programs. A means of contacting specific individuals needs to be defined ahead of time and the information well disseminated. JADS would prepare telephone rosters before each event and give them to all personnel before they departed for the field.

3.1.1.3 Other Considerations

More robust systems can be designed but at significant additional cost. JADS early design efforts focused on expensive systems. Since no one had experience in distributed test and evaluation (T&E), the requirements were unknown during the early test design phases. Therefore, it was determined that it would be unwise to design a costly system that may not satisfy the requirements. The approaches finally used during the JADS tests were adequate and inexpensive relying on existing capabilities whenever feasible.

3.1.2 Audio Speakers

To assist the information flow within the TCAC, several test teams used an audio speaker connected to the main test control network. This circuit was used by data loggers, analysis and the test controller to track the approach of the next run or the end of the current run. The test controller had the capability to turn this speaker off if needed.

3.1.3 Headsets

Special headsets were not required for the TCAC and remote data logger operators. Standard commercial headsets that connect to standard telephones were used at all sites.

3.1.4 Voice Recording Capability

Standard VHS video tapes were used to record voice from the telephone systems. Standard telephones were rewired to provide input to the video cassette recorder (VCR). Two VCRs allowed two phone nets to be recorded for the SIT LSP and LFP. The VCRs were connected to the Barco video switches allowing video displays to be recorded in addition to the voice communications.

3.1.5 Security

As with data networks, voice considerations are a critical issue that must be addressed early in the design process. The requirement to pass classified information on the voice networks will drive the hardware implementation of the voice network.

Security issues were a major concern for the SIT LFP. Unclassified phones were not allowed in many of the areas where personnel needed to be located during the test. Classified phone systems

could not meet the requirements of the test team. The SIT LFP facilities did allow us to use handsets with long cords to extend voice capability into areas where phones were not ordinarily placed. Other work arounds such as using messengers were also used.

The ETE and EW tests had the requirement to pass classified information over the voice network. A solution using STU IIIs would not satisfy the conference call requirement. A small portion of the T-1 bandwidth was used for two voice channels. Since the entire T-1 circuit was encrypted, the classification requirement was satisfied.

3.2 Display Systems

The virtual environment is often different from the one seen by individual nodes. This is because of the translations from the live, virtual, or constructive node in isolation to the virtual environment required to connect them. The successful use of distributed testing requires a means to view this virtual world. JADS has used several viewers, both 2D and 3D.

The value of viewers is dependent upon the task. For integration testing of the system, both 2D and 3D tools are used. The 2D viewers can show the relative positions of the entities in a "God's Eye" view. Problems such as errors in coordinate conversions are usually easy to spot with 2D viewers. 3-D viewers will show anomalies such as missiles coming off of the rails backwards.

A 3D stealth viewer allows the operator to move freely within the virtual environment without creating Protocol Data Units (PDUs) or interacting with other entities. Viewers without the stealth capabilities rely on attaching to different entities to see different portions of the environment.

3.2.1 2D & 3D Displays

The JADS JTF used several different 2 dimensional (2D) and 3 dimensional (3D) tools to display information used for test control.

3.2.1.1 PC Planner Real-time (PLANRT)

PLANRT was developed by NAWCWPNS, at Pt. Mugu, CA. This viewer is a simple 2D viewer but was the most effective viewer for conducting the Systems Integration Test LSP and LFP tests. The viewer provided a simple 2D "God's Eye" representation of the entities. Tracks were drawn to show the entities' paths over time. This was useful in determining if the entities were following the planned scenario(s). During the LFP we found having a common view of the virtual world was extremely beneficial. The translation from real hardware to the virtual world can introduce errors that may be visible on one viewer but not on other displays. A computer with PLANRT installed was shipped

to Eglin AFB, FL for use in integration and development as well as for test control purposes during the LFP tests. This allowed all participants to see the same picture of the scenario and be able to discuss the situation within a common framework.

At the request of JADS, NAWCWPNS added a screen to display target and shooter aircraft flight parameters transmitted in data PDUs. Information included speed, heading, altitude, g-forces, range to target, and closing speed. This capability was used only during the SIT LSP to display "shot box" parameters.

3.2.1.2 Janus Planview

Janus Planview is a 2D viewer developed by TRAC WSMR. The software was designed for 1200 entities and was not able to adequately support 10,000 entities. The implementation resulted in poor refresh rates for the large number of entities. Heterogeneous aggregation or a differing means of screen updates are possible solutions.

In the ETE test, the heartbeat was turned off in Janus after the first 15 minutes. This resulted in large intervals between updates for moving entities. By the time an update was received, an entity might be several kilometers away from where it was located on the previous update. Since Planview does not implement dead reckoning, the entity locations of moving entities were often incorrectly displayed. This made it very hard to follow moving entities but locating stationary entities was very easy.

Planview was very effective in providing a big picture view of the battlefield. During testing, it was used to verify that PDUs were being sent and that they were in approximately the right place. . The combination of a theater level battlefield, ground vehicles, and relatively long heartbeat rates did not provide a lot of movement for observers. During testing, since the HP735 was utilizing all its processing power to update positions it was virtually impossible to interact with. A simple movement of the mouse could take literally minutes to complete. Therefore, the ability to zoom in on specific areas of the battlefield or on specific vehicles was almost impossible.

Since the only platform it was tested with was the HP 735, there is no evidence of how it would perform on a faster platform. The new series of HP machines might be able to provide all the needed processing power to keep up with the frequent display updates.

3.2.1.3 Live Entity Viewer

The Live Entity Viewer (LEVR), from TASC is a 3D stealth viewer with high quality graphic object models and terrain representation. It is intended for aircraft and missile distributed simulations. The version used by JADS required a SGI Reality Engine system and a license for the Paradigm Vega software. TASC's Live Entity Broker (LEB) was used to convert live and recorded Range Applications Joint Program Office (RAJPO) pod data to DIS PDUs which were received in the TCAC and displayed using LEVR.

LEB/LEVR was used extensively in our first connectivity experiment where JADS connected to Eglin AFB prior to the SIT LSP.

3.2.1.4 Mäk Technologies Stealth Viewer

Mäk Technologies Stealth Viewer is a 3D viewer that was used by JADS for the SIT LSP and LFP. The viewer is based upon Mäk Technologies VR-LINK product. This 3D viewer allows people to see objects in the virtual environment in an easy to understand manner. Using this tool, it is easy to determine if the behavior of entities is adequate. For example, this tool allowed interface developers to determine that a simulator to DIS conversion caused the target aircraft to fly upside down. It is easier to operate than LEVR but lacked the high resolution terrain.

The usefulness of 3D viewer was limited to early integration and development tasks for reasons already stated. Therefore, this viewer was not used during test events.

3.2.1.5 Automated Data Reduction System (ADRS)

ADRS was developed by the Georgia Technical Research Institute for displaying and reducing EW test data. The visual capabilities include: a 2D display showing aircraft and threat missile position information, a heads-up display for the aircraft (speed, altitude, and attitude), a radar warning receiver display, and a real-time display of threat emitter and jammer status. The threat emitter and jammer status display was the most beneficial since it made it very clear as to the interactions and timing between the threats and the jammer. For JADS, ADRS was run on a 450 Mhz PC. For performance reasons, two computers were required for test control. One was used to start and stop the test and for the 2D display. The second computer displayed the emitter and jammer status. For redundancy, a third computer was used during phase 2 testing because crashes were frequent.

3.2.2 Large Screen Displays

JADS decided that having information readily available to all personnel in the control center could be beneficial. This would also allow visitors to see what was going on without disrupting test activities. Barco RetroGraphics displays were chosen because they could operate in ambient lighting. They are rear screen projection devices. Three Barco's were purchased and connected to red, green, and blue (RGB) video switches. Computers within the TCAC were then connected to the video switches. Any connected computer could be displayed on any of the three Barcos. The displays could easily be switched between computers with remote controls.

These displays were most useful during the SIT phases. The flight path information was useful and allowed all personnel to have a feel for the ongoing test. Since the SIT LSP runs were of short duration (approximately 2 minutes), fast turn arounds of equipment were required. All the TCAC personnel were able to track a run's progress, giving them a heads-up about upcoming

events (e.g., the end of the run) that they needed to act upon. The 2D track information, the aircraft parameters, and the network tools were displayed on the Barcos for the SIT LSP. The LFP projected the 2D display, network tools, and PDU information from the STRICOM logger display on the barcos.

The display system was the least useful during the ETE test. The long duration, slow pace, and large number of entities of the test made the need to display detailed test monitoring tools unnecessary and impractical. The displays were best used to give an easy view of the test status so large problems would be easily noticed. PDU information (total received, rate, and number of entities), Janus PlanView, and Cabletron Spectrum (an SMNP tool) were displayed on the barcos for the ETE test.

The EW test used the displays to provide similar types of information displayed during the SIT phases. A 2D display of the aircraft and missiles were projected on the barcos. Additionally, threat and jammer states were displayed.

3.3 Video Teleconferencing

Video teleconferencing (VTC) was originally determined to be a JADS requirement based upon the work that was currently being done with the DIS community. The training community were the primary users of this technology at the time initial requirements were being formulated. Originally, JADS foresaw benefits from VTC in the areas of pre- and post-briefs. As each test team developed detailed requirements it was determined that test control requirements were better satisfied by the use of voice circuits over the use of VTC. the use of VTC during test execution was not desired..

JADS saw several problems with the use of VTC. The quality of images was poor and most desktop systems were designed for single users. Larger systems designed for groups were costly and required dedicated circuits and often special circuits such as ISDN. ISDN was not available to the JADS facility from the local telecommunications company. Also, bandwidth consumption was high and the impact on data transmission appeared to be significant based upon theoretical calculations and lessons learned from other efforts.

The initial desktop VTC capabilities that were a part of the initial SGI systems purchased were deemed insufficient for the pre-brief requirements since single use systems cannot be adequately used for larger groups. They had some utility in initial network testing and troubleshooting. Larger VTC systems were not purchase due to high cost, linking requirements, and a changing view of the utility of such tools. Telephone conference calls appeared adequate for the pre-brief and after action review requirements. Existing VTC centers at Kirtland AFB, Pt. Mugu NAS, and China Lake NAS were used during the SIT LSP for planning and reviews.

3.4 Test Control and Analysis Center

The Test Control and Analysis Center (TCAC) was designed as a central control facility. The TCAC was used to control most of the distributed tests. Analysis of test data was the second

major function of the TCAC. Scenario and terrain development tasks for the ETE test were also accomplished within the TCAC. The TCAC was designed for functionality for the test director and computer operators rather than for visitors to view the ongoing tests. Although each test established a different configuration, the basic design was a U-shape oriented towards the large screen displays with the test director in the center. Figure 6 shows the TCAC layout for the ETE phase 4 and the EW phase 2 and 3 tests. The layouts for earlier tests were similar.

The computer equipment was positioned to facilitate communications between individual operators, the test director, and each other. The primary goal was to ensure that the test director could easily talk to anyone in the room.

The analysis areas were separated physically from the test control functions. This allowed analysts from one test team to work while other tests were being conducted. The network was also segmented to prevent traffic from analysis or other activities to impact an ongoing tests. The ETE test, EW test, analysts, and networking functions were all located on separate Ethernet segments. A Cisco 7000 router was used to bridge the four different Ethernet segments. The Cisco 7000 router was chosen for use as a bridge because it was surplus equipment. Ordinarily, less expensive equipment would be used for this task. This configuration is shown in Figure 7.

Test Control and Analysis Center

ETE Phase 4 and EW Phases 2 & 3

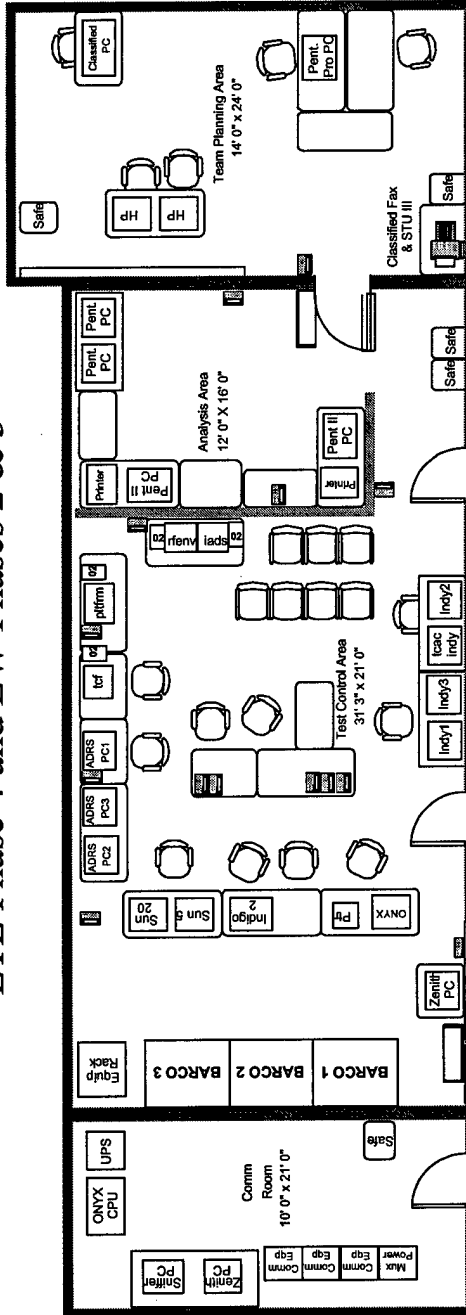

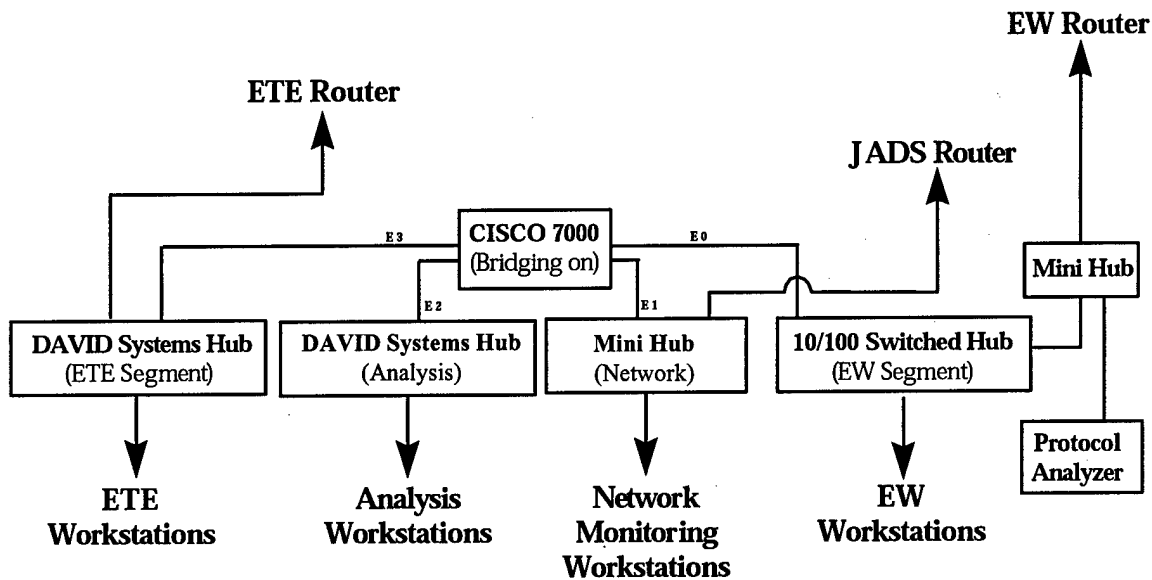

Figure 7 TCAC Network Segmentation

4.0 Test Control Tools

The ability to diagnose problems during a distributed test is critical. A test controller needs the capability to quickly assess failures to avoid wasting critical test resources. JADS used some specialized tools to help monitor different aspects of the test such as the PDU flow and network performance information. This information proved to be useful in finding problems with the network or individual systems at the remote nodes.

4.1 SGI *NetVisualizer*

SGI's *NetVisualizer* is a suite of tools used for network analysis. The tools capture and examine network traffic. These tools are used during network setup to ensure that the network equipment are configured properly, the nodes are talking to each other as intended, and that extraneous network traffic is identified and minimized when possible. During test execution, the tools were used as needed to monitor and trouble shoot the network.

NetVisualizer used centralized Display Stations and remote Data Stations. DIS loggers at each remote site were also used as Data Stations to collect network data. The data from each Data Station was sent to a Display Station located in the Test Control and Analysis Center (TCAC) where the information can be processed and/or displayed.

During the SIT LSP, the traffic utilization on local area networks at each site were monitored. This was done since JADS had no experience in the utilization rates for distributed systems. Also, high traffic rates were observed at the F-14 avionics lab in Pt. Mugu. The situation was

monitored and the rates were high but they were stable and did not impact test results. NetGraph was the NetVisualyzer tool used for this purpose.

Provide a discussion of passive or active monitoring for each network tools. Good.

4.2 Cabletron SPECTRUM

SPECTRUM[®] is a network analysis package developed by Cabletron Systems. It provides a near real-time capability for network traffic monitoring, presenting current packet rate and load information, as well as packet error and discard rate information for network equipment. The package also provides an alarm manager with simple diagnostic capability that is valuable in the detection and troubleshooting of network outages. *SPECTRUM*[®] utilizes the Simple Network Management Protocol (SNMP) to periodically query network devices and displays requested information on screen in table and graphical format. The *SPECTRUM*[®] operator can tailor the destination, frequency, and content of the queries to provide the desired level of insight into a particular network portion or piece of equipment. Like *NetVisualyzer*[™], *SPECTRUM*[®] queries for data to create network traffic, although not of appreciable quantity to be noticed in relation to the test traffic. Typically, a five-second polling interval was used to monitor the network equipment, a value chosen so that short duration problem events would most likely not be missed. Multiple databases store *SPECTRUM*[®]'s event log and query results for later analysis.

4.3 AG Group, Inc., EtherPeek[™]

EtherPeek[™] is a network analysis package developed by AG Group Inc. This product is a suite of protocol analysis tools that can be used during network setup or during testing to ensure that network equipment is configured properly, nodes are talking to one another as intended, and to assist the network manager in identifying, eliminating, or minimizing extraneous network traffic. It provides real-time capability for network traffic monitoring, presenting current packet rate and load information, as well as packet error information. Local and remote *EtherPeek*[™] data stations passively collect all LAN traffic at each site for real-time network analysis. Unlike *NetVisualyzer*[™] and *SPECTRUM*[®], *EtherPeek*[™] does not create any additional network traffic. The protocol analysis part of the tool set was extremely valuable to the EW Test in analyzing latency and data dropouts between nodes.

4.4 DIS Loggers

STRICOM distributed a logger in their DIS Test Suite package of software. The logger displayed PDU information in a tabular format. Information such as instantaneous and average PDU rates and the number of PDUs received by type were displayed. While the logger presented some problems recording PDU for analysis the tool was useful for the display. The displayed information gave the test controller another tool to verify that the test was executing as expected. The tool was not used to collect data for analysis since the time stamps were not as accurate as JADS required due to graphic screen updates interfering with the time stamp and recording

processes. Non-graphical loggers were developed by JADS to record this data for latency analysis.

4.5 JADS RTI Interface Logger

This logger used for the EW test resided in the software interface between the federate and the RTI. It recorded all function calls to and from the RTI along with all the function data parameters. For example, when the federate wanted to publish data, it called the RTI `updateAttributeValues` function. When the logger was linked with the federate, the federate called the logger `updateAttributeValues` function. The logger stored the function identification and parameter data in the log file buffer and then called the RTI `updateAttributeValues` function. When a log file buffer became full, it was written asynchronously to the log file and a new buffer was created.

The logger was designed to minimize impact on the federate with which it was linked. To accomplish this, the logger design included the following features: asynchronous direct I/O, nondegrading process priority, and binary file format.

Asynchronous I/O was used so that the federate software did not wait while the data were written to the log file. When a buffer became full, an I/O request was queued to the operating system and control was immediately returned to the federate. A separate process accomplished the actual writing of the data.

Direct I/O allowed the operating system to use the data buffer created by the logger software to write the data to the disk. Normally, the operating system copied the data from the user buffer to a system buffer. However, use of direct I/O eliminated this copy operation.

If a user with super-user privileges executed the logger within the federate, the logger would take advantage of system nondegrading priorities to further minimize the impact of the logger I/O on the federate. When asynchronous I/O was initialized, a set of processes was created to perform the writing of the data to disk. When these processes were created, they inherited the priority of the process that created them. The logger software lowered the priority of the process before the asynchronous I/O was initialized. After the I/O processes were created, the logger software set the federate process priority to a real-time priority. Since the I/O processes executed a lower priority than the federate process, the I/O processes never interfered with the federate process.

The log file created by this software was a binary file. Attribute and interaction data were received by the logger (or by the federate) in a binary format. In the interest of minimizing the processing time used by the logger, the binary data received from or sent to the RTI were written directly to the log file without any conversion.

Since the logger software writes all the binary data sent to or received from the RTI without attempting to translate or convert them, the logger can be linked with any federation without

modifications to the logger software. Also, since the logger classes were derived from the RTI base classes, very few lines of code must be changed to incorporate the logger into an existing federate. Less than twenty lines of code were modified or added to link the logger with the helloWorld demo program provided with the RTI.

4.6 HLA Link Health Check

A combination of in-house tools and commercially developed software products provided JADS with a real-time, or near real-time, limited capability to assess network performance and evaluate the integrity of data as they were being collected during Phase 3 testing. The various tools were used to help provide a clear picture of the network and to speed diagnostic and maintenance efforts during a test. Simple Network Management Protocol (SNMP) tools were used to monitor communications and network hardware. This allowed JADS personnel to see, in near real time, the status of the long-haul links as well as the routers connecting remote sites. The SNMP tools also allowed JADS to monitor and record the bandwidth used on the T-1 links.

Each federate sent link health check updates and displayed the information received from other federates. This was used during testing not only to determine the health of the each federate but as another view of the overall health of the network. In addition, a simple UNIX utility used standard pings to display the status of various federation computers. This tool often presented the test team and networking personnel with the first indication that a problem existed with the network and/or the computers at each site.

The JADS EW test required all federates to publish a link health check message once per second. The federates developed by Georgia Tech Research Institute included displays of information from the link health check messages received from each of the federations. This information displayed in the TCAC, was used by the test controller to help control the sequence and timing of the federation startup for each run. As each run executed, the displays also alerted the test controller and federate operators to problems with specific federates. If messages from a federate were no longer being received this was displayed. It could then be determined, usually by voice, whether the federate had crashed or another problem (such as with the network) had to be investigated.

4.7 Time Synchronization

JADS used both software and hardware methods to synchronize the computers across the distributed test network. The software solution was required because the SGI workstations had proprietary bus architectures and time cards were not available for that bus early in the program. A Global Positioning System (GPS) receiver was used to provide Inter-range Instrumentation Group (IRIG-B) time signals to a single SGI via serial cable. The SGI became a stratum one time server and a network time protocol application, XNTP, from the University of Delaware was used to distribute time to all of the SGI and Sun workstations throughout the network. One step in the

network startup procedures before tests required that the time synchronization be tested. The XNTP software has built in tools that allow comparisons between the time on two machines. This allowed the time on each remote workstation to be compared with the stratum one server to determine accuracy.

The hardware solution was used for the EW test. By the time we began to select and integrate hardware for the EW test, time cards for the SGI and Windows NT computers were available. Each computer had a Bancomm time card from Datum. Each of the three sites were equipped with GPS receivers which became IRIG-B time sources for the cards.

The ability to compare and synchronize time between the facilities was not available with the hardware. Time synchronization was performed by initiating a normal run and after a jamming response was observed in the TCAC the execution was stopped. The recorded times for all messages in federate log files were then compared. If they were "reasonable" (within +/- 20 milliseconds of each other), the facilities were considered to be in synchronization. The inability to confirm synchronization and monitor it throughout the test might be considered a limitation of the hardware solution. Regardless of the trust we place in GPS as a time source, the JADS test data did identify at least one instance where a facility's timing drifted out of synchronization.

4.8 JADS Toolbox

JADS discovered early on that the test controller and analysts needed displays for troubleshooting, analysis, and visualization. To meet these needs, JADS developed a software product for JADS called the JADS Analysis Toolbox. It comprised a set of analysis tools integrated into a single user interface. It allowed users to view protocol data unit (PDU) data in near real time, replay PDUs from a log file, post-test, and obtain various PDU data/statistics, post-test. The toolbox was used for quick-look analysis and monitoring of test data throughout the tests.

The JADS Analysis Toolbox, developed for the SIT, worked very well for the SIT. However, without modifications, it was inadequate for the ETE test. Long delays were introduced because of the large size of the ETE test log files. In addition, the number and method of creating entities for the ETE test were significantly different from the method used for the SIT. This required changes in the way analysis routines handled data from the ETE test files.

5.0 Test Control Lessons Learned

These lessons learned incorporate findings from interim and final reports for SIT, ETE, and EW test efforts.

5.1 Planning-

- The test control requirements for an ADS test must be clearly defined early in the test planning phase.
 - Detailed planning and coordination are required to ensure a common understanding of all requirements, procedures, and test objectives. Individual facilities are not generally familiar with conducting coordinated, distributed T&E tests and this common understanding is critical. Test control must be an early part of the planning process to avoid last minute control issues between different nodes.
- Piggybacking off of other activities is not always practical. Some attempts were made to accomplish SIT LFP objectives by leveraging off of other activities at Eglin, but these piggyback attempts resulted in significant delays and problems satisfying SIT LFP requirements. These attempts were unsuccessful because of conflicts in test control of the piggyback flight assets and support equipment.
- Configuration control is essential. Configuration control of the network and the ADS/DIS system, including its hardware, software, and its simulator interfaces, is necessary starting at the beginning of the program.. It is particularly important during test events that the test controller is aware of configuration changes and that they are approved prior to changes.
- Pilots should be involved in scenario setup. It was very beneficial to contact the test squadron pilots in order to achieve the correct flight profiles and launch parameters. The LFP missions were based on previously flown AMRAAM profiles, and the goal was to replicate those profiles (within LFP limitations). It was difficult to match the scenario launch conditions during high-g maneuvers. The best results came when the project personnel met with the pilots to review possible setup options, then reviewed the flight plan during the pilots' pre-mission briefing.
- Live missions require more test control contingency planning. Live aircraft operations required more contingency planning to quickly decide on alternatives. A great benefit for using an ADS-linked network was having several "analysts-in-the-loop" during the real-time mission. The JADS test director had to make timely decisions between the aircraft passes in order to affect the outcome or productivity of the mission. Initially, a small list of go/no go criteria was made before the first live flight. This list included criteria on key aircraft components, and on aircraft pods or ground systems. As the experience level increased after risk reduction missions, this list was expanded to include alternatives in case of failures or degraded assets. Having this contingency plan spelled out in advance truly helped the test director make rapid, well-informed decisions to get the most productive use out of the remaining mission time.
- Use risk reduction tests for integration and test control procedures The series of risk reduction tests was extremely useful to progress through many levels of integration work. The Eglin members designed a building block approach to check out interfaces at the

lowest level, as well as developing test control procedures. The risk reduction efforts allowed test procedures to be refined prior to actual test events.

- High personnel turnover hurts test control development. Not surprisingly, high turnover made the development of procedures and training of test participants difficult. Some of the JADS test efforts were conducted over lengthy time spans. From one test phase to the next changes in operators made the use of rehearsals even more critical to successful testing. All three of the JADS test experienced the loss of key personnel over the test life spans. The distributed nature of the effort did not allow for tight personnel controls possible at a single site.

5.2 Security

- Network security is an essential part of operating an ADS network. The network accreditation process needs to be addressed and started in the planning phase. Security and accreditation procedures are different for every site and branch of service. Hence, it becomes inherently difficult to execute inter-agency memorandums of agreement (MOA). Security focal points and designated approval authorities need to be identified early in the planning process and close coordination with these individuals is essential to executing network installation and meeting test schedules. It is wise to factor approximately three months into the implementation schedule to execute the required security MOAs.
- OPSEC requirements for a distributed weapon system test must be determined and coordinated early in the program, especially with the various organizations and their different procedures. Issues to be addressed include: the need for an OPSEC Plan; if an OPSEC Plan is required, an agreement either to use an already approved OPSEC Plan or to draft a new OPSEC Plan; the consistency of OPSEC requirements among the various organizations and programs; OPSEC requirements in test control/conduct, including the use of "For Official Use Only" test cards and step calls and/or the use of secure communications.

5.3 Network Instrumentation Tools

- Time sources must be synchronized. IRIG/GPS time must be synchronized off of the same time source and then must be validated at each test site prior to project operations to ensure accurate, synchronized time is precisely recorded at each test site. A test controller needs this common time reference to control and trouble shoot problems which occur during test events. The level of accuracy will vary depending on the test but easily could vary from one millisecond to several seconds.

- Special test equipment is needed for checkout and verification. Special test equipment (e.g., SNAP loggers, DIS data loggers, etc.) and other networking tools (e.g., Stealth Observer) should be part of each simulation node's configuration during the development, test, checkout, and verification/validation phases in all subsequent ADS testing. Special test equipment and networking tools are required to more rapidly isolate and determine the specific cause of network, ADS/DIS, etc. problems. This capability is a key part of effective test control. If problems can not be diagnosed quickly a test controller may waste the availability of critical test assets.

5.4 Command and Control

- Have a centralized test control center. Test controllers should be extremely familiar with the test and network configuration. The JADS TCAC was configured to allow for convenient, instant communications with all the nodes. It acted as the central point of contact between the nodes and for all problems. The test controller kept track of test progress, documented any problems that occurred and kept the test director informed.
- Project and scenario control were best performed at the test range. Another issue was where to locate project decision makers to control the scenarios and test events. During early risk reduction tests, it became apparent that when handling developmental problems, there was significant discussion that was never transmitted via radio links. Much troubleshooting was still communicated face-to-face, over local intercom, or via direct phone line. Even with some display monitors, personnel at remote sites would often hear about problems late, often with only partial explanations. Therefore, in order to be part of the decision making process, the JADS test director had to be collocated with the CCF coordinator and the range aircraft controller. The CCF was the necessary choice, since it was centrally located with the critical personnel, the majority of system displays, all communication networks including a direct link to the test controller in the TCAC.
- Distributed tests require personnel distribution. When many distributed nodes are required for the successful completion of a test, personnel will need to be located at these nodes. The complexity and input an individual node contributes should guide the assignment of personnel.
- A T-24 hours pre-mission briefing is needed before each mission. A pre-mission briefing was held 24 hours before each mission and was critical for coordinating the many network and flight test issues. The briefing agenda by the test director should include the test objectives, planned run matrix, personnel involved, communication plan with back-up phone numbers, show time for personnel, go/no go criteria, contingency plans in case of failures, instrumentation and data collection requirements, and details on facility configuration.
- Day of test briefings are needed before and after each mission. Briefs and debriefs should be conducted before and after each mission. The briefs should cover such items as the test

objectives, telephone numbers/frequencies to use for test control, test configuration of each facility, instrumentation and data collection requirements, go/no go criteria, contingency/back-up plans, test conduct including a detailed review of test cards, communications procedures, OPSEC, and the time and place of the debrief. A briefing checklist should be developed and used by the test director.

- Adequate time must be allotted for data analysis between test events. There was a tendency to underestimate the time required to adequately analyze the large volume of data collected in the test events. As a result, some problems from one mission were not fully diagnosed and fixed before the next mission. In fact, some problems (e.g., target initialization errors) were not even recognized until all test was over. Rehearsal of the analysis procedures should be used to better estimate the time required for adequate analysis between test events.

- Tight control of the aircrew is not desirable. The aircrew should be allowed to perform as aircrew during man-in-the-loop testing. Too much test control (e.g., "fire" instead of "cleared to fire") is not desirable with the man-in-the-loop, particularly if it is OT&E or combined DT&E/OT&E. Testing is more valuable and there are more "lessons learned" from a test where the aircrew are given the critical parameters and switchology to meet the test objective(s) and are still allowed to make tactical decisions, fly the "aircraft," operate the weapon system, etc. A tightly controlled test is appropriate for certain testing such as computer simulations and stand-alone laboratory tests.

- Additional time is needed before the beginning and after the end of each testing period. Allocate a minimum of an additional two hours of time at the end of each test period for data logging, data archiving, data transfer, and laboratory reclassification. Allocate a minimum of an additional one hour of set-up time prior to each test period. The pre- and post-test requirements should be included in the number of hours needed for each test period and incorporated into the planned costs. This additional time must be coordinated between all nodes by the test controller.

- Test control procedures should be well rehearsed. Communication and coordination among ADS test team members are vital for the success of an ADS test especially when changes or additions are made to the test environment. When many people are communicating on one phone line, a response order should be established and strictly followed to save valuable test time.

- Two-dimensional displays were needed at each node. Using a graphical 2-D display greatly improved the situational awareness of participants at each testing site. The 2-D display converted the ES PDUs into symbols overlaid on a local area map. As a result, the team members knew where and in what direction the aircraft were flying and if the missile simulation was active.

- Existing range procedures had to be modified for ADS. The existing Eglin test procedures were only written for individual facilities, so a new combined checklist was created for ADS applications. The AFDTTC Program Manager developed a new checklist which interleaved some actions from each facility in order to get proper connectivity between the CCF, MISILAB, and PRIMES. This checklist covered activities from 24 hours prior, 4 hours prior, 1 hour prior, and, of course, during the mission time.
- Lab replays served as an excellent method of rehearsal. By replaying a set of prerecorded data, all the Eglin team members could participate in a laboratory replay session. This was an excellent method to rehearse test procedures, work out technical and procedural issues, and troubleshoot problems in a low-cost, low-stress lab session.

5.5 Communications

- Test Control communications requirements must be addressed early in the test planning phase.
This is necessary to ensure effective communications during the test. Remote test control for SIT test used two non-secure telephone conference bridges (i.e., two communications nets) which were acceptable. However, the audio level between connections varied, making "loud and clear" communications among all the sites difficult at times. ETE and EW testers also used dedicated voice circuits on segmented portions of the network T-1 lines. If T-1 lines are to be used for test control then planning should include the 120 days lead time needed to install them.
- A standard, linked test should have multiple (more than two) communications nets (e.g., control, analyst, network, and internal laboratory) with easy, selectable access to all the nets from multiple locations within the laboratory. A minimum of one secure telephone at each site is also required. More complex, linked tests may require additional non-secure and/or secure communications nets. Speakers with plug-in push-to-talk handsets and/or headsets with push-to-talk switches are required at strategic locations throughout the laboratory to allow individuals the necessary mobility and communications flexibility. Speakers are also necessary when VIP visitors or other personnel monitor the test at the laboratory.
- The capability for secure video teleconferences (VTCs) among multiple (more than two) sites is helpful for pre and post test mission briefs. Additionally, secure telephone conference bridges are also required when a test must be conducted using secure communications (e.g., a special project test), or when a secure VTC is not available and secure briefs/debriefs are necessary.
- Thoroughly test the voice communication systems followed by a rehearsal with all sites and the actual players before any test event. It is critical that the personnel involved in a test participate in any rehearsals so that they fully understand the processes and procedures, including contingency plans. Backup means of communication are critical. Point-to-point telephones and beepers were the primary backup methods used by JADS. At times, even faxes, computer talk sessions, and e-mail were used.

- Security issues can affect how voice communications are implemented in individual facilities. Facility security policies often determine where phones may or may not be placed. The restrictions may be based on keeping phones away from electronic emanations from classified systems or so that classified conversations may not be inadvertently passed across an unclassified phone system. Each facility and each test program has to be handled differently; the important thing to remember is to determine the restrictions early enough for work-arounds to be determined and implemented.

6.0 References

1. Systems Integration Test, Linked Simulators Phase, Final Report, Joint Advanced Distributed Simulation Joint Test and Evaluation, Albuquerque, New Mexico, July 1997
2. Systems Integration Test, Live Fly Phase, Final Report, Joint Advanced Distributed Simulation Joint Test and Evaluation, Albuquerque, New Mexico, March 1998
3. End-to-End Test Interim Report Phase 4, Joint Advanced Distributed Simulation Joint Test and Evaluation, Albuquerque, New Mexico, August 1999
4. Electronic Warfare Test Interim Report Phase 3, Joint Advanced Distributed Simulation Joint Test and Evaluation, Albuquerque, New Mexico, November 1999.
5. JADS Special Report on Networking and Engineering, Joint Advanced Distributed Simulation Joint Test and Evaluation, Albuquerque, New Mexico, August 1999.

A/C
A²ATD
AASI

aircraft
Anti-Armor Advanced Technology Demonstration
Advanced Aircraft Simulation Interface

ACE	analysis and control element
ACETEF	Air Combat Environment Test and Evaluation Facility, Patuxent River, Maryland; Navy facility
ADEWS	Advanced Distributed Electronic Warfare System; Army sponsored
ADS	advanced distributed simulation
ADT	air data terminal
AFATDS	Advanced Field Artillery Tactical Data System
AFB	Air Force Base
AFEWES	Air Force Electronic Warfare Evaluation Simulator, Fort Worth, Texas; Air Force managed with Lockheed Martin Corporation
AIM	air intercept missile
ALQ-131	a mature self-protection jammer system; an electronic countermeasures system with reprogrammable processor developed by Georgia Tech Research Institute
AMRAAM	advanced medium range air-to-air missile
API	application program interface
ARIES	Advanced Radar Imaging Emulation System
ASAS	All Source Analysis System
ATACMS	Army Tactical Missile System
AVTB	Aviation Test Bed at Fort Rucker, Alabama
BMIC	Battle Management Interoperability Center at Naval Air Warfare Center, Point Mugu, California
C4I	command, control, communications, computers and intelligence
C4ISR	command, control, communications, computers, intelligence, surveillance and reconnaissance
CCF	Central Control Facility, Eglin Air Force Base, Florida
CGS	common ground station
CONOPS	concept of operations
CROSSBOW	Office of the Secretary of Defense committee under the director, Test, Systems Engineering and Evaluation
CSU	channel service unit
DIS	distributed interactive simulation
DMAP	data management and analysis plan
DMSO	Defense Modeling and Simulation Organization, Alexandria, Virginia
DoD	Department of Defense
DSI	Defense Simulation Network
DSM	digital system model
DSU	data service unit
DT&E	developmental test and evaluation
ECM	electronic countermeasures
EPF	engineering protofederation
ES	electronic support
ESPDU	entity state protocol data unit
ETE	JADS End-to-End Test
EW	electronic warfare; JADS Electronic Warfare Test

FAT	federate acceptance test
FBCB ²	Force XXI Battle Command, Brigade and Below
FED	federation
FEDEP	federation development and execution process
FEDEX	federation executive
FIT	federate integration test
FOM	federation object model
FOT&E	follow-on operational test and evaluation
FTP	file transfer protocol
FY	fiscal year
GB	gigabyte
GDT	ground data terminal
GPS	global positioning system
HITL	hardware-in-the-loop (electronic warfare references)
HLA	high level architecture
HW	hardware
HWIL	hardware-in-the-loop (system integration references)
IADS	Integrated Air Defense System
ICD	interface control document
ID	infantry division; identification
IDNX TM	Integrated Digital Network Exchange
IEEE	Institute of Electrical and Electronics Engineers
IGMP	Internet Group Management Protocol
INS	inertial navigation system
IP	Internet protocol
IPPD	integrated product and process development
IPT	integrated product team
IR	infrared
IRIX	operation system for the Silicon Graphics, Inc.
ISTF	installed systems test facility
IRIG	Inter-Range Instrumentation Group
J/S	jamming-to-signal ratio
JADS	Joint Advanced Distributed Simulation, Albuquerque, New Mexico
Janus	interactive, computer-based simulation of combat operations
JCSAR	Joint Combat Search and Rescue
JECSIM	Joint Electronic Combat Testing Using Digital Simulations
JETS	JammEr Techniques Simulator
JSF	Joint Strike Fighter
Joint STARS	Joint Surveillance Target Attack Radar System
JT&E	joint test and evaluation
JTF	joint test force
JTMD	Joint Theater Missile Defense
LAN	local area network
LFP	Live Fly Phase
LGSM	light ground station module

LHC	link health check
LRC	local runtime infrastructure component
LSP	Linked Simulators Phase
M&S	modeling and simulation
Mbps	megabits per second
MCTS	Mission Crew Training System
MISILAB	Missile Simulation Laboratory, Eglin Air Force Base, Florida
MITRE	company that provided engineering services
MOE	measure of effectiveness
MOP	measure of performance
MOT&E	multiservice operational test and evaluation
MSL	missile
NATO	North Atlantic Treaty Organization
NETVisualizer™	software that displays real-time bandwidth use in a rolling bar graph format for quick visual reference
NIU	network interface unit
NTP	network time protocol
OAR	open air range
OPTEMPO	operations tempo
OSD	Office of the Secretary of Defense
OT	operational test
OT&E	operational test and evaluation
OTA	Office of Technology Assessment
PC	personal computer
PDU	protocol data unit
PGM	precision guided munitions
PIM-DM	protocol independent multicast-dense mode
PMO	program management office
P-value	probable value
RDAPAS	Radar Detection and Performance Analysis System
RDL	rear data link
RELDISTR	reliable distribution
RF	radio frequency
RFENV	radio frequency environment
RID	runtime infrastructure initialization data
RM&A	reliability, maintainability and availability
RTI	runtime infrastructure
RTIEXEC	runtime infrastructure executive
SAIC	Science Applications International Corporation
SAR	synthetic aperture radar
SATCOM	satellite communications
SBA	Simulation Based Acquisition
SCDL	surveillance control data link
SE	synthetic environment
SEOT	synthetic environment operational test

SETI-VTP	Synthetic Environment Tactical Integration
VTP	Virtual Torpedo Project
SGI	Silicon Graphics, Inc.
SIL	system integration laboratory
SIM	simulation
SIMLAB	Simulation Laboratory, Naval Air Warfare Center, China Lake, California
SINGARS	Single-Channel Ground and Airborne Radio System
SIT	JADS System Integration Test
SMC	source mode change
SME	subject matter experts
SMS	stores management system
SOW	statement of work
SPECTRUM®	a network analysis package developed by Cabletron Systems
SPJ	self-protection jammer
SRS	software requirements specification
STEP	simulation, test and evaluation process
STORM	Simulation, Testing and Operations Rehearsal Model
STTAR	synthetic test and training architecture
SUT	system under test
SW	software
T&E	test and evaluation
T/E	tracking error
T-1	digital carrier used to transmit a formatted digital signal at 1.544 megabits per second
T-3	298 T-1 lines in one; the aggregate data rate is 44.746 megabits per second
TAC	target analysis cell
TACCSF	Theater Air Command and Control Simulation Facility
TAFSM	Tactical Army Fire Support Model
TAMS	Tactical Air Mission Simulator
TCAC	Test Control and Analysis Center, Albuquerque, New Mexico
TCF	test control federate
TCP	transmission control protocol
TDP	time-space-position information data optimizing processor
TEMP	test and evaluation master plan
TGT	target
TMD	Theater Missile Defense
TRAC	U.S. Army Training and Doctrine Command (TRADOC) Analysis Center
TRADOC	U.S. Army Training and Doctrine Command
TSLA	Threat Simulator Linking Activity
TSPI	time-space-position information
TTH	terminal threat hand-off federate
TTP	tactics, techniques and procedures
UDP	user data protocol
UHF	ultra high frequency
UMB	umbilical

UNIX™	registered trademark of UNIX Systems Laboratories
V&V	verification and validation
VPG	virtual proving ground
VSTARS	Virtual Surveillance Target Attack Radar System
VV&A	verification, validation, and accreditation
WAN	wide area network
WBS	work breakdown structure
WSIC	Weapons System Integration Center, Naval Air Warfare Center, Point Mugu, California
WSMR	White Sands Missile Range, New Mexico
WSSF	Weapon System Support Facility, China Lake, California

1. Systems Integration Test, Linked Simulators Phase, Final Report, Joint Advanced Distributed Simulation Joint Test and Evaluation, Albuquerque, New Mexico, July 1997
2. Systems Integration Test, Live Fly Phase, Final Report, Joint Advanced Distributed Simulation Joint Test and Evaluation, Albuquerque, New Mexico, March 1998
3. End-to-End Test Interim Report Phase 4, Joint Advanced Distributed Simulation Joint Test and Evaluation, Albuquerque, New Mexico, August 1999
4. Electronic Warfare Test Interim Report Phase 3, Joint Advanced Distributed Simulation Joint Test and Evaluation, Albuquerque, New Mexico, November 1999.
5. JADS Special Report on Networking and Engineering, Joint Advanced Distributed Simulation Joint Test and Evaluation, Albuquerque, New Mexico, August 1999.