

**Real –Time/Predictive Medical Data
Fusion Watchboard
Phase I Option Final Report – 0002AB**

February 23, 2000 through May 23, 2000

**Office of Naval Research
Contract Number N00014-99-M-0135
Navy Small Business Innovation Research Program**

ScenPro, Inc.

**101 West Renner Road, Suite 130
Richardson, Texas 75082
972-437-5001**

Approved for public release; SBIR report, distribution unlimited



ScenPro, Inc.

DTIC QUALITY INSPECTED 1

20000530 097

REPORT DOCUMENTATION PAGE

FORM APPROVED
OMB No. 0704-0188

Public reporting burden for this collection of information is estimated to average 1 hour per response, including the time for reviewing instructions, searching existing data sources, gathering and maintaining the data needed, and completing the reviewing the collection of information. Send comments regarding this burden estimate or any other aspect of this collection of information, including suggestions for reducing this burden, to Washington Headquarters Services, Directorate for Information Operations and Reports, 1214 Jefferson Davis Highway, Suite 1204, Arlington, VA 22202-4302, and to the Office of Management and Budget, Paperwork Reduction Project (0704-0188), Washington, DC 20503.

1. AGENCY USE ONLY (Leave blank)	2. REPORT DATE <p style="text-align: center;">23May2000</p>	3. REPORT TYPE AND DATES COVERED <p style="text-align: center;">Final March 2000 – May 2000</p>
----------------------------------	--	--

4. TITLE AND SUBTITLE <p style="text-align: center;">Real-Time Predictive Medical Data Fusion Watchboard Final Technical Report – 0002AB</p>	5. FUNDING NUMBERS <p style="text-align: center;">N00014-99-M-0135</p>
---	---

6. AUTHOR(S) Gately, Michael Terry, Beth	
--	--

7. PERFORMING ORGANIZATION NAMES(S) AND ADDRESS(ES) ScenPro, Inc. 101 West Renner Road, Suite 130 Richardson, TX 75082	8. PERFORMING ORGANIZATION REPORT NUMBER <p style="text-align: center;">ONRB1-PI-FR</p>
---	--

9. SPONSORING/MONITORING AGENCY NAMES(S) AND ADDRESS(ES) Office of Naval Research 800 North Quincy Street, Ballston Tower One Arlington, VA 22217-5660	10. SPONSORING/MONITORING AGENCY REPORT NUMBER <p style="text-align: center;">0002AB</p>
---	---

11. SUPPLEMENTARY NOTES

12A. DISTRIBUTION/AVAILABILITY STATEMENT <p style="text-align: center;">Approved for public release; SBIR report, distribution unlimited</p>	12B. DISTRIBUTION CODE
---	------------------------

13. ABSTRACT (Maximum 200 words) <p><u>Purpose:</u> This report outlines the development of a Real-time/Predictive Medical Data Fusion Watchboard (referred to as "NavMedWatch") to enhance the current Navy medical care system and improve medical readiness. The proposed NavMedWatch provides streamlined data to Navy medical care providers, support personnel and remote command staff allowing for the rapid visualization and assessment of the tactical medical situation. NavMedWatch includes a simulation capability for predicting resource shortfalls, intelligent agents for shortfall resolution, and record/playback capability for training activities and after-action reviews.</p> <p><u>Action:</u> A NavMedWatch prototype was developed to continue work performed in Phase I and to simulate the interface required for TMIP data access.</p> <p><u>Results and Applications:</u> NavMedWatch provides a common data collection and dissemination point for medical personnel at the MTF and JTF levels and has been enthusiastically received by a representative group of potential users.</p>
--

14. SUBJECT TERMS <p style="text-align: center;">medical planning, medical status, real-time, information, watchboard, predictive, data fusion</p>	15. NUMBER OF PAGES <p style="text-align: center;">17</p>
	16. PRICE CODE

17. SECURITY CLASSIFICATION OF REPORT <p style="text-align: center;">unclassified</p>	18. SECURITY CLASSIFICATION OF THIS PAGE <p style="text-align: center;">unclassified</p>	19. SECURITY CLASSIFICATION OF ABSTRACT <p style="text-align: center;">unclassified</p>	20. LIMITATION OF ABSTRACT <p style="text-align: center;">SAR</p>
--	---	--	--

Real-Time/Predictive Medical Data Fusion Watchboard Phase I Option Final Report

ScenPro, Inc. is pleased to provide this Phase I Option Final Report for SBIR Topic number N99-025, "Real-Time/Predictive Medical Data Fusion Watchboard," award contract number N00014-99-M-0135. This document describes the Phase I research and the development of a prototype Real-time/Predictive Medical Data Fusion Watchboard (referred to as NavMedWatch). Specifically, this report outlines the findings of research performed during the Phase I Option period ending May 23, 2000.

NavMedWatch was designed to enhance the current Navy medical care system and improve medical readiness. The watchboard tool described in this report would provide streamlined data to Navy medical care providers, support personnel and remote command staff allowing for the rapid visualization and assessment of the tactical medical situation.

NavMedWatch is designed to gather data from existing sources including TMIP (Theater Medical Information Program), TMCS (Theatre Medical Core Services), FMSS (Field Medical Surveillance System), pre-configured databases, and/or Internet Repositories, as well as from future sources such as personnel status monitors, personnel locators, and Personal Identification Cards. NavMedWatch displays are designed to include graphical, textual, and color coding of relevant data for quick and easy interpretation and analysis.

1.0 System Architecture

As described in the Phase I Final Technical Report (dated October 31, 1999), the proposed watchboard architecture is broken down into two functional areas – the Medical Treatment Facility (MTF) and the Joint Task Force (JTF). The MTF NavMedWatch is designed to be used in a stand-alone fashion, while the JTF NavMedWatch would be used to display summary status information at the theater level. In addition, the JTF NavMedWatch would allow users to access information associated with individual MTFs. Figure 1 illustrates an example communication architecture within a Theater of Operation. Each MTF has one or more NavMedWatch tools connected, via an intranet, to each other as well as to the JTF NavMedWatch.

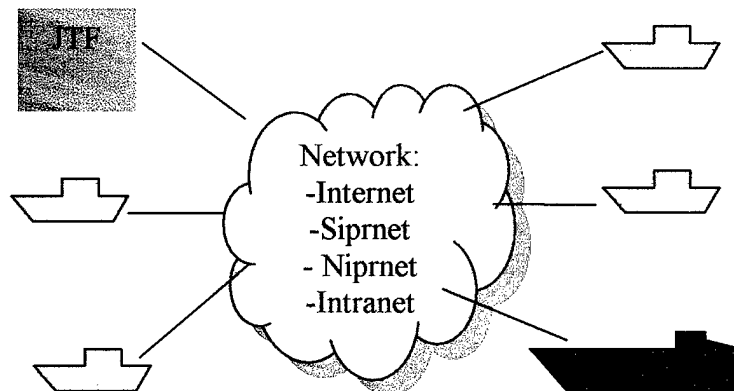

Figure 1. Example Communication Architecture for a Theater of Operation

A more detailed view of the connectivity between the NavMedWatch tools is illustrated in Figure 2. This configuration is the same for both the MTF and JTF environments.

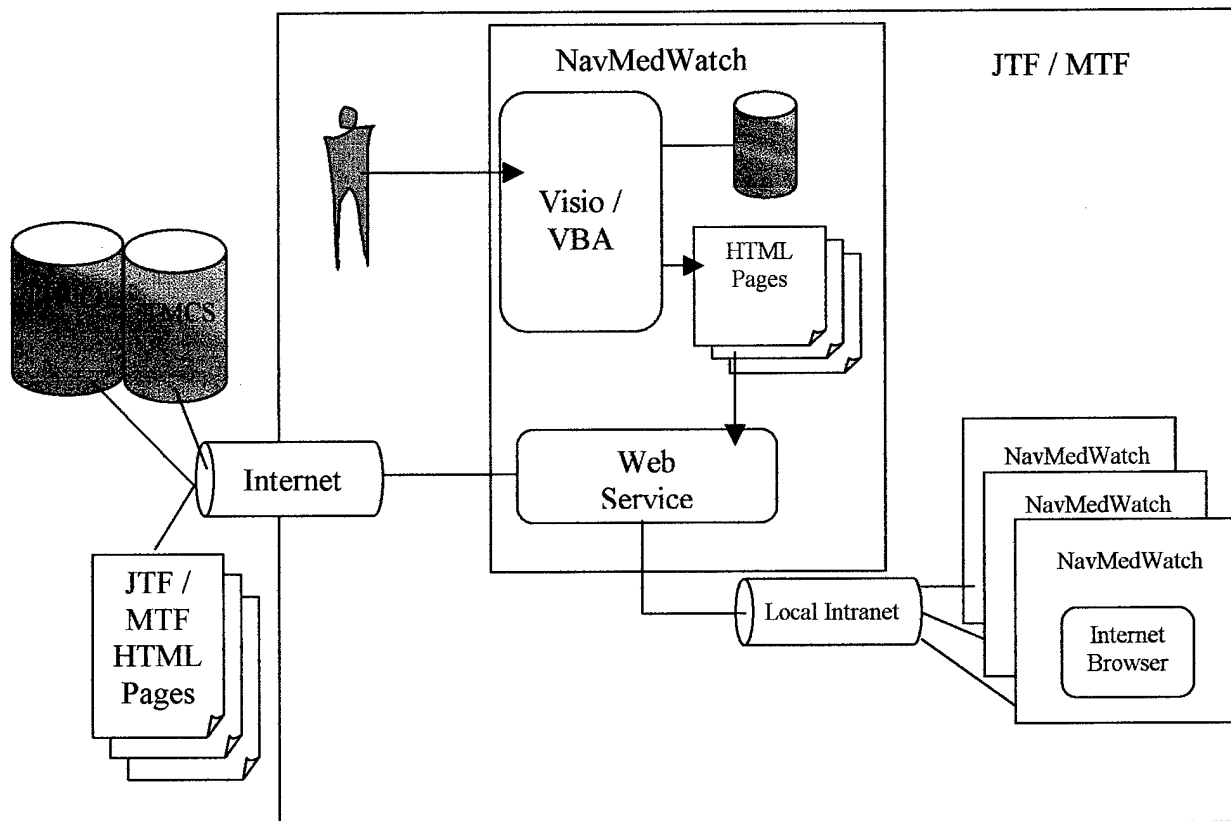

Figure 2. JTF/MTF NavMedWatch Configuration

The data used to populate the NavMedWatch tool can be provided by a variety of data sources. During the Phase I portion of the contract, the TMCS program was studied as a possible data source. During the Phase I Option period, selected sources from the Theater Medical Information Program (TMIP) were studied. Both provide viable sources of example input data. The research conducted on the TMIP database structure is discussed in more detail in the Section 2.0 Research Performed.

The “JTF/MTF HTML pages” box shown in Figure 2 connected to the Internet figure represents the network connection of multiple NavMedWatch tools within the theater. The “Local Intranet” connection illustrates how the multiple NavMedWatch tools can be configured within an MTF or JTF site. One NavMedWatch tool acts as the primary watchboard while the other tools are connected on the intranet and act as remote watchboard sites. The primary NavMedWatch tool would require that Visio™ be installed on the user’s workstation. This tool would then export Visio screens as html pages to a pre-determined universal resource locator (url). The remote users can then access and display the exported NavMedWatch screens via an internet browser (such as Internet Explorer).

1.1 NavMedWatch Components

The NavMedWatch tool architecture (illustrated in Figure 3) is composed of the following 7 components:

- User Interface/Monitor,
- Data Interface,
- System Controller (includes the display functionality),
- Predictive Casualty Management Simulation,
- Intelligent Interviewing Agent,
- Epidemiological Predictions,
- Historical Data and Playback.

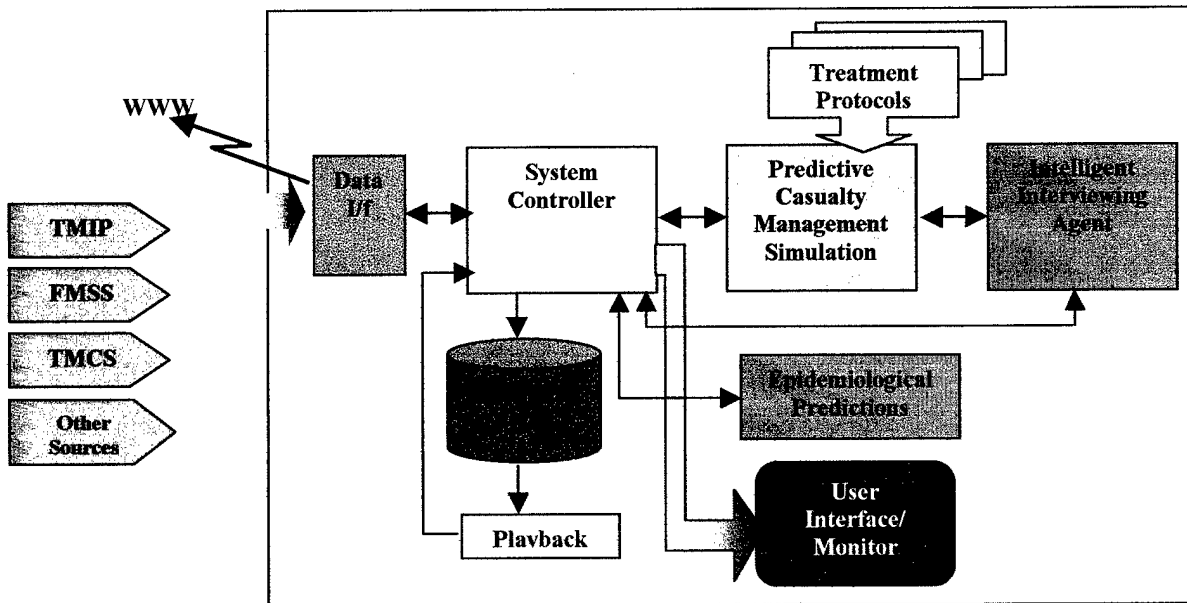

Figure 3. NavMedWatch Components

As described in the Phase I Final Technical Report, the **System Controller** provides the “brains” of the tool. The **System Controller** formats and displays the information on the **User Interface/Monitor**. It compares selected information (such as bed availability) against predetermined thresholds and applies the following color-coding scheme:

- Green represents available resource levels at well below the defined threshold.
- Red represents resource values that are equal to or above the defined threshold.

The System Controller is also responsible for the automatic screen updates and the manual “refresh” functions. The **Data Interface** function formats messages, database queries, etc. that are required in order to access remote data sources. The **Predictive Casualty Management Simulation** (PCMS) takes the current status of the patient load and, using medical treatment protocols (such as Task-Time-Treater files), simulates the flow of casualties over time. The PCMS works by simulating the movement of each casualty through the appropriate treatment protocol while tracking the associated resource consumption. The output of the PCMS is a list of resources required to treat a defined

casualty stream. This list of resources is then compared to the list of available resources for the selected MTF. When resource shortfalls are identified, the **Intelligent Interviewing Agent** uses its knowledge of medical asset availability and medical procedures to identify and display additional or alternate resources. The **Epidemiological Predictions** include links to the charts and graphs produced by the Field Medical Surveillance System (FMSS) as well as Disease or Non-Battle Injury (DNBI) data. Artificial or pre-recorded casualty and resource data can be injected into the system via the **Historical Database** and **Playback** functions of the tool. This enables the NavMedWatch tool to provide a significant level of support for training exercises and after action reviews.

2.0 Research Performed

The research goals for the Phase I Option period (February 23, 2000 to May 23, 2000) were to investigate candidate data sources, to investigate alternate visualization techniques, to continue work in the Application Analysis area, and to investigate the use of Intelligent Agent and Predictive Simulation technologies.

2.1 Data Source Research

After conferring with one of the Technical Advisors for this SBIR contract (Dr. Bill Pugh, NHRC), the decision was made to investigate the TMIP program as a possible NavMedWatch data source. TMIP's goal is to provide informational databases and integration centers that are accessible to the warfighter anywhere, anytime, in support of any mission.¹ The TMIP data investigation involved 1) determining the TMIP database schema and external interface and 2) determining the data available with the TMIP Block 1 delivery versus the data proposed to be displayed by the NavMedWatch tool.

Research indicated that TMIP is divided into three subsystems, each with its own database. The first subsystem is known as the Medical Services Delivery System (MSDS) located at each individual MTF. The database associated with the MSDS is known as the Local Database (LDB). Users can access the LDB through the Persistent Interface (part of the MSDS) using XML (Extensible Markup Language). XML provides a format for describing structured data similar to the way HTML provides a format for visual displays. XML is a text-based format, similar to HTML, designed specifically to store and transmit data. The second subsystem is known as the Headquarters Transactional Processing System (HTPS) located at the JTF Command and Control center. The database associated with the HTPS is referred to as the Interim Theater Database - Online Transaction Processing (ITDB-OLTP). As with the MSDS-LDB, users can access this database via the Persistent Interface using XML. The ITDB-OLTP database stores data from MSDS-LDB to provide summary MTF status to JTF personnel. The third subsystem is known as the Headquarters Analytical Processing System (HAPS) also located at the JTF. The database associated with the HAPS is referred to as the ITDB-Operational Data Store (ITDB-ODS). This database periodically receives data from the ITDB-OLTP to act as a historical database for the theater. Again, this database can be accessed via the Persistent Interface using XML.

¹ Theater Medical Information Program Operational Requirements Document, pg. 1-1.

Figure 4 illustrates an example configuration of the interface linking NavMedWatch and the three TMIP subsystems.

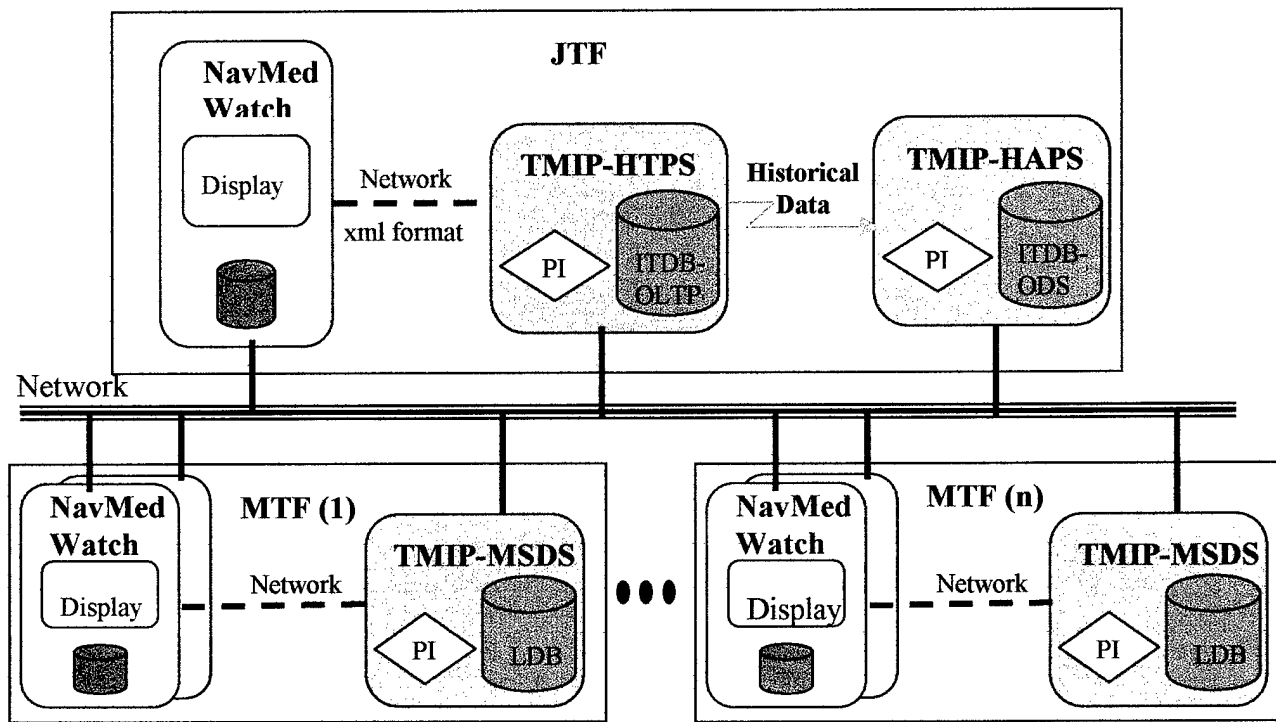

Figure 4. NavMedWatch and TMIP Interface

The three TMIP Block 1 database schemas were studied to determine if the proposed data is readily available. Figure 5 lists the NavMedWatch data to be displayed, the appropriate NavMedWatch screen, location of the data within the TMIP databases, the TMIP Requirement Number², and an alternate data source (if the required data is not currently part of the TMIP databases).

Data	Screen	TMIP Databases (LDB and ITDB-OLTP) Tables	TMIP Req. Number	Alternate Source
is available	Bed/Room Avail & Patient Status	Facility, Room, HS Room Type, Bedspace, OPR BS Stat	FB 47.1, SN 25.1	
	Bed/Room Avail & Patient Status	Facility, Room, HS Room Type, Bedspace, OPR BS Stat	FB 47.1, KA 455.3	
		Facility, Room, HS Room Type, Bedspace, OPR BS Stat	FB 47.1, SN 25.1	
		Facility, Room, HS Room Type, Bedspace, OPR BS Stat	FB 47.1, KA 455.3	

² TMIP Functional Requirements document.

N99-025 Real-Time/Predictive Medical Data Fusion Watchboard

Staff availability	Bed/Room Avail & Patient Status	Facility, Room, HS Room Type (need more info)	FT.17.1	
	Bed/Room Avail & Patient Status	Facility, Room, HS Room Type (need more info)	FT.17.1	
	Bed/Room Avail & Patient Status	Facility, Room, HS Room Type, Bedspace, OPR BS Stat	FB.47.1, SN.25.1	
		Facility, Room, HS Room Type	FB.47.1, KA.455.3	
		Facility, Room, HS Room Type, Bedspace, OPR BS Stat	FB.47.1, SN.25.1	
		Facility, Room, HS Room Type, Bedspace, OPR BS Stat	FB.47.1, KA.455.3	
			SN.25.1	
			KA.455.3	
	Bed/Room Avail & Patient Status	Facility, Room, HS Room Type, Bedspace, OPR BS Stat	FT.17.1	
	Bed/Room Avail & Patient Status	Facility, Room, HS Room Type, Bedspace, OPR BS Stat	FB.47.1, SN.25.1	
		Facility, Room, HS Room Type, Bedspace, OPR BS Stat	FB.47.1, KA.455.3	
		Facility, Room, HS Room Type, Bedspace, OPR BS Stat	FB.47.1, SN.25.1	
		Facility, Room, HS Room Type, Bedspace, OPR BS Stat	FB.47.1, FG.31.1, KA.455.3	
		Facility, Room, HS Room Type, Bedspace, OPR BS Stat	FB.47.1, SN.25.1	
		Facility, Room, HS Room Type, Bedspace, OPR BS Stat	FB.47.1, KA.455.3	
Staff Available	Staff	not available in Block 1		
Staff On Duty	Staff	not available in Block 1		
Supporting Staff by Area	Staff	not available in Block 1		
Staff Allocated	Staff	not available in Block 1		
Patient Status - Triage	Triage	Facility, Room, HS Room Type, Bedspace, OPR BS Stat, Recip, PERSON, HSE Recip, HSER HLTH STAT, HSE RECP	AD8.1; AF.3.1; SR.355.3	

N99-025 Real-Time/Predictive Medical Data Fusion Watchboard

Patient Status - X-ray	X-ray	Facility, Room, HS Room Type, Bedspace, OPR BS Stat, Recip Stay, Person, HSE Person, HSER HLTH STAT, HSE RECP	AD8.1; AF.3.1; SR.355.3	
Patient Status - Lab	Lab	Facility, Room, HS Room Type, Bedspace, OPR BS Stat, Recip Stay, Person, HSE Person, HSER HLTH STAT, HSE RECP	AD8.1; AF.3.1; SR.355.3	
Patient Status - Exam Rm	Exam	Facility, Room, HS Room Type, Bedspace, OPR BS Stat, Recip Stay, Person, HSE Person, HSER HLTH STAT, HSE RECP	AD8.1; AF.3.1; SR.355.3	
Patient Status - Recovery Rm	Recovery Rm	Facility, Room, HS Room Type, Bedspace, OPR BS Stat, Recip Stay, Person, HSE Person, HSER HLTH STAT, HSE RECP	AD8.1; AF.3.1; SR.355.3	
Patient Status - Ward	Ward	Facility, Room, HS Room Type, Bedspace, OPR BS Stat, Recip Stay, Person, HSE Person, HSER HLTH STAT, HSE RECP	AD8.1; AF.3.1; SR.355.3	
Patient Status - ICU	ICU	Facility, Room, HS Room Type, Bedspace, OPR BS Stat, Recip Stay, Person, HSE Person, HSER HLTH STAT, HSE RECP	AD8.1; AF.3.1; SR.355.3	
Patient Status - Pre-OP	Pre-Op	Facility, Room, HS Room Type, Bedspace, OPR BS Stat, Recip Stay, Person, HSE Person, HSER HLTH STAT, HSE RECP	AD8.1; AF.3.1; SR.355.3	
Patient Status - OR	OR	Facility, Room, HS Room Type, Bedspace, OPR BS Stat, Recip Stay, Person, HSE Person, HSER HLTH STAT, HSE RECP	AD8.1; AF.3.1; SR.355.3	
Patient Status - DOR	DOR	Facility, Room, HS Room Type, Bedspace, OPR BS Stat, Recip Stay, Person, HSE Person, HSER HLTH STAT, HSE RECP	AD8.1; AF.3.1; SR.355.3	
Incoming Patient Status	Incoming	HS Order Evac HSO	FC1.1	
Incoming Patient Arrival Time	Incoming	HS Order Evac HSO	FC1.1	
Incoming Patient Pre-Op	Incoming	HS Order Evac HSO	FC1.1	
Evac Patient Status	Evacuation	HS Order Evac HSO		
Evac Patient Arrival Time	Evacuation	HS Order Evac HSO		
Evac Patient Location	Evacuation	HS Order Evac HSO		
Evac Patient Destination	Evacuation	HS Order Evac HSO		

N99-025 Real-Time/Predictive Medical Data Fusion Watchboard

DNBI data (disease, #, %Rate)	DNBI Rates	DNBI_DSGN, Person	FT.15.1; FT.23.1	
DNBI Referral Task Force Compl)	DNBI Rates	DNBI_DSGN, Person	FT.15.1; FT.23.1	
DNBI Reporting Period	DNBI Rates	DNBI_DSGN, Person	FT.15.1; FT.23.1	
DNBI Threshold Notification	DNBI Rates	DNBI_DSGN, Person	FT.19.1	
Personnel At Risk (Epid)	DNBI Rates		KA.227.1	FMSS
Blood Supplies	Blood Supplies		SN.173.1	DBSS
Qty Blood Ordered	Blood Supplies		SN.173.1	DBSS
Blood Exp. Date	Blood Supplies		SN.173.1	DBSS
Est. Blood Req 7 days	Blood Supplies		SN.173.1	DBSS
Identified Bottlenecks	Sensitivity Analysis		KA.237.1; FM.75.1	CasFlow
Time to Shortfall	Sensitivity Analysis		KA.237.1; FM.75.1	CasFlow
Suggested Alternatives	Sensitivity Analysis			Watchboard software calculation
Class VIII-A Supplies Qty Req	Class VIIIA Supplies		FM.40.1; KA.582.1; SN.57.1	DMLSS (no external I/f)
Class VIII-A Supplies Qty Avail	Class VIIIA Supplies		FM.40.1; KA.582.1; SN.57.1	DMLSS (no external I/f)
Class VII-A Supplies Qty Ord	Class VIIIA Supplies		KA.582.1	DMLSS (no external I/f)

Figure 5. TMIP Availability of NavMedWatch Data

Information associated with situational awareness (such as bed availability and patient status) is captured in the TMIP databases; however, the staffing information (such as personnel availability and allocation) is not available with the TMIP Block 1 delivery. An alternate source for this information will need to be identified. The alternate source may require adding a manual data input feature to NavMedWatch allowing this information to be manually entered and stored in a local database.

Research during the Option period also indicated data shortfalls in the areas of blood and Class VIII supply. Information regarding inventories is required to support the Predictive Simulation function. This information is not currently stored in the TMIP databases. The TMIP functional requirements for this area are satisfied by using external components (DBSS for blood supply inventories and DMLSS for Class VIII supply inventories). These components do not currently provide the external interfaces needed to link NavMedWatch to their data stores.

The **Identified Bottlenecks** and **Time to Shortfall** data elements (part of the Sensitivity Analysis screens) are generated using CasFlow. Under U. S. Navy SBIR funding, ScenPro, Inc. has developed a Casualty Flow simulation tool (CasFlow) that can simulate the movement of casualties through an MTF and record the consumption of associated resources over time (space, staff, equipment, supplies, and transportation). During Phase II of this effort, CasFlow will be incorporated into the NavMedWatch architecture to provide predictions of resource needs.



2.2 Visualization Research

As part of the Option period tasking, candidate display techniques for NavMedWatch were analyzed and recorded. Based on knowledge acquisition and prototype evaluation funded under the Defense Advanced Research Projects Agency (DARPA) Biological Warfare Defense (BWD) Program, the Viewport tool was analyzed in depth. ViewPort is an interactive tool, developed by ScenPro, to support Commanders, Planners, and Emergency Responders with enhanced situational awareness and visualization capability during critical incidents over time. ViewPort provides a visual representation of a defined area of interest using underlying electronic maps and Computer-aided drawing (CAD) files annotated with icons. The icons can be easily customized to represent personnel, resources, hazards, alarms, etc. Figure 6 represents an example Viewport screen with custom icons to the left of the map object.

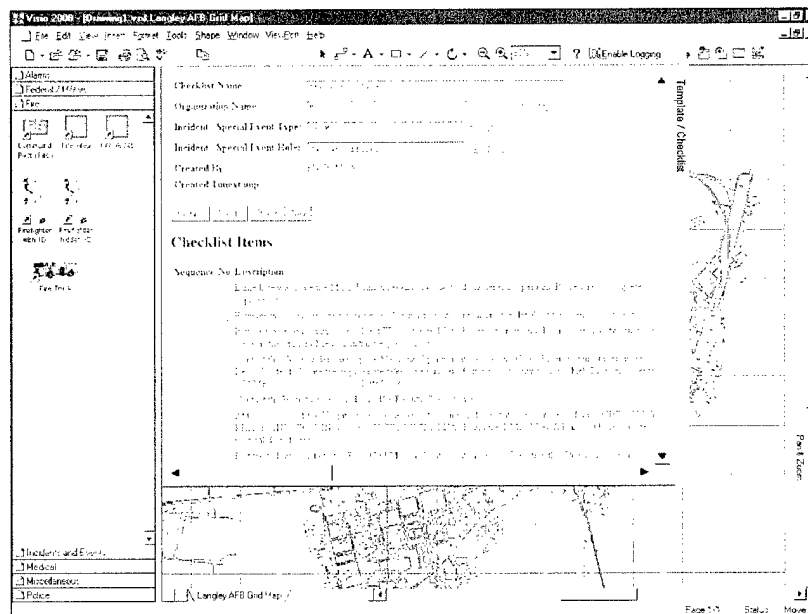

Figure 6.0 Example ViewPort Display

The ability to provide an intuitive, custom display of critical medical data will be incorporated into the NavMedWatch Phase II workplan. Specific areas of interest pertaining to NavMedWatch include: 1) the use of custom, domain-specific icons, 2) application of drag and drop functionality, and 3) the use of an underlying map display. Each NavMedWatch screen could be represented with a unique icon so that the user at the primary NavMedWatch site could drag and drop areas of interest onto the main display - thus allowing the user to in effect create a custom view of the selected medical system. With the use of the underlying map, MTF icons can be placed at the appropriate geographical locations creating a map of the Theater of Operation. This map can be used to show evacuation routes, evacuation status, modes of transportation, etc. At the JTF level, a user could double click on individual MTF icons to bring up detailed characteristics of individual facilities.



2.3 Application Analysis Research

Additional research was conducted into the application of the Scenario-based Engineering Process (SEP) to support this SBIR project. SEP consists of three engineering steps: 1) Domain Analysis, 2) Application Analysis, and 3) System Implementation. The Application Analysis step includes scenario generation and analysis, functional model development, object oriented analysis and design, and performance analysis. During the System Implementation step, ScenPro will implement the new system while providing regular feedback to shareholders.

Much of the work performed in the Phase I effort (May 1, 1999 – October 31, 1999) was focused on the Domain Analysis area as illustrated in Figure 7.

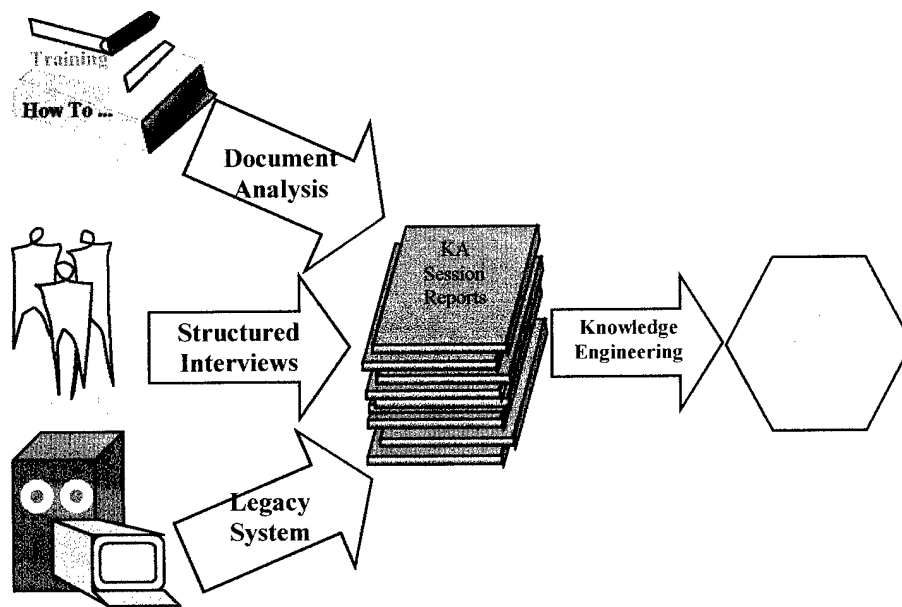

Figure 7. Domain Model Generation

During the Phase I Option period, research was performed in the Application Analysis area. Figure 8 illustrates the tasks involved with Object Oriented Analysis and Design during the Application Analysis phase of SEP:



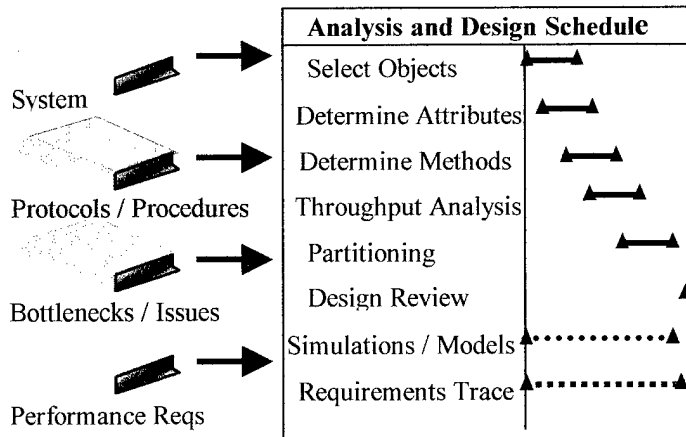

Figure 8. Object Oriented Analysis and Design

The “Select Objects” and “Determine Attributes” tasks included identifying and describing the different components of NavMedWatch as described in the Section 1.1 NavMedWatch Components. Figure 3 shows the key components of the tool. Specifically, we worked with the Data Interface, System Controller, and the User Interface/Monitor. Example attributes identified for the User Interface/Monitor are export path, refresh rates, screen layout parameters, color guidelines, hyper-link navigation, and user profiles.

An on-going task of Applications Analysis is to create simulations and/or models. This work included: 1) expanding the TMCS-type interface prototype developed during Phase I to include an xml-type interface needed to retrieve data from the TMIP databases; and 2) developing a prototype using Visio and VBA. The prototypes are discussed in greater detail in Section 3.0 Prototype Development.

2.4 Predictive Simulation Research

NavMedWatch will include CasFlow, a discrete event simulation previously developed by ScenPro, Inc. The CasFlow simulation has a variety of uses, but the original one was to evaluate the appropriateness of a medical treatment facility (MTF) and its resources for a particular set of casualty streams.

To operate CasFlow in this mode there are three sets of data that are brought together and fed into the discrete event simulator; first, an MTF is designed, including its layout, staff, equipment, and supplies. Second, one or more casualty streams are generated (either by hand or using casualty rate data and a stochastic model) and fed into the simulator. And third, a set of Task-Time-Treater (TTT) files representing the treatment protocol for each injury called out in the casualty streams.

The CasFlow simulation works by taking each casualty and moving them through the MTF in accordance with the steps indicated in the TTT. Each entry in the TTT file describes a task, the staff, equipment, and supplies required to perform the task, the location the task should be performed, and the time the task takes. Whenever a particular

task in the treatment protocol is completed the simulation finds the next task in the TTT and the casualty is moved to the appropriate location in the MTF and staff and equipment are applied to the task. During the task various supplies are consumed. If either the room, staff, or equipment is unavailable, the casualty must wait or be evacuated out. The casualty continues to use the room, staff, and equipment for the indicated time.

As the casualties move through the MTF their triage category is used to allocate the scarce resources. Each casualty is "competing" with other casualties on a "highest triage category first" basis.

During the simulation, data files are created indicating what transpired in each room and to each casualty. When the simulation is complete, these data files can be analyzed to determine how much of various resources are required to properly treat all the casualties. By comparing these requirements with the MTF's on-hand resources, shortfalls can be identified.

The CasFlow simulation engine will be integrated into NavMedWatch and used to predict resource usage and shortfalls. The basic operation of this component of NavMedWatch will be to periodically pre-load the CasFlow engine with information about the current casualties - including patient condition, original admit time, and current location. Configuration details about the medical treatment facilities are also provided to CasFlow.

Using the Task-Time-Treater database, CasFlow will then simulate the treatment protocols for these patients, recording resource use and consumption. The simulation will look several weeks into the future as the current casualties are treated and evacuated out of the theater.

The resources required by the casualties will be compared to those available within the MTFs. Users will be notified about any shortfalls. The user will be able to query the system to understand why the shortfall is expected to occur. The user can also pursue solutions to alleviate the shortfall using the Intelligent Agent component.

Users will be able to enter proposed solutions to the resource shortfalls and rerun the simulation. This will help the users to determine if their solutions will minimize the problem.

2.5 Intelligent Agent Research

The job of the Intelligent Agent is to offer recommendations about how to reconcile predicted resource shortfalls. The function is invoked by the user in the direct response to a shortfall predicted by the Predictive Simulation function.

Based on research performed during the Option period, Intelligent Agent technology could be applied by accessing information associated with individual MTFs, outlined shortfalls, and end-user characteristics. For example, Intelligent Agents could be used to select among pre-defined "Help" files to aid the user. These "Help" files will be based on perceived need, level of education, etc. Additionally, information will consist of



optional courses of action that can be taken to alleviate shortfalls and provide a set of associated recommendations. The recommendations provided by the agents may include checklists, contact information, expected outcomes, possible side effects, and help with report writing. In addition to MTF and user data, characteristics that might be used to choose between different recommendations include: DEFCON, Op Tempo, Pers Tempo, and geographic location.

In order for the Intelligent Agents to be effective, recommendations, key decision points, constraints, and rules must be gathered from subject matter experts. After various recommendations are identified and documented, a representative set of experts will characterize them according to priority, applicability, and probability that the action will be taken. These activities will take place during the knowledge acquisition activities outlined in the Phase II work plan.

3.0 Prototype Development

During the Phase I portion of this project, a prototype tool was created to simulate the interface between NavMedWatch and TMCS. This prototype involved writing an Active Server Page (ASP) using Visual Basic and HTML, to open a Microsoft Access database, query the database, and then write the requested data to a web page. In this case, the user is viewing the NavMedWatch displays with an Internet Explorer browser, and then requesting input data (such as TMCS) across the network from a Microsoft Access database. The NavMedWatch displays were built using HTML.

In the Phase I Option time period, the prototype was modified in order to 1) experiment with Visio™ as the mechanism for building the displays and 2) to simulate an interface to a TMIP database using XML. The system configuration for the prototype is illustrated in Figure 9. Note that the primary NavMedWatch has Visio installed and uses it to create the customized screens. The primary watchboard then exports the different screens as HTML pages to the appropriate directory (in this case c:/inetpub/wwwroot). New screens are exported, as HTML pages, when the Main_MTF display is selected. The remote NavMedWatch user views the various screens via an Internet browser. The remote user is a passive one in that the user does not have the drag and drop capability that the primary user has with Visio. However, the remote user still has the double-click functionality.



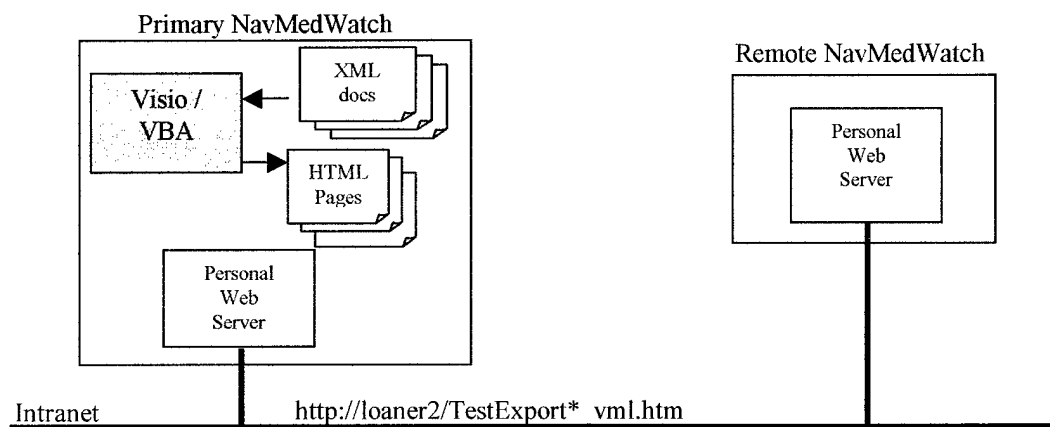

Figure 9. Phase I Option Prototype Configuration

The eXtensible Markup Language (XML), used for interfacing to the TMIP database, provides an application-independent format for storing and defining data by providing a common format for requesting and transferring data using HTTP. In addition, technologies for defining, querying, and rendering XML documents are included. The NavMedWatch prototype demonstrates the use of XML at the client side to request data stored in XML using Microsoft's Rowset schema. The NavMedWatch client reads and parses XML documents defined using the Rowset schema and creates recordsets that contain the requested data. A utility function was built to simulate the creation of the XML documents at the server side. This utility creates XML documents from queries performed on the NavMedWatch example database used in the Phase I prototype.

4.0 Plans for Phase II

4.1 Main Effort

Basic Effort – NavMedWatch Development

The basic effort in Phase II will be the continued development of a Medical Data Fusion Watchboard. This work will build on the prototype tool that was completed during the Phase I and Phase I Option effort. The process of User-oriented Domain Analysis, Rapid Prototyping, and Object Oriented Software Development techniques will continue during Phase II development. Additionally, training applications for the tool will be researched and applied where appropriate.

In the Domain Analysis portion of the effort, an exemplar Scenario-of-Use will be developed. Scenarios are selected to provide a representative sample of training, demonstrating, and testing examples. They identify the details of the incident, casualties, location, events, interactions, individual roles, and outcomes at a high level. ScenPro has created a comprehensive set of CONUS and OCONUS scenarios developed under DARPA and Navy funding. The baseline scenario will be selected from those already available at ScenPro, or developed specifically for this effort if needed. During Domain Analysis, user comments are solicited to optimize the scenario.



Interactions with targeted users will continue and prototypes will be evaluated and refined based on user input. The task analysis documents produced as a result of these sessions will be key drivers in the development of the NavMedWatch tool.

Potential data sources will continue to be researched and evaluated. Current plans will take advantage of the network-based TMCS system as well as available TMIP data. Various devices currently being evaluated for use by the Navy will also be examined – such as Status Monitors, Patient Trackers, and Personal Identification Cards. The data sources selected will be analyzed by users and the Data Fusion Guidelines developed in Phase I will be applied as appropriate. A common database schema capable of storing each datum will be developed and populated with example data, then with data from the baseline scenario.

Once the data are defined and the interfaces have been prototyped and approved, the system will be implemented. As mentioned above, an object-oriented software development methodology will be followed. As optional components are completed, integration testing will be performed and reported.

Option 1 – Addition of Predictive Simulation Functionality

The first Option proposed for this effort is the addition of Predictive Simulation capability. This feature will provide users with the ability to predict casualty movement and resource consumption at the MTF and/or the JTF levels. Based on the results of the simulation, potential resource shortfalls and system bottlenecks will be identified and can be resolved accordingly.

Option 2 – Addition of Epidemiology Functionality

The second Option being proposed for this effort is the addition of an Epidemiology function. This feature will capitalize on current research being conducted at the Naval Health Research Center and will provide users with alerts of potential disease outbreaks and the associated resource considerations. Initial efforts will focus on locating and adopting the most appropriate epidemiological model based on available data stores.

Option 3 – Addition of Intelligent Agent Functionality

The third Option being proposed for this effort is the addition of Intelligent Agent functionality. This feature will provide users with a group of intelligent interviewing agents to assist in resolving resource shortfalls and system bottlenecks. This will have an immediate application in Military Medical Training. (Phase II Option 1 must be included with this feature.)

4.2 Bridge Option

Develop/Adopt Migration Strategies

The proposal for optional bridge funding will focus on the successful development and adoption of a migration strategy for the NavMedWatch Tool during Phase III development.



5.0 Conclusion

The Real-Time/Predictive Medical Data Fusion Watchboard described in this report will significantly enhance the care provided by the current Navy medical system.

NavMedWatch provides medically relevant data in a user-friendly, streamlined format that allows for rapid assessment of the readiness of individual MTFs as well as grouped together within a theater of operation.

The features provided by NavMedWatch will add a high degree of intelligence to the present medical care system - thus making NavMedWatch much more than just a status watchboard. The proposed NavMedWatch tool has the capability of becoming the "standard" for rapidly visualizing and managing U. S. Navy medical operations.

