

VOLUME I

W.S.J  
white  
3/4/66  
W.S.J white

# Natural Resources:

*Energy,*

*Water*

*and River Basin Development*

**DISTRIBUTION STATEMENT A**  
Approved for Public Release  
Distribution Unlimited

Science, Technology, and Development;

UNITED STATES PAPERS PREPARED FOR THE UNITED  
NATIONS CONFERENCE ON THE APPLICATION OF  
SCIENCE AND TECHNOLOGY FOR THE BENEFIT  
OF THE LESS DEVELOPED AREAS

3 TO VIII

Reproduced From  
Best Available Copy

20000602 053

DISTRIBUTION STATEMENTS  
A  
B  
C  
D  
E  
F  
G  
H  
I  
J  
K  
L  
M  
N  
O  
P  
Q  
R  
S  
T  
U  
V  
W  
X  
Y  
Z  
AA  
AB  
AC  
AD  
AE  
AF  
AG  
AH  
AI  
AJ  
AK  
AL  
AM  
AN  
AO  
AP  
AQ  
AR  
AS  
AT  
AU  
AV  
AW  
AX  
AY  
AZ  
BA  
BB  
BC  
BD  
BE  
BF  
BG  
BH  
BI  
BJ  
BK  
BL  
BM  
BN  
BO  
BP  
BQ  
BR  
BS  
BT  
BU  
BV  
BW  
BX  
BY  
BZ  
CA  
CB  
CC  
CD  
CE  
CF  
CG  
CH  
CI  
CJ  
CK  
CL  
CM  
CN  
CO  
CP  
CQ  
CR  
CS  
CT  
CU  
CV  
CW  
CX  
CY  
CZ  
DA  
DB  
DC  
DD  
DE  
DF  
DG  
DH  
DI  
DJ  
DK  
DL  
DM  
DN  
DO  
DP  
DQ  
DR  
DS  
DT  
DU  
DV  
DW  
DX  
DY  
DZ  
EA  
EB  
EC  
ED  
EE  
EF  
EG  
EH  
EI  
EJ  
EK  
EL  
EM  
EN  
EO  
EP  
EQ  
ER  
ES  
ET  
EU  
EV  
EW  
EX  
EY  
EZ  
FA  
FB  
FC  
FD  
FE  
FF  
FG  
FH  
FI  
FJ  
FK  
FL  
FM  
FN  
FO  
FP  
FQ  
FR  
FS  
FT  
FU  
FV  
FW  
FX  
FY  
FZ  
GA  
GB  
GC  
GD  
GE  
GF  
GG  
GH  
GI  
GJ  
GK  
GL  
GM  
GN  
GO  
GP  
GQ  
GR  
GS  
GT  
GU  
GV  
GW  
GX  
GY  
GZ  
HA  
HB  
HC  
HD  
HE  
HF  
HG  
HH  
HI  
HJ  
HK  
HL  
HM  
HN  
HO  
HP  
HQ  
HR  
HS  
HT  
HU  
HV  
HW  
HX  
HY  
HZ  
IA  
IB  
IC  
ID  
IE  
IF  
IG  
IH  
II  
IJ  
IK  
IL  
IM  
IN  
IO  
IP  
IQ  
IR  
IS  
IT  
IU  
IV  
IW  
IX  
IY  
IZ  
JA  
JB  
JC  
JD  
JE  
JF  
JG  
JH  
JI  
JJ  
JK  
JL  
JM  
JN  
JO  
JP  
JQ  
JR  
JS  
JT  
JU  
JV  
JW  
JX  
JY  
JZ  
KA  
KB  
KC  
KD  
KE  
KF  
KG  
KH  
KI  
KJ  
KK  
KL  
KM  
KN  
KO  
KP  
KQ  
KR  
KS  
KT  
KU  
KV  
KW  
KX  
KY  
KZ  
LA  
LB  
LC  
LD  
LE  
LF  
LG  
LH  
LI  
LJ  
LK  
LL  
LM  
LN  
LO  
LP  
LQ  
LR  
LS  
LT  
LU  
LV  
LW  
LX  
LY  
LZ  
MA  
MB  
MC  
MD  
ME  
MF  
MG  
MH  
MI  
MJ  
MK  
ML  
MM  
MN  
MO  
MP  
MQ  
MR  
MS  
MT  
MU  
MV  
MW  
MX  
MY  
MZ  
NA  
NB  
NC  
ND  
NE  
NF  
NG  
NH  
NI  
NJ  
NK  
NL  
NM  
NN  
NO  
NP  
NQ  
NR  
NS  
NT  
NU  
NV  
NW  
NX  
NY  
NZ  
OA  
OB  
OC  
OD  
OE  
OF  
OG  
OH  
OI  
OJ  
OK  
OL  
OM  
ON  
OO  
OP  
OQ  
OR  
OS  
OT  
OU  
OV  
OW  
OX  
OY  
OZ  
PA  
PB  
PC  
PD  
PE  
PF  
PG  
PH  
PI  
PJ  
PK  
PL  
PM  
PN  
PO  
PP  
PQ  
PR  
PS  
PT  
PU  
PV  
PW  
PX  
PY  
PZ  
QA  
QB  
QC  
QD  
QE  
QF  
QG  
QH  
QI  
QJ  
QK  
QL  
QM  
QN  
QO  
QP  
QQ  
QR  
QS  
QT  
QU  
QV  
QW  
QX  
QY  
QZ  
RA  
RB  
RC  
RD  
RE  
RF  
RG  
RH  
RI  
RJ  
RK  
RL  
RM  
RN  
RO  
RP  
RQ  
RR  
RS  
RT  
RU  
RV  
RW  
RX  
RY  
RZ  
SA  
SB  
SC  
SD  
SE  
SF  
SG  
SH  
SI  
SJ  
SK  
SL  
SM  
SN  
SO  
SP  
SQ  
SR  
SS  
ST  
SU  
SV  
SW  
SX  
SY  
SZ  
TA  
TB  
TC  
TD  
TE  
TF  
TG  
TH  
TI  
TJ  
TK  
TL  
TM  
TN  
TO  
TP  
TQ  
TR  
TS  
TT  
TU  
TV  
TW  
TX  
TY  
TZ  
UA  
UB  
UC  
UD  
UE  
UF  
UG  
UH  
UI  
UJ  
UK  
UL  
UM  
UN  
UO  
UP  
UQ  
UR  
US  
UT  
UU  
UV  
UW  
UX  
UY  
UZ  
VA  
VB  
VC  
VD  
VE  
VF  
VG  
VH  
VI  
VJ  
VK  
VL  
VM  
VN  
VO  
VP  
VQ  
VR  
VS  
VT  
VU  
VV  
VW  
VX  
VY  
VZ  
WA  
WB  
WC  
WD  
WE  
WF  
WG  
WH  
WI  
WJ  
WK  
WL  
WM  
WN  
WO  
WP  
WQ  
WR  
WS  
WT  
WU  
WV  
WW  
WX  
WY  
WZ  
XA  
XB  
XC  
XD  
XE  
XF  
XG  
XH  
XI  
XJ  
XK  
XL  
XM  
XN  
XO  
XP  
XQ  
XR  
XS  
XT  
XU  
XV  
XW  
XX  
XY  
XZ  
YA  
YB  
YC  
YD  
YE  
YF  
YG  
YH  
YI  
YJ  
YK  
YL  
YM  
YN  
YO  
YP  
YQ  
YR  
YS  
YT  
YU  
YV  
YW  
YX  
YZ  
ZA  
ZB  
ZC  
ZD  
ZE  
ZF  
ZG  
ZH  
ZI  
ZJ  
ZK  
ZL  
ZM  
ZN  
ZO  
ZP  
ZQ  
ZR  
ZS  
ZT  
ZU  
ZV  
ZW  
ZX  
ZY  
ZZ

---

For sale by the Superintendent of Documents, U.S. Government Printing Office  
Washington 25, D.C. - Price \$1.25

**Preceding Page's Blank**

---

VOL. I. PA20,540

1962

Natural  
Resources

*Energy*

*Water*

*and River Basin Development*

Science, Technology, and Development

UNITED STATES PAPERS PREPARED

FOR THE UNITED NATIONS CONFERENCE

ON THE APPLICATION OF SCIENCE AND

TECHNOLOGY FOR THE BENEFIT

OF THE LESS DEVELOPED AREAS

- 
- Volume I. Natural Resources  
*Energy*  
*Water and River Basin Development*
- Volume II. Natural Resources  
*Minerals and Mining*  
*Mapping and Geodetic Control*
- Volume III. Agriculture
- Volume IV. Industrial Development
- Volume V. Transportation
- Volume VI. Health and Nutrition
- Volume VII. Social Problems of Development and  
Urbanization
- Volume VIII. Organization, Planning, and Programming for  
Economic Development
- Volume IX. Scientific and Technological Policy, Planning,  
and Organization
- Volume X. International Cooperation and Problems of  
Transfer and Adaptation
- Volume XI. Human Resources  
———  
Training of Scientific and Technical Personnel
- Volume XII. Communications

## Foreword

This collection of papers derives from an undertaking unique in the history of international cooperation.

In the spirit of the United Nations Decade of Development, delegations from all the member countries of the United Nations were invited to gather in Geneva, in February 1963, for a conference on the Application of Science and Technology for the Benefit of the Less Developed Areas. The purpose was to discuss, from the viewpoints of the scientist, the technical specialist, the planner, and the policy-maker, the many problems confronting the millions of people whose ways of life are being altered by social, political, and economic change.

All participating countries were invited to submit papers on a wide range of subjects pertinent to the purpose of the meeting. The response was of such magnitude that it was necessary to limit both the number and the length of the papers admitted to the Conference agenda. Since the U.S. Agency for International Development wished to make the total U.S. contribution available for future reference and study, it decided to publish in full all the American papers prepared for the Conference, including many not on the Conference agenda. (Titles of all the volumes in the series are listed on the inside of the front cover.)

In the series will be found contributions from men and women in American universities and foundations, in business, and in government. The authors were chosen as recognized experts and scholars in fields of special interest to developing countries; the opinions expressed in the papers are the authors' own and do not necessarily represent official positions of the U.S. Government. A number of the articles are collaborations of American specialists and professional colleagues from other countries in line with the expressed desire of the Secretary General of the Conference to have joint contributions illustrating the efficacy of cooperative projects.

These volumes supplement an already growing body of literature in the United States on the problems and processes of development, and on the experience and techniques which can be of use to those engaged in planning and carrying forward development activities. As a guide to this literature, the Agency for International Development has prepared a *Selected Reading List*, which briefly describes some 1,200 recently published U.S. books and articles relevant to the subject matter of the Conference. The *Selected Reading List* has been published as a companion volume to this series. Most of the books and articles cited in it have been collected for display at the Technical Library of the Geneva Conference and for subsequent presentation to the Dag Hammarskjold Memorial Library of the United Nations in New York.

The Agency for International Development organized U.S. participation in the Geneva Conference by establishing an *ad hoc* Science Conference Staff, directed by Mr. David Tilson. This staff was a division of the Research, Evaluation, and Planning Assistance Staff, directed by Dr. Edward C. Fei.

In approaching its task, the Science Conference Staff depended for advice and assistance upon a Public Advisory Board, a series of Technical Advisory Panels selected to cover each of the main subject areas on the Conference agenda, and on a Steering Committee consisting of Mr. Harlan Cleveland, Assistant Secretary of State for International Organization Affairs; Dr. Walter Whitman, Science Advisor to the Secretary of State; and Dr. Jerome Wiesner, Science Advisor to the President.

The Public Advisory Board was appointed by the Secretary of State and consisted of the following members: Dr. Walsh McDermott, Cornell University Medical College (Chairman); Dr. Detlev W. Bronk, President, Rockefeller Institute; Dr. Harrison S. Brown, Foreign Secretary, National Academy of Sciences; Dr. Robert A. Charpie, Director, Advanced Projects Research, Union Carbide Company; Dr. Frederick H. Harbison, Princeton University; Dr. J. George Harrar, President, Rockefeller Foundation; Dr. J. Herbert Hollomon, Assistant Secretary for Science and Technology, Department of Commerce; Dr. Allan R. Holmberg, Cornell University; Mr. William A. W. Krebs, Jr., Vice President, Arthur D. Little, Inc.; Dr. Isador Lubin, The Twentieth Century Fund; Dr. Max F. Millikan, Center for International Studies, Massachusetts Institute of Technology; Dr. Robert Morison, Rockefeller Foundation; Dr. Arthur T. Mosher, Executive Director, Council on Economic and Cultural Affairs, Inc.; Dr. Frank Press, California Institute of Technology; Dr. Isidor I. Rabi, Columbia University; Mr. Thomas J. Watson, Jr., Chairman of the Board, International Business Machines Corporation; and Dr. Jerrold R. Zacharias, Massachusetts Institute of Technology.

In the field of natural resources, four Technical Advisory Panels were organized under the auspices of the National Academy of Sciences—National Research Council, with Dr. Harrison S. Brown, Foreign Secretary of the Academy, as general chairman. Stephen W. Bergen, Agency for International Development, served as Scientific Secretary for Natural Resources. The papers for two of these divisions—Energy, and Water and River Basin Development, appear in this volume.

The Technical Advisory Panel for Energy Resources consisted of Mr. Sam H. Schurr, Director, Energy and Mineral Resources Program, Resources for the Future, Inc., Chairman; Mr. Francis L. Adams, Consulting Engineer, Washington, D.C.; Dr. Harold Barnett, Chairman, Department of Economics, Wayne State University; Dr. John W. Boatwright, Consultant, Washington, D.C.; Mr. Robert Brandt, Vice President, New England Power Company; Dr. Hollis Hedberg, Professor of Geology, Princeton University; Dr. James A. Lane, Oak Ridge National Laboratory; Dr. Louis McCabe, President, Resources Research, Inc.; Mr. Harry Perry, Chief, Bituminous Coal Division, U.S. Bureau of Mines; Dr. C. J. Potter, President, Rochester and Pittsburgh Coal Company; Dr. J. K. Roberts, Consultant, New York, N.Y.; Dr. Edwin Gohr, Vice President, Esso Research and Engineering Company; and Mr. Walton Seymour, Vice President, Industrial Development, Development and Resources Corporation. Dr. Jerome K. Delson, Federal Power Commission, served as Scientific Secretary.

The Technical Advisory Panel on Water Resources and River Basin Development consisted of Dr. Abel Wolman, Professor Emeritus of Sanitary Engineering and Water Resources, Johns Hopkins University, Chairman; Dr. Edward A. Ackerman,

Executive Officer, Carnegie Institution of Washington; Dr. Norman H. Brooks, Department of Civil Engineering, California Institute of Technology; Mr. Walter Langbein, Staff Scientist, U.S. Geological Survey; Mr. Theodore Schad, Senior Specialist, Engineering and Public Works, Library of Congress; Mr. George C. Taylor, Jr., Chief, Foreign Hydrology Section, U.S. Geological Survey; Mr. Eugene Weber, Office of the Chief of Engineers, Corp of Engineers, U.S. Army; and Dr. Gilbert White, Professor of Geography, University of Chicago. Mr. Stephen W. Bergen, Agency for International Development, served as Scientific Secretary.

Mr. John H. Durston and Mr. Norman J. Meiklejohn served as editors of this series of volumes, under the general direction of Mr. Abraham M. Sirkin.

## Contents

	Page
Natural Resources Policies and Planning for Developing Countries . . . <div style="text-align: right; margin-right: 20px;">JOSEPH L. FISHER ROGER REVELLE</div>	1
<b>ENERGY;</b>	
INTRODUCTION . . . . . <div style="text-align: right; margin-right: 20px;">SAM H. SCHURR</div>	17
<i>Problems of Electrification</i>	
Experience of the Rural Electrification Administration:	
I. Electrical Distribution Grid Design and Construction for Rural Areas . . . . . <div style="text-align: right; margin-right: 20px;">J. E. O'BRIEN</div>	23
II. The REA Program and the Role of Rural Electric Coopera- <u>tives</u> . . . . . <div style="text-align: right; margin-right: 20px;">J. B. McCURLEY D. H. COOPER</div>	39
TVA's Experience with a <u>Power Utilization Program for Rural Areas</u> . <div style="text-align: right; margin-right: 20px;">G. O. WESSENAUER</div>	55
Some Problems in Initiating Power Supply in Less Developed Areas Based on Case Histories . . . . . <div style="text-align: right; margin-right: 20px;">FRANKLIN J. LEEBURGER</div>	62
Rural Electrification and Rural Development . . . . . <div style="text-align: right; margin-right: 20px;">DALE J. HEKHUIS THOMAS O. PAINE FRANK L. TURNER GEORGE STREET, JR. E. GORDON ALDERFER</div>	74
Typical Problems in the Development of Modern Power Supply in Less Developed Areas . . . . . <div style="text-align: right; margin-right: 20px;">WALTON SEYMOUR</div>	83
<i>Coal: Mining and Efficiency in Use</i>	
Practical Application of <u>Coal Mining Technology</u> to Projects in Less Developed Areas . . . . . <div style="text-align: right; margin-right: 20px;">F. R. ZACHAR</div>	97
Metallurgical, Domestic, and Industrial Utilization of Low-Rank Coals . . . . . <div style="text-align: right; margin-right: 20px;">W. S. LANDERS</div>	108
Auxiliary Injected Blast Furnace Fuels . . . . . <div style="text-align: right; margin-right: 20px;">J. H. STRASSBURGER</div>	119

*Oil: Achieving Productive Capability*

	Page
Financing Oil Expansion in the Development Decade . . . . .	137
EDWARD SYMONDS	
Economics and Design of Smaller Petroleum Refineries . . . . .	149
G. B. ZIMMERMAN	
Recent Developments in the Design of Small Refineries . . . . .	155
R. E. BITTNER	
G. P. BAUMANN	
A. R. CROSBY	

*Nuclear Energy*

Nuclear Power Technology and Costs . . . . .	163
FRANK K. PITTMAN	
U. M. STAEBLER	

*The Economics of Choice Among Alternative Energy Sources*

Economic Criteria for Evaluating Power Technologies in Less Developed Countries . . . . .	177
RICHARD A. TYBOUT	
Energy Cost Comparisons . . . . .	202
PERRY D. TEITELBAUM	
Techniques for Appraising the Energy Economy and Outlook in Less Developed Countries . . . . .	223
NATHANIEL B. GUYOL	

**WATER AND RIVER BASIN DEVELOPMENT**

INTRODUCTION . . . . .	233
ABEL WOLMAN	
New Steps Toward Better Data and Investigation for Water Resources Development . . . . .	238
E. L. HENDRICKS	
W. B. LANGBEIN	
G. C. TAYLOR, JR.	
Community Water Systems in the United States . . . . .	254
ABEL WOLMAN	
HERBERT M. BOSCH	
The Community Water Supply Development Program of the Agency for International Development . . . . .	269
A. DALE SWISHER	
Low Cost Waste Treatment—Waste Stabilization Ponds . . . . .	282
EARNEST F. GLOYNA	

	Page
River Basin Planning in the United States . . . . .	299
EUGENE W. WEBER	
MAYNARD M. HUFSCHMIDT	
Advances in Techniques of Ground-Water Resources Development . .	313
DAVID K. TODD	
Exploration for Ground Water, Northeast Thailand, 1952-1962 . . .	326
HOWARD F. HAWORTH	
Hydrology and Scientific Reclamation in the Punjab, West Pakistan .	332
D. W. GREENMAN	
Making Wise Use of Flood Plains . . . . .	343
GILBERT F. WHITE	
HOWARD L. COOK	
Desalination; Evaporation Reduction; Artificial Precipitation; Large- Scale Weather and Climate Modification . . . . .	360
THOMAS K. SHERWOOD	
HARRY WEXLER	
Education in Hydrology . . . . .	372
JOHN W. HARSHBARGER	

Footnotes, references, selected references and figures appear at the end of the individual articles in which they are cited.

WATER RESOURCES

2000

# Natural Resources Policies and Planning for Developing Countries\*

JOSEPH L. FISHER

*President, Resources for the Future, Inc., Washington, D.C.*

ROGER REVELLE

*Science Advisor, U. S. Department of Interior, Washington, D.C.*

1. Developing countries need to know a great deal about their natural resources of land, energy, water, and minerals, and about the industries, products, and services closely associated with them. They also need to make headway in translating that knowledge into programs of development. These two closely associated goals are important to developing countries because resource industries are dominant in their economic life, because improvement in the resource sectors usually is a prerequisite of escape from situations in which rapid population increase is accompanied by low productivity and income, and because raw-material exports frequently have to be depended on for foreign exchange with which to purchase needed capital equipment. Furthermore, subsequent growth will be conditioned by the pattern of location of population and industry and by the development experiences established during the earlier phases of economic development when natural-resource occurrences and characteristics are more influential.

2. The central purpose of this paper will be to characterize the role of resource policies and plans in the advance-

ment of less developed countries. Resource policies, which are the more general principles and guidelines for development, and resource planning, which translates policies into concrete terms for land, water, energy, and minerals, may be thought of as the connecting links between science and technology on the one side and higher economic and cultural attainments on the other. Of course, natural resources do not tell the full story of economic development; a skilled and capable labor force, capital plant and equipment, an enterprising and well-trained cadre of industrial managers, and impartial and decisive government administration also are vital. In a real sense, however, the whole economic pyramid rests upon raw materials and environmental resources and realization of their potentialities through the application of science and technology.

3. These considerations and others to be examined later have already been found to be of great importance in the developing countries, many of which have been making notable headway in analyzing their resource potentialities and translating them into effective policies and plans. In this paper we shall

\*U.N. Conference paper.

try to summarize the broad objectives of resource policy, to consider the conditions favorable for rapid and sustained progress in resources development, to indicate some principal elements of resource policy making and planning, and to discuss these elements in terms of specific situations in a selected less developed country. Finally, we shall point out several significant problems or obstacles to resource development that are common to many less developed countries.

#### **Characteristics of Resources and Broad Objectives for Their Development**

4. Natural resources differ from capital and other kinds of resources primarily in their relatively fixed geographic location and extent. Many raw materials can be extracted from the ground or harvested from the land and waters, and shipped to distant points for consumption or further processing, but they all begin in a more or less fixed place and exist in finite amounts although neither the precise physical nor the economic extent may be known. There is the further characteristic that most resources are depletable in some sense. Mineral reserves in any particular location are depletable in an absolute sense; that is, they may be used up economically if not physically. The renewable resources of agricultural land, forests, grass lands, and fish populations may be exploited to the point where they can be reestablished only at prohibitively high cost, if at all. Another characteristic is that resources are the first links in the economic chain: resource materials enter technological processes early and then have applied to them varying degrees of fabrication and transportation on

their way to becoming final consumer goods and services.

5. Every country needs to learn what resources it has, what their economic potentialities are, and how to translate mere existence into usable products and services. It must also determine where its comparative advantages lie and how these may change, since it will have insufficient capital, skilled manpower, or other means to develop all its resources in any given time period. This will mean for many countries a continuing concentration on food and fiber production for domestic consumption with less attention to production of mineral or agricultural raw materials for exports. For other countries the reverse will be true.

6. Each country will want to fit its resource-development plans in with broader economic-development plans. This frequently will call for investments and other activities to increase per-man and per-acre yields in agriculture along chosen lines, diminish overall the number of agricultural workers, expand rapidly certain industries which at relatively low levels of capital intensity will make use of easily obtainable raw materials, and expand and diversify the energy base.

7. Economic activity in most of the less developed countries is heavily concentrated in the resource industries compared to more developed countries. In Brazil, for example, about 60 percent of the labor force recently has been engaged in agriculture, forestry, fishing, mining, and quarrying; in India about 70 percent; and in other less developed countries the percentage is even higher. In Italy, Japan, Mexico, and Spain the percentage of the labor force in resource industries has ranged in recent years from 40 to 60, while in the United States it is about 13 percent. National income arising in the

resource industries has also made up the larger part of total national income in nearly all the less developed countries, although the percentages are somewhat lower than those cited for the labor force, principally because of the lower level of labor productivity in agriculture than in industry.

8. Improvements in agriculture and the other basic-resource industries in nearly every instance will be necessary if early stages of economic development are to be followed by diversified industrial development. All economic policies and plans, therefore, will be heavily oriented to resources. Resources, plus transport and basic processing, become the core of development planning to provide food, water, building materials, heat, electric power, and many other items. First attention will be given usually to domestic sources for most of these, although a number of less developed countries have been able to export one or two particular raw materials in which they are especially well-endowed as a means of obtaining yet other raw materials from other countries.

9. With these characteristics in mind, the primary objective of resource policy may be stated. It is to promote the achievement of national objectives through development of land, water, energy, and minerals:

- (a) at least cost;
- (b) on a sustaining basis having in mind the conservation of existing supplies, the discovery of new sources, and the development of cheaper or more plentiful substitutes;
- (c) with a high multiplying effect on further economic development;
- (d) with significant contributions to better relations among nations for the advancement of all;

(e) so as to encourage a wide and equitable sharing of costs;

(f) so as to minimize or offset the difficulties of adjustment in particular regions and among particular groups.

10. Particular resource policies and plans may be tested against these objectives. Obviously these objectives overlap one another, are complex and difficult to determine in precise situations, and involve numerous contradictions. Policies and plans must be compromises among them. For example, least-cost production in agriculture, if pursued relentlessly, might force large numbers of farmers out of agriculture and out of their particular farming regions before they could be re-trained for other economic activities or before programs could be set in motion to aid them in adjusting to living in other communities. The requirements of national defense may also conflict with the least-cost principle. Equitable sharing of costs is most difficult to define since it must be relative to individual values and broad social objectives which themselves are changing.

### **Conditions for Progress in Resources Development**

11. A number of conditions may be laid down for rapid and sustained progress in resource development. These will vary in relative importance from country to country, but will obtain to a significant degree in virtually all places. They include:

- (a) Increasing scientific and technical knowledge about resources, especially those on the more immediate horizon of development.
- (b) An improving professional-education system for increasing the num-

ber of scientists, engineers, economists, industrial managers, administrators, planners, and others; and an improving general educational system in support of citizens' understanding of the part resources can play in economic advance.

(c) Access to world sources of raw and processed materials and to world markets since self-sufficiency is either impossible or at least very costly for all countries.

(d) Some containment, if possible, of the pressure of population, at least in many of the less developed countries.

(e) Reasonably stable government and competent administration.

(f) Willingness to work hard and to save in the interest of more rapid development, to the extent of capacity.

(g) Appropriate help from other more developed nations in finance, real capital, education, and technical aid on a carefully selected and fitted basis.

12. In many ways these conditions set out for progress in resource development are simply the specific application of the more general conditions of economic growth. Resource policies and plans must not only take them into account, but should aim at improvements leading to more effective utilization of new technology through increasing the skill of the labor force, fostering more efficient industrial management, providing lower cost electric power and heat, a better transportation system, and an increase of social capital in many forms.

### Elements in the Resource Planning Process

13. Given the broad objectives for resource development and some knowledge

as to the general conditions which will favor such development, how can the more specific and practical work of resource policy formulation and planning be improved? Two interrelated elements or aspects require consideration: *framework* and *decision*.

14. The *framework* element includes the relevant basic data (geologic, hydrologic, geographic, economic); social patterns and institutions within which resource development has to be worked out; systematic long-range estimates of demand and supply of resource materials as these are related to population estimates and foreseeable technologic changes; and the general goals of national and regional plans. The framework consists essentially of a layout of data, technologic possibilities, alternative supply sources, economic trends, institutional situations, and the like, within which policy and planning decisions are made.

15. The *decision* element focuses on ways in which policy and planning decisions are actually made in public and private sectors of an economy. Decisions regarding broad policies for resources development, long-range development plans and budgets, particular resource projects, and administrative implementation are not clearly separated in practice; there is a continuum of decisions across a band from the more general to the more specific. Attention here will be given to the improvement of resource decisions by such means as benefit-cost, linear programming, and input-output analysis. These techniques can aid in appraising the merits of alternative resource development projects and systems of projects such as river-basin development schemes and industrial complexes. Case studies of existing projects can also lead to improvements in future decisions. This ele-

ment is concerned with the whole process by which decisions are reached; with the political, social, and aesthetic factors as well as the technologic and economic, and therefore with the points of view of various groups and with the conditions that have to be satisfied if their support, or at least acquiescence, in the decision is to be assured. It is not too much to say that the primary objective in resource planning is to establish an efficient decision-making process, important though particular investment and other decisions may be.

16. *Framework.* Resource policies and plans have to be visualized in various contexts: one of the most useful of these contexts is the long-range interrelated projection of demand and supply for resource products and services. Such a set of estimates may be made: first, by projecting the larger economic and demographic aggregates such as population, labor force, gross national product and its major components, and the like; second, deriving from these chiefly on the basis of historical relationships the demand for such resource products as meat, cotton, steel, construction lumber, fertilizer, and the like; and third, calculating the requirements for the basic resources of crop land, forest land, water, energy commodities, and metals from which products in the second stage may be produced. In this manner a bill of requirements for resource products and the basic resources themselves may be worked out within the constraints of anticipated increases in population, work force, productivity, and national production. It will be helpful to work with ranges, probably quite wide ranges for years further into the future, which will embrace a high, a low, and one or more intermediate estimates. Precisely where actual demand falls within

the range will depend on how new technology is applied in industry, how consumer wants shift, the extent to which new sources at home or abroad open up, and the directions and effectiveness of policies designed to change the course of events which otherwise would follow.

17. On the supply side, the estimated requirements would have to be met within the overall constraints imposed by quantity and quality of known and potential natural resources as well as by the technical and economic capacity of the country or area in question to discover, extract, process, transport, and utilize these resources or those it can obtain from other countries. Technology and economics will form the bridge between estimates of demand and the manner in which they are satisfied. With skillful balancing of the variety of supply possibilities with estimated demands, with careful attention to the estimating of net returns of alternative courses of action and to economies of scale, development of the economy can proceed along efficient lines. One of the greatest difficulties in building this kind of framework will be the uncertainties which surround new technology and the rate of application of existing technology, and this is especially true for less developed countries.

18. Such a framework of projections is well-suited for exposing incipient gaps between projected demand and likely supplies, and for making estimates of possible changes in the relative prices of resource products.

19. This kind of exercise has been done for resources in the United States (1). The resource-demand estimates, which are derived from projections of basic demographic and economic aggregates such as labor force and production, have been used as reference points in the

analysis of supply possibilities and difficulties. For example, in the energy-resources field, consumption of all fuel and power, measured in a common unit, is estimated to increase about threefold by the year 2000 compared to 1960, while population is estimated to increase about 85 percent and gross national product by more than four times. Within the total estimated increase in all energy, the shares of the several energy commodities and sources are expected to change. The most dramatic prospective shift will be in atomic energy; relative shifts among the conventional sources of coal, oil, and natural gas will be less marked than during the past century. Demand estimates (perhaps they should be called speculations) show atomic power to increase from virtually nothing in 1960 to 480 billion kilowatt hours in 1980 and 2,500 billion kwh in 2000, by which time well over half of the new electric power installations may be nuclear reactors. These are medium level estimates; a wide range of possibilities exists. The conventional fuel sources of coal, oil, and natural gas are expected to increase also but at much slower rates; by 2000 the demand for oil may increase by three times, natural gas by nearly that much, and coal by about 75 percent.

20. Built into these projections of atomic power and other energy sources are numerous assumed changes in technology, some of them major. Failure to achieve considerable cost reductions in the production of atomic power will mean that conventional energy sources will have to be relied upon much more heavily, or other new sources such as oil shale, tar sands, low-grade coal, and possibly unconventional sources will have to be drawn upon, if the energy sector is to grow in total as projected.

21. Estimates of investment requirements for enlarged raw-material production may be related to projections of demand for the materials themselves. Foreign trade enters into the picture in several ways: foreign demand has to be added to domestic demand for domestic raw materials, foreign supplies have to be subtracted from total supplies needed in order to get what will be required from domestic sources. A long-range, inter-related, demand-supply framework such as has been described can help to set the stage of more realistic resource policies and plans, although it will not specify what the policies and plans have to be. The projections bring major problems into focus and narrow the range of useful courses of action. The working-through of these projections requires at least a minimum knowledge of aggregative demographic and economic trends, of technical relationships between resource inputs and outputs of resource products and services, as well as scientific and technical knowledge about the basic resources themselves. The greater the amount and the higher the quality of such information, the more realistic and useful will be the framework of projections. Wide ranges in the demand estimates will be the better part of wisdom; policies based upon such projections should also be flexible so that they may be altered in the light of unfolding events.

22. Another useful instrument for framework planning is comprehended by the term systems analysis, by means of which a resource complex is stripped of nonessential elements and placed within a model that expresses the significant interrelationships. The principal variables may then be manipulated in such ways that the output or performance of the system can be described quantitatively

and tested against performance criteria. Typically, high-speed computers will be necessary to do this. Systems analysis in this sense has been experimented with, both in theory and in simulated practical applications in a number of resource situations including river-basin development schemes (2). This kind of engineering-economic analysis can throw much light on the efficiency of alternative development programs and, placed in relevant political and administrative formats, can aid greatly in reaching wise decisions. Still other kinds of framework exist or can be constructed—for example, legal, administrative, and institutional—which can aid in placing resource planning in better perspective, but these are not elaborated here.

23. *Decision.* The processes of policy-making and planning are carried on within whatever frameworks (demand-supply systems, legal, institutional, and others) may be constructed. How may these processes be made more effective so that one project or phase of the actual plan that is undertaken may lead easily and logically into the next? Here we are concerned with strategy and sequence, with the smooth meshing of the several parts, in such a way that initial impulses toward development can exert a multiple effect on the economy and the whole plan can move toward fulfillment with a minimum of delays and detours. Especially we are concerned with the way in which policy and planning decisions are made and with their quality and effectiveness. The improvement of decisions is to be achieved partly by better facts and analysis, and partly by improving the way in which facts and analysis are used. On issues of major significance, decisions are governmental decisions in the public sector and top management decisions in the

private sector. Over all are the broad political decisions as to national goals and policies; underlying all are the preferences, motivations, and actions of individuals.

24. Several kinds of analysis may be useful in guiding those who make decisions about policies and plans. One kind which has been used in the United States, especially in the water-resources field, is called benefit-cost analysis. Essentially this comprises the identification of alternative projects for achieving roughly the same purposes, an estimate of the costs which will be incurred over the life of the project, and a comparison of the estimated benefits and costs for each of the alternative projects. Many difficulties arise in this kind of analysis, some of which have to be settled arbitrarily. What shall be the assumed length of life of the project? What would be the appropriate rate for discounting the flow of future benefits and future costs? Should the rate be related to some private market rate of interest or should it be a public or social rate? What course of prices and costs should be assumed for the future? Perhaps most vexing of all is the question of what range of particular benefits and costs should be included in the analysis at all; especially, should those of a more intangible, remote, and social nature be included—and if so in what way?

25. Much attention has been given to benefit-cost analysis in the United States and indeed for most water-development projects Federal law requires that such analysis be undertaken and the result presented to the Congress along with other information about the proposed project. Uniform procedures have been established and form the basis for field investigation of benefits and costs. Questions like those raised here have

been given a good deal of critical attention in recent years, and as a result benefit-cost estimating techniques have been refined, somewhat more sharply delimited, and in general made more understandable and useful. Benefit-cost estimating for alternative-resource development projects may also be helpful in less developed countries although lack of a competitive price system including a money market, the large size of many projects in relation to the resources available for accomplishing them, and the necessary emphasis on social purposes make the technique clumsy and ineffective in many instances unless it is severely limited to appraising the merits of specific alternative projects, for example, dams of different heights or in nearby locations.

26. Also of use in less developed countries may be the input-output kind of analysis in which the sectors of the economy are viewed in terms of the relationship between the input of resources and other items on the one side and the output of final products and services on the other side. Data can be gathered and organized in such a way that the coefficients expressing these relationships may be calculated and a matrix established. It then becomes possible to assume a mix of final outputs and calculate the inputs that will be required to give the desired results. Such a schema can be used to estimate the effects of alternative paths of national development; regional input-output matrixes would permit the testing of larger scale resource projects.

27. Several difficulties arise at once: a considerable amount of technical and economic data are needed, although to some extent the input-output technique can be used with a minimum of data; the technical coefficients relating inputs and outputs may change especially in countries

growing rapidly and shifting toward more industry and more mechanized farming. This technique, however, does enable broad appraisals and comparisons of different sets of resource-development projects to be made.

28. A more narrow and focused variant of this approach is the linear programming model in which outputs of particular items, for example, are regarded as a function of a number of independent and variable factors. With the relevant data inserted, such systems of equations may be manipulated in various ways and made to yield solutions which are optimal in terms of selected criteria. Other analytical methods useful in improving decisions include game and queueing theories, simulation, minimax and related techniques.

29. In addition to these more technical means for improving policy and planning decisions, we must call attention to the importance of the way in which data and analysis are handled at the points of decision. Essentially this is a matter of organizing and bringing forward various kinds of evidence bearing on the policy or the plan in such a way that a comprehensive and balanced picture is made available to the decision-makers at the time the decision has to be made. The evidence obviously will include engineering and economic analysis, and it should also include broad social, political, and aesthetic argument. The broader the policy or plan under consideration, the more general will be the evidence and argument. The more narrow and focused the policy or plan, the more specific and perhaps quantitative it can be. Finally, there can be no substitute for well-trained, politically and socially sensitive persons in the decision-making positions—persons who will be able to bring

together the various plans and analyses with a keen appreciation of the conditions which will have to be met if necessary support is to be obtained. Policy-making and plan-making at the higher and more general levels tend to be political acts concerned with the public sector or the regulation of the private sector. In national planning as carried out in most of the less developed countries, the scope and general role of the private sectors are also marked out in the plan so that the larger private resource decisions are embraced by and consistent with the public decisions.

#### **Resources Planning and National Development: An Example From Pakistan**

30. Resource policy and planning have to be viewed in the full context of national development if they are to serve that cause effectively. A development strategy must pull together the natural resource potentialities with the available manpower and capital resources in a dynamic program for resource and national development. Particular attention should be given to shortages and obstacles of a general economic nature (e.g., insufficient savings, foreign exchange, or trained manpower) and to those related more closely to natural resources (e.g., low agricultural productivity, high-cost energy materials for heat and power, or undeveloped mineral resources). Insufficient or poor quality data for better resource planning frequently will be the first obstacle.

31. The interrelationships involved in resource planning for national development and the need for a development strategy may be illustrated in the case of agriculture in many of the less developed countries where yields are depressingly

low and have not risen very much in recent years. Usually more than one factor of productivity limits yields: lack of water at the right place and time, sometimes too much water, not enough fertilizer, farms too small in size, and others. An integrated and concentrated attack on these factors is needed and will involve communication with farm operators, social and economic analysis, as well as much applied agricultural research, and better administration of agricultural programs. Achievement of initial momentum is essential but not at the cost of foreclosing future possibilities. Above all, a strong economic motivation on the part of farm operators and workers must be created. Program and expenditure choices usually exist—for example, development of surface versus underground water, or new agricultural land versus more intensive cultivation of land presently farmed. In laying the basis for wise choices, interrelated social, economic, and engineering analysis, frequently using modern techniques such as those mentioned earlier, can be highly effective.

32. Many of the principles of resource development and the kinds of analysis useful in resource planning are revealingly illustrated by the problem of agriculture in West Pakistan.<sup>1</sup> The flat, fertile Indus Plain, most of which lies in West Pakistan, contains the largest single irrigated area on earth. With its sandy and silty soils, year-round growing season, large surface flow of water, highly developed system of irrigation canals, huge underground reservoir of fresh water, underground pools of natural gas, and a wide range of crops that can be grown, the Plain is one of the chief physical assets of the world's fifth most populous country. Yet, despite its potentialities, incomes from agriculture remain very low,

and there is a deficit of both calories and animal proteins in the diet of the people. Population is increasing more rapidly than food production.

33. One of the problems of agriculture in West Pakistan is waterlogging and salt accumulation in the soil, caused by poor drainage in the vast, nearly flat Plain. Agricultural production is also held down by a shortage of irrigation water. Because of canal seepage and other losses, only about half the water diverted from the rivers is available to crops. Much of the planted area receives too little water to prevent salt accumulation. Chemical fertilizers, protective measures against plant diseases and pests, and high-yielding plant varieties are very little used. Other handicaps are the system of land holding and primitive methods of cultivation.

34. In establishing the framework for agricultural development, the need to raise present per capita food production by 30 to 40 percent and the range of probable population growth in West Pakistan of between 50 and 100 percent over the next 25 years must be considered. Increases in sugar and cotton production will be required to meet the demand of both East and West Pakistan. As living standards rise, the relative demand for fruits, vegetables, and livestock products will grow. Additional increases in agricultural production will have to be based on export markets or industrial use of farm products.

35. Maps of the mechanical composition, salt content, and cation-exchange characteristics of the soils are needed, not only as a basis for determining cropping patterns, but also for planning capital expenditures for development. For example, the high salt and sodium contents of the soils in much of the Indus Delta region raise serious question concerning

the economic potentials of these lands. Considerable further investigation is needed to determine the areas of fresh and saline underground water, and the chemical composition of the salt water. Much of the latter has a sufficiently low salt content so that it can be used for irrigation when diluted with fresh canal waters.

36. A plan for greatly increasing agricultural production is being devised by means of which technological possibilities can be brought into effective relationship with economic feasibilities and human capabilities. In the northern two-thirds of the Plain, the supply of irrigation water for actual consumptive use by plants can be doubled, in part by river regulation through surface storage, but chiefly by constructing a network of carefully spaced tubewells to recover canal seepage and allow controlled mining of the underground water. The tubewells will also make it possible to leach the accumulated salts out of the soil and ultimately to eliminate waterlogging.

37. Yields per acre can be increased by providing more irrigation water and water at the right time, by the use of fertilizer, by controlling plant diseases and pests, by the development and use of improved seed and crop varieties, and by the introduction of better cultivation practices. Each of these five production factors may increase yields 20 percent when applied singly, but in combination they could give increases of 200 to 300 percent. In order to integrate all the factors of production, it is necessary to concentrate their application in project areas of manageable size. Analysis of the hydrologic processes involved, and of the economics of fertilizer production, indicate that the project areas should contain about a million acres. If adequate capital and technical manpower can be made available, it

should be possible to initiate development of a new million-acre project each year.

38. Linear programming analysis shows that the principal benefit from the tubewell water will come from the maximum possible expansion of the planted areas during the summer season in the most profitable crops.

39. Electric power for pumping water can be obtained either by hydroelectric development in the mountains and foothills of the north, or by thermal plants using natural gas. West Pakistan is fortunate in having fairly large reserves of natural gas, which can be used also as a source of nitrogenous fertilizer. With electricity, phosphate fertilizers can be made from imported raw material.

40. To attain momentum in increasing production, an optimal sequence of capital investment is essential. First expenditures should be for development of underground water and drainage, fertilizer plants, pest-control facilities; training and organization of technicians, administrators, and field workers to assist the farmers; development of better plant varieties; and needed investigations. Later, roads and transportation facilities must be provided to haul a greatly increased volume of agricultural products to the cities and towns. Processing mills and textile factories will have to be built to utilize these products profitably. Still later, a farm-machinery industry will be needed, and factories to produce consumer goods for the farmers will ultimately be required. Only a few conveyance channels to carry off salty waters in order to maintain a salt balance will be needed at first, but many of these relatively expensive structures must be built within about 20 years of the initial development.

41. In the northern two-thirds of the Plain, an initial capital investment of about Rs 260 to 285 an acre is needed in order to allow integrated use of the primary factors of production. Ultimate expenditure may be several times this amount. After full development, the maximum net increase of crop value in the northern area from additional water, fertilizer, plant protection, and presently existing better plant varieties, could be Rs 3.6 million, equal to twice the average gross production during the last decade, excluding livestock.

42. All aspects of the program rest on vigorous education and agricultural extension efforts to guide the farmers in carrying out their part of the task, ample credit to make the farmers' participation possible, and efficient marketing and distribution facilities. Massive and determined effort, and continuing experimentation, will be necessary to transmit new technical skills to very large numbers of desperately poor and illiterate farmers, and to create economic conditions in which they will be motivated to help themselves.

#### **Some Common Problems of Resource Development**

43. A few common problems of resource development in less developed countries may be listed here. Some are theoretical; some are practical. Research and experimentation offer the best avenues for dealing with them. The kinds of analysis suggested in this paper seem promising. These problems include:

- (a) Improving the amount and quality of resource data, both scientific and economic, and further testing of ana-

lytical methods so as to make the data more useful in planning.

(b) Determining a strategy of resource development in national economic growth. What are the main elements of such a strategy? What variables are critical for forward motion and how may they be manipulated? What sequence and combinations of industrial investment, workers' training, agricultural improvement, and occupational and regional shifts are called for in each country for the resource sectors?

(c) Interrelating more closely the food and raw material shortages in some countries with surpluses of production or capacity in others.

(d) Devising workable international arrangements for financing resource development, for market and price stabilization, and for technical aid in resource planning.

(e) Finding an effective division between public and private sectors with appropriate interrelating of the two. The line of division will, of course, vary from country to country according to its particular history and present situation.

(f) Appropriate safeguarding of the productiveness of basic resources, such as soil and water, and of the quality of the natural environment.

(g) Adjusting to the declining relative importance of agriculture and some other resource industries in national economies. This will involve a balancing of programs for raising agricultural efficiency (better farming practices, improved processing and marketing of crops, more machinery and power, better health and education, more credit) with programs of industrialization, principally in urban areas.

(h) Adopting cost-reducing technology in resource activities as rapidly as possible.

44. Within each country, and perhaps within each subnational development region, an organizational means for resource-development planning, at least for the coordination of such planning, will be beneficial. Some countries have such arrangements; others do not. Typically this will mean drawing together representatives from a number of departments or agencies of the government spanning the various natural resources of land and agriculture, forestry, fisheries, water and power, energy, minerals, and the like so that comprehensive and multiple-purpose policies and plans may be worked out. In many countries, this may be done within or in conjunction with national and regional planning bodies. To begin with, data gathering and research in the resources field should be coordinated and given central attention.

45. Since common problems of resource policy-making, planning, and development are to be found in one form or another in virtually all less developed countries, and since the more developed countries will also have to take some part in solving them, frequently through the use of analytical techniques as described in this paper, there would appear to be much to be gained from a more concerted attack on them than has thus far been made. We suggest, therefore, that consideration be given to the establishment of a World Resources Development Institute with the following purposes:

(a) To undertake, and to stimulate others to undertake, scientific, technologic, statistical, and economic research on natural resources, especially as such research bears on policy and planning.

(b) To foster exchange of information, and perhaps to establish a central library of knowledge.

(c) To encourage the education and training of resource specialists through seminars, fellowships, exchanges of personnel, and the like, working in relation with existing universities and public and private institutes.

(d) To build an international panel of resource specialists for technical aid in water, land, energy, and minerals, with emphasis on the planning of developments in these fields.

(e) To cooperate with various groups concerned with resources, including other international agencies,

national and subnational organizations, and appropriate private groups.

46. Direction of such an institute could be by an international board of world leaders in the resources field, of scientists, engineers, planners, economists, administrators, and educators. Possibly the national academies of science or some similarly respected bodies could act as sponsors. Financing might come from participating countries or organizations, foundation grants, or from the United Nations or its specialized agencies concerned with resources. The institute could be a part of the United Nations, or it could be outside the U.N. but cooperating with the U.N. and certain of its specialized agencies.

#### FOOTNOTE

<sup>1</sup> The following discussion is based on the work of the U.S. White House-Interior Panel on Waterlogging and Salinity in West Pakistan, undertaken in 1962.

#### REFERENCES

(1) Landsberg, Fishman, and Fisher, *Resources in America's Future*, to be published in the spring of 1963 by the Johns Hopkins Press for Resources for the Future, Inc.

(2) Maass, Hufschmidt, Forman, Thomas, Marglin, and Fair, *Design of Water-Systems* (Harvard University Press, Cambridge, 1962).

ENERGY

## Introduction

It is a commonplace observation that economic development goes hand in hand with an increase in the use of inanimate energy sources. The modernization of techniques of production, and especially the development of manufacturing and efficient transportation facilities, places a heavy demand on fuels both as a source of mechanical power and of heat for a variety of industrial processes. Not least in importance from the standpoint of welfare is the use of energy for improving the comforts of life, whether it be electricity to light homes and public facilities and to power small appliances, or fuels for cooking and heating purposes.

Although there is an obvious connection between improved standards of living and the increased use of energy, there is not a strict relationship between a country's level of economic welfare and the quantity of energy it consumes. There are wide differences among countries, and even within a single country in different stages of its development, in the amounts of energy consumed in relation to the total national output of goods and services. It must be recognized also that increased use of energy is not the causal factor in economic development. It is merely one element, albeit an indispensable one, in a process which involves change and growth in many economic, social, and political functions, as is attested by the breadth of the agenda of this conference.

The papers collected in this volume present the views of a number of American specialists on how to deal with some of the important problems which will be encountered in less developed areas in expanding and diversifying energy production and use. An effort has been made to cover the different sources and forms of energy which will be important as economic development proceeds.

### Problems of Electrification

The expansion of the use of electricity is an objective all developing countries seem to have in common. Because such countries face a special problem in bringing electricity to their rural areas, several of the papers here presented deal with this question.

The United States has had a relatively recent and eminently successful experience in electrifying its own rural areas, and several aspects of the American experience are described. Two of these papers are written by officials of the Rural Electrification Administration. One, by O'Brien, describes some of the new departures in design and construction which were introduced in this country to increase the economic feasibility of rural electrification. The other, by McCurley and Cooper, explains the methods and institutions used to increase both the demand and supply of electricity in rural areas, activities originally designed to insure that the benefits of electricity were realized by farmers. The latter theme is also developed in the paper by Wessener of the Tennessee Valley Authority; he describes the demonstrations and the

educational and other activities undertaken in the Tennessee Valley region to encourage the use of electricity for farm uses. An important additional reason for fostering demand was to reduce the unit costs of power generation and distribution.

The experience of the United States may be useful to other countries as they seek to improve the efficiency of electricity distribution, and also in their approach to the problem of creating conditions for the effective use of electricity on farms. The conditions in many of the less developed areas, however, may be sufficiently unlike those in the United States to require methods and institutions differing in significant respects from those used in this country. One essential difference is that the American program dealt with isolated farm dwellings, while the problem in other countries may concern the village.

The problems of village electrification are dealt with in two other papers in this collection, both written by authors with firsthand experience. The Leerburger paper presents a series of case studies in different countries in which the problem of village electrification is an important element. The paper by Hekhuis and his associates presents the results of field studies of the village electrification problem in India and Latin America. Both papers deal with the circumstances needed to make village electrification an economic proposition.

A different type of question arises in the paper by Seymour. He is concerned with the problem of how to achieve an efficient electric power system on a regional basis. The author discusses a number of successful cases with which he was associated and shows the administrative, financial, and organizational changes made in certain regions to achieve an efficient electric power system.

### **Coal: Mining and Efficiency in Use**

Coal is one of the primary energy sources used in the generation of electricity, and in many direct industrial and household applications. Resources of coal are widely distributed throughout the world, and despite the inroads of oil and natural gas, coal is still the single most important world energy source. The quantity now produced in the world is on the order of two billion tons per year, which accounts for about one-half of the world's commercial energy supply. There is no inherent reason for world coal production not to continue to grow in the future, particularly if techniques, such as some of those referred to in the papers in this volume, are successfully applied.

Two papers dealing specifically with coal are offered. The one by Zachar is concerned with coal mining; the paper by Landers is devoted to the problem of upgrading coals of low quality to make them suitable for more effective use. A third paper, by Strassburger, describes recent improvements in blast-furnace techniques which, in addition to other advantages, result in economies in the use of coking coal.

Zachar discusses certain broad considerations which must be kept in mind in adapting tried mining techniques of developed countries to areas in which the relevant experience (as well as supporting industrial and service facilities) may be lacking. For example, machines for use in areas where repair parts are not readily available might be selected for ruggedness at the expense of other qualities. Similarly, there may be a high premium on standardization of machines, which would

sacrifice efficiency in matching a machine to a job, in order not to burden personnel with the task of mastering a wide variety of different machines.

Among the coal resources of the world, those of low rank—brown coal, lignite, and subbituminous coals—are widely distributed. Their utilization has been limited, however, by poor chemical and physical properties. Landers discusses techniques that would permit the extensive use of such coals in the modernization of less developed areas. His paper indicates that uses which would appear to be technically unlikely for low-rank coals have already been rendered feasible by methods which have been developed for improving quality. Included among the applications in which low-rank coal, suitably upgraded, can be employed are such important uses as iron-ore reduction, railroad transportation, electric-power generation, cement production, and domestic heating and cooking. Landers discusses the techniques of upgrading which make the poorer coals suitable for such applications.

Iron-ore reduction is an especially important use of coal. In almost all current practice it requires metallurgical coal suitable for coking, a type of coal which is in limited supply in many parts of the world. Strassburger deals with ways of economizing the use of coke in the blast furnaces through the injection of auxiliary fuels. He describes the important changes in experimental and commercial blast-furnace practice in recent years which have seen auxiliary injected fuels replace a sizable percentage of the metallurgical coke otherwise required. As a concomitant of reduced coke requirements there has also been a reduction in capital requirements—resulting partly from the need for fewer coke ovens—and lowered costs for pig-iron production. The various fuels that can be used to supplement coke, and the techniques for so doing, are described in some detail.

### **Oil: Achieving Productive Capability**

The energy consumption of the world is being met to an increasing extent by oil supplies. The share of oil in the world's total consumption of commercial energy has increased from less than 20 percent before the war to about 30 percent at the present time, and its relative importance in the less developed areas is considerably greater. In view of the growing importance of oil, and its position as the leading energy source moving in international trade, many countries with favorable geological conditions are ambitious to become crude-oil producers. However, as indicated in Symond's paper, the costs of entering this phase of the oil industry are very great. Symond also shows what the various sources of investment funds have been, and notes the different approaches to oil financing available for achieving capability in crude-oil production.

To acquire capacity for the refining of oil is a different sort of problem. Many countries, with or without indigenous crude-oil resources, want local refineries for a variety of reasons. A difficult problem is that in less developed areas the refinery capacity needed is much smaller than what is normally considered economic. There are very great cost increases per unit of capacity in building smaller plants because larger plants are not simply multiples of these smaller units.

Zimmerman in one paper, and Bittner and his associates in another, report on the experiences of two American companies in reducing the costs associated with small refineries by tailoring plant design to the special needs of the local market.

Although neither paper presents the technical detail needed for design purposes, both describe the methods by which significant cost reductions can be achieved.

### **Nuclear Energy**

Nuclear fission is the newest of the primary energy sources that appears to hold substantial promise for widespread future use. Its history to date, so far as peaceful energy applications are concerned, has been confined essentially to experiment and development. The pre-commercial phase appears, however, to be drawing to a close, and it is important to consider nuclear energy as a possible alternative to other energy sources in future power-system planning in less developed areas.

The paper on this subject, an authoritative statement by Pittman and Staebler, two officials of the U.S. Atomic Energy Commission, briefly summarizes the relevant facts as of the autumn of 1962. The paper presents the latest American estimates of the competitive status of nuclear power compared to power produced in conventional plants. It shows how greatly the competitive position of the nuclear electric plant worsens as its size declines from several hundred megawatts to 50 or 20 megawatts. In this connection the authors present estimates showing that among alternative types of nuclear power plants, those using natural uranium as a fuel are far more sensitive to the diseconomies of smaller scale than are plants using slightly enriched uranium.

### **The Economics of Choice Among Alternative Energy Sources**

The proper choice among alternative investments poses an unusually important problem for the less developed areas because of their extreme shortage of capital compared to their vast needs. The importance of a correct choice is enhanced by the fact that investments in plant and equipment often draw on scarce resources of foreign exchange.

The Tybout and Teitelbaum papers deal with the problem of choice among different techniques for producing electric power in a less developed area. The Tybout paper presents a methodology broadly relevant to the problem of choice among alternative investment possibilities, and indicates how this general approach might be applied in the power field. This would involve development of a technique for (a) measuring the costs and benefits of investment alternatives and (b) reducing both costs and benefits, which for different investments will be realized at different times in the future, to a common basis of present values.

The Teitelbaum paper has a more limited objective: the problem of choice between nuclear and conventional thermal power. It is important in such choices to recognize those differences between nuclear and conventional thermal power plants which significantly affect the terms of the comparison. Thus, the paper shows that to assume the same lifetime use factor for both types of power stations may lead to erroneous results. The different structure of costs of the nuclear plant might lead to its being used to meet base load demand over a longer period of time than will the conventional plant, resulting in a higher lifetime use factor for the nuclear plant. Teitelbaum also warns that power cost-accounting conventions used in the United States may be quite incorrect in less developed areas.

The problem of economic choice depends also on the availability of adequate background information bearing on investment and other planning decisions. Those who must cope with energy planning in less developed areas are severely handicapped by

the absence of basic information on the present structure of the nation's energy economy. In his paper, Guyol proposes a systematic approach to the organization of information by way of an energy balance sheet. This is a consolidated account for all sources of energy used during a particular time period expressed in common units, tracing each source of energy from its origin to effective use. A balance sheet recently completed for India is included in his paper.

SAM H. SCHURR

*Director, Energy and Mineral Resources Program.*

*Resources for the Future, Inc.*

*Washington, D.C.*

## *Problems of Electrification*

### Experience of the Rural Electrification Administration: I—Electrical Distribution Grid Design and Construction for Rural Areas

J. E. O'BRIEN

*Director, Electric Standards Division, Rural Electrification Administration,  
U.S. Department of Agriculture, Washington, D.C.*

1. The purpose of this paper is to describe some of the significant rural distribution experiences in the United States with the hope that they will be useful in the development and expansion of rural electrification in other parts of the world. The experiences referred to in this paper took place in the program of the Rural Electrification Administration. However, the design and construction of rural power systems in the United States are quite similar, whether done by the Rural Electrification Administration (REA) borrowers or by investor-owned power companies.

2. The upsurge in rural electrification in the United States began in 1935, in a

period of economic depression. Stimulation of the economy was an important objective of the expansion of rural electrification. Under the pressures of a depressed economy, the usual types of distribution line construction employed in cities, towns, and villages were entirely too expensive to be used in rural areas. In these circumstances, there was a tremendous incentive to attain lower construction costs. This was essential if rural electrification was to go forward. Had it been a time of prosperity, there might have been no incentive to reduce costs. The lesson REA learned is that in applying rural electrification to a new situation, one should not be afraid to

break with tradition. The important thing is to design to fit the present and the future, not the past. This represents an interesting and stimulating challenge where there is no large existing system creating a firm foundation of engineering tradition. Where there is a tradition of power system design and construction practices, the challenge is infinitely greater, because human inertia is a powerful force. And only engineers of vision and determination can overcome this force.

3. In the United States, the farmers live on their farms rather than in villages. The farms are quite large, generally averaging 300 acres or more. The typical rural distribution system serves a relatively large geographical area which is usually uniformly and lightly loaded. The average system serves 5,000 consumers with 1,500 miles of distribution line. (However, some rural systems serve over 25,000 consumers.) In a representative situation, about three farms are served by each mile of distribution line. The loads are predominantly single-phase in character, although there may be a few three-phase installations located within the area. Towns, villages, and cities usually are served by separate distribution facilities. Figure I shows a section of rural area served by a distribution substation. The typical rural system load is growing rapidly and requires good voltage regulation and a high level of service continuity.

4. These factors have a major influence on the design and construction of the rural distribution system. The preponderance of single-phase loads has led to systems essentially single-phase in construction and operation, approximately 80 percent of the lines being single-phase. The system which has evolved is typically

an overhead multigrounded neutral radial system on wood poles using relatively small conductors, usually aluminum with steel cores (ACSR).

5. The most common voltage is 7,200 volts phase-to-ground or 12,470 volts phase-to-phase. In sparsely settled areas which are remote from power sources but where the individual farm loads are heavy, and occasionally under other conditions, it has been more economical to use 14.4/24.9 kv as a distribution voltage.

6. Compared with other types of systems, the multigrounded neutral system offers a number of distinct advantages for serving the area described above. Long-span, single-phase branches may be constructed most economically in vertical configuration as shown in figure II. This is the basic line-supporting structure used in U.S. rural electrification. With the addition of a crossarm, this structure permits conversion of a single-phase line to a two-phase circuit or a three-phase circuit when such changes are required. These structures are shown in figure III. On single-phase multigrounded neutral circuits, the neutral carries only 30-40 percent of the phase current. In effect, the earth becomes a conductor in parallel with the neutral and the voltage drop and conductor losses are reduced accordingly. Since 80 percent of the rural lines in the United States are single-phase, the economic advantage of the multigrounded neutral system is obvious.

7. Economies exist also in equipment requirements. Transformers with only one high-voltage bushing are satisfactory and it is necessary to use only one primary fuse cutout and one primary lightning arrester. Since a transformer is usually required for each rural consumer, these reduced requirements result in sig-

nificant economies. An installation of this type is shown in figure IV.

8. The capability of the distribution system generally is limited by voltage drop rather than permissible current carrying capacity. Good voltage levels are obtained by limiting the voltage drop on the primary to a maximum of 7 percent (or 8 volts on a 120-volt base). Voltage regulators of the step type are used at the substation to maintain the feeder voltage within satisfactory limits. The voltage drop on the grid is held within design limits by limiting circuit lengths, selecting an adequate conductor size and by the use of line voltage regulators as necessary. However, the system is essentially designed without the use of line regulators, which generally are relied upon to defer additional investment for growth until it is economical to make the investment.

9. A satisfactory degree of service reliability is obtained principally by means of a very effective system of sectionalizing. Automatic circuit reclosers, automatic line sectionalizers and, to a limited extent, fuses are used at frequent intervals to isolate any fault which may occur. The sectionalizing devices trip for temporary faults and then reclose rapidly to restore service. Since temporary faults account for more than 90 percent of all faults, a very high degree of reliability can be obtained by this means. If the fault persists, the device closest to the fault will lock open. It then becomes necessary to locate and remove the fault and reset the sectionalizing device. Single-pole sectionalizing devices are most commonly used and effect a higher degree of service reliability compared to three-pole devices, inasmuch as a fault on one phase does not interrupt service on the other phases. The single-pole automatic circuit recloser was developed to meet the specific needs of rural

distribution systems. These needs were for a sectionalizing device that would operate for long periods without servicing and at the same time would be less expensive than the traditional type of circuit breaker. Figure V shows the installation of a single-pole automatic circuit recloser.

10. The system is considered to be adequately grounded if there are four ground connections in each mile of line. REA specifications require a driven ground at each equipment installation, at secondary dead ends, and, including all driven grounds associated with the primary, every 1500 feet or less along the line. On many systems pole-protection grounds are added to protect the pole from lightning. Although not considered to meet U.S. National Electrical Safety Code requirements in themselves as system or equipment ground connections, these grounds contribute to the effectiveness of the grounding of the neutral. Common primary and secondary neutrals are usually employed and all other grounds, including guy wires, are bonded to the neutral. As a rule, no attempt is made to reduce the resistance of the individual grounding electrode. Even in areas of very high resistivity, experience has shown that the overall resistance of the multigrounded neutral is very low—usually less than three ohms.

11. The experience of rural distribution systems operating in close proximity to telephone or other communication systems has been very satisfactory. The two systems frequently parallel each other at roadside separation, and in addition a large amount of line is built with the telephone and electric systems sharing the same pole. No special construction is required for the electric distribution system but the transformers used are

built to a specification which controls the harmonic content of the excitation current. Telephone companies in the United States have determined that the most satisfactory method of operating is to adopt very high construction standards which result in a telephone system characterized by a very low susceptibility to power-line influence. Under these conditions, the telephone companies do not consider it necessary to request special construction from the power systems for the purpose of reducing power-line influence.

12. As mentioned above, U.S. rural distribution lines are primarily single-phase. The principal reason for this is the fact that most rural loads are single-phase. The average farmstead has no three-phase requirements. Most farm motors, including those used for feed grinding, are under 5 horsepower. However, the larger and deeper irrigation wells frequently require pump motors of 25 horsepower or larger, and, for these, three-phase service is provided. In the past, 7½ horsepower was generally regarded as the largest practical single-phase motor and the cost of this size motor was about twice as much as a comparable three-phase motor. However, in the United States, it is believed that it is more economical for some users to spend several hundred dollars for an occasional motor than to require the alternative expenditure which would be borne by all of the consumers of thousands of dollars for three-phase lines. United States manufacturers are becoming interested in larger single-phase motors which will perform as well and cost no more than three-phase motors. One company manufactures a 30-horsepower single-phase motor which compares favorably in cost and performance with three-phase

motors. Many U.S. rural systems have the capacity to serve 30-horsepower single-phase motors without undue flicker problems. In fact, single-phase loads no longer are limited to any specific size; the present practice is to allow the capability of the system at the point of installation to determine the maximum size of the single-phase load than can be served.

13. As shown in figure I, a typical rural grid consists of radial feeders which leave the substation as three-phase circuits with each of the phases fanning out to serve the countryside as a single-phase circuit. Since most rural loads can be served satisfactorily by single-phase circuits, this arrangement has resulted in worthwhile economies. Not only is the cost of conductor reduced but savings are also effected by the elimination of all other equipment associated with the additional phase conductors. In the United States, a three-phase line costs approximately 50 percent more than a single-phase line. The costs shown below, as an illustration, were taken from a recent system plan for a rural electric cooperative in the Midwest:

<i>Description of Line</i>	<i>Cost per Mile</i>
Single-phase No. 4 ASCR.....	\$1,215.00
V-phase No. 4 ACSR.....	1,664.00
Three-phase No. 4 ACSR.....	1,900.00

14. Recognizing differences in rural population, economic levels, and labor costs, what are some of the lessons to be gained from experience of the United States? Certainly, long-span construction should receive major attention. By the use of high-strength conductors, the number of poles or towers per mile can be significantly decreased with corresponding reductions in costs. Single-phase, multigrounded circuits reduce the cost of serving individual farms, and

should be examined as a possible grid design for serving groups of villages.

15. The use of standardized assemblies, called construction units, has facilitated the mass construction of lines financed by REA. Construction units are a convenient means of describing the construction to be performed. They are also used as bidding units when the construction is performed by contract and as a means of inventorying the completed construction. These construction units are the building blocks for complete line construction. For example, a pole of specified size, with the labor required to install it, is one unit. A length of guy wire of specified size with associated clamps or grips and the required labor is another. These construction units are described in detail, with drawings, in construction standards for distribution and transmission line construction. (The standard for 7.2/12.5 kv distribution line is titled REA Form 804, "Specifications and Drawings for 7.2/12.5 kv Line Construction.")

16. Simplified mapping procedures and simplified staking methods reduce construction cost. Uniform, simple maps, using standardized symbols reduce engineering costs and facilitate construction. Such maps can be used by workmen with a minimum of training and experience. Construction of REA projects requires the preparation of two maps: (a) a key map which shows the primary line as simply as possible in addition to important physical and geographical features, and (b) a detail map. In addition, the latter shows the primary lines, transformers, secondary lines, service drops, the locations of consumers to be served and potential consumers in the area, sectionalizing devices, phasing and wire sizes, and the telephone and telegraph

lines. An example of a detail map is shown in figure VI. Figure VII shows a staking sheet. The engineer places stakes in the field to show the location of the poles. Each stake bears a number and this number appears as the pole number on the staking sheet. Opposite the pole number is indicated all the material and equipment mounted on the pole—the standard construction units. Thus, the maps, the staking sheet, and the standard drawings provide the construction crew with all the information needed to construct a line. Staking is simplified through the use of staking tables prepared by conductor manufacturers. Figure VIII is an example of such a staking table. Profile levels usually are not taken for the staking of distribution lines, although in unusually rough terrain this may be advisable. Transits are used to place the stakes in a straight line.

17. Standardization has been a factor of great importance in U.S. experience. Standards permit diversity of manufacture; encourage competition; permit a high degree of interchangeability of equipment; and reduce the cost of system design, construction, and operation. But standardization must be dynamic, keeping in step with developments in equipment and engineering practices.

18. In the United States, lessons were learned also from mistakes and miscalculations. Some experimentation was conducted with single-conductor, ground-return, single-phase circuits. This was done in the early days of World War II when conductor was in short supply. Single wire ground return lines were built in some areas where a high level of ground moisture existed. To provide an acceptable level of safety with a single wire circuit the grounds must be very reliable and are relatively expensive. In

the usual rural system the grounds are quite simple and inexpensive, and reliability and safety result from the large number of inexpensive grounds connected to the common neutral. In areas where consumers are served along the line, and where therefore a large number of individual transformer grounding installations is required, the cost of the more elaborate grounds largely offsets the savings resulting from the elimination of the neutral conductor. However, in countries where farmers live in villages rather than on individual farms, and where the primary grid connecting the villages is to be a single-phase system, the elimination of the grounded neutral might offer a worthwhile saving. In this situation, with transformers at only the ends of the feeders, the cost of obtaining the few reliable grounds required might not be significant.

19. The use of local unskilled labor for the manufacture and installation of poles made from native timber, and the clearing of right-of-way by volunteer workers, turned out to be less than entirely satisfactory. In the case of the poles, native timber was used and was processed by the consumers served by the power systems. This method was initially a success, mainly because of the savings in pole costs; however, within a few years it proved to be not worthwhile when the poles began to decay. Subsequent investigation revealed that the poles were installed without proper preservative treatment and had to be replaced after about 5 years. Another plan involved the application of the "self-help" principle to reduce the cost of line construction in low-income areas. Under this plan members of the electric cooperatives were employed as unskilled and semiskilled laborers for work such as right-of-way clearing and hole digging.

The success of endeavors such as those just described requires the use of practical enforceable standards for equipment, materials and workers' performance. If standards can be maintained and if construction time schedules are not critical, there is a good possibility of success in using local unskilled and semiskilled workers.

20. The possibility of developing local industries for the manufacture, fabrication, assembly, and processing of materials and equipment used in distribution-line construction merits serious consideration. The most notable example in the United States is in the manufacture of wood poles and crossarms. Particular attention is called to American experience with softwood species. These nondurable woods are easy to treat with preservative and, when properly treated, last for 30-40 years. Wood poles and crossarms are easy to manufacture, easy to modify in the field, and possess excellent resistance to natural hazards when properly manufactured. In areas where timber resources do not exist the feasibility of developing such a resource by a forestation program merits consideration. In a relatively short span of years a resource can be developed which will be useful not only for poles and crossarms, but for other products as well.

21. The manufacture of wood poles can be accomplished with the simplest equipment. Logs can be cut, hauled out of the forest, peeled, and framed with tools and facilities generally available in rural areas. As the need arises these operations may be mechanized. Depending on the preservative treatment required by a particular wood species and the treatability characteristics of the species, the facilities may range from a simple open-vat dipping process to a more com-

plicated thermal process using two vats, one hot and the other cold, to a still more complicated pressure system. For the pressure system several manufacturers have available package units consisting of the pressure cylinder, necessary storage tanks, control equipment, and piping. The operation of such a system would require trained personnel. One such package unit is shown in figure IX.

22. Similarly, pole-line hardware requires relatively simple manufacturing facilities and might lend itself to development as a local industry. Somewhat more complicated, but still in the realm of possibility, is the production of distribution transformers, using tanks, cores, coils, bushings, etc., manufactured elsewhere but assembled in a local plant.

### Summary

23. A review of rural electrification experience in the United States leads to the conclusion that the following factors merit consideration for rural electric systems in developing nations.

24. Where there is little existing electrification, the opportunity for imaginative

engineering exists, unhampered by the tradition of existing practices.

25. Significant economies may be obtained by using long-span construction, multigrounded circuits, and single-phase primary feeders.

26. Costs may be minimized by the standardization and simplification of equipment, materials, structure designs, and construction practices.

27. Local unskilled workers may be used in line construction, provided construction standards are maintained and construction time-schedules are not critical.

28. Some of the equipment and materials used in line construction may be manufactured, processed, or assembled locally. Of particular interest is the manufacture of preservatively treated wood poles and crossarms.

### Acknowledgement

29. The author is grateful to Messrs. L. B. Crann, E. A. Loetterle, J. A. Taylor, J. N. Thompson, S. J. Vest, and R. G. Zook, Electric Standards Division, Rural Electrification Administration, for their assistance in the preparation of this paper.

### SELECTED REFERENCES

The following REA bulletins are of engineering interest. Titles have been omitted to save space. These bulletins, with their titles, are listed in the Index of Current REA Publications and are available upon request from the Rural Electrification Administration, U.S. Department of Agriculture, Washington 25, D.C.

REA Bulletins Nos. 40-4, 40-6, 41-1, 43-5, 44-1, 44-2, 44-3, 44-4, 44-7, 45-1, 45-2, 45-6, 60-1, 60-7, 60-8, 60-9, 60-10, 61-1, 61-2, 61-4, 61-5, 61-6, 61-8, 62-1, 65-1, 80-4, 80-5, 81-9, 83-1, 112-1, 161-4, 161-5, 161-6, 161-7, 161-8, 161-9, 161-12, 161-14, 161-17, 161-19, 161-22, 165-1, 168-6, 169-1, 169-4, 169-9, 169-11, 169-24, 169-27, and 169-30.

REA Forms 803, 804, 805, and 830, which contain construction drawings, specifications and contract terms, are also available from REA, along with other forms listed in Part IV of the Index of Current REA Publications.

The publications listed below are available from the organizations named at the head of each group.

- McGraw-Hill Book Company, 330 West 42nd Street, New York, New York:  
Knowlton, A. E., *Standard Handbook for Electrical Engineers*, 9th Edition (1957)  
Kurtz, E. B., *The Linemen's Handbook*, 3rd Edition (1955)  
Hunt, G. M., *Wood Preservation*, 2nd Edition (1953)  
Sanford, F. E., *Electric Distribution Fundamentals*, 2nd Edition  
Shrotzki, B. G. A., *Electric Transmission and Distribution*  
Shrotzki, B. G. A., *Electric System Operation*  
Stafford, H. E., *Troubles of Electrical Equipment*
- John Wiley & Sons, Inc., 440 Park Avenue South, New York 16, New York:  
Miner-Seaslone, *Handbook of Engineering Materials*  
Mason, C. R., *The Art and Science of Protective Relaying* (1956)
- General Electric Company, Pittsfield, Massachusetts:  
*Distribution Transformer Manual*, GET-2485 (1959)  
*Application Manual of Overcurrent Protection for Distribution Systems*
- Rome Cable Division, Aluminum Company of America, Rome, New York:  
*ACSR Rural Lines Design Data* (1960) with *Staking and Stringing Sag Tables* (1960)  
*The Rome Cable Manual of Technical Information*
- Westinghouse Electric Corporation, East Pittsburgh, Pennsylvania:  
*Electric Utility Engineering Reference Book, Vol. 3—Distribution Systems* (1962)  
*Applied Protective Relaying*  
*Silent Sentinels*, Westinghouse Protective Relays (1949)  
*Westinghouse Architects and Engineers Electrical Data Book*
- Edison Electric Institute, 420 Lexington Avenue, New York 17, New York:  
*Underground Systems Reference Book*
- American Standards Association, Inc., 10 East 40th Street, New York 16, New York:  
*Guide for Installation and Maintenance of Oil-Immersed Transformers*, Appendix C57.93
- National Fire Protection Association, 60 Batterymarch Street, Boston 10, Mass.:  
*National Electrical Code* (1962)
- Superintendent of Documents, U.S. Government Printing Office, Washington 25, D.C.:  
*Safety Rules for the Installation and Maintenance of Electric Supply and Communication Lines*, National Bureau of Standards Handbook 81 (1961)  
*Copper Wire Tables*, National Bureau of Standards Circular 31, 4th Edition (1956)  
*Wood Handbook*, Agriculture Handbook No. 72

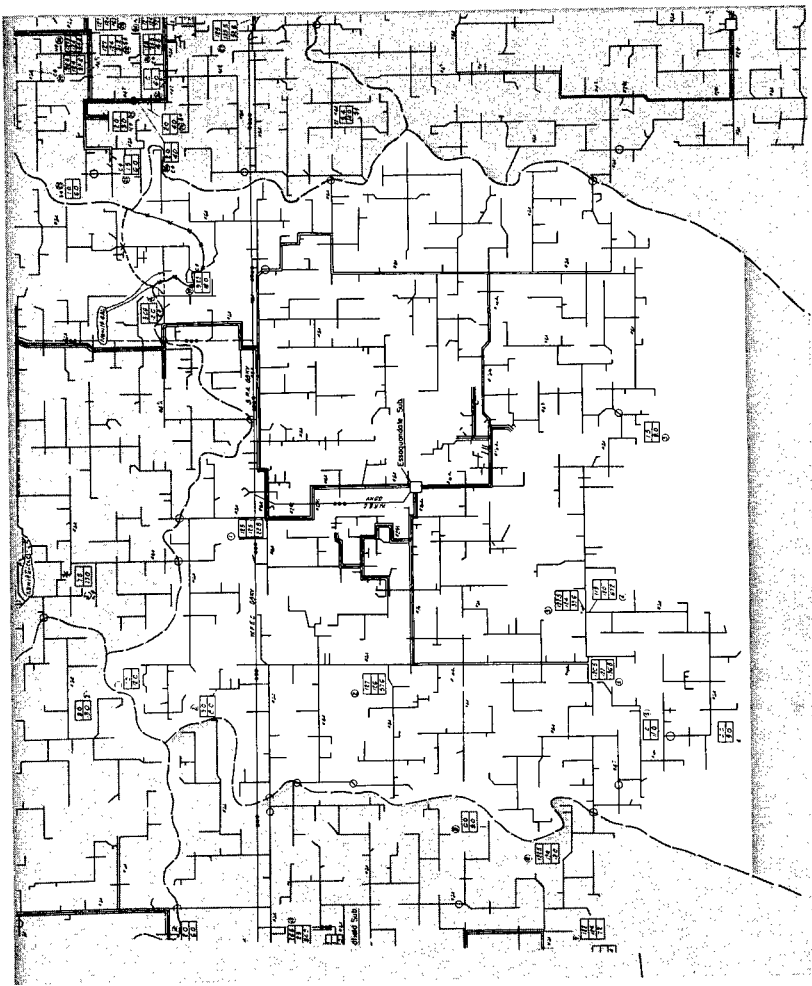
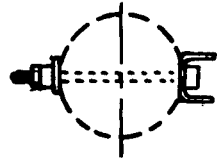

FIGURE I. Substation area of a rural electric system.



POLE TOP PIN ASSEMBLY

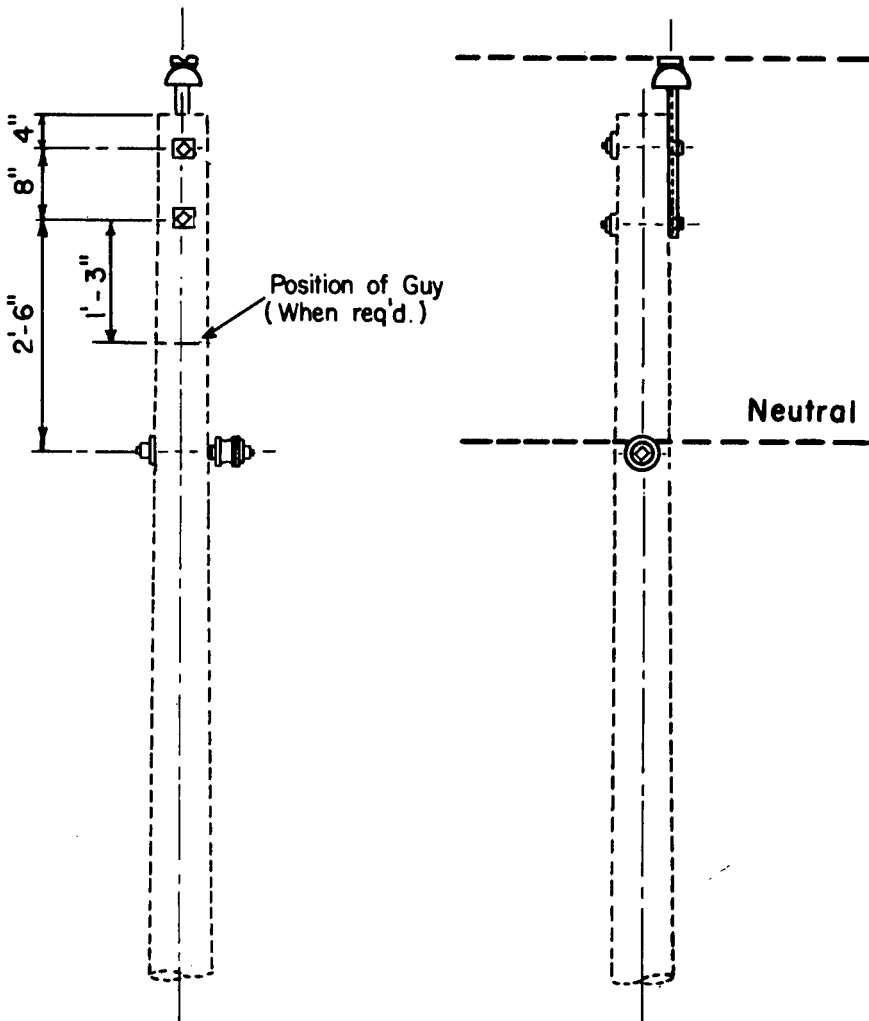

FIGURE II. Single-phase (7.2/12.5 kv) line supporting structure.

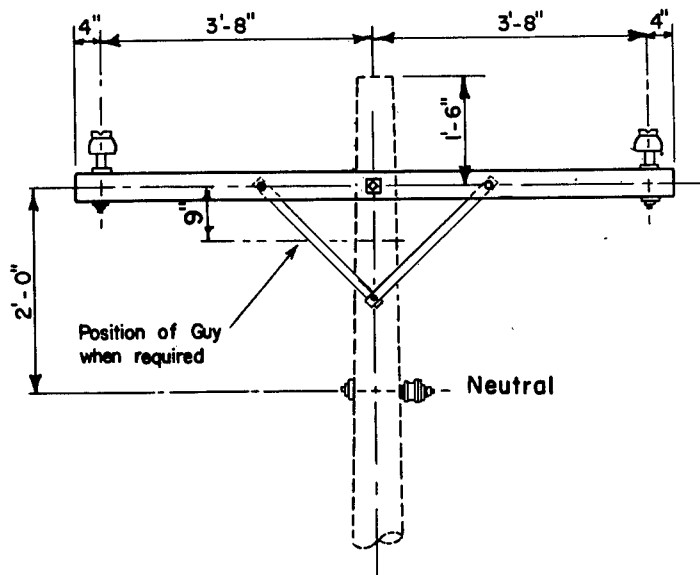
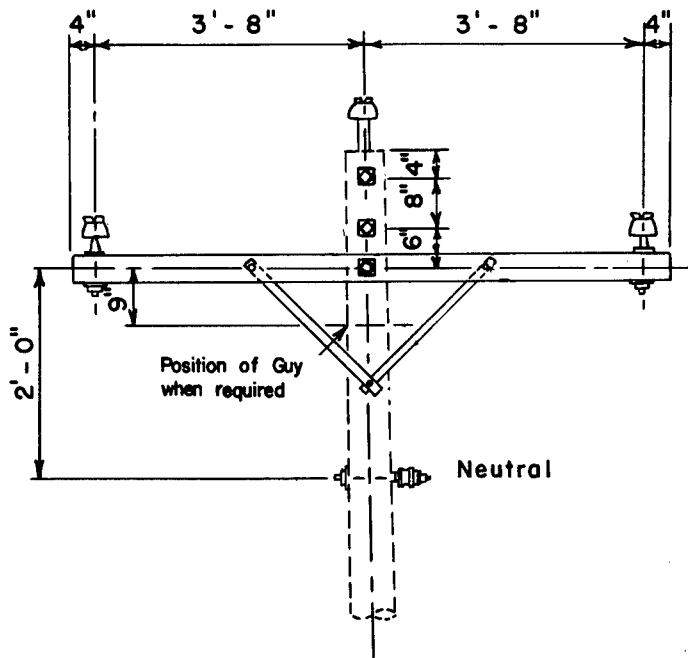

FIGURE III. Three-phase and two-phase (7.2/12.5 kv) line supporting structures.

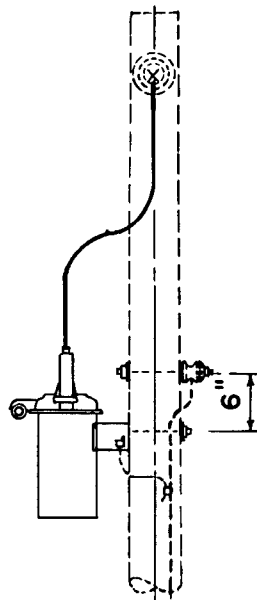
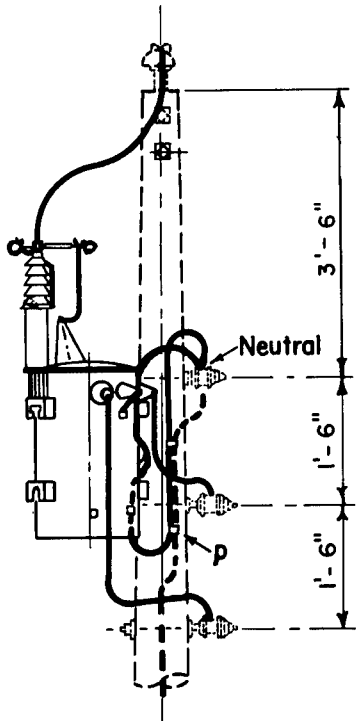
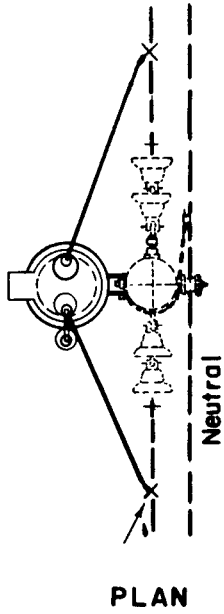
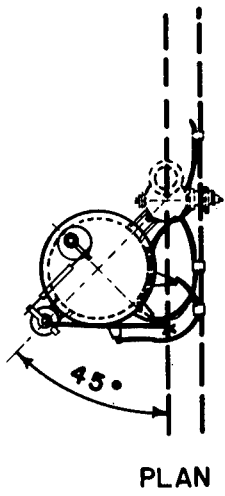
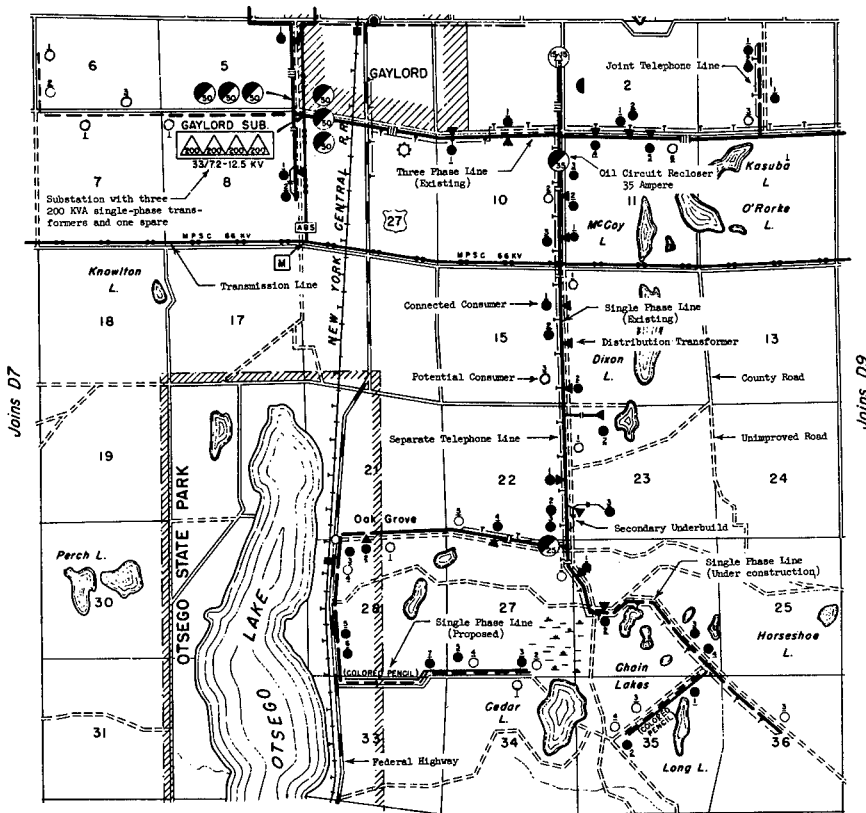

FIGURE IV. Single-phase transformer.

FIGURE V. Oil circuit recloser.

Joins C8



Joins EB

FIGURE VI. Detail map.

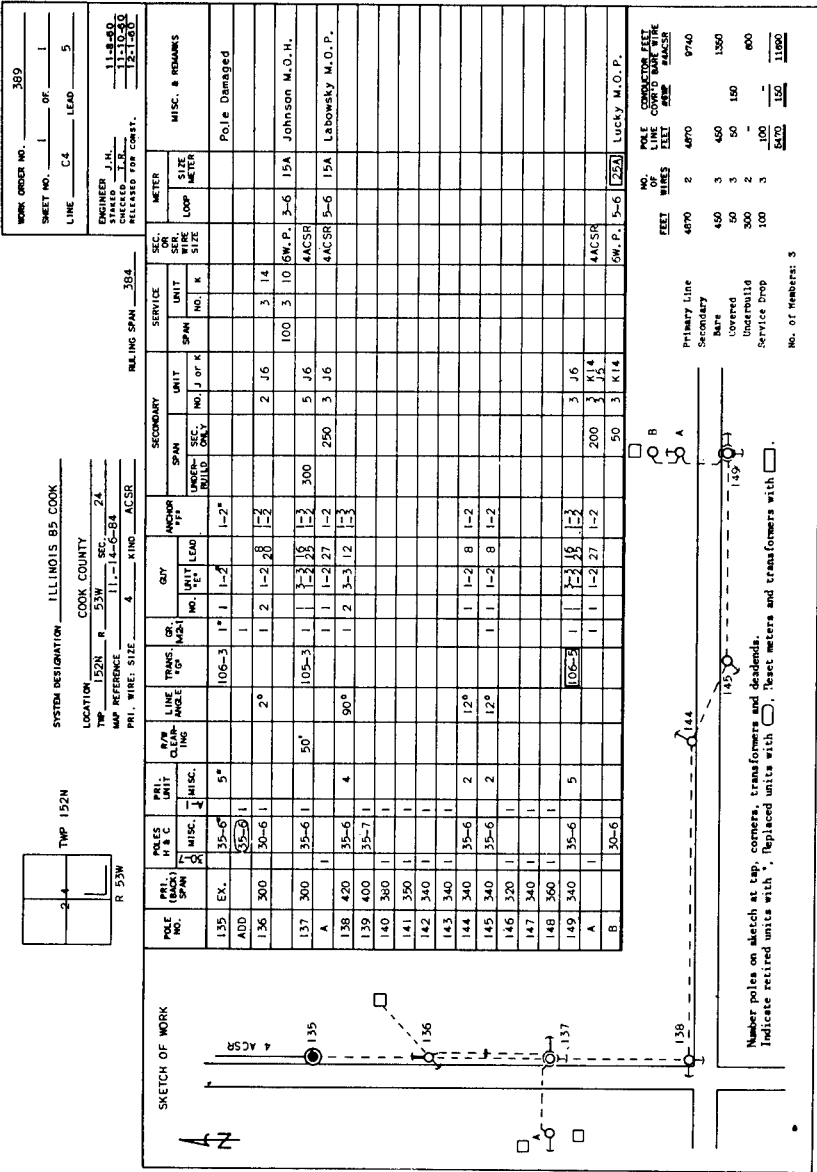

FIGURE VII. Staking sheet.

TABLE 10-A  
**No. 4 ACSR (7 Al/1 steel)**  
 Maximum tension=60 per cent of ultimate strength  
 Ruling span=425 feet

For 30-ft poles			For 35-ft poles		Uplift factor, feet	
At quarter point of span	At center of span	Span length, feet	At center of span	At quarter point of span		
Rise	5.2	205	9.5	9.7	2.0	
	4.9	251	9.0	9.4	2.6	
	4.4	272	8.5	8.9	3.3	
	4.0	295	8.0	8.5	3.6	
	3.6	317	7.5	8.1	4.3	
	3.1	335	7.0	7.6	4.8	
	2.7	354	6.5	7.2	5.6	
	2.3	372	6.0	6.8	6.0	
	1.9	390	5.5	6.4	6.1	
	1.5	409	5.0	6.0	7.3	
1.0	level 0	425	4.5	5.5	8.0	
0.6	0.5	440	4.0	5.1	8.7	
0.2	1.0	458	3.5	4.7	9.3	
Depression	0.2	474	3.0	4.3	9.6	
	0.6	489	2.5	3.9	10.8	
	1.0	503	2.0	3.5	11.0	
	1.4	518	1.5	3.1	11.6	
	1.9	532	1.0	2.6	12.3	
	2.3	547	0.5	2.2	12.8	
	2.7	4.5	560	0 level	1.8	13.7
	3.1	5.0	574	0.5	1.4	14.6
	3.5	5.5	588	1.0	1.0	15.0
	3.9	6.0	600	1.5	0.6	15.6
4.3	6.5	612	2.0	0.2	16.3	
4.7	7.0	626	2.5	0.2	17.3	
5.1	7.5	639	3.0	0.6	18.0	

NOTE: Use this table where estimated ruling span is between 350 and 500 ft.

TABLE 10-B  
**No. 4 ACSR (7 Al/1 steel)**  
 Maximum tension=60 per cent of ultimate strength  
 Ruling span=542 feet

For 30-ft poles			For 35-ft poles		Uplift factor, feet	
At quarter point of span	At center of span	Span length, feet	At center of span	At quarter point of span		
Rise	5.2	198	9.5	9.7	1.6	
	4.8	242	9.0	9.3	2.4	
	4.4	268	8.5	8.9	3.2	
	4.0	288	8.0	8.5	3.6	
	3.6	307	7.5	8.1	4.2	
	3.2	326	7.0	7.7	4.8	
	2.8	343	6.5	7.3	5.4	
	2.3	364	6.0	6.8	6.0	
	1.9	379	5.5	6.4	6.5	
	1.5	395	5.0	6.0	7.0	
1.1	level 0	411	4.5	5.6	7.6	
0.6	0.5	428	4.0	5.1	8.2	
0.2	1.0	442	3.5	4.7	9.0	
Depression	0.3	458	3.0	4.2	9.6	
	0.6	473	2.5	3.9	10.2	
	1.0	487	2.0	3.5	10.8	
	1.4	500	1.5	3.1	11.4	
	1.8	514	1.0	2.7	12.0	
	2.2	529	0.5	2.3	12.7	
	2.6	4.5	542	0 level	1.9	13.4
	3.0	5.0	554	0.5	1.5	14.0
	3.4	5.5	568	1.0	1.1	14.6
	3.8	6.0	580	1.5	0.7	15.3
4.3	6.5	592	2.0	0.2	16.0	
4.7	7.0	604	2.5	0.2	16.7	
5.1	7.5	616	3.0	0.6	17.3	
5.5	8.0	628	3.5	1.0	18.0	
5.9	8.5	640	4.0	1.4	18.7	
6.3	9.0	651	4.5	1.8	19.4	

NOTE: Use this table where estimated ruling span is between 501 and 570 ft.

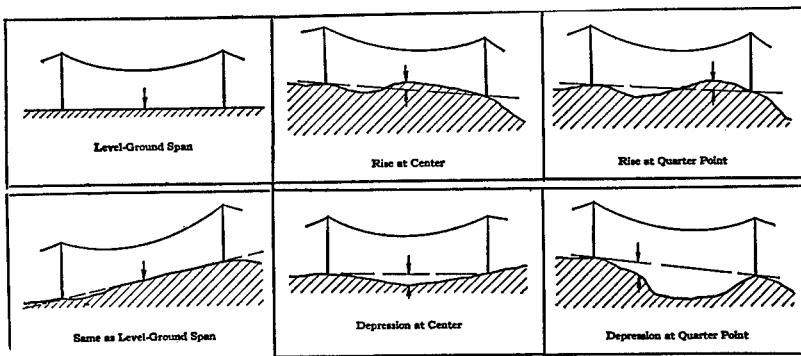

FIGURE VIII. Medium loading staking tables. (Reproduced by permission.)

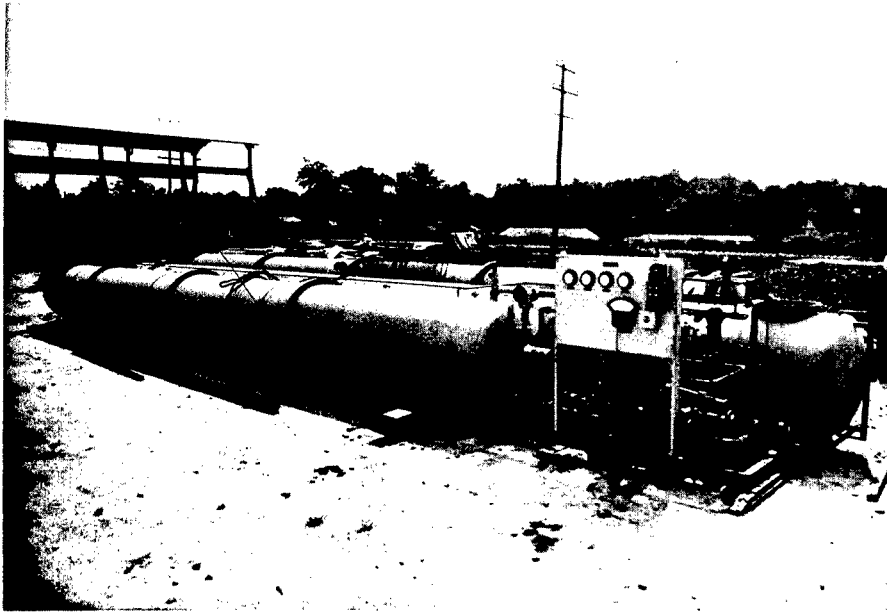

FIGURE IX. Prefabricated Wood Preserving Plant (package unit).

(Reproduced by permission)

Plant Size.....	10 feet x 55 feet
Cylinder Size.....	4 feet x 42 feet
Steam Requirements.....	1,380 pounds per hour
Water Requirements.....	5 gallons per minute
Electrical Power Requirements.....	25 horsepower
Approximate Cost.....	\$1,000 per foot of cylinder length
Estimated Installation Time.....	10 days
Training Time of Operating Personnel.....	1 to 3 weeks

This unit can be mounted on one or two flat bed truck trailers or on a railroad flat car and operated as a mobile unit. The only local requirements would be water and an electrical power connection.

# Experience of the Rural Electrification Administration: II—The REA Program and the Role of Rural Electric Cooperatives

J. B. McCURLEY

*Director, Electric Distribution Division*

D. H. COOPER

*Information Division, Rural Electrification Administration,  
U.S. Department of Agriculture, Washington, D.C.*

1. Thirty years ago, only one-tenth of the farms in the United States had the benefit of electricity generated at central stations. By 1962, however, almost all farms (97 percent) were electrified. This great change was stimulated by the Rural Electrification Administration (REA). This government agency financed and helped develop the rural electric systems that serve 54 percent of the nation's farms. It also represented the competitive stimulus which encouraged private power companies other than REA cooperatives to provide additional rural electrification. The purpose of this paper is to describe some of the methods used by REA to further rural electrification.

## Initial Stages of Rural Electrification

2. The notion that electricity generated at central stations could be distributed to every farm in the United States took hold of men's minds slowly. Theoretically, electric service came within the reach of

rural families with the discovery in the 1880's that the alternating-current voltage could be "stepped up" for transmission and then "stepped down" for utilization, so that electricity could be delivered economically over long distances.

3. Theory by itself, however, was not sufficient to electrify the rural areas. Financing on a large scale had to be provided. In the United States, farmers live on their land, and farmhouses are scattered across the countryside. In some ranching areas, houses are many miles apart. Rates to those consumers served were high. To obtain service many individual farmers paid a high price for construction of line extensions. Other farmers installed their own individual generating units which were generally very small and did little more than provide minimum lighting.

4. As early as 1923, some efforts were made to determine the potential uses of electricity on farms. Representative farm organizations, government agencies, power suppliers, equipment manufacturers and others formed a Committee on

the Relation of Electricity to Agriculture, known as the CREA. This group, financed largely by the electric companies, set up a rural-electrification demonstration at Red Wing, Minnesota, which showed how electricity could improve farm living.

5. This and similar demonstrations enabled farm families to become acquainted with, and encouraged them to use, electric lights, appliances, and equipment to do farm chores and provide household comforts. The careful records that were kept showed that as electric usage increased sharply, agricultural production rose and the overall operating expenses of the farmers dropped. Furthermore, electricity was saving human labor that could be applied to other activities. The whole level of life on the electrified farms was healthier and more productive.

6. There were other experiments in rural electrification. In a few places, usually on the outskirts of towns with municipally owned systems, small farmer-owned cooperatives were formed to distribute electric power. Except for extension of service to a few farms and other rural consumers along the urban fringes and main highways, little was accomplished toward satisfying the increasing demands for rural electrification. Rural electrification appeared unprofitable to private companies. In 1929, only 9.5 percent of the farms in the United States received central station service; by 1935 the figure was only 10.9 percent. The economic depression of the early 1930's further limited the electric companies' progress into farming areas.

#### **Establishment of REA**

7. In 1935, President Franklin D. Roosevelt created the Rural Electrifica-

tion Administration as an emergency relief program. In its initial form, the new agency found itself unable to accomplish much rural electrification. The executive order which set up REA anticipated that grants of money and other forms of outright subsidy would be used to relieve some of the unemployment which existed at that time. However, it was found that construction of electric lines required skilled workers who either were not on the relief rolls or not in the rural areas where lines were to be built. Another obstacle was the difficulty in finding some way to use the available Government funds effectively. A way therefore had to be found by which rural electrification could be accomplished. The first step was a decision to rely on a program of Government loans on favorable credit terms. The second step developed from the creation of consumer-owned, non-profit cooperatives as borrowers of REA funds.

8. In May of 1936, with passage of the Rural Electrification Act, the Congress of the United States established REA as a lending agency and authorized a 10-year electrification loan program. This lending authority was extended indefinitely in 1944. The Act empowered REA to make self-liquidating loans to companies, cooperatives, municipalities, and public power districts to finance the construction and operation of generating plants, transmission and distribution lines, and related facilities for the purpose of furnishing electric service to unserved persons in rural areas. In addition to making loans, REA would furnish technical assistance to its borrowers for engineering, management, accounting, public relations, power use, and legal matters. REA itself would not construct, own, or operate any electric facilities.

## REA Loans

9. REA loans are made for a maximum period of 35 years, and bear 2 percent interest. They are 100 percent loans, secured generally by first mortgages on the electric systems. REA advances funds on the loans only as the money is actually needed, and interest is due only on the money actually advanced. REA customarily grants a deferment on repayment of principal until the borrower can put its plant into service and have revenues coming in. The REA loan is repaid over the 35-year period out of revenues paid by individual consumers. REA also makes loans to its borrowers for relending by them to consumers for financing of electric wiring, plumbing, equipment, and appliances.

10. Use of member-owned cooperatives to provide nonprofit service in thinly populated and poor areas is a principal factor in the success of that part of rural electrification with which REA is associated. Other important features are the concept of area coverage, reduction of construction costs for rural lines, the availability of technical and other assistance, Government financing, and intensive education and promotion of consumers' use of power.

## Area Coverage

11. In developing full area coverage, REA borrowers build a "backbone" distribution system adequate for provision of service to everyone in the area who might eventually want service. Whether revenues will be sufficient to meet all costs and repay the REA loan is decided on the basis of the *entire system* of the borrower rather than on a particular line extension. Individual consumers do not

pay construction costs of individual line extensions.

## Reduction of Construction Costs

12. When REA engineers first faced the problem of rapid expansion of rural electrification in 1935, the cost of constructing lines was too high. Also, the requirements for lines in rural areas were quite different from in the cities. The long distance between consumers, who were spaced on the average about three to the mile, the hazard of lighting, wind-storm, and heavy icing conditions, and the interference of trees had to be considered.

13. As described in the companion paper by J. E. O'Brien, REA engineers developed new system designs and specifications. Light-weight, high-strength conductors permitted the use of lighter poles and much greater spacing between poles. Production-line techniques speeded system construction and reduced costs. These and other innovations brought down the cost of line construction. Development and use of standard specifications in purchasing materials and equipment, periodic inspection for preventive maintenance, improved inventory and warehousing methods, and better techniques for clearing trees and brush all helped to cut operating costs. To ensure economical construction and well-built systems, all construction was required to conform to REA standards and specifications. REA field engineers inspect the lines to assure that materials, design, and construction meet their standards. REA required that borrowers award construction contracts on the basis of sealed bids in order to secure the lowest prices. Many rural systems now have enough experience to build their lines with their

own construction crews. This is impractical for new cooperatives.

#### **Assistance on Organization, Management, and Technical Matters**

14. Originally, it was expected that the established electric companies would construct and operate rural systems. When it was seen that much rural electrification would have to be done by local cooperatives, organized by farmers and others with no experience with electricity or engineering, and very little in other businesses, REA realized that training and technical assistance would have to go along with construction loans. The pattern of REA assistance to the borrower (mainly, rural electric cooperatives) developed slowly and with some hesitancy. There was some apprehension that Government guidance in the formation of cooperatives might lead to governmental interference and control. Circumstances nevertheless compelled the fundamental policy step of providing help at virtually every stage of loan application, system construction, and operation. Where there was lack of experience with cooperatives or where local legal obstacles had to be overcome, in instances, REA found it necessary to help the prospective cooperative organize and incorporate.

15. Technical assistance to borrowers was necessary to safeguard the security of the REA loans. Guidance was provided through field personnel to work with applicants and borrowers, through staff specialists in Washington, D.C., and through publications. REA's electrical engineers, accountants, loan specialists, and management consultants are stationed at various points throughout the country convenient to borrowers' head-

quarters. These field representatives travel periodically to each borrower or applicant. The employees are carefully selected to assure exceptional professional skills and sympathetic understanding of the problems involved. Assistance is provided out of the REA offices in Washington, D.C., in such specialized fields as retail rates, negotiations for purchase of power at wholesale, safety programs, power use promotion, public relations, and legal consultation. Over the years an invaluable array of reports and bulletins has become available and may be obtained without cost. These range from statements of policy to detailed construction contracts, specifications, and drawings.

16. For all of the help and guidance that is available, REA borrowers are independent and separate entities. REA's long-standing basic policy reads as follows:

"In carrying out the loan programs and in protecting loan security, REA's activities in its relations with borrowers are limited to the requirements of each particular case and are based on the following considerations: That each borrower is an entirely independent corporate body, locally owned and controlled, subject to applicable State laws and responsible for the management of its own affairs, including proper and successful construction and operation of its system and the repayment of the REA loan. That the relationship between REA and an REA borrower is basically that of lender and borrower. That the underlying objective shall be to move as far and as fast as is feasible toward a situation in which every borrower possesses the internal strength and soundness to guarantee its permanent success as an independent local enterprise. That REA activities shall be carried on in such a way

as to promote the ability of borrowers to handle their own affairs effectively. That, as the borrowers gain in experience and maturity, thus becoming better able to meet their obligations to the Government and to rural people, REA's activities for the protection of loan security shall progressively diminish.

### **Promotion of Greater Use of Power by Consumers**

17. The electric industry is an industry of decreasing unit costs. Once a system is built and the consumer connected, a certain minimum charge offsets the fixed costs. Additional amounts of energy can be furnished at progressively reduced rates. Thus, within certain limits, the more electricity sold, the lower the price per kilowatt-hour and the stronger the financial position of the system becomes. It is to the advantage of an electric cooperative and the individual consumer to encourage and promote the use of greater amounts of electric energy for doing more farm and home chores.

18. When the rural cooperatives were building their first lines, some directors doubted that the average consumer could use as much as 40 kilowatt-hours. But it was soon found that while consumers start with moderate use—generally for a few lights, an iron, a radio, a refrigerator—the list of uses grows rapidly when the rural family sees how cheap electricity can be.

19. Over the years, the rural electric systems have built their lines section by section on an area coverage basis that brings service within the reach of every farm, every household, every potential consumer. This did not finish the job, of course. A great many families in poorer sections of the country did not feel they could afford electricity. Before REA, it

cost an average of \$70 for minimum wiring of a house and barn. This was beyond the reach of so many potential consumers that REA staff members met with representatives of the contracting industry and worked out a group-wiring plan which cut home-wiring costs to around \$55. A number of manufacturers cooperated with REA in offering for sale a lighting "package" which contained fixtures for an average-size farm house at about half the then prevailing price. Similar mass-purchase plans were applied to electric running-water systems and basic appliances. These plans helped the farmers and helped the new cooperatives. At the same time they opened up a vast new market for electric wiring, appliances, and equipment.

20. It was obvious that rural consumers unfamiliar with their new electric service would need some help in learning how to use it most effectively. In response to requests from the cooperatives, REA organized a traveling demonstration—a sort of road show where farm families could gather under the carnival tents and see electrical equipment in operation. Equipment manufacturers and appliance dealers cooperated by furnishing samples for the demonstrations—to show how electricity could be put to work cheaply and easily for cooking, refrigeration, pumping water, grinding, hoisting, and a variety of other farm chores and household uses.

21. A large number of rural systems added power-use advisers to their staffs as an extra service to members and also to help boost revenues from increasing consumption of electric power. These employees usually have experience as home economists or agricultural engineers. They arrange demonstrations for groups of members in different neighborhoods,

talk with individual consumers about their plans for house and farm wiring, and purchase of appliances, and help members arrange financing. In rural communities where consumer credit for such purchases is not readily available, the cooperative may borrow money from REA under section 5 of the Rural Electrification Act and relend it to individual members on favorable terms.

22. All of these efforts have helped build rural power consumption to levels far beyond early estimates. The rural electric systems have had to come back to REA and borrow additional funds to rebuild their lines to provide much greater capacity. Consumers have rewired their homes to take care of farm and household loads far heavier than anticipated. The former practice of restricting power for water heaters, and other loads which caused peaking of system demand is recognized as a mistake.

23. There are more than 400 different uses of electricity on American farms. Electric power is now the cheapest source of power available. A single kilowatt-hour of electricity, billed to the consumer at 2½ cents, will do any of the following:

- (a) Light a 100-watt bulb for reading or working for 10 hours;
- (b) pump 500 gallons of water from a well;
- (c) grind 400 pounds of feed—enough to feed 3 pigs for a month;
- (d) protect food by running a freezer for 12 hours;
- (e) milk a cow twice daily for 15 days;
- (f) hatch 5 chicks in an incubator;
- (g) run a TV set for 4 hours;

(h) operate a washing machine for 4 hours.

24. Farmers soon learned that a 1 horsepower motor can do as much work in an hour as an average man can do in a day. Usually the more repetitious the task and the more drudgery connected with it, the more easily an electric motor can be harnessed to take over.

25. Everybody gained from the tremendous increase in the use of electric power. For farmers, it meant greater production and improved quality of his products. For his family, it meant better health and safety, new comforts, and free time for other activities. For the rural community it meant more jobs and higher income to spend locally. For the electric appliance and equipment industry, it meant a whole new multimillion-dollar market. For the rural electric systems it meant unexpected margins that speeded up repayment of the REA loans.

### Rural Cooperatives

26. Most REA borrowers are rural electric cooperatives. There are about 930 of these nonprofit organizations which are active borrowers—that is, currently paying off their loans. Each is an independent, locally owned business enterprise, incorporated under laws of the state in which it operates. All consumers served by a cooperative are members of it. They share ownership of the system and have a voice in its operation. Each member has one vote in the election of the board of directors and in any other decisions brought up at the annual meeting of the organization. Bylaws adopted by the members set forth

the rights and responsibilities of members, procedures for electing directors, how the nonprofit character of the business is maintained, and other guarantees for a democratically run association.

27. Members of these rural electric cooperatives pay a membership fee of \$5 to \$10 which is usually returnable in case the member leaves the area. These cooperatives do not issue stock. Ownership equity of members accumulates from amounts of revenue in excess of the cost of service. The rate for electric energy is set high enough to cover the cost of providing service, plus an amount to repay the REA loan on schedule, plus a small margin to assure sufficient operating capital and reserves. Service is on a nonprofit basis; the bylaws in most cooperatives specify what shall be done with margins which remain after the payment of all expenses. Some organizations return the margins in the form of rate reductions, others as cash patronage refunds. Most of the rural electric cooperatives have written into their bylaws a provision for "capital credits."

28. Capital credits refunds work as follows. If a cooperative had a net margin of \$10,000 remaining after billing and collecting \$100,000 from consumers for service used, the refund rate would be 10 percent. A member who paid \$100 during the year for electricity billed to him would then have \$10 credited to his account out of the cooperative's \$10,000 net margin. Capital credits bear no interest. It is a way by which investment by the member-consumers gradually replaces the Government's investment, as the REA loans are paid off on schedule. When the board of directors determines that the net worth of the cooperative is high

enough to assure financial stability and sufficient operating cash, repayment of these capital credits is undertaken.

### **Dimensions of the REA Program**

29. The REA systems serve not only farms but nonfarm rural households, schools, churches, commercial establishments, and industrial plants of all kinds located in the countryside, often far from cities. REA has made loans to more than 1,000 electric distribution systems which serve 5 million consumers. Total loans amount to about \$4,600,000,000. Borrowers have now repaid more than \$1,000,000,000 in principal on their loans, plus about \$600,000,000 in interest payments. Only one borrower is currently in arrears on its scheduled payments. This record of REA repayment is a remarkable accomplishment.

30. Consumers served by REA borrowers have doubled their use of electric energy about every 10 years. Farm and residential consumers now average 375 kilowatt hours per month. Demand for ever-increasing amounts of power has made it necessary for a greater proportion of REA financing to be directed into cooperatively owned generating plants and transmission systems in recent years. Another principal accomplishment has been the steady lowering of both wholesale and retail prices of power. This has occurred against a background of generally rising prices in the American economy. Currently, the wholesale cost of power purchased by REA borrowers averages about two-thirds of a cent per kilowatt hour. The average retail price to the consumer on lines of REA borrowers is a little under 2½ cents per kwh.

31. Mistakes in the REA program have been easily offset by the overwhelming growth and success of rural electrification. Here was something that started out as a small effort to relieve unemployment during a period of acute economic depression. Much of the early effort was amateurish and experimental. It was freely predicted that the farmers could not pay for electric service, and that the REA borrowers would not be able to repay their Government loans. Both predictions were set aside. The REA pattern proved flexible enough to be used in all kinds of rural territory, under all kinds of conditions. With modification it has been used, for instance, in Puerto Rico with great success.<sup>1</sup> One lesson learned from a quarter century of REA experience is that the program must be standardized enough to keep down costs and assure high-quality performance, but also be flexible enough to fit the needs and capabilities of the people getting service. There are great differences from one geographic area to another in climate, in the type and level of the economy, in living habits and customs, and in technical development.

### A Pattern Which May Be Useful to Other Nations

32. The success achieved by REA offers a pattern which may be useful to nations where widespread rural electrification has not developed. Of particular significance is the role occupied by consumer-owned cooperatives. REA, as an agency of the Government, can provide financing and technical assistance for rural electrification, but continuing development and growth of this program must depend in the long run upon the initiative, ownership, and ultimate control exercised by the local people who benefit from the program.

33. The REA cooperative approach has brought many benefits into the lives of rural people. It has increased production and quality of farm products and at lower costs, introduced new or stimulated existing businesses or industries, brought better living conditions and increased income, been a means to better health and sanitation, and stimulated education and self-respect. Participation in cooperatives has developed community leaders, and has increased interest in local and national affairs.

### FOOTNOTE

<sup>1</sup> See the paper in this volume by Walton Seymour, *Typical Problems in the Development of Modern Power Supply in Less Developed Areas*.

### SELECTED REFERENCES

Childs, M., *The Farmer Takes a Hand*, Doubleday and Company, Inc., Garden City, N.Y. (1952).

*Rural Electric Fact Book*, National Rural Electric Cooperative Association, 2000 Florida Avenue, N.W., Washington 9, D.C.

*Rural Lines—USA*, Rural Electrification Administration, U.S. Department of Agriculture, Washington 25, D.C. (1960).

Brown, R. H., *Farm Electrification*, McGraw-Hill Book Company, Inc., New York, N.Y. (1956).

Schaenzer, J. P., *Rural Electrification*, The Bruce Publishing Company, Milwaukee, Wisconsin (1955).

Hienton, T. E., D. E. Wiant, O. A. Brown, *Electricity in Agricultural Engineering*, John Wiley & Sons, Inc., New York, Chapman and Hall Ltd., London. (1950).

Rixse, J. H. Jr., *Characteristics of Rural Electric Systems, Design, Construction and Operation in the United States*, Rural Electrification Administration, U.S. Department of Agriculture, Washington, D.C. (1960).

*The Year Book of Agriculture (1960)—Power to Produce*, The U.S. Department of Agriculture, Washington, D.C.

*Rural Electrification in Puerto Rico*, Commonwealth of Puerto Rico, Puerto Rico Water Resources Authority, San Juan, Puerto Rico, March (1962).

*Current Index of REA Bulletins—Electric Program*, Rural Electrification Administration, U.S. Department of Agriculture, Washington 25, D.C.

*Farm Electric Sales Handbook*. Publication No. 59-223, Farm Group Committees, Edison Electric Institute, 750 Third Avenue, New York 17, N.Y. (Rev. 1M-10-60).

*The Year Book of Agriculture (1962)*, chapter entitled "Invitation to 20th Century," The U.S. Department of Agriculture, Washington, D.C.

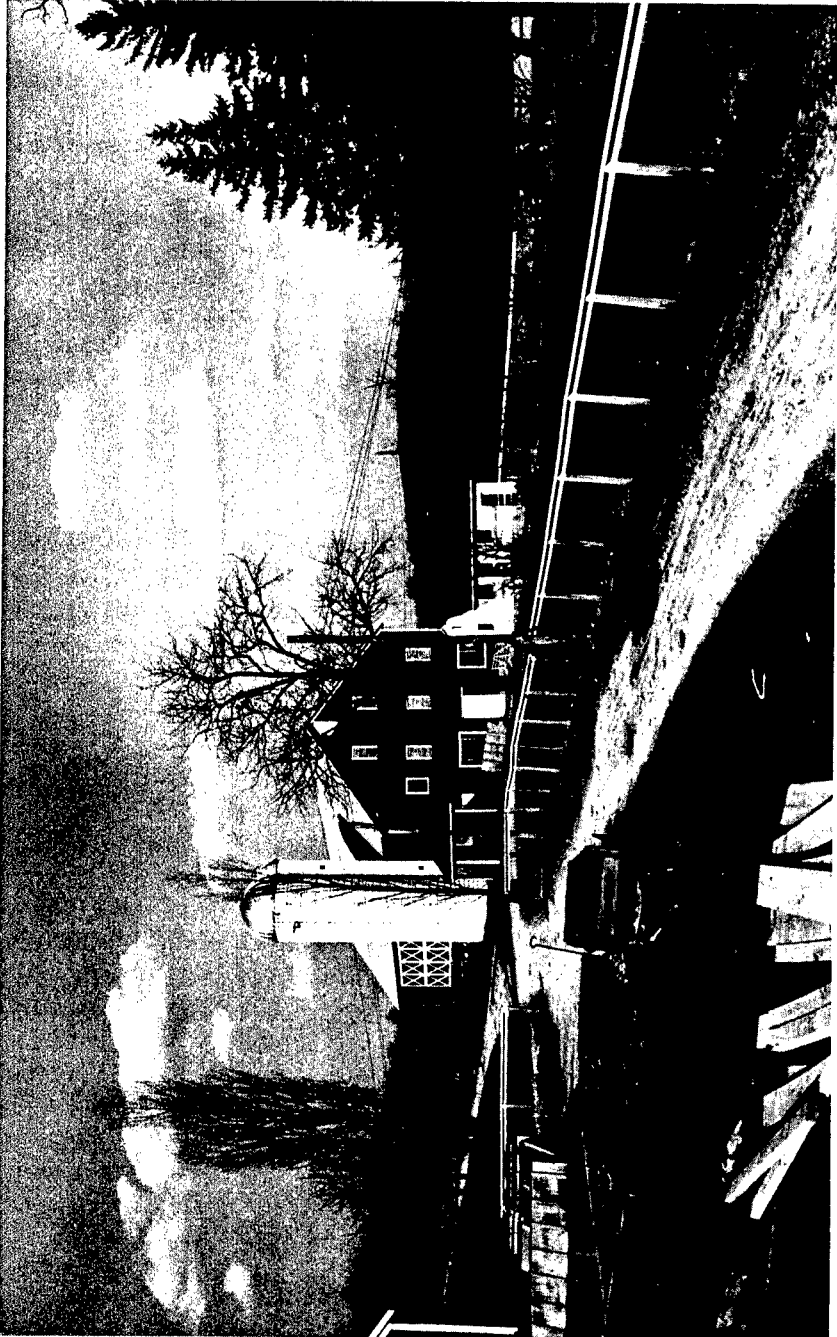

FIGURE I. Rural electrification makes farms more prosperous by increasing agricultural production and improving quality.



FIGURE II. Rural electric cooperatives use REA financing to bring the comforts and conveniences of electric service to rural homes.

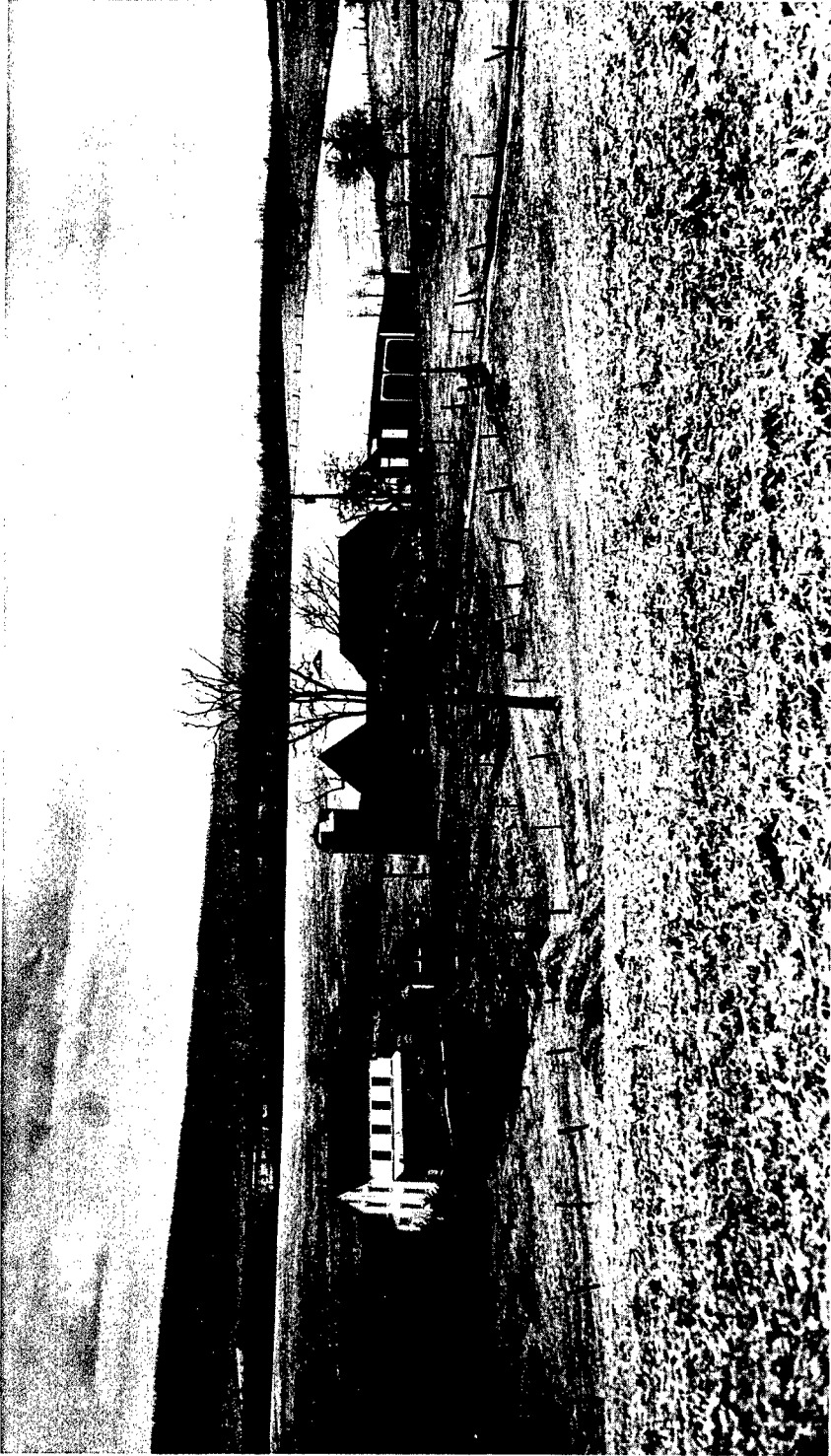

FIGURE III. Farms in the United States are widely scattered, so that consumers on REA-financed lines average only three to a mile of line.



FIGURE IV. An educational program helps new rural consumers use electric energy more effectively.



FIGURE V. An electric motor on the farm reduces the amount of manpower needed for heavy jobs.



FIGURE VI. Farm chores like grinding feed are done fast and easily with rural electrification.



FIGURE VII. Power for electric motors makes farming more efficient. Here a member of a rural electric cooperative sharpens tools.

# TVA's Experience With a Power Utilization Program for Rural Areas

G. O. WESSENAUER

*Manager of Power, Tennessee Valley Authority, Chattanooga, Tennessee*

1. Power engineers from most of the nations of the world have visited the Tennessee Valley Authority (TVA) to learn about the experiences TVA has had which may be of value to their countries. Most of them have been interested in the design, construction, and operation of power facilities. Only a few have been concerned with the problem of educating potential users in the ways in which electricity can contribute to a fuller and richer life for the individual.

2. In many countries a paramount need is for more generating capacity and for lines and substations to deliver electricity to villages and farms. Meeting this need is a challenging problem, particularly for nations whose major cities and major industries have far too little power. Nevertheless, the science of building and operating power-generation, transmission, and distribution facilities is well developed. But the art of showing people how to use electricity is not so well developed.

3. It is not enough to be able to produce electricity and to deliver it to towns and villages and farms. People must be prepared to use electricity when it becomes available to them. Demonstration and educational activities must accompany the construction of power-supply facilities.

Homes and community facilities must be wired adequately. Electric appliances designed with regard to local customs and within the financial reach of the customer must be available.

4. A primary purpose of an educational program for rural customers is to help them use electricity in a manner that is most beneficial to them with the least possible strain on their usually small incomes. But there is another important reason for these programs—one that sometimes is overlooked. Intensifying the use of electricity makes it possible to reduce unit costs. High consumption and a high rate of growth offer the best opportunities for low unit costs and low rates and a higher standard of living.

5. Some expenses of providing service to the electric customer either do not increase at all or do not increase proportionately with an increase in the amount of power the customer uses. For example, it costs no more to read a meter and bill a customer who uses 500 kilowatt hours a month than it does for one who uses 100 kilowatt hours. And the cost of labor, transportation, and material for operation and maintenance of distribution facilities often is little, if any, more for delivering the larger amount. Thus a portion of the expense for each kilowatt

hour delivered to the customer who is persuaded to use 500 kilowatt hours is only about one-fifth of that for the customer who uses 100 kilowatt hours.

6. In the Tennessee Valley region rural electrification was accomplished only with the most detailed step-by-step planning and with utmost patience. It required close cooperation among diverse groups, including the central government, state governments, and the governments in local communities or villages; among manufacturers of appliances; among banks and other private or public agencies which finance home wiring and the purchase of appliances; among schools and universities in training electrical development specialists; and among agricultural and health experts, particularly those who worked with agencies that already held the confidence of rural people.

7. It is hoped that a brief description of some of the things TVA did to develop the use of electricity among the farms and small towns of the area it serves may be helpful to others. It is recognized that there may be few direct parallels between the situation in the Tennessee Valley's rural areas and other areas in the world. But it is believed that many of the lessons learned from TVA's experience can have universal application.

8. When TVA began operations nearly 30 years ago there was little or no rural electrification in the nation. In the Tennessee Valley region barely 3 out of 100 farms had electricity; the few that were electrified were located on the outskirts of cities and towns. Rural and farm electrification simply did not exist and it was considered by many thoughtful persons to be impracticable. Cash incomes were very low and most utility managers felt that the farmers could not

afford to buy electricity, nor the appliances to use it.

9. TVA tackled the job of rural electrification from a number of different directions, changing tactics as conditions changed. TVA's approach was inventive rather than traditional. TVA followed a policy in all of its activities of enlisting the aid of local groups and gradually shifting to their shoulders as much responsibility as possible. Because rural electrification was new and largely untried in the United States, TVA found it desirable in the early years to assume the major share of the responsibility for getting the job started in the Tennessee Valley region.

10. In summary, these are the important things that TVA did: (a) provided a supply of low-cost power through multiple-purpose dams built for flood control, navigation, and power; (b) adopted electric-rate schedules that were unusually low and designed to encourage abundant use of electricity by the small customer, including those whose incomes were low; (c) made marketing surveys of selected rural areas and signed up customers; (d) designed rural distribution lines that could be constructed at the lowest possible cost; (e) established an agency to finance the purchase of electric appliances by the customers; (f) encouraged manufacturers to provide low-cost appliances; (g) built rural lines and operated rural systems to demonstrate what might be accomplished. As TVA demonstrations proved successful, rural systems were sold to the local people with TVA providing the financing if needed; (h) provided electrical development specialists to work with individuals and with groups, showing them what they should do to prepare for electric service and how electrical appliances

could be used in their homes and on their farms.

11. In the formative years, TVA realized that regional economic improvement would best be achieved through a process of voluntary agreement among the people. If this endeavor was to achieve its hoped-for success, effective democracy at the "grass roots" would be required. It would have to be the result of programs launched by local decisions and given strong support, leadership, and participation.

12. TVA enlisted the aid of every agency that could help the program become a reality: the Rural Electrification Administration, the Federal Government's Departments of Agriculture, Commerce, and Interior; State agencies, extension services, county agents, and education and agriculture departments; the local agencies distributing TVA power; banks, schools, colleges, and universities; newspapers and radio stations; appliance manufacturers and appliance dealers; and local clubs and community associations.

13. The people of the Valley were drawn into the program as participants from the very start, giving them, as David E. Lilienthal, one of three men appointed to the first TVA Board of Directors, said, "the fullest opportunity for the release of the great reservoir of human talents and energies."

14. Some said that the power produced at TVA's dams, regardless of its low cost, would never be used by the Valley's people, because they had no foreseeable way of using it. TVA's answer was a broad program of education to promote power utilization.

15. The power utilization thesis was this: With an abundant supply of low-cost electricity readily available, the

farmer must learn to use this servant for the betterment of the farm family. New means of financing would be required to help him purchase electric equipment. Every reasonable idea which would place electricity in the hands of the farmer became an established program of power utilization.

16. First, the Valley people needed electric appliances. Few could afford to purchase even one of the essential pieces of equipment. To help solve this problem, a new Federal agency was established. Incorporated in 1934 with the TVA directors as the governing body and called the Electric Home and Farm Authority (EHFA), its purpose was to finance the area people's purchases of a basic model of water heater, range, and refrigerator. The EHFA secured a million dollar loan from the U.S. Treasury to begin operations.

17. Designs for low-cost appliances to be financed by EHFA were submitted by the nation's appliance manufacturers. Acceptable appliances were stamped "TVA Approved." To gain approval, the appliance had to be quality-built and made to sell for about a fourth less than the usual price. The approved appliances were offered through the manufacturers' normal commercial outlets with financing by EHFA. The refrigerator could be paid for in 3 years, with interest between 5 and 6 percent. By purchasing two or more appliances, payments could be spread over a 4-year period.

18. The effect of EHFA activities was to reduce the cost of borrowing to buy an appliance, to lengthen maturities so that smaller monthly payments were required, and to extend to a wider area these financial services, in contrast to commercial companies whose areas were much narrower. EHFA was financially

a self-sustaining organization, meeting all obligations from the return of interest payments on loans.

19. The mechanics of the financing program were simple. An appliance purchaser signed appropriate papers which the dealer transmitted to EHFA for cash payment. The purchaser paid an additional sum on his monthly electric bill sufficient to pay for the appliance with interest. In turn, his local electric system turned over these collections to EHFA.

20. The appliance-financing program began in Tupelo, Mississippi, the first town to receive TVA electricity, and was rapidly extended to other cities, including those which were served by privately owned utilities. With appropriate publicity due the event, a showroom of electric appliances was opened. The people came, saw, and purchased. Not only did they purchase the basic "TVA Approved" models, but other more expensive designs experienced a great sales increase.

21. Later, the EHFA borrowed additional money from banks, approved other appliance designs, and opened other electric showrooms. It continued operations for about 7 years. By the time the economy had improved from the depression of the thirties, appliances were available at reasonable cost, and financing programs based on the EHFA example were put into effect by commercial financing institutions. When EHFA was discontinued, the Government's investment was returned to the U.S. Treasury plus a substantial surplus.

22. To make rural coverage a success, TVA encouraged the formation of rural cooperatives—organizations of farmers and other citizens who would undertake the construction and operation of distribution facilities to supply to its mem-

bers retail power purchased wholesale from TVA. In the early years, it was necessary in some instances for TVA to build and operate the distribution systems, serving the customers directly at retail until the operations proved feasible and cooperatives could be organized to take them over.

23. It was necessary to secure the active support of the local citizens—those who knew the traits and customs of the people. In group meetings, local people volunteered to get in touch with everyone living in an assigned area. Each volunteer secured signed applications for electric service from the families in his section, together with a monetary deposit if required, and a right-of-way easement which would allow the power system to construct the necessary distribution lines.

24. Self-help was encouraged. In some instances, farmers cut poles from trees on their own property and had them treated with preservative. They dug holes and set the poles themselves in order to speed the project and reduce their minimum-bill requirements.

25. During the period between survey and actual line construction, TVA and members of the rural electric cooperatives held many community meetings with representatives of agencies engaged in agricultural activities. Always, the subject discussed was preparation for the coming of electricity. Portable generators and demonstration equipment were transported across streams into the backwoods areas, into those coves and valleys and plateaus and lowlands which had never known electricity. People attending the meetings saw their churches, schools, or stores lighted electrically for the first time. Motion pictures were shown, appliance demonstrations given, home-wiring and lighting plans were drawn.

26. In the early years—from 1933 until the beginning of World War II—TVA worked intimately with the local people as they helped villages, small towns, and farmers in selected rural areas to receive electric service. During the war, it was necessary to curtail the construction of rural lines to conserve materials and manpower; demonstration activities were discontinued because appliances were not available.

27. With the end of the war, construction materials and appliances again became available. To meet the pent-up demands of rural people and to fulfill the engineering plans that the local electric systems had held in abeyance, TVA and the distributors adopted the concept of areawide coverage, in which it was the purpose to provide service to every home and every farm and not just the homes and farms of selected areas which were considered to present the best prospects for an immediate and economical market for electricity.

28. Areawide coverage became a community action. By incorporating an entire county, or several counties, into a single working plan, considerable interest, enthusiasm, and a sense of sharing something new and wonderful prevailed which TVA could not insure alone. In retrospect it seems quite possible that the area-coverage concept, had it been used in the beginning rather than the selective process, would have resulted in achieving rural electrification more quickly and efficiently.

29. Once low-cost electricity and appliances were available, and area coverage had been accomplished, TVA, cooperating with other agencies and groups, concentrated its efforts on educating and informing the Valley people about how to make best use of this new tool

which had been placed in their hands to save work, increase production, and improve sanitation.

30. In the field of vocational education, TVA prepared a training manual which was used to teach the new methods of farming with electricity. At one time, many thousands of young men, all of them returning veterans of World War II, were participating in a training program specifically aimed at assisting them to adjust to electrical living on their farms.

31. TVA's agricultural engineers taught special courses in schools, workshops, and informal gatherings on farm uses of electricity. They designed and built wiring panels which the locally owned electric systems placed in the high schools. They held classes on farmshop practices for state vocational agricultural teachers. They designed and built trailers, which contained demonstration equipment on farmshops, poultry raising, feed processing, farm motors, farm wiring, and farm-water systems. This caravan of demonstration equipment, making its way to meetings and taking its teaching to the people, became a common sight along the area's highways and backroads.

32. The water system workshop was especially beneficial. As recently as 1953, three out of four farms in the Tennessee Valley did not have running water under pressure. This situation presented a challenge to TVA and the local systems distributing TVA power not unlike the challenge of 1933 when only 3 percent of the farms were electrified. Few things available in a lifetime could add more to the well-being of a farm family than an adequate supply of clean pure water from protected wells, piped into the house under pressure. Water systems

had been talked about and promoted for some time with moderate success. But a more dynamic, effective method of convincing the farmer of the advantages of running water in the home and on the farm was needed.

33. State health officials were eager to work with TVA in developing a useful program, for they realized that rural water supplies were becoming increasingly contaminated and affecting the health of the rural people. A simple post card survey got the program under way. Those local electric systems entering the program mailed the post card questionnaire to each of their rural consumers, asking specifically about the farm's water supply, pledging help in giving advice, and asking if the home would like a visit by a specialist in water sanitation. The results were gratifying. A rural electric cooperative in Mississippi mailed 4,000 cards to its rural customers, received 2,500 in return; 800 of these requested visits.

34. A great deal of the responsibility for determining the extent to which the farm home will be modernized rests with the farm wife. To help her, TVA has worked with state agricultural agencies and local home-demonstration clubs in assisting thousands of farm women in planning for the most advantageous use of water under pressure in the home.

35. TVA specialists worked with youth organizations interested primarily in better farming and better living. TVA's specialists, power-distributors' personnel, and equipment manufacturers combined to show them a possible way.

36. The variety of power-utilization programs did not come about all at once; they grew out of the basic idea of assistance, education, and information as the needs and opportunities arose.

37. For example, as a result of a survey, TVA found that the teaching of the electrical phase of homemaking—the use of stoves, washing machines, irons, vacuum cleaners, and other home appliances—in high schools and colleges was at a very low level. Inadequate teacher training and lack of modern electrical equipment were at fault. Once aware of the condition, interested agencies took the initiative in finding a solution. A program evolved whereby new appliances were made available to the schools. In many cases, local parent-teacher organizations and school boards became the forces for action. Appliance manufacturers permitted schools to purchase appliances at exceptionally low cost and to replace them periodically at no additional cost as new models came out.

38. TVA also assisted the universities in improving courses of study in home economics, and in setting up electrical-appliance "laboratories." TVA and the universities established a cooperative training program for women students studying home economics and for men students studying agricultural engineering. The students alternated between on-the-job work periods in the field and study periods at their universities. This cooperative program established a continuous line of expanding knowledge and supplied many qualified persons for employment in the area. TVA continues to employ agricultural engineering students from the nation's colleges and universities.

39. TVA, cooperating with appropriate agencies and individuals, has touched nearly every usage of electricity. It has carried on home-wiring programs, aimed at acquainting electrical contractors, architects, builders, electricians, and others interested in home improvements with

the requirements for adequate wiring in the modern home. It has held home-laundry workshops and home-lighting workshops.

40. TVA's engineers have provided help in the design of school lighting and school kitchens. They have assisted many communities by designing the installation of new, adequate street-lighting. They have worked with the power distributors in helping hundreds of industrial customers relight and rewire their plants for greater and more efficient production or for conversion from one type of production to another. Commercial establishments were assisted in the use of electricity for better lighting, air conditioning, and heating. Thus the industrial and commercial side of power utilization benefitted the people and their community.

41. Only last year TVA held a power-utilization training institute for power-distributor personnel. The object was to better qualify these people in the areas of lighting, commercial and industrial activities, publicity, advertising, and public relations work, and agricultural engineering, so that they, in turn, might better serve their customers, the people of the Valley.

42. Another long-range development just getting under way is the "electro-farm" program. It is a joint activity of personnel of governmental agencies engaged in agricultural activities, the distributors of TVA power, and TVA. The

farmer and his family are encouraged to establish goals for the development of their farm and home, including methods of mechanizing farm materials handling. Electrically operated milking machines, hay dryers, milk coolers, silo unloaders, chick brooders, and feed-processing equipment are some of the devices which help to reduce the farmer's burden and increase his income.

43. Advice and assistance are given by specialists of the cooperating agencies. An electro-farmer is shown how electricity can help achieve his stated goals, and he agrees to carry out the planned program as his budget permits. By making this program available to every farmer in the area, electricity will be used to raise farm-income levels and to make living on the farm more agreeable, convenient, and enjoyable.

44. TVA's coordinated power-utilization program has been effective in making electricity a widely used working tool of modern agriculture. As the average use of electricity has grown the unit costs have decreased despite rising costs of materials and labor, making it possible to supply power to the people of the region at lower costs per kilowatt-hour. In turn, this has widened the opportunity for still greater use in more and more of the farming operations. And in all of the power-use activities, the essential ingredients were cooperation, persuasion, encouragement, and the incentives engendered by active participation of the people.

# Some Problems in Initiating Power Supply in Less Developed Areas Based on Case Histories

FRANKLIN J. LEERBURGER  
*Consulting Engineer, New York City*

## Introductory Comments

1. The introduction of a power supply in a less developed area and consideration of some problems in accomplishing this end must not be viewed as a generalized situation. The types and varieties of social and economic factors are not uniform. The social, economic, and political circumstances favorable to successful introduction of a supply of power must be taken into account as inseparably related to the technical considerations. The emphasis of this paper will be concentrated on the economic and technical problems, leaving to other writers and perhaps other forums discussions of the ineluctable factors of the political and social climates.

2. The less developed areas are largely rural, with scattered urban centers. The benefits of a power supply in the early stages of development cannot be realized merely by making a source of power available. The development of knowledge of the benefits and methods of utilizing power are an essential concomitant of any scheme of introducing power.

3. The objectives of electrification in less developed countries are less sophisticated than in areas of advanced indus-

trialization. Generally, electrification is looked upon as a means of making possible: (a) Widespread handicraft production to be converted as rapidly as possible to simple industrial production; (b) Processing of forest and of agricultural products; (c) Introduction of simple schools of mechanic arts and of equipment and machinery repairs; (d) Simple water supply for potable and irrigation purposes; (e) Servicing the communication system and the increasing educational facilities; (f) The introduction of power supply for medical services and hospitals; (g) The introduction, where practical, of home lighting and appliances and comfort cooling.

4. A power supply is composed of production and transmission facilities on the one hand and utilization system, apparatus, and appliances on the other. There is a desire to "telescope into a few years the progress that took us (the people of the United States) generations to accomplish." (1) Retrospective observations of some less developed areas and of a transitional one, Greece, and of the United States suggest to an engineer that the favorable climate is created when the need

for education, skills, health, effective social organization, and efficient and just government are recognized and pursued. "All too frequently diagnosis of underdevelopment and prescriptions for overcoming it proceed on the assumption that capital and technical knowledge are the only missing elements."(2)

### General Outline of Discussion

5. There appear to be two general lines which electrification in less developed areas has followed: one is the relatively large-scale supply to meet the demands of the major city, capital, port, or projected industrial area, without much consideration for the rest of the country; the other is installation of numerous small scattered plants throughout the country. Interconnected plants, grid systems and pooled operations have generally not been introduced, although there has usually been some thought given to future grid development or integration when economic feasibility permits it.

6. Major arguments of this paper are:

(a) In introducing a supply, easy availability and wide distribution are more important than low price or rates.

(b) In developing a power system, thoughtful application of capital expenditures should prevent the building of "outsized" plants on the fallacious notion that an overabundant supply, with low rates made possible by foreign aid, would automatically bring new industries and heavy power use. The cost of electricity is generally but a small portion of total cost of producing industrial goods.

(c) In maximizing benefits, small-scale package diesel units make for

flexible adaptation to changing circumstances and requirements.

(d) In expanding a power supply, once initial installations have been made, growth should be based on adequate revenues from users of the service and on borrowings justified by such revenues.

7. In 60 years of transition to electrification in the United States, although many lessons have been learned, some of the basic factors may not find counterparts in present less developed areas. The North American experience cannot, however, be overlooked.

8. In discussing costs or rates in terms of U.S. currency, it must be pointed out that conversion of local currency values to equivalents in U.S. currency is artificial. The official exchange rates bear little relationship to any ratio of purchasing powers or values; nevertheless, the rates for service have been converted for comparisons and conclusions recognizing the limitations inherently contained in such data.

9. The organization of this paper is such that six less developed areas will be discussed in a group, followed by a cursory review of the Greek power picture, as illustrative of a country in transition and, finally, certain facts will be presented with respect to development of the United States, by way of contrast.

10. Table 1 has been designed to compare 1959 or 1960 data bearing on the level of development of electrification in six less developed areas, in Greece, and in the United States. The 1960 population and density per square kilometer are set forth in the first two columns of figures. The installed capacity of all generating equipment in terms of nameplate rating is stated for each country in the third column of figures. The fourth column

TABLE I. Installed generating capacities and production of electric energy for public supply in six less developed areas—compared with corresponding statistical data for Greece and for the United States, year 1959 or 1960

	Population—1960		Installed capacity (1,000 kw.)	Annual production (million kwh.)	Per capita		Per capita Rates As percentages of United States		Capacity factor (%)
	Millions	Density per sq. km.			Capacity (Kw.)	Production (Kwh.)	Capacity (%)	Production (%)	
Less developed areas:									
Laos.....	1.8	8	3.4	5.0	0.0019	2.8	0.20	0.07	17
Mali.....	4.1	3	*12.	*21.7	.0029	5.2	.31	.12	21
Nepal.....	9.2	65	6.9	9.7	.0008	1.1	.09	.03	16
Somalia.....	2.0	3	12.9	16.3	.0064	8.1	.68	.19	14
Uganda.....	6.7	27	131.9	396.5	.0197	59.2	2.10	1.40	**34
Vietnam—South.....	14.1	83	98.0	280.0	.0070	20.0	.75	.47	33
Greece.....	8.3	65	593.0	2,207.0	.071	266.0	7.6	6.3	42
United States:									
Total electric utility industry.....	178.5	23	167,500.0	752,900.0	.938	4,218.0	100.00	100.00	51
Total electric utility industry and industrial plants.....			185,000.0	840,000.0					52

\*Estimated.

\*\*About half of the production and of the capacity are devoted to supplying a high load-factor contract with Kenya.

TABLE 2. Comparative costs of diesel fuel electricity to classes of consumers in six less developed areas—compared with corresponding statistical data for Greece and for the United States

[U.S. cents]

	Oil cost per U.S. gallon	Per kwh.		
		Domestic and general	Power	Unclassified
Less developed areas:				
Laos.....	41	32.0	23.0	.....
Mali.....	58			5 to 18
Nepal.....	33 to 50	3.5	1.4	.....
Somalia.....	37 to 50	16.8	15.4	.....
Uganda.....	(*)	4 to 14	.3	.....
Vietnam-South.....	18			.....
Saigon.....				9.6
Small towns.....				24.0
Greece.....	11 to 15			3.0
United States.....	9 to 11	2.47	.96	1.9

\* Data not available.

of figures relates to annual production of electric energy, and the fifth and sixth columns are, respectively, the quotients obtained by dividing the figures in the third and fourth columns by the population data in the first column. The seventh and eighth columns are related to U.S. data referred to as standards for comparison. The last column of figures captioned "Capacity Factor—percent" was developed by dividing the annual production figures by the corresponding installed capacity multiplied by 8,760 hours per year and converting into percentages the resulting quotients.

### Case Histories

11. *Laos.* This is a landlocked area of two million inhabitants with no railroads, few highways, and limited radio-communication system. There is a small telephone network. Excepting for a

small amount of wood for fuel, there is no indigenous fuel supply. Coal has been discovered, but tentative conclusions suggest that its exploitation is not feasible. There are a few hydroelectric sites which are relatively small and not easily capable of development. If the Mekong River should be developed for all the countries along its banks, Laos, of course, would be a significant beneficiary. Vientiane, the capital, has the principal power supply in the form of diesel-engine generation and a few towns have small units aggregating very little capacity. Diesel fuel is costly and must travel over a complicated transportation pattern from Bangkok by rail to the railhead in Thailand at Oudorn, at which point the oil drums are transferred to trucks and taken to the banks of the Mekong River, where another transfer is made to boats and still another transfer made on the Laos side. The price of diesel fuel in 1957 approxi-

mated 41 cents per gallon at the official rate of exchange. This price was government controlled. From the foregoing, it is evident that only small and scattered diesel units could be installed. Cost of electricity would be relatively high, but in its very availability the economy should benefit by bringing more of the public into the market.

12. Table 1 shows installed capacity of .0019 kilowatt, or about 2 watts per capita with annual production of about 2.8 kilowatt hours per capita. The limited degree to which the installed capacity is actually used is indicated by the low capacity factor of 17 percent. The degree of underdevelopment measured in terms of per capita production is slightly more than 1 percent of a transitional area represented by Greece and .07 percent of an advanced economy, such as that of the United States. Rates for electric service are high, ranging from an average of 23 cents for power to 32 cents per kwh for domestic service, although it is not believed that the low utilization of existing facilities can be clearly attributed to high unit price. There is no systematic accounting and no knowledge of the extent to which rates are compensatory.

13. *Mali*. This country, also landlocked, was once a part of the French Sudan and intimately coupled to Senegal by strong economic ties. Until recently, there was a good railroad connecting Bamako, the capital, with the sea at Dakar, in Senegal. Political considerations brought about the interruption of this railroad and isolated Mali from economical bulk-transportation routes to the outside world. A large and modern airport permits adequate air service between France and Mali and the surrounding countries of Africa. There are two railroads, one from Abidjan, Ivory Coast,

and the other from Conakry, Guinea, to inland points about 400 miles from the sea. From two railheads to Bamako, a distance of about 300 miles, there are highways capable of supporting trailer-truck loads. The population of about four million is widely scattered and the few urban areas are not heavily populated.

14. The Niger River is relied upon for some seasonal transportation of bulk loads and for irrigation. The extremely wide range of discharge rates of the river has not encouraged its exploitation for power. Studies were made of the possibilities of limited hydroelectric development coupled to irrigation operations. The capital, Bamako, has in operation a modern diesel-electric station of limited size, but the fuel supply is difficult to maintain now that the railroad to Dakar has been severed.

15. Table 1 shows the capacity and annual production in Mali as 12,000 kw and 22 million kwh, respectively. Not only are the per capita figures for capacity and consumption low, but the use to which that capacity has been put is low based on the capacity factor shown in the last column. Considering the relatively high cost of oil, 58 cents per gallon, the rates of 5 to 18 cents per kwh are not excessive. It is not known whether the rates are compensatory.

16. The vigorous attempt now being made to utilize the waters of the Niger River near Bamako for a small run-of-river generating station will involve heavy capital costs because of geography and difficulty of transportation. Such a station would, however, obviate the country's complete dependence on imported fuel and would conserve foreign exchange. Electrification away from the capital would not be improved and there would still be a need for installing well-

scattered but small-package generating units powered by diesel engines. The availability of some limited power facilities, when and where needed, would be more important to the population of four million in encouraging economic progress than would be the undoubtedly high cost of such electric service.

17. *Nepal.* Turning next to Nepal, we find an old civilization widely removed from Western thoughts and with a very great gap to be bridged between its economic development and that of many other nations. Agricultural practices and the centuries-old terraces attest to the adjustment of the people to the difficulties of producing food under adverse circumstances.

18. In Nepal, communications are limited, and a net utilizing scattered radio transmitters and receivers powered by small engine-driven electric generators is now being installed. There are no railroads (except a short spur of the Indian rail system adjacent to Raxaul) and few highways. Some limited air service, however, has become available. All fossil fuels must be imported, but there is a large untapped amount of hydroelectric potential in the great rivers which rise in the Himalayas. Many hydro-projects are under study, all of which require large amounts of capital. Some industries have been established, such as spinning and weaving, ceramics, furniture making, silversmithing, automobile repairing, and these will require training of additional workers and the availability of small blocks of electric power in some areas.

19. The potential for large hydroelectric developments is linked to the market for power which exists in India, but that market depends on agreement of terms between the two countries. All power

sites are confronted with exceedingly difficult transportation problems over long distances and in complicating geophysical circumstances. Existing generating capacity involves a small number of minor hydroelectric and diesel-electric units, and, according to data shown on table 1, these total 6,900 kw, corresponding to less than 1 watt per capita. Annual generation of 9,700,000 kwh corresponds to about 1 kwh per capita. Because there is no appropriate system of accounting, the total costs of production are not known, but it is clear that the rates on table 2, which range from about 1 to 3 cents per kwh, are heavily subsidized in that they reflect no amortization or depreciation, or no return or interest.

20. In Nepal, the desire to expand public utility services is very great, as the advantages of street lighting, house lighting, and limited power utilization are widely known, and the possibility of energy exports holds some promise of earning foreign exchange. In fact, energy exports might easily become the single largest exportable commodity. As noted above, small scattered generating units are already being relied upon for communication purposes and there are plans for developing isolated diesel-engine generating stations, ultimately to be pooled and integrated with the expanded hydroelectric resources. Fuel for diesel engines costs about 33 to 50 cents per gallon and is difficult to obtain.

21. *Somalia.* Addressing ourselves to still another less developed area, Somalia, we find a privately owned power system in the capital, Mogadiscio, and another limited system owned by the government in the town of Hargeisa. With two million inhabitants, the country itself is largely a desert. Most of the population

leads a nomadic existence, almost entirely separated from the commercial and limited industrial activities of the few towns.

22. Table 1 shows that about 6 watts of electrical generating capacity is available per capita and only 8 kwh are generated per year for each man, woman, and child. Table 2 shows that rates for industrial, commercial, and residential service are very high, ranging from 15.4 cents to 16.8 cents per kwh. There is a very heavy burden of taxes, port charges, and handling costs loaded onto the cost of fuel. Fuel for diesel engines ranges in cost from 37 to 50 cents per gallon. There are no low-cost energy resources. Accounting and operating practices of the power company are unregulated or uncontrolled.

23. The economy, which had been stimulated to producing food products, clothing, and other items needed by the Italian population and had grown to significant proportion prior to World War II, has now diminished as the Europeans have departed and their demands have not yet been replaced. It is conceivable that with numerous and generously distributed small generating units, encouragement would be given to the teaching-learning process and to the processing of hides and foodstuffs, etc., which might be exportable. There remains a considerable challenge to increased use of existing facilities, as represented by the 14 percent capacity factor shown in table 1.

24. *Uganda.* In the context of power supply and underdevelopment, Uganda presents an interesting example of problems to be faced in bridging the economic gap. Most of the population of over 6½ million lives a tribal existence in the bush and forests. Less than 500,000 live on organized farms or near to or in the communities created by the British and In-

dian peoples during the colonial era. These foreigners number some 80,000. The overall population density has been estimated at 27 per square kilometer. The land is said to be generally rich and there are mineable mineral resources.

25. A great and steady power-producing potential has been partially exploited at the outfall of Lake Victoria, where the Nile rises near Jinja. Here a hydroelectric project with extensive transmission facilities has been developed with existing installed capacity of 120,000 kw, and with foundations and waterways for 30,000 additional kw of capacity amounting to about 20 watts per capita, many times the corresponding ratio of the other underdeveloped areas treated in this report. The production of energy, 396 million kwh by industry and by the Electricity Board, corresponds to 59 kwh per capita. However, about 362 million of this production was for public utility sales and for export to Kenya. The sales to Kenya amount to about 160 million kwh. The ownership and generation of the power system rests in the Uganda Electricity Board, a government body or authority. Prices for electric service do not produce revenues equal to total costs. Prices in table 2 show that, for bulk and industrial service, rates are as low as 0.3 cents per kwh, and for minimal domestic use are as high as 14 cents. In 1960, average prices were about 0.4 cents per kwh to Kenya, about 0.8 cents to large industries, and 3.49 cents for standard tariff sales. With unused capacity available, there is a need to develop usage, and a promising attempt has been made by the Uganda Electricity Board to introduce specially manufactured low-cost, rugged, domestic water-heating and cooking devices purchasable on very easy terms over a long period of time.

26. Although the total population is large, the potential electricity consumers in the next 5 years are the few Europeans, some Asiatics, and a small percentage of the African population. All ways of increasing usage will have to be taken. The main power plant is far too big. The transmission lines connect to a non-compensatory load, Kenya on the one hand, and small scattered loads not justifying a costly system, on the other. It suggests that the capital invested in an "outsized" hydro-plant and an expensive transmission system might better have been applied to the installation of a large number of scattered, small diesel electric units.

27. *South Vietnam.* South Vietnam is a country of about 14 million people, having a density of about 80 per square kilometer, and has a long history of exposure to Western skill and practices. Literacy is relatively high and communication by written and spoken word is relatively easy. Complex political and social problems abound. There have been few peaceful years in the past thirty. Skills have been developing and there is an understanding of the problems, meanings, and implications of public administration. The gathering of statistics and the practice of accounting are well known, though not universally well followed. Electric-power generation and distribution were introduced and developed in numerous towns by private companies operating under colonial concession agreements consummated and administered by colonial officials. Regulation, as a matter of public administration, has not been rigorously practiced, although the concession agreements did provide for some controls without detailed accounting provisions. In recent years, since the republic was founded, a new system of

accounting has been introduced, based on a modification and adaptation of the system used by the U.S. Federal Power Commission.

28. A large hydroelectric project, several hundred miles north of Saigon, is being financed by the Japanese Government by way of reparations for war damage. The power will have to be transmitted to the population center and industrial complex of Cholon-Saigon. The route of the transmission linkage will follow a national road between the load center and the hydroelectric project. It will be over difficult terrain, and, considering the vulnerability of any transmission line to acts of sabotage, it is doubtful whether the new project will be able to make an appropriate contribution to the economy. The U.S. aid programs have sparked the construction of a steam-electric station now being built in Saigon. When completed, it is planned to burn indigenous semi-anthracite, should this prove to be feasible and economical.

29. The installed capacity, for public supply in 1959 amounted to about 98,000 kw, corresponding to 7 watts per capita. Table 1 shows annual production of approximately 280 million kwh, corresponding to about 20 kwh per capita. The price for domestic electric service in 1958 in Saigon was about 9½ cents per kwh and ranged up to 24 cents in some small towns. Almost all energy is generated by diesel-electric sets which, in Saigon, are supplemented by coal-burning, steam-electric units, the fuel for which was at one time mined in Hanoi. In recent years, anthracite was imported from eastern Pennsylvania at costs of over U.S. \$50 per ton. Diesel fuel, at one time, cost 18 cents per kwh.

30. *Greece*. This country has been selected as one representing an economy in transition approaching that of an advanced one. In the "Activities of the Public Power Corporation," published in 1962 in Athens, the per capita consumption in Greece over a span of 12 years was recorded as follows:

1950.....	70 kwh.
1960.....	220 kwh.
1961.....	250 kwh.

31. The major original electric development was that of private companies in the Athens-Pireaus area and in the city of Salonica. The prices for residential service have fallen from about 5 cents per kwh to about 3 cents. Greece has exploited to good advantage its well situated hydro-electric power potential, and has developed its lignite mines as sources of fossil fuel for power, although lignite is difficult to handle and to burn. Diesel fuel has been ranging from 11 to 15 cents per gallon.

32. Literacy, medical service, communications facilities, and widespread, fairly deeply-rooted skills were on a high level in Greece. The Greek economy has undoubtedly been stimulated by the existence and increasing development of a reliable, frequency-controlled, and voltage-regulated system of generation and transmission, but it is unlikely that without the factors of education, health, and skills, electricity at any price could have wrought the improvement suggested by the rise from 70 to 250 kwh of consumption per capita. It must be kept in mind that, in bringing electric service into an economy and in insuring its continuing expansion both on the supply and on the consumption side, reliance cannot continually be based on foreign aid by more advanced nations. The Public Power Cor-

poration has employed the capital savings and the initiative of the Greek economy to expand the electric system.

"An increased rate of economic growth is dependent on the increased formation of capital by productive investment of a larger proportion of the national income. Contributions to such increased formation of productive capital could be the retention and reinvestment of a larger proportion of the earnings . . ." (3) Table 1 shows relatively high per capita ratios of generating capacity and of production.

33. *The United States*. The development of the United States from about 1800 to about 1900 saw the population increase from about 5,300,000 to about 76,000,000. At this time, the American people were largely devoted to agricultural pursuits and were living in rural areas without electricity. During the hundred years, human power was supplemented and supplanted by animal power, by heat transfer, and by hydro-mechanical energy and the economy was a lusty, dynamic one, even without electricity. The public supply corresponded roughly to 33 kwh per capita per annum. The total installed capacity in industry and in public utility operations amounted to less than 40 watts per capita. The average price of residential electricity was then about 17 cents per kwh (17 cents per kwh, adjusted for changes in value of the dollar, would suggest \$1.36 per kwh). The enormous growth in population in the years from 1900 to 1960 (76,000,000 to 180,000,000) was accompanied by a tremendous growth in economic activity, complexity, and productivity. This growth was accompanied and assisted, to be sure, by the expansion of electric service, but whether such growth would not have occurred in the

absence of electricity is a moot question. Certainly, the growth patterns would have been different.

34. It is also clear that electricity came to a people prepared to apply and use it. So far as illumination was concerned, there was widespread use of gas and the Wellsbach mantle before the advent of electric light. By 1960, 185,000,000 kw of capacity were available in industry and for public service, corresponding to about 1 kw per capita. Generation of 840 billion kwh in the year 1960 corresponded to about 4,700 kwh per capita of which about 4,200 kwh per capita were produced by public-utility service agencies and the price of electricity for residential service had dropped to 2.47 cents per kwh.

### Concluding Comments

35. It is our basic assumption that electricity, if available at all and at almost any price, may facilitate education and promote the beginning of economic development. There is a corollary assumption that any useful application of electric power depends upon increased development of skills, simple but effective good government, reasonable distribution of goods and services, and ever-increasing spread of medical services and better health. With these improvements of the human resources, the advent and development of electricity may become the catalyst whereby great jumps may be encouraged, especially if there are present untapped natural resources. Thus, it may be concluded that technical knowledge and capital are but two of a very long and impressive list of missing elements generally confronting the initiating of a power supply in developing areas.

36. President John F. Kennedy, on September 2, 1962, said "Many recent studies including surveys of the development of the United States, have indicated that human skills and technology are an even greater factor than capital investment in effecting a rapid transition to a developed country." (4) It is probable that the low-capacity factors shown in table 1 are not due to price of electricity as much as to the lack of skills in putting it to use.

37. Based on experience in the six less developed areas, and in a single transitional one, and based on the history of electrification in the United States, it is believed that, prior to industrialization, small-scale rural power plants and small but well-distributed urban plants would encourage the processing of agricultural products and freezing and preserving food otherwise subject to spoilage. Pumping would be undertaken to improve irrigation and animal husbandry and to encourage betterment of public health and there would be a tendency to improve the human food supply by replacing work animals and agricultural crops raised to feed them.

38. Eugene R. Black, President of the International Bank for Reconstruction and Development, said "there is simply no practical way to raise this money (for expanding public utility service) unless a substantial part of it is generated by the utilities themselves through adequate charges to users of their services. . . . We have held that it is dangerous for a developing country to be sentimental or politically expedient about things like railroads or power plants, that policies based on these attitudes only create an intolerable drain on the savings which are the lifeblood of every country's future prosperity." (5)

39. All too frequently, a visitor from an advanced economy notes the prevailing high prices of electricity and the low level of economic development and relates the two. Although without some electric power it is difficult to lift any economy, its availability, reliability, controlled frequency, and regulated voltage are probably more significant contributors to economic viability than price. What is frequently overlooked is that the cost of wiring, the cost of bringing in the service, and the acquisition of utilization devices may be so far beyond the cash means of the potential consumer as to prevent his taking service at any price.

40. Dr. Robert Brittain, in a talk before the Society for International Development, has given what may be the most cogent reason and purpose for a diversified but small-scale power supply. He has suggested television teaching, utilizing a community viewing center, as the most promising method yet devised for overcoming adult illiteracy in underdeveloped areas.

41. The initiation of a limited power supply—if well thought out—may act as a catalyst in promoting the learning processes by illuminating living quarters and public buildings, and by providing power for community teaching television centers, and by powering small-scale pumping and irrigation projects, food-processing and freezing plants, and lumber mills. As an initial step in electrification, it would be preferable to install a number of package diesel units having standardized parts all of one design and manufacture varying capacity by having units of differing numbers of cylinders.

As a village outgrows its unit plant, a larger one or an additional one might be added. The flexibility of shifting units should commend itself to the planners of the economy. These developments in rural life will brake the tendency to create slums by slowing the flight from the villages.

42. Development can be sparked by outside help, but beyond the initial stages capital for expansion or growth must come from savings, not from foreign aid. It is evident that plants disproportionately large or poorly situated siphon off important funds which could have been applied to the construction and operation of schools, hospitals, roads, and communication networks. Some outsized plants appear to have been built in the hope that they would permit rates to be so low that creation of new industries and wide electric utilization would follow. In the absence of adequate money earning power, large segments of the populace may witness a potential good, without having means for enjoying it. On the other hand, poorly situated plants may be so vulnerable to storms, accidents, and sabotage, as to discourage industrial developments dependent upon them for reliable power.

43. Except for the obstacle to the development of heavy chemical and electrolytic processes created by high rates, electricity at almost any price, if widely available even in small quantities, can make a significant contribution to economic progress. Easy availability and wide distribution appear to be more important than low cost in initiating any power supply.

### REFERENCES

- (1) Murden, F. D., *Underdeveloped Lands, Revolution of rising expectations* Foreign Policy Association #119 (1956).
- (2) Galbraith, J. K., *Economic Development in Perspective*, Harvard University Press (1962).
- (3) Scharff, M. R., *Manual of the American Society of Appraisers* p. 47 (1960).
- (4) *The New York Times* (September 3, 1962).
- (5) Paper before the Economic and Social Council of the United Nations at Mexico City (April 10, 1959).

---

# Rural Electrification and Rural Development\*<sup>1</sup>

DALE J. HEKHUIS

*Economist*

THOMAS O. PAINE

*Manager of Engineering Applications*

GEORGE STREET, JR.

*Engineer*

*General Engineering Laboratory, General Electric Company,  
Schenectady, New York*

FRANK L. TURNER

*Economist, Stanford Research Institute, Menlo Park, Calif.*

E. GORDON ALDERFER

*Deputy Executive Director, CARE, Inc., New York City*

## Introduction

1. Rural electrification in less developed countries is widely viewed by development policy-makers, planners and administrators as essential to rural development. The validity of this view obviously depends upon what is included in the term "rural development." Is it the development of the small village, the cluster of villages, or the market town? Is it the development of a large area such as the block in India, or an entire region like the Cauca River Valley in Colombia, encompassing parallel programs of agricultural modernization and industrial decentralization? Does rural development include social improvements resulting from the provision of such amenities as illumination, radios, and refrigeration? The critical question is: Electrification for what specific purposes?

2. In this paper we examine the relationship between rural electrification and rural development by considering the role and socioeconomic significance of small power-generating units in the development of village communities, and alternative approaches to relating rural-electrification projects to viable rural-development opportunities. It is clear that the productive use of electricity in rural areas depends upon effective load-building programs integrated with rural-electrification programs.

## Small-Scale Power Units for Village Development

3. *Electrical Energy Generation.* Field investigations were carried out recently in rural areas of India, Colombia, Chile, and Peru to assess the need for and the impact of electrification on rural development. At the outset it was hypothesized

\*U.N. Conference paper.

that a small-scale engine generator capable of utilizing a variety of indigenous fuels would be an effective and economical means of supplying from 10 to 15 kilowatts of electric power to rural villages. This hypothesis was not borne out in either India or Latin America from the generation or productive utilization standpoints.

4. In the limited number of instances where it was judged that the local generation of electrical energy could make a productive contribution at the village level (population 2000-3000), the field studies showed that a 50 kw unit would be the minimum size required. In addition, it would be advisable at the outset to install excess capacity for future load growth. Further, some reserve or stand-by capacity should be provided to assure a dependable supply. These requirements are well above those originally estimated, and have substantial implications for the alternative fuels that can be considered.

5. It was found that, in practically every case, supplies of local fuels such as wood, rice hulls, dung, straw, leaves, etc., were insufficient to meet the daily

requirements of an engine-generator of adequate size on a dependable basis. Table 1 shows the estimated daily fuel requirements of a 15 kw generator powered by a closed-cycle compound steam engine. Some of these fuels are seasonal in supply (e.g., rice hulls and straw) and are too bulky to stockpile. Some have other uses besides fuel—agricultural mulch, fertilizers, building materials, or animal feed. Some are concentrated geographically, for example, coal in India and Colombia, where the cost of transporting coal into the villages is an effective deterrent to its widespread use. Wood is available in certain areas, as in the Indian State of Orissa or in southern Chile, but, in general, wood is either not available in the quantity required, or is too expensive.

6. The biogas generator which has been developed in India for animal dung offers a limited potential as an energy supply, and has the added advantage of producing a fertilizer residue. Family-size units of 100-cu. ft. daily capacity have been built and tested by the Indian Agricultural Research Institute. Gas production of this unit is sufficient for lighting

TABLE V. *Daily fuel requirements of a 15-kw generator operating at a 30-percent load factor*

Plant	Fuel	HHV (btu/lb)	SFC (lbs/kwhr)	Plant eff. (%)	Fuel rate (lbs/day)
Diesel electric.....	Diesel oil.....	19,750	0.75	23.1	80
Gasoline-electric.....	Gasoline.....	20,750	1.11	14.8	120
Closed cycle, compound steam engine electric.	Diesel oil.....	19,750	1.15	15.0	125
	Bunker C oil.....	18,000	1.27	15.0	140
	Coal.....	11,800	1.93	15.0	210
	Wood.....	8,500	2.68	15.0	290
	Agricultural waste.....	7,500	3.04	15.0	330

HHV=Higher heating value; SFC=Specific fuel consumption.

(4-5 cubic feet of gas per hour for a gas lamp) and cooking (10 cu. ft. of gas per hour per burner). At its current stage of development, however, the biogas unit is too expensive for the average villager.

7. Widespread distribution systems for diesel and gasoline fuels exist in both Latin America and India. Under these circumstances, reliable internal-combustion engines would appear to be the most appropriate equipment for local energy generation. However, diesel power is usually too expensive both in terms of the ability to pay and existing rural electric-rate structures. This is particularly true in India, where the price of high-speed diesel fuel in rural areas ranges from 50 to 60 cents per U.S. gallon, reflecting the high tax designed to discourage consumption of imported petroleum fuels. It is less true in Colombia and Peru where domestically produced diesel fuel is considerably cheaper, ranging from 10 to 16 cents per U.S. gallon. The cost of diesel-generated power in India based on a 50-kilowatt-unit operating at a 30-percent load factor using high-speed diesel fuel at 42 cents per U.S. gallon approximates 10 cents per kilowatt-hour. In Colombia the cost would be about 6 cents per kilowatt hour, with fuel at 10 cents per U.S. gallon.

8. The upland areas of Chile, Peru, and Colombia in the Andes have many glacier-fed streams with a year-round hydroelectric potential of 50 to 500 kw. Because of their steep gradients (150 to 300 feet per mile) these streams are a potential economical source of locally generated electricity. This resource has been exploited to only a limited extent for rural electrification and many excellent opportunities exist.

9. Wind-generated electricity offers few opportunities for practical application in

India or Latin America. At Alta Plano, in upland Peru, there are sustained daytime winds. The north coast of Colombia also has low-velocity (10-15 mph) sustained winds throughout the year. However, these regions also have readily available gasoline and diesel fuels at prices so low that the generation of any useful level of electricity by wind power would be noncompetitive. The most effective use of wind power, where available, would appear to be for pumping rather than for the generation of electrical power.

10. Solar power also appears impractical for near-future rural electrification. Substantial research and development work remains to be done to increase conversion efficiencies and to reduce equipment costs in order to compete with presently available power-generating equipment.

11. *Utilization of Electrical Energy.* Generally speaking, the on-site investigations of representative rural communities in India and Latin America revealed only limited opportunity for the productive application of electric energy supplied by small-scale generating units.

12. Where irrigation is required, direct diesel pumping is, of course, more economical than electric-pump sets supplied with electric energy from small-scale generating units. Further, given the Indian land-tenure pattern of 3 to 4 acres in many cases, it is difficult to justify either a diesel or an electric pump. The Indian Government is making attempts to consolidate holdings, but in many parts of the country the size of the holdings is so small that even consolidated holdings will require common sharing of pumped water, an arrangement which has so far been extremely difficult to arrange to the satisfaction of the parties concerned. The

social problem is the critical factor here.

13. There also appears to be very little potential for the productive use of electricity by small industry at the village level because the traditional industries— weaving, tanning, oil expelling, shoe-making, etc.—cannot begin to compete with the larger and more efficient units in towns and cities. Currently these village industries are economically marginal or submarginal, the daily income per Indian artisan ranging between Rs.50 to Rs.1.25, or 10 to 25 U.S. cents. Under those special circumstances where it is appropriate to perform certain processing operations at the village level, such as grain grinding or oil expelling in a village that lacks access to a market town, it would appear to be more economical to utilize the shaft power of an internal-combustion engine directly rather than to convert shaft power to electric energy to power a small electric motor. For illumination it is usually less costly to utilize kerosene or gasoline-mantle lanterns than to use this same fuel to power a small-scale engine-generator supplying electricity to an electric light bulb in the absence of other loads. Productive uses must be developed to achieve a minimum load factor to make electrification practical and economical.

14. Given the present limited opportunity for the productive application of electric energy, which works against the possibility of achieving an appreciable load factor, and given the favorable economics of direct shaft power as against electric energy for satisfying the principal existing requirements for power, it appears doubtful that the introduction of small-scale generating units can be justified at the village level, with the possible exception of small hydro-units. This is not to say, of course, that power may not

be a worthwhile social and political investment for purposes of improving rural amenities and avoiding dissidence. It is important to be clear with respect to the costs of providing such services, however, and in the absence of significant productive applications of electric energy in agriculture and small industry, to face up to the possibility that uneconomical highly subsidized electric services may not prove to be permanent.

#### Rural Utilization of Power in Colombia and India

15. *Electricity Utilization in Rural Colombia.* Table 2 presents data on the percentage of the rural population in Colombia with access to electric power. The data indicate that in 1960 approximately 23 percent of the rural population had no access to power, and that the bulk of the population with access to power were supplied by Class G plants (less than 100 kw). Energy generated by

TABLE 2. *Rural population with access to electric power in 1960\**

[Unit: thousand persons]

	1960	Per- cent
Total rural population.....	8,436	100
Estimated population without power.....	1,973	23
Population served by B, C, D, E, F class plants.....	3,014	36
Estimated population served by G class plants (less than 100 kw).....	2,734	33
Population with grid power....	715	8

\*Rural population is defined as persons residing in communities of less than 1,600 inhabitants. The total 1960 rural and urban population of Colombia was 14,987.

these plants is used almost exclusively for illumination, and it is estimated that about two-thirds of the total electricity generated by Class D-F plants (100 kw-5000 kw) is also used for lighting during a few hours of the early evening.

16. A review of load-factor data for rural Colombia shows a rough correlation between load factor and the percentage of the rural population served, i.e., the greater the rural population served, the lower the load factor. For example, in Giradot, 143 kilometers southwest of Bogotá, the percentage of rural population in the area served by the local power company is only 8 percent, and the load factor is 40 percent. In Sahagun in Cordoba Dept., the rural population served is 85 percent, and the load factor 20 percent. The load factors of companies providing power from hydro facilities, however, are much better than those of diesel-generating companies; this is undoubtedly associated with the lower hydro rates, which are about one-third of those charged by diesel-based companies. In any case there is a basic need to develop higher load factors.

17. Although electricity from small-scale diesel and hydro generators had been available to a number of the rural communities surveyed for 30-40 years, there was a singular lack of application of power for purposes other than evening illumination. This indicates that the mere availability of limited power is insufficient to bring about productive applications. It also suggests that there has been little comprehension of alternative productive uses for power.

18. *Electricity Utilization in Rural India.* The degree of rural electrification differs substantially in various Indian states. Four states that have made much progress have electrified the following per-

centages of their towns and villages: Kerala (36 percent); Madras (32 percent); Andhra Pradesh (8 percent) and the Punjab (10 percent). Various factors have tended to facilitate rural electrification in these areas. In Kerala there is a relatively low proportion of smaller villages—only 12 percent of the villages have a population of less than 500—compared to the all-India average of two-thirds. In Madras and Andhra Pradesh also, the typical village tends to be somewhat larger in size. Significant irrigation pumping loads in these areas supplement lighting loads, and, in addition the Madras, Kerala and Punjab power systems include a substantial proportion of low-cost hydroelectric power.

19. It must be pointed out that even though these States are first electrifying the optimum villages from the standpoint of load building and use factors, rural-electrification programs are still very heavily subsidized. In Madras, for example, the State Electricity Board has estimated that the total annual subsidy to rural users in 1958, when only 4,000 villages were electrified, was 1½ crores of rupees, or 3 million U.S. dollars. This subsidy is estimated to total almost half the cost of supplying rural electricity, and is high in relation to the planned annual investment under the Third Five Year Plan of 6 crores of rupees to extend electricity to the remaining 8,000 villages in Madras. Despite the subsidies and rates as low as 1.5 to 2.0 cents per kwh, use factors are extremely low.

### **Electrification and Viable Rural Development Programs**

20. *Indian Village Industry Programs.* India's village-industry development programs date back to the teachings of

Ghandi and his followers, who created the All-India Spinners Association and the All-India Village Industries Association to revive and encourage traditional rural industries including the "charka" (hand spinning) and weaving industries. There were important social aspects of these efforts, and village self-sufficiency was a prime objective. A great deal of effort has gone into programs aimed at implementing these ideas. For example, in 1956, as part of a national small-industry program that was having considerable impact in urban areas, 26 pilot projects were sanctioned in villages with the special aim of accelerating rural industrialization. Both new and traditional village industries were established. Of the 26 pilot projects, only 15 were really started, and of these only 9 were considered successful. The most successful in the final analysis were those involving traditional industries, namely, spinning and weaving. Even here the "successes were heavily subsidized." The evaluation of this effort made in 1959 stated: "The experience of these projects shows that where there is no electricity, and other facilities for the growth of small industries are lacking or are inadequate, and where the area is generally backward, a program of assistance to traditional and village industries can still be undertaken . . ." (1). It is generally recognized that the results of these efforts have not been encouraging. Industry has gravitated to those centers where it can operate most effectively, namely, where raw materials, labor, power, transportation, capital, and markets are all available. During 1951-57, 47.2 percent of the new manufacturing enterprises in India were located in Class I cities of over 100,000, 19.3 percent in Class II and III cities (20,000-100,000 population), and 33.1

percent in towns of less than 20,000 population (2).

21. *The Village vs. the Market Town as Nodal Growth Center.* In Colombia the typical "vereda" is a collection of huts, inhabited by 200 to 500 persons engaged in non-mechanized subsistence farming. The traditional grouping of people in a vereda is based on ready access to the small plots of land farmed and on social and security considerations, rather than on present-day economic factors. For marketing and the purchase of necessities, the inhabitants of veredas travel to the nearby "pueblo" or market town, which usually constitutes the administrative and economic center of the larger "municipio" or county. Retail merchants and wholesale buyers of coffee, yucca, sugarcane, and livestock typically operate in the market town. The principal church, schools, and the circuit judge for the municipio are also located in the pueblo. The municipio areas surrounding these market towns vary widely in size and in the proportion of rural and urban inhabitants, although there is a rough correlation between the total population of a municipio and the number of pueblo inhabitants.

22. It would appear that the existing concentration of economic activities and population in the market towns offers the most promising economic base for rural industry, midway between major modern urban areas and small veredas. The pueblo also appears to offer promise of the greatest economic return for rural-development programs associated with the productive utilization of electric energy. The generally ready access by villagers to the market center further suggests that economic and social improvements in the pueblos would have an impact on the rural inhabitants of the

TABLE 3. *Electric power requirements for small scale industries in Colombia—1959\**

Category of industrial establishments by number of employees	Number of industrial establishments per category in Colombia	Total installed horsepower per category	Average horsepower per industrial establishment	Average kw required per industrial establishment
1 to 9 employees.....	6,550	40,400	6.2	5
10 to 24 employees.....	2,326	47,400	20.4	15
25 to 49 employees.....	835	54,700	65.5	50

\*Source: Government of Colombia, Departamento Administrativo Nacional de Estadística, via Banco Popular, Bogota, (1962).

municipio in terms of higher employment, income, and amenities. Possible types of small industry suitable for market towns in Colombia that can help build productive electric-power loads include: agricultural product processing, construction materials, leather goods, woodworking, pottery, and apparel. It cannot be assumed that any given industry would prove successful in any locality, of course, inasmuch as the availability of markets, raw materials, management, and capital will vary. The data in table 3 relate average power requirements to other characteristics of industries in various size categories ranging from 1 to 9 employees up to 25-49 employees.

23. In India it is difficult to conceive of the small village as an initiator of new industry, although the traditional industries (khadi, coir, handlooms, etc.) have evolved over time within the village. Modern small industries imply a degree of specialization and urban training not available within the village. This training must be imported by either bringing entrepreneurs and skilled workers to the village or by selecting promising villages and training them. The Karve Committee, which helped pave the way for the small-industry program in India, had this

to say about the pattern of industrial decentralization (3).

"The pattern of industrial activity that should gradually emerge is that a group of villages having its natural industrial and urban centre. These small urban centres will be similarly related to bigger ones. Thus a pyramid of industry broad-based on a progressive rural economy will be built up. In such an organization small centres can experience a cooperative interest in the bigger ones, and these latter would develop a genuinely supporting instead of an exploitative relationship towards the smaller towns and the countryside."

24. This brief discussion highlights the fact that the issues of urban versus rural development, or centralized versus decentralized growth, and regional balance in development, are clouded by many complexities. In the meantime, economists, sociologists, and planners will have to do some "educated guessing." This kind of educated guessing was undertaken by a large number of high-level officials and economists who attended a seminar on rural industrialization sponsored by the Ford Foundation in March 1960 (4). The main conclusion of this meeting

seemed to be that industrial decentralization would at best mean decentralization from the very large urban centers toward the smaller towns and that rural industrialization could not be conceived of as a village goal, but as an area objective. Within given areas of rural India, nodal growth centers would provide a need and opportunity for clusters of small industries. It is around these clusters, probably located in market towns, that a foundation for rural industry might be established. Similar conclusions appear appropriate for the Latin American situation.

25. *The Systems Development Approach*. The preceding discussion suggests that there is a need for an approach to rural development that would consider the interrelationship between the provision and productive utilization of electricity from the viewpoint of the systems analyst. The systems analyst would be concerned with an electrical energy supply system consisting of generation, transmission, and distribution subsystems, and an energy-utilization system consisting of the agricultural production, small industry, and consumption sectors of the rural economy. The type of generating system and the cost of delivered energy are ob-

viously influenced by the characteristics of the load to be supplied and the utilization system. The "scale" problem is critical in identifying the various types of small industries and processes which are viable for rural areas. Electrification can only be planned in relation to the total rural-development program. In anticipating and appraising the impact of energy on a newly electrified area, one must consider both the economic system and the social system. In fact, social factors may well override technical and economic considerations.

26. We draw the conclusion, therefore, that the market town offers the most promising site for rural-electrification projects integrated with viable rural-development programs. An effective electric load-building program must be provided to develop productive use of electricity to achieve an economical load factor; the mere provision of electricity is insufficient. Small-scale (10-15 kw) generators utilizing local fuels, wind, or solar power do not appear to have significant practical application potential. The minimum-size generator to be considered for a town of 2,000-3,000 population is 50 kw, with additional capacity for growth and standby very desirable.

#### FOOTNOTE

<sup>1</sup>The work reported in this paper was sponsored by the Research Evaluation Planning Assistance Staff, Agency for International Development, U.S. Department of State, under General Electric Contract A.I.D.-REPAS-1. The opinions expressed are those of the authors and do not necessarily reflect the views of the sponsoring agency.

#### REFERENCES

(1) *Report of the study team on community development*, Industrial Pilot Projects, Ministry of Community Development and Cooperation, Government of India, p. 50 (December 1959).

---

(2) Bredo, W., *Industrial development and urban growth with particular reference to industrial location*, Paper 9, Seminar on Urbanization in India, University of California, Berkeley, California (1960).

(3) *Report of Village and Small Scale Industry Committee*, Planning Commission, Government of India, New Delhi, p. 22 (October 1955).

(4) Morse, R., *Rural industrialization in economic development*, Seminar Report, the Ford Foundation, New Delhi (April 16, 1960).

# Typical Problems in the Development of Modern Power Supply in Less Developed Areas \*

WALTON SEYMOUR

*Vice President for Industrial Development,  
Development and Resources Corporation,  
New York City*

1. It is the purpose of this paper to describe, in terms of some specific areas concerning which the writer has personal and professional knowledge, the situation of electric-power supply before and after major development efforts. In each case a new institution was established which undertook to expedite a process of change as one of its major functions. Of these institutions, each has a framework of major characteristics which is of interest. The specific problems with which these new agencies dealt are set forth, and the actual solutions that were adopted are stated. The present status of power supply and prospects for the future are also summarized.

2. The cases include the areas served by the Tennessee Valley Authority (TVA); Greece, which is served by the Public Power Corporation (PPC); El Salvador, where increments of power supply are the responsibility of the Comision Ejecutiva Hidroelectrica del Rio Lempa (CEL); Puerto Rico, served by the Puerto Rico Water Resources Authority

(PRWRA); and the Khuzestan region of Iran, where a modern power system is under development by the Khuzestan Water and Power Authority (KWPA).

3. The final portion of the paper summarizes some conclusions, based upon the experience in these five areas, which are of potential significance in other areas facing somewhat similar problems in providing modern power supply for their homes, farms, commercial establishments, and factories. Especially to be noted are the common elements in the individual solutions developed in each of the areas. These common elements may well be significant for other areas because they can be clearly identified in the five cases, and because, in all five, modern electric-power supply has been or is being achieved in areas where electric service had previously not met modern standards of adequacy, reliability, and reasonableness of cost.

## The Cases

4. *The TVA Area.* In 1933, during the early days of the administration of

\*U.N. Conference paper.

President Roosevelt, the law was passed which established the Tennessee Valley Authority. The TVA Act was the conclusion of a series of preceding but unsuccessful efforts to establish an agency for development of the resources of the Tennessee River and the region through which it flows. Key policies for electric power included the following:

(a) The TVA power system was to be self-supporting and self-liquidating; it was to be able to use its revenues for power-system purposes.

(b) Power was to bear its share of the costs of facilities used also for TVA's primary purposes of flood control and navigation.

(c) TVA power was to be conceived as being available primarily for the benefit of the people of the section as a whole, with preference for the domestic and rural consumers, and the sale of power to industry was to be a secondary purpose, primarily to secure a high system-load factor and to improve revenue returns; TVA was to seek the application of electric power to the fuller and better balanced development of the resources of the region.

(d) The Act clearly implied that TVA was to sell power primarily on a wholesale basis, giving preference to public and cooperative agencies not doing business for a profit.

(e) In lieu of taxation, TVA was to pay a percentage of its revenues from the sale of power to the States within which it operates, a part of these payments to be paid to local agencies of government which suffered loss of tax revenues due to TVA's acquisition of properties formerly in private ownership. This is now 5 percent.

5. Some of TVA's other key policies applying to all of its operations are these:

(a) It was to have much of the flexibility of a private enterprise; for example, its employees were to be appointed without any political tests and were to be employed under a merit system with salary classification established by TVA, independent of the U.S. Civil Service system.

(b) Its Board was to consist of three members, chosen by the President with the consent of the Senate, responsible to the President and with staggered terms, ultimately 9 years each to assure continuity through changes in national administrations.

(c) Its accounts were to be kept in accordance with the Federal Power Commission system of accounts.

(d) It was given the power of eminent domain.

(e) It was to have authority to take necessary action to carry out these policies.

6. By 1933, in the Tennessee Valley region power supply was, in most cases, available from large central-station sources only in the major centers of population. There were a number of isolated municipal systems, usually depending on diesel-electric generators. Rural electrification extended to only 3 percent of the farms. Average residential use was 600 kwh per year, about the same as the national average. Total regional electrical energy requirements were about 1½ billion kwh. In hearings about TVA legislation and appropriations, representatives of existing power systems testified that the future market for power in the region was limited and the capacity planned for installation by TVA was not required.

7. One of TVA's statutory tasks was to develop a comprehensive plan for inte-

grated development of the Tennessee River and its tributaries. This was completed in 1936 and guided future development.

8. TVA, located in an area which was predominantly agricultural, began its operations with a labor force in which modern industrial skills were limited. Training of foremen, accountants, managers, and skilled workers was an essential element of its early program.

9. In order to develop the region's power supply on the most economical basis, an integrated generation, transmission, and distribution system was required. This was accomplished largely through the acquisition by TVA of the existing bulk-supply (generation and transmission) facilities, and through acquisition of the existing distribution facilities by local public agencies, and by cooperatives, which became the distributors of TVA power. Acquisitions were negotiated at prices agreed upon between buyers and sellers. The acquisition program was completed in 1945 and included properties for which sales prices totalled about \$125 million. The facilities thus acquired were interconnected with newly constructed facilities owned by TVA and by the municipal and cooperative distributors of TVA power.

10. TVA's financing has come primarily from direct Congressional appropriations and from its own earnings. The early acquisition program was financed in part by the issuance of bonds which were purchased by the U.S. Treasury. Within the past few years, TVA has been authorized, by amendment of the Act, to issue up to \$750 million in revenue bonds for sale to the public to finance the further expansion of its power system within its existing service area.

Some \$100 million of such bonds have since been issued.

11. TVA now supplies power throughout an area of some 80,000 square miles, with a population of some 5 million and with about 1½ million consumers of electricity. Total requirements for electrical energy have reached 60 billion kwh, or about 40 times their level of 30 years ago. Almost half of these requirements are for national-defense purposes, including atomic energy. Ninety-eight percent of the farms in the region have electric service. A high proportion of all new homes are heated with electricity. Average residential consumption is almost 10,000 kwh per consumer per year, or about 2½ times the national average. The average rate for this service in the TVA area is a little less than 1 cent per kwh, or about 40 percent of the national average. With total-system generating capacity of over 12 million kw, TVA ranks as one of the largest integrated power systems in the world. Having practically exhausted the economical hydroelectric power in its region, it will, in the future, depend largely upon thermal sources to meet its continued growth requirements. It now uses about 20 million tons of coal per year. TVA has a cooperative understanding with the Atomic Energy Commission for work on an experimental gas-cooled reactor for power purposes.

12. *Greece.* When fighting ceased in Greece in 1949, it was recognized that electric-power supply should have a high priority in the work of reconstruction and expansion which needed to be done. A survey of power requirements and some of the principal power resources was made by a firm of consulting engineers, Ebasco Services, Inc., of New York, financed by U.S. aid funds. Following

---

the completion of this survey, the U.S. and Greek Governments agreed that electric-power development would be one of the major programs during the period of reconstruction, to be financed in part by Marshall Plan funds, in part by Italian reparations, and in part by Greek resources.

13. In 1950, the Greek Parliament enacted legislation to establish the PPC to own and operate the new power system, and Ebasco was employed for a term of 5 years to manage the affairs of the PPC, to train its personnel, and to supervise the contractors engaged in developing the new power facilities. Ebasco was responsible to the Greek Board of Directors of PPC for its work.

14. Before PPC came into being, the only modern electric system in Greece, with electricity in reasonably adequate supply at reasonable cost, was that belonging to the Athens-Piraeus Electricity Company (APECO), largely owned by British interests, and serving the metropolitan area of the capital. In the second city of Greece, Salonika, the urban electric system was partly alternating and partly direct current, and service was inadequate and costly. In 1950, a portion of that city's power supply came from small naval vessels moored at the quay and connected to the electric-distribution system. Salonika's entire system had to be extensively rebuilt and expanded. A few other urban centers had electric service but only on an inadequate and high-cost basis.

15. By 1954-55, PPC completed the first stage of a new nationwide system which included three hydroelectric plants, a large thermal-electric station, a 150 kv transmission system, and primary distribution networks at 15 kv. Service began to be extended to the villages of

Greece. Inadequate urban systems were replaced. Further power expansion was undertaken by PPC after the completion of the first program. In 1960, PPC acquired the APECO system. Today, PPC is responsible for power supply throughout Greece, including the Greek islands. Only a few local systems remain in their previous ownership, the largest being that of Patras.

16. In 1950, total generating capacity in Greece was less than 200,000 kw. By 1955, with the completion of the initial expansion program financed in part by U.S. aid, total capacity had doubled. The second expansion program now completed or under construction will bring the total generating capacity to about a million kw, or over five times the capacity in 1950. Further substantial expansion of the PPC system is now under design. Since 1955, development has been largely financed by earnings and by internal and external loans and equipment credits.

17. PPC's initial policies were set forth in its original enabling legislation, adopted in 1950, and in its subsequent amendments. It was to be an autonomous agency, responsible to the Greek State through the Ministry of Industry. Members of the Board of Directors were to be appointed by the Government on the Minister's recommendation. The members of the seven- (later changed to nine-) man Board were to have 5-year terms of office, for staggered periods. Power was to be supplied by PPC on a basis which would assure its availability at the cheapest possible cost to the consumer, while PPC covered its costs of service. There was to be no unreasonable discrimination in the sale of power between regions of the country or between customers of the same class. For its key personnel, PPC was to be exempt from

Civil Service rules and regulations. It was to be able to act as though it were a commercial enterprise. Its accounts were to be kept in accordance with best modern public-utility accounting practice. There was to be a representative assembly, consisting of representatives of government, labor, banks, industry, the principal municipalities, professional societies, trade associations, etc., with responsibility for general annual or special review of PPC's operations.

18. It was intended that the resources used by PPC for power supply were to consist primarily of those indigenous to Greece—water power and lignite. Before 1950, except for emergency use in wartime, these resources were practically undeveloped. PPC has been instrumental since that time in opening up a large lignite deposit at Aliveri, on the island of Euboea, to fuel a power plant at that location, and a very large deposit at Ptolemais in the north, to fuel another power plant and to provide raw material for industrial development. A 150-kv interconnection has been established with Yugoslavia.

19. Most of the villages on the mainland of Greece and many on the islands have been electrified under the PPC program. A standard set of rate schedules is applied throughout the PPC service area, including the islands, except in the capital region, where APECO's rate structure has been maintained by PPC, the new owner. The levels of average rates for the various classes of consumers are not significantly different in these two parts of the PPC territory.

20. PPC's rate of growth has averaged 10 to 12 percent per year, the growth being more rapid outside than inside the capital area. Total use of electrical energy was 538 million kwh in 1950, of

which 451 million kwh were used in the Athens-Piraeus area. Total use in 1961 was 2156 million kwh, of which 1445 million were used in the capital area. Plans for new power sources are under active consideration to meet future needs including the provision of a new large thermal-power station in the Peloponnese at Megalopolis, which will tap large lignite deposits in that area.

21. The hydroelectric development of the Acheloos River in Western Greece, which is to be interconnected with the national network, is the base for quite an industrial complex, including an aluminum smelter being erected by a combination of French and American interests.

22. Since 1955, PPC has been managed and operated by its Greek organization. The Ebasco management group was entirely withdrawn after expiration of its original 5-year contract, and consulting services have since been of a more technical and traditional character.

23. *El Salvador.* El Salvador, a Central American republic, has a population of about 2½ million, and an area of some 8,000 square miles.

24. In 1945-46, it was decided by the Government that a large increment of electric power was needed, and a hydroelectric development at Chorrera del Guayabo, on the Lempa River, with associated transmission facilities, was undertaken, after detailed investigations. In 1948, the IBRD undertook the financing of the foreign-exchange portion of the costs of this project. Harza Engineering Company of Chicago, Illinois, were the consulting engineers, and were responsible for design and supervision of the construction of the project. The dam is now known as the Fifth of November.

25. Before 1948, the only fairly large electric system was that in the capital, San Salvador (CAESS), which also served the surrounding towns. It is owned by a Canadian group. The same group owns the much smaller system serving San Miguel, in the eastern portion of the country. Another smaller system served Santa Ana in the west, and there were small scattered systems in other towns, most of them privately owned. In 1953, total generating capacity in the country was about 20,000 kw.

26. With the decision to move ahead with the Lempa development, the Government of El Salvador established, through legislation and executive action, CEL, a public entity owned by the Government. Initially established by decree to make the necessary preliminary studies and investigations, CEL was later (1948) given a legislative charter. CEL had a seven-man board of directors (with staggered 4-year terms), four of whom were designated as individuals by the Government (acting through four cabinet offices). Of the other three, one was selected by the banks; one from a list provided jointly by the local agricultural, commercial, and industrial associations; and one by the local bondholders (other than the Government). For each board member, an alternate was appointed by the same procedure.

27. The Lempa project includes four generating units of 15,000 kw each, two of which were installed by 1954, one in 1957, and the fourth in 1961. A second hydro-project, Guajoyo, is almost completed. It will control and utilize the outflow from Lake Guija, which lies athwart the border of El Salvador and Guatemala.

28. CEL's legislative charter gives it irrigation as well as power responsibili-

ties. It is exempt from civil service rules and regulations. It is to operate as an autonomous nonprofit public service enterprise. It is directed to give preference to the sale of power at wholesale to public or private agencies. Rates and charges are to be reasonable and adequate to cover costs, including debt service. CEL can borrow money in its own name, with Government approval. It has the right of eminent domain. Employees are to be chosen solely on the basis of merit and efficiency, without any political test. CEL and its contractors are exempt from customs duties, for imports necessary for its work, and from local taxation.

29. In 1953-54, CEL negotiated a wholesale power contract with CAESS, which specified wholesale and retail rates, and the maximum rate of return on investment which the company was to be permitted. This contract gives CEL the opportunity to assure that the benefits from the availability of CEL power are shared on a reasonable basis between the consumers and the owners of the company. Since return has recently exceeded the contractual allowance, retail rates were reduced in 1961.

30. Since 1953, the year before the Fifth of November project began operating, generating capacity in El Salvador has been quadrupled and requirements have risen equally rapidly. CEL now supplies over four-fifths of the country's electrical energy needs. Over 80,000 consumers are using CEL power. Service has been extended to most of the main urban centers from the CEL system, and contracts similar to that with CAESS have been negotiated with the distributors in other areas.

31. *Puerto Rico.* Puerto Rico, an island about a thousand miles south and east of Miami, Florida, bounded by the

Atlantic and the Caribbean, has an area of about 3,500 square miles. Its population is approaching 2,500,000. It is a Commonwealth within the United States, with a unique constitution established in 1952 by compact.

32. In 1942, legislation was enacted by the Puerto Rican territorial legislature establishing the PRWRA, an entity owned by the people of Puerto Rico. Its purposes were to produce and supply electricity, which it now does throughout the island, being responsible for serving all but a few of the ultimate consumers. It also had some irrigation responsibilities.

33. In 1942, PRWRA acquired the properties of the Canadian-owned company serving the San Juan capital area, and of the company serving the third largest urban center, Mayaguez. The privately owned system serving Ponce, the second largest town, had been acquired previously by the public agency which was the predecessor of PRWRA.

34. In 1941, the year before PRWRA was established, the total production of electrical energy for public use in Puerto Rico was about 192 million kwh; and 113,000 consumers were being served. Twenty years later, in 1961, total production was about 2,300,000 kwh, or a multiplication in two decades by twelve times. In 1961, over 400,000 consumers received service.

35. The legislative charter of PRWRA provided for the establishment of a three-man Board of Directors, the members to serve ex-officio, including the Governor, who was the chairman of the Board, and two members of his cabinet. Responsibility for managing the affairs of the agency was placed in the executive director, who was to be chosen by the Board. The PRWRA Act provides that charges for electric service fixed by PRWRA

shall be reasonable and adequate to cover costs, including obligations to the holders of the agency's bonds. It may borrow money in its own name and pledge its revenues for its debt service. It appoints its own officers and employees, and fixes their rates of compensation. It has the power of eminent domain, in the name of the people of Puerto Rico. In lieu of all other taxes, PRWRA pays 5 percent of its power revenues to the Commonwealth Treasury, and 6 percent is divided among the municipalities within which it operates.

36. The PRWRA system was in part acquired from its predecessor public agency (which was called Utilization of Water Resources, an office of the Insular Government), in part built with grants from the United States, and in part acquired or constructed with funds obtained through the sale of revenue bonds on the New York market. The most recent bond sale, in 1962, was in the amount of \$22 million, at an average annual interest rate of about 3.6 percent.

37. About 110,000 kw of PRWRA's generating capacity is hydroelectric. Since practically all of the economical hydro sites have been utilized, increments since 1956 have been thermal-electric. The thermal plants are fueled with oil, largely consisting of the heavy residuals available from the two oil refineries now in operation on the island, one in the north and one in the south. Total PRWRA generating capacity at June 30, 1962 was about 700,000 kw.

38. The expansion of rural electrification throughout the rather mountainous terrain has been rapid. The work is carried out under a program financed by the Rural Electrification Administration of the U.S. Department of Agriculture which buys some of PRWRA's bonds

each year, with an annual interest cost of 2 percent. Rural electrification is also supported by annual payment from the Commonwealth Treasury, in order to enhance its economic feasibility for PRWRA.

39. PRWRA is staffed almost 100 percent by Puerto Ricans. Many have had training in the continental United States. It retains Jackson & Moreland of Boston as its consulting engineers. Development and Resources Corporation is also retained for consultation and advice, especially in the fields of power economics and management policy. PRWRA, in cooperation with the U.S. Atomic Energy Commission, is constructing a 16,000-kw nuclear power plant (BONUS) in the western portion of the island. This plant will have the advanced feature of integral nuclear superheat with a boiling-water reactor.

40. Puerto Rico has for the past 10 years been engaged in what has become known as Operation Bootstrap, an intensive program of economic development. As a result, several hundred new industrial enterprises have been established on the island, transportation and communication have been improved, modern water-supply and sewerage systems have been built, and the standard of living has been significantly raised. Income from industrial activity now exceeds by a significant margin agricultural income, which had been the predominant income source throughout the island's recent history. One of the prominent factors in support of this development program has been the availability, thru PRWRA, of an adequate supply of electric power at reasonable cost. PRWRA's rates for electricity are comparable with those of electric utilities serving the Atlantic seaboard of the United States. They lie roughly

in the middle of the range of these schedules between the high and low extremes. PRWRA is now the second largest non-Federal publicly owned electric system in the United States and its territories.

41. *The Khuzestan Region of Iran.*

In southwestern Iran, bordering the head of the Persian Gulf, lies the region known as Khuzestan. It comprises an area of about 58,000 square miles, with a population of about 2½ million. It includes a broad desert plain, very flat, extending from the Gulf to the Zagros or Bakhtiari Mountains to the north and east. In the foothills of these mountains lie most of the producing oil fields of Iran.

42. The plain is drained by five rivers. On one of these, the Dez, there is rising toward early completion a thin-arch concrete dam, sixth highest in the world, which will have initial generating capacity, in two units, of 130,000 kw, and ultimately an eight-unit capacity of 520,000 kw. It will be placed in operation in early 1963.

43. In 1956, Development and Resources Corporation was asked by the Government of Iran to assist in devising a plan for the economic development of Khuzestan, the region which, for many centuries, was the source of the economic power of ancient Persia. After receiving and approving the recommendations, the Government asked the firm to assume responsibility for helping to execute them. The firm completed and delivered to Plan Organization a unified program for development of Khuzestan. This program included a total of some 6 million kilowatts of hydroelectric capacity in fourteen projects, and water supply for a million hectares of agricultural land.

44. In 1957-58, electric-power supply in Khuzestan was primitive. The only partial exception was Abadan, where the

oil companies have one of the largest of the world's refineries. There the companies were supplying their own employees, who constitute the majority of the electricity consumers of the town. In the other urban centers, there were various combinations of public and private systems, with no control or regulation. Service was unreliable and otherwise inadequate, connection charges were exorbitant, and rates were not such as to encourage the use of the service.

45. As part of the development program, in 1959, a 132-kv transmission line was placed in service between Abadan and Ahwaz, the capital of Khuzestan province. This was used to deliver to Ahwaz power purchased from the oil companies at Abadan. The Ahwaz distribution system was rehabilitated and expanded. The number of consumers served has grown from 7,000 in 1958 to 18,000 in June, 1962. Included in the Ahwaz service area are about 10 surrounding villages previously without electric service of any kind. Power demand on the Ahwaz system quadrupled in 3 years.

46. As a basis for system rehabilitation and expansion in Ahwaz, D&R negotiated on behalf of the Government the acquisition of the privately owned system in the town and integrated it with the municipal system under the ownership of the newly formed company owned by the municipality. D&R is assisting the Government in managing the affairs of this company and training its organization. A wholesale power contract, which establishes retail rates and terms of sale, was made effective. A similar series of steps is in progress in the four other urban centers of Khuzestan to which Dez power will initially be made available.

47. As part of the plan, in 1960, the Government established the Khuzestan Water and Power Authority to carry on the development program, and gradually to assume D&R's responsibilities. KWPA has its own legislative charter, which places primary responsibility for its affairs upon the Deputy Prime Minister and head of the Government's Plan Organization. The Deputy Prime Minister can delegate his powers to the managing director of KWPA whom he also recommends for appointment by the Prime Minister. Such a delegation has been made. KWPA, under its charter, may use its revenues to finance its operations, may appoint its own officers and employees and fix the levels of their compensation. It establishes rates for the sale of electricity and charges for irrigation water. It maintains its own system of accounts, and, while wholly owned by the Government, it is intended to have sufficient autonomy to operate as an independent enterprise. KWPA is to conduct development operations for irrigation and power associated with the waters of the five Khuzestan rivers.

48. D&R has already transferred, and KWPA has accepted, full responsibility for power operations and for general services, although the firm's staff and contractors continue to assist KWPA in carrying out this work. In power operations, the firm entered into a contract on behalf of KWPA with the Hydroelectric Power Commission of Ontario to operate and maintain the Dez hydroelectric project and to train a staff of Iranians later to assume these responsibilities. The Ontario Hydro group serves as part of the organization of KWPA's Power Division, which is headed by an Iranian engineer. Reporting to him is the technical director of the Power Division,

through whom the various elements of the organization now report. He is a D&R employee and also serves as a consultant and advisor to the chief of the Power Division and to other members of KWPA's management. By 1965, it is anticipated that the power operations of KWPA can be entirely handled by its Iranian organization, with the training it will have received.

49. D&R assisted the Government of Iran in its negotiations with the International Bank for Reconstruction and Development, which agreed to lend \$42 million to Iran for the Khuzestan program. The balance of the funds required are being supplied by Plan Organization, from Iran's oil revenues. The total cost of the present KWPA program is estimated at \$150 million. Included are Dez Dam, transmission lines and substations, a pilot-irrigation project, a sugarcane plantation and factory, and rehabilitation and expansion of five electric distribution systems in and near the principal load centers. The loan agreement with IBRD includes provisions for maintenance of rate levels for power and the establishment of KWPA.

50. With the availability, for the first time, of modern reliable electric service, in adequate supply and at reasonable cost, power requirements in Khuzestan have been demonstrated to be capable of rapid growth. The third Dez generating unit is scheduled for installation in 1965-66, and will be needed by then. The fourth is scheduled for 1968. Its actual date of installation can be adjusted to meet any changes from the rate of growth of power needs which is now foreseen.

## Conclusions

51. Securing modern electric-power supply for a particular less developed area requires the solution of many problems which are peculiar to that area. The technical nature of the facilities to be provided, the type of primary energy sources which are available, the existing power systems and their integration, these and more need to be approached for each such area so that their solutions can be tailored to meet the area's needs. In the five cases which have been reviewed, however, there were some problems of significance for the solution of which common avenues were pursued. These common avenues may be of special interest as holding promise for other less developed areas. These problems and their solutions were as follows:

52. *The problem.* To establish an agency with power to exercise sufficient responsibility to carry out the necessary work. No private agency has accomplished this, and no existing agency of Government is set up with the necessary skills and authority.

53. *The solution.* By formal governmental action, usually including actual legislation, to establish key policies and new institutions, separate from the regular administrative departments, although by various methods, responsible to and through the existing structure of Government at some fixed point. There are some especially significant policies for these institutions which appear with frequency:

- (a) They resemble the corporate rather than the governmental form.
- (b) They are intended to be largely autonomous.

(c) They are to have wide flexibility of action and decision.

(d) They are to be largely independent of the regular civil service.

(e) Accountability is assured by prescription of modern accounting practices and regular reporting.

(f) Administration and personnel are intended to be nonpolitical.

(g) They are intended to be financially self-supporting, and to charge the users of their services enough to cover their costs.

(h) They are to be nonprofit.

(i) They are to be exempt from regular taxation, with provision in some cases for payments in lieu of taxes under a specified formula. Except for such payments, none of the agencies can serve as a channel for contributions by electric consumers to the general funds of the owning Government.

54. *The problem.* To finance the cost of construction of the modern electricity supply facilities.

55. *The solution.* With initial contributions from the sponsor or owning Government of cash and property, the new institution finances its costs through (a) its income, (b) its own internal and external borrowings, and (c) through borrowing made or guaranteed by the sponsor Government. In each case, the sponsor Government is in the position of the owner of the equity in the new institution, the new institution being responsible directly or indirectly for defraying the debt service costs. The return on the owner's equity is not ordinarily to be in cash terms, but in terms of benefit to the general welfare.

56. *The problem.* How can the necessary higher skills be acquired rapidly in order to utilize and apply the advanced

technologies involved in providing and operating a modern electric power system?

57. *The solution.* Each case, in its own way, has involved the importation into a geographical area of management, engineering, and labor skills not indigenous to the area. Training programs are then depended upon to bridge the gap between (a) the early organization using foreign skills and (b) the ultimate organization made up largely of local people. Continuing availability of high-level technical and management assistance is obtained through appropriate contractual arrangements.

58. *The problem.* How to integrate existing electric systems into the newly constructed system in such a way as to make optimum use of existing properties and organizations, while moving ahead toward the integrated system with its inherent economies.

59. *The solution.* Most common among the five cases has been the negotiated purchase of existing privately owned systems, and the absorption of existing publicly owned systems, if any, into the new one. Existing organizations are absorbed, to the extent that they can be useful to the new institution, either directly or by retraining. Wholesale power contracts are also used as the vehicles through which the new institution's policies are adopted by local agencies distributing power supplied from the new system. They control retail rates and customer service and accounting policies. This is, of course, not necessary in cases such as PPC and PRWRA, which serve all, or practically all, ultimate consumers in their service areas.

60. *The problem.* How to develop internal and external sources of financing

for the large investments necessary to supplement its own and its owning Government's resources to provide for a modern electricity supply system?

61. *The solution.* In each case the new institution has the power to borrow money in its own name, and has used this power or the borrowing power of its owning Government to secure a portion of the funds required. In each case, also, the new institution has the right to dispose of its revenues for power purposes. The electric-power business can be depended upon to yield revenues adequate to cover its costs. Investors will be willing to advance funds for it at reasonable cost if they are assured that the institutional arrangements will preserve the financial integrity of the business; if, in other words, the credit of the new institution is established and maintained, if it is proven as a "good risk." The private capital markets, within the country or in the outside world are depended upon in some of the cases, others have so far limited themselves to public agencies, still others have used a combination of private and public sources. Supplier credits have also been utilized.

62. *The problem.* How can the magnitude of future requirements be measured, in order to determine goals for the development of the new electric system?

63. *The solution.* The records of actual growth for the five cases throw some light on this question. In each case there was a clean break from past records, when the institutions went into operation. With new objectives as to adequacy of electricity supply, levels of rates, etc., the increases in level of use were far greater than many expected. The most important step was the establishment and implementation of the new objectives.

Then, the provision of new capacity to meet changing future needs could be geared to provide adequate margins. If growth is less rapid than expected, planned expansion can be postponed, if growth is more rapid new facilities can be accelerated. Plans should be made for power-system development which are geared to probable future levels of needs with certain specified timing assumptions. Changes of timing can then readily be accomplished as the facts of future requirements and their rates of growth become available. Initial market predictions can take into consideration basic economic considerations such as population and its growth, and specific industrial development possibilities, as well as experience in other areas when adequate power supply becomes available. The experience in the five cases shows that high rates of growth are probable, and that doubling every 5 years or so can be maintained for extended periods.

64. *The problem.* Determining what role in electric-power supply should be played by indigenous primary energy sources.

65. *The solution.* Emphasis was first placed in all cases upon development of indigenous energy sources, especially water power. Then, as requirements continue to increase, local coal and oil refinery product resources enter the energy supply for the power system. Foreign exchange needs for oil purchases place a premium on the use of other primary sources which may encourage their development, even at somewhat higher economic cost. However, the premium thus paid by consumers of electricity as their contribution toward preserving their nation's foreign exchange balances should be continuously examined with a critical eye to assure that it does not become so

large as to interfere with the accomplishment of the objectives of power-system development. Electricity is a highly flexible form of energy. Technology now has advanced to the point that it can be produced economically through the use of a wide range of primary sources, including, in addition to water power, coal of practically all grades, natural gas, and many grades of petroleum products, ranging from crude oil, through light products to residual fuel oil (Bunker C) and even to refinery pitch which is used by PRWRA directly from the refinery and which is quite economical.

66. With the establishment of public sources of financing such as the IBRD and its affiliates, International Finance Corporation and International Development Agency, the Inter-American Development Bank, the U.S. Agency for International Development, and its counterparts among other Western nations, opportunities have greatly multiplied for less developed areas to secure assistance in financing modern electric-power systems. Consulting and advisory services are widely offered by private and public agencies. And experience in other areas such as the five cases described here is accumulating rapidly.

# *Coal: Mining and Efficiency in Use*

## Practical Application of Coal-Mining Technology to Projects in Less Developed Areas

F. R. ZACHAR

*Mining Engineer, Morgantown, West Virginia*

1. The combinations of methods and equipment to be selected for the successful mining of coal are as numerous as the combinations of conditions and circumstances under which mining is to take place. It is not sufficient to limit "mining" to those phases of an operation which are restricted to the removal of the coal from its natural state within the earth, the term "mining" must include all other related phases of an operation, such as engineering, mining, preparation, financing and marketing. For any problem of any phase there are many theoretical solutions and several practical solutions. The practical solution to any mining problem will vary with conditions, loca-

tion, personnel, markets, and financial abilities, and it can be generally stated that each mining area, and even each mine in any area, should be considered as an individual case when seeking a practical solution to its problems.

2. In the United States of America the productive capacity of the coal industry exceeds the demands of consumers upon producers by upwards of 25 percent, and in the calendar year 1961 the industry, capable of producing well over 500 million tons, produced only slightly more than 400 million tons. This usage-production ratio has existed for the past 4 years and has naturally created a buyer's market and an extremely competitive

position among producers. This situation has been both good and bad for technological advances in the industry. In order to survive, the industry has had to improve its methods, increase the capacity of its tools, and reduce its costs. On the other hand, lowered coal prices and decreased income have restricted cash flow available for recapitalization and acquisition of more efficient and higher capacity tools. However, to the credit of the industry, it must be noted that sufficient method improvements and equipment capacity increases were employed to permit almost a 33 percent increase in tons per man-day in these last 4 years.

3. In most less developed areas of the world the advances in cement, textile, steel, and other industries since World War II have not only increased demand for coal to supply their direct needs, but the expansion has necessitated increased electrical-power generation, and this increased the demand for coal as a source of energy for critically needed steam-generated electrical powerplants. This has created a reverse situation in that the demand for coal greatly exceeds the local output. For example, the Republic of Korea had a need for over 13 million tons in 1960 and had a productive capacity of less than 6 million tons. Under these circumstances, technological improvements in methods and tools are necessary to attain needed production volumes to benefit economies beyond those of the coal industry alone. Or, production of coals with special qualities are needed to permit other industries to be developed, and improved methods and tools are needed to permit expansion of the coal industry into the production field for these coals.

4. It must be realized then that, while the coal-industry problems of a nation under development are somewhat similar,

they vary somewhat from the problems of an individual mine or company in that nation. Without attempting to list herein all objectives of an improvement program to develop mining technologies for each, we can set out certain main objectives for a national coal policy and for an individual company policy, recognizing that there are some overlaps.

5. The problems of each nation producing, or capable of producing, coal are separate and distinct, but it is generally true that all have two problems in common. These are the need for more coal to aid rapidly developing national economic programs and the need to provide expanding power and other industries with a locally produced source of energy in order to avoid foreign-exchange expenditures for imported solid fuels. The importance of these problems can very well often dictate the mining of coal under seam conditions and of qualities that, under other circumstances, would be considered economically unminable or unmarketable.

6. It is also quite likely that, in many countries, the replacement of any great percentage of people currently employed in mining with mechanical production or preparation equipment may induce an employment problem quite serious to local areas. This paper will not attempt a discussion of this problem, but the scope of any program whereby new methods and tools are to be utilized could be affected or governed by consideration of this possibility, and the degree of mechanization elected limited to its utmost practicality.

7. The problems of individual mines and companies vary with the degree of public ownership. Mines operated one hundred percent by governmental agencies and financed wholly with govern-

ment funds are usually somewhat free of the risk of operating failure. This is particularly true where major coal-consuming industries are also government-operated and where coal prices and freight rates are fixed by government regulation. It is not uncommon to find such mines producing their objective tonnage or supplying needed quality coals to rapidly developing coal-consuming industries and thus fulfilling their place in the nation's economic-development program, but doing so at a per-ton mining cost above that of their per-ton income. After proper study and evaluation of the needs of these mines, programs requiring expenditures to bring about method changes and use of modern tools and machinery are usually able to be adopted without excess financial burdens being placed upon the operations, by items such as down payments, interest, and amortization schedules. This is of utmost importance in that it more readily gives those responsible for attempting to introduce up-to-date mining techniques a certain freedom for experimenting and for trial-and-error procedures without the dangers of having first-effort failures condemn the programs or cause them to be abandoned prematurely, for financial rather than technical reasons.

8. Mines operated by private companies and financed by private capital have one all-important problem over and above those of government-operated properties with identical mining conditions and preparation requirements. That problem is that the results of expenditures to improve methods and tools must result in an immediate or early operating profit, or, in other words, any expenditure must either contribute to a reduction in mining costs or contribute to increased income sufficiently to more than pay for the cost

of the installation over a reasonable period of time and to more than pay for any financing charges for money borrowed to make the expenditure. Certainly, government-operated mines are intended to operate at a profit and all efforts are usually made to accomplish this, but private mines or those operated with private funds absolutely must operate at a profit. For the purpose of this paper then, in discussing the practical application of coal-mining technology to mines anywhere, we will consider that the prime object of any modernization program is to permit the mines being modernized to produce more coal more efficiently, and to show a profit for the owners, either public or private, in doing so.

9. Coal mining is basically a science of material handling and the successful operator is one who can move a large volume of material from its natural place within the earth to a railroad car, truck, barge, or stockpile on the surface, and who can utilize the labor and machinery available with a degree of efficiency to permit mining costs to be sufficiently below the selling price of the finished product to justify the investment of whatever capital has been allocated to the mine. The methods and procedures that are employed in actually removing in place material from the face, the drainage and water-removal methods, the distribution of necessary electrical power to operate face and surface equipment, and the methods used to transport broken material from the face to the point of shipment or point of processing are, while considered generally in the science of mining, mainly and basically components of a material-handling program. The methods and tools employed to support the roof, to ventilate the mine, or to crush, size, or wash the raw coal really make up

the portion of the job of mining that can be classified as peculiar to the science of mining.

10. The mining industry differs from manufacturing or the processing industries in that no two mines have the same physical conditions and operating problems. While it is possible to make general statements and draw general conclusions that will apply to the industry as a whole, it is not fair to evaluate present methods nor practical to estimate results of potential methods of any one mine unless that mine is carefully studied and its individual problems and needs determined.

11. It has been the writer's experience, over quite a few years of association with coal mines, large and small, in the United States and overseas, to learn that mining people in one place are generally as intelligent and competent as those of other areas, and that there are usually good reasons for the methods currently being employed at any mine even though those reasons may not be immediately apparent to an engineer examining the property and not completely familiar with all of its problems. This fact, sometimes overlooked, is very important, and failure to recognize this can lead to very costly misapplications of methods and machinery. It must be remembered, when discussing the application of advanced coal-mining technology, that even in coal fields in the United States where mining has been carried on for many, many years and where it would be supposed that all there was to learn had been learned, it is not uncommon for method changes, machinery purchases, or preparation changes to fail to meet their expected results because of failure to evaluate properly all aspects of the problem prior to application of new

methods or machinery. Certainly the fact that the tons-per-man shift of the industry has been doubled during the past eleven years attests there having been more successful applications than failures, but it is also true that misapplications have occurred and will occur in the future due to this engineering shortcoming. By the same reasoning, it cannot be expected to have one hundred percent of recommended method changes and one hundred percent of recommended machinery applications in other countries result in improved production, costs, or coal quality. It is possible though, for those offering technological counsel, by full utilization of the experience of those local people familiar with local problems, and with their own knowledge of improved methods and available tools and machinery applicable to the particular situation, to introduce different methods and different or more applicable machinery that will accomplish the desired objective in a very high percentage of cases.

12. Space allotted this paper does not permit a description of the countless mining methods that might be applied to the countless different set of conditions existing in coal fields over the world. Nor does space permit description of the innumerable devices and machines available and applicable to the various conditions and problems of the world's coal-mining fields. It is believed, however, that proven methods, or variations thereof, and applicable machinery for nearly every condition exists, and that the output and efficiency of any coal property can be improved by acquainting those operating the mine with these methods and tools, and helping those in direct charge with the adoption of the methods and application of the machinery ultimately selected.

13. "Coal mining technology" not only embodies the highly technical aspects of the art, but covers financial considerations and general know-how of all of the many factors contributing to the removal of solid-in-place material from the earth and handling it through successive stages until a desired finished product has been delivered into the transportation medium for delivery to ultimate consumers, and the so-doing has resulted in an economic gain for the producers. It is, therefore, pertinent that we discuss herein the major nontechnical, but all-important, factors that must be considered when making a practical approach to the introduction of new or revised mining methods and the introduction of more applicable machinery to coal mines in an area previously not having had the advantages of experience with mechanized operations. It is naturally assumed herein that the mining area considered for modernization has personnel available who are not only experienced in their field but are cognizant of their production and quality needs and who are aware of the fact that there is a combination of methods and tools, proven successful under conditions approaching or similar to their own, available for adoption to their needs. It must also be assumed that proper study has indicated the need for either increased production and/or lower costs and that the modernization project, if successful, can show practical benefits to the area. Some of these factors, all important to the application of advanced coal-mining technology, are:

#### **Financial and Investment Policy**

14. To be a success, in normal circumstances, an investment in method change or machinery must return benefits to the

investor in forms of lower production costs, increased sales revenues, increased production, increased coal reserves, high recovery of reserves, greater safety of operation, or other worthwhile benefits. In addition, expenditures for machinery must be able to earn a minimum over present earnings sufficient to permit their being amortized over the period of their useful life, as well as earn enough to pay the interest if purchased with borrowed money to justify the expenditure. If amortization costs plus interest on an expensive piece of machinery exceed the reduction in mining costs possible with that machinery, the utilization of that equipment is not practical, regardless of theoretical correctness, unless the national economy receives benefits not apparent from the coal mine's cost sheet.

15. If foreign-aid funds are used to finance expenditures for equipment for private mines, it is certainly necessary to definitely determine whether these funds are available from a saleables program, from grant type assistance, from project type assistance, or from development loan fund help. It is entirely possible that large expenditures provided for from funds from the wrong source can cause economic hardships that outweigh the benefits anticipated from the equipment.

#### **Anticipated Machinery Usage**

16. Machinery should be recommended that will operate the maximum practical hours per day in order to reduce the cost per ton for the use of the machine. Simple arithmetic points out that the use-cost per-ton of a machine operated two shifts per day will be only 50 percent of the use-cost per-ton over its amortized life of the same machine operated only one shift per day. This is extremely impor-

tant when high-cost machines are to be used under unfavorable conditions and less-than-capacity tonnages are produced.

### **Maintenance of Machinery**

17. The ability of the operating people of an area not privileged to have gained experience in maintaining complicated mining equipment to keep machinery in repair and producing must be considered when selecting equipment for that area. It is not at all practical to recommend or furnish a mine with equipment that will be extremely difficult to maintain and keep operating. It is very easy to say "if a mine in the United States can operate and maintain this equipment, we can do it over here," but it must be remembered that the highly successful mechanized mines of the United States are manned by people who have been working with mechanization programs since the use of mechanical equipment first gained prominence.

18. It must be kept in mind that the more complex machinery requires a much greater inventory or near-at-hand source of repair parts. The writer's experience in certain areas of Southeast Asia indicates that often it is not possible to obtain critical parts and that, ingenious as the mine personnel may be, substitution of domestic made parts is not always possible and long and costly machine outages result. Machines selected for use in areas where repair parts are not readily available might well be selected for their ruggedness even at a sacrifice in productive capacity.

19. A very important practical contribution to a program of introducing modern mining technology to areas accustomed to the use of simple hand tools would be the provision of training facili-

ties where mine personnel could learn and become acquainted with the rudiments of basic mining machinery maintenance requirements. While it is true that a few people, usually company officials, from these areas are privileged to visit mines in countries where mine mechanization is well-advanced, it is the writer's thought that more people who are actually going to be required to keep the new machinery operating should be trained in basic fundamentals prior to the introduction of expensive, relatively complicated mechanical equipment.

20. Another practical step in introducing mechanization to areas previously utilizing little or no machinery would be the encouraging or actual establishment of nearby sources of supply for critical electrical and mechanical repair parts. The success of many American mines depends a great deal upon the ability of mine-maintenance people to pick up a telephone, call for a part, receive quick delivery, and get the out-of-service production equipment back to work with a minimum of lost time.

21. In the early stages of any mine mechanization program it is quite practical to standardize equipment as much as possible. Fewer types of machines means fewer things to be learned, and, generally, mine-mechanization programs will enjoy earlier and more continued successes than if mine personnel are burdened with the task of understanding a wide variety of basically different machines. The benefits of standardization will more often than not be greater than those actually derived from a wide variety of theoretically more efficient and higher capacity machines. Quite obviously standardization will facilitate maintaining a supply of repair parts and will contribute to the reduction of necessary parts inventory.

## Industrial Engineering

22. In the United States it is rapidly being recognized that the coal industry has gone along too many years depending on good natural conditions and availability of machinery for its success in reducing production costs. It is interesting to note that during the period 1950-1960, even though tons-per-man shift of the bituminous industry increased from 6.77 to 12.83, the direct cost of labor, supplies, and power in a typical coal-producing area decreased only from \$3.07 to \$2.94 per ton. In the same 10-year period, however, the average selling price of coal at the mine decreased considerably more than the \$0.13 per ton reduction in direct cost and per-ton profits decreased despite an increase of almost 90 percent in labor productivity. This loss of profit curtails available cash flow and the industry is no longer able to continue the high-capital dollars-per-ton expenditures for more productive machinery. Rough estimates indicate that in 1951 capital expenditures of the bituminous industry amounted to about \$0.60 per ton of coal produced, while in 1960 capital expenditures amounted to only about \$0.25 per ton of production. Certainly the cumulative effects of heavy mechanization programs, the advent of larger and more productive equipment after World War II, and the fact that continuous mining came into its own in the above 10-year period, were responsible for a large portion of the tons-per-man shift increase. However, a considerable portion of the tons-per-man shift increase did come from the industries devising better and better methods and systems through industrial engineering, and with capital flow reduced to an extreme low, the industry will have to depend more and more upon its ability to

devise better methods if the present profit margins are to be maintained or improved. The industry is therefore turning more and more to industrial-engineering practices to improve costs.

23. There would seem no better time to acquaint mining men with the objectives, methods and procedures, and potential of good industrial-engineering practices than prior to and during the investigation period leading up to the introduction of new methods and equipment. A practical industrial engineering program can very well begin with the gathering of information on all phases and aspects of the present methods employed and an analysis of where those methods could be improved. In many areas of the world men are carrying on mining methods handed down from father to son from ancient times and people are doing things a certain way because they have always been done that way. Experience has shown that, once aroused, man's natural curiosity will lead him to discover a better way to do almost anything, and an industrial-engineering approach to the study of an area's present methods seems to be the most practical and purposeful method of arousing that curiosity.

24. When the mining personnel of a mine in an area employing less than efficient methods and utilizing relatively simple tools and equipment have been made aware of the shortcomings of their systems through their own studies, the problem of selecting corrective methods, systems, and equipment becomes greatly simplified. A presentation of as many as possible of available choices with sufficient data on results attained elsewhere under somewhat similar conditions should lead to an agreement among all concerned as to what methods and what

machinery is most likely to succeed with their mining conditions and product requirements. Any change in methods or machinery selected in this practical manner will have an excellent chance of succeeding from the beginning.

25. It has been the writer's experience that it is impossible to select a "best" method of mining for any complement of equipment until the equipment has actually been installed and a study made of the system employed. Certainly all available knowledge and experience should be compiled to select what seems to be the most appropriate methods and projections for new mining equipment, but it will be only through actual study of the equipment at work that the final and best methods or projections can be ascertained. Experience around the mines has shown that no matter how carefully and thoroughly a new mining system or projection has been worked out on paper, the first few days' actual trial will indicate necessary changes and improvements. This is true primarily because mining, unlike most manufacturing and processing industries, is not a set of repetitive operations even though mining cycles are usually made up of the same major steps. No two working faces will be undercut, drilled, shot, loaded, or timbered exactly alike, and each place requires individual consideration and planning to insure the most efficient accomplishment of each portion of the mining cycle.

26. Close observation over the first few days of operation under a new system or with new and different equipment will bring out the major shortcomings of the plans and will forcibly point out the factors that were overlooked in the planning stage. When these major corrections or changes to the original plan have been made, it is then most appropriate

and beneficial to all concerned to begin gathering performance data with time studies. It is the writer's earnest opinion that the use of time studies is one of the most practical and necessary steps in the successful introduction of new mining methods or unfamiliar mining machinery to coal miners in areas where modern machinery and methods of using that machinery are relatively strange.

27. It has often been said that the time-study man himself usually learns more about the operation being studied than does anyone else. This seems to be true, and, if at all possible, those people who are to become supervisors and in charge of making any new methods or machinery successful should do a great deal of the actual time study work. In doing so he has an opportunity to form his own opinions, substantiated or proven wrong by his own detailed study, and from this first hand practical method of training, he will usually become a better supervisor in a shorter length of time.

### Service Operations

28. No mining plan or machinery can produce its optimum at the face unless it is backed up by a good reliable service organization. While it is usually the face or production operations that receive most attention from management, the behind-the-scenes service functions at a mine are equally important and deserving of close study and attention. One reliable statistical source points out the following actual relationships in the bituminous industry of the United States between production labor cost and service labor cost in 1950 and 1960, and the estimated relationship in 1970 if technological improvements in present equipment and mining systems continue as expected.

	Percent of total labor cost	
	Production	Service
1950.....	56.5	43.5
1960.....	50.0	50.0
1970 (estimated).....	40.5	59.5

29. It is quite understandable why mining people are more apt to devote more time and research to improving production labor costs since it is the production crew that supports and makes possible all other operations at the mine. However, it is becoming more and more important to have service functions perform with high efficiency if total production costs are to be reduced to necessary lows. In a mining area where a program to train people in modern methods and where new mechanical equipment is being introduced, it is most practical to analyze each mine's over-all problems and to endeavor to improve the service functions along with the production methods.

30. One of the most important problems of any underground coal mine is that of controlling the roof. Regardless of where the mine is, or what the seam height is, or whether the seam is flat lying or pitching, face production equipment, even in a theoretically perfect system, will not perform up to standard if the mine roof is bad beyond control or neglected and allowed to be bad. A very thorough study of roof control possibilities should be made prior to the selection of production equipment or methods in an area where little or no experience has been gained in supporting the roof for mechanical mining. For the most part, introduction of mechanical mining equip-

ment requires driving wider places, making larger place intersections, and more free unobstructed working area within working places. These requirements more often than not make it mandatory that an entirely new concept of roof support be adopted.

31. Those in charge of introducing coal mining technological improvements in areas of the world where mining conditions are difficult and where only relatively simple hand mining methods have been practiced over the years would do very well to insure that practical roof control methods are possible with recommended machinery and methods. For instance, while we here in the United States take it for granted that roof bolts are readily available at a reasonable price, there are areas where the requirement of almost unavailable roof bolts could make a theoretically good mining plan unworkable. Each area will have different roof control problems and, since roof control success will generally limit all other production successes, these problems must be solved in the most practical manner and cannot be ignored.

32. No mining system or any combination of modern face machinery can produce more coal than can be transported away from it. Consequently the mine haulage system must have a greater capacity than the production equipment. This fact is basic and practical consideration must be given to storage facilities, proper complements of cars and locomotives, or properly selected conveyors to enable any improved systems or improved face equipment to surpass or even reach its expected performance. Since each mine in each area will have different haulage problems, each mine's objectives and possibilities should be analyzed thoroughly prior to, or along with, the

study of face production needs. It is most embarrassing to install extremely high-capacity face equipment and to plan a well-engineered mining system, and then come to the realization that the new equipment is able to work only a fraction of the available time due to transportation shortcomings. It must also be remembered when selecting mainline haulage systems for new mines that the system will have to be extended from time to time, and may finally cover a distance of several miles. The fully extended cost should be considered and the life and replacement cost given practical consideration when choosing between rail and belt haulage.

33. The availability of electrical power, both to the mine and to the working faces of the mine, must be carefully considered when planning the use of larger or new electrically powered production, haulage, or preparation equipment. Thorough and complete studies must be made to insure proper functioning of any equipment selected to improve hand mining or hand cleaning methods. Inadequate voltage can result in substandard performance of machinery and in costly armature and related electrical failures. Where a mine does not have adequate power available, it would be much more practical to utilize equipment of less capacity successfully than to attempt to use high-capacity equipment and fail due to inadequate power.

34. Where hand mining has been the practice it is usually found that the miners do a good job of loading coal relatively free of impurities. It must be recognized that the raw coal from mechanical equipment will contain a much greater percentage of impurities, with the expected percentage depending somewhat on the machinery used. Also, where hand min-

ing usually produces a fairly large percentage of coarse coal that can be hand picked to satisfaction, mechanical mining, and continuous mining in particular, usually produces a much greater percentage of fine coal that is difficult to beneficiate. The detrimental affects of mechanical production on the raw coal at each mine will be somewhat different due to seam characteristics, type of equipment, and market requirements. It would be extremely impractical to install machinery of high-capacity production but which would not produce a product satisfactory to the market.

35. Preparation techniques have been developed to a high degree during the past 10 years and it can be said that there is equipment available for any coal-beneficiation problem. Practical preparation improvements, however, should be limited to those which enhance the quality of the finished product to the maximum consistent with added benefits to the consumer. A thorough understanding of preparation needs and a close scrutiny of alternatives available should precede the introduction of mechanical-preparation facilities. Those not experienced in the economics of coal preparation can very easily be carried away by the thought of improving the ash or calorific value of their finished product and then learn, after their plant is in operation, that their reject losses and total cost of preparation exceed the gains in revenue due to having a premium-quality product. Simplicity of flow, minimum of handling, and maximum flexibility should be the object of plant selection after it has been definitely decided that a plant is needed.

### Conclusion

36. As stated earlier herein, it is generally true that coal-mining people in

one area of the world are as intelligent and competent as those elsewhere. Some areas, however, have not had the advantages of watching, and participating in, the growth and development of their industry from hand mining to almost fully mechanized mining methods. In many cases these areas are taking technological steps that required decades in the United States and, while desire for success is great and while theoretical knowledge has been acquired, the actual introduction of modern coal-mining methods and the use of modern machinery must be undertaken with utmost respect for the lack of practical experience at hand. Such things as the availability of parts, availability of power, totally new roof control concepts, available repair shops,

etc., things taken for granted in areas having years of experience with mechanized mining, must be given the greatest consideration if new methods and equipment are to be applied on a practical basis.

37. It is firmly believed that coal-mining or coal-preparation methods of any nation in the world can be improved by the practical application of one or more of the methods and/or one or more of the machines or tools proven successful in the technological development of the industry in recent years. No condition or objective should be considered impossible with the great number and wide variety of methods, tools, and machinery available for its practical solution.

---

# Metallurgical, Domestic, and Industrial Utilization of Low-Rank Coals\*

W. S. LANDERS

*Chief, Denver Coal Research Laboratory, Division of Bituminous Coal, Bureau of  
Mines, U.S. Department of the Interior, Denver, Colorado*

1. The proper utilization of coal resources is an important, and possibly essential, step in the advancement of less developed areas of the world. Coal is a widely distributed mineral, usually comprising a significant potential source of energy and chemicals where the reserves of coal are adequate and where it can be economically mined. The low-rank coals of the world are widely distributed; but their utilization, particularly in expanding economies of the less developed areas, has been restricted, because of their chemical and physical properties. Low-rank coals for the present purpose include brown coals, lignites, and subbituminous coals, corresponding to classes 10 through 15 of the International System for classifying brown coals and lignites. They are all characterized by high-moisture content, a relatively low heating value, high-oxygen content, inability to fuse to produce coke, and high susceptibility to spontaneous combustion during transportation or storage.

2. In less developed areas of the world, the major historical use of low-rank coals has been as fuel for local consumption. Even this restricted use, however, has

been difficult in many areas because these coals cannot be burned successfully and easily in equipment used with wood, charcoal, and other traditional fuels. The purpose of this paper is to present and discuss techniques applicable in these areas that would permit the extension of the use of such coals as technologic and industrial development progresses. Within the space limitations of this paper, it will not be possible to do more than suggest or mention many of the possible areas and techniques of utilization. It is my intent, however, to show that widespread application can be made of such fuels through the use of technologies and information now available.

3. Coal utilization may be discussed best under several general categories. I have chosen to emphasize the application of low-rank coals to iron-ore reduction because of the widespread international importance of metallurgy and the projected expansion of the steel industry in the less developed areas of the world.

4. Since prehistoric times, metallurgical operations have used charcoal or anthracite as a source of heat and as a chemical reducing agent. These fuels, however,

---

\*U.N. Conference paper.

are too costly or do not possess the proper physical or chemical properties for use in modern, large-scale metallurgical operations. As the need for stronger, cheaper, and more uniform fuels developed for these applications, the metallurgical industry concentrated in those areas of the world having coking coals. Small local metallurgical industries persist to this day in countries not so fortunately endowed, but such installations are not adequate to serve the needs of an expanded industrial economy.

5. The most intriguing, useful, and desirable metallurgical application of coal in our present economy is in the production of pig iron. The blast furnace is used almost universally, in one way or another, to produce this material. Because of the requirements of the blast furnace, the fuel supplied to modern units is a strong, hard coke, containing low concentrations of water and volatile matter. Low-rank coals do not possess the property of directly fusing in the coke oven to form such a coke. If they are charged in their natural state as a coke substitute, the blast furnace cannot function because the coals, in addition to having a high-volatile-matter content, will crumble and clog the passage of the air blast. However, recent developments have demonstrated two processes by which pig iron can be produced with noncoking coals. The first of these is the modification, through suitable processing, of the low-rank coals to form a synthetic coke that can be charged as part of the burden in conventional or modified blast furnaces. The second approach is the utilization of metallurgical techniques not requiring the use of the blast furnace. It is not the purpose of this paper to discuss the relative merits of these two

techniques, as the choice between them transcends technologic consideration.

6. The production of synthetic coke by modification of low-rank coals consists basically in changing the chemical structure of the coal to reduce its moisture, oxygen, and volatile-matter contents, to increase its fixed-carbon content and heating value, and to consolidate the modified coal into a strong, dense agglomerate. The FMC Corporation and the U.S. Steel Corporation, both of the United States, have recently developed and announced a process to accomplish these results. This process, generally known as the "FMC Process", consists of the following steps:

(a) Stage crushing of the coal to less than  $\frac{1}{8}$  in. (3.2 mm).

(b) Preprocessing of the crushed coal by controlled oxidation at a relatively low temperature in a fluidized bed in order to modify both chemical and physical nature of the coal.

(c) Carbonization of the modified coal in a fluidized bed to produce a low-temperature char (semicoke) and sufficient condensable tar for use in the subsequent briquetting operation.

(d) Production of a low-volatile char by recarbonization of the low-temperature char at high temperatures in a fluidized bed.

(e) Briquetting of the high-temperature char with the entire output of low-temperature tar in conventional, high-pressure, opposed-roll presses.

(f) Controlled oxidation at moderate temperatures in a shaft furnace to modify the chemical nature of the tar binder.

(g) Recarbonization of the modified briquets at high temperatures to produce a strong, low-volatile matter bri-

duct suitable for blast furnace and other metallurgical applications.

A comparison of the physical properties of large-size FMC Process briquets and similar properties of conventional foundry coke is given in table 1. The

FMC briquets may be made in any size, and it has been indicated that reactivity and other properties of the briquets can be controlled by selection of temperature, residence time, and other operating variables.

TABLE 1. *Physical and chemical properties of FMC Process and foundry cokes*<sup>1</sup>

	Coke from FMC process	Foundry coke
Shape.....	Uniform pillow blocks	Random.
Size.....inches..	As desired, up to 3½ x 4	Random, up to 4 x 8.
Moisture.....percent..	1-2	1-2
Drop shatter index.....	92+	92+
Tumbler index.....	92+	92+
Crushing resistance.....psi..	3,000-6,000 <sup>2</sup>	2,000-4,000 <sup>3</sup>
Apparent specific gravity.....	1.0-1.05	0.95
True specific gravity.....	1.95	1.95
Bulk density.....lb ft <sup>3</sup> ..	38-42	28-32
Proximate analysis, moisture-free basis, percent:	( <sup>4</sup> )	( <sup>4</sup> )
Volatile matter.....	2-3	1-2
Fixed carbon.....	92-95	88-93
Ash.....	3-6	5-10
Sulfur.....	0.5-0.8	0.5-1.0

<sup>1</sup> Data supplied by the FMC Corporation, New York, N.Y., U.S.A.

<sup>2</sup> Based on cylinders of one-square-inch cross sectional area.

<sup>3</sup> Based on ½-inch cubes.

<sup>4</sup> Analyses shown are typical. Actual values depend upon ash and sulfur content of the coal used.

7. Brown coal and lignite have effectively been converted in various parts of the world to materials suitable for use in low-shaft furnaces. Many of these low-rank coals are briquettable in high-pressure equipment without the use of binders. This technique, where applicable, requires crushing and drying of the high-moisture lignite or brown coal to a preestablished optimum moisture content, briquetting in high-pressure equipment, and carbonization of the briquets to high temperatures to produce a low-volatile coke. The heating schedule for the carbonization is critical, but an excellent product can be obtained by this technique. For those lignites and brown

coals not briquettable without a binder, briquets can be produced from either the dried or carbonized coal using pitch or other binders. Such briquets are usually carbonized to produce a low-volatile, hard coke. If high-density fuels are not required, it is possible to pelletize coal with suitable binders and to carbonize the pellets by a carefully controlled heating schedule in a stream of hot natural gas or methane. This treatment sets the aggregate into a strong coke-like structure.

8. The other major approach to the utilization of low-rank fuels in the production of pig iron involves the use of techniques not requiring the blast fur-

nace. There are a variety of such "direct reduction" processes that have either been tried or suggested, but most of them make use of an inclined rotary kiln into which a burden of ore, flux, and solid fuel is charged. As the burden moves through the kiln, some of the fuel burns in the air blast introduced at the discharge end to produce the heat required for the reactions; the remainder of the fuel then acts as a chemical reducing agent to produce metallic iron (or partially reduced iron oxides) from the oxide ores. There are many variations possible in this approach. For example, some processes produce a molten slag of vitreous material in which the iron particles are suspended. The slag issuing from the kiln is quenched and crushed, and the iron particles are collected by gravity separation or by magnetic means. In other processes, the kiln is operated under nonslagging conditions producing either finely divided metallic iron distributed throughout the nonfused product, partially reduced iron ore, or a mixture of the two. It has been successfully demonstrated that char or semicoke made by the carbonization of low-rank coals is a satisfactory fuel for use in direct reduction kilns. These chars, generally produced in entrained or fluidized beds, are highly reactive, and if formed at the proper temperature, they do not produce any objectionable tars or liquids that could affect the operation of the necessary dust-collecting apparatus used at the gas-discharge end of the kiln. It has also been demonstrated that raw lignite can be used efficiently as the reducing agent in at least one of the direct-reduction operations. It is likely that, through suitable modification of operating techniques, raw, dried, or carbonized lignite, brown coals, and subbituminous coals can

be used in a variety of the direct-reduction processes.

9. The use of low-rank coals in the production of pig iron can be accomplished, then, through either the radical modification of the coal to produce a synthetic cokelike material that can be used in the blast furnace or the application of direct-reduction kilns with either raw or modified noncoking coals as the fuel. The choice between these two approaches is an extremely complex one, depending upon quality and physical structure of the ore, as well as upon economic and other technological considerations.

10. Other metallurgical processes, such as scrap melting, slag reprocessing, and reduction of nonferrous metals, can utilize the coke substitutes prepared from the low-rank coals. These coke substitutes can also replace coke in other industries; for example, FMC Process briquets have been used in electric furnaces producing elemental phosphorus.

11. Sources of adequate fuel for domestic heating and cooking are becoming increasingly important problems in many of the less developed areas of the world. The fuels frequently used in these areas are wood, charcoal, and dried dung. The source of wood and charcoal has been the forests contiguous to centers of population, and a natural balance has been effected over the centuries between the use of the wood and the rate of growth of the forests. In recent years, however, such balances have been upset in many places by the rapidly increasing population. The forests are being depleted, the source of wood is receding from the population centers, and the cost of wood or charcoal is increasing rapidly. Raw low-rank coals can be used effectively for cooking and heating; however, it is necessary to have stoves and furnaces specifi-

cally adapted to the burning of high moisture solid fuels. Such equipment is not readily available in the less developed areas of the world. In addition, there are established techniques of cooking and heating based upon the traditional fuels available in these areas. Eventually, it might be possible to modify the habits of the inhabitants of these areas so that the coals can be burned directly in proper stoves and furnaces, but this will be a slow process. The better solution, and one more likely of immediate acceptance, is to modify the low-rank coals by processing so that the resulting products can be burned in braziers and other existing equipment in the traditional manner.

12. Let us examine the properties of the traditional fuels and compare them with the equivalent properties of the low-rank coals. Wood is an easily stored, easily ignited fuel requiring no special equipment for its handling or use. When it burns, however, it produces a smoky flame with an acrid odor. As a consequence of this smokiness, the practice has developed in many villages and towns of burning charcoal. Charcoal is also an easily ignited, handled, and stored fuel. It burns without odor or smoke and is well suited for use in populated areas and in kitchen stoves not equipped with flues or smoke stacks. Dried cow- or water-buffalo-dung is easily stored and ignited. While it burns with a distinctive odor, it does give a smokeless flame and is an extensively used fuel. All three of these fuels are easily handled and consist of relatively large-size particles that can be burned in simple equipment with little difficulty in providing adequate draft. When the immediate use is complete, the remaining fuel can be extinguished with water, allowed to sun dry, and later re-

ignited and used until it is completely consumed.

13. The low-rank coals, on the other hand, are characterized by high moisture content. Lump low-rank coal will slack and degrade to fine sizes or powder as the natural moisture in the coal evaporates if it is stored by simply piling or stacking. The resulting powder, or dust, is not suitable for burning in braziers. If the coal lumps are charged while they are fresh, that is, with their full moisture content, they are very difficult, if not impossible, to ignite in such equipment. As the lumps become heated in the fire, they dry and disintegrate, producing powder which chokes the fuel bed and prevents combustion. It is almost impossible to quench and recover unburned lumps from a fuel bed prepared from low-rank coals.

14. The problem, then, is to convert the coal into materials having properties as similar as possible to the preferred fuels. The general approach is to briquet the coal. Some of the low-rank coals can be crushed, dried to an optimum moisture content of about 10 to 16 percent, and briquetted without binder in high-pressure extrusion presses. The resultant briquets are then carbonized, converting the coal into a smokeless, easily ignited, free-burning char or semicoke briquet. The carbonized briquets are relatively porous and are reactive enough to be ignited by the same procedure used by the housewife for igniting charcoal.

15. If the coal cannot be briquetted without binder, an additive must be used to provide the cohesiveness necessary to form briquets. Such coals are carbonized to eliminate moisture and reduce the volatile-matter content, and the char is briquetted with a suitable binder. Starch, molasses, kraft paper waste, port-

land cement, clay, and other binders have successfully been used for this purpose. Excellent binders are pitches and asphalts. These latter materials coke when heated and form an extremely strong matrix, giving coherence to the briquet in the fuel bed. However, they burn with a smoky flame, and it is generally preferable to recarbonize these briquets before use in open domestic appliances. The problem of odor occurring during the burning of carbonized coal briquets made from char and tar has become important in the United States because of the use of such briquets for outdoor cooking. One of the major producers of carbonized coal briquets in the United States has effectively eliminated such odor through proper cooling of the char and briquets, and by the addition of small quantities of additives and catalysts. These briquets are finding wide acceptance as a premium domestic fuel.

16. One of the largest and most important uses of coal in the less developed areas of the world will probably be in thermal power plants. It has been adequately demonstrated that any of the low-rank coals can be burned efficiently in modern equipment, and the use of coal is primarily determined on the basis of economics. Small power plants can burn the coal on spreader or traveling-grate stokers, or the coal may even be hand-fired. Larger plants will probably use pulverized fuel burners. High-moisture coal must either be partially dried or very finely ground before it enters the pulverized fuel burners. The modern approach is to partially dry the coal, either by using hot-gas-swept pulverizing mills or by predrying the coal before pulverizing. Large power-generating plants in the United States using lignite with 35- to 45-percent moisture as the

fuel are operating successfully with each of these drying schemes. Pulverized-fuel burning is also successfully employed on brown coal and peat in other parts of the world. Processes and techniques for drying the low-rank coals to any predetermined moisture content are well developed and are available in any capacity.

17. The coal-burning gas turbine offers another route by which the low-rank coals can be used for power generation. Extensive pilot plant research is being conducted in several laboratories on the development of this technique. The coal-burning gas turbine will be able to generate power with the consumption of far less water than is required for the conventional thermal-electric plant, a feature of tremendous importance in arid areas. It should be kept in mind, however, that the coal-burning gas turbine is still in the process of development. The main problem yet to be solved is the development of a unit that will perform for long periods of time between outages for other than routine maintenance. The research being conducted in this field should prove productive, and it is believed that an extremely reliable unit will be developed. When this is an accomplished fact, it will be possible to make a rational economic analysis of the application of the coal-burning turbine for a particular installation. It should be pointed out that factors other than the savings in water are of significance in the selection of power-generating equipment.

18. New developments in the transportation of energy may influence the location of coal-burning thermal-electric plants and the economics of their operation. While these developments will probably be discussed in detail by the specialists on power generation, it is felt that attention should be called to sug-

gested techniques that could extend the economical utilization of coal. These include pipeline transportation of coal-in-water or coal-in-oil slurries, improved and more efficient equipment and procedures for rail transportation of coal, and extra high-voltage (over 400 kv ac or about 375 kv dc) transmission of power. The cost of delivering the coal to the power plant and of delivering power to the distribution center are significant factors in determining the economic position of coal-burning thermal-electric plants.

19. In many parts of the world, coal historically was the main source of railroad fuel. In recent years it has been supplanted to a large extent by diesel fuel. This change in fuel supply has been dictated almost entirely by economic reasons. In those countries having adequate reserves of cheap, low-rank fuels, and where coal can be produced at a lower energy cost than diesel fuel, a definite area of application for railroad use exists. Because of the properties of low-rank coals, it is usually unsatisfactory to charge raw high-moisture coal to the firebox of a locomotive. With the high-temperature and high-draft conditions found in the firebox, the high-moisture coals break down into small particles and a large percentage of the fuel is lost up the stack. This obviously presents serious problems of economy and nuisance. It has been found, however, that briquets made from such coal are very satisfactory for railroad use. The type of briquet used is determined by the properties of the coal. For example, some high-moisture coals can be partially dried to 10- to 16-percent moisture content and briquetted without binder. Such briquets are excellent fuel. For this application it is not necessary to produce a smokeless briquet as was the

case for domestic cooking, because the draft conditions in the firebox will burn most of the volatile matter. If a binder is required, satisfactory briquets for railroad use can be made by briquetting the dried or carbonized coal with a pitch or asphaltic binder. When such briquets are charged into the firebox, the hydrocarbon binder decomposes and forms a coke matrix, binding the coal fines into a lump-like structure.

20. Low-rank coals can be used in a variety of special industrial applications. Possibly the most significant of these to the less developed areas is the use of such fuels for cement burning. In order to efficiently burn cement clinker, it is necessary to develop a temperature of at least 3,000° F (1,650° C) in the kiln. Because of the heat required to evaporate water from high-moisture low-rank coals, it is not possible to develop the necessary temperature with these coals unless costly and complicated airpreheating devices are used. If these coals, however, are dried before being pulverized and charged to the burner in the kiln, a flame temperature high enough to burn clinker can be obtained. This technique permits the substitution of low-rank coal for higher rank coal or other fuels for this very important application. The drying of coal in the large quantities required for cement burning can be accomplished economically, in existing equipment. The upgrading of low-rank fuels for cement burning and other industrial applications requiring high temperature could well prove to be one of the most significant uses of the high-moisture coals in the less developed areas. Extraction of montan wax and the production of low-ash material suitable for carbon-electrode manufacture are among the possible minor industrial applications of selected low-rank

coals having the right chemical properties.

21. It is well-known that any rank of coal can serve as the basis for the production of a variety of organic chemicals. Coal supplies the necessary building blocks of carbon and hydrogen, and these can be formed into practically any synthetic organic compound. Carbonization, hydrogenation, gasification, and catalytic treatment are some of the major techniques used. The possibilities for such treatment are only mentioned within the context of this paper. Economic analyses have demonstrated that the production of chemicals by these techniques is competitive only when conducted on a very large scale. Such analyses have shown conclusively that there must be almost complete utilization of the fuel and of the byproducts in order to be economically attractive. Both of these considerations require that a well-developed industrial complex be established in order to use the quantity and variety of products that must be produced if such chemical processing is to be economical. By definition, the less developed areas do not yet have such complexes. I believe that it is premature to consider specific chemicals that can be made from the low-rank coals, but some of the major types of products that can be made from these fuels are solvents, protective coatings for pipe, rubber plasticizers, phenolic compounds for plastic manufacture, dye stuffs, fertilizers, and pharmaceuticals.

22. There are, however, two general areas of chemical utilization of the coal that might be considered; namely, synthetic liquid fuel and fertilizer production. Synthetic liquid fuels can be produced by complete hydrogenation of coal at high pressure and temperature and with suitable catalysts, or by the catalytic conversion of "synthesis gas", a mix-

ture of carbon monoxide and hydrogen, obtained from the controlled gasification of the coal. The general use of these techniques for producing liquid fuels is well-known, although specific application to any given coal would have to be studied through laboratory investigations. Each of these processing schemes results in relatively complete conversion of the coal. Low-rank coal may be carbonized in an entrained or fluidized carbonizer to produce tar for hydrogenation to liquid fuels. The difficulty, however, with this process is that about 65 percent of the potential heat in the coal remains in the char residue and uses must be found for this fuel. Large quantities of char will be produced and must be consumed if an economically sized plant is constructed. The major application for the char in large quantity would be for power generation, since char is an excellent fuel and can be efficiently utilized in properly designed power plants. It should be kept in mind that, if this latter application is considered, a large power-generating industry is required to maintain a balance in the utilization of the two major products.

23. Nitrogen-containing fertilizers are of extreme importance to the less developed areas of the world. Atmospheric nitrogen is fixed by combining it with hydrogen at elevated temperatures and pressures. Low-rank coals provide a source of the hydrogen through either carbonization or gasification. Carbonization requires that uses be found for the char and tar produced concurrently with the hydrogen and again an integrated, balanced, industrial complex is necessary. Gasification, on the other hand, results in reasonably complete conversion of the coal to hydrogen and carbon monoxide, and these two products

can be readily separated. The carbon monoxide can be utilized as a low-quality gaseous fuel even if no specific chemical application is available. Fluidized techniques are attractive for gasification, but conventional vertical shaft retorts using the briquetted fuel will probably prove more economical for carbonization. Fertilizer production must be conducted on a large scale to be economical, and large quantities of power are required. Such an industry should, therefore, be integrated with an adequate power generating installation.

24. Naturally oxidized lignites, such as leonardite, can be used as soil conditioners. They contain large percentages of naturally produced humates that are beneficial to the soil because of their ability to hold water and loosen the soil. Oxidized lignite generally occurs as outcrops or in beds under shallow, porous cover. The natural process of oxidation occurring over long periods of time can be approximated by chemical oxidation. Humates can then be extracted from the converted coal, or the entire mass of oxidized materials can be used as a soil conditioner. Oxidized coals, because of the water-holding power of the humates, are being used as additives to mud used in well drilling.

25. Any of the low-rank coals can be used for general industrial heating. They can be handfired or charged with a variety of mechanical stokers such as underfeed, traveling grate, or spreader. For such purposes it is not necessary to preprocess the coal, although care must be taken in selecting equipment designed to handle the type of ash found in the particular coal. For example, if the ash in a given coal has a high fusion temperature, the coal cannot be used in equipment requiring clinkering of the ash,

and accordingly, a low-fusion ash coal must be used in equipment providing for clinker removal. Most handfired units require lump material, but the fines can be briquetted as described before to make lumplike material suitable for handfiring.

26. Specialty carbons can be made from a wide variety of the low-rank coals, particularly those with low-ash contents. Some uses, such as electrodes for electrochemical applications, would not be of immediate interest in the less developed areas. The use of activated carbon produced from low-rank coals for water purification could be profitable. It is possible to convert lignite and other high-moisture coals to excellent activated carbons by carbonization in simple devices. For example, such carbons have been made in large quantity in externally heated rotary kilns, with no byproduct recovery.

27. Storage is a very important factor in the utilization of low-rank (high-moisture) coals. These coals become extremely reactive as they lose moisture. As the moisture evaporates from the capillaries in the coal, new internal surfaces are produced. In addition, the coal slacks or crumbles, also creating new surfaces. These new surfaces are extremely reactive, and any appreciable lot of low-rank coals merely heaped on the ground is susceptible to spontaneous combustion. This tendency towards firing has been a deterrent to the large-scale use of low-rank coals in many parts of the world. Storage is important because it is usually not possible to intergrade mining and transportation of coal with utilization in order to prevent the necessity for storage. For example, climatic conditions may make it necessary for mining to be practiced only during a portion of the year.

It may be too cold or too wet to operate the mines and to transport the coal during some seasons. If the coal cannot be properly stored, usually at point of use, it becomes necessary to restrict coal use to those industries operated on a seasonal basis. Seasonal operation would not be attractive to the power industry, where production is required throughout the year.

28. As mentioned earlier, the difficulty in storing low-rank coals arises from the drying of the coal and its subsequent oxidation and heating. This heat escapes slowly and the temperature rises, increasing both the rate of drying and the rate of oxidation. This spiral continues until the coal pile ignites. The proper technique of storage, therefore, is one which will prevent these effects. The best approach is to build the pile in layers. The coal is spread in a layer to reduce size segregation and is packed to a high-bulk density before the next layer is formed. By increasing the bulk density of the coal in the pile, circulation of air through the pile is minimized. This technique has proven more effective than either ventilating the piles or covering them with thin layers of sealing materials. The packing technique has proven effective on large storage piles, each containing as much as 1,000,000 tons of lignite. Another deterrent to the stocking of high-moisture coals is their tendency to freeze in the cars when they are shipped by rail in extremely cold weather. When this occurs, it is necessary to break up the coal or thaw it before the car can be unloaded. It has recently been demonstrated that freezing can be prevented by mixing a relatively small proportion of thermally dried coal with raw coal before loading.

29. The logical assignment of coals for specific uses requires at least some test-

ing or research. It is to this phase of coal utilization that I would like to direct a few remarks. I have observed that in some areas where there is little or no experience in coal utilization, the need for pretesting the coal to establish its properties and amenability to a specific use has not been recognized. It cannot be emphasized too strongly that even though we speak of coals in terms of large classes, each coal has certain individual characteristics that cannot be predicted. It is necessary in our present state of knowledge to treat such coals as individuals and to determine their specific capabilities. It is certainly possible for an experienced coal technician to block out the general areas of application from only a cursory examination, perhaps by only a visual examination, but selection of the specific equipment and optimum operating conditions requires testing and analysis of the coal.

30. If it is accepted that some competent examination of the coal should be made before utilization processes are finalized, the question arises as to how and where such studies should be made. Laboratory and research facilities should be established in each coal-producing country, but it is necessary that selected local personnel be trained in a country having an established coal industry and adequate research facilities. This training can then be utilized in the orderly establishment of the local research facilities. Parallel to this training of laboratory personnel, specific initial coal-utilization problems of the less developed area should be studied in existing laboratories in the more developed areas. By obtaining research data and design suggestions from established industrial countries, coal production and utilization can be initiated

---

in an efficient and reasonable manner. The existence of even a nucleus of a coal industry then provides the impetus for the development of the local laboratory and research facilities. It is very difficult to maintain continued interest and support in a laboratory being established in a country without the support of an operating industry in the same field.

31. A realistic approach to coal research must be maintained in development of the new facilities. The distinction must be recognized between fundamental and applied research, and the proper distribu-

tion of effort made in the research organization between these two lines. I believe that the most effective approach to the establishment of a coal research organization is to emphasize studies on applied technology. If the local laboratory can demonstrate the application of an existing technique or the development of a new technique that will result in production and utilization of a local coal, continuing financial and political support for this laboratory will be easier to obtain; the laboratory can then expand its fundamental studies.

# Auxiliary Injected Blast Furnace Fuels

J. H. STRASSBURGER

*Vice President, National Steel Corporation, Weirton, West Virginia*

## Introduction

1. A technological revolution has been taking place in blast-furnace practice during the past 10 years. This change in practice has been directed toward increased productivity, decreased coke rates, and minimized capital investment per annual ton of pig-iron capacity. Higher blast temperatures and improved blast-furnace burdens, together with the use of tuyere-injection techniques, have improved blast-furnace performance. Initially, steam was used in the blast to control the tuyere-zone temperature and to maintain a smooth working furnace. This practice made possible the use of higher blast temperatures with some reduction in coke rate and an increase in productivity. It was later found that when auxiliary fuels were injected into the tuyere zone of the blast furnace, the moisture could be reduced substantially and a marked decrease in coke rate could be obtained. Auxiliary injected fuels replaced from 10 to 25 percent of the metallurgical coke, and this reduced the requirement for metallurgical coal which is in short supply in many areas of the world.

2. At National Steel Corporation, the practice of tuyere injection was started in 1951 on the Weirton blast furnaces when controlled amounts of oxygen and mois-

ture were introduced into the blast furnace. This use of moisture with oxygen was necessary to maintain a normal tuyere-zone temperature and a smooth working furnace. Starting in the late 1950's, several experiments were conducted on the U.S. Bureau of Mines experimental blast furnace at Bruceton, Pennsylvania (1), and on the low-shaft blast furnace in Liege, Belgium (2), in which auxiliary fuels were injected into the furnace. The results of this work showed the potential of injecting fuels through the tuyeres in place of moisture to reduce coke rates and improve blast-furnace performance. Gas, oil, and coal (3) were used as auxiliary fuels in various phases of this work.

## Utilization of Auxiliary Fuels

3. The energy requirements of the blast furnace must not be neglected when injecting auxiliary fuels into the furnace. To provide for the energy deficit encountered with injected fuels, the practice of using higher blast temperatures and reduced moisture can be followed. Normally, the best practice is to operate at the maximum blast temperature available and the minimum moisture required to keep the furnace moving satisfactorily. As the quantity of auxiliary fuels injected into the furnace is increased, the

amount of moisture in the blast can be decreased. Gas, oil, or coal can be injected through the tuyeres, and experimental and operating data show that the greatest amount of blast heat is required for gas injection with oil requiring less blast heat and coal requiring the least amount of blast heat. This is illustrated in table 1 from a paper by J. M. Ridgion of BISRA (4). It will be noted in the

last column of table 1 that the amount of fuel which can be injected per 1,000 cubic feet of blast to compensate for an increase of 100° C in blast temperature varies widely. For example, with methane or natural gas, only 0.547 pounds of gas can be injected as compared with 1.107 pounds of fuel oil, and up to 2.062 pounds of coal to compensate for a blast temperature increase of 100° C.

TABLE 1. *Examples of properties of injectants*

Injected material	Heat release cal/g, H*	Equivalent		Composition		g/g Fe	Slag	lb/1000 ft <sup>3</sup> blast to compensate for +100° C
		C	H	O	N			
Fuel oil at 150° C. . . . .	-483	0.866	0.112	0	0	0	0.022	1.107
Coal—rank code 400. . . . .	-184	0.775	0.047	0.038	0.017	0.0161	0.15	2.062
Coal—rank code 600. . . . .	-344	0.728	0.047	0.067	0.016	0.0153	0.16	1.866
Coal—rank code 900. . . . .	-409	0.717	0.047	0.101	0.014	0.0114	0.15	1.812
Methane. . . . .	-1227	0.75	0.25	0	0	0	0	0.547
Coke-oven gas. . . . .	-817	0.4763	0.2175	0.1543	0.152	0	0	0.708
Steam in blast. . . . .	-3121	0	0.1111	0.8889	0	0	0	0.733
Magnetite concentrate. . . . .	-1004	0	0	0.2452	0	0.6417	0.1136	1.659
Limestone. . . . .	-1390	0.12	0	0.32	0	0	0.56	1.487

\*To facilitate subsequent computation H is evaluated using  $C + O_2 = CO_2 + 95800$  as for carbon in coke.

4. Table 2 is also from Ridgion's paper and it shows the effect of various injected fuels upon the fuel rate and production rate when accompanied with 100° C increases in blast temperature.

5. *Burden Requirements.* To obtain the best results with fuel injection, a benefited, sized burden should be used to maintain adequate stock-column permeability for good gas-solid contact. The replacement of coke in the burden with injected fuels naturally reduces the permeability of the burden, and, therefore, it is necessary that the ore burden be sized for the best gas flow up the stack. The reduction in coke requirements is illus-

trated by the fact that coke rates as low as 635 pounds per net ton of iron have been obtained experimentally. This has reduced the quantity of coke in the stock column and as a consequence has reduced the number of voids. It should be pointed out, also, that the use of fuel injection requires that the coke be of good quality with good stability in order to maintain its size while working its way down through the furnace stack.

6. *Injection Techniques.* Considerable experimental work has been performed to determine the best method of injecting fuels into a blast furnace. Auxiliary tuyeres, bosh tuyeres, and

TABLE 2. Effect of various fuels with 100° C increase in blast temperature  
(21% O<sub>2</sub>)

	Base	Fuel oil	Coal 601	Anthracite	Steam*	Methane**	Coke-oven gas***
Injected fuel (cwt/ton iron).....		0.57	0.97	1.37	0.41	0.30	0.40
Coke rate (cwt/ton iron).....	12.94	11.76	11.70	11.09	12.63	11.95	11.91
Coke saving (cwt/ton iron).....		1.17	1.24	1.85	.31	.98	1.03
Replacement ratio:							
(w/w).....		.49	.78	.74	1.33	.32	.39
(Btu/Btu).....		.75	.82	.84	.....	.64	.61
Top gas (%):							
CO <sub>2</sub> .....	15.5	16.0	15.6	15.8	16.0	15.9	16.0
CO.....	25.9	25.1	25.7	25.6	25.7	25.1	24.9
H <sub>2</sub> .....	1.0	2.0	1.7	1.7	1.6	2.1	2.3
CO/CO <sub>2</sub> .....	1.67	1.57	1.65	1.62	1.61	1.57	1.56
CV gross (Btu/ft <sup>3</sup> ).....	90.6	91.0	91.9	91.1	92.1	91.2	91.5
Potential increase in productivity (%).....		4.5	2.9	4.0	2.6	4.0	4.7

\*5.3 grain/ft<sup>3</sup>.

\*\*1.3% of blast.

\*\*\*2.6% of blast.

lances extending through the peep-sight cap have been used to inject auxiliary fuels. The experimental work which was performed at the U.S. Bureau of Mines (1) indicated that the best results were obtained when the injected fuel was introduced through the main tuyeres of the blast furnace. This, no doubt, developed rich bosh gases at a position in the tuyere zone where they could be distributed and utilized efficiently when moving up through the furnace. Various techniques have been used to inject fuels through the main tuyeres of the blast furnace. An injection lance has been placed through the peep-sight cap; injection blowpipes and injection tuyeres have been used. These practices will be described later under solid fuel injection.

7. Furnace Practice and Performance with Auxiliary Fuels. The following re-

sults have been observed and practices used with auxiliary fuels:

(a) When injecting auxiliary fuels into a blast furnace, the furnace works more smoothly due to improved control of the tuyere-zone temperature and improved gaseous reduction of the burden in the stock column.

(b) Normally, there is only a small increase in iron production when using auxiliary fuels provided the maximum blast temperature was utilized before auxiliary fuel usage was begun.

(c) It is a good practice to reduce the steam in the hot blast when injecting auxiliary fuels. This permits a greater savings in fuel.

(d) Little or no gangue materials are associated with many auxiliary fuels, and, consequently, this reduction in gangue material permits a re-

duction in slag volume with a corresponding saving in limestone and coke.

(e) About 6 or 7 hours (corresponding to the burden retention time in the blast furnace) before auxiliary fuel injection is begun, a reduction in the quantity of coke charged to the blast furnace is effected. This minimizes the disturbance in furnace performance when starting auxiliary fuel injection.

(f) When changing the burden ratio to compensate for auxiliary fuels, it is possible either to reduce the coke unit or to increase the burden unit. The size of the ore layer, and coke layer, the filling sequence, and the size of skip generally will dictate which unit is to be changed.

(g) It is possible to inject too much auxiliary fuel for the available blast heat, and this will result in an overall fuel rate that is higher than the minimum possible fuel rate. However, if the injected fuel is relatively low in cost as compared with metallurgical coke, the use of a larger amount of injected fuel may be economically justified for the replacement of expensive coke.

## Gas Injection

8. The Bureau of Mines, using its Bruceton experimental blast furnace, started work on fuel injection early in 1958. In 1959, cooperative work with the National Steel Corporation (1) was conducted to determine the benefits of natural-gas injection with high blast temperatures as compared with the use of steam with high blast temperatures. This work was conducted using blast temperatures equivalent to 1400–2000° F for a commercial furnace. Because of the small size of the Bruceton furnace, it

was necessary to carry 400–450° F excess blast temperature as compared with a commercial furnace to compensate for the larger heat losses of the small furnace. As a result of this experimental work, the information shown in figures I through IV was obtained:

9. Figure I shows the moisture in the blast plotted against blast temperature and indicates the increase in moisture that can be utilized with increasing blast temperature for good blast-furnace performance.

10. Figure II shows the percentage of natural gas injected in the blast (percentage of blast volume) plotted against blast temperature. This shows the possible increase in natural-gas injection with increasing blast temperatures.

11. Figure III illustrates the reduction in coke rate with natural-gas injection as compared to the use of steam in the blast. Curve AB is based on steam injection and shows that with an increase in blast temperature, the coke rate was reduced from about 1,420 pounds per net ton to about 1,320 pounds per net ton of iron. Curve AC with natural gas or methane injection shows that the coke rate was further reduced from the 1,420-pound base down to about 1,100 pounds per ton with the use of up to 5 percent natural gas at the 2000° F blast temperature.

12. Curve AD shows the practice of using natural gas with the stoichiometric amount of oxygen required to burn the injected natural gas to carbon monoxide and hydrogen. It is significant that in this practice the coke rate was still reduced to the 1,100-pound per-net-ton range despite a large increase in productivity as shown in figure IV.

13. Figure IV illustrates the change in the productivity of the blast furnace with

the use of methane injection as compared with steam. Curve AB with steam injection shows that the productivity increased from the equivalent of 1,520 tons of iron daily up to 1,870 tons of iron per day. Curve AC with up to 5 percent methane injection at the 2000° F blast temperature shows an increase in production up to 1,860 tons per day or about 1 percent less than with the steam injection. However, Curve AD with up to 5 percent methane, together with the stoichiometric amount of oxygen for burning it to carbon monoxide and hydrogen, shows an improvement in productivity with an iron production of about 2,100 tons per day as compared with the 1,860 tons per day without the oxygen enrichment but with the same amount of methane injection.

14. Based on the results of the auxiliary fuel investigations conducted at the Bureau of Mines, several plants in North America started to use natural gas, coke oven gas, or oil as auxiliary blast-furnace fuels (5).

15. At Great Lakes Steel Corporation, Division of National Steel Corporation, natural gas was placed on all four blast furnaces and the results to date have substantiated the experimental results obtained using the Bureau of Mines furnace. The anticipated coke savings on the commercial furnaces have been as good as or better than that obtained using the Bureau of Mines blast furnace.

16. *Description of the Gas-Injection System.* A gas-injection system is much simpler than an oil-injection system or a solid-fuel injection system. With the availability of high-pressure gas, a circle pipe is placed around the blast furnace, and individual lines lead from this circle pipe to the injection lance at each tuyere. Pressure controls and safety devices are

necessary to provide a dependable and safe system. The results at the Great Lakes Steel plant are shown in table 3 where injection rates of 2.5 percent to over 4 percent are compared with a base period without natural-gas injection. During these short test periods, approximately 90 pounds of coke were saved per 1,000 cubic feet of natural gas injected. Data obtained over longer periods of time have indicated a coke savings of about 75 pounds per 1,000 cubic feet of natural gas injected. This is based on the practice of not only maintaining high blast temperatures, but also decreasing the moisture in the hot blast while the natural gas is injected into the blast furnace. A relatively large number of blast furnaces in the United States are now using natural-gas injection, and they have obtained results similar to those presented here. The advantages of gas injection are as follows: (a) A gas-injection system is simple and inexpensive to install as compared with other fuels. (b) Gas is easy to move and meter. (c) Gas has little or no gangue and slag forming constituents. (d) Gas can be low in sulphur, which is an advantage to blast furnace practice.

17. The disadvantages of gas injection are: (a) The amount of gas that can be injected is limited by the blast temperature more than with other fuels such as oil or coal. (b) Gas can be expensive in certain areas and its supply can be irregular.

### **Oil Injection**

18. Considerable work has been conducted in various parts of the world on injecting fuel oil through the tuyeres of a blast furnace (6-7). This work has been successful in replacing blast furnace

TABLE 3. *Natural-gas injection—Great Lakes Steel Corporation*

Period	Base	I	II
No. of days . . . . .	31	11	15
Percent natural gas . . . . .	0	2.5	4.3
Production—tons/day . . . . .	1,915	2,043	2,063
Coke rate—lbs/ton . . . . .	1,322	1,170	1,075
Natural gas—cu ft/NTHM . . . . .		1,613	2,718
Coke saved—lbs/1,000 cu ft gas . . . . .		94.2	*90.9
Stone rate—lbs/ton . . . . .	501	460	421
Wind—CFM . . . . .	92,472	92,000	92,389
Blast temperature—° F . . . . .	1769	1751	1846
Moisture—grs/cu ft . . . . .	17.5	11.4	6.3
Blast pressure—PSI . . . . .	27	24.6	24.9
Percent Fe in burden . . . . .	54.01	54.01	54.01
Burden:			
Percent lime-sinter . . . . .	55	55	55
Percent Mesabi coarse ore . . . . .	26 $\frac{1}{8}$	26 $\frac{1}{8}$	26 $\frac{1}{8}$
Percent Menominee coarse ore . . . . .	18 $\frac{1}{8}$	18 $\frac{1}{8}$	18 $\frac{1}{8}$

\*Part of this coke saving can be attributed to higher blast heat.

coke with fuel oil. The oil to coke replacement ratio which has been obtained depends on the blast temperature available and the amount of oil injected. Various liquid fuels have been used including Bunker C, tar, light fuel oil, and miscellaneous oils.

19. *Oil Injection System.* An oil injection system is more complicated than a gas injection system. The following equipment and installation are normally associated with an oil injection system:

20. A storage tank for receiving and storing fuel oil is required. Pumps for pumping the oil to the blast furnace through a circle pipe are necessary as well as provisions for heating and maintaining the oil at a low viscosity for good flow. In general, oil is easy to meter and can be handled through either injection lances or through special injection blowpipes or tuyeres. With oil injection, it is usually necessary to purge at shut-

down periods to prevent carbonization in the lance. With the use of high blast temperatures in blast furnace operation, it has not been found necessary to atomize the oil to obtain fast and rapid combustion. The amount of oil required to replace a pound of coke will vary with the amount of oil being injected. At low injection rates, about 0.8 pound of oil will replace one pound of coke. At intermediate injection rates, about one pound of oil will replace one pound of coke, and at high injection rates, more than one pound of oil may be required to replace a pound of coke. Table 4 gives some results of oil injection work at the Dominion Foundries and Steel Company at Hamilton, Ontario.

21. The advantages of oil injection are: (a) The oil injection system is intermediate in simplicity and cost as compared with gas or coal. (b) Oil is rela-

tively easy to pump and meter. (c) It is possible to maintain a storage of fuel oil for protection of fuel supply.

22. The disadvantages of oil injection are: (a) The amount of sulphur present in some oils could cause some serious hot-metal desulphurization problems.

(b) The oil must be kept hot and moving. (c) The lance must be purged during shutdown periods to prevent carbonization in the lance. (d) Care must be exercised to prevent the formation of carbon black and avoid the problems associated with this material.

TABLE 4. Oil injection—Dominion Foundries and Steel, Ltd.

Period	Base	Low oil rate	Intermediate oil rate
No. of days	42	49	58
Iron production—NTPD	1,580	1,593	1,621
Corr. iron production—NTPD	1,635	1,615	1,649
Oil rate—lbs/NT		66	118
Coke rate—lbs/NT	1,235	1,155	1,123
Fuel rate—lbs/NT	1,235	1,221	1,241
Replacement ratio—lbs oil/lb coke		.82	1.05
Stone rate—lbs/NT	440	443	509
Slag volume—lbs/NT	598	609	649
Dust rate—lbs/NT	48	36	61
Wind rate—CFM	68,190	68,285	69,910
Blast temperature—°F	1592	1648	1645
Blast moisture—grs/cu ft	17.4	11.7	11.8
Blast pressure—PSI	23.0	24.1	24.4
Burden:			
Percent pellets	60.5	59.7	58.3
Percent raw ore	16.6	19.5	21.1
Percent coarse ore	18.8	17.4	18.5
Percent miscellaneous	4.1	3.4	2.1
Iron—percent silicon	1.15	1.16	1.12
percent sulfur	.025	.024	.024
Coke—percent ash	6.27	6.50	7.32
percent sulfur	.61	.60	.66
stability	56.6	56.6	56.7
Delays—minutes/day	47	20	24
Corr. prod.—NTPD/sq ft hearth area	4.20	4.15	4.25

### Solid-Fuel Injection

23. Of all the fuels available for injection into the blast furnace, coal requires the least increase in blast temperature, or for a given blast temperature, coal will replace more blast-furnace coke than either gas or oil. Coal is available in most parts of the world and is, there-

fore, a fuel which is in abundant supply. In many areas, coal is cheaper than either gas or oil and it has economic advantages as an injected blast-furnace fuel. Coal injection was tried on the Bureau of Mines blast furnace using anthracite as the injected coal. The results obtained when injecting coal indicated the pos-

sibility of replacing a large amount of coke with relatively small increases in blast temperature.

24. *Types of Fuel.* Many types of coals can be injected including bituminous, anthracite, and low-rank coals as well as char and other solid fuels. Coal injection has been used commercially on blast furnaces in the United States(8), France, and England. There are various types of systems available for injecting coal through the tuyeres of a blast furnace. The installation cost of coal-injection equipment is higher than the cost of equipment for injecting either gas or oil. However, when consideration is given to the relative low cost of coal as compared with other fuels in many areas, the additional capital investment for coal-injection equipment is justified in order to take advantage of this low-cost fuel.

25. *Coal Injection at Hanna Furnace Corporation.* The solid-fuel injection system at Hanna Furnace was installed in 1960 and the first coal was injected in December of that year. The system installed was a pseudofluid-bed type with temporary coal handling facilities for the unloading, crushing, and screening of the coal before it was transported by a vacuum system to storage tanks. The furnace on which this system was installed has a hearth diameter of 16 feet, 1 inch, and it has 8 tuyeres. Two parallel injection systems were installed with each system feeding alternate tuyeres. This arrangement was used so that if either system was inoperative, coal could be maintained on four tuyeres distributed uniformly around the periphery of the furnace. The coal is delivered from the injection tank through individual pipelines to each blast-furnace tuyere using compressed air as a carrier for the coal. Up to the present time, no circle pipe

has been used as in the case of gas and oil. The injection of coal through the tuyeres has been quite similar to the methods used with both gas and oil. Figures V and VI show four methods of coal injection.

26. The upper part of figure V shows the coal-injection lance extending through the peep-sight cap and up to within a few inches of the nose of the tuyere. This was the first method of injection. Later it was found possible to pull the lance back as far as 40 inches from the nose of the tuyere and still maintain good injection conditions without overheating the blowpipe. These tests were all based on a maximum of 1500° F blast temperature, but it is possible that with higher blast temperatures, the lance would have to be placed closer to the tuyere nose. The upper part of figure VI shows a special injection tuyere. However, this method resulted in erosion of the nose of the tuyere by the coal and it was abandoned. The lower part of figure VI shows the lance welded into the blowpipe with the end of the lance being about 30 inches from the nose of the tuyere. This was the best of all of the methods tried at Hanna Furnace. Using this method, it was possible to keep the peep sight clear for normal observation of tuyere conditions.

27. *Properties of Coal.* Four different coals were used during the solid-fuel injection test work. These were low-volatile Lower Kittanning seam coal, high-volatile Elkhorn seam coal, high-volatile Pittsburgh seam coal, and anthracite coal. Only a few cars of anthracite coal were used but more tests using this type of coal are contemplated for the future. Table 5 shows the proximate analysis of the bituminous coals and the coke used at Hanna Furnace.

TABLE 5. *Solid-fuel injection—Hanna Furnace Corporation*

Material	Coal and coke proximate analysis			
	Volatile matter	Fixed carbon	Ash	Sulfur
	<i>Percent</i>	<i>Percent</i>	<i>Percent</i>	<i>Percent</i>
Lower Kittanning.....	17.57	74.88	7.55	0.94
Elkhorn.....	37.68	58.69	3.63	.78
Pittsburgh.....	40.00	55.58	4.42	1.14
Coke.....	1.10	90.91	7.99	.74

28. *Moisture in Coal.* With the pseudo fluid-bed system used, it was found necessary to maintain the moisture in the coal under 3 percent to obtain satisfactory movement of the coal through the solid-fuel injection system. Since there were no coal-drying facilities in the coal-preparation plant, it was necessary to procure coal that had no more than 3 percent moisture in it. This coal was shipped in covered railroad hopper cars to prevent any moisture increase in the coal during transit.

29. Most of the coal that was delivered to the coal-preparation plant was minus 1 inch in size. In the initial test work, the size of the coal going to the solid-fuel injection unit after passing through the vibrating screen was minus  $\frac{1}{8}$  inch. Later in the test program, minus  $\frac{3}{16}$ -inch coal was used and this size consist was used satisfactorily in the blast furnace. Excessively large amounts of minus-100 mesh coal could result in plugging of pipe lines.

30. Some degradation of the coal occurred in transit from the coal-preparation plant to the blast furnace. The coal at the blast furnace contained from 2 to 10 percent more minus-100 mesh material than did the coal leaving the preparation plant. The softer, more friable coal had

a tendency to break up more than did the harder coal.

31. *Operating Results.* Table 6 shows the operating data obtained during the solid fuel injection experiment at Hanna Furnace Corporation. From the work that was conducted at the Hanna Furnace plant with the modest amount of blast temperature available, it is opined that a pound of coal injected through the tuyeres can replace a pound of metallurgical coke in the blast furnace.

32. *Other Coal Injection Systems.* There are several other coal-injection systems available for use on the blast furnace. Based on the results of the work at Hanna Furnace, National Steel is now installing a coal-injection system on a 20-tuyere blast furnace of 27-foot hearth diameter at Weirton, West Virginia. This system will be based on using the coal feeder developed by the Bituminous Coal Research, Inc. The coal feeder was selected because it could transport moist coals, it could meter the coal, and its use would make possible a comparison between the coal-feeder system and the pseudo fluid-bed system.

33. *Advantages of Coal Injection.* The advantages of coal injection as compared with either gas or fuel oil are as follows: (a) Coal injection makes possible the

TABLE 6. Solid-fuel injection—Hanna Furnace Corporation

1. Test period	Base	Lower Kittanning	Base	Pittsburgh
2. Percent coal injected	0	17.8	0	16.5
3. Type of iron produced	Malleable	Malleable	Malleable	Malleable
4. Number of days	12	12	12	11
5. Production rate—NTPD	675	665	667	669
6. Corrected production—NTPD	676	675	676	676
7. Coke rate—lbs/ton*	1,566	1,315	1,590	1,340
8. Coal rate—lbs/ton	0	284	0	264
9. Fuel rate—lbs/ton	1,566	1,599	1,590	1,604
10. Replacement ratio—coal/coke	.....	1.13	.....	1.06
11. Stone rate—lbs/ton	862	750	754	704
12. Slag volume (calc)—lbs/ton	946	873	950	946
13. Blast temperature—°F	1,455	1,478	1,465	1,500
14. Moisture—grs/cu ft	11.8	9.9	10.8	8.3
15. Wind rate—ordered—CFM	39,000	39,000	39,000	39,000
16. Dry-dust rate—lbs/ton	24.6	28.9	13.0	22.7
17. Blast pressure—PSI	17.7	17.6	17.9	17.8
18. Burden ratio—ore/coke	2.30	2.71	2.18	2.56
19. Burden ratio—ore/fuel	2.30	2.25	2.18	2.18
20. Charges/day	128	128	135	133
21. Burden—%:				
22. Coarse ore	81.3	72.7	68.5	65.0
23. Sinter	0	0	21.5	25.0
24. Run-of-mine ore	15.6	26.0	10.0	10.0
25. Pellets	3.1	1.3	0	0
26. Percent Fe in burden	52.68	52.71	53.14	53.04
27. Top temperature—°F	254	378	206	282
28. Top-gas analysis—%:				
29. CO	25.7	25.4	25.7	25.3
30. CO <sub>2</sub>	16.3	15.7	15.9	14.9
31. H <sub>2</sub>	2.9	3.6	2.6	3.6
32. N <sub>2</sub>	55.2	55.3	55.8	56.2
33. CO/CO <sub>2</sub> Ratio	1.58	1.62	1.62	1.70
34. Btu/cu ft (calc)	92.2	93.7	91.0	92.3
35. Metal analysis—%:				
36. Si	2.34	2.32	2.37	2.27
37. S	0.025	0.027	0.023	0.025
38. Mn	0.93	1.01	0.92	0.93
39. P	0.100	0.289	0.093	0.093
40. Slag basicity	0.96	0.99	1.06	1.01
41. Slag analysis—%:				
42. SiO <sub>2</sub>	39.13	38.13	37.34	38.42
43. Al <sub>2</sub> O <sub>3</sub>	10.89	11.13	10.40	10.45
44. CaO	40.63	41.13	40.28	39.71
45. MgO	7.43	7.78	10.32	9.57
46. S	1.47	1.64	1.47	1.68
47. Fe	0.34	0.34	0.34	0.34
48. Mn	0.53	0.40	0.34	0.47
49. Delays—min/day	1.25	20.1	19.2	15.0

\*Corrected to 2.5% moisture.

utilization of low-cost coals of which there are large reserves in many parts of the world. (b) The injection of noncoking coals through the tuyeres of a blast furnace will utilize coals that are unsuitable for the production of metallurgical coke. (c) Coal requires less blast temperature than either natural gas or fuel oil and is, therefore, capable of replacing more metallurgical coke than the other fossil fuels.

34. *Disadvantages of Coal Injection.* The disadvantages of coal injection are: (a) A more complicated system with a higher capital cost. (b) Coal is more difficult to move and meter than is a liquid or a gaseous fuel.

#### **Other Auxiliary Fuels**

35. Some work is now being performed involving the use of a coal-oil slurry and work will possibly be conducted later with a coal-water slurry. In the case of the coal-oil slurry, the use of this type of fuel could possibly simplify the system for injecting coal into a blast furnace, but the economics of using oil with coal would have to be evaluated closely. If the oil is more expensive per million BTU than the coal, a higher priced composite fuel is being injected into the furnace which could result in higher costs and reduced savings. The coal-water slurry has the advantage of a simpler pumping and piping system for the handling of coal, but it has a distinct disadvantage in that some blast heat will

be required to evaporate the moisture. The amount of coal injected would be limited by the amount of moisture that the blast furnace could tolerate in the tuyere zone.

#### **Conclusion**

36. In summarizing the results of the work up to date with auxiliary fuel injection, it is significant that this practice has resulted in a lower blast-furnace fuel cost and a lower hot-metal cost. It will make possible lower capital costs for the blast furnace because fewer coke ovens will be needed for the production of metallurgical coke. Fuel injection will also make possible increased blast-furnace productivity by making the best possible use of higher blast temperatures. The determination of whether to use a gaseous, liquid, or solid fuel will depend on the economic advantages of each fuel in the particular geographical area being considered. No blanket statement can be made that one fuel is better than another. Gaseous and liquid fuels are easier to handle and inject into the furnace, but in areas where solid fuels are considerably lower in cost the complication and added expense of utilizing the solid fuels can be economically justified. The use of fuel-injection techniques will reduce the requirement for coke and, therefore, extend the reserves of metallurgical coal which are in limited supply in many parts of the world.

## REFERENCES

- (1) Ostrowski, E. J., G. H. Kesler, N. B. Melcher, *Investigation on the Enrichment of Blast Furnace Air*, Blast Fur., Coke Oven and Raw Mat. Proc., AIME 19, 279-292 (1960).
- (2) Bonnaure, E. P., *Results of Campaigns Performed in 1958 at the Low-Shaft Blast Furnace of Liege*, Blast Fur., Coke Oven and Raw Mat. Proc., AIME 18, 75-91 (1959).
- (3) Ostrowski, E. J., M. B. Royer, L. J. Ropelewski, *Injecting Solid Fuels Into Smelting Zone of an Experimental Blast Furnace*, U.S. Bur. of Mines Rept. of Investigation 5648, 14 pp. (1960).
- (4) Ridgion, J. M., *Blast-furnace performance with injection at the tuyeres*, Journal of The Iron and Steel Institute, 135-143 (Oct. 1961).
- (5) *Carbonaceous Fuel Additives to the Blast-Furnace Hot Blast*, Blast Fur., Coke Oven and Raw Mat. Proc., AIME 20, 540-604 (1961).
- (6) Noel, E., J. Molderez, A. Poos, *Fuel-Oil Injection Tests on the Blast Furnace 4 at the Cockerill-Ougrée Works in Liege-Belgium*, Centre National De Recherches Metallurgiques, Liege, Belgium (1961).
- (7) Knepper, W. A., P. L. Woolf, H. R. Sanders, *Operation of the Bureau of Mines Experimental Blast Furnace With Fuel-Oil Injection*, Regional Technical Meeting, AISI, 83-100 (1961).
- (8) Strassburger, J. H., E. J. Ostrowski, J. R. Dietz, *Solid-Fuel Injection at the Hanna Furnace Corporation*, Blast Fur., Coke Oven and Raw Mat. Proc., AIME (1962).

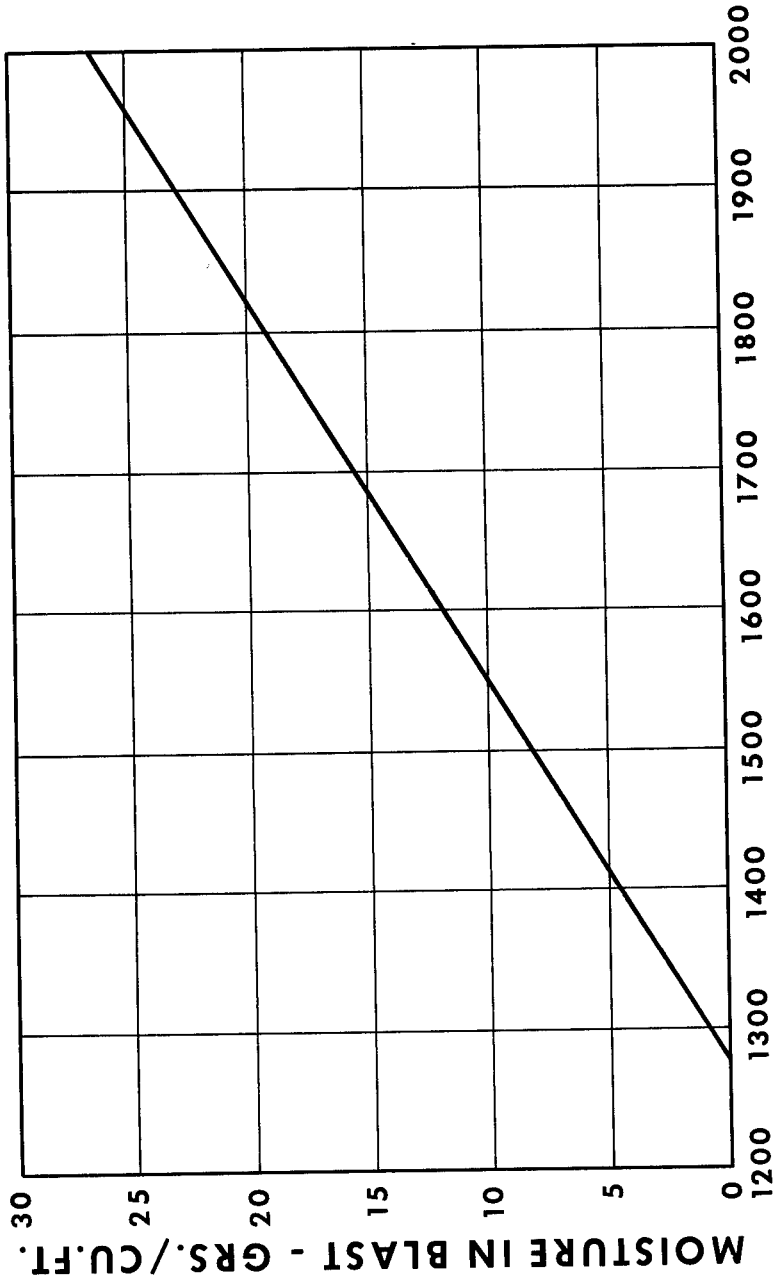

**BLAST TEMPERATURE - °F**

FIGURE I. Increased moisture utilization with increasing blast temperature.

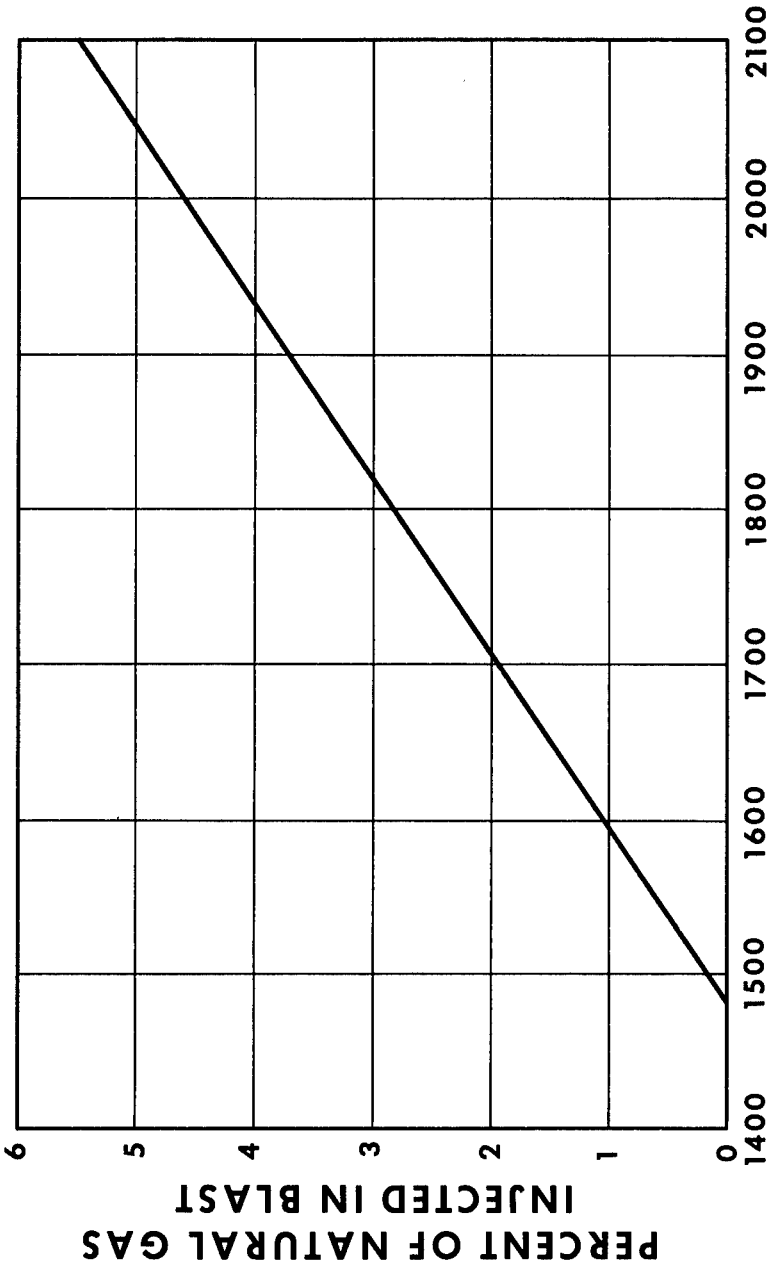

**BLAST TEMPERATURE - °F**

FIGURE II. Increased natural-gas injection with increasing blast temperature.

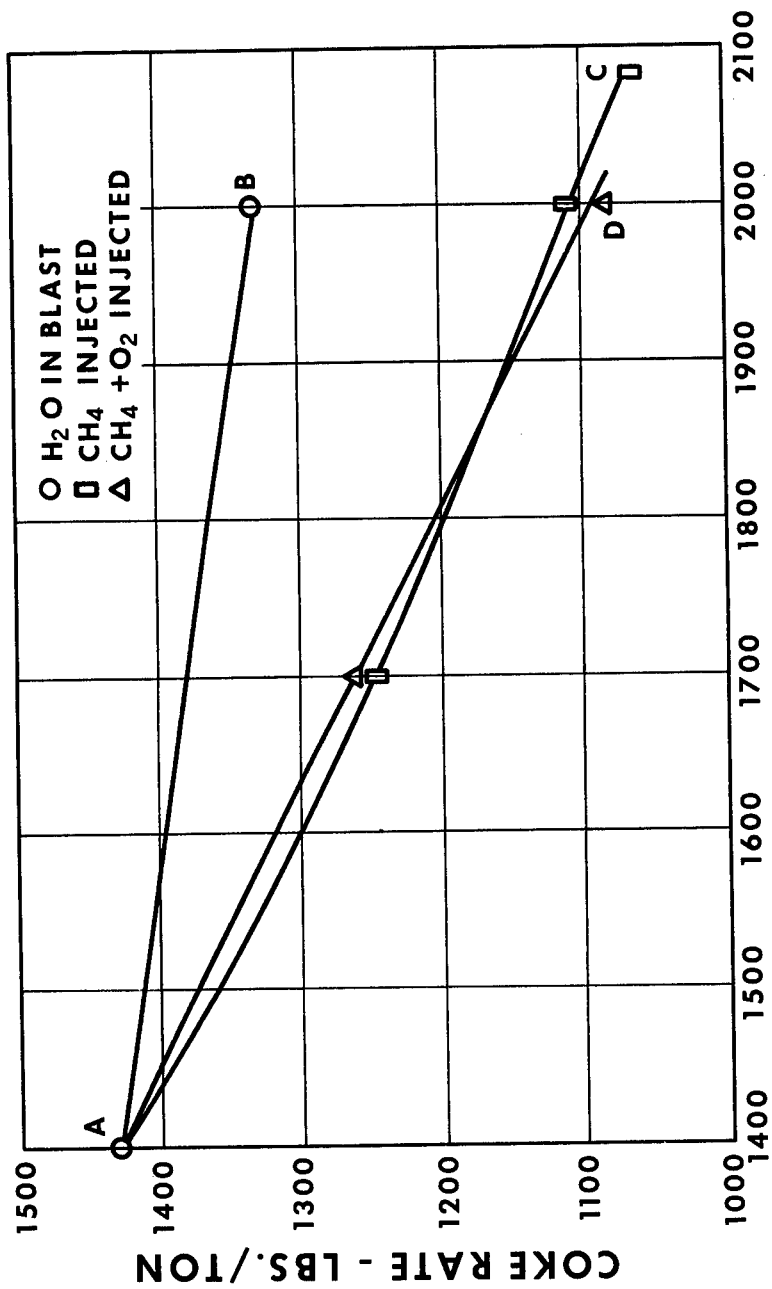

### BLAST TEMPERATURE - °F

FIGURE III. Reduction in coke rate with natural-gas injection as compared to use of steam in the blast.

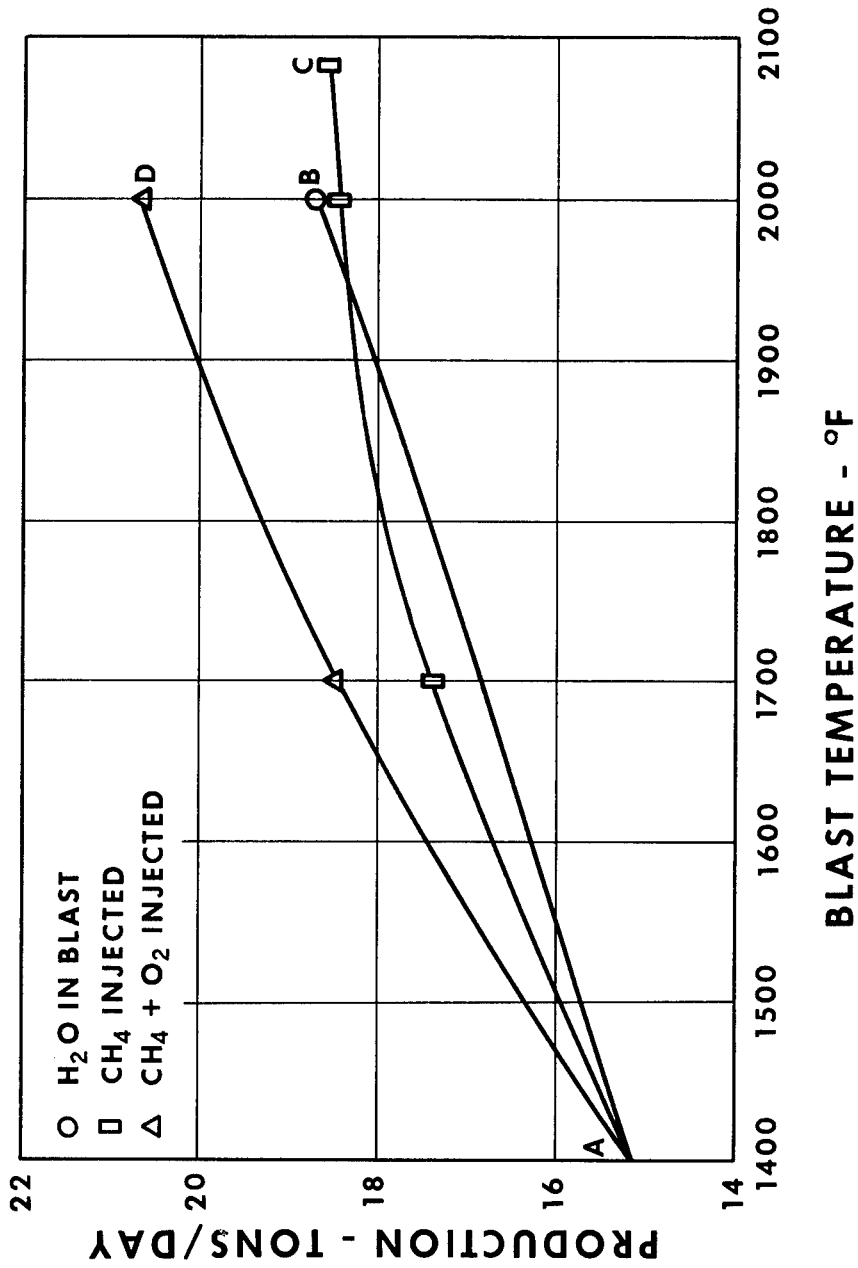

FIGURE IV. Change in productivity with methane injection as compared with steam.

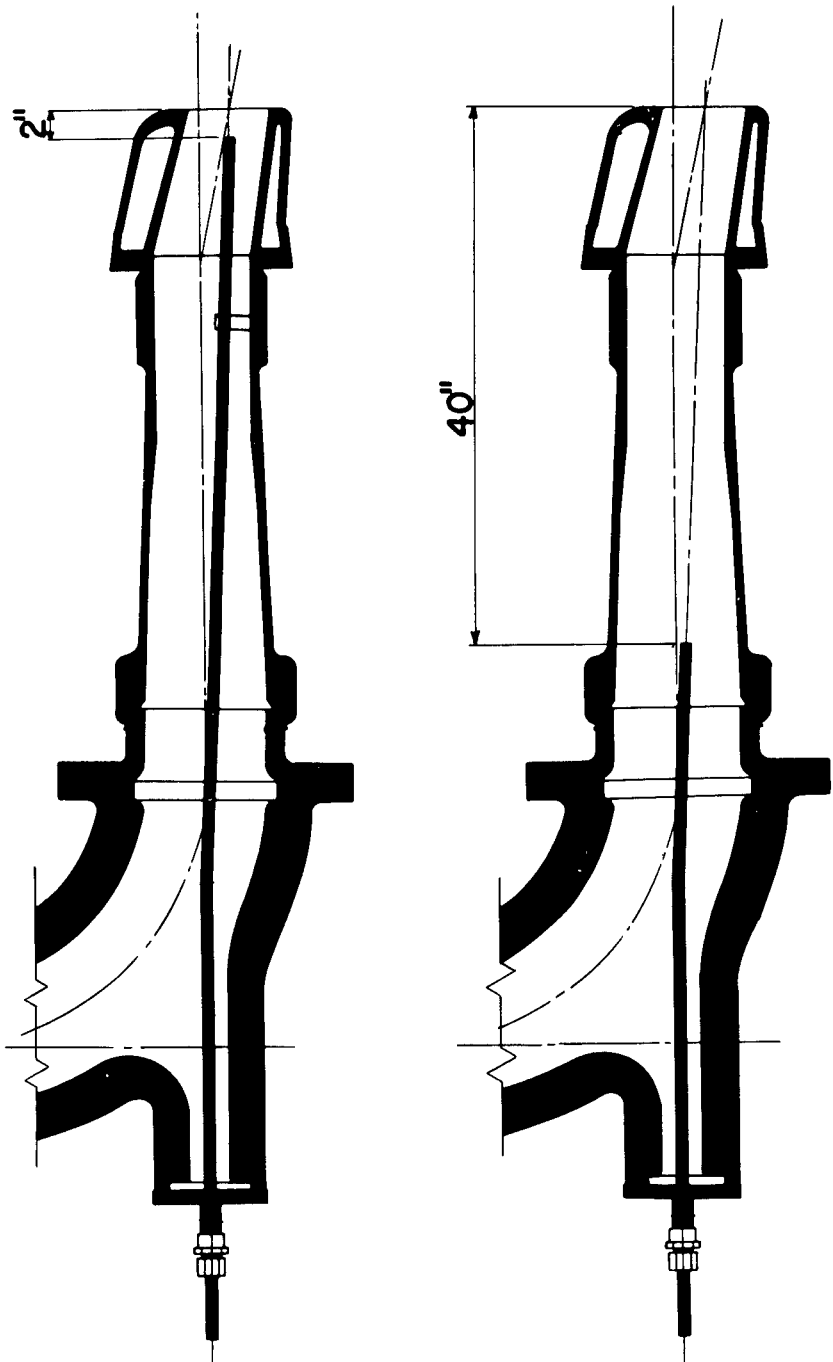

FIGURE V. Positions of injection lance.

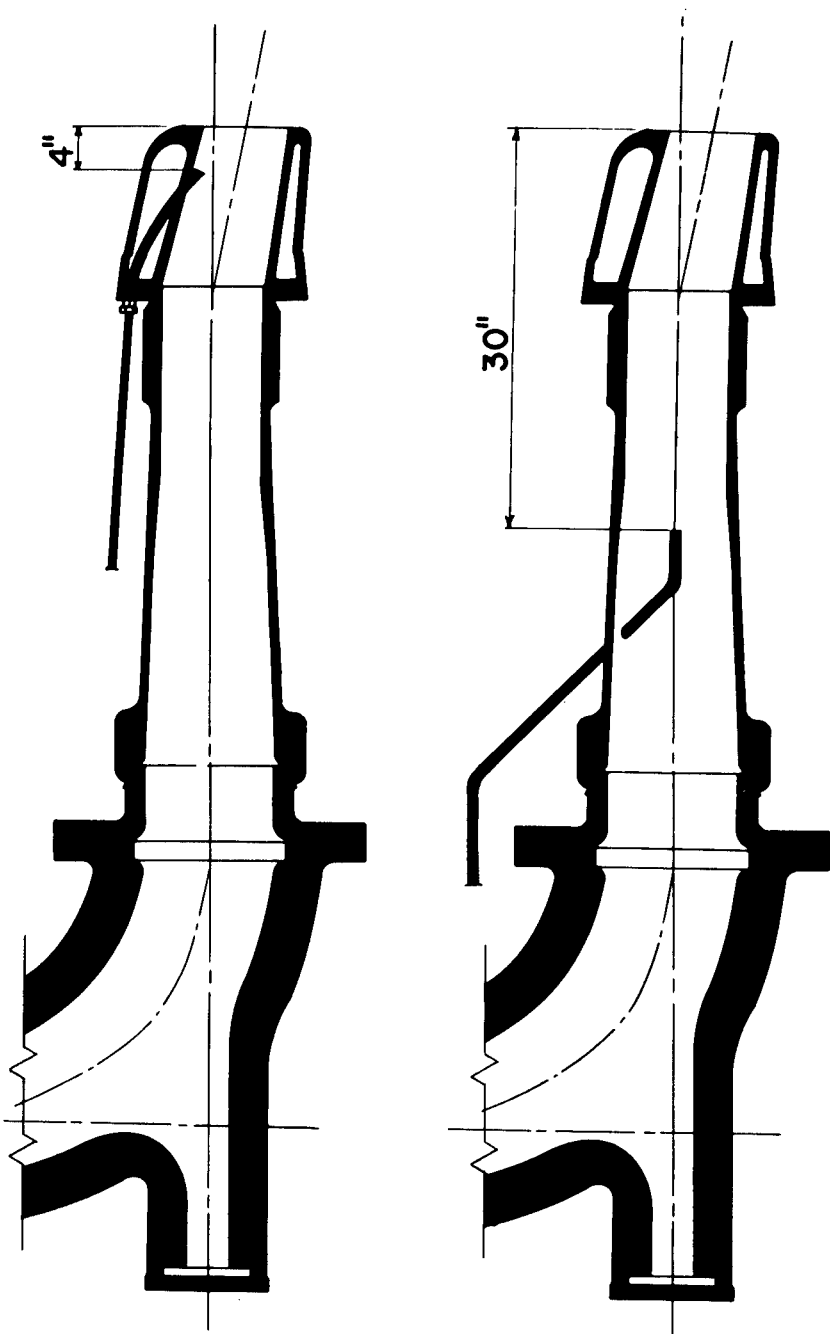

FIGURE VI. Injection tuyere and injection blowpipe.

## *Oil: Achieving Productive Capability*

### Financing Oil Expansion in the Development Decade

EDWARD SYMONDS

*Petroleum Economist, First National City Bank, New York City*

1. The 1960's have been designated the Development Decade, during which the United Nations General Assembly has called for a rate of economic progress to put the developing countries, 10 years hence, "on or over the threshold of self-sustaining growth." The effort to raise the living standards of these countries, and to foster their widening application of modern productive techniques, is one of the great challenges of today. But it is a challenge that cannot be met without sharply increased use of energy. Present energy use per head in the developing regions<sup>1</sup> is only 1/20 of that in the main industrial regions.

2. The probable importance of oil in the development process is suggested by table 1, showing the forward strides of

this energy form over the last three decades—from 30 percent of total commercial energy in 1929 to 54 percent in 1961. In Latin America, where the growth of energy use has been the most striking, oil now accounts for 72 percent of the total. Despite this advance, per-head petroleum consumption in the developing regions remains at only four-fifths of a barrel a year—1/25 of that in the United States and 1/5 of that in Western Europe. The unique value of oil in developing regions has already been amply demonstrated, and an increase in their present low rate of consumption will be an essential condition of progress.

3. With the present surplus of oil, as of almost all commodities, there is no question as to the existence of reserves

TABLE I. *Growth of energy demand in developing regions, 1929, 1951, and 1961*

[Thousands of Barrels Daily of Crude-Oil Equivalent]

	1929			1951			1961		
	Total energy	Of which: Oil		Total energy	Of which: Oil		Total energy	Of which: Oil	
		Vol.	%		Vol.	%		Vol.	%
Asia*	498	91	18.3	899	336	37.4	1,820	787	43.2
Africa	224	31	13.8	584	171	29.3	925	330	35.7
Latin America	354	198	55.9	1,025	672	65.6	2,079	1,496	72.0
Total	1,076	320	29.7	2,508	1,179	47.0	4,824	2,613	54.2

\*Noncommunist developing countries.

Source: 1929 and 1951—Based on United Nations, *World Energy Supplies*; 1961—Estimated by Petroleum Department, First National City Bank, N.Y.

adequate to meet the petroleum needs of the developing regions, both in this decade and for an appreciably longer period. But a real question exists as to the ability to attract the necessary support in financial resources. The purpose of this paper is to indicate the shape of the financial need arising out of the expected growth of demand in the developing regions, and to outline possible ways of meeting it in the Development Decade.

### Problems of Producing Countries

4. Even in established oil-producing countries, financing problems are beginning to emerge. These countries are in the rare position of enjoying income whose continuance requires no further expenditures on their part. But increasing perplexities face them in ensuring the best use of their oil revenues.

5. Oil income is derived from the depletion of a natural asset that will ultimately be exhausted. As such, it possesses some of the qualities of capital and should

be used to create new capital. This is one of the objectives of the development plans drawn up in nearly all oil-producing countries. But, while the oil revenues of the Middle East, for example, (see table 2) are now approaching \$1½ billion, planned development expenditures in that region have already reached a large proportion of these revenues and are rising from year to year. The need for rigorous control over other forms of expenditure and for care in preparing development programs is likely to increase as the decade proceeds.

6. This being the case, proposals to launch new government ventures in the oil business should be carefully weighed. In view of the present world surplus of crude oil, it may be questioned whether this is a good time to do so. Even more important, the chances are that the overall economic interests of a country with a highly developed oil industry would be better served by fostering investment in other fields, thus encouraging the economic diversification so vital

TABLE 2. *Oil production and revenues in selected developing countries, 1957, 1959, 1961*

	Production (000B/D)	Estimated payments to governments (\$000,000)
<i>Middle eastern producing countries</i>		
Kuwait:		
1957.....	1,140	305
1959.....	1,383	409
1961.....	1,644	454
Saudi Arabia:		
1957.....	992	295
1959.....	1,095	294
1961.....	1,393	365
Iran:		
1957.....	721	213
1959.....	945	262
1961.....	1,183	290
Iraq:		
1957.....	448	144
1959.....	853	243
1961.....	1,001	265
Qatar:		
1957.....	139	45
1959.....	168	53
1961.....	176	55
Neutral Zone:		
1957.....	64	10
1959.....	116	19
1961.....	176	28
Bahrain:		
1957.....	32	10
1959.....	45	13
1961.....	45	13
<hr/>		
Total Middle Eastern producing countries:		
1957.....	3,536	1,022
1959.....	4,605	1,293
1961.....	5,618	1,470
Total Middle Eastern transit countries: *		
1957.....	44	59
1959.....	58	119
1961.....	71	142
<hr/>		
<i>Other producing countries</i>		
Venezuela:		
1957.....	2,779	1,144
1959.....	2,771	966
1961.....	2,920	978

See footnote at end of table.

TABLE 2. Oil production and revenues in selected developing countries, 1957, 1959, 1961—Continued

	Production (000B/D)	Estimated payments to governments (\$000,000)
<i>Other producing countries—Continued</i>		
Indonesia:		
1957.....	313	66
1959.....	381	97
1961.....	430	110

\*Egypt, Syria, Lebanon, and Jordan.

Source: Production—U.S. Bureau of Mines, *World Petroleum Statistics*.

Payments—Middle Eastern Countries—United Nations, *Economic Developments in the Middle East, 1959-1961* supplemented by estimates of the Petroleum Department, First National City Bank, N.Y. Venezuela—Ministry of Mines and Hydrocarbons, *Algunos Aspectos de las Actividades Petroleras Venezolanas y Mundiales—1961*. Indonesia—Estimated by the Petroleum Department, First National City Bank, N.Y.

to future stability. Private oil companies have themselves shown awareness of this need for diversification of the national economies of which they are a part, and have given support to various productive projects unrelated to oil.

7. Some producing countries, unlike other developing countries, may find themselves in a position to become investors abroad. But foreign oil ventures are unlikely to be the most promising direction for this outward flow of capital. A new and imaginative approach was recently adopted by a major producing country when it set up a loan fund to support general development projects in neighboring countries.

8. Meanwhile, changes have been occurring in the funds available from the traditional, private sources in the industrialized countries, and fresh problems are arising in attracting these funds. Although annual net earnings of U.S. oil companies as a whole have risen by almost \$1 billion over the last 10 years,

bringing them to \$3.2 billion in 1961, as a percentage of net assets they have fallen, over the same period, from 16.7 percent to 10.4 percent. (Similar trends are visible in the record of European oil companies.) A continued decline in the rate of return earned by oil companies would react directly on their ability to sustain their investment effort. Their internal resources can be supplemented by funds drawn from the capital markets. But market conditions have not favored equity issues by oil companies for the past several years. If the rate of return were to decline further, it would become even more difficult to attract outside investors.

### Changing Patterns of Partnership

9. In discussing their foreign investment for the years ahead, oil companies have drawn attention to various kinds of inroads that are now being made into their earnings in particular countries.

Partly for this reason, they are becoming more interested in raising local funds and are showing more flexibility as between loan and equity capital. They have long been aware of the advantages of raising loan capital in the countries of operation and thereby associating the local investment community with the success of the venture. Loan capital also has the advantage that it can be raised somewhat more readily than equity capital in countries whose financial mechanisms are still in the early stages of growth. But new possibilities are now being opened to the companies by the increasing eagerness of developing countries to take an equity interest in oil ventures within their borders.

10. Formerly, immaturity of capital markets in many developing countries made it particularly difficult for them to take up whatever equity participation had been planned. In the case of a joint venture with the Burmese Government in 1954, more than 6 years were required before the Government accumulated the funds represented by its 51 percent share. No local private capital was available, and the Government's original share had in the first place to be partly raised through a loan from the oil company concerned. The feasibility of joint ventures with local interests is now considerably greater. This year, for instance, Libya's National Oil Company, set up with minority holdings by a group of smaller foreign companies and cooperatives, successfully sold 51 percent of its stock to the public in a period of less than 2 months.

11. A trend toward substantial local participation is also beginning to emerge in refining. In India, two of the international companies have recently offered to change the basis of operation of their

existing refineries by setting up rupee refining and marketing organizations open to local equity participation by private investors. An agreement to construct a refinery in Vietnam provides for 50 percent participation to be subscribed over a number of years by the Government and local investors. A refinery in Nigeria will be owned 50 percent by the Government until it comes on stream in 1964, when local investors will also be invited to participate; the interest of the international companies concerned may then be reduced to 40 percent. A refinery now under construction in the Philippines will be 25 percent owned by one of the international oil companies, most of the remaining interest being held by local, private investors. In a number of cases companies new to the international oil business have accepted a minority position with local partners, seeking to make up for their competitive disadvantages on other scores by considering equity positions that in earlier years would have been treated as unacceptable.

12. It remains to be seen whether substantial financial benefits will in practice be reaped by developing countries from their preference for these joint ventures. But, in any event, it seems that these ventures are setting a novel pattern in international finance. Until now, the practice in most manufacturing and many extractive ventures abroad has been for the investor to insist on control, preferably through 100 percent ownership. It is, therefore, noteworthy that, in many of these ventures, full ownership of the refinery or other asset will pass to the host country after a specified number of years. According to the hitherto accepted norms of direct investment abroad, the foreign asset remained indefinitely in the hands of the investor.

### Outside Investors Enter

13. From trends such as these it seems clear that the shape of oil-industry financing in developing countries in the present decade may differ significantly from what was accepted as normal in the past. One spur to further innovation will be the fact that all developing countries are anxious to obtain the benefit of oil operations and some of them have expressed impatience at what they consider an inadequate investment effort by the oil companies. Among the various routes that they have followed in seeking new sources of external capital have been efforts to attract private investors from outside the oil industry. In the well-known Neutral Zone case, a group of Japanese public utilities, steel, shipping and insurance companies and other large concerns joined together to launch an offshore exploration venture. In Libya and Argentina, chemical, pipeline, and finance companies from abroad agreed to participate in the oil search, while companies outside the industry have also shown an interest in building refineries in developing countries. These ventures depend, of course, on the desire of such companies to diversify their activities, and on their ability to mobilize from oil-industry sources the necessary technical knowledge.

14. Commercial bank funds, though flowing in for other purposes, have not often been attracted into oil ventures in the developing regions. Hence it is significant that in certain countries and in certain situations these funds are now being increasingly tapped without the security of oil-company guarantees. In 1961, the U.S. commercial banking system committed some \$700 million in domestic lending on the strength of oil

and gas still in the ground. The total of outstanding loans made on this security by American banks has now probably risen to over \$3 billion.

15. Bank loans abroad normally have to rely on the backing of company or government guarantees. Interest rates are not pitched at a level that compensates for the additional foreign-exchange risks, the political uncertainties, the legal difficulties and the many other bars to lending without these guarantees. But the continued progress of the oil industry in developing countries suggests that further channels of private finance will open during the decade.

### Foreign Government Funds

16. With today's widespread participation by governments in economic affairs, public funds from the industrialized countries constitute a possible new source of oil financing. Much of the effort of these countries has so far been a part of their drive to encourage exports. In Britain, the Government takes an active part in spurring sales of petroleum equipment through the Export Credits Guarantee Department. Germany also provides official financing to cover specific export orders. In Italy, increasing support for foreign oil and gas ventures is now being supplied through the Government-owned Ente Nazionale Idrocarburi, which has also begun to embark on foreign oil ventures on its own account.

17. France has undertaken a different and more ambitious program, under which it aimed to bring investment in oil ventures to a total, between the end of 1945 and the end of 1962, equivalent to \$2.4 billion. In the first post-war years, as much as 80 percent of this in-

vestment, some three-quarters of which has been outside metropolitan France, was financed from public funds. But the large Saharan oil and gas discoveries have attracted capital from third countries and at the same time caused a sharp increase in the generation of local funds available for reinvestment. This has made possible a steady reduction in dependence on new funds from the Government, which in 1962 served to finance less than 10 percent of this investment effort.

18. In the United States, official financing and guarantees have traditionally been available to stimulate exports to private purchasers but not to government agencies. This policy was modified in March 1961, when the Administration decided that the Export-Import Bank should henceforth also be prepared to assist exports to government oil agencies. Since that time, the Bank has made loans totaling approximately \$10 million for petroleum and related purposes—but primarily in the private sector. Some large government projects, such as a proposed oil-shale venture in Brazil, have also been studied. But the role of government loans in the American contribution to the world oil business is unlikely to be more than marginal. Exploration programs, usually the riskiest and costliest part of an oil enterprise, remain outside the scope of Export-Import Bank activities. The main drive will presumably continue to come from American private companies, whose total investment in oil ventures abroad has recently been running at some \$3 billion a year.

19. The Russian Government has been increasingly active in offering finance for foreign oil enterprises. Some of this activity has taken the form of low-interest loans for oil exploration—in India,

Pakistan, and other countries. Elsewhere the Russians have shown an interest in refinery building in countries previously depending on imported products. In such cases, the Government would have to choose between obtaining a refinery constructed with the help of Russian loan capital or one financed by equity capital provided by the international companies.

20. The increased availability of loans from foreign governments brings the danger that developing countries will build up an unmanageable load of foreign debt. They can help to avoid this—though possibly at some political cost—by taking advantage of grant programs, such as that under which the United States recently offered \$4 million to Yacimientos Petroliferos Fiscales in Bolivia. The local-currency repayment arrangements offered to many countries by Russia, and to recipients of agricultural products by the United States, have a similar effect.

### International Agencies

21. Intergovernmental agencies that have come into existence since the end of World War II have added fresh channels through which capital can flow into developing countries. In general, however, the other needs of these countries have proved so great that only in rare cases have the new agencies considered oil and gas an appropriate field for their financing.

22. The World Bank is directed in its Charter only to use its own funds “when private capital is not available on reasonable terms.” It has made loans for a gas pipeline in West Pakistan and a crude-oil pipeline in Algeria. But the bulk of its resources—large enough to support an annual disbursement rate of \$400-600 million—is used for power,

transport, irrigation, and other essential activities in which the government often has to take the lead. Similar policies are followed by the newly created International Development Association, which has already made loans totaling more than \$230 million on very favorable terms—up to 50 years' maturity with a long grace period and no interest. The International Finance Corporation, another World Bank affiliate, makes investments in industrial enterprises in developing countries but only when they are privately owned.

23. The United Nations Special Fund has approved plans to launch a Petroleum Institute in Argentina and another in India, thus sharing with those countries the cost of starting a research and training program for the industry. But grants from the Fund are available for preinvestment surveys, not for project financing, so that it cannot collaborate except at the earliest stages of a petroleum venture. The Inter-American Development Bank, another of the recently created agencies, concentrates its effort on major public projects in Latin America that would otherwise be unable to raise the necessary capital. The improbability that these various inter-governmental agencies will be prepared to support an oil and gas venture is underlined by the fact that by early 1962 only \$67 million—less than 1 percent of their combined outlays to date—had been for projects in this field.

### The Balance To Be Struck

24. The eagerness of governments of developing countries to ensure the maximum inflow of capital, whether private or government, for petroleum purposes springs partly from the unquestionable

importance of oil in the development process. But a strong urge also arises from the high capital costs of the industry and the many other calls upon the resources of governments committed to speeding the growth of countries that have hitherto lagged behind in the economic race.

25. Making no allowance for investment to increase net exports to the industrialized regions, the capital needed to meet the growth of oil and gas demand in the developing regions in this decade is likely to total at least \$15 billion. This total would be required to satisfy an annual growth rate of 6.5 percent, taking \$5,500 as the average sum required to provide each additional barrel/day of capacity, including both production and the "downstream" needs of transport, refining, and marketing. On present estimates, an outlay of this order would absorb the entire investment effort of the developing regions for one year out of the decade's ten. The need would be still larger if, as seems likely, the industrialized regions become more and more dependent on petroleum exported from the developing countries.

26. Unless unreasonable sacrifices are to be imposed, the financing of the necessary oil investment from private domestic sources will be beyond the capacity of the developing countries. Nor must it be forgotten that the needs of the electric-power industry, which offer a much poorer prospect of foreign financing, will be at least as large. The capital requirement of these two main branches of the energy sector will almost certainly exceed \$30 billion.

27. In theory, it might be possible for the funds needed to meet domestic oil demands to be provided by the govern-

ments concerned. But, almost inevitably, other vital government tasks would suffer. The seriousness of the choice faced by a government seeking to finance its own oil venture is underlined by the likelihood that the establishment of new production capacity alone will cost some \$3,000 per barrel/day. An output of 10,000 barrels a day would thus call for an outlay of \$30 million—without allowing for downstream expenditures needed to establish an outlet for the production. An initial exploration well in conditions such as those of the Middle East and North Africa is likely to cost, all told, as much as \$1 million. By contrast, expenditure of approximately a third of this sum has recently sufficed to pay for a complete electric-power survey in Argentina and a nationwide mineral survey in Vietnam. For the cost of one such well the groundwater resources of Syria are being surveyed, while for less than four times this investment a College of Advanced Technology is being set up in Libya.

28. Moreover, the difficulties to be overcome by most types of government oil enterprise are such that their chances of success are problematical. The risks of total failure in a production venture are so well-known that they need no further emphasis. They make it questionable whether such ventures can ever represent a proper use of public funds—funds for which “value for money” is always and rightly demanded. This gives rise to a danger that a government exploration venture will be starved of funds, so that it will be too short-lived or concentrate for political reasons on the wrong areas. Oil exploration in unfavorable areas and natural-gas ventures without nearby markets have been supported on

the argument that international oil companies are not interested; but this lack of interest can be assumed to arise from an unattractive rate of return.

29. Financing problems may arise even if the search is successful. A program started more than 25 years ago in Nigeria, involving an outlay now totaling some \$275 million, made a commercial discovery in 1956. But the company concerned is unlikely to be able to stop pumping in fresh funds for at least another year, or to recover its capital and achieve a return on its investment for many more years. If this project had not been supported by the inflow of private capital, its slow maturing would have imposed a painful drain on local resources.

30. The construction of a refinery involves fewer risks than a production venture. A refinery cannot be expected to create much additional employment, and an attempt to refine for export may create more problems than it solves. But a refinery to supply a local market, like a paper or cement mill or other plant to process local raw materials, has attractions as part of an industrialization program. In particular, it offers balance-of-payment advantages for which a government may be prepared to pay a premium in the form of higher product prices. Moreover, the increasing volume and diversity of local demand, together with various operating improvements, are reducing the economic handicaps carried by small, market-oriented refineries. In today's conditions, however, this does not mean that a government agency has to undertake the project.

31. In recent years, not only the established international companies but also domestic companies in North America

and Western Europe have made clear their willingness to build refineries in developing countries. Petroleum institutes, cooperatives and other agencies in industrialized countries—sometimes, as indicated above, receiving help from official funds—have also shown an interest in refinery building. Governments of developing countries are not likely to benefit from investing their own funds in plants that could attract foreign resources—particularly if arrangements can be made for title to the refinery to revert to the government after a given period of years.

32. Petrochemical manufacture is another field of increasing concern to governments of countries possessing the necessary natural gas or other raw materials. Carbon black and other relatively simple projects may be feasible in such situations. The more complex type of petrochemical venture is likely to require naphtha rather than natural gas as its raw material, and as such may offer greatest promise if it forms part of a major refining center. Problems of marketing and the need for close meshing with the chemical industry make this a difficult sphere for government enterprises.

33. Specialized types of bulk transportation are often provided by the producer. Thus, long-distance crude or gas pipelines are most readily financed on the basis of throughput agreements with the producing companies. Tankers enjoy much greater flexibility of operation, and government fleets are being established in many developing countries. But this is a highly competitive business and one that requires large initial outlays of foreign exchange. Moreover, with some 7 percent of the world fleet recently laid up or used for carrying grain, and with ships already on order amounting to over 20

percent of the existing fleet, the operation of a new tanker fleet is likely to impose a continuing charge on the economy in the form of flag preferences.

34. Marketing activities normally are undertaken in support of an integrated company's production and refining interests, rather than as an independent venture. This kind of pattern is also being followed by government enterprises, several of which have recently entered the field as an extension of trade agreements under which they are to obtain bulk shipments of imported products. If those supplies prove to be exposed to interruption for foreign policy reasons, the chances of profitable operation, generally poor in marketing at today's price levels, will be further reduced. Profits can, of course, be raised through exercise of the government's power to control prices and limit competing supplies. But in this case the cost to the consumer, in terms of higher priced or less diversified products, must be included in the balance sheet.

### Conclusion

35. Some index of the rising contribution made by the oil industry to the growth of the developing countries is provided by table 3. This shows that, in the period 1951-61, the volume of oil reserves proved in those countries climbed from less than two-thirds to more than three-quarters of the world total. Expansion of the industry in these areas must continue if both local and export demands are to be satisfied.

36. The above discussion suggests that the financing mechanisms of the Development Decade will be marked by diversity and innovation. The scale of the need in the developing countries will itself make

TABLE 3. *Growth of oil reserves: Developing regions and others*

[End-year totals]

	1951		1961	
	Millions of barrels	% of total	Millions of barrels	% of total
<b>Developing areas:</b>				
Asia-Middle East.....	51,300	49.6	188,129	61.6
Other.....	1,946	1.9	10,808	3.5
Africa.....	175	.1	9,710	3.2
Latin America.....	12,711	12.3	24,706	8.1
<b>Total developing areas.....</b>	<b>66,132</b>	<b>63.9</b>	<b>233,353</b>	<b>76.4</b>
<b>Industrialized areas:</b>				
U.S.A.....	27,468	26.6	31,759	10.4
Canada.....	1,377	1.3	4,174	1.4
Western Europe.....	372	.4	1,811	.6
Japan.....	20	.....	60	.....
<b>Total industrialized areas.....</b>	<b>29,237</b>	<b>28.3</b>	<b>37,804</b>	<b>12.4</b>
Sino-Soviet Bloc.....	8,077	7.8	34,252	11.2
<b>World total.....</b>	<b>103,446</b>	<b>100.0</b>	<b>305,409</b>	<b>100.0</b>

Source: U.S.A.—American Petroleum Institute. Canada—Canadian Petroleum Association. All other areas—*The Oil and Gas Journal*.

this necessary. So will the importance of energy in the political and economic picture, and the desire of many governments to build on the broadest possible resource base. Both the oil companies and the governments of the industrialized countries are showing increasing awareness of this new situation.

37. Even so, the availability of traditional forms of foreign capital and the ability to attract it will remain indispensable to any developing country that wishes to stimulate the growth of the oil business. Much of the present outflow of development capital from the industrialized countries comes from public

sources. The economic aid programs of these countries will presumably help to maintain this part of the flow. In the case of oil, however, private capital has carried nearly all the load in the past—the recent United Nations report “Capital Requirements of Petroleum Exploration and Methods of Financing” estimates that 94 percent of the oil now produced in the noncommunist world is accounted for by private companies. Assuming that these companies are able to earn the necessary return on their investment, they can be expected, as in the past, to take the lead in financing the burgeoning energy needs of the developing regions.

---

### FOOTNOTE

<sup>1</sup>In this connection, and throughout this paper, the developing regions are defined to include all of Africa and Latin America and most of the countries of Asia but not Japan. The Communist countries, where there is no international financing from private sources, are excluded also.

# Economics and Design of Smaller Petroleum Refineries

G. B. ZIMMERMAN

*Executive Engineer, Bechtel Corporation, San Francisco, California*

1. In designing petroleum refineries for areas experiencing new industrial development, unusual economic situations are frequently encountered. Capacity is often below that usually considered economic by historic standards. The environment may be changing rapidly and unpredictably. Skilled technicians may be scarce. In these circumstances, development of a refinery capable of economic operation calls for modification or abandonment of many normal design concepts.

2. Techniques which have been used to secure economic operation under these conditions are not all well known or as yet widely used. Their recognition and application, however, are of the greatest importance in those nations experiencing a rapid transition in their industrial economy, in order to avoid waste of critical capital and technical resources.

3. A great deal has been learned in this field in recent years. The following discussion summarizes pertinent information evolved in working with a dozen clients in the course of design and construction of more than 20 completely new refineries in the past few years. Pertinent data are annexed with respect to

several of these representing a low-cost approach to smaller refineries.

## Planning

4. Of the many elements contributing to the economics of petroleum refineries, excepting crude oil cost and product values, all can be controlled to some degree in the planning and design stage of the refinery.

5. First emphasis should be placed on the planning function. The gain in economic return from good planning and a sound concept for the refinery facilities can far outweigh that from normal variations in design for a particular refinery configuration. Such planning to be fully effective must use thoroughly experienced and informed personnel with an adequate budget to carry the work to a sound conclusion. One technique in this area which is proving very valuable is the use of a mathematical model involving all prime variables and solving the resulting matrix to reach the optimum solution for a large number of important decisions. This involves a great deal of specialized skill and the use of a very sophisticated electronic computer, but the gains in both

direct return and directional guidance are rewarding indeed. Those familiar with the more common computer optimization of existing refinery operation will recognize that still greater gains may be obtained in applying this tool to a new installation.

6. In areas experiencing new industrial development, many rapid changes are taking place, the results of which cannot be clearly projected in terms of fuel demands. Attempts to provide physical facilities for long-range growth in product demand therefore involve a double hazard; increased likelihood of error in projection and the cost of capital commitments unused while waiting for demand to develop. Provision can be made in layout and space reservation for future expansion with very nominal capital outlay. Design production, however, should be limited to firmly predictable demands.

7. While planning is vital to obtaining profitable operation, it contains the hazard that excessive time spent in planning delays completion of a project. Such delays result in serious loss of revenue to the operating organization and lack of products for the consumer. This rather obvious need for expeditious handling of planning is not always easy to accomplish. Skill and experience in executing the studies are therefore particularly important.

### **Simplification**

8. Selection of a processing scheme is basic to design and is of prime importance to capital and operating costs. The least complex system will assure lowest first cost, but will limit the flexibility in meeting market demands of quantity and quality of the various products. In many cases, desired product quality is

readily met by simple crude oil distillation followed by catalytic reforming of the naphtha fractions. If high-sulfur crude oils are used, desulfurization of the distillate fuels may also be required. Cracking for gasoline production is required only in those rare circumstances in which low demand for heating oil coincides with gasoline demand high enough to support an automobile for each two or three families in the market area. Cracking may be required in the form of viscosity-breaking to decrease the viscosity of residue when heavy crude oils are used. Some other form of cracking may be used to convert distillates too heavy or waxy for normal use into salable products. For this purpose, hydrocracking, although among the most expensive refinery processes in terms of capital invested per unit throughput capacity, can be attractive because of the large gain in product value over feed value.

9. If a selection can be made among various available feed stocks, yields of all products may be brought to closely balance market demand. This adjustment of feed quality may consist simply of selecting a particular crude oil having the desired gasoline and distillate fuel content, blending two or more crudes for the same purpose, or even preparing a synthetic crude oil by adding needed components from surplus products at a refinery near the crude oil shipping point. An illustration, although unusual, is Example A in Table 1. Here a market calling for gasoline and diesel fuel in the ratio of 4 to 1 with a very small amount of heavy fuel oil was met by charging a mixture of natural gas condensate and crude oil to a simple distillation—reforming refinery. Considerable flexibil-

ity in products was afforded by varying the proportion of crude oil to condensate.

10. Despite freedom in selection of feed and processes, or, more commonly, for lack of such freedom, products from the refinery may not balance market volume requirements. This may occur for only one product, usually heavy fuel. The most economic solution is nearly always to import deficient material or export surplus material to correct the situation.

11. Special products requiring highly complex processes such as lubricating oil or aviation gasoline can rarely be produced at reasonable cost in small to moderate size refineries. Small volume products, even though low in cost as drawn from the process plant, often prove expensive to the refiner. Such materials as solvents, paint thinner, limited runs of special specification fuels and so on place disproportionately high demands on the operating staff, laboratories, and other personnel, and require relatively costly storage, handling, packaging, and shipping. Such products can normally be purchased more economically from large-scale producers. The natural desire of individual oil companies or new nations to make all the products they use can result in cost penalties which are a serious burden to the producer.

## Design

12. With refinery configuration and capacity established, the engineer can proceed to a specific design. Simplification has eliminated some of the larger elements of cost in the process plants. A corresponding reduction in service facilities can also be made, since less demand exists for utilities, maintenance shops, laboratory service, warehousing,

and intermediate products. A simple process configuration combined with small capacity units results in a relatively small area for the process plant so that all processes may be grouped into a compact area with a single control center. Reductions follow in site preparation, underground work, paving, and interconnecting piping.

13. A logical further step is to integrate the utility systems into the operating system so that steam generation, water supply, and air supply are an integral part of the process plant. In addition to the savings from reduced area, such integration makes it feasible to use more waste process heat for steam generation, reflecting savings in fuel cost. Provisions must, of course, permit some steam generation independent of process plants for start-up, shut-down, fire protection, and emergencies.

14. As costs of the process plants are reduced, many of the traditional design standards become questionable. There is less incentive to add capital to obtain long operating periods and short shut-down time. Much of today's mechanical equipment is so well designed that one year continuous operation is routine. Process unit design takes advantage of this in eliminating spare pumps or centrifugal compressors together with their complex piping manifolds and valves, controls, foundations, and space. Safety and shut-down procedures only control spare equipment.

15. An operating philosophy which accepts a short interruption in operation to permit minor maintenance will allow the designer great freedom in minimizing plant equipment. Plants designed to this concept have surprised the old guard in their ease of operation.

16. With 1 or 2 years' operation between major shut-down for maintenance, elaborate platform and ladder structures for maintenance cannot be justified economically. Exchangers and condensers located at grade also reduce the need for steelwork.

17. Expectation of major changes, expansion, or rebuilding of facilities in a few years to meet increased and changing markets is a considerable deterrent to providing long life. Many conventional practices may be challenged on this basis. Large corrosion allowances, alloy piping, galvanized steelwork, and similar standards may be reduced if a 10-year life is contemplated instead of 25 years.

18. Perhaps the most difficult of all steps in reducing design costs is to bring the design engineer to challenge all established practices in the light of a new economic environment. Success in this has produced most gratifying cost reductions.

### Labor Cost

19. In large refineries labor constitutes an item of operating cost second only to capital charges. In smaller refineries, labor cost may actually exceed capital charges. Incentives are great to reduce labor cost.

20. The wage for labor in newly developing countries is low and there is considerable incentive to create as many jobs as possible in starting a new industry. Low hourly rates do not, however, necessarily produce low labor costs, and longer term economics must be considered if maximum benefit is to be derived from the refinery. Most of the jobs in a refinery require a considerable degree of skill and mechanical aptitude. Even in

the most advanced countries, responsible operating assignments are made only to individuals who have had a long training period. Other work in the laboratories or technological control obviously requires advanced training.

21. In a new industrial development, individuals with the necessary experience are scarce indeed and it is not easy to find those with aptitudes for training. At the same time, the fact of industrial growth creates great demand for these individuals. The wage rates, therefore, tend to rise more rapidly for these people, while other benefits are added. Meals, medical care, clothing, recreation, and housing may be required to attract and keep good quality people. Labor cost, including these items, no longer reflects the low hourly rates first visualized. Moreover, these costs have a tendency to increase as time goes on. A pattern of employment, using more people than necessary, on the other hand, often will persist long after the incentive to make jobs has disappeared. The aptitudes and skills needed in other industries are then locked into the one which first offered employment.

22. For these reasons, economic operation of a smaller refinery calls for establishing a minimum operating staff, but with greatest attention to selecting and training this staff before the start of operation. Once established, members of this group become the teachers for their own replacements as needed and for supplying staff for expansion of the refinery or other similar industries. Here again, there is need for experienced competent help in preparing the original operating staff for their work.

23. Much of the responsibility for minimizing operating staff rests on the design

TABLE I. *Low-cost refinery characteristics*

[Typical of those for developing countries]

Example	A	B	C	D
Capacity .....	9,000	31,000	32,000	**55,000
Process units:				
Crude distillation .....	1	1	1	1
Catalytic reforming .....	1	1	1	1
Distillate desulfurization .....				1
Viscosity breaking .....				1
Other .....		(*)		Asphalt
Purchased utilities:				
Fuel, million BTU/hr .....	110	250	330	**350
Electric power, kw .....	1,700	2,100	Generated	Generated
Personnel, total .....	37	90	100	110
Feed type .....	Condensate & Crude oil	Venezuela Crude*	Far-East Crude	Venezuela Crude
Products (no. of grades):				
Gasoline .....	2	2	2	2
Kerosene .....		1	1	1
Diesel fuel .....	1	1	1	1
Marine diesel .....		1		
Heavy fuel .....	1	1	1	1
Other .....		LPG*	Jet Fuel	Asphalts
Capital cost, \$ per daily bbl .....	450	310	300	370

\*Lube oil components imported, blending and packaging facilities provided.

\*\*Normal operation 40,000 BPSD. Fuel consumption corresponds to this rate.

engineer. Integration of process and utility facilities is an important phase. Automation not only reduces the number of hands needed, but also improves control, resulting in better yield and product quality. In some simple operations such as natural-gas plants, automation has permitted unattended operation on night shifts. Table I illustrates the small staffs which have been used in low cost plants.

24. One of the larger labor groups in many refineries is the maintenance crew. In a smaller refinery in which operation is continuous for as long as 2 years, before shut-down, the justifiable maintenance crew would consist of only those who are needed to maintain operation. Major

turn-around, inspection, and repair must then be done by temporary help. In the United States, there is a strong shift to the use of contract maintenance for this occasional work load. Some very large refineries particularly find this to be good economy despite the premium paid the maintenance contractor. In a new industrial area, contracting maintenance may present problems in locating competent help. Good plant design and management allow advance scheduling of the work and a longer than normal turn-around time can be allowed. The incentives are large. Not only is the staff reduced, but indirect costs are lowered for staff facilities, shops, and equipment.

---

## Conclusion

25. The material in Table 1 shows results which have been obtained in the design of several smaller refineries by applying good planning, simplification, design economies, and labor savings. Small size has made the application of these techniques easier, and has thus contributed to economy in capital and operating cost.

26. Throughout this discussion there are references to the need for experienced help in the planning and implementation of a new refinery program. Acquiring good management talent to supply this experience locally may be the most difficult step of all in a refinery program. In

each of the examples cited, this has been accomplished through ownership or partnership with an integrated oil company who were able to supply the priceless combination of talents needed.

27. This discussion has scarcely penetrated the detail which must be dealt with in undertaking a refinery project. It is hoped that it demonstrates means by which a number of major problems may be met and that smaller refineries may be economically built and operated. Where refineries are viewed as a logical necessity, new nations may be encouraged that their own crude oil can be converted to useful products without burdening their economy with unreasonably high cost for this basic energy source.

## Recent Developments in the Design of Small Refineries\*

R. E. BITTNER, *Assistant General Manager*; G. P. BAUMANN, *Engineering Associate*;  
A. R. CROSBY, *Engineering Associate, Esso Engineering, Esso Research and Engineering Company, Madison, New Jersey*

1. It should be the aim of all concerned that the economic development of a less developed area be handled in a manner so that it will be self-sustaining and preferably self-generating. The key to this is that it produce materials and services which are competitive with those available from elsewhere. An essential ingredient of such a development is energy, and thus the energy requirements must, in turn, be met in such a way as to be competitive. As the economy of less developed areas grows and the demand for energy grows, petroleum fuel products are relied upon in most instances to meet the energy needs. The problem of furnishing these products to the economy of less developed areas in an economic and competitive manner is the subject of this paper.

2. There are two ways by which this can be done: (a) Through the import of finished petroleum products, and (b) through the manufacture of such products locally from indigenous or imported crudes.

3. The advantages of off-taking and importing products from large, centralized refining installations are axiomatic.

The cost of energy supplied by this route will be competitive since such products must be priced basically competitively through the free-marketing areas. On the other hand, the route of manufacturing indigenously is not so clear-cut and is fraught with difficulties. Even though crude oil is purchased at competitive prices, the problem lies in the cost of manufacturing products from these crudes.

4. The difficulty arises from the fact that local requirements for products in a less developed area are small—extremely small, in fact—compared to the cumulative product take-off at the large refining facilities from which competitive areas may be obtaining their requirements. Unfortunately, large refineries are not really multiples of small units, but consist of essentially the same pieces of equipment built in larger sizes. Increases in capacity by this route can be obtained at relatively little increased cost and thus the cost of refineries is not proportional to size; rather, the cost increases more slowly than the size increases. Consequently, the larger refineries inherently require less investment and less operating cost per barrel of refined product. This puts the less developed areas, with their

---

\*U.N. Conference paper.

small requirements, at a great disadvantage when going the route of indigenous refining.

5. Sometimes there are compelling reasons for the indigenous refining route—to establish a local industry, relieve unemployment, conserve foreign exchange, etc. Tremendous incentives then exist to overcome the size disadvantage described above. Affiliates of Standard Oil Co. (N.J.)—for example, Esso Standard Eastern—operate in areas such as this and are called upon at times to install small local refineries. It is the aim of the company and its affiliates to do everything possible to overcome the inherent size disadvantage and, as a target, make these installations truly competitive. Consequently, Esso Research and Engineering Co. (E.R.E.C.), their principal research and engineering affiliate, has spent considerable effort in developing principles and concepts which would permit the installation of very small refineries which would meet this target. Many of these principles have been demonstrated conclusively in recent installations, in which the so-called “divisor advantage” of large refineries has been completely eliminated.

6. The solution worked out in simplest terms was to treat small refineries differently from large refineries from both conceptual and engineering standpoints. The first step was to uncover the factors which established the cost of the small refineries. An analysis of many industry refineries showed that the key cost factors could be grouped into two broad categories. The first encompasses those factors or decisions which set the basis for the refinery design—these have been called “design basis decisions.” The second category includes the factors and

decisions made by the engineers who design and construct the refinery—these are called “technical decisions.”

7. Very small refineries, for the purposes of this paper, are considered to be in the range of 2500 to 5000 B/D of products and should be capable of producing satisfactory products, both in yields and quality. The quality and quantity of such products may vary considerably, depending on the location and needs, and on the quality of the crude which can be made available. In terms of physical facilities, a refinery is considered to encompass the functions of crude receipt and storage, converting the crude into finished blend stocks, blending these into finished products, and storing and loading of products for shipment. Utilities, shops, and other associated facilities are also included within the scope of the term.

8. The studies made by E.R.E.C. showed clearly that the design-basis decisions exert a major effect on refinery investment and it is imperative that the effect of such decisions on refinery investment be determined before investment decisions are made. The nature of these decisions and the influence of these on refining investment costs as determined from actual experience are covered below and in figure I. Figure I shows that a potential savings of 35 percent can be obtained if all these areas are decided in such a way as to be favorable to the manufacturing function and if such decisions are exploited by aggressive engineering. In most cases, a good portion of the savings can be captured.

(a) Products—This includes the amount and quality of each product, all of which influence the nature and severity

of the process facilities, as well as such items as utility and chemical requirements, materials of construction, etc.

(b) Quality of Refinery—This area covers the need for paved roads, nice office building, cafeteria, and other items which are unessential to the operation of the refinery itself; the degree to which risk acceptance is obtained; and the extent to which money is spent to meet future contemplated needs.

(c) Product Movement—Arbitrary decisions in handling of products can have a vast effect on costs. These items involve marine terminal design, railroad sidings, storage volumes, marketing terminals, size of shipments, etc.

(d) Location and Site—These fix the cost of the land; the leveling, grading, and filling; the necessity for piles; the availability of local facilities such as utilities, shops, transportation, etc. Local regulations which cover construction codes and water pollution, customs and taxes, are also extremely important.

9. Given a set of carefully established design-basis decisions, it then becomes necessary to apply sharp, imaginative engineering to these decisions in order to extract all of the economic potential available. This involves the following areas:

(a) Process Selection—This requires application of the best process to provide the desired product slate; getting the most out of the crude oil at minimum cost.

(b) Process Design—This area translates the process scheme into specifications which define the plants to be erected. This encompasses many engineering decisions—equipment selection and sizing, plant lay-

out, materials of construction, provision for spare equipment, etc.

(c) Construction—This pertains to the translation of specifications into physical plant and requires efficient management and control to achieve optimum cost objectives. Many decisions are involved affecting the detail design, purchasing, and construction of the refinery; e.g., preparation of the many construction drawings, construction planning (manpower schedule), expediting and inspection of materials, construction management, etc.

10. The results of a recent study by Esso Research and Engineering Co. illustrates the principles outlined above. The study involved building a refinery to market 4,800 bbls./day of salable products. Two basic processing schemes were investigated as alternatives through the study: catalytic cracking (gas oils) and hydroskimming (naphtha catalytic reforming). The 4,800 bbls./day of salable products were made with each scheme, but with different product distribution (see table 1). The investments and operating costs of both cases were essentially the same and compared favor-

TABLE 1. *Product distribution, hydroskimming vs. catalytic cracking, percent of salable products*

	H/S	C/C
LPG .....	2	2
Mo gas .....	25	31
Kero & jet fuel .....	11	14
Diesel fuel .....	24	30
Fuel oils .....	38	22
	100	100

ably with installations of ca. 50,000 bbls./day size. In any particular situation, the case giving the better match to local marketing requirements could be selected, thus resulting in good flexibility in meeting the needs of a given less developed area.

11. Since catalytic cracking refineries have been more expensive historically than hydroskimming, the previous standard catalytic cracking plant (Model IV) was reengineered in detail with remarkable cost savings (50 percent of the Model IV investment). This new unit has been termed the Model V.

12. In this design work, an exact scale model of the onsite facilities was made. Some interesting features are: (a) The entire processing section of the refinery was fitted into a very small area, 80 ft. x 130 ft. (b) All of the equipment was designed as one integral unit. (c) All equipment, except the large towers and connecting piping, was skid-mounted. (d) Packaged utility supply was provided in the unit so that it was self-sufficient from a utilities standpoint.

13. The above illustrates what the engineer can do in a given situation to achieve minimum costs. As indicated earlier, he is greatly helped in this work by the opportunities provided by the design-basis decisions. To clarify this picture, it is desirable to classify the many factors and decisions which set the design basis into one of three general categories: "local," "refiner," and "area-site." This classification is arbitrary in that most decisions are influenced by more than one category. Examples of design-basis decisions are given below:

(a) *Local*

- (i) Industrial planning.
- (ii) Emergency storage.

- (iii) Special product specifications.
- (iv) Customs, duties, taxes.
- (v) Labor education or training.
- (vi) Pollution regulations.
- (vii) Construction codes.
- (viii) Amenities.

(b) *Refiner*

- (i) Products . . . number, quantities, qualities.
- (ii) Product movement and shipment size.
- (iii) Quality of refinery.

(c) *Area-Site*

- (i) Climate . . . temperature, rainfall, hurricane, earthquake.
- (ii) Site-proximity to sea and existing facilities.
- (iii) Site-elevation, soil bearing.
- (iv) Water availability.
- (v) Labor availability.

14. The "local" attitudes, desires, regulations, and planning are established principally by the governments. The generation of a favorable climate in which the refiner and his engineers must work is economically sound. One method to achieve this is industrial planning. The allocation or zoning of land areas for industrial development which meet the needs of industry will help create a favorable climate. Such needs for a refinery are proximity to:

(a) *Transportation*

- (i) Sea.
- (ii) Docks (dry and liquid cargo).
- (iii) Railroads.
- (iv) Roads.

(b) *City*

- (i) Large consuming area.
- (ii) Available labor.
- (iii) Housing.

(c) *Industry*

- (i) Utilities.
- (ii) Shops.
- (iii) Chemicals.

15. Industrial planning can make many of these factors available and attractive. Also, an industrial zone will allow a refinery to be located with other industries so that less self-sufficiency is required.

16. The government's attitude and regulations affecting the refinery are also important. They may, e.g., require additional investment by demands for tankage over and above that required for processing, and for product quality over that actually required. The cost of metering product shipments for customs can vary from a nominal to high, depending on regulations set up by the government. Pollution regulations, construction codes, and amenities vary from location to location. It should go without saying that the refiner is interested in being a good neighbor and in having a safe refinery; therefore, he will automatically adopt safe and satisfactory codes and regulations if none exist. In so far as government codes and regulations are concerned, good ones are those which meet the local requirements and fit the country, refinery site, and size; that is, they are not adopted arbitrarily from elsewhere.

17. The small refiner must think and operate differently from the large refiner. The construction and operation of a small refinery must be turned to advantage. He must make use of the favorable fact that fewer and less sophisticated products are required in a less developed country. On the whole, decisions concerning the number, quantity, and quality of the products required establish the type, amount, and severity of processing. If the number of products are not low, he will be fettered with excessive investment—because each product requires, as a minimum, individual handling for storage, loading, and shipment. Also, he may find it desirable to import certain

finished products to avoid inordinate processing costs. In this case, he can obtain a more economical plant and avoid excess products.

18. The refiner must also consider the quality of the refinery. Here again, the small size can be turned into an advantage. Optional design factors and pre-investment for flexibility, as well as convenience items and seasonal variations, can be reduced since fewer products are produced. Also, in the small refinery, the degree of risk acceptance can be increased. Risk acceptance refers to continuity of refining as influenced by equipment availability and the impact of the loss of a unit or the refinery if a fire or other catastrophe should occur. It is relatively easy to make up the output of a small refinery by importation of products. Self-sufficiency must be reduced by using facilities such as docks, water supply, electric power, shops, warehouses, and offices which are furnished by others or shared with others.

19. The "area" establishes the importance of natural phenomena such as rainfall, temperatures, and presence of hurricanes and earthquakes. These must be accounted for in the design of the facilities. The specific "site" governs the elevation, grading, soil bearing, piling, and layout; and can affect air- and water-pollution facilities. The site proximity to existing facilities and services such as piers, shops, railroads, utilities, and labor also plays a very important role in establishing the degree of self-sufficiency and thus the refinery cost. Every effort by all concerned must be made to have such areas set aside for this use.

20. In short, the "design bases" of a refinery are made up of the numerous decisions formulated by the local government, refiner, and engineer. These de-

---

cisions are influenced by the area and site. With the variability in such items, the best decision for one location may often be the poorest decision in another location. An example of such a situation is found in the selection of cooling medium in the refinery; air, sea water, and fresh water cooling are each optimum for a particular site and climate.

21. In summary, if reasonable and favorable conditions exist in a country, such conditions being generated to a large extent by the local attitude and government, and if these favorable conditions are vigorously utilized by an experienced engineering organization, there is every reason to believe that the costs of an indigenous small refinery can be brought in line with those of much

larger refineries. It is self-evident that the costs will depend on how many factors are favorable, on how well they have been used, and on how well the less favorable decisions are handled. However, it is reasonable to expect—and it has been demonstrated—that small refineries in the size range of 2500/5000 B/D can be built at a cost that compares favorably with the investment of refineries an order of magnitude larger. The operating and product costs will also reflect this investment reduction. It must be recognized that these small refineries are a different breed from the larger refineries and are custom-designed to meet the requirements of less developed countries. This philosophy and approach are essential for success.

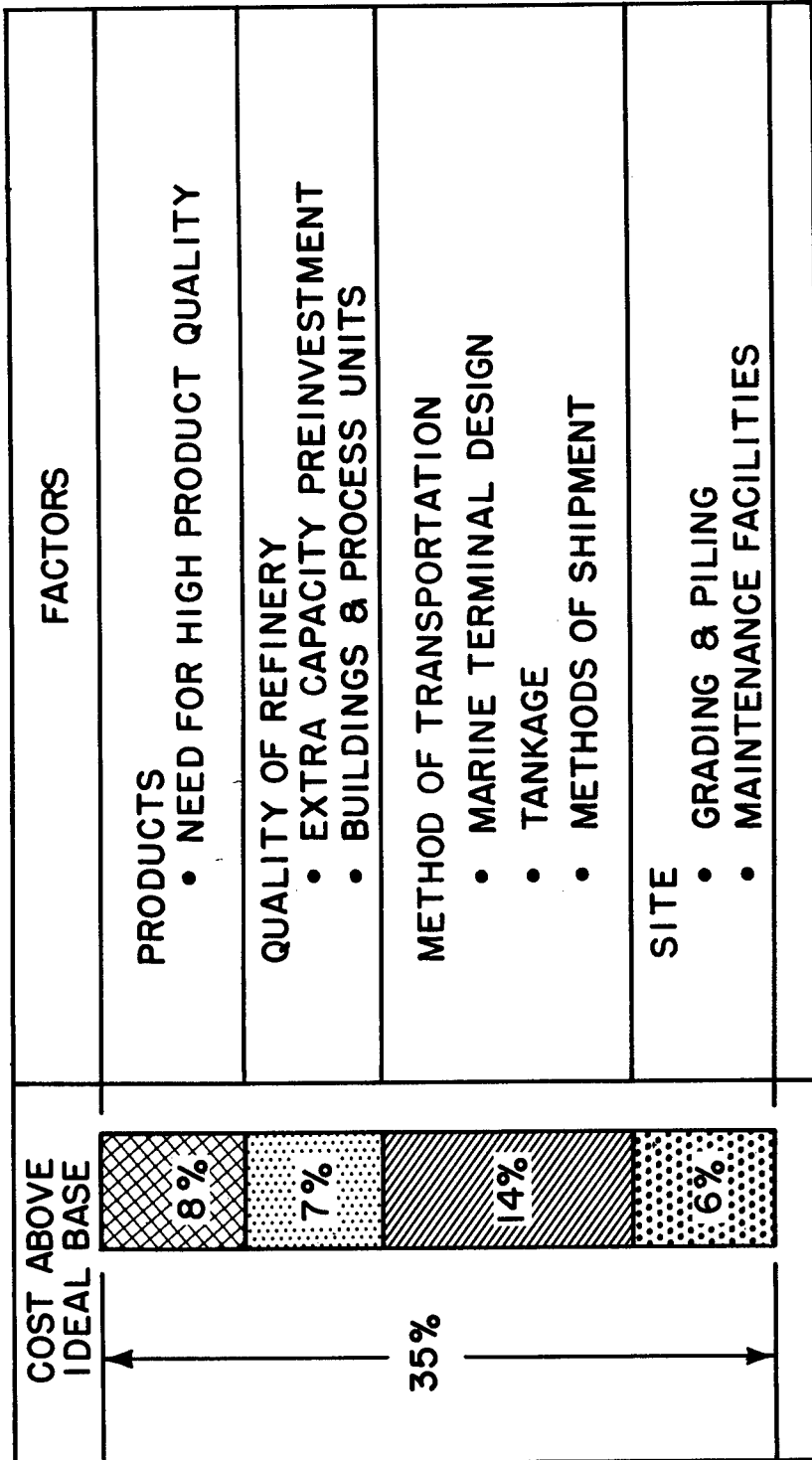

FIGURE 1. Design basis decisions have a great effect on cost of refineries.

# *Nuclear Energy*

## Nuclear Power Technology and Costs\*

FRANK K. PITTMAN  
*Director*

U. M. STAEBLER  
*Senior Associate Director*

*Division of Reactor Development, U.S. Atomic Energy Commission, Washington, D.C.*

### Introduction

1. Nuclear power has now achieved a state of development and experience such that it warrants serious consideration in connection with planning future growth of power systems. There are undoubtedly many situations in the world in which a clear economic justification can be made for nuclear power plants. Likewise, of course, many situations which may appear to be favorable to nuclear power on the basis of a superficial analysis will not be economically favorable when the situation is analyzed in greater detail. Even in areas in which

nuclear power does not appear to be economically justified at the present time there may be good reasons to gain some experience with nuclear power plants now in order to have a solid foundation upon which to build a nuclear-power industry which will be economically attractive in the future. On the other hand, a premature or poorly directed nuclear power-plant construction program can be wasteful of valuable national efforts.

2. It is the intent of the authors to review briefly the status of nuclear power-plant technology based upon experience in the United States with particular reference to possible application of that experience to the needs of less developed

\*U.N. Conference paper.

areas. The definition of "less developed areas" is clearly a relative matter. Some areas of the United States, for example, are less developed than other areas. Thus, some evaluation of nuclear power for less developed areas can be made within national boundaries. Even more important, and certainly more complicated, is the evaluation of nuclear power for countries which are "less developed."

3. Nuclear power has many different energy applications. Its development thus far has been primarily for the production of electricity because this application requires relatively large plants that appear economically favorable to nuclear power. Production of electricity also appears to be the application of most immediate interest to less developed countries. Frequently the distinguishing features of such countries are relatively low per capita income and relatively low per capita consumption of electricity. This observation naturally leads to a common impression that there is a direct correlation between use of electricity and income. A closer look, however, shows that the correlation is not exact. Increased standards of living are not achieved simply by increasing electric-power supply. A low ratio of electric-power consumption per unit of national income, which is characteristic of less developed countries, is the result of an interplay of many factors. These factors include, for example, limited or undeveloped resources, low industrialization with low power demands, and high fuel costs with high electric-generating costs. Figure I (compiled from data given in the United Nations Statistical Yearbook, 1960) is an illustration of the irregular correlation and importance of these factors. Note that

Canada, Norway, and Japan all have higher rates of electricity consumption per unit of income than the United States but their per capita incomes are lower. The general conclusion from such an evaluation of factors contributing to the state of development of an area is that availability and cost of fuel are very important.

4. Nuclear fuel has characteristics which make it unique for equalizing the cost of fuel in various geographical areas. It is natural, therefore, that countries which have been relatively slow in their development because of scarcity or cost of fuel look with interest toward nuclear power.

#### **Status of Nuclear-Power Technology**

5. The results of research and development, design, construction, and operation of nuclear-power reactors in the United States have been widely reported (1-10). This experience includes a wider range of reactor concepts than that of any other country. Nevertheless, the results of work in other countries also are very important and should be considered in the planning of any future program. The class of reactors using ordinary water as moderator and coolant has had the most extensive developmental support in the United States. There are several design variations within the class, extending from those which permit no net steam generation in the core to those which have all steam generated in the core and passed directly to the turbine. Variations in control scheme and fuel management also are available. The specific choice of design and mode of operation should depend upon the size plant required and other considerations

related to the specific application including, of course, the financial arrangement offered for its construction.

6. In the United States current plant-construction bids, fuel guarantees, and applicable Government policies permit construction of plants in the range of a few hundreds of megawatts of electrical capacity which should be competitive with fossil-fueled plants in areas where fossil-fuel costs are 35¢ per million BTU and perhaps even slightly less. In general, the economics of nuclear plants relative to fossil-fueled plants becomes less favorable as the plant size decreases (11, 12). In other words, the fossil-fuel costs at which nuclear power may be competitive decrease with increasing nuclear-plant size. The relatively high proportion of nuclear-power costs which are due to capital costs also makes the comparison somewhat sensitive to the plant-capacity factor to be expected and the fixed-charge rate considered applicable. The currently estimated levels of fossil-fuel costs at which nuclear power could be competitive in the United States, for plants up to 100 MWE, are shown in figure II.

7. Confidence in the reliability and dependability of nuclear plants of the water-moderated and cooled variety is based upon the record established by the three such plants which have now been operated fairly extensively as power producers on utility systems in the United States. These plants are the pressurized water reactors at Shippingport, Pennsylvania (Duquesne Light Company System), and Rowe, Massachusetts (Yankee Nuclear Power Station), and the boiling-water reactor at Dresden, Illinois (Commonwealth Edison Company), (8, 9).

8. The pressurized-water reactor at Shippingport, Pennsylvania, completed

two 1000-hour full-power (60,000 KWe) runs with the first seed of its seed-blanket core in 1958 and three 1300-hour full-power runs with the second seed during 1961. Numerous reactor-plant and core tests as well as training exercises were conducted during these intervals. Despite extensive low-power operation required for test programs and training during operation with the second seed, gross electric-power generation amounted to 514,300,000 kwh—equivalent to operating the plant at full power 70 percent of the time. Shutdowns for maintenance accounted for less than 3 percent of the time. The Shippingport station has followed all system load change demands, and has proved it can be shut down and started up under controlled conditions at a faster rate than any modern conventional power plant on the system of the Duquesne Light Company.

9. The Yankee Nuclear Power Station completed operation with its first core on May 18, 1962, after 8600 equivalent reactor hours at 485 mw thermal.

During this time gross electric-power generation amounted to 1,330,521,000 kwh. This performance is equivalent to operating the plant at full power 68.6 percent of the time. Plant and core test programs limited the plant-load factor, but the reactor was at operating temperature and pressure 90 percent of the time. The start-up of the Yankee plant was accompanied by outages due to steam-turbine vibrations and design modifications to the throttle valves and generator-control systems. However, only about 1 week of outage was directly attributable to the nuclear plant, that being due to valve stem leakage.

10. The Dresden Nuclear Power Station has been in service since April, 1960.

By September, 1962, gross electric-power generation amounted to 1,797,677,000 kwh. There were two unplanned outages attributable to the nuclear plant during this initial operating period. Conditions causing these outages were remedied by design changes to materials in the control-rod drives and in the control blades. Following resumption of operation after the outage ending in December, 1961, including the period to September, 1962, reactor availability has been 94.7 percent, plant availability 92 percent, and plant-capacity factor 85.5 percent. Since part of the steam in this plant is generated in the core and goes directly to the turbine, it is worth noting that radiation surveys have confirmed experience at the Experimental Boiling-Water Reactor and the Vallecitos Boiling-Water Reactor, all of which shows only a negligible amount of turbine contamination caused by radioactive corrosion products from the reactor system.

11. Experience with all three of these plants has shown that shielding has been conservatively designed, and radioactive waste release has been far less than permissible limits. Experience also has demonstrated that each of the reactors is capable of much higher outputs than provided in the original design specification. For example, modifications in the Shippingport plant are planned which will increase its output from 68,000 kwe gross to the equivalent of 150,000 kwe gross, using essentially the same pressure vessel but with a 1-foot extension in height. The power output from the first core at Yankee was increased progressively from 110 kwe to 141 mwe, and operation with the second core currently is authorized at 155 mwe. The rating of the Dresden plant also

progressed from an initial design of 180 mwe to a currently authorized power-level equivalent to at least 200 mwe.

12. Operating experience with these major nuclear power producers is continuing to provide the basis for confidence and improvements in future nuclear-power plants. More plants representing markedly different technologies are nearing their operating phase. Meanwhile, increased experience and volume in fuel fabrication is providing a basis for commercial fuel-cycle guarantees which point toward nuclear fuel-cycle costs of the order of 2.0 to 2.5 mills per kwh in the very near future. These figures are expected to drop to 1.0 to 1.5 mills per kwh within 10 years even with accounting practices that would go with private ownership of nuclear fuel, commercial reprocessing, and recycle of plutonium at fuel value.

#### **Pattern of Nuclear Power Use in the United States**

13. As indicated earlier, the United States has areas representing rather widely differing degrees of development. Therefore, it is of interest to observe the pattern of developing interest in nuclear power. Three different bases for interest in nuclear power are apparent in the United States, excluding interests stimulated by reasons other than evaluation of economic promise.

14. The most prominent basis of interest is in areas which are already highly industrialized to the point where large power plants are warranted but in which fuel costs, for one reason or another, are relatively high. Examples of these areas include the New England states, California, and the North Central states.

15. Next, there is interest in providing nuclear power plants on large integrated power grids but located at the periphery of these grids, where the local power demands are still modest and fuel costs are high because of relative remoteness of the site from fuel resources. This situation is exemplified, for example, by the Big Rock Point Plant of Consumers Power of Michigan and by the Pathfinder Plant of Northern States Power Company.

16. Finally there is interest in nuclear power in very isolated places, even though quite small plants might be required. The outstanding example of this application by the United States is the location of a nuclear power plant of 1500 Kwe capacity at McMurdo Sound, and plans for installation of similar small plants at other sites in Antarctica and elsewhere.

17. Each of these three types of interest is soundly based in terms of attempting to provide most effective use of available energy resources with consideration of the many factors involved in making such evaluations.

18. The long-term interest of the United States in nuclear-power development is to make possible the realization of the full energy potential of nuclear fuels and thus to make it possible for these fuels to provide the Nation's power needs for many centuries. Projections of power requirements against various fuel resources indicate that early in the 21st century the United States should be prepared to have all new increments of power-generating capacity supplied from nuclear plants.

#### **Bases for Interest in Less Developed Countries**

19. The World Power Conference Survey of Energy Resources, 1962 (13) sum-

marizes the situation on total energy resources as follows:

"\* \* \* it is interesting to estimate the coal equivalent of the reserves of the fossil fuels—coal, brown coal and lignite, peat, petroleum, oil in shale and bituminous sand, and natural gas—that could probably be economically recovered. The coal equivalents are 3 million million tonnes for coal, brown coal and lignite, 100,000 million tonnes for peat, 90,000 million tonnes for petroleum, 200,000 million tonnes for oil in shale and bituminous sand, and 90,000 million tonnes for natural gas or a total coal equivalent of about 3.5 million million tonnes for all these resources. This quantity is 700 to 800 times the coal equivalent of the whole of the fuel and energy used annually by the world at the present time \* \* \*

"In addition, there are the enormous amounts of energy to be derived from nuclear fission and probably also from nuclear fusion \* \* \*

"It is thus clear that for the world as a whole there is no shortage of energy. The problem is one of economics. Costs must differ considerably in different areas owing to the uneven distribution of resources and the heavy costs often involved in the transport of materials and energy in their various forms \* \* \*."

20. The ratio of fossil-fuel reserves to the current rate of consumption is put in somewhat different perspective when one recognizes that highly developed areas have a per capita energy consumption rate of about 6 times the world average and that electric-power consumption rates in general are doubling approximately every 10 years. Thus, if all areas were using energy at the same rate as the United States, for example, and

if growth rates continued as at present, the fossil fuels referred to above would be adequate for only three or four decades—comparable to the expected lifetime of a power plant.

21. For the short term the emphasis clearly must be a choice among the alternative fuels to provide the most favorable economics—which, in turn, if properly evaluated, implies the most effective use of resources. The analysis necessary to make that choice generally is not a simple one. It must be made for specific situations by persons having intimate knowledge of pertinent local factors and persons with expert knowledge of the most modern technologies related to the use of the alternate fuels. Enlightened consideration of nuclear power in such evaluations has been greatly aided by the work of the International Atomic Energy Agency, which, in response to requests of various countries, has sent special missions of qualified people to study local situations. Each of these studies results in a fairly detailed report (14, 15, 16). Other important studies of this type have been done by individual countries and at least in some areas, such as India and Brazil, it has been determined that nuclear power is economically attractive now. It is not possible in this paper to do a satisfactory job of digesting the various reports on the applicability of nuclear power for less developed areas, yet these areas represent only a small fraction of those which warrant study. A few general observations can be made, however, which may be helpful in determining whether or not more serious studies are warranted and in avoiding premature optimism and enthusiasm.

(a) Fossil-fuel costs which appear to be high may be artificially imposed; while consideration of nuclear power in

these cases may lead to reduction in fossil-fuel prices, construction of the nuclear plant may not be economically justified when realistic fossil-fuel costs are reflected.

(b) High power costs due to small plants operating a relatively small fraction of the time are not likely to be an attractive situation for nuclear power.

(c) Nuclear power looks most favorable in areas in which other fuel resources are exhausted or are basically costly to provide and which, at the same time, require reasonably large sized plants having power requirements that warrant operation of the plant a large fraction of the time. Thus, the first applications of nuclear power may properly be in the more highly industrialized areas of so-called "less developed" countries.

(d) Nuclear power, because of its minimum requirements for logistic support, may permit economically favorable development of natural resources in areas without established extensive transportation networks or with environmental impediments. This is particularly true if the situation is such that extensive transportation networks can be avoided by on-site processing.

(e) Nuclear power and the potential hazards of radiation associated with it will undoubtedly require special attention to the establishment of national policy and legislation, and to the education of the public in order to obtain public understanding and acceptance. The effects of potential hazards in terms of national policies and public liability may not be susceptible to adequate treatment in an economic evaluation.

(f) The relative requirements of different power systems for foreign exchange can be more important in the final choice than would be evidenced by economic

evaluations based on normal currency exchange rates.

22. The probable impact of nuclear power on foreign-exchange requirements merits further discussion. Consider, for example, an area in which it appears that installation of a million kilowatts may be justified in the 1970's. This situation could be applicable to many of the currently less developed countries, because of the large expansion in power-generating capacity which may be anticipated. Present cost estimates indicate that if this capacity of 1 million kilowatts was installed in units of 50-150 MWE each, choice of nuclear plants, based on current experience in the United States, would result in an increase in capital cost of approximately \$100 million.

23. It is not likely, of course, that the total incremental cost would require foreign currency. The actual amount required would be subject to detailed negotiations between the buyer and the seller. It seems reasonable, however, based on experience to date, to expect that less than half of the incremental cost would require foreign exchange except for a country which has little or no industrial capability in which case, up to three-fourths of the incremental cost would require foreign exchange. For each mill/kwh saved in fuel cost, the nuclear plants would yield a saving of about \$5 million per year. Savings of 2 or 3 mills/kwh in fuel cycle costs seem quite possible. If all fuel (fossil or nuclear) would have to be imported into the area, fuel savings from the nuclear plant could yield reductions in foreign-exchange requirements of perhaps as much as \$15 million per year.

24. In addition, there is the possibility of developing an industrial capability to perform some of the nuclear-fuel cycle

operations, thus further reducing foreign-exchange requirements. The greatest potential in this area is for eventual development of fuel preparation and fabrication of fuel elements. This part of the fuel cycle could correspond to about 1 mill/kwh, or another \$5 million annually for the million-KW installed capacity assumed. The prospects for local reprocessing of irradiated fuel at this level of capacity (corresponding to less than 100 tons per year of spent fuel from reactors fueled with slightly enriched uranium) does not look promising. Similarly, the U-235 enrichment capacity required probably would be too small to be economically attractive. It is very likely, however, that reprocessing services for irradiated fuel will be available in countries with larger nuclear-power installations. In addition, fuel-enriching services will be available on a toll basis, so that full advantage can be taken of purchasing natural uranium on a competitive market. Further, by the 1970's technology is expected to make economically practical the use of plutonium(17) produced in the reactor to minimize the requirements for separative work for U-235 enrichment.

25. It is possible, of course, to defer the need for enriching uranium and reprocessing irradiated fuel by using power-reactor concepts which will operate on natural uranium. There is no question but that such plants can be built and can be made to operate reliably and dependably. Again, it should be possible to make the choice primarily on the basis of comparative economics. Capital costs for nuclear plants using reactors designed to operate on natural uranium are relatively more sensitive to the plant capacity than other nuclear power plant systems.

This is shown in figure III, which gives the effect of size upon the unit capital cost for the D<sub>2</sub>O-natural uranium and the H<sub>2</sub>O-slightly enriched uranium plants based upon best available estimates for plants which could be built today (18, 19, 20).

26. The higher unit capital costs for the D<sub>2</sub>O-natural-uranium plants given in figure III can be explained by (a) the high investment in D<sub>2</sub>O required, (b) the need for somewhat larger cores for natural-uranium reactors, and hence larger investment in reactor plant for the same power output, and (c) the stage of development of the two concepts. While the capital-cost differential may approach zero in very large plants (probably above 500 MWE) as more construction experience is obtained in building D<sub>2</sub>O plants, at the present there appears to be a capital-cost differential (exclusive of heavy water) of about \$160/KWE in sizes of the order of 100 MWE. The cost of heavy water at the price of \$61.60/Kg\* will add approximately \$80/KW, which generally will increase the seriousness of any foreign-exchange problem. The net effect of these capital-cost differentials depends upon the fixed-charge rate used, plant-capacity factor, and various other factors. Even under low fixed charge rates, often associated with public financing, these capital-cost differentials are equivalent to about 2 mills/kwh. Rates associated with private financing would about double this effect. This incremental cost difference in mills/kwh for the capital and fuel is indicated in figure IV. For these comparisons heavy-water-moderated plants are taken as being at least as favorable economically as other natural-uranium-fueled plants. Graphite-mod-

erated systems avoid the cost of heavy water but are physically larger and reactivity limitations shorten the fuel irradiation cycle, tending to increase fuel costs.

27. Fuel-cycle costs for all reactors increase with decreasing size because of neutron leakage, which results in relatively short fuel exposures for natural-uranium-fueled plants and relatively higher enrichments for reactors which take advantage of fuel enrichment. The estimated fuel cost as a function of plant size for the D<sub>2</sub>O-natural and H<sub>2</sub>O-enriched plants is also given in figure IV.

28. The residual value of the fuel discharged from enriched uranium reactors is considerably higher than the cost of the shipment to a processing facility and the processing charges. In this respect it should be noted that, for a shipping charge of \$15/KgU and a processing charge of \$30/KgU, the contribution of these charges to the generating cost is less than 0.5 mill/kwh because of the high burnup of fuel (15MWD/KgU) which can be achieved in reactors using slightly enriched fuel. While there may be somewhat higher shipping charges for return of fuel from, for example, a country several thousands miles from the processing facility, this incremental cost would not be expected to increase the generating cost more than 0.1 mill/kwh over cost estimates based upon shipment within the United States. In the case of natural-uranium reactors, shipping and processing charges for these distances would be expected to exceed the fuel value of the discharged nuclear fuel. Here, the discharged fuel could be stored until a more economically favorable situation developed as regards fuel processing or value of plutonium in the spent fuel.

\*Current price, \$54/kg.

29. The costs which have been presented in this paper refer in most part to costs in the United States. Specific estimates would be required in order to determine what the costs would be in specific less developed nations. In general, in spite of the possible lower wages in the less developed countries, it is to be expected that there will be offsetting costs for skilled foreign technicians, training and organization of domestic skills, and transport of plant components, so that the cost of installing a nuclear plant

in a less developed country will be higher than for the United States. The situation is the same for a conventional fossil-fueled station.

30. The United States will continue to give wide dissemination to information developed in its extensive nuclear-power program and will endeavor to provide such other assistance as may be helpful in arriving at a sound conclusion on the merits of nuclear power in specific countries.

#### REFERENCES

- (1) *Major Activities in the Atomic Energy Programs*, USAEC Annual Report, Washington, D.C. (1961).
- (2) *Development, Growth, and State of the Atomic Energy Industry*, Hearings before 87th Congress, Washington, D.C. (1962).
- (3) Small and Medium Power Conference, 1, 2, IAEA, Vienna, Austria (Sept. 1961).
- (4) *Small Power-Reactors Projects of the USAEC*, TID-8538, AEC-IAEA Report, (Sept. 1961).
- (5) Ritzman, R. W. et al., *Small Power Reactors*, TID-8535, USAEC (Dec. 1960).
- (6) *Nuclear Reactors, Built, Being Built or Planned in U.S.*, TID-8200 (5th Rev.), (Dec. 1961).
- (7) Pittman, F. K., *Nuclear-power development in the United States*, Science 133, 1566 (1961).
- (8) Pittman, F. K., *Power-Reactor Experience*, Nuclear Congress, New York (June 4, 1962).
- (9) Roddis, L. H., Jr., *Operating Experience With Large Nuclear Power Plants in the United States*, 6th World Power Conference, Melbourne (1962).
- (10) Zinn, W. H., J. R. Dietrich, *Power-reactor technology*, 5 USAEC, Washington (June 1962).
- (11) *Power-Cost Normalization Studies*, Report SL-1674, USAEC, Washington (Jan. 1960).
- (12) *Nuclear Power Costs*, Gov (V) INF/38, IAEA, Vienna (Sept. 1961).
- (13) Parker, A., et al., *World Power Conference Survey of Energy Resources*, 1962, World Power Conference, London (1962).
- (14) *Prospects of Nuclear Power in Finland*, Tech. Report No. 2, IAEA, Vienna (1960).
- (15) *Prospects of Nuclear Power in the Philippines*, Tech. Report No. 3, IAEA, Vienna (1961).
- (16) *Prospects of Nuclear Power in Pakistan*, Tech. Report No. 7, IAEA, Vienna (1962).

---

(17) *Plutonium as a Power-Reactor Fuel*, American Nuclear Society Topical Meeting Richland, Washington (1962).

(18) Isakoff, L. (E. I. duPont de Nemours & Company), *Economic Potential for D<sub>2</sub>O Power Reactors*, Report DP-570, USAEC, Washington (Feb. 1961).

(19) Lewis, W.B., *Nucleonics* 18, 54 (Oct. 1960).

(20) Gray, J. L., et al., *Heavy-Water Moderated Natural-Uranium-Power Reactors*, 6th World Power Conference, Melbourne (1962).

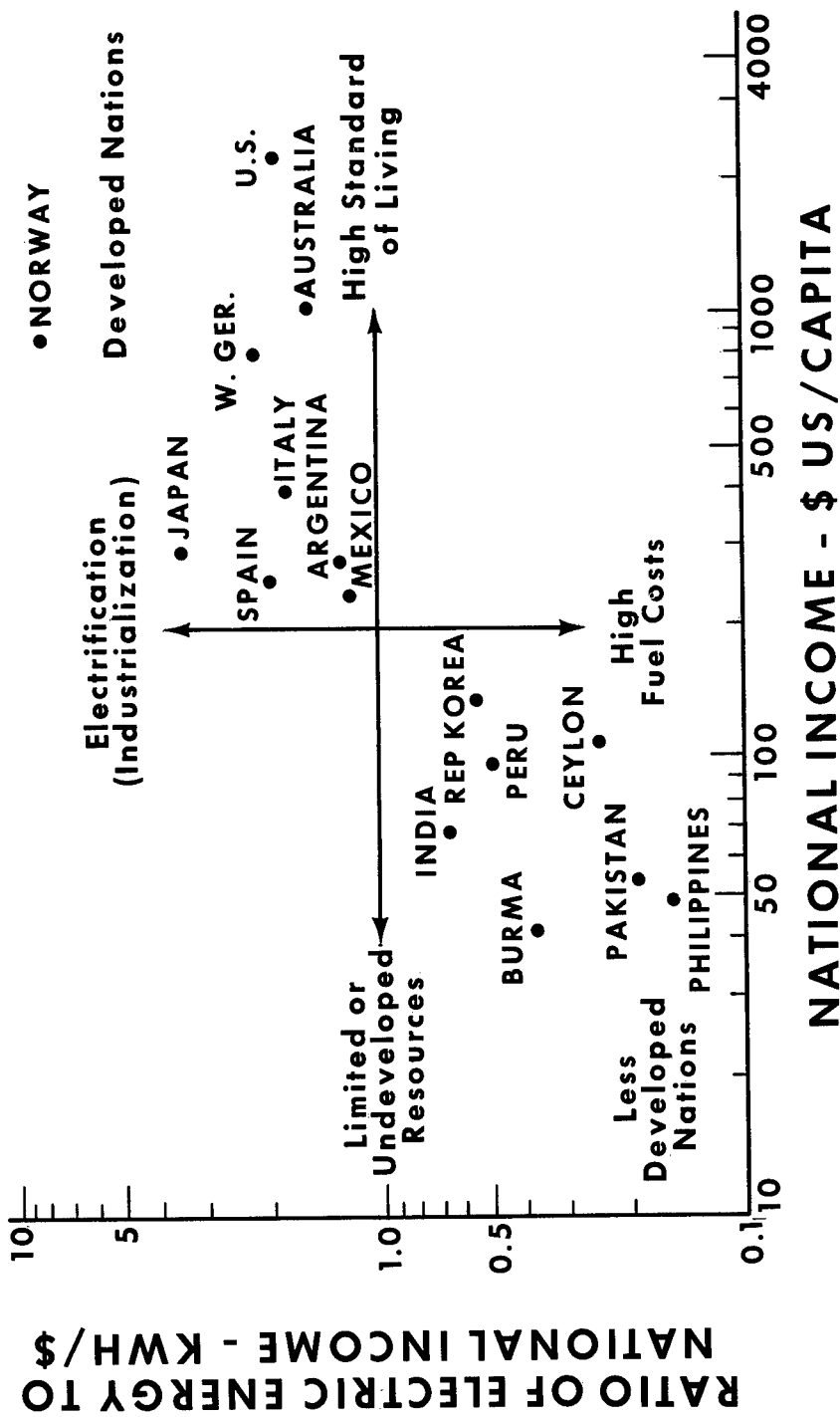

Figure 1. Relation between electric generation and national income.

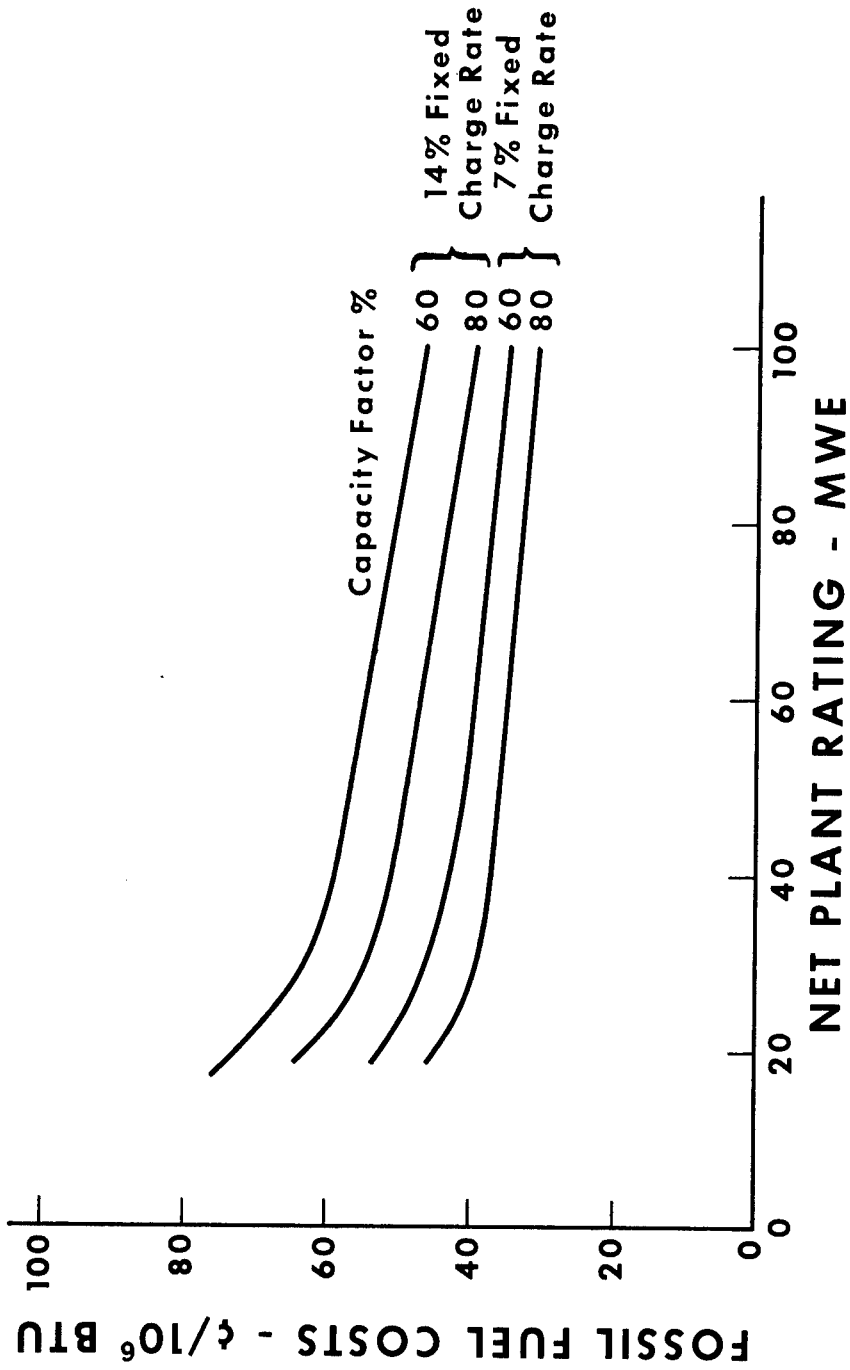

FIGURE II. Estimated level of competitiveness in the United States—nuclear vs. coal electric plants.

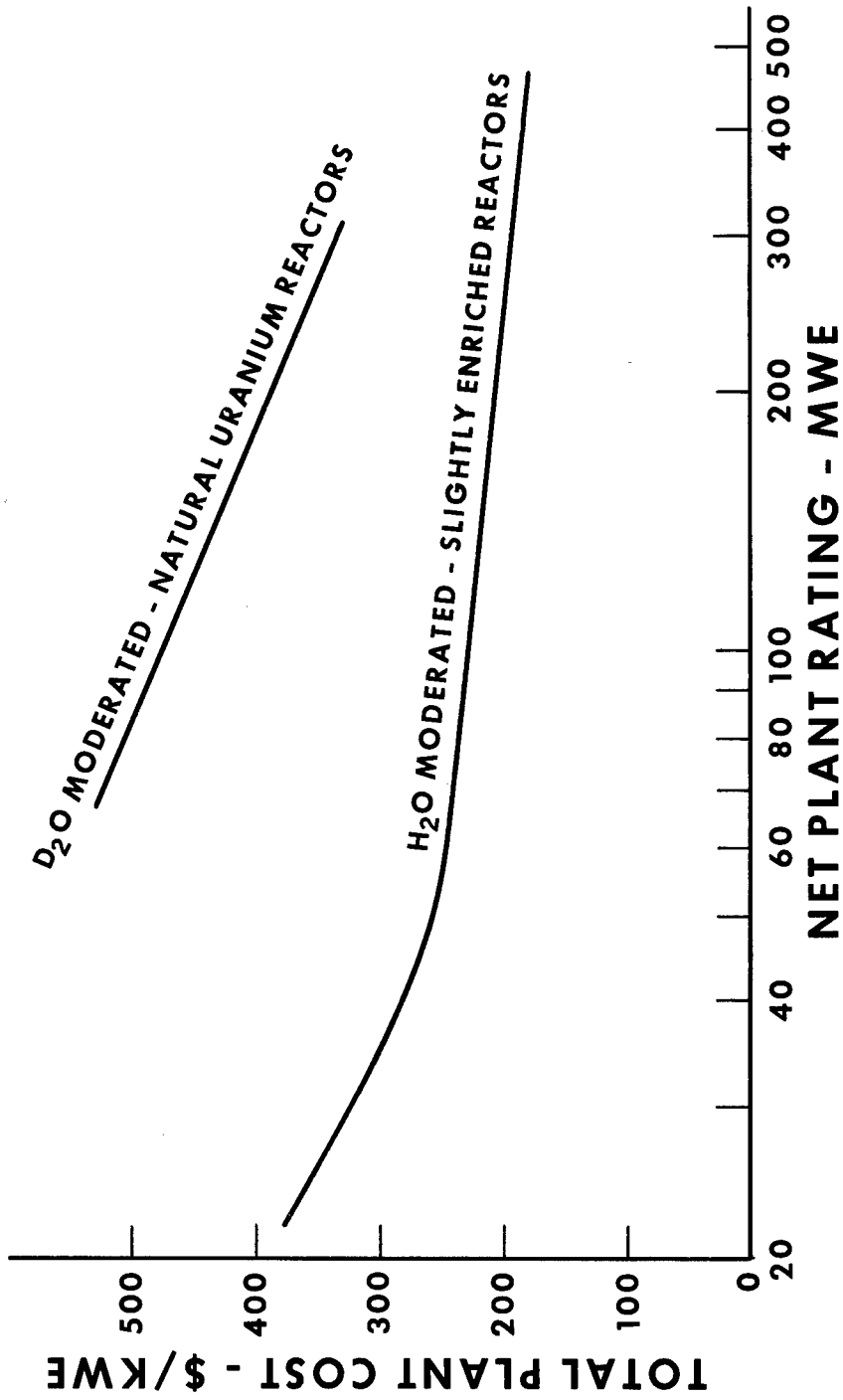

FIGURE III. Capital costs vs. plant capacity (D<sub>2</sub>O natural uranium and H<sub>2</sub>O slightly enriched).

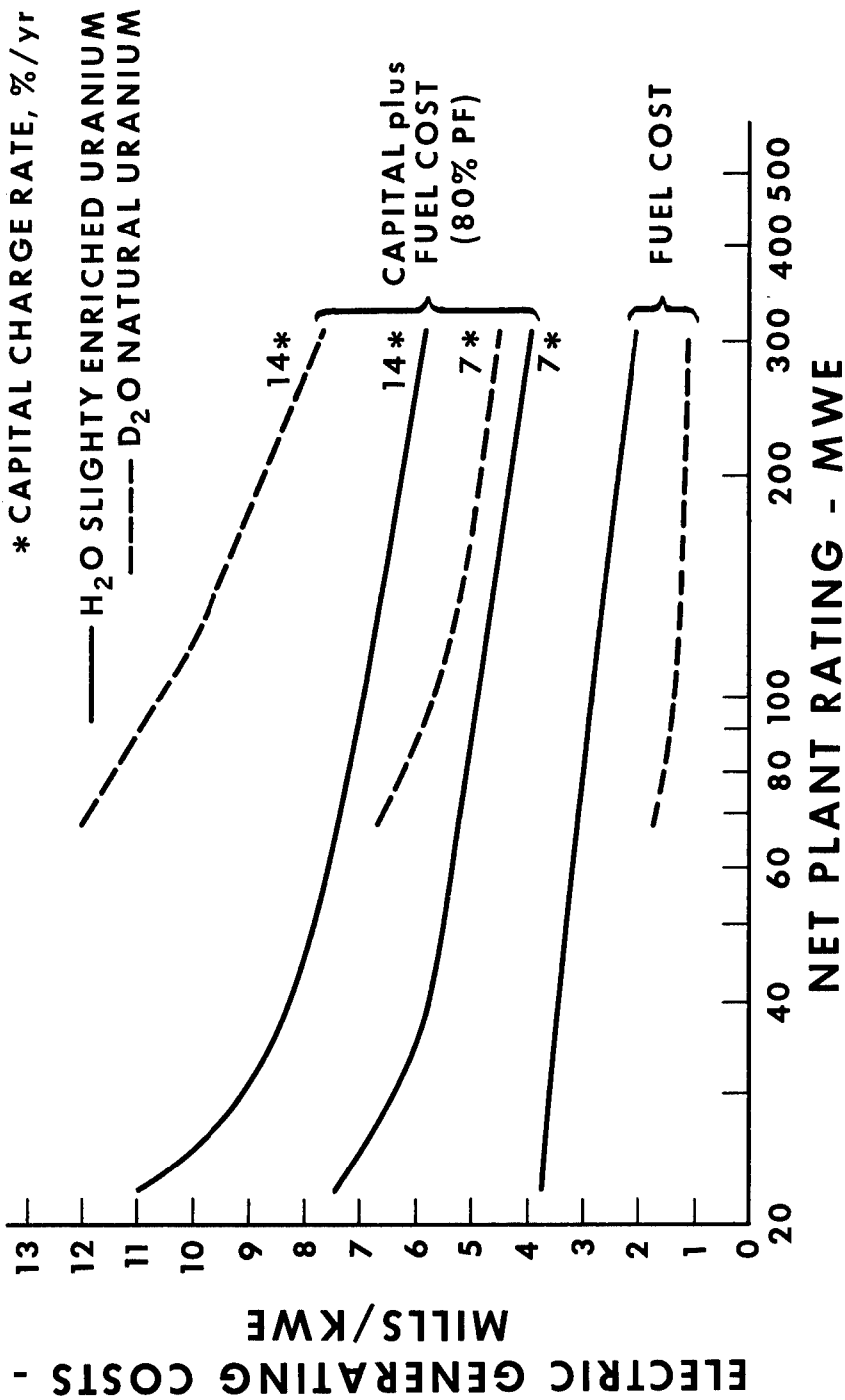

FIGURE IV. Generating cost comparison of H<sub>2</sub>O enriched uranium and D<sub>2</sub>O natural uranium plants.

# *The Economics of Choice Among Alternative Energy Sources*

## Economic Criteria for Evaluating Power Technologies in Less Developed Countries\*

RICHARD A. TYBOUT

*Professor of Economics, Ohio State University, Columbus, Ohio*

### Introduction

1. The object of the present paper is to indicate the general nature of criteria relevant for choice among power technologies in less developed countries. Special considerations for the emergent nations arise out of (a) abundant manpower and in some cases high unemployment, (b) high capital costs, (c) limited public budgets, (d) high foreign-exchange requirements and (e) limited power markets. Each of these considerations is taken into account in the order given. The criteria for evaluation of power projects are developed from the

standpoint of the interest of society or the nation as a whole rather than the management of an individual enterprise.

2. Economic criteria for the introduction of power technologies are similar to the criteria relevant for choice among alternative investments in general. The object in all cases is to provide the maximum benefits to society from the available land, labor, and capital. Benefits are defined by the goals of a society and costs are defined by the natural resources and skills of a people, both of which change over time.

3. For present purposes, only economic goals will be considered in defining benefits. The most important economic goal

\*Extended version of U.N. Conference paper.

is usually an increase in per capita gross national product. A second goal differing in relative importance among different countries is reduction of unemployment (whether concealed or conspicuous).<sup>1</sup> These two goals are combined in equation 1 for a given project,  $i$ .

$$(1) B_i = Y_i + s_i E_i$$

$B$  = net benefits per year, dollars or other monetary units.

$Y$  = increase in annual gross national project as a direct result of output from project, dollars or other monetary units.

$E$  = net increase in employment, man-years.

$s$  = coefficient of conversion, man-years of employment to annual gross national product.

4. Offsetting the benefits from each project are the associated costs. These include capital and the operating expenses, labor, fuel, other materials, and overhead. For evaluation of power technologies, a satisfactory procedure is to include other materials with overhead. The increase in gross national product as a direct result of project  $i$  is then:

$$(2) Y_i = V_i - k'_i + s_i(L_i + E_i) + F_i + O_i$$

$V$  = gross benefit, or value of annual output, dollars or other monetary units.

$k'$  = annual equivalent capital cost, dollars or other monetary units.<sup>2</sup>

$k$  = capital cost, dollars or other monetary units.

$L$  = labor drawn from other productive activities (not previously unemployed), in man-years.

$F$  = fuel consumed per year, dollars or other monetary units.

$O$  = overhead and all other costs per year in dollars or other monetary units. Materials other than fuel, administrative costs and annual decline in salvage value are included. Interest and taxes may or may not be included as indicated by the context.

5. The overhead term in equation 2 includes interest, but not taxes. Taxes are omitted at this point because the object is to determine a contribution to gross national product. Taxes are generally considered to transfer a part of gross national product to government.<sup>3</sup> In certain other contexts, however, as in calculating costs from the standpoint of a business firm, taxes are included as overhead.

6. The most important point to be noted in equation 2 is that man-years of labor have been divided into two parts:  $L_i$  and  $E_i$ . Both are multiplied by the term  $s_i$ , which may be here interpreted as the annual wage rate, since the product produced by labor is evaluated at whatever wage rate is paid in reckoning labor's contribution to gross national product. The significance of splitting labor costs into two parts is seen by substituting equation 2 into equation 1:

$$(3) B_i = V_i - (k'_i + s_i L_i + F_i + O_i)$$

7. Equation 3 shows that the cost of using otherwise unemployed labor for production is cancelled out by the value of increased employment if both are reckoned at the annual wage rates paid. Thus, in using equation 3 to determine net benefits, the two social goals of increased per capita net product and decreased unemployment are being advanced. At the same time, an advantage

will, of course, accrue to projects that increase total employment.

### Net Benefit Maximization

8. A general solution to the problem of choice involves the maximization of the difference between costs and benefits for all the projects considered for installation in a given planning period. This involves the following steps: (a) the choice of projects to be considered whose net benefits appear sufficiently promising at first glance to warrant closer study, (b) the identification of benefits arising from each project and determination of the money value of such benefits throughout the life of the project, (c) determination of corresponding costs for each project, (d) the discounting of both costs and benefits to adjust for differences in time at which they are experienced in each project, and (e) the maximization of the economy-wide excess of benefits over costs, subject to constraints. Step (e) consists in selecting those projects whose net benefits are greatest, within the limits imposed by available budgets, foreign exchange, and any other constraints. The present paper is concerned primarily with steps (d) and (e). It assumes that steps (a), (b), and (c) have already been completed.

9. The net benefits from a project are the difference between its gross benefits, or the value of output, and its costs. Gross benefits may be considered as the total revenue from the sale of output or, if output is to be distributed without charge, as the equivalent value in money terms. When considering benefits from the overall social point of view, proper allowance must also be made for benefits attributable to the project which accrue to others or to society as a whole. For

example, in the case of a hydroelectric project, benefits from flood control are generally estimated.

10. Offsetting the benefits from each project are its costs. These consist of capital and the operating expenses, including labor, fuel, other materials, and overhead. Taxes may be omitted as a cost when judging public projects, but they are included where a choice among projects is being made by a private business organization. As in the case of benefits, proper allowance must be made for costs attributable to the project, which would be borne by others or by society as a whole. Such costs might include labor training and family relocation.

### The Time Element

11. The terms of equation 3 include expenditures with two different temporal characteristics. Capital expenditures,  $k$ , are typically made in a lump sum at the beginning of the project. Operating expenditures,  $L$ ,  $F$ , and  $O$ , are incurred more or less continuously during the life of the project. Gross benefits are received on a relatively continuous basis. Some way must be found to reduce these variables to a temporal common denominator.

12. Two general alternatives are available. Either the capital costs may be spread to an equivalent annual flow comparable with operating expenses, or operating expenses and the value of output can be telescoped to the same point in time as capital expenses. Both approaches have special utility in different circumstances. Consider first the present value method, which reduces all costs, capital and operating, to the same point in time—the present.

13. To illustrate the present value method, assume that all capital expenses are incurred at the beginning of a project and that operating costs are incurred at a fixed annual rate thereafter. The present value of total costs at the beginning of the project with an expected life of  $n$  years is then:

$$(4) \quad \bar{C} = k + \sum_{t=1}^n \frac{D}{(1+r)^t} = k + \bar{D}$$

$\bar{C}$  = present value of total costs (henceforth, the overhead bar will be used to denote present values), dollars or other monetary units.

$\bar{D}$  = total operating expenses,  $sL + F + O$ , dollars or other monetary units, per year.

$r$  = rate of time discount.

$t$  = a running subscript indicating the number of years that have passed since the initial investment.

14. Equation 4 shows operating expenses each year divided by a higher power of  $(1+r)$  and the whole series of resulting values summed over the life of the project. The result is the present value of operating expenses,  $\bar{D}$ .

15. More complicated expressions result from other patterns of operating and capital expenditures. If values of  $D$  are expected to change in a predictable way, a dated variable  $D_t$  can be used in place of  $D$ . If construction is expected to take  $m$  years and plant operation begins on year  $m$ , the term  $k$  can be made a dated variable. These changes are indicated in equation 5:

$$(5) \quad \bar{C} = \sum_{t=1}^m \frac{k_t}{(1+r)^t} + \sum_{t=m}^{m+n} \frac{D_t}{(1+r)^t} = \bar{k} + \bar{D}$$

Other kinds of changes are required for repeating patterns of replacement and for different service lives of capital components.

16. Gross benefits are time discounted and summed to give present values in the same way. Thus, if gross benefits are expected to continue at the same rate for  $n$  years:

$$(6) \quad \bar{V} = \sum_{t=1}^n \frac{V}{(1+r)^t}$$

Returning to the assumed form of costs used in equation 4, the present value of net benefits is then:

$$(7) \quad \bar{B} = \bar{V} - \bar{C} = (\bar{V} - \bar{D}) - k$$

17. The quantity  $(\bar{V} - \bar{D})$  is the present value of net cash flows, assuming that  $V$  and  $D$  represent cash payments. If real values of  $V$  and  $D$  are used instead, the interpretation is similar.  $(\bar{V} - \bar{D})$  then represents the present value of net annual gains from the project after the investment  $k$  has been made.

18. The reason for time discounting the net annual gains (or net cash flows) is that these are net gains in the future. Investment of the sum  $k$  today is expected to give rise to a stream of gains in the future, discounted to reflect the disutility of waiting and the uncertainties of the future. When  $B=0$ , the discounted stream of net benefits is just sufficient to justify the investment  $k$ . When  $B$  is greater than zero, there is a net benefit over and above all costs of the investment.

#### Annual Flow Method of Comparing Costs

19. In the special case where  $V$  and  $D$  are constant annual flows each year,

where  $k$  is incurred at the beginning of the project and where a given rate of time discount,  $r$ , can be assumed to hold for the duration of the project, an annual flow approach can be used. Where an annual flow is appropriate, it has conceptual and computational advantages, as will be clear from later discussion.

20. The flow equivalent of present value can be found by dividing through equation 7 by

$$\sum_{i=1}^n \frac{1}{(1+r)^i};$$

$$(8) \quad B = V - D - k \left( \sum_{i=1}^n \frac{1}{(1+r)^i} \right)^{-1}$$

$$= V - D - k'$$

Equation 8 is in a form analogous to that commonly used when depreciation is included as a cost of capital, and  $k'$  is an annual equivalent charge analogous to depreciation. Indeed, it can be shown that  $k'$  is mathematically equivalent to the capital-plus-interest charge with the sinking-fund calculation of depreciation,<sup>4</sup> though the two are derived with different economic assumptions. Sinking-fund depreciation of capital assumes a recovery and reinvestment of revenues;

$$(9) \quad V - D = \frac{k(1+r)^n}{1 + (1+r) + (1+r)^2 + \dots + (1+r)^{n-1}}$$

The rate of time discount,  $r$ , may be considered the same as the rate of interest for present purposes (see paragraph 21). Then, the numerator on the right-hand side of equation 9 is the value of the investment  $k$  plus compounded interest through year  $n$ . The denominator is the amount by which  $(V - D)$  would need to be multiplied if each year's net gain were reinvested at the same rate of interest. By the time year  $n$  is reached,

whereas equation 8 is intended as no more than a device for determining benefits on an annual basis so that costs of projects with different expected lives can be compared. A second method of calculating depreciation, the straight-line depreciation method, is to be avoided when making cost comparisons between projects for its computational inaccuracy, if for no other reason.<sup>5</sup> The same is true of still other methods of calculating a depreciation cost of capital.

21. The justification for using equation 8 is that it gives a basis for ranking projects of different expected lives according to a standard of infinite replacement to be explained later (see paragraphs 31-33). There is no implication that  $k'$  represents true annual capital costs nor can it be correctly argued that any of the depreciation methods do so either. Capital cost  $k$  is not incurred annually, but only at the time of investment. Interest on capital is, however, an annual cost and is implicitly included in equation 8.

22. To see that equation 8 includes interest implicitly, consider the case where  $B = 0$ . Then, expanding the last term in equation 8 gives:

the total value of  $k$  plus interest has been received in net gains.

23. Among other things, equation 9 suggests that the time rate of discount is the same for the investors and the receivers of the net gains. For this reason, the present value method of comparing costs with different time profiles (and its annual-flow equivalent discussed here) is well-suited for the case in which public projects are undertaken out of tax

receipts. Society is both the investor and the net gainer. The time rate of discount is the same as interest that society is paying to itself.

### The Rate of Time Discount

24. If capital is obtained by borrowing, then the rate of time discount is the rate of interest on the loan. If capital is obtained by taxation, a more difficult problem is encountered. No interest is explicitly paid on capital obtained by taxation, but governments acting on behalf of their people will wish to invest with regard for the time preferences of individuals.<sup>6</sup>

25. Two kinds of considerations are relevant: (a) the preferences of individuals based on their own utilities as affected by personal consumption and work patterns and (b) collective needs as seen from an organic view of society. On the basis of certain economic assumptions described in Appendix B, a social rate of time preference that accords with individual rates of the first type can be found as the weighted harmonic mean of the time preferences of the individuals who are expected to gain as a result of the project. A social rate of time preference that accords with an organic view of society would take account of the welfare of future generations as well as individuals living today. Such a rate of time preference would seem to require that individual taxpayers be willing to sacrifice some of the satisfactions they anticipate in their lifetimes on behalf of future generations, but there is no precise economic formulation known to the author that will reveal the empirical magnitude of this time preference. It is a matter on which governments must make a decision with full recognition of the implica-

tions of different time preferences on the choice among public projects.

### Example of Project Selection Using Annual Flows

26. The implications of the annual flow method are illustrated in table 1, which demonstrates the individual and joint effects of differences among three hypothetical power projects in regard to capital costs, operating costs, useful lifetimes, and rates of time discount. The assumed values used for comparison are shown in Part A of table 1. The three projects include a hydro-plant, a steam-plant, and a diesel plant. Of these, the hydro plant is the most capital intensive and has the lowest operating costs, and the diesel plant is at the other end of the scale in both of these regards. Although the particular values chosen for the example are hypothetical, they are not unrepresentative of actual conditions at many places around the world. The example is intended only as an illustration of methodology, and not to provide a basis for judgments regarding the relative economic merits of possible power-plants either at particular locations or in general.<sup>7</sup>

27. Part B shows a comparison of annual flows, including annual equivalent capital-flow costs for each of the three technologies. Calculations follow equation 8. The principal point to be noted is the increase in the relative merits of the less capital-intensive technologies, particularly diesel, as higher time rates of discount are considered. The hydroelectric facility continues to show greatest net benefits throughout the range of rates of time discount used in the table, but the effect of its great capital intensity is clearly apparent in narrowing

TABLE I. Illustrative examples of production costs and net benefit calculations for three alternative powerplants of 10,000 kw capacity each. Assumed to operate 5,000 hours a year

PART A. ASSUMED VALUES

Plant	Capital cost, $k$ (dollars)	Expected lifetime, $n$ (years)	All operating costs (mills per kwh)				Annual operating cost, $D$ (dollars)
			Total, $D$	Labor, $L$	Fuel, $F$	Overhead, $O$	
	(1)	(2)	(3)	(4)	(5)	(6)	(7)
Hydro.....	5,000,000	50	1.0	0.8	0.0	0.2	50,000
Steam.....	2,000,000	30	8.2	2.2	5.8	0.2	410,000
Diesel.....	1,000,000	15	8.8	1.0	7.6	0.2	440,000

NOTE: Gross benefits,  $V$  (in the present case gross revenue) are assumed to accrue at the rate of 20 mills per kwh. The total value of annual output is  $10,000 \times 5,000 \text{ hours} \times \$.02/\text{kwh} = \$1 \text{ million}$ .

PART B. ANNUAL FLOWS (thousands of dollars)

Plant	Rate of time discount=0%				Rate of time discount=5%				Rate of time discount=10%			
	Gross benefit, $V$	Capital cost, $k'$	Operating cost, $D$	Net benefit, $B$	Gross benefit, $V$	Capital cost, $k'$	Operating cost, $D$	Net benefit, $B$	Gross benefit, $V$	Capital cost, $k'$	Operating cost, $D$	Net benefit, $B$
	(1)	(2)	(3)	(4)	(5)	(6)	(7)	(8)	(9)	(10)	(11)	(12)
Hydro.....	1,000	100	50	800	1,000	274	50	676	1,000	505	50	445
Steam.....	1,000	67	410	523	1,000	130	410	460	1,000	212	410	378
Diesel.....	1,000	67	440	493	1,000	96	440	464	1,000	132	440	428

PART C. PRESENT VALUES (millions of dollars)

Plant	Rate of time discount=0%				Rate of time discount=5%				Rate of time discount=10%			
	Gross benefit, $\bar{V}$	Capital cost, $k$	Operating cost, $\bar{D}$	Net benefit, $\bar{B}$	Gross benefit, $\bar{V}$	Capital cost, $k$	Operating cost, $\bar{D}$	Net benefit, $\bar{B}$	Gross benefit, $\bar{V}$	Capital cost, $k$	Operating cost, $\bar{D}$	Net benefit, $\bar{B}$
	(1)	(2)	(3)	(4)	(5)	(6)	(7)	(8)	(9)	(10)	(11)	(12)
Hydro.....	50.0	5.0	2.0	43.0	18.3	5.0	0.9	12.4	9.9	5.0	0.5	4.4
Steam.....	30.0	2.0	12.3	15.7	15.4	2.0	6.3	7.1	9.4	2.0	3.9	3.5
Diesel.....	15.0	1.0	6.4	7.6	10.4	1.0	4.6	4.8	7.6	1.0	3.3	3.3
Diesel with replacement.....	30.0	2.0	12.8	15.2	15.4	1.5	6.8	7.1	9.4	1.3	4.2	3.9

Source:

Part A values assumed, except that column (7) derived as product of column (3)  $\times$  50,000,000 kwh, the assumed annual output of each plant.

Part B values derived as follows:

Columns (1), (5), and (9)—See Note to Part A.

Columns (2), (6), and (10)—Derived by dividing capital cost figures from column (1),

Part A, by discount factor  $\sum_{t=1}^n \frac{1}{(1+r)^t}$ . By simple algebraic manipulation, it can be shown that

$\sum_{t=1}^n \frac{1}{(1+r)^t} = \frac{1-(1+r)^{-n}}{r}$ , the expression generally used for present value of annuity in

mathematical tables.

Columns (3), (7), and (11)—Annual operating costs are assumed to be constant over the life of each plant, hence these values are the same as those in column (7), Part A.

Columns (4), (8), and (12)—Derived from preceding three columns.

Part C values derived as follows:

Columns (1), (5), and (9)—Annual gross benefit cumulated over the lifetime of each plant and discounted at the indicated rate.

Columns (2), (6), and (10)—Since capital outlay is assumed to be made at the initiation of the project and in one lump sum, the present value is equal to the actual outlay as shown in column (10), Part A, except for the "diesel value with replacement" figure which also includes the present value of a second diesel plant costing \$1 million installed 15 years later.

Columns (3), (7), and (11)—Derived as the present value of the annual operating cost figures at the indicated rate, i.e., multiplied by discount factor.

Columns (4), (8), and (12)—Derived from preceding three columns.

the net-benefit differences. At still higher rates of time discount, the diesel plant would actually result in greater net benefits than the hydroelectric plant. The small difference in capital intensity, or relative proportion of capital to total costs, between steam and diesel accounts for the reversal in the relative ranking of these two technologies between 0- and 5-percent rate of time discount. For rates of discount in the range of 2 or 3 percent, steam would result in greater net benefits than diesel.

28. A different result could have been obtained if different gross benefits had been assumed. For example, if the hydroelectric plant could only be constructed in a remote area with a low demand for electric power, or if stream flow were so irregular and output quality so poor that power could only be sold at low rates, the value of output might be only 10 mills per kilowatt-hour at the

hydro-plant busbar. Annual gross benefits for the hydro project would only be \$500,000 and there is no interest rate at which it would be preferable to either of the other plants.

### Comparison of Present Values With Annual Flows

29. Part C of table 1 shows the same comparisons as Part B, but on the basis of present values, following equation 4. Consider the first three lines of Part C. The ranking of the three projects is changed from Part B at the 5 and 10 percent rates of time discount between the steam and diesel projects. The reason is easiest to see at the zero rate of time discount. As shown in column (4) of Part C,  $\bar{B}$  is more than twice as great for steam as for diesel power. This is because the steam project lasts twice as long as the diesel project. At the zero rate

of discount, no account is taken of differences in cost due to the passage of time, and the greater longevity of the steam project has an unqualified effect. Annual differences in net benefits are not great between the steam and diesel projects, but net benefits accumulate over twice as long a time for the steam project. The longer life of the steam project is thus responsible in large degree for its comparatively better showing than diesel at the 5- and 10-percent rates of time discount.

30. The fourth line of Part C shows present values for two diesel projects, the second to be installed 15 years after the first, resulting in a combined total life of both diesel installations equal to the life of the steam project. (It will be noted that the value of capital continuously decreases due to time discounting of the second project.) If line 4 is used to represent the diesel facilities and is compared with line 2 representing the steam facilities, then the same ranking of the two projects results as in Part B, within the rounding error of the figures. (The apparent difference at the 5 percent rate of discount is due to rounding.)

31. If the same sort of comparison were made between the hydroelectric project and either of the other two projects, it would be necessary to use multiple replacements of both in order to make the replacements terminate after the same number of years. An alternative is to calculate the present value of infinite replacements and compare projects on this basis.<sup>8</sup> As shown in Appendix C, the ratio of present values so calculated would be the same as the ratio of the annual values calculated using equation 8.

32. The present value of infinite replacements makes no assumption of annual equivalent costs, but takes present

values of a series of true capital investments,  $k_t$ . The justification for using the annual equivalent capital cost,  $k'$  is therefore that when net benefits are calculated with  $k'$ , projects can be compared on the same ratio scale as obtained by finding the present values of the same projects with infinite replacement. By the use of equation 8, projects of different life and different time profile are reduced to a comparable basis for comparison.

33. This does not mean that annual flows afford the best basis for comparison of different technologies in a practical situation. The fact that a ranking by annual flows is equivalent to a ranking with infinite replacement should be sufficient to cast doubt on the annual flow approach except for very limited situations where infinite replacement is a useful assumption as, for example in the work cited by footnote 8.

### The Problem of Choice

34. The choice of one technology in preference to another is usually made from the viewpoint of a single annual budget, not from a stream of costs and benefits the equivalent of which is infinite replacement. When comparisons of net benefits are made from a fixed point in time, the fact of greater longevity of one project over another is a point in favor of the longer lived project.

35. Secondly, the size of the annual budget from which expenditures are made on power projects is generally limited by a variety of factors outside the confines of the present discussion. Any project that gives a positive value for annual net benefits is worth the money put into it if there is no other use for the money. Actually, of course, there are usually other uses for the

money, and so the problem becomes that of somehow taking account of foregone alternatives. For present purposes, it is necessary to avoid a part of this problem by taking as given a sub-budget devoted exclusively to power projects. A remaining part of the problem which cannot be avoided, however, is the apportionment of the scarce funds in the sub-budget among power projects.

36. A third consideration is that foreign exchange often exercises an equally effective constraint on the choice of projects. Thermal-power generating equipment, for example, may be available only through imports. This being the case, limits on foreign exchange must be considered in the same way as budgetary limits on investment funds. A related, though different, problem arises when foreign exchange is used for fuel imports.<sup>9</sup>

37. Other constraints arise from complementarities and incompatibilities among power projects. As an example of complementarities, it might be preferable to install both a diesel and a small steam power plant in preference to a large single steam plant of the same total capacity in order to take advantage of the suitability of the two smaller plants to varying load factors in the power system. In such a case, the two smaller plants are complementary. Incompatibility, on the other hand, is reflected in the physical impossibility of constructing two different hydroelectric plants at the same site or the economic unsuitability of building two different power plants to satisfy the same demand.

38. Following a method developed by Steiner,<sup>10</sup> the considerations listed in the foregoing paragraphs can be included in the analysis by ranking power projects according to equation 10. The derivation of equation 10 and of the method in

which it is used is given in Appendix D. The method is presented here from the viewpoint of public project planning in an economy with an important private sector. Appendix D also shows adaptations of the method for project selection in an economy without an important private sector and for project selection within a private business firm. As made clear in Appendix D, the double subscript provides a way of taking account of compatibility requirements and complementarities.

39. The method is based on a recognition that funds available for public power projects and foreign exchange have productive uses elsewhere. The object is to choose projects in such a way that productive uses for power are more valuable than the uses elsewhere. With this end in view, the economy is divided into three sectors. Sector 1 consists of all public projects considered for support from a given budget or subbudget. Sector 2 consists of all private projects that might use foreign exchange. Sector 3 consists of the list of inchoate undifferentiated public projects (backlog projects) on which expenditures would be made if the choice were extended beyond Sector 1.

$$(10) \quad \bar{Z}_{ij} = \bar{B}_{ij} - (u - vv_0)k_{ij} - vh_{ij}$$

$\bar{Z}_{ij}$  = adjusted present value of net benefits of project  $i$  in providing services  $j$ .

$\bar{B}_{ij}$  = present value of net benefits of project  $i$  in providing services  $j$ .

$u$  = present value of net benefit per dollar or other monetary unit of funds spent on any other public power projects (sector 3 projects) outside the list of projects explicitly considered.

$v$  = present value of net benefit foregone in sector 2 per dollar or other monetary unit of foreign exchange used in public projects.

$v_o$  = foreign exchange (measured in dollars or other monetary unit at official exchange rates) required per dollar or other monetary unit of sector 3 projects.

$k_{ij}$  = capital cost in dollars or other monetary units of project  $i$  in providing services  $j$ .

$h_{ij}$  = foreign exchange (measured in dollars or other monetary units at official exchange rates) used for capital goods in project  $i$  in providing services  $j$ .<sup>11</sup>

40. The meaning of the two corrective subtractions in equation 10 is best understood in the light of the preceding paragraph. Consider first  $vh_{ij}$ : The amount of foreign exchange  $h$  used on project  $ij$  is multiplied by the value of foreign exchange in its alternative uses in sector 2 and the product is subtracted from the present value of net benefits. This operation ensures that foreign exchange used in sector 1 projects will provide at least as much present value of net benefits to the economy as would the same amount of foreign exchange in sector 2. Otherwise the subtraction might make  $\bar{Z}_{ij}$  negative and disqualify project  $ij$  from further consideration.

41. The second expression  $(u - vv_o)k_{ij}$  has analogous significance for projects in sector 1 as compared with sector 3. The term  $u$  is analogous to  $v$  in that, when multiplied by  $k_{ij}$ , the result is the present value of net benefits that would be obtained by use of the same funds  $k_{ij}$  in sector 3 rather than sector 1. The product

$vv_o$  is a corrective to allow for the fact that sector 3 projects would consume some foreign exchange and, to the same extent, they are overvalued when their consumption of budgetary funds alone is considered.

42. After both the budgetary ( $k$ ) and foreign exchange ( $h$ ) correctives have been applied, the adjusted present value of net benefits,  $\bar{Z}$ , is compared for each project  $ij$ . The projects are then ranked in decreasing order of  $\bar{Z}$  values and a choice from among them is made in such a way that the budget is exhausted and no incompatible projects are chosen.<sup>12</sup> In the course of making the choice, large and small projects may reverse order of present value of net benefits according to the relative importance of the budgetary and foreign-exchange limitations in each case. The point is illustrated by the example shown in table 2, which is an extension of the example in table 1.

43. Table 2 uses the same present values for the same three power technologies as in the first three lines of Part C, table 1 at the 5-percent rate of time discount. Part A of table 2 assumes the following values for the coefficients:  $u = 0.7$ ,  $v = 0.7$ ,  $v_o = 0.14$ , giving  $(u - vv_o) = 0.6$ . To get some idea of a normal value of  $u$ , note that  $u$  is of the form

$$(11) \quad u = \frac{\bar{B}}{k} = \frac{\bar{V} - \bar{D}}{k} - 1$$

Thus, with  $u$  of 0.6, the present value of cash flows,  $\bar{V} - \bar{D}$ , is 1.6 times capital cost,  $k$ . On the other hand, it will be noted that the technologies used in our example give the following ratios of present value of cash flows to capital cost at the 5-percent rate of time discount (calculated from table 1): hydropower, 3.5; steam, 4.6; and diesel, 5.8. These

TABLE 2. *Adjustment of present value of net benefits*

[Figures are in millions of dollars except for the coefficients  $(u - v_0)$  and  $v$ . Calculations are based on  $r = 5$  percent]

PART A

$(u - v_0) = 0.6, v = 0.7$

	Hydropower	Steam	Diesel
Net Benefits, $\bar{B}$ .....	12.4	7.1	4.8
$(u - v_0)k$ .....	$0.6 \times 5.0 = 3.00$	$0.6 \times 2.0 = 1.2$	$0.6 \times 1.0 = 0.6$
$vh$ .....	$0.7 \times 0.3 \times 5.0 = 1.05$	$0.7 \times 0.8 \times 2.0 = 1.12$	$0.7 \times 0.8 \times 1.0 = 0.56$
	<u>-4.05</u>	<u>-2.32</u>	<u>-1.16</u>
Adj. Net Benefits, $\bar{Z}$ .....	8.35	4.78	3.64

PART B

$(u - v_0) = 2.0, v = 0.7$

	Hydropower	Steam	Diesel
Net Benefits, $\bar{B}$ .....	12.4	7.1	4.8
$(u - v_0)k$ .....	$2.0 \times 5.0 = 10.0$	$2.0 \times 2.0 = 4.0$	$2.0 \times 1.0 = 2.0$
$vh$ .....	$0.7 \times 0.3 \times 5.0 = 1.05$	$0.7 \times 0.8 \times 2.0 = 1.12$	$0.7 \times 0.8 \times 1.0 = 0.56$
	<u>-11.05</u>	<u>-5.12</u>	<u>-2.56</u>
Adj. Net Benefits, $\bar{Z}$ .....	1.35	1.98	2.24

Source: Values of net benefits,  $\bar{B}$  are from Table I, Part C, Column (8), first 3 lines. Other terms are calculated according to equation 10 of the text using assumed values for  $(u - v_0)$  and  $v$  as indicated.

high values reflect, of course, the high benefits assumed for output, among other things. It seems fair, therefore, to characterize a value of  $u=0.7$  as representing a relatively ample budget in the early stages of economic development. Part B of table 2 assumes a value of  $u=2.1$ , which can be considered to represent a tight budget.

44. The other coefficients,  $v$  and  $v_0$ , are assumed the same in both parts of table 2. It is also assumed in both parts of table 2 that 80 percent of the value of plant and equipment is imported ( $h=0.8k$ ) for diesel and steam power, but only 30 percent is imported ( $h=0.3k$ ) for hydropower. The proportion imported can, of course, vary a good deal and hence also help to determine the relative merits of the different technologies. It will be noted that the uses of foreign exchange here considered include only plant and equipment. A more complicated problem arises when fuel importation is considered, as noted in case 4, Appendix D.

45. Now, consider the following situation. Suppose the total available budget for power plants is \$7.0 million, that the hydroelectric plant is considered for one site, and the diesel and steam plants are alternatives for another site. The requirement of compatibility prevents the construction of both diesel and steam plants, but does not prevent the construction of the hydroelectric plant and either of the other two.

46. According to the  $\bar{Z}$  values shown in table 2, which are calculated following equation 10, the hydroelectric and steam projects should be constructed with  $(u-vv_0)=0.6$ , while the hydroelectric and diesel projects should be undertaken with  $(u-vv_0)=2.0$ . The implications of the adjustment of net benefits accord-

ing to equation 10 are illustrated in table 3, where the total net benefits for each of the two alternative combinations of projects are shown for  $(u-vv_0)=0.6$  (Part A, table 3) and  $(u-vv_0)=2.0$  (Part B, table 3). The results confirm the preceding selection based on Table II. The highest total net benefits with  $(u-vv_0)=0.6$  are found in the hydroelectric and steam projects; with  $(u-vv_0)=2.0$ , the highest net benefits result from expenditure on the hydroelectric and diesel projects. The \$1 million that is freed by installing the diesel rather than the steam project is spent on backlog projects. The \$0.80 million of foreign exchange that is freed by the installation of the diesel rather than the steam project is likewise channeled into other uses, which in this example are represented by the  $v$  value of 0.7, resulting in a net benefit of \$0.56 million. It is clear that a variety of alternative considerations can influence the choice among the three technologies, involving different combinations of  $v$  as well as  $(u-vv_0)$  and different proportions of foreign exchange to total capital cost.

47. If the power-projects budget were limited to \$6 million, it would be necessary to choose between the steam project on the one hand and the hydroelectric plus diesel projects on the other hand. With either the Part A or Part B assumptions, the latter two would win out. A more difficult question is which project to choose if the budget is limited to \$5 million. According to table 2, the hydroelectric project should be selected if  $(u-vv_0)=0.6$ , and the diesel project if  $(u-vv_0)=2.0$ . Calculations analogous to those shown in table 3 will confirm the wisdom of these choices.

48. Finally, it is possible that the coal plant might come into more favorable standing as compared with the diesel

TABLE 3. Total net benefits with power-project budget of \$7.0 million

[Figures are in millions of dollars, except for  $(u-vv_0)$  and  $v$ ]

PART A		PART B	
$(u-vv_0)=0.6, v=0.7$		$(u-vv_0)=2.0, v=0.7$	
Hydropower	= 12.4	Hydropower	= 12.4
Steam	= 7.1	Steam	= 7.1
Backlog projects	$0.6 \times 1.0$	Backlog projects	$2.0 \times 1.0$
h adjustment	$0.7 \times 0.8 \times 1.0 = 0.56$	h adjustment	$0.7 \times 0.8 \times 1.0 = 0.56$
$\bar{B}$	19.5	$\bar{B}$	19.5
	-----		-----
	18.36		19.76

Source: Net benefits for hydroelectric, steam, and diesel are from Table I, Part C, column (8), first 3 lines. Backlog projects and h adjustments are calculated as indicated using corresponding values of  $(u-vv_0)$  and  $v$ .

plant even at values of  $(u - vv_0)$  in the range of those shown in Part B of table 2 if diesel fuel must be imported and coal can be obtained from domestic sources. (The opposite, of course, would be true if coal had to be imported and diesel fuel were available at home.) An approximation method of making the adjusted present value of net benefit calculations is described in Appendix D, Case 4 for the case where fuel must be imported.

#### Application of Criteria

49. A complete analysis of alternatives should consider the effects of different sized installations of the different technologies. Larger scale production installations and lower production costs may be offset by the costs of distributing power over wider market areas. Although the examples have been limited to production cost comparisons, a proper application of the criteria must include transmission and distribution as a part of project costs. It is reasonable to expect that in early stages of economic development, the choice will tend to favor smaller

projects because (a) there are few large high-density power markets and (b) transmission and distribution expenses are capital-intensive. Large power installations can be expected to become more numerous in later stages of economic development.

50. Application of the criteria may be complicated in some cases by complementarities between production and use of power. A hydroelectric project might be considered only in conjunction with the manufacture of primary aluminum, or a small diesel facility only in combination with a village refrigeration unit. Complementarities of power-production projects with particular power using projects suggest the need for combining the power budget with the appropriate manufacturing budgets, at least for an evaluation of the combined production-use projects. Fortunately, however, production-use complementarities are the exception rather than the rule for power projects (in contrast to the situation in many manufacturing industries). Accordingly, the complications that result from combining budgets can be avoided in most circumstances.

### APPENDIX A

#### Mathematical Equivalence of Annual Net Benefit and Sinking Fund Methods

51. The sinking fund method determines annual capital and interest costs as:

$$(A-1) \quad R + kr$$

Where  $R$  is defined so that

$$(A-2) \quad k = R[1 + (1+r) + (1+r)^2 + \dots + (1+r)^{n-1}]$$

Substituting for  $R$  in A-1 gives

$$(A-3) \quad \frac{k\{1+r[1+(1+r)+(1+r)^2+\dots+(1+r)^{n-1}]\}}{1+(1+r)+(1+r)^2+\dots+(1+r)^{n-1}}$$

Now, in general, for geometric progressions, the sum of a series

$$S_n = a + as + as^2 + \dots + as^{(n-1)}$$

$$(A-4) \quad = \frac{a(s^n - 1)}{s - 1}$$

Let  $a=1$  and  $s=(1+r)$ . Then

$$(A-5) \quad \sum_{t=0}^{n-1} (1+r)^t = \frac{(1+r)^n - 1}{r}$$

Substitute A-5 for the series in brackets in the *numerator* of expression A-3 to get:

$$(A-6) \quad \frac{k(1+r)^n}{1 + (1+r) + (1+r)^2 + \dots + (1+r)^{n-1}}$$

Dividing numerator and denominator of A-6 by  $(1+r)^n$ , it can be readily seen that the result is identical with the last term in equation 8 of the text.

## APPENDIX B

### Derivation of Social Time-Preference From Individual Time-Preferences

52. Where it is desired to derive a social rate of time-preference that depends on the independent time-preferences of individuals, the following logic may be appropriate.<sup>13</sup> Consider the case where  $\bar{B}=0$ , i.e., a project is just worthwhile in the sense that returns will cover all costs. Then

$$(B-1) \quad \bar{V} - \bar{D} = k$$

Each individual in society (denoted by the running subscript  $p$ ) is assumed to pay (through taxes) a fraction  $x_p$  of the investment cost  $k$  (in some cases  $x_p$  may be zero) and to receive a fraction  $b_p$  of the gain  $(\bar{V} - \bar{D})$ . Then, if there are  $m$  individuals in society,

$$(B-2) \quad \sum_{p=1}^m b_p (\bar{V} - \bar{D}) = \sum_{p=1}^m x_p k = k$$

Now, it can be shown that

$$(B-3) \quad \sum_{t=1}^{\infty} \frac{1}{(1+r)^t} = \frac{1}{r}$$

If the annual gain  $(\bar{V} - \bar{D})$  continues long enough to approximate a perpetuity,  $b_p(\bar{V} - \bar{D})$  can be replaced by  $b_p(V - D)/r_p$ . The term  $r_p$  represents the time-preference of individual  $p$ . Making the replacement and rearranging terms,

$$(B-4) \quad V - D = k \frac{1}{\sum_{p=1}^m \frac{b_p}{r_p}}$$

Thus, the rate by which investment  $k$  is multiplied in perpetuity to get an equivalent stream of value  $(V - D)$  is the weighted harmonic mean of individual rates.

53. The result of the analysis is not changed by assuming shorter lives, but the presentation is unnecessarily complicated. It is not appropriate to consider nonzero values of  $B$  because the object is only to find a rate of return that measures social

time-preference a cost of investment  $k$ ). If positive values of  $B$  were used, higher rates of return would be found. These could not be interpreted as costs, but as internal rates of return characterizing the particular value of  $B$  chosen.<sup>14</sup>

54. The most important limitation of the analysis is an economic one. It will be recalled that either  $x_p$  or  $b_p$  may be zero in particular cases. This means that some individuals who pay taxes may have no gains and some individuals who do not pay taxes may have gains. Equation B-4 implies that a dollar of annual income for one individual is as good as a dollar of income for another. If projects cannot be considered on this basis, then neither can equation B-4 be used.

### APPENDIX C

#### Mathematical Equivalence of Ranking by Annual Flows and Infinite Series

55. Consider two projects,  $a$  and  $c$ , the net benefits of which are to be compared. Project  $a$  has an expected life of  $n$  years; project  $c$ , an expected life of  $m$  years. Equation 8 of the text can be written as follows for project  $a$ :<sup>15</sup>

$$(C-1) \quad B_a = V_a - D_a - k_a \left( \frac{r(1+r)^n}{(1+r)^{n-1}} \right)$$

The present value of net benefits from infinite replacement of the same project is

$$(C-2) \quad \bar{B}_a = \frac{V_a}{r} - \frac{D_a}{r} - k_a \frac{(1+r)^n}{(1+r)^{n-1}}$$

The first two terms on the right hand side of equation C-2 follow from equation B-3. The last term is derived by taking the summation

$$(C-3) \quad k \left( 1 + \frac{1}{(1+r)^n} + \frac{1}{(1+r)^{2n}} + \dots \right) = k \sum_{t=0}^{\infty} \left( \frac{1}{(1+r)^n} \right)^t$$

in accordance with equation A-4 with  $a=1$  and  $s=1/(1+r)^n$ . By proper clearing of equation C-1 and C-2, it can be shown that:

$$(C-4) \quad \frac{B_a}{B_c} = \frac{\bar{B}_a}{\bar{B}_c} = \frac{(V_a - D_a)[(1+r)^n - 1] - rk_a(1+r)^n \left( \frac{(1+r)^n - 1}{(1+r)^n} \right)}{(V_c - D_c)[(1+r)^m - 1] - rk_c(1+r)^m \left( \frac{(1+r)^m - 1}{(1+r)^m} \right)}$$

### APPENDIX D

#### The Problem of Choice

56. The following is a mathematical derivation of equation 10 of the text and similar cases for evaluation of investments. The derivation is an adaption of a method developed by Steiner.<sup>16</sup> The major difference from Steiner's analysis is that interest herein centers on the problem of choice as it is likely to be seen in less developed countries. Emphasis is given to limitations on budgetary funds and foreign exchange. Steiner's orientation, in contrast, is toward project planning in the United States, with emphasis on possible preemption by government of projects that would otherwise be undertaken privately and on the financing of projects by

special assessments, as well as the budgetary restriction. The analysis herein will not consider preemption in the same sense, but will deal with transfer of foreign exchange from private to public projects. Nor will the following analysis consider financing of projects from special assessments. For the purpose of project planning described herein, the public budget made available for power projects is assumed to be fixed.

57. The method considers each project,  $i$ , in relation to a specific service,  $j$ , that it is able to provide. The projects are discrete units. If more than one size of a given power facility is to be considered, each size is treated as a different project. If two facilities are complementary, they are considered together as a single project.

58. Four cases are treated: 1—public planning in an economy with an important private-business sector, 2—public planning in the absence of an important business sector, 3—private project planning, and 4—the special problem of projects that use imported fuel as well as imported capital equipment. The first three cases consider projects that use foreign exchange only for capital equipment.

59. The object of decision-makers in all cases is to maximize the present value of net benefits in all sectors to the extent of their control, subject to indicated constraints. Thus, in case 1, public decision-makers are assumed to maximize economy-wide benefits in their choice of public projects that will drain foreign exchange away from private projects. That is, foreign exchange is assumed to be preempted from private use only where the public use will result in more economy-wide net benefits.

60. The budgetary constraint is assumed only to restrict expenditures of capital,  $k$ . It is assumed that operating expenses are financed from revenues currently collected as the project is operated. If revenues are not to be collected, but a project is to operate out of tax revenues for distribution of services without charge or at a price less than annual equivalent total costs, than the following analysis can still be used by separating the investment budget from the operating budget and making a separate analysis to determine the probable future adequacy of the latter before the project is considered for evaluation in the investment budget, which is the principal object of analysis here.

61. A different situation applies for foreign exchange. The foreign-exchange component of investment is but one part of all uses of foreign exchange in the economy. Other uses include imports for current consumption. Therefore the foreign exchange constraint permits other than investment uses of funds (see definition of  $h$ , below).

#### NOTATION

$\bar{A}$  = present value of net benefits of private projects if deprived of foreign exchange, dollars or other monetary units.

$\bar{B}$  = present value of net benefits, dollars or other monetary units.

$G$  = imported fuel consumed per year in dollars or other monetary units of foreign exchange evaluated at official foreign exchange rates.

$H$  = total available foreign exchange in dollars or other monetary units evaluated at official exchange rates.

$K$ =total available budget or subbudget in dollars or other monetary units.  
 $\bar{M}$ =present value of net benefits from domestic capital expenditures, dollars or other monetary units.  
 $\bar{N}$ =present value of net benefits from foreign exchange, dollars or other monetary units.  
 $\bar{T}$ =present value of total net benefits for all sectors of the economy.  
 $X$ =level of conduct of project =0,1 (discreteness).  
 $g$ =dollars or other monetary units of the budget or subbudget spent on domestic capital equipment.  
 $b$ =dollars or other monetary units spent on foreign exchange. Foreign exchange is used only for capital equipment in sector 1 ( $b_{ij}$ ), but may be used for any purpose in sectors 2 or 3 ( $b_p$  and  $b_q$ , respectively).  
 $i$ =subscript to identify projects, sector 1.  
 $j$ =subscript to identify services, sector 1.  
 $k$ =capital cost in dollars or other monetary units.  
 $p$ =running subscript for sector 2 project-service combinations.  
 $q$ =running subscript for sector 3 project-service combinations.  
 $t$ =running subscript to denote time in years.  
 $u$ =present value of net benefit per dollar or other monetary unit of funds in sector 3.  
 $v$ =present value of net benefit forgone in sector 2 per dollar or other monetary unit of foreign exchange used in public projects.  
 $v_o$ =foreign exchange (measured in dollars or other monetary unit at official exchange rates) required per dollar or other monetary unit of sector 3 projects.  
 $w$ =present value of net benefit per dollar or other monetary unit of domestic capital expenditure.  
 $z$ =present value of net benefit per dollar or other monetary unit of foreign capital expenditure.

### Case 1: Public Planning With a Private Sector

62. The economy is divided into three parts, or sectors. Sector 1 consists of all public projects considered for support from a given subbudget. Sector 2 consists of all private projects that might use foreign exchange. Sector 3 consists of the list of inchoate undifferentiated public projects on which expenditures would be made if the choice were extended beyond sector 1. The purpose of including sector 3 is to assure that any project included from sector 1 in the final list of projects that are adopted will have a higher net benefit than any project not specifically included and also to recognize that additional funds have productive value. Sector 3 also serves the purpose of absorbing any funds remaining after an optimum combination of sector 1 projects has been chosen. Such funds might remain as a result of the indivisibilities of the discrete projects that constitute an optimum for sector 1.

63. The object is to maximize

$$(D-1) \quad \bar{T} = \sum_{31} X_{ij} \bar{B}_{ij} + \sum_{32} X_p \bar{B}_p + \sum_{33} X_q \bar{B}_q$$

subject to

$$(D-2) \quad \sum_{s1} X_{ij}k_{ij} \leq K \quad \text{budget constraint)}$$

$$(D-3) \quad \sum_{s1} X_{ij}h_{ij} \leq H \quad \text{(foreign exchange constraint)}$$

$$(D-4) \quad h_{ij} \leq k_{ij} \quad \text{(foreign exchange used for capital only in sector 1)}$$

$$(D-5) \quad X_{ij} = 0, 1, \text{ all } ij \quad \text{(discreteness)}$$

$$(D-6) \quad \sum_j X_{ij} = 1 \quad \text{(incompatibility of } j\text{'s)}$$

$$(D-7) \quad \sum_i X_{ij} = 1 \quad \text{(incompatibility of } i\text{'s)}$$

By definition

$$(D-8) \quad \sum_{s1} X_{ij}k_{ij} + \sum_{s3} X_qk_q = K$$

$$(D-9) \quad \sum_{s1} X_{ij}h_{ij} + \sum_{s2} X_ph_p + \sum_{s3} X_qh_q = H$$

$$(D-10) \quad \bar{B}_q = uk_q$$

$$(D-11) \quad \sum_{s2} X_p\bar{B}_p = v \sum_{s2} X_ph_p + \sum_{s2} X_p\bar{A}_p$$

$$(D-12) \quad \sum_{s3} X_qh_q = v_o \sum_{s3} X_pk_p$$

Thus:

$$\begin{aligned} \sum_{s3} X_q\bar{B}_q &= u \sum_{s3} X_qk_q \\ &= u(K - \sum_{s1} X_{ij}k_{ij}) \end{aligned}$$

$$\begin{aligned} \sum_{s2} X_p\bar{B}_p &= v(H - \sum_{s1} X_{ij}h_{ij} - v_o \sum_{s3} X_qk_q) + \sum_{s2} X_p\bar{A}_p \\ &= v(H - \sum_{s1} X_{ij}h_{ij} - v_o \sum_{s3} X_qk_q) + \sum_{s2} X_p\bar{A}_p \\ &= v[H - \sum_{s1} X_{ij}h_{ij} - v_o(K - \sum_{s1} X_{ij}k_{ij})] + \sum_{s2} X_p\bar{A}_p \end{aligned}$$

Substituting for  $\sum_{s2} X_p\bar{B}_p$  and  $\sum_{s3} X_q\bar{B}_q$  in equation D-1:

$$(D-13) \quad \bar{T} = \sum_{s1} X_{ij}[\bar{B}_{ij} - (u - vv_o)k_{ij} - vh_{ij}] \\ + (u - vv_o)K + vH + \sum_{s2} X_p\bar{A}_p$$

64. The last three terms in equation D-13 are constants and hence do not affect the values of the variables that maximize  $\bar{T}$ . These three terms may therefore be omitted from the objective function insofar as the determination of optimal values of the variables is concerned. The term  $(u - vv_o)K$  is the value of the subbudget at the rate of net benefit per monetary unit in sector 3 less the transfer of foreign exchange into sector 3 at the rate  $vv_o$ . The term  $vH$  is the value of total foreign exchange if used entirely in the private sector, i.e., valued at the rate of present value of net benefit per dollar of the foreign exchange preempted by the public projects. The last term in equation D-13 is the base value of private projects below which the

present value of net benefits will not sink if they are completely deprived of foreign exchange, as indicated by definition D-11. It is clear that the last two terms in equation D-13 represent the total present value of net benefits in the case where there is no public use of foreign exchange.

### Case 2: Public Planning without a Private Sector

65. The economy is divided into two sectors rather than three. This is accomplished simply by omitting sector 2 and otherwise using sectors 1 and 3 as defined for case 1 above.

$$(D-14) \quad \text{Maximize } \bar{T} = \sum_{s1} X_{ij} \bar{B}_{ij} + \sum_{s3} X_q \bar{B}_q$$

subject to constraints D-2, D-3, D-4, D-5, D-6, and D-7. If definitions D-8 and D-10 are applied, the result is

$$\sum_{s3} X_q \bar{B}_q = u \sum_{s3} X_q k_q = u \left( K - \sum_{s1} X_{ij} k_{ij} \right)$$

Substituting in equation D-13:

$$(D-15) \quad \bar{T} = \sum_{s1} X_{ij} \left( \bar{B}_{ij} - u \sum_{s1} X_{ij} k_{ij} \right) + uK$$

66. Equation D-16 would be redundant (or conflicting) with the above assumptions. A more flexible and more useful formulation of case 2 would substitute the following definitions:

$$(D-8) \quad \sum_{s1} X_{ij} k_{ij} + \sum_{s3} X_q k_q = K$$

$$(D-16) \quad \sum_{s1} X_{ij} b_{ij} + \sum_{s3} X_q b_q = H$$

$$(D-17) \quad \bar{B}_q = \bar{M}_q + \bar{N}_q$$

$$(D-18) \quad \bar{M}_q = w g_q$$

$$(D-19) \quad \bar{N}_q = z b_q$$

$$(D-20) \quad k_q = g_q + b_q$$

Then, subtracting D-16 from D-8 and using the above definitions:

$$\sum_{s1} X_{ij} (k_{ij} - b_{ij}) + \sum_{s3} X_q g_q = K - H$$

$$\sum_{s3} X_q g_q = K - H - \sum_{s1} X_{ij} (k_{ij} - b_{ij})$$

$$\sum_{s3} X_q b_q = H - \sum_{s1} X_{ij} b_{ij}$$

$$\sum_{s3} X_q \bar{B}_q = \sum_{s3} X_q (w g_q + z b_q) = w \sum_{s3} X_q g_q + z \sum_{s3} X_q b_q$$

$$= \sum_{s1} X_{ij} [-w k_{ij} - (z - w) b_{ij}] + w + (z - w) H$$

Substituting in equation D-13

$$(D-21) \quad \bar{T} = \sum_{s1} X_{ij} [B_{ij} - w k_{ij} - (z - w) b_{ij}] + wK + (z - w)H$$

67. The definitions lying behind equation D-21 are less restrictive than those behind equation D-15, in that there are no fixed proportions of total expenditures to foreign exchange assumed in sector 3. Otherwise D-21 is expressed

in terms analogous to those of D-13 (case 1) with analogous economic interpretations.

### Case 3: Private Planning

68. Decision makers are not in a position to control the use of funds for investment or foreign exchange outside the activities of their private firms. In this case, sector 1 represents the collection of projects considered for investment from a private budget of size  $K$ . Sector 3 represents the backlog of undifferentiated projects that the firm would consider if a much larger budget were available. Foreign exchange is rationed by the government, as always. The mathematics of case 3 is exactly the same as case 2 with the exception that the constraint D-3 is not applicable. Foreign exchange is available project-by-project according to government policy so as to result in economy-wide most efficient use of foreign exchange. In other words, public planners have taken account of foreign-exchange allocations to private businesses in their simultaneous solution of case 1. The values of  $h_{ij}$  and  $h_q$  used by private decision-makers in equation D-21 (reinterpreted for private planning as above) are then specified by government.

### Case 4: Projects Using Imported Fuel

69. Case 4 will be treated as an amended version of case 1. The necessary amendments to evaluate projects using imported fuel in cases 2 and 3 will be clear by analogy.

70. Consider first the cost of importing fuel during the same year in which the capital expenditure  $k$  is made and let only one project,  $i=a, j=b$ , use imported fuel. The analysis is then the same as before, except that wherever  $h_{ij}$  appears, the expression  $(h_{ij} + G_{ab})$  is substituted. ( $ab$  is included in  $ij$ ). Thus, the final objective function D-13 in case 1 is modified to read:

$$(D-22) \quad \bar{T} = \sum_{s1} X_{ij} [\bar{B}_{ij} - (u - vv_0)k_{ij} - v(h_{ij} - G_{ab})] \\ + (u - vv_0)K + vH + \sum_{s2} X_p \bar{A}_p$$

71. Equation D-22 takes account of only the fuel imported during the first year of plant operation. A complete analysis requires that the foreign-exchange constraint be taken into account in all years in which the plant is operated. In accordance with the approach used herein,  $k_{ij}$  and  $h_{ij}$  are equal to zero after the first year. Future operating costs and benefits have been taken into account by using the present value of net benefits. It remains to take into account the future effects of  $G_{ab}$  on foreign exchange. For this purpose, it is necessary to consider a set of equations for each year project  $ab$  is in operation. The objective function for the first year is D-22. It is exactly the same for all succeeding years except  $ab$  is not included in  $ij$ . The constraints are as shown in D-2 through D-7 except that D-3 is replaced by

$$(D-23) \quad \sum_{s1} X_{ij}(h_{ij} + G_{ab}) + \sum_{s3} X_q h_q \leq H$$

the first year and by

$$(D-24) \quad \sum_{s1} X_{ij} h_{ij} + G_{ab} + \sum_{s3} X_q h_q \leq H$$

in succeeding years. As before,  $ij$  includes  $ab$  the first year, but not in succeeding years. If the entire set of projects (including project  $ab$ ) over all years of life of project  $ab$  has a higher present value with  $ab$  than without  $ab$ , then project  $ab$  is included.

72. The above-described test is probably impractical for operating decisions, especially when it is remembered that there may be many projects like  $ab$  that consume imported fuel. Therefore, as a practical alternative, it is suggested that equation D-22 (as simplified by omission of constant terms for the purpose of selecting net benefit maximizing projects) be used unless there is reason to think that foreign exchange will be much harder to get in future years over the life of the fuel-importing project. This suggestion treats conditions in the current year as representative of (or perhaps not quite as good as) conditions likely to obtain in succeeding years. More specifically, it assumes that future investment opportunities will offer no more net benefits on the whole, that at least as much foreign exchange will be available, and that at least as large budgets will be available. In other words, it is based on the view that the economic conditions favoring fuel importation now will not be reversed in the future. If there is good reason to expect these conditions to be reversed, approximations, at least, of the longer calculation had best be made.

#### FOOTNOTES

<sup>1</sup> Galenson, W., H. Leibenstein, "Investment Criteria, Productivity, and Economic Development," *Quarterly Journal of Economics*, 69 (August, 1955) suggest another criterion: the choice of investment projects in such a way as to yield maximum returns for reinvestment. In the limited scope of their assumptions, this amounts to ignoring the value of contemporary output as capital is accumulated for the sake of maximizing output at some future time. Eckstein, O., "Investment Criteria for Economic Development and the Theory of Intertemporal Welfare Economics," *Quarterly Journal of Economics*, 71 (February 1957) makes a thorough analysis of the Galenson-Leibenstein propositions from the standpoint of maximization of a continuous stream of output but recognizing their fundamental point that the selection of a set of projects implies a specific income distribution which in turn affects the rate of saving. His conclusion is that "\* \* \* even in (the case where government cannot achieve a satisfactory level of investment by fiscal means) the investment criterion must reflect both the efficiency (current-output productivity) and the capital accumulation of projects, and \* \* \* the latter will become dominant only if the actual level of investment falls far short of the desired level." (p. 85) For purposes of the present analysis, the Galenson-Leibenstein argument will be ignored, partly because Eckstein shows it to be limited to the case where sufficient revenues cannot be acquired by fiscal means and partly because income distribution can be shifted in the direction desired by Galenson and Leibenstein by direct application of regressive taxes if desired. See Higgins, B., *Economic Development* (New York, 1959), p. 459 discussion of unequal distribution of income during industrialization of England.

<sup>2</sup> The exact sense in which  $k'$  is an annual equivalent is indicated in paragraph 20.

<sup>3</sup> For the underlying logic of this treatment of taxes, see Ruggles, R., N. D. Ruggles, *National Income Accounts and Income Analysis*, (McGraw-Hill, 1956), or other standard works on social accounting.

<sup>4</sup> See Appendix A.

<sup>5</sup> Straight-line depreciation consists of making the charge  $k/n$  to depreciation each year. Interest is also explicitly included, giving the result:

$$B = V - D - k \left( \frac{1 + rn}{n} \right) \quad (i)$$

The numerical difference between total annual equivalent costs calculated by equation (i) and equation 8 of the text depends on three considerations: the value of  $r$ , the value of  $n$ , and the relative values of  $D$  and  $k$ . It can be shown that annual equivalent costs are overstated in straight-line depreciation calculations by about 1 percent in the case where  $n=10$  years,  $r=4$  percent, and the  $D/k$  ratio is 90/10 (with  $D$  calculated at 0 interest rate), and by about 20 percent in the case where  $n=50$ ,  $r=8$  percent and  $D/k$  is 50/50 (with  $D$  calculated at 0 interest rate). Large hydroelectric projects come close to the latter case, small diesel projects, to the former. It is clear that cost comparisons among a variety of power technologies can be in error by a significant margin when made using the method of straight-line depreciation.

<sup>6</sup> The restricted function of the rate of interest where public budgets for investment are determined autonomously is analyzed by Eckstein, O., *Investment criteria for economic development and the theory of intertemporal welfare economics*, *Quarterly Journal of Economics*, 71 (February, 1957).

<sup>7</sup> It may be argued that the example is unfair to steam and hydroelectric power generation on the grounds that both have lower per kilowatt-hour costs in larger sized installations. In an empirical study it would be appropriate to consider all sizes of power plants and map out the circumstances in which each is best. This, however, is not possible within the limits of the present analysis and is also not relevant for present purposes.

<sup>8</sup> This is, in fact, the approach used by Alchian, A. A., *Economic Replacement Policy*, Rand Corporation Report-224 (Santa Monica, California, 1952).

<sup>9</sup> There is another context in which foreign exchange effects need not be considered for the planning of power projects. This is in the importing and exporting of power itself. Very little power moves in international trade and this is largely in the form of electricity across the borders of adjacent countries. Therefore, no account need be taken of foreign power costs or of potential competition by foreign suppliers in the domestic market. In this respect, the planning of power investments is different from that of most investments in manufacturing, agriculture, and extractive industries.

<sup>10</sup> Steiner, P. O., *Choosing among alternative public investments*, *American Economic Review*, 49 (December, 1959).

<sup>11</sup> Official exchange rates are used because these are the rates at which payment is made for imports. Professor Rosenstein-Rodan has shown that the value of foreign exchange is typically greater than the value of domestic currency to a less developed country. Moreover, the ratio of the value of domestic currency tends to become greater the lower the per capita gross national product of the country. See his "International Aid for Underdeveloped Countries," *Review of Economics and Statistics*, 43 (May, 1961). The increased value from the use of foreign exchange appears in the gross benefits  $V_{ij}$  and hence in the  $B_{ij}$ .

<sup>12</sup> Implicitly, each project is compared with alternative amounts of foreign exchange,  $h$ , subject to restraint D-3 of Appendix D. Each project with different amounts of  $h$  is a separate project with separate  $\bar{B}$ .

<sup>13</sup> From an unpublished work by Robert Dorfman, Department of Economics, Harvard University.

<sup>14</sup> Internal rates of return are sometimes used in place of present values to rank projects. In the present case internal rates of return will yield the same ranking of projects as present values, but this is not true in all cases. See Solomon, E., *The arithmetic of capital budgeting decisions*, *Journal of Business*, (April, 1956).

<sup>15</sup> See source for table I, text.

<sup>16</sup> See footnote 10.

---

# Energy Cost Comparisons

## Theoretical and Practical Problems in Comparing Nuclear and Conventional Energy Costs, with Particular Reference to Less Developed Areas

PERRY D. TEITELBAUM

*Research Associate, Resources for the Future, Inc., Washington, D.C.*

1. A number of assumptions are commonly encountered in making cost estimates of electric power plants. These assumptions may significantly affect the conclusions of a cost comparison and therefore a decision regarding the investment of millions of dollars. It is the purpose of this paper to examine the validity of these assumptions, particularly as they refer to conditions of electric power supply and demand in the less industrialized countries, where capital scarcity and lack of foreign exchange make the problem of optimal allocation of limited means particularly urgent.

2. The paper is divided into two parts. In the first we present a summary review of some of the basic accounting factors involved in calculating electric power generating costs. This review provides background for the analysis, in the second part of the paper, of the validity of these costing assumptions in the case of a comparison involving nuclear and conventional power plants, and of the extent to which these assumptions must be modified in undertaking nuclear-conventional cost comparisons under conditions likely to prevail in the less developed areas.

### **Factors in Estimating Electricity-Generating Costs**

3. Electricity generating costs are usually expressed per unit of output; in the United States the figure is given in mills (tenths of a cent) per kwh. In order to arrive at a single parameter that is uniquely descriptive of the complex of equipment and operations characterizing a particular plant, it is necessary to specify numerical values for certain major cost-determining factors.

4. One of these key elements is the capital investment cost of the plant. This cost can be expressed in dollars per kw of capacity. In the case of most hydroelectric plants, however, this figure can be misleading since it fails to characterize the seasonal nature of the capacity which is based on rainfall and available storage facilities. It is therefore necessary in the case of hydro-power to distinguish between "dependable" or "firm" power, which is the continuous output of capacity available throughout every year (except possibly the driest years on record) and "secondary" power, which is power available intermittently or for only portions of the year because of the afore-

mentioned inadequacy of water-storage capacity or because of limitations on power generation due to considerations of downstream water storage, irrigation, etc. In contrast, this distinction is unnecessary in the case of thermal, i.e., fossil-fuel and nuclear, power plants, which are theoretically available for full service at all times of the year.

5. There are many detailed problems involved in allocating costs of multipurpose hydroprojects to power generation as well as technical and accounting problems in classifying capital expenditures in connection with power-generating plants generally, but these problems need not detain us here. Nor need we be concerned with the formidable task of estimating capital costs and performance parameters of future nuclear or thermal plants—which forms a vital part of any cost comparison between the two—since this is more of a technological engineering problem. Instead, we will proceed with the convenient assumption that the capital costs of the various alternative types of power generating plants have been correctly estimated, and we will concern ourselves with the subsequent problem of what to do with these estimates.<sup>1</sup>

6. Conversion of a capital cost per kw figure into the fixed-cost component of generating cost per kwh requires explicit introduction of two additional factors. One of these is the plant factor, which can be defined as the ratio of net electrical generation to the total that would have been generated if the plant had operated continuously at rated capacity. The plant factor represents the degree of utilization of the electric power plant, and because of the desirability of spreading fixed costs over the largest possible output, the higher the plant factor, the lower the total generating cost. The second factor

required to convert capital cost into a component of generating cost is the rate of annual fixed charges. This will be discussed following the discussion of plant factor.

7. The plant factor of individual stations depends on various technical and economic factors, and can be expressed in terms of any given period of time. So far as an individual plant is concerned, two factors limiting its availability for service are the necessity to effect repairs and to carry out normal maintenance operations. Where these can be postponed, they can be fitted into the overall pattern of system maintenance activities normally carried out at times when demand is sufficiently slack to permit the system to meet its load without the particular unit in question. But in order to carry out emergency repairs on a plant, it may be necessary to fall back on the system reserve, which is often specified as either equal to the largest single plant in the system or to a percentage, such as 10 percent or 15 percent, of maximum load, whichever is greater.

8. A concept similar to plant factor when discussing system demand is the system-load factor defined as the ratio of average load to peak load. This is determined by the demand characteristics of its customers. Whereas many industrial consumers have a relatively constant demand pattern, which may even be on an around-the-clock basis, the electricity demand of residential and commercial customers varies more sharply, depending on weather, lighting conditions, and on commercial practices. Generally speaking, the greater the proportion of industrial customers in a system, the higher its load factor.

9. Subject to certain technical limitations regarding the ability of individual

plants to "follow" excessive load variations and to such considerations as the need to make emergency repairs, the electric utility system is free at any given time to select the most economic pattern of plant loading. This means, in practice, that the economically most efficient plants, i.e., those with the lowest running costs, will be used most intensively, and that other plants will be assigned to meet other parts of the system load depending on their running costs. The higher the running costs, the lower the plant factor.<sup>2</sup>

10. In mixed hydro-thermal systems, hydro-plants are normally assigned to base load duty at times when water is available, since the running costs of hydro-plants are virtually zero. However, the need to store water for peaking requirements in dry seasons (in the case of hydro-plants with limited storage capacity) and various limitations on hydro-generation in multipurpose projects, may prevent a hydro-plant from being assigned to base load duty at certain times of the year. Thus, the annual plant factors of hydro-plants may be well below those of thermal units even though their running costs are much lower.

11. Although it is normal in most industrial activities to engage in a certain amount of forward planning in connection with investment in new capacity, the necessity to do this is particularly great in the electric supply industry. This is due in part to the extremely rapid rate at which electric power consumption has grown throughout the world in countries at all stages of economic development, the expectation that this growth rate will continue, and the conviction that an adequate supply of electricity at reasonable cost is an indispensable element in economic growth and well-being. It is also due to the large amounts of capital

that are necessary (electric power generation, transmission, and distribution are extremely capital intensive), as well as the relatively long period of time required for planning, financing, and constructing power plants (as much as 5 years for thermal plants and more for hydro-plants). The expectation that electric power demand will grow at a rapid pace removes an uncertainty in forward planning which may exist in other economic activities, and it permits reasonable forecasts of expected lifetime plant factors in connection with cost calculations for particular power plants.

12. In most electrical supply systems where demand is growing relatively rapidly, it is the normal experience that new thermal plants are assigned to base load duty during the early years of their lives. The subsequent addition of newer and presumably more efficient plants to meet continuing load growth tends to displace the original plant in the system loading pattern, so that it ultimately moves out of the base-load portion and operates at lower plant factors. Eventually, due to increases in its maintenance and repair costs and its higher fuel costs per unit of output in contrast to all the newer plants in the system, it reaches the category of semiretirement, being called upon only a few hours of the year at the time of peak demand.<sup>8</sup>

13. The operating experience of thermal power plants in the United States and Western Europe has in the recent past yielded lifetime plant factors on the order of 50 percent. It should be emphasized that these averages result largely from the normal economic pressures exerted on the system during the life of the plant to achieve the lowest system generating costs by assigning load to plants at all time on the basis of their relative

running costs. As suggested earlier, however, the introduction of hydro-plants into electric supply systems may upset this conclusion, since the hydro-plants would normally be assigned to base load whenever there was sufficient water. Thus, in a mixed hydro-thermal system, thermal plants might during their lifetime remain in the base load part of the loading diagram for a shorter period than if there were no hydro capacity in the system. In all cases, however, it must be recognized that the particular circumstances of each system, including its rate of growth, its proportion of base load demand, the availability of its hydro capacity, etc., can significantly alter the final results.

14. As will be demonstrated below, introduction of a nuclear power plant into an all-thermal system might, in a fashion similar to that described above for a hydro-plant, tend to upset the usual assumptions that are made regarding lifetime plant factors. And, to the extent that this effect can be foreseen, it would appear proper to take account of it in making cost comparisons between nuclear and conventional thermal power plants.

15. The rate of fixed charges on capital cost is the second element that must be introduced into a cost computation in order to translate capital cost into a component of generating cost. This rate includes several elements, all of which are considered fixed, in the sense that they are incurred once the plant has been built and also that they are independent of the scale of operation of the plant. One of these elements is provision for repayment of the capital required for the plant over its lifetime: this includes the payments of interest and repayments of principal on borrowed capital, and reasonable earnings (i.e., profits) on the

equity capital.<sup>4</sup> The fixed cost component should also include an allowance for the general costs of government services. These can be conveniently assumed to be equal to the taxes on the plant, which are assessed on the total capital cost, although certain questions arise, in comparing two different plants with substantially different capital costs, whether this method yields a fair comparison of the costs of such services in the two cases. Fixed costs may also include plant insurance.

16. A key consideration in selecting a suitable schedule of amortization payments is the choice of the proper period over which the payments are to be made. In order that the costs of the plant may be met in full during its period of service, the amortization period should equal the expected useful life of the plant.<sup>5</sup>

17. The useful life of a plant—more properly, the weighted average of the useful lives of the various components of the plant—depends on two interrelated factors: physical and economic obsolescence. Physical obsolescence can be defined as the (gradual increase in the) rate at which the plant wears out physically,<sup>6</sup> and economic obsolescence can be defined as the rate of increase of the cost of necessary maintenance and repair in comparison to the costs of retiring the plant and replacing it with new capacity. At some point in time, obviously, the balance of these costs, plus the plant's fuel costs which are also part of its running costs, would change and it would then become economic to retire the old plant. But, since some of the costs involved in making this decision cannot be foretold, it is impossible to decide beforehand what expected lifetime to assume for a plant. As will be explained further below, this

difficulty may even be compounded in the case of a nuclear plant.

18. The complement of fixed costs in total generating costs is running costs, consisting of operating and maintenance costs and fuel costs. These are defined to vary almost in direct proportion to plant output and they are essentially zero when the plant is in stand-by condition.<sup>7</sup> As suggested above, running costs in hydro-plants are negligible, while they may form the major part of generating costs in steam plants.

19. It is reasonable to expect that in nuclear plants that are considered to be competitive with conventional thermal plants, there will be a different proportionate breakdown of fixed and running costs. Fixed costs in a nuclear plant will undoubtedly exceed those in a conventional plant by virtue of the greater capital costs of the former. But, if the nuclear plant is to be competitive, its running costs will have to be compensatingly lower than those of a conventional plant. Indeed, it is this lowering of fuel costs, constituting the bulk of a plant's running costs, that is presumed to be the great advantage of nuclear over conventional power. Thus, a nuclear power plant will find itself in an intermediate position between hydro plants on the one hand, and fossil-fuel plants on the other so far as running costs are concerned and without the disadvantage of hydro that its availability is limited in certain seasons. As suggested, however, comparison of running costs provides the basis in a system for assigning plants to particular parts of the load, hence the load assignments which nuclear plants will experience in their lifetime may differ substantially from those of conventional thermal plants considered as alternatives. This difference introduces complications in the

matter of making cost comparisons between the two, which will be discussed below. Furthermore, the substantially lower running costs of a nuclear plant as compared to a conventional plant may be important in deciding the point at which the nuclear plant should be retired, since this will depend in the case of the nuclear plant on the length of time it will take until the relative rise in its running costs makes it economic to retire the plant and replace it with a new one.

#### **Validity of Standard Costing Procedures and Assumptions in Nuclear-Conventional Cost Comparisons With Particular Reference to Less Developed Areas**

20. In this section of the paper we will examine the validity of some of the basic procedures and assumptions usually encountered in cost comparisons between nuclear and conventional power plants. This examination will, it is hoped, suggest instances where alternative procedures may be more appropriate, as well as indicate which alternative procedures to select.

21. *Validity of plant-to-plant cost comparisons.* The simplest procedure for comparing the costs of two thermal power plants, one nuclear and the other fossil-fueled, is a direct comparison of their generating costs; the one with the lower cost under common, standardized assumptions regarding the rate of fixed charges on capital, annual plant factor, etc., being the preferred alternative. And, in point of fact, such comparisons are quite common. In following this procedure, however, it is necessary to appreciate just what is really being compared and just what the comparison yields.

22. It should be clear that a thermal power plant, as any other piece of capital equipment, is valued not for itself, but for the services it will perform. Obviously, where two alternatives can be expected to yield the identical stream of services, comparison of their generating costs is all that is necessary in making a choice between them.<sup>8</sup> But where the services of the two alternatives are substantially different, a simple comparison of costs alone may yield imperfect and only partial grounds for determining which is preferable on some objective basis.

23. Let us therefore consider how and why nuclear and conventional power plants are different. As regards costs, and ignoring purely technical differences, a nuclear plant involves substantially greater capital outlays than does a conventional plant of equal capacity—from one-and-one-half to perhaps twice as much or more for plants in the 100–200 mw size range.<sup>9</sup> In addition, the construction period of a nuclear plant is longer than that of a conventional plant, its fuel inventory (involving considerable fixed capital charges) is many times greater, and its running costs, i.e., fuel and operation and maintenance, may be substantially lower. A nuclear plant is unique in another important way: its fuel performance parameters are not fixed for life when the plant is built; future improvements in fuel technology and management can result in substantial increases in burn-up rates (and therefore lowered running costs), while such improvements are not possible in a conventional boiler. It is also assumed—but this will not be known with any degree of assurance for many years to come—that the useful life of a nuclear plant will not be as long as that of a conventional plant, although, as has been suggested earlier, this assumption

rests mainly on technical considerations regarding the expected ability of reactor components to withstand the harmful effects of radiation, and it ignores the question of economic obsolescence, i.e., whether it may be more economic in the future to engage in even extensive and costly repairs of damaged components in an older nuclear plant than to replace it with a new one. Such repairs would tend to increase the useful life of a nuclear plant beyond the limits that have hitherto been assumed and, in any case, considering some of the differences cited above, there is no *a priori* reason why the effects of economic obsolescence should yield similar useful lifetimes for both nuclear and conventional thermal plants.

24. The foregoing elements, and others, which are highly relevant in determining generating costs in each alternative plant, can only be rendered comparable if a present worth computation of all such costs is made: the use of an appropriate rate of interest permits one to combine present and future expenditures into a single figure. It is thus possible in a relatively simple fashion to calculate the present worth of all expenditures for each alternative, and these can be compared if, as suggested, the stream of services that each will yield is considered identical.

25. But can it be expected that nuclear and fossil-fueled power plants will yield identical services? Generally speaking, the answer to this question is “no.” This is due mainly to the fact that the difference in running costs of the two types of plants are such that the nuclear plant will tend to be assigned to base-load duty for a relatively major fraction (if not all) of its lifetime whereas the fossil-fueled plant, after an initial period when it also operates at high plant factor, will tend to be displaced upwards in the load diagram by

newer and more efficient plants. The lifetime plant factors of the two plants could thus be substantially different.

26. The possibility that an initial nuclear plant may itself be displaced by succeeding nuclear plants of the same or different design must also be considered. But it should be noted that one moves easily into the realm of pure speculation in considering some of the more exotic reactor types and possibilities: the achievement of breeder reactors and perhaps plutonium-burning reactors on an economic basis are two such possibilities having revolutionary implications. Nevertheless, some speculation of a less fanciful nature may still be useful, with attention limited to subsequent generations of presently "proven" reactor concepts.

27. It should first be noted once again that expected improvements in fuel technology can benefit existing as well as future generations of reactors. Within the limits of the constraints in the foregoing paragraph, it appears that the major difference between present and future generations of the so-called "proven" reactors may, therefore, be in their capital costs: future nuclear capital costs may decline markedly as compared to present levels although still remaining well above capital costs of conventional fossil-fueled plants; and in contrast to these differences, the differences in their respective fuel costs may be relatively minor.<sup>10</sup> The relatively small savings in fuel and other running costs that may be possible as between successive generations of nuclear plants might not justify the excess capital costs of a new nuclear plant as compared to a new conventional plant, if system growth required the addition of new capacity and if it were necessary to displace the former nuclear plant from base load by the newer one in order to give it a sufficiently high

plant factor. The additional capacity might therefore more cheaply be conventional. Existing nuclear plants may thus offer stiffer competition to future nuclear plants than existing conventional plants offer to future conventional plants in regard to "holding on" to their share of base load, and the opportunities for adding new nuclear capacity would tend to be limited by the existence of adequate base load to occupy it fully, without displacing existing nuclear capacity.<sup>11</sup>

28. What consequences does the difference in the probable lifetime plant factors of nuclear and conventional thermal plants have for cost comparisons? At first glance it might appear that the appropriate conditions for a nuclear-conventional cost comparison are to compute the generating costs of the nuclear plant at, say, an 80 percent plant factor, while those of the conventional plant are computed at 50 percent. (Although this assigns a plant factor to each plant that agrees with what appears to be the probable lifetime experience of each, it would, as shown below, be incorrect for comparison purposes and would be highly unfair to the conventional plant.)<sup>12</sup> On the other hand, to assume only a 50 percent plant factor for the nuclear plant or an 80 percent plant factor for the conventional plant appears to be unfair to the nuclear plant. The conceptually correct solution in this situation is, of course, to seek to compare the costs of providing the same stream of services in each case by broadening the area of the cost comparison to include the entire system in which either plant would operate. This solution may be called "system" rather than "plant-to-plant" costing.

29. In system costing it is theoretically necessary to project the evolution of the system load over the lifetime of the plant

in question, nominally 25 years, and to compare the total costs of supplying this demand for both alternatives, starting with existing capacity in the system and assuming in each case that an optimal sequence of succeeding plants is built and that the optimal pattern of plant loadings is followed. It should be noted that the optimal sequence of succeeding plants and the optimal loading pattern may differ in the two alternatives. In this undertaking it is necessary to make explicit allowance for future trends in fossil-fuel costs, for the technological evolution of conventional plants in respect of future heat rates and capital costs, and for the counterparts of these factors on the nuclear side. Since the streams of services yielded by each pattern of investments would by definition be identical, comparison of the present worth of all the future costs for each alternative permits a choice between the two on purely economic grounds.

30. It follows from the foregoing that the "costs" of a particular nuclear plant are not uniquely determined once the various parameters entering into the calculation of its generating costs are known. Various indirect costs to the system are associated with the installation of a nuclear plant as compared with a conventional plant, most obviously since the evolution of the system itself may be different in the two cases, and these, too, should be taken into account. But even if the evolution of the system is not altered, the installation of a nuclear plant which would probably remain at base load for a much longer period of time than would the alternative conventional plant could easily lead in each alternative to a different lifetime loading pattern for a succeeding plan which was identical in all other respects in the two

cases. In the conventional case this succeeding plant would "work its way" up through the entire base load before being displaced to a higher position in the load curve, while in the nuclear case the residence of any succeeding plant in the base load portion would be shorter because the nuclear plant would have preempted a part of the base load. Accordingly, the average lifetime plant factor of this succeeding plant would be slightly less in the nuclear case than in the conventional case, and its lifetime generating costs would therefore be slightly higher. This difference is attributable to the nuclear plant and in a nuclear-conventional cost comparison should properly be charged to it. In system costing, where the total system cost is computed in each case, these indirect cost effects are theoretically taken into account. In similar fashion, computation of total-system costs would take proper account of all the cost differences for each alternative resulting from an altered pattern of optimal capacity additions (i.e., different combinations of peak vs. base load plants) and optimal load assignments.

31. How does one take into account all of the problems and parameters involved in system costing? What are the practical implications of these suggestions? At one extreme it may well be necessary to employ an electronic computer to handle all the data and alternative investment programs possible in seeking to optimize the patterns of capacity expansions and plant loadings over a period of at least 25 years in the future. At the present time it is known that such calculations are regularly undertaken by various electric utility systems in the United States and Western Europe. In making such calculations, various shortcuts or approximation methods can be adopted, but it would

be outside the scope of this paper to list, summarize, or analyze them.<sup>13</sup> One set of studies that are being undertaken in one country, however, has led to the interesting conclusion that, *under the conditions of that country and the assumptions of those calculations* a plant-to-plant nuclear-conventional cost comparison (at the same high plant factor for both plants) yields cost conclusions not substantially different from what is gotten through more detailed (but still relatively simple) models. In part this is due to the fact that present worth computations tend to minimize the effects of differences of future costs. The present worth of the lifetime generating costs of an initial conventional thermal plant which is assumed to operate at a high plant factor will thus approximate the present worth of the generating costs of the succession of conventional thermal plants that will in turn provide the same base load service that the nuclear plant would provide during its lifetime. Because of the dampening effect of discounting future costs to present worth, other factors, such as expected changes in capital costs and in thermal efficiencies of the succession of conventional thermal plants, are of secondary significance.

32. It may be that the uncertainties surrounding the rate of progress of nuclear technology, no less than difficulties in projecting trends of fossil-fuel prices, make it pointless to proceed beyond the initial step of carrying out plant-to-plant cost comparisons. There must always be some balance between theory and practice in the sense that overly complicated theoretical models that put too much burden on uncertain data may serve little practical purpose. It is the essence of good theory to simplify a complex problem as much as

possible rather than to seek logical completeness.

33. While there is much merit in the foregoing position, it should not be overstressed. From an analytical point of view, construction of a theoretical model imposes a valuable logical discipline through the necessary spelling out of all relevant factors in the model. It is also useful in indicating the role and interrelations of significant variables and it helps focus attention on factors whose uncertainty is critical. As a practical matter, the availability of high-speed electronic computers makes it possible to handle large masses of data and to make repetitive runs under varying assumptions. Moreover, certain elements entering into system costing, such as the evolution of conventional power technology or the characteristics of growth in power demand in a well-established grid, can be projected with reasonable confidence. As for the more conjectural factors, it is possible to fall back on the use of ranges of possible values, establishing thereby critical limiting values beyond which the balance of a cost comparison may be shifted.

34. *Assumptions regarding taxes and other components of fixed costs.* The various fixed cost components of electric generating cost applicable to private utilities in the United States are shown in the following table. Although the size of each component varies to some extent (over time and as between utilities) depending on market conditions, local institutional factors, etc., its approximate significance can nevertheless be seen from the figures given, which may serve as representative averages for the recent past. The fixed charge rate is applied to the total capital cost of the plant, which yields an annual fixed cost, and this latter cost is

spread over the net power generation of the plant. Thus, for a plant costing \$145 per kw, the fixed charge at 14.5 percent is \$21 per year, and, if the plant operates 7,000 hours per year (producing 7,000 kwh per kw per year), which is equivalent to an 80 percent plant factor, the fixed charge per kwh would be derived as the ratio of the \$21 per year fixed cost to the 7,000 kwh of output during the year. This equals 3 mills (or 0.3 cents) per kwh, of which taxes and the cost of money may each represent about 1.2 or 1.3 mills per kwh.

*Approximate composition of fixed charge rate payable by private electric utilities in the United States*

<i>Component</i>	<i>Annual percentage of capital cost</i>
Cost of money.....	6.35*
Depreciation.....	1.19**
Taxes.....	5.85
Federal income taxes....	3.40
Other taxes.....	2.45
Interim replacements.....	0.35
Insurance.....	0.80
 Total.....	 14.54

\*As described further below, the figure shown is derived as a weighted average of interest on borrowed capital (50 percent of total weight), yield on preferred stocks (15 percent), and yield on common stocks (35 percent). These weights approximate the national average, and the figure shown assumes a yield of 4.5 percent on bonds, 5.0 percent on preferred stocks, and 9.6 percent on common stocks, which represented the yields on such securities at one point in the recent past.

\*\*Based on a 30-year sinking fund at 6.35 percent, the average cost of money shown above.

Source: Based on information supplied by the U.S. Federal Power Commission and the U.S. Atomic Energy Commission.

35. Certain aspects of this procedure are noteworthy, both in regard to electric-power costing outside the United States, generally, and more specifically in regard

to the applicability of the procedure to the costing of nuclear power. As regards power costing outside the United States, it is self-evident that both the rate and the composition of fixed charges specifically applicable to private utilities in the United States are not necessarily applicable in other countries, since they reflect at least in part institutional factors that are relevant only in the United States. In other countries, other institutional factors are operative. One may therefore question the common practice of uncritically applying U.S. costs and costing procedures to conditions elsewhere.

36. One institutional factor of major significance in power costing involves the question of utility ownership. Whereas electric utilities in the United States are, for the most part, privately owned and operated, although subject to controls by State and Federal regulatory agencies, electric utilities in many other countries are nationally owned and operated. This difference affects the rate each must pay for borrowed capital as well as their taxes or payments in lieu of taxes. On the average, in the United States only about half of the capital requirements of utilities may be raised by borrowing from the public through the sale of bonds. The balance must therefore be supplied from equity capital, with approximately 15 percent in preferred stocks and 35 percent in common stocks. A substantially higher rate of return is earned on equity capital than on borrowed capital because profits are "residual" and therefore riskier since they are not paid until all other costs, including interest on borrowed funds, have been paid first.<sup>14</sup> The weighted average of these rates of return is thus higher than the rate on borrowed capital alone, and this difference enters into the U.S. average fixed charge rate of about 14.5 per-

cent. It is obvious that the relevant rates in other countries depend on local institutional factors as well as on the rate of return applicable in the circumstances of that country to the types of capital employed.

37. While we can add little to the foregoing general remark that the institutional factors affecting the rate of fixed charges may vary widely throughout the world, it is possible to offer comment on the subject of the rates of return on capital employed in power production. For this purpose it is convenient to consider the rates on foreign and on domestic capital separately.

38. As regards foreign capital, it would appear, at first glance, that the proper interest rate to assume is the going rate on international loans of this type. At present the International Bank for Reconstruction and Development, the Export-Import Bank, and other sources of foreign investment are charging on the order of 6 percent for hard-currency loans. But, in certain circumstances, there can be entirely credible circumstances for applying a higher rate.

39. For certain countries it may not be unreasonable to assume that there exists a more or less fixed amount of foreign funds that will be made available to it by foreign investors each year.<sup>15</sup> A decision by the country in this case to select one type of investment, such as a nuclear power plant, in place of another requiring a substantially lesser capital outlay, necessarily involves adding to its foreign exchange demands in that year. This may result in postponing or cancelling other projects that would otherwise have been undertaken. If, however, it is decided to carry out the entire list of projects that would otherwise have been undertaken, then it becomes necessary to

borrow additional funds, presumably at less favorable terms, and it would then be entirely appropriate to charge these incremental capital costs to the nuclear plant. The reason for this is that with the overall limitation on foreign capital available at the more favorable rate, it is the decision to build the nuclear, rather than the conventional, plant that results in the necessity to obtain extra funds at a higher rate.<sup>16</sup>

40. With regard to domestic capital, it is usually argued that the proper rate of interest to be charged is the one at which the government can borrow funds locally. But the plausibility of this argument can be destroyed by the counter-argument that if the government chooses to raise all the funds required for a particular project through taxes, rather than through borrowing, no interest would be involved, hence no interest should be charged. It is easily seen that the same amount of domestic resources must be raised and diverted from other uses, regardless of whether they are raised through taxes or through a loan. Yet the "costs" of these resources are different in each case if the plausible line of reasoning advanced above is applied. What then should be the correct rate to assume?

41. The answer to this question can be given at a theoretical level, as follows: the cost attaching to a given amount of domestic capital that has been diverted from other applications—whether through taxes or through public borrowing is immaterial—is the yield which the same amount of capital would have earned in some other use. For many institutional, social, and political reasons, not all of which are peculiar to the less developed countries, that yield in percentage terms may be much larger than

the rate at which the government is able to borrow funds locally.<sup>17</sup>

42. A less theoretical answer to the foregoing question (of the correct interest rate on domestic capital) would require a detailed and extensive study of the circumstances in a given country at a particular point in time. Such a study would have to consider the pattern and structure of existing savings institutions and capital markets, if any, and to determine the maximum rate of economic growth in relation to the available resources that the population would be prepared to support through investment at the price of deferring current consumption. As a general proposition, however, considering the vastly lower levels of per capita income in less developed countries compared to the more industrialized countries, which permits little if any savings out of domestic income, the absence of organized institutional structures for channelling domestic savings into domestic investment, the paralyzing effects of inflation on domestic capital formation in some countries, and many other relevant factors, there seems little reason to doubt that the rate of return on domestic investment in most less developed countries is much higher than in the industrialized countries. This would put the rate at 10 percent at least, and possibly much higher, considering that it is of the order of 5 percent to 10 percent in Western Europe and the United States.

43. The magnitude of the taxes component of fixed charges in the United States has been referred to earlier. On the average the composite of federal, state, and local taxes contributes almost half of the 14½ percent fixed charges rate typically encountered. The previous comments about the non-applicability of U.S. institutional factors to electric power cost

comparisons in other countries are equally relevant in regard to taxes. But it is also pertinent to consider the effects of taxes on power cost comparisons from a somewhat different viewpoint, which involves the significant distinction between cost calculations carried out from the point of view of a private utility and from the point of view of the national economy.

44. A private utility choosing between a nuclear and a conventional power plant must obviously take the various taxes included in its fixed charge rate into account, since these charges represent costs to the utility. In the case of a nuclear plant in the 100–200 mw size range, the tax element in fixed charges may be twice as high as those of a conventional plant, simply because the capital costs of a nuclear plant in this size range are twice as high and because the costing procedure assesses the tax component of fixed charges as a percentage of capital costs. From the overall national economic point of view, however, this may not yield a fair cost comparison, for while taxes can often be considered as payments made by taxpayers for services rendered by the government, it is questionable whether twice as much services are rendered in the nuclear case than in the conventional case. Considering the importance of the tax element of generating costs, it is thus apparent that a fair cost comparison between a nuclear and a conventional plant from the national point of view can easily hinge on a valid assessment of the proper costs of government services in each case. In countries engaged in substantial programs of research and development of nuclear power, it may be legitimate to assign the costs of such activities to nuclear power generation, hence government services chargeable to a nuclear plant could be different than, and greater than, those

chargeable to a conventional plant. But in the case of countries not involved in such activities, particularly the less developed countries, government services are the same in both cases, hence the usual costing procedure requires a correction to avoid this particular bias.<sup>18</sup>

45. *Practical problems in estimating the major parameters in nuclear-conventional cost comparisons.* The variety of technical and economic parameters relevant in nuclear-conventional cost comparisons has been referred to earlier. As suggested, valid cost comparisons require reasonable long-range forecasts of their future values. Whereas the problems involved in making these forecasts are more or less the same throughout the world in the case of future prospects of conventional and nuclear-power technology and costs, there are significant differences between the more and the less industrialized countries as regards projections of future growth in electric-power demand. These differences will be explored below.

46. The phenomenon of chronic power shortages, rationing, and the recourse to dependence upon self-generated power is quite common in many of the less developed countries. These shortages occur mainly in the so-called industrialized enclaves of these countries, and they represent a manifestation of many of the special problems facing them.<sup>19</sup> On the supply side they are evidence of the lack of adequate capacity to keep up with the surging demand, while on the demand side they result from several factors explained below whose effects are not operative in the more industrialized countries.

47. One major factor on the demand side is the influence of the uneven pace of economic development in many less developed countries. Most new industrial

growth tends to concentrate in the industrial enclaves because of the existence there, and the absence elsewhere in the country, of some or all of the following: supply of labor, ready market, access to raw materials and transport facilities for finished products, credit availability, political stability, and, last but not least, reasonably priced and dependable electric power. Furthermore, the continuation of this process perpetuates an unbreakable circle of cause and effect, and industrial development remains concentrated in these areas. Aside from the undesirable political and social aspects of this process, it also focuses virtually all of the country's growth in electric power demand in one place, and this leads to a more rapid electric power growth rate at that location than if economic development were scattered throughout the country.

48. A second factor on the demand side that is not found in the more industrialized countries is the territorial growth of the electric utility serving the industrialized enclave. Where such expansion incorporates areas not previously electrified, it adds to the number of customers and to total electric-power sales. It is to be expected over time that this factor can lead to uneven, but rapid, rises in total sales. Territorial expansion may also result in the absorption of previously existing utility systems having extremely high-priced and low-quality service because of their small size, low-load factor, and their dependence on expensive diesel (or small steam) plant generation. Integration of these customers into a relatively modern grid supplying around-clock power at much reduced rates can easily lead to a rapid acceleration of their past growth in power consumption.

49. The combination of these factors, and of a number of other,<sup>20</sup> makes it haz-

ardous to interpret statistics of past consumption as "demand" and to project past growth rates based on these data into the future. Rather than reflecting demand, these data represent no more than the supply that was available to meet a somewhat greater demand. That this is so is clearly demonstrated in specific instances when consumption quickly accelerated after substantial generating capacity was added to the system and, in relatively short time, the previously existing shortage reappeared.

50. Having said this much, it is unfortunately true that an answer to the question of how to make better forecasts of future demand growth is not immediately obvious. A first step that is commonly taken is to add the estimated amount of unsatisfied demand to actual consumption totals and then to project the combined total at the growth rate of past consumption. But even if existing unsatisfied demand is correctly estimated, this procedure is potentially unsatisfactory on other grounds. The most obvious reason for this is the irrelevance of the past growth rate of available supply as a measure of the future, or, for that matter, of the past growth rate in demand: there is no assurance that the total of unsatisfied demand in the past always maintained a fixed proportion to actual consumption; yet this assumption is implicit in this projection procedure. Nor is it obvious that the past growth rate will continue. It is possible that the presumed future adequacy of generating capacity (a situation that did not prevail in the past, and with restrictive effects), could in fact accelerate the growth rate of demand by attracting industries to the grid area at an even faster rate than would otherwise prevail. In addition, industrial or other large power consumers that may have re-

sorted to self-generation in the past because the grid was unable to meet their electricity demands may well find it cheaper to turn to grid power if and when available. The addition of this element of "unsatisfied" demand to the unsatisfied demand of customers in areas formerly without electricity entirely or in areas served by high-cost, small utility systems can easily upset the projected overall demand growth rate and can in a few years lead once again to the reappearance of excess demand.

51. The importance of having reasonable forecasts of future demand, which may be much higher than would otherwise have been thought, is obvious in nuclear-conventional power plant cost comparisons. The more rapid the growth rate projected, the better the competitive prospects of nuclear power, since it permits consideration of the largest possible nuclear unit; economies of size are more pronounced in nuclear than in conventional thermal plants so that nuclear generating costs decline more rapidly as plants of increasing size are considered. In addition, the larger the total demand, and thus total system generating capacity, the easier it becomes to absorb a single large nuclear plant into a system in terms of normal standard of system reserve and dependability. But the problem of unsatisfied demand is relevant for nuclear-conventional cost comparisons in yet another regard, which is of special significance for the less developed countries. This concerns the plant factor and other parameters of plant performance assumed in the calculations of generating cost.

52. The obverse of a chronic shortage of generating capacity typical in many industrialized enclaves in less developed areas is a higher degree of plant utilization than would normally prevail. It is

thus quite common to find inefficient and obsolete thermal plants operating at a high plant factor because of the absence in the system of any alternative generating capacity in the face of unsatisfied demand. It is of course important and methodologically correct to study the costs of future additions to the system under assumptions of efficient planning and operation; as already suggested this has led to average lifetime plant factors of 50 percent and useful lifetimes of around 30 years for thermal plants in the case of more industrialized countries. But it would be unrealistic to assume that many of the problems described above will not continue to persist for a long time to come. Therefore, the expected lifetime plant factor of a conventional thermal plant to be installed in a typical power supply system in an industrialized enclave of a less developed country under these conditions would probably be higher than would occur under ideal and theoretical conditions. Furthermore, the plant's lifetime may be extended far beyond normal expectations. Alternatively, it is possible that its generating capacity may be pushed well beyond its nameplate rating at the cost of some reduction in its useful life. If all of these factors are relevant in regard to costing in the less developed countries, how should they be taken into account in making cost comparisons between nuclear and conventional plants?

53. The foregoing examples of instances where generating capacity may be employed more intensively than would be expected under ideal conditions suggest a curious paradox. It would appear that such (presumably non-economic) departures from ideal conditions actually reduce generating costs because the more intensive use of existing capacity results in

spreading its fixed costs over a greater output. And, in addition, it also appears that the competitive prospects of a nuclear power plant would be reduced in such a situation because of the apparent lowering of conventional power costs.

54. The key to this paradox is not hard to find. It rests in the meaning of the concept of "ideal (or optimal) solution." This may be defined, in general, as that combination of new capacity and loading pattern of all plants in the system which satisfy a given increase in power demand at least cost. But where the alternative of adding new capacity is precluded as a possibility (because of capital scarcity), a different optimal solution must be sought which, because it is more narrowly constrained, is less favorable than the unconstrained optimum. Thus, in using existing capacity more intensively than would otherwise be ideal in order to supply additional power to the system without adding new capacity, one does, in fact, reduce the cost of output from the existing plant. But, by definition, the ideal solution costs would have been even lower.

55. It should also be borne in mind that certain costs associated with the practice of using existing equipment more intensively in lieu of adding new capacity are not always immediately apparent. One of these involves conscious acceptance of lowered system reserve standards, at the price of greater interruptions to service. The losses or inconveniences of such interruptions are felt by the utility and its customers alike. Similarly, one can not neglect considering the costs to industrial consumers and to the national economy associated with the practice of suppressing industrial demand at peak hours, which helps build up plant factors and thus apparently to reduce generating costs. The lowered costs of the plant that

is being used more intensively are thus imperfect indexes of the true costs that are being borne elsewhere.

56. Nuclear power enters into this picture as one of the several possible alternative types of new capacity that should be considered in seeking a least cost solution. And if it is, in fact, the optimal choice in a given situation, it would remain so, regardless of whether or not the system is operated in such a way as to attain this optimum. The several instances cited above of more intensive utilization of generating capacity in some circumstances are therefore essentially irrelevant in regard to the assumptions underlying a fair cost comparison of alternative types of new capacity, although they would not be irrelevant if one wished to determine the cost of not adding new capacity, i.e., of failing to select the most optimum solution.

### Summary

57. In this paper we have considered a number of theoretical and practical problems in costing nuclear and conventional power plants, as well as their particular significance for less developed areas. The fact that economic conditions in countries at an early stage of industrialization are sufficiently different from those in more advanced countries to call for adjustments in key costing factors has not always been fully appreciated. In some cases the differences and the necessary adjustments may be quite significant.

58. Most generally, the central theme of this paper has been the necessity for adapting costing procedures and specifying costing parameters that are relevant to the conditions of the country and the power system to which they refer. So far as nuclear power is concerned, the

paper suggests that in undertaking cost comparisons between nuclear and conventional power plants one should not ignore those differences between nuclear and conventional power plants which can reasonably be expected to affect the terms of the comparison.

59. One essential difference between nuclear and conventional power plants involves the probable lifetime load duties that may be assigned to each. Because of the substantially different composition of nuclear generating costs, where running costs would be well below those of even the most efficient conventional plants, it appears likely that the nuclear plant will be assigned to base load duty for essentially all of its service life, in contrast to the slowly changing load assignment of conventional plants. This difference, which resembles somewhat the difference between the lifetime load duty of a hydro-plant and a conventional plant in a mixed hydro-thermal system, suggests that simple plant-to-plant cost comparisons may offer only preliminary and essentially incomplete information because each plant will yield a substantially different stream of services. Instead, it is argued—similar to the requirements of a hydro-thermal cost comparison—that the differences between nuclear and conventional power plants make it necessary to undertake system costing. The paper also considers other implications of the foregoing differences between nuclear and conventional plants.

60. A second factor of major importance in power costing, especially in cost comparisons carried out in less industrialized countries, concerns the various components of the rate of fixed charges and the differences between conditions affecting these components in the United States and in other countries. The two

most important elements of fixed charges in the United States are taxes and the rate of return on capital investment. While the rate of return on capital is normally much higher in most less industrialized countries than it is in the United States, institutional factors affecting plant ownership and operation may work in the opposite direction; whereas electric power is mainly privately owned in the United States, and a large share of the capital must be equity capital which requires a much higher rate of return than capital that is borrowed through the sale of bonds, in many other countries electric power is government-owned and the capital needs of electric utilities can be supplied from government funds. This can help lower the cost of money below what it would be if the U.S. requirements regarding capital were operative, although it would be reasonable to expect that the cost of money component of fixed charges will remain above that in the United States, regardless of the influence of this purely institutional factor. As regards the influence of taxes on electric generating costs, it is noted that these represent over 40 percent of the rate of fixed charges in the United States, so that differences in the incidence and rates of taxes can lead to significant differences in power costs in other countries. In addition, an attempt was made to identify the role of taxes in cost comparisons carried out from the point of view of private utilities and from the national economy, and it was suggested that consideration of both viewpoints is essential in evaluating and formulating national economic policy, particularly in the less industrialized countries.

61. Power supply and demand conditions in less-developed countries differ in various respects from their counterparts

in the more industrialized countries, and these differences are also relevant in making nuclear-conventional cost comparisons. One consequence of the capital scarcity typical of many less developed countries is the chronic existence of power deficits in the industrialized enclaves of these countries, with the necessity to ration power through a suppression of demand at times of peak loads and to operate the system with inadequate reserve capacity. For this reason, and for others given in the paper, over the course of time, power consumption statistics fail to reflect what power demand would have been had there been no deficiency of generating capacity, and they therefore fail to reflect the trend of growth in demand in the past, which is necessary for making projections of future demand. Yet such projections are essential in undertaking cost comparisons of future plants in the system, since they affect the question of the maximum plant size to consider and the plant factor to assign it—both of which are highly pertinent in the case of a nuclear plant.

62. The factors cited herein, and others that could be identified if there were sufficient time and space, are directly relevant in power plant costing, regardless of whether it is carried out by a privately owned utility or by national planning authorities. It has been argued that these factors are especially relevant in regard to power planning in the less industrialized countries, considering their narrow economic basis and the importance of making the optimum use of their scarce capital resources. The present Conference is concerned primarily with the technical modifications that may be required in adapting for the benefit of less industrialized economies scientific and technological developments which have

emerged out of the needs of the more industrialized countries. It is but a logical extension of this aim, considering the intimately interrelated nature of technology and economics, to consider also the comparable economic adaptations that may be required in costing procedures and parameters.

### FOOTNOTES

<sup>1</sup> The reader is referred to the following documents in regard to the cost-accounting aspects of electric power: Federal Power Commission, *Uniform System of Accounts Prescribed for Public Utilities and Licensees (Class A and B)*, Washington, D.C., January 1, 1961; and International Atomic Energy Agency, *Introduction to Methods of Estimating Nuclear Power Generating Costs*, Vienna, 1961.

<sup>2</sup> This statement requires further qualification to allow for the influence of transmission and start-up costs. It may be more economical for a plant to generate power required at a nearby load center even though a slightly lower generating cost is possible in another plant further away. In similar fashion it is necessary to compare the relative start-up costs of particular plants before deciding which can supply a given load most economically.

<sup>3</sup> A numerical example may demonstrate more clearly than is possible in words alone how the displacement from base load occurs. Assume a system expanding at an annual rate of 10 percent, with expected peak demands of 1,000 mw in 1965, and 1,100 mw in 1966. If the system wishes to maintain a 10 percent reserve above peak load, its total capacity must be 1,100 mw in 1965 and 1,210 mw in 1966. Thus 110 mw of new capacity, which may for the present purposes be assumed to be a single new plant, will have to be added between 1965 and 1966. Assume further that system base load is also growing at 10 percent per annum and is expected to be 300 mw in 1965 and 330 mw in 1966. The growth in base load will therefore add 30 mw during 1966, and the addition of the new 110 mw plant to the 300 mw of capacity that was used for base load duty in 1965 will mean that 80 mw out of that 300 mw total will no longer be required for base load duty.

<sup>4</sup> An alternative formulation sometimes suggested which is not at all the same, and which is less tenable since it is not clearly a cost of *the existing plant*, is that the amortization charge should be adequate to set aside sufficient funds to replace the plant with an equivalent plant after it has been retired. Because of the influence of technological changes and of long-run changes in the general price level, it is often difficult to decide how much needs to be set aside under this formulation.

<sup>5</sup> A distinction should be drawn between the period corresponding to the life of the plant and the period within which the financial charges are to be paid off. The latter depends on the terms of the particular loan and are costs that must be met by the plant; but it would be incorrect to include this period in the cost calculations in lieu of the plant's lifetime.

<sup>6</sup> The rate of physical obsolescence is dependent on the degree of plant utilization, which, in turn, determines the plant factor. Thus, assumptions about expected lifetime average plant factor and expected useful life are interrelated.

<sup>7</sup> It is obvious that some maintenance will be carried on even if the plant doesn't

operate at all, for example maintenance that may be required because of weather conditions. Furthermore, some fuel is consumed in keeping a plant "warm" even though it may not be called upon to produce any power but is only being kept in reserve. These costs could be included under fixed costs in a strict interpretation and for a detailed analysis, but for present purposes such precision is unnecessary. It may also be noted that running costs vary somewhat in relation to plant factor and that, corresponding to the plant's most efficient rate of output, there is a minimum point in the curve of heat rate (i.e., fuel consumption per kwh generated) plotted against level of electric-power production. Furthermore, plants often vary in their ability to follow load variations—some plants cannot increase their output as rapidly as others in response to an increase in demand. These and other considerations can thus be seen to preclude a strict proportional relationship between running costs and plant factor.

<sup>8</sup> We ignore, at this point, the question of comparing the expected costs and the expected revenues from each alternative plant, and merely assume that, the decision to build one or the other plant having been taken, the remaining problem is to determine the most economic alternative.

<sup>9</sup> Because there are greater economies of scale in a nuclear than in a conventional plant, the ratios of their capital costs are less than this for plants above the 100–200 mw size range, and they are greater than this for plants below this size range. Although there is a wide range of circumstances surrounding the power supply and demand situations in countries around the world, it may still be useful to consider, as a first approximation, that the 100–200 mw range approximately covers the size of nuclear plants most likely to be of economic interest to the less developed countries during the next 10 to 15 years. Plants larger than this may be too large to be efficiently absorbed into the electric supply systems of most such countries, even though their competitive cost prospects may otherwise be more favorable, while, in contrast, the excess capital cost burden of a nuclear plant substantially smaller than 100 mw, as compared with a conventional alternative, may in most cases be too great to be offset by savings in fuel costs, except in locations with extremely high conventional fuel costs.

<sup>10</sup> One important line of research and development in nuclear technology at present is directed to achieving higher fuel burn-up rates, hence greater fuel efficiencies, by means of fuel elements able to withstand higher temperatures. The applicability of these improvements to older reactors depends largely on the capacity of the thermal system in the nuclear plant to handle higher temperatures as well as on the capacity of the turbo-generator to increase its power output; hence, only if provision were made for them at the time the plant was built would improvements of this type be applicable. On the other hand, cost reductions in fuel element fabrication and in reprocessing will be applicable to new and old reactors alike, as will also increases in fuel burn-up rates through improvements in fuel cladding technology and in fuel management procedures. It is, of course, impossible to quantify these two categories of improvements, but it should not be forgotten that the cost reduction possible in successive generations of reactors are relatively small to start with because the fuel cost component of a nuclear plant is itself a relatively small part of total generating cost. The application of im-

provements in fuel technology to existing plants will diminish this margin of difference further.

<sup>11</sup> It should be noted that this argument rests on a number of highly technical and presently conjectural assumptions, and might have to be modified somewhat in response to major changes in these assumptions. One of these assumptions is that nuclear plants will continue to be substantially more capital costly than conventional plants. Secondly, as has already been suggested, the argument ignores the possible effects of reactors, such as breeders, offering sharply reduced fuel costs. Finally, no account is taken of the gradual slowdown in conventional power plant technology and of a possible decline in the growth rate of electric power demand, both of which could contribute to higher plant factors for conventional plants as well as to a changing pattern of new-capacity additions to existing systems.

<sup>12</sup> This possibility was recently suggested by the U.S. Atomic Energy Commission: “\* \* \* one might conceivably compare nuclear and fossil plants using a higher load factor for the nuclear plant. This would reduce the fixed charges for the nuclear plant and make it still more competitive.” (Statement made at the request of U.S. Congress, Joint Committee on Atomic Energy, June 25, 1962, and quoted in Atomic Industrial Forum, *Forum Memo*, August 1962, p. 5, paragraph 3.)

<sup>13</sup> The International Atomic Energy Agency is presently studying this question, including the various shortcut and approximation methods (such as those referred to in paragraph 31), but it is not known at present how soon it will be in a position to report on its findings.

<sup>14</sup> As shown in the following table which is based on estimates prepared by the U.S. Federal Power Commission, the yield in the United States on bonds in recent years has been about half that on common stocks, and the weighted average of the yields on bonds, common stocks, and preferred stocks has been between 30 and 50 percent above the yield on bonds alone.

Date	Bonds	Stocks		Weighted average
		Preferred	Common	
Jan. 1, 1958.....	4.00	4.635	9.443	6.00
Jan. 1, 1959.....	4.50	5.00	9.57	6.35
Jan. 1, 1960.....	5.00	5.50	9.79	6.75

Source: U.S. Atomic Energy Commission, *Costs of Nuclear Power* (TID-8531), January 1961, p. 20.

<sup>15</sup> Subject to numerous qualifications, this may be a useful, though highly simplified description of the foreign assistance offered India by the Aid Consortium.

<sup>16</sup> Alternatively, if the decision to build a nuclear plant forces a postponement or cancellation of some other plant, then it would be theoretically correct to charge the nuclear plant with some share of the foregone profits of the plant that is not built. This charge may or may not be greater than the extra cost due to the

necessity to seek additional capital funds at a higher rate of interest; and it could even be negative in case the displaced plant was ill-conceived and would have resulted in a loss.

<sup>17</sup> One apparent consequence of the foregoing fallacy, which often leads to an undervaluation of domestic capital in economic planning in the less developed countries, is that electric power development, as well as other forms of social overhead capital provided by the state, are subsidized. However, given the importance of rapid electrification in economic development and the many intangible benefits which cannot be quantified in any cost-benefit comparison, this unconscious element of subsidy (which leads to a more rapid development of electric power supply) is perhaps a good thing. But, it may also help explain why local capital is not attracted by the yield offered by private electric utilities in many less developed countries, preferring instead to earn greater returns in land speculation or other "nonproductive" investments.

<sup>18</sup> Note that the fuel-cost component of total generating cost would be expected to include various costs resulting from government inspection and other services, hence these should not be counted twice.

<sup>19</sup> It should be emphasized at this point that the present discussion is solely concerned with the so-called industrialized enclaves in less developed countries, as distinct from remote areas or areas with scattered and unconnected electricity supplies, and that the basic conditions of power supply and demand in each such type of situation are fundamentally different. An interesting and useful discussion of these and related questions will be found in "Characteristic Features of the Power Situation in Less-Developed Countries," by J. Barnea and E. S. de Breuvery, Resources and Transport Branch, United Nations, paper presented to Conference on Small and Medium Power Reactors, Vienna, 1960, and appearing on pp. 337-356 of *Small and Medium Power Reactors*, Vol. II of Conference Proceedings, International Atomic Energy Agency, Vienna, 1961.

<sup>20</sup> An additional factor possibly affecting growth in electricity consumption is the effect of inflation on the relative price of electricity (where rates are more or less controlled and hence cannot adjust rapidly to the changing level of other prices) as compared with the relative prices of other forms of energy. This tends to lower the price of electricity as compared to the other energy forms (which are able to vary more freely) and may encourage a long-run substitution to electricity.

# Techniques for Appraising the Energy Economy and Outlook in Less Developed Countries\*

NATHANIEL B. GUYOL

*Senior Staff Economist, Standard Oil Company of California, San Francisco, California*

1. The purpose of this paper is to outline one approach to energy planning and forecasting and discuss its applicability to the less developed countries of the world.

2. The approach consists mainly of the construction of a complete energy balance for the country under consideration; appraisal of the influence of various physical, economic and institutional factors upon this balance; and application of the understandings thereby gained to the problems of planning and forecasting.

3. The energy balance is a device that has proven particularly useful in the collection and organization of data on the physical aspects of the energy economy. It is in fact nothing more or less than a consolidated account for all sources of energy, in which the several sources used in a particular area during a stipulated period of time are expressed in a common unit and brought together in a single table or graph. Fully developed, the energy balance traces each source of energy from origin to effective use, showing at each stage in this flow the physical

and functional interrelationships of the several energy sources.

4. This analytical tool has come into rather wide use during the past decade, but mainly for countries that get most of their energy from sources that enter normal trade channels and are duly recorded—that is, the so-called commercial sources of energy. Among these countries are Austria (1), Belgium (2), Bulgaria (3), Canada (4), Germany (5), Italy (6), the Netherlands (7), Spain (8), and the United States (9).

5. There is at least one case, however, in which an energy balance has been constructed for a country that depends primarily upon non-commercial sources of energy. This case is India, whose energy balance is shown graphically in figure I, and statistically in table 1 (10).

6. The chart and the table demonstrate the importance of noncommercial sources of energy, including even draft animals, in less developed countries. In this particular case, it should be noted that draft cattle provide nearly as much *power* as all other sources of energy combined, and noncommercial fuels, such as firewood and dung, more *heat* than all other sources of energy combined.

\*U.N. Conference paper.

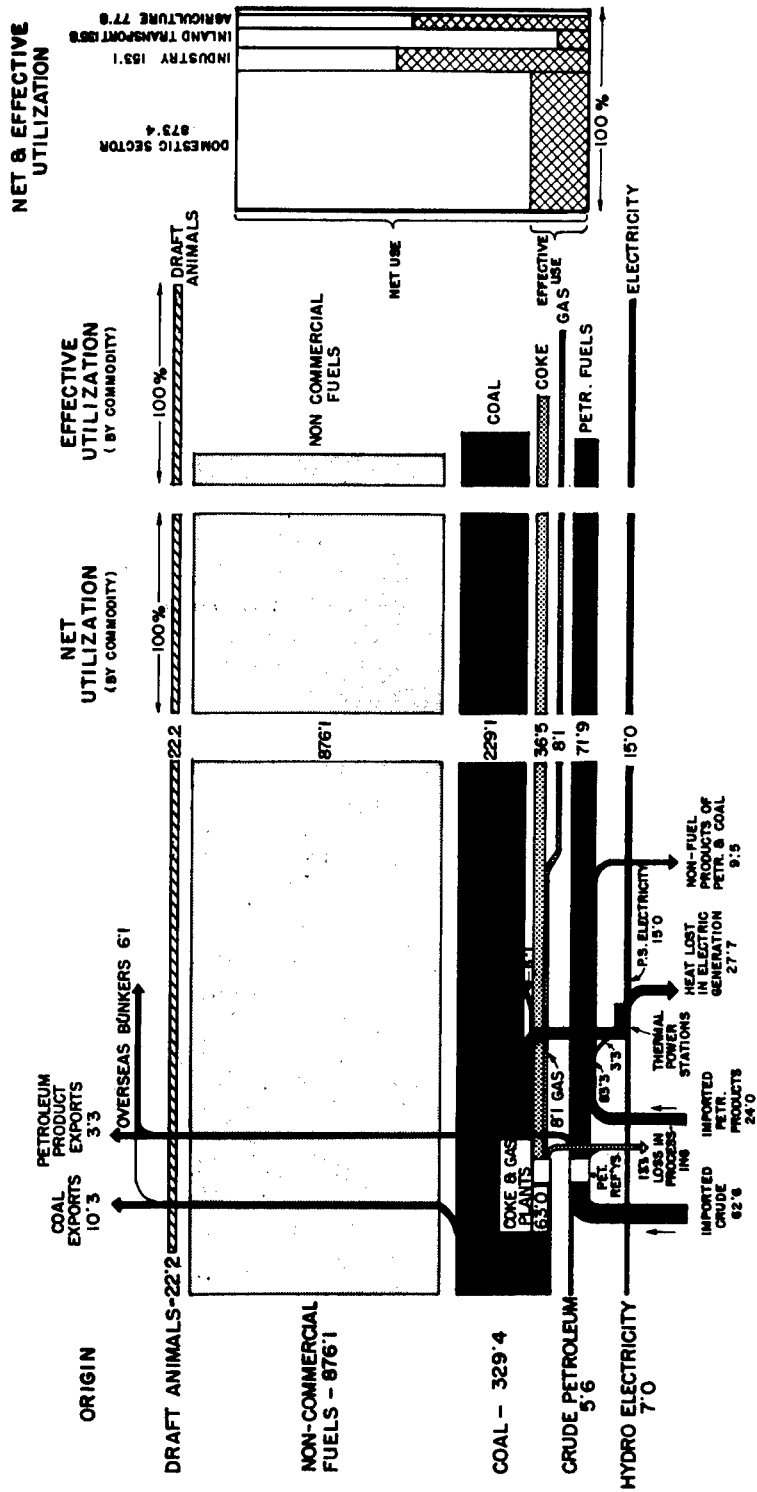

FIGURE 1. Origin and utilization of energy in India—1959. (Data in million megawatt-hours, electricity equivalent.)

7. The main point in presenting the chart, however, is to demonstrate that energy balances *can* be constructed for less developed countries when needed. So far as commercial sources of energy are concerned, it is, in fact, somewhat easier to prepare accounts for less developed than for developed countries. The volumes to be accounted for are smaller; the flow from production or imports to end-use is ordinarily simpler, and the pattern of distribution is usually less diverse.

8. On the other hand, balances for less developed countries are complicated somewhat by the necessity of including noncommercial sources of energy, especially when the work output of draft animals must also be taken into account. This is not as difficult as it may seem, for supply and demand of energy from these sources can be estimated, with accuracy that suffices for most purposes, by methods developed in the Statistical Office of the United Nations (11) and the U.S. Department of State (12).

9. The most difficult problem that arises, in both developed and less developed countries, is that of estimating the quantities of energy *effectively* used—that is, the amount of energy converted to useful heat, light or power. The importance of this calculation cannot be over-emphasized, because the real costs of energy are determined as much by efficiency of use as they are by prices. Diesel oil, for example, is far more expensive per unit of contained energy than is coal, but as a locomotive fuel it costs less than coal per unit of work performed because of the relatively high efficiency with which it is used.

10. Reasonable approximations of effective use, satisfactory for most purposes, can be obtained by the application of standard efficiency factors to data on

energy supplied to various consumer groups. The efficiency factors needed can be obtained from any one of a number of studies such as the United Nations paper on World Energy Requirements in 1975 and 2000 (13), and the papers previously referred to in (2), (6), and (9). Standard factors such as these can sometimes be improved upon, however, by special surveys of combustion practices and results (14).

11. *National* energy balances such as those described above provide most of the data needed concerning physical aspects of the energy economy, especially where the country dealt with is small. In large countries such as India, these can be usefully supplemented by *regional* energy accounts, especially when patterns of energy supply and demand vary significantly from one region to another.

12. The usefulness of both national and regional accounts is considerably enhanced when they can be repeated for a series of years, thus affording a basis for computing historical rates of growth in production, consumption, or other phases of supply and demand.

13. For planning purposes, data on energy reserves are needed, especially data on the location of mineral fuel deposits and water power sites that are readily accessible to domestic markets and can be developed at relatively low cost.

14. Energy balances provide a useful panorama of the energy situation. When repeated for a series of years and supplemented by data on energy reserves, they also provide some understanding of why the energy economy operates as it does. For a more complete understanding, it is necessary to consider also certain other factors which affect the energy economy—*economic* and *institutional* factors in particular.

15. Costs are among the factors to which particular attention must be given—mainly costs to consumers, but also costs to the economy as a whole and costs to the country in foreign exchange.

16. Data on costs appear to be relatively rare, but a surprising volume of such data can be assembled through systematic research within the area under study. In India, for example, it was found possible to obtain data on the costs of energy to industrial establishments, railways, power systems, households, airlines, gas works, and motor-vehicle operators. It was also found possible to obtain data on pithead prices of coal, on prices of petroleum products at refineries and distribution depots, on costs as well as charges for moving coal by rail, on charges for moving fuels by ship, on the aggregate values of fuels imported and exported, and on taxes on petroleum products and coal. Altogether, enough data were available to reveal the structure of energy costs in each sector of the economy and each major portion of India.

17. Institutional factors that affect the energy economy include the *agencies* responsible for managing portions of the energy economy, the *instruments* through which control is exercised, such as price controls, taxes, and subsidies; and the *will* of the government and the people to develop the national economy.

18. Data on institutional factors are not sought through separate research, but are accumulated in the course of normal research on physical and economic aspects of the energy economy. Some, such as taxes and subsidies, are brought to light through studies of the structure of prices or costs. Others are indicated simply by deviations of the supply-demand pattern from its expected course. As a rule, institutional factors tend to stand out in the

publicly operated branches of the energy economy, and to fade into the background under private enterprise.

19. With data on the physical, economic, and institutional aspects of the energy economy in hand, an analysis of the energy situation becomes possible. This appraisal can be addressed initially to the single question: are consumers getting the energy they require? If they are not, there is need for immediate action to find out why not and what can be done to see that they get what they need practically *regardless of cost*. The penalty paid for any energy shortage normally exceeds by far, in terms of production, the costs of energy itself.

20. As a rule, it is fairly easy to find out whether consumers are getting the energy they require. Shortages, when they occur, have rather dramatic consequences, such as the closing down of industrial establishments, rationing, load shedding, and rapidly rising prices. They are therefore likely to be given considerable prominence in the press and other news media.

21. Attention must also be focussed on the costs of energy to consumers, to the economy as a whole, and to the country. Costs to the economy as a whole may be defined as consumer costs adjusted upwards to correct for subsidies and downwards to correct for taxes. Costs to the country may be defined as the net gains or losses in foreign exchange that result from the purchase of energy from foreign sources.

22. It is *relative* costs that are important to consumers and to the economy as a whole. The real question is one of whether energy is being made available to the two groups at as low a cost as possible, taking into account relative efficiencies of use as well as relative prices of the several

energy sources. As previously indicated, the importance of taking efficiencies of use into account cannot be overemphasized.

23. The appraisals described above will have brought to light many of the problems and opportunities facing the energy economy. They will thereby have created a sound basis for energy planning, the objective of which is to maximize the contribution of energy to the development of less developed areas.

24. A somewhat different approach is needed for forecasting, because forecasting is concerned with things as they are *likely* to be rather than things as they *should* be.

25. One basis for forecasting is provided by data on historical trends in demand or supply of energy. The value of such data is extremely limited, however, because of potential changes in the fuels used and in the efficiency with which they are used. As a rule, the main value of trend data is in indicating prob-

able upper and lower limits to the development of supply or demand.

26. Forecasts of national product also provide a basis for estimating future needs and supplies of energy, but only on the basis of the historical relationship of energy to national product. The results obtained by this device are no more satisfactory than simple projections of the energy curves.

27. To get really satisfactory forecasts it is necessary to take into account, in addition to historical trends, various economic and institutional factors that influence energy demand and supply. The real problem is to ascertain how much weight should be given to each of the factors affecting demand or supply. In private-enterprise economies, where economic forces have relatively free play, the pendulum is likely to swing toward economic factors. In public enterprise economies, institutional factors are more likely to dominate. But there is no hard-and-fast rule to guide the forecaster. He must, finally, weigh intuitively that which he cannot weigh mathematically.

TABLE I. *India's energy balance, 1959*  
[In Million MWH Electricity or Equivalent]

	Coal	Coke	Coal gas	Crude oil	LPG	Avgas	Jet fuel	Mogas	Kero.	Dist. F/O	Resid. F/O	Ref. fuel & loss	Non-fuel prod-ucts	P.S. elect.	All comm. sources	Non-comm. fuels	Inani-mate sources	Draft power	All sources
Primary Production.....	329.4			5.6										7.0	342.0	876.1	1,218.1	22.2	1,240.3
Secondary Production.....		42.5	8.1		0.1			12.2	9.5	17.7	19.9	4.0	4.3	8.0	126.3		126.3		126.3
Net Import.....	-9.7	-0.5		63.1		1.1	1.8	-1.8	14.7	2.8	-1.5		3.7		73.7		73.7		73.7
Gross Consumption.....	319.7	-0.5		68.7		1.1	1.8	-1.8	14.7	2.8	-1.5		3.7	7.0	415.7	876.1	1,291.8	22.2	1,314.0
Overseas Bunkers.....	1.0					0.3	0.3			0.3	4.3				6.2		6.2		6.2
Gross Inland Consumption.....	318.7	-0.5		68.7		0.8	1.5	-1.8	14.7	2.5	-5.8		3.7	7.0	409.5	876.1	1,285.6	22.2	1,307.8
Processed In—																			
Coke Ovens.....	43.3														43.3		43.3		43.3
Gas Works.....	1.3														1.3		1.3		1.3
Soft Coke Works.....	18.7														18.7		18.7		18.7
Petr. Refineries.....				68.7											68.7		68.7		68.7
P.S. Elect. Works.....	32.2									1.3	2.1				35.6		35.6		35.6
Total.....	95.5			68.7						1.3	2.1				167.6		167.6		167.6
Net Inland Consumption.....	229.1	36.5	8.1		0.1	0.8	1.5	10.4	24.2	18.9	12.0	4.0	8.0	15.0	368.7	876.1	1,244.8	22.2	1,267.0
Utilization (Input):																			
Transportation.....	108.8						1.5	10.4		13.3	0.8			0.5	136.1		136.1	1.0	137.1
Industry.....	95.3	21.9	7.8							2.9	10.7	4.0		9.0	151.6	1.5	153.1		153.1
Domestic Sector.....	4.8	13.1	0.3						23.7					2.7	44.7	828.7	873.4		873.4
Agriculture.....	6.4								0.5	2.7	0.6			0.7	10.9	45.9	56.8	21.2	78.0
Nonfuel.....		1.4											8.0		9.4		9.4		9.4
Lost and Not Accounted.....	13.8	0.1												2.1	16.0		16.0		16.0
Total.....	229.1	36.5	8.1		0.1	0.8	1.5	10.4	24.2	20.2	14.1	4.0	8.0	15.0	372.0	876.1	1,244.8	22.2	1,270.3
Utilization (Output):																			
Transportation.....	6.8						0.2	1.0		1.8	1.0			0.5	11.4		11.4	1.0	12.4
Industry.....	52.4	12.0	6.2							0.9	6.4	2.4		-2.0	78.3	0.6	78.9		78.9
Domestic Sector.....	1.4	3.9	0.2					1.6						1.4	8.6	124.3	132.9		132.9
Agriculture.....	2.5							0.1		0.5	0.3			0.7	4.1	13.8	17.9	21.2	39.1

Total	63.1	15.9	6.4	0.1	0.1	0.2	1.0	1.7	3.2	7.7	2.4	0.6	102.4	138.7	241.1	22.2	263.3
Heat	58.0	15.9	6.4	0.1	0.1	0.2	1.0	1.2	3.2	6.7	2.4	-13.8	76.9	138.7	215.6	22.2	215.6
Power and Light	5.1				0.1	0.2	1.0	0.5	3.2	1.0		14.4	25.5		25.5	22.2	47.7

1 Including 5.6 from oven coke and 0.4 accounting difference.  
 2 Excluding 6.3 transferred to coal/soft coke; including 0.7 transferred from oven coke.  
 3 Including 1.3 converted to electricity.  
 4 Including 2.0 converted to electricity.  
 5 Including 3.3 converted to electricity.

Source: National Council of Applied Economic Research.

LPG = Liquefied Petroleum Gas

Mogas = Motor Gasoline

Dist. F/O = Distillate Fuel Oil

Ref. Fuel & Loss = Refinery Fuel & Loss

All Comm. Sources = All Commercial

Sources

Avgas = Aviation Gasoline

Kero. = Kerosene

Resid. F/O = Residual Fuel Oil

P.S. Elect. = Public Supply Electricity

Non-Comm. Fuels = Non-Commercial

Fuels

## REFERENCES

- (1) Austria. Bundesministerium für Verkehr und Wiederaufbau, *Osterreichische Energiebilanz für das Jahr, 1953*, Vienna (1955).
- (2) Marchal, G. H., *Bilan énergétique de la Belgique*, Annales des mines de Belgique, Brussels. (Annual)
- (3) Georgiev, D. A., B. St. Kostov, *d'energie complet de la R. P. de Bulgarie pour les années 1956-57*, Sofia (1961).
- (4) Davis, J., *Canadian energy prospects*, Royal Commission on Canada's Economic Prospects, Ottawa (1957).
- (5) Arbeitsgemeinschaft deutscher wirtschaftswissenschaftlicher Forschungsinstitute e. V., *Untersuchung über die Entwicklung der gegenwertigen und zukünftigen Struktur von Angebot und Nachfrage in der Energiewirtschaft der Bundesrepublik unter besonderer Berücksichtigung des Steinkohlenbergbaus. Juni 1959*, Duncker & Humblot, Berlin (1962).
- (6) Società Edison, *Il bilancio energetico Italiano nel 1960*, Quaderni di studi e notizie, 343, Milan (16 July, 1961).
- (7) Netherlands. Centraal Planbureau, *Production and consumption of energy in the Netherlands in 1947*, The Hague. (Chart.)
- (8) Spain. Ministerio de Industria, *Balance y estructura de la produccion y el consumo de energia en España*, Madrid (1956).
- (9) Barnett, H. J. *Energy Uses and Supplies: 1939, 1947, 1965*. Washington: GPO, 1950. Department of the Interior, Bureau of Mines, Information Circular 7582.
- (10) The chart and table are based on studies prepared in 1961 by the National Council of Applied Economic Research, New Delhi.
- (11) United Nations. Statistical Office, *World energy supplies in selected years, 1929-1950*, Statistical papers, I-1, New York (September, 1952).
- (12) U.S. Department of State, *Energy resources of the world*, U.S. Government Printing Office, Washington (1949).
- (13) United Nations. Department of Economic and Social Affairs, *World energy requirements in 1975 and 2000*, International Conference on the Peaceful Uses of Atomic Energy: Proceedings, I, New York (1956).
- (14) A good example of such surveys is the survey of household fuel efficiencies conducted for the National Council of Applied Economic Research in India and reported upon in *Domestic fuels in India*.

WATER AND RIVER BASIN  
DEVELOPMENT

## Introduction

Every individual is dependent upon water for his life. Every society—of man, lower animal, and plant—is equally dependent upon water for its existence. Without this substance, life, agriculture, and industry perish. Where and when water occurs, how it is husbanded, how it is protected and distributed, become significant and vital matters of interest to the individual and to the community.

The developing countries may now draw upon the scientific and technologic resources of other countries for speeding up the process of stocktaking and the creation of water programs. The United States has had experience with progressive, small- and large-scale development of water projects spanning some 175 years. Its steps in technology, in institutional management, and in fiscal design may be applied with appropriate adjustment to other regions of the world.

The papers here presented have been selected to illustrate the spectrum of water development from the community level to the broader regional, river-basin and rivers systems. Many of these developments in the United States naturally reflect the geologic, geographic, topographic, and climatologic characteristics of the country. It is a complex of large rivers, humid and semi-arid areas, mountains and great plains—posing virtually all the issues likely to confront most of the less developed countries. The solutions or practices here presented are naturally a composite of ad hoc improvisations, imaginative engineering adjustments, balancing of local, state and national responsibilities and autonomies, and inevitable concessions to special interest groups. The last of these is obviously the universal attribute of all societies, where they consist of people.

Throughout all these rehearsals of experience in the United States run strong evolutionary principles and practices in governmental and private approaches to water projects. As intensive agriculture developed, as irrigation grew, as urbanization and industrialization made new demands on water quantity and quality, new forms of attack, new government structures, and new financial adjustments were made. It should be emphasized that none of these changes, installations, and procedures was accomplished overnight. Long periods of gestation, of debate, of design and execution exemplify the whole history of North American water development. The present status was not a spontaneous, instantaneous phenomenon. It took more than a century and a half to materialize. Developing countries should be able to telescope time somewhat, but not to disregard it.

Some of the subject matter covered may be briefly delineated here. The underpinning of all water development lies in the availability of hydrologic data, their sound interpretation, and then matured application to project design. Hendricks, Langbein, and Taylor review the implications and methodologies of hydrologic data—precipitation, snow cover, surface and ground water, sediment, chemical quality, evaporation, and soil moisture. The significant conclusion of this contribution is that: "One can-

not afford to defer the collection of hydrologic data—until specific questions arise for specific areas and problems.” The authors do, however, show how action may proceed intelligently even with less than complete data by the use of modern statistical tools and by reasoned projections of past records even where meager.

The evolution of the community water system—ample water of safe quality in every home—is described by Wolman and Bosch. Eighteen thousand systems now serve some 135 million people. They have been developed almost entirely by local initiative, and have been financed and managed locally. They represent an accomplishment over a period of about a century. By their growth, water-borne diseases, such as typhoid fever, have been virtually eliminated from the American scene. The costs per person have been and still are extremely modest, averaging less than \$10 per person per year and covering interest, amortization, maintenance, and operation.

The recognition of the high importance of water to millions of people throughout the world accounts for the high priority afforded the program for promoting community water-supply development by the U.S. Agency for International Development. As Swisher points out: “Today, piped water in the home is still a dream to the major part of the world’s population.” The objective of A.I.D. is to speed up the realization of this dream by special cooperative efforts with some 42 countries.

The place of the water system in the framework of economic development is emphasized by Swisher, while its significance in reducing disease is by no means ignored. These vital relationships are reflected in the great emphasis placed upon water in the work of the World Health Organization and the Pan American Health Organization.

As water use increases, the inevitable problem of handling of waste waters arises, with even the ultimate re-use of such wastes. Such efforts will presuppose improved processes of waste-water treatment. Gloyna discusses one of these low-cost waste-treatment processes, namely, waste-stabilization ponds. Such units may be constructed with local materials and are peculiarly suited to places where land is relatively inexpensive, operating personnel are inexperienced, and construction funds are severely limited. Some 50 years’ experience is available in the United States. Upon the basis of these rich data, Gloyna maps out quantitative criteria and design factors for such units.

Although only one process is here discussed, many other treatment programs have been in use in the United States for more than half a century. For large and small populations these processes provide many guide lines for adaptation to other countries.

River-basin planning likewise reflects an experience evolved over some 150 years. The evolution is described by Weber of the Corps of Engineers and Hufschmidt of Harvard University. As in any developing country, the earliest plans were often for a single purpose, such as navigation, flood control, or irrigation. Modern concepts of multipurpose river-basin approaches began to crystallize at about the turn of this century. It was only about the late 1930’s that the river basin came to be accepted as a hydrologic and physiographic planning unit.

Major river basin developments are here examined to reveal the mechanisms underlying the establishment of goals and the selection of projects in such basins as the Tennessee, Columbia, Missouri, and the Delaware. The experiences derived from such projects as these disclose the importance of clear delineation of objectives, of relating regional economic targets to national ones, of the use of sound benefit-cost analysis for both tangible and intangible effects, and of considering a basin plan as a part of total investment planning for all sectors of the economy. Where and when river-basin plan and project fit into the development program of a country must be determined by a review of all the factors here described. No single formula appears to fit every circumstance at every stage of a country's economic rise.

Ground-water resources development provides one of the richest sources of supply in the United States. Similar major opportunities for such uses are apparent in many countries. Todd contributes to the understanding of ground-water exploration and development in his summary of the increasing contributions to this effort by the great advances in science and technology. Recent research has opened new vistas in evaluation of ground-water flow, in the use of radioisotopes, computers, geophysical equipment, and aerial photographs.

These techniques have been supplemented by hydrobotanic studies and improved well-logging procedures and drilling equipment. Tritium provides a convenient new tool for tracing the movement of water under ground. The successful artificial recharge of water into the ground and the protection of aquifers against sea-water intrusion have been greatly facilitated by scientific advances of recent years.

All of the developments point to the availability of improved, more rapid, and more widely applicable methods for underground water detection and use. Since so many countries have these untapped resources, the technologic progress Todd describes has virtually universal applicability.

An example of joint government effort in this field is delineated by Haworth in the ground-water exploration project for northeastern Thailand. This is jointly financed by the Thai and U.S. Governments. It is designed to evaluate the ground-water potential of the area, to provide for development of ground-water supplies, and for the training of Thai personnel in ground-water investigation and methods of drilling. Ground water is one of Thailand's valuable natural resources.

In similar fashion, the United States interest in translating irrigation principles and practices is exemplified in the contribution by Greenman on "Hydrology and Scientific Reclamation in the Punjab, West Pakistan." The Punjab represents one of the oldest areas of irrigation in the world, where practices evolved from primitive flooding methods to modern weir-controlled canals. Not unexpectedly, here too some of the most severe irrigation problems have ensued. Of the 13.5 million acres under irrigation, more than 8 million are measurably affected by salinity and water-logging. Salinity is encroaching upon new lands at the rate of about 100 thousand acres per year. Crop yields are lower than world averages even on unaffected lands.

The West Pakistan Water and Power Development Authority, in cooperation with the U.S. Agency for International Development, is carrying out a massive program of reclamation and development. It is based upon a vast network of some 25

thousand wells and well drainage. The whole program poses one of the greatest challenges in water-resources management known to the world.

Almost every country in the world shares with the United States the eternal problem of safeguarding its people and its material resources against perennial and catastrophic floods. In this area of effort, the lessons of the United States are highly significant.

White and Cook point out that the attempt to reduce flood losses, while permitting unrestricted development of flood-plain lands, has been costly. Less highly developed countries need not repeat these unfortunate lessons. With these purposes in mind, the history of floods and flood control and the various methods used to reduce flood damages are discussed. Special emphasis is given to the necessity of regulating the use of flood-plain lands, so as to maximize their contribution to national income.

Man has always been intrigued by the hope of "sweetening the sea." In many areas, the supplies of fresh water are insufficient to meet increasing demands. Some of these regions have easy access to the sea or to reserves of brackish water. What are the practicable merits of recovery of fresh water from these sources by desalination?

Sherwood and Wexler review these and other potentials for extending the water resources of the United States and of the world. Their general conclusion is that the cost of water obtained by present processes is too high to make desalination useful in most situations. They suggest that further engineering refinements of the present processes will probably not lead to the low-cost water needed for the development of industry and agriculture in arid lands. It is hoped, however, that basic research will ultimately result in better and less expensive desalination processes.

With respect to evaporation-reduction techniques, a number of problems must be solved before large-scale application will be economically feasible. Similar reflections are made with respect to both "rain-making" potential and large-scale weather modification. These do not give too much ground for optimistic support for fresh-water supplementation in the near future.

The key to the intelligent development and management of water resources lies in the availability of scientifically trained hydrologists. Curiously enough, such persons are in acutely short supply in the United States and for the most part in almost all other countries. Harshberger directs himself in his paper to the pressing problem of education and training. He stresses the wide scope required, since hydrology is the science that treats of the waters of the earth, their occurrence and circulation, their chemical and physical properties, and their reaction with their animate and inanimate environments. "The domain of hydrology embraces the full history of water on the earth."

The challenge to universities to modify and elaborate their programs to train students along these essential broad fronts is posed by Harshberger. Already such efforts are being initiated at a number of universities. They will undoubtedly be paralleled elsewhere and adapted to local and national requirements.

In conclusion, the job of translating principles and policies into working structures and machinery falls to the water engineer, who puts concrete, steel, brick and earth to the beneficial uses of man. The design and construction of large works for regimentation and use of water are demanding tasks, which have been extensively carried out in the United States. Exposition at the Geneva Conference of this aspect of water development is being made primarily by means of films, which readily show the embodiment of ideas in social realities.

Dr. ABEL WOLMAN

*Professor Emeritus of Sanitary Engineering and Water Resources  
The Johns Hopkins University  
Baltimore, Maryland*

# New Steps Toward Better Data and Investigation for Water Resources Development\*

E. L. HENDRICKS, *Assistant Chief, Water Resources Division*; W. B. LANGBEIN, *Staff Scientist*; and, G. C. TAYLOR, JR., *Chief, Section of Foreign Hydrology, U.S. Geological Survey, Washington, D. C.*

## Introduction

1. We have learned that the way in which we develop water resources affects the good or ill of mankind. Flow-regulation can provide water for irrigation, the control of floods, or generation of power. On the other hand, irrigation can generate salinity problems; the construction of a dam induces changes in river morphology, and the consequences of these changes are costly. Some effects are slow and subtle. Pumping of ground water sooner or later affects streamflow and restricts use of river water.

2. Understanding of such causes and effects—part of today's slowly gained knowledge of water development—is small indeed compared with the vast objectives and problems that lie ahead. We are a long way from any glamorous ways to obtain large quantities of cheap water of high quality as by rain-making or desalinization. Water must be obtained in the natural environment. To obtain water, then, one must know the environment, and this knowledge is obtained through hydrologic data and study.

3. The domain of man's activity transects all arcs of the water circle. Hydrologic data are therefore of many kinds—observations of precipitation, snow cover, surface water, ground water, sediment transport, chemical quality, evaporation, soil moisture, and many others. The certainty of this need for hydrologic data in the accelerating water development throughout the world has created a growing interest in improving methods for collecting these records, for their interpretation, and for their use in solving our problems. To illustrate these techniques, we have focused attention on some of the principal hydrologic data on precipitation, surface water, and ground water.

4. The importance of hydrologic data is underscored by the fact that the sounder the data, the more complete the records, the greater is the part of the resource that can be developed. The first bucket of water can be obtained easily enough. But as more and more water must be supplied, one needs to know exactly how much water there is available. In the case of surface water, there is the added difficulty that it is a fluctuating resource, and one

\*U.N. Conference paper.

must know more of the range and degree of fluctuation to be expected.

5. Many of the newly developing countries are in the arid zones, where there is need to impound water for long periods of time. Long-term hydrologic records must be available in order to assess correctly the amount of storage needed. There is no way to avoid or circumvent this necessity. Overbuilding can offer no way out, because the water to utilize excess storage capacity may not materialize. Some major storage reservoirs have already experienced serious difficulties because of unanticipated shifts in the pattern of river flow, and it is suspected that several newer multipurpose river schemes have yet to meet tests of their adequacy.

6. New mathematical models have been developed for using hydrologic records so as better to determine amounts of storage for regulating river flow, but in each case the application of the model depends on adequate records.

7. Concentration of sediments and dissolved mineral matter increases with aridity. Silt and salinity are problems everywhere but are most troublesome in the arid zone. Neglect of the silt and salt balance can impair, if not destroy, an irrigation scheme.

8. Because of great variation in the flow of different rivers, it is essential to obtain records at every proposed or potential site. This readily leads to a large program of river measurement. To collect the necessary information economically, methods have been developed for automation of the reduction of the records, and for extending short or even spot measurements. These methods will be described.

9. Ground water is a more stable resource, but it is out of sight and therefore not subject to direct measurement. Methods of geophysical exploration or

hydraulic analysis must be applied. The effective boundary and the response of a ground-water reservoir, for example, can be determined only through aquifer-pumping tests. This analysis can be greatly expedited by means of analogue models, to be described.

10. Hydrologic observations provide data for many purposes, all of which need to be considered in planning a program. On the other hand, it is not possible to anticipate the nature of all future hydrologic inquiries. Moreover, one cannot afford to defer the collection of hydrologic data or the launching of hydrologic studies until specific questions arise for specific areas and problems. Time—often years—is required to collect adequate data. Experience has proved the necessity for a core program, as in a national basic network that is adaptable to the solution of a wide variety of problems. Methods will be described for the design of such networks.

### Precipitation

11. As the source of all fresh water, precipitation is an important hydrologic factor. It is at once the easiest and one of the most difficult hydrologic phenomena to measure.

12. Precipitation at a place can be measured in an open vessel—the idea is ancient, and records of rainfall extend back nearly two centuries. Variations in the type of rain gauge have been introduced. The three main types are recording rain gauges, for measuring minute-by-minute intensity as well as amount of rainfall; standard rain gauges, in which the catch is read daily; and seasonal gauges, usually placed in mountainous or remote regions, which store the catch over several-month intervals between

readings. National networks must contain all three types of gauges, and the Hydrologic Commission of the World Meteorological Organization is at work to devise principles adaptable to design of such networks.

13. The hydrologic problem, however, is to assess rainfall over an area during short periods of time, as during the development of a flood. In general, the accuracy of an areal assessment is proportional to about the 0.6 power of the number of gauges. This means that the number of gauges must increase faster than accuracy, so that to obtain reliable estimates a rather dense network becomes necessary. And even if such a dense network were attainable, there remains the problem of obtaining current information during the progress of a storm. These are the factors that make accurate measurement of the areal distribution of precipitation difficult.

14. Radar equipment has been developed to meet these hydrologic and associated meteorological needs.<sup>1</sup> Adequate radar equipment used by experienced operators can not only provide an instantaneous picture of rainfall intensity, but also furnish data for extrapolating a few total-catch gauge measurements into an accurate storm isohyetal map. Furthermore, radar permits estimates of rain intensity and total storm precipitation to be made over terrain where standard rain gauges are impractical.

15. The ability of weather radar to sense rainfall depends on the interaction of high-frequency electromagnetic waves and water drops in the atmosphere. When a high-frequency radio wave impinges on a parcel of air containing water drops, some energy is scattered in all directions by individual drops and some passes through. The net effect of a

cloud of particles on a high-frequency radio wave is to reflect some energy and pass some through. The ratio of energy reflected and of energy passing through to the initial energy of the wave depends on frequency of the wave, number of droplets, size of droplets, and size of cloud.

16. For a fixed operating frequency, the theoretical strength of the signal reflected back to the radar,  $Pr$ , may be expressed as

$$Pr = \frac{KNd^6 Pt}{R^2}$$

where  $K$  is a constant for a given equipment,

$N$  is a number of raindrops per unit volume,

$d$  is diameter of raindrops,

$Pt$  is a power transmitted,

and  $R$  is the distance from radar set to raindrops.

It is evident that heavy rainfalls, for which the values  $Nd^6$  are large, would reflect back extremely strong signals. Also, because of the range factor, that a nearby light rainfall may give as strong an echo (the signal reflected back to the radar set) as a heavy distant rainfall. To obtain a usable echo from light rainfall at distant range, high power must be transmitted. However, the transmitter power required is a function of radar-beam spread—a sharp beam will penetrate farther than a less sharp beam.

17. The maximum practical range of a radar set is limited by the earth's curvature. Although refraction of the radio waves in the atmosphere bends the transmitted rays slightly below the optical line of sight, the net result is that the center of a radar beam rises to an elevation of 15 thousand feet at 160 nautical miles. Thus, there is a practical limit to the

maximum range of a radar set, because increases in range from increases in transmitter power result in loss of distant echoes from lower elevations.

18. The oscilloscope screens of the U.S. Weather Bureau WSR-57 radar (figure I) have phosphorescence with persistence that indicates a time-average picture of conditions. The indicator displays may be visualized by considering the signal indications that would come from a hypothetical metal sheet suspended in the sky. Thus, the "P.P.I." scope displays a circular map of echoes centered about the radar set, the "A" scope shows the distance to and intensity of echoes, and the "R.H.I." scope shows a vertical view of the echoes along an azimuth.

19. The radar operator may use either of two methods for recording the areal distribution and intensity of rainfall. He may mark the areal limits of the storm and the isoecho patterns on a transparent sheet placed over the P.P.I. scope (overlay method), or he may use a camera to photograph the P.P.I. scope (multiple-exposure method). The record of the storm consists of maps or photos taken at equal intervals during the time the storm is within range of the set.

20. The operator using the overlay method places a transparent sheet with a grid ruled on it over the P.P.I. scope face. He starts with receiver gain "full on" and places a tick mark in each square of the grid that is filled or partially filled with precipitation echo. Then he reduces receiver sensitivity (control set for 33 db attenuation) and again tick-marks the squares with echoes. After three repetitions at further reduced receiver sensitivity (48, 60, and 66 db attenuation), he has sufficient information to sketch in the isoecho patterns. The isoecho pat-

tern represents the nearly instantaneous map of precipitation echoes—from these data and information received from recording rain gauges under the storm (such information may come from a radio rain gauge that is triggered by the radar beam and displayed in symbol form on the P.P.I. scope) the operator must interpret the isoecho map into an estimate of quantitative rain intensity. The overlay method is repeated at 10- to 15-minute intervals. An experienced operator can make reliable estimates about the flood potential of the rainstorm under observation and will send appropriate warnings in case of a flood threat.

21. Multiple-exposure photography consists of re-exposing the same film at selected intervals, the camera being focused on the P.P.I. scope and a shutter setting used so that a display during one revolution of the radar antenna is recorded at each interval. A composite picture, varying in density according to the intensity of rain echoes photographed, may be made of any time segment of the storm. Approximately the same techniques as were used by the overlay method are used in interpreting the photographs.

### Ground Water

22. During the past decade, important emphasis has been given to the development of ground water in the newly emerging nations, particularly those in the arid regions of the world. Optimum utilization of the resource demands adequate appraisal through collection of relevant data by appropriate surveys and the analysis and synthesis of such data, both before and subsequent to development. Ground water, of course, is a phase of the hydrologic cycle, but the investigation of this water involves techniques and methods

that may be distinctly different from those appropriate to other phases of the cycle. The study of ground water entails evaluation of the interrelations of the biological, physical, and chemical characteristics of the water in terms of its geological environment as well as other phases of the hydrologic cycle, both in time and in space. Such study includes as important elements the areal occurrence, rate and direction of movement, the natural recharge-discharge balance, the geochemical balance of dissolved solids in the water resulting from natural and artificial causes, and the hydraulic response of aquifers to manmade changes in the natural regimen.

23. The techniques employed in ground-water investigations depend in large measure on the relative sophistication, complexity, and scope of the actual or proposed development of a ground-water system. A total evaluation might include surface and subsurface geological, surface and subsurface geophysical, geochemical, hydraulic, and hydrologic studies. However, a simpler ground-water investigation might include only a few selected elements from among these. Good aerial photography and topographic maps are fundamental to all surveys related to ground water. Also, as the rocks are the natural reservoirs in which ground water is stored and the natural conduits through which it circulates, knowledge of the geologic framework of a ground-water system is essential to its understanding. Surface and subsurface geologic surveys provide important information on the areal distribution and structural features, such as faults, folds, and unconformities, of water-bearing formations (aquifers) and associated impermeable formations (aquicludes) that affect the head, direction, and rate of

movement of ground-water systems; the quality of the water obtained; and the design of development programs.

24. In recent years, geophysical studies have been used to increasing extent in quantitative and semiquantitative evaluations of ground-water systems. Among surface geophysical methods, electrical-resistivity, seismic, aeromagnetic, gravimetric, and sonar surveys are employed with varying degrees of success. Surface electrical-resistivity surveys are used successfully in one-, two-, and even three-layer systems, where marked discontinuities occur in the electrical-resistivity profile and where the thickness of each layer is appreciable in relation to the depth of the discontinuity. Such surveys are particularly useful in establishing fresh water-salt water interfaces in coastal aquifers. Seismic surveys are used mainly to map discontinuities between impermeable bedrock and overlying water-bearing unconsolidated or semi-consolidated sediments. The method is adequate only where there is a marked contrast in the elastic properties of the two types of rock. Aeromagnetic and gravimetric methods are also used to locate buried bedrock surfaces where appreciable discontinuities in rock magnetism and density exist in two-layer systems. Although these methods are not widely used in ground-water problems in the United States, they have found considerable application in countries of the Eastern Hemisphere. Aeromagnetic methods are particularly useful where rapid reconnaissance delineation of aquifers is required over broad regions. Mapping of bedrock surfaces and thickness of unconsolidated overlying deposits by techniques and equipment using low-frequency sound waves also is finding increasing application, particularly in

underwater problems in coastal areas. The principles employed are the same as those used in sonic depth finders.

25. Subsurface or borehole geophysical methods are now widely employed in practically all moderately intensive or detailed ground-water investigations. Electrical logging is perhaps the most useful tool in distinguishing aquifer contacts, formational porosity, water quality, and fresh-salt water interfaces in uncased boreholes. Also, this method can be used quantitatively, if other supplementary field data are available. Gamma-ray and neutron logging is also increasingly used for stratigraphic correlation, particularly between cased wells. However, proper interpretation of such radiation logs requires considerable antecedent knowledge of the local lithology. Limestones and dolomites, for example, have radioactive intensities similar to sandstone.

26. The importance of depth-temperature relations in ground-water systems is increasingly recognized, particularly with respect to water viscosity and the effective permeability of aquifers. An important tool in the analysis of these relations is the temperature log, which utilizes conventional electric logging circuits to measure resistance change of a temperature-sensitive metallic conductor. By this method, which can be used in both cased and uncased wells, a temperature log and a corresponding reciprocal-gradient log are derived. From these logs it is possible to identify the aquifer or aquifers tapped by wells. Borehole diameter or caliper logging is an important tool in long-range stratigraphic or aquifer correlation. The caliper log is also used to determine the condition of an underreamed section of a borehole prior to placement of a gravel pack and well cas-

ing, and to estimate the volume of cement necessary to fill the annular space between the well casing and the borehole wall.

This technique is based on variation of borehole diameter which reflects differences in the lithologic character of the rocks penetrated by the drill. Another borehole technique of wide application is flow-meter logging which provides a record of the velocity and direction of movement of water in a well. The log may be made while the well is discharging water at the land surface, while water is being introduced, or while the well is idle. The flow-meter log serves to identify and evaluate the aquifers tapped by cased wells having multiple screens, leaks in cased wells, and permeable zones penetrated by cased wells. Still another borehole technique is fluid-conductivity logging which provides a record of the electrical conductivity of the borehole fluid at all depths. Such a log provides useful information on the position of salt-water leaks in cased artesian wells and the depth and relative artesian head of salt-water aquifers penetrated by cased wells. Still more recently, compact television cameras with wide-angle lenses of short focal length are being designed for on-site inspection of well casings and examination of the lithologic character of borehole surfaces.

27. Perhaps the most sophisticated technique now in use in the laboratory analysis of simulated ground-water systems and the effects of manmade changes on these systems is the passive-element analogue model which is based on the direct analogy between electric and fluid force fields. (See figure II.) For any ground-water system, an analogue model employing resistor-capacitor networks with analyzers can be constructed, with a degree of complexity depending on the

nature of the ground-water system and the available basic data. In the model, the fundamental aquifer variable (transmissibility) is simulated electrically by capacitance. The electric analogue model affords a useful means for computing the distribution of potential (or head) at any point in the system under complex boundary conditions as well as variable recharge and withdrawal by pumping.

28. The chemical characteristics of ground water are very important with respect to its utilization as well as with respect to geochemical methods for analyzing ground-water systems. Identifiable chemical constituents in minute concentration are particularly useful in tracing the direction and velocity of water movement through the rock skeleton but must be used in conjunction with adequate geologic and hydrologic knowledge of the ground-water system. Induced tracers such as salt solutions, fluorescein, and radioactive materials commonly are used for this purpose. Also radioisotopes, such as carbon-14 and tritium, are proving useful in determining the relative age of water in different parts of a ground-water system and the span of the "life cycle" of such a system. Chemical quality and temperature relationships also enter into the quantitative evaluation of other ground-water problems, including salt-fresh water relationships in coastal aquifers, base exchange, influx of mineralized waters or brines, aquifers as heat exchangers, induced infiltration, artificial recharge, and disposal of radioactive wastes.

29. Hydraulically, an aquifer serves a dual role as a transmission conduit and a storage reservoir. As a conduit, it transports water from areas of intake to centers of interception by wells or to areas of natural discharge such as the sea, a

stream, a lake, a marsh, or a drain or locale of evapotranspirative consumption. In its role as a storage reservoir the aquifer provides a reserve that may sustain base flow in streams or well discharge during extended periods when net intake from precipitation is exceeded by the aggregate discharge of wells; leakage to the sea, to springs, drains, or streams, and consumptive use in vegetated areas. Because of the importance of the transmission and storage characteristics in the hydraulic behaviour of aquifers and ground-water systems, a considerable number of methods have been evolved for the mathematical analysis of problems in fluid mechanics as they apply to ground-water flow systems. To enumerate, well methods of aquifer evaluation include those involving constant discharge or recharge without vertical leakage, instantaneous discharge or recharge, constant head without vertical leakage, constant discharge with vertical leakage, and variable discharge without vertical leakage. Channel or drain methods include those applicable to constant discharge, constant head, and sinusoidal head fluctuations. Numerical analysis and flow-net analysis provide the chief areal methods of aquifer evaluation. Also, the analysis of hydrologic boundary problems has been built on a number of methods involving the theory of images.

30. Quantitative evaluation of ground-water systems by hydrologic methods has had a considerably longer history of evolution in the United States than the development and use of hydraulic methods. Appraisal of the ground-water resource requires an accounting of the perennial intake, discharge, and changes in storage with relation to man's existing and future needs for ground-water supplies. In addition, water quality must

be adequately defined with regard to temporal and spatial changes in ground-water systems and the effects of such changes on man's use of the water. Among the seepage methods for evaluating the recharge-discharge balance in ground-water systems are seepage surveys keyed to streamflow records from gauging stations and analysis of stream hydrograph analysis, and water-budget studies. Methods for estimating recharge or discharge from changes in ground-water storage include lysimeter or tank studies, observation-well hydrographs, isopachous maps of net change in water level, saturation or drainage techniques, and indirect methods. In all storage methods, specific yield must be known to convert changes in storage volume to water volume.

### Surface Water

31. A most significant development in the collection of hydrologic data in the United States in the past decade has been that of a digital recorder for the measurement of river stages. These instruments punch a digitized record of water level on a paper tape in a manner compatible with systems of computation by high-speed digital computers. The records may be used with any of several stage-sensing devices—floats, pressure transducers, or gas-purge (bubble gauge) systems of head-pressure sensing.

32. The records-processing program begins with a stage record obtained from a digital-recorder gauge (see figure III) and ends with a computer print-out listing mean daily discharge rates, computed monthly and annual averages, maximum and minimum rates of flow during monthly and annual periods, and flood-

hydrograph data for floods meeting pre-selected criteria.

33. The entire processing procedure is called a "gauge to page" plan, for almost the entire process is accomplished by the use of machines, the only human factor being the introduction of judgment factors into the programming of computer operations. The print-out from the computer is ready for reproduction by photographic methods for formal publication.

34. The normal engineering and judgment factors are applied in the analysis of the periodic discharge measurements, to determine stage-discharge relationships and to assign adjustments to stage to accommodate changes in these relationships. The procedure, in brief, begins with a stage-sensing device installed at the gauging site on a river, which activates a digital recorder to punch a digitized record of stage on a paper tape. This record on paper tape is translated by machine to magnetic tape in appropriate computer language. A program is designed for a high-speed computer which takes the magnetic tape, combines it in the computer operations with the programmed commands for stage-discharge relationships and the desired discharge products, and proceeds to perform all commanded operations and print out the results. Using the techniques described, it is now possible to compute an entire discharge gauging-station record for a year in only a few minutes, whereas the same operations performed by hand require many hours.

35. A second significant development in the collection of river data in the United States is the invention of a stage-sensing device called a "bubble gauge." This gauge (figure IV) was developed to record reservoir and river levels without the

use of stilling wells and intake pipes, which are often expensive to construct and difficult to maintain. The gauge consists of a specially designed servomanometer, a transistorized control, a gas-purge system, and a recorder. The pressure corresponding to the head of water is brought to the manometer by the gas-purge system. Nitrogen gas is discharged slowly through plastic tubing from the gauge house to an orifice located at a fixed elevation in the stream. The pressure at the orifice, and hence at any point in the delving tube, is related to the head or depth of water over the orifice. This pressure is in turn transferred to the manometer and then to the recording device. The manometers have a sensitivity of  $\pm 0.005$  foot, and the entire assemblage can be constructed to record ranges in stage in excess of 120 feet. A differential type of manometer may be adapted to the instrument to record directly the slope in a short reach of river channel.

36. Several new field instruments are undergoing development and field tests in the United States, and will soon significantly influence data-collection techniques. One of these is a velocity meter based on measurement of the electromagnetic effect of flowing water. This meter will generally be adapted to the continuous measurement of water velocity at preselected points. An acoustic velocity meter is being tested, which will measure the mean velocity in a line across a stream channel. The meter is based on the Doppler principle and relates water velocity to the difference in travel time of ultrasonic waves moving in opposite directions between transducers located across the stream from each other and offset from each other in a longitudinal direction. We are also attempting to develop a small portable current meter

based on the Doppler principle. The Doppler effect is evident in a change in frequency of an emitted signal due to motion of the water and suspended sediment with respect to the meter. The meter, which gives a direct reading of velocity, appears to be particularly applicable to the measurement of very low stream velocities. The instrument will be fully transistorized and battery-powered, resulting in a light portable device admirably suited to use by field personnel.

37. A special depth-sounding and velocity-measuring device has been developed for measuring extreme flood flows. This instrument combines a fathometer, a direction compass, and a Price current meter, and permits measurements of depth, direction of current, and near-surface velocity with a single setting and without encountering the hazards of complete depth sounding by sounding weight. The technique of augmenting continuous flood records by operation of only crest-stage gauges has been enhanced by the development of a small, cheap (\$50) water-stage recorder. This recorder may be operated intermittently in a 3-inch pipe well to obtain only flood hydrographs.

38. Streamflow data-collection programs in the United States include provision for determinations of suspended sediment and chemical quality of river flow. Water-temperature measurements are a routine part of water-quality observations. As in the collection of flow data, techniques for collection and analysis of water samples have been refined in recent years. Newer methods for chemical analysis of water include such instrumental techniques as spectrophotometry and flame photometry. Increasing emphasis is being given to develop-

ment of techniques for measuring trace elements. During recent years several models and sizes of depth-integrating samplers have been developed to permit accurate and efficient sampling of sediment suspended in river flow. A depth-integrating sampler is moved vertically through the sampling zone at a constant rate and admits a water-sediment mixture at a velocity about equal to the stream velocity at all points of its travel. Other samplers have been developed to sample continuously at a point and to collect bed material for particle-size examination.

39. Much effort is being expended in the United States in the development of techniques of analysis for the generalization and synthesis of streamflow data. It is never possible to collect information at all potential sites of need. The problem usually faced requires generalization of existing data in such manner as to form a basis for the synthesis of flow data at ungauged sites to acceptable limits of accuracy. For example, methods for generalizing flood experience have been developed. One of these procedures uses statistical methods to choose geographic areas within which flood generation and probability are homogeneous. Flood experiences at all stations within these areas are composited to develop flood-frequency curves of much broader base than possible from records for a single station. The sizes of floods generated within these areas are expressed as ratios to the mean annual flood. The single-size parameter, the mean annual flood, is related graphically to drainage-area size and other topographic factors. To determine the size of a design flood in an ungauged area by this method, the following steps are taken: (a) determine the mean annual flood for the stream in question, using the graphical relationships and the appli-

cable topographic factors, (b) derive the ratio of the design flood to the mean annual flood from the composite flood-frequency curve for the area in which the stream is located, and (c) multiply the mean annual flood determined in step (a) by the ratio determined in step (b).

40. Several other more or less sophisticated methods of generalizing flood experience are in common use. The choice between them usually depends on the amount of basic data at hand and on the personal preference of those engaged in the study.

41. Techniques for the generalization of other streamflow data, such as mean annual runoff or low-flow quantities, are in common use in the United States. The description of even a sample of these techniques is not possible here.

42. Perhaps the most difficult problem facing water-data program planners is the design of adequate networks for the collection of field measurements. Intuitive and judgment factors are utilized in beginning such networks. Appropriate weight is given to sampling areas having differing terrains, geology, and climate, and to existing needs for data at specific sites. As techniques are improved, and the needs for data increase, networks are expanded.

43. Several years ago the network of streamflow and water-quality gauging stations in the United States had grown to such proportions that it was necessary to evaluate the entire program. The principal classifications of stations derived from this and subsequent studies follow: (a) primary stations, those having essential hydrologic significance and operated for indefinitely long periods, (b) secondary stations, those at which continuous flow records are obtained for a period of only a few years (5 to 10), and

(c) partial-record stations, those at which flows, or stages, are measured only during extremes of either high or low conditions.

44. In testing the existing design of primary gauging stations, statistical methods were used to determine the degree of independence of stations in the network. With these criteria it was possible to eliminate some stations and to pinpoint new areas needing gauging. Thus, the optimum extent of the required primary network was determined.

45. The principal rationale in the use of networks of secondary and partial-record stations is to obtain a maximum amount of data at minimum cost. Modern statistical methods in hydrology permit records from these shorter or less complete operations to be extrapolated to accurate estimates of flow parameters for

longer periods. Networks of such stations become more dense as water development proceeds in an area and the need for more detailed hydrologic information increases.

46. A final consideration in the responsibility of a government to furnish hydrologic data for its own use and that of its citizens is the preservation of the data in a place and in a form useful and available to all. Our emphasis in the United States is on data accurate by high technical standards, centrally filed, permanently preserved, and readily available. High consideration is given to the introduction of new techniques where they have promise of adding accuracy or decreasing costs. Much of what has been learned is directly applicable to the newly developing countries.

#### FOOTNOTE

<sup>1</sup>U.S. Weather Bureau, The radar program of the U.S. Weather Bureau, Washington (1961).

#### SELECTED REFERENCES

Barron, E. G., *New Instruments of the Surface Water Branch, USGS, Western Snow Conference, Proc., 28th Annual Meeting* (1960).

This paper describes the electromagnetic and the acoustic velocity meters, the bubble gauge and the surface follower for indicating water levels, the sonic flood-measuring assembly, and the digital water-stage recorder.

Hem, J. D., *Study and Interpretation of the Chemical Characteristics of Natural Water*, U.S. Geological Survey Water-Supply Paper 1473 (1959).

This paper considers: proper sampling; units of measurement in analysis; basic chemistry of constituents and properties determined; application of analysis in hydrologic investigations; and the mineralogic and geologic environment and other factors as they affect quality of water.

U.S. Inter-Agency Report 8, *Measurement of the Sediment Discharge of Streams*, U.S. Army, Corps of Engineers, Iowa City, Ia. (1948).

This report classifies the principles of sediment transport and summarizes the practices most commonly used in carrying out fluvial sediment investigations. Various types of suspended sediment samplers are described, and the practical aspects of selecting sample points and frequency of sampling are discussed.

McCall, J. E., *Stream-Gaging Network in the United States*, Am. Soc. Civil Engineers Proc., 87, no. HY 2, Paper 2776, 79-95, March (1961).

The national stream-gaging program is analyzed and its deficiencies are pin-pointed. A modified program of areal stream gaging is described that would overcome some of these deficiencies.

Ferris, J. G., D. B. Knowles, R. H. Brown, R. W. Stallman, *Theory of Aquifer Tests*, U.S. Geological Survey Water-Supply Paper 1536-E (1962).

The report represents the theory supporting many concepts of fluid movement through porous media, with special reference to testing aquifers to determine their hydraulic characteristics.

Ferris, J. G., A. N. Sayre, *The Quantitative Approach to Ground-Water Investigations*, Econ. Geol., 50th Anniv. 714-747 (1955).

A review of quantitative methods in ground-water hydrology including principles of flow through porous media, mathematical models of flow regimens, analog models, and geologic controls.

Meinzer, O. E., *Outline of Methods for Estimating Ground-Water Supplies*, U.S. Geological Survey Water-Supply Paper 638-C (1932).

An analysis of rock formations as ground-water reservoirs and conduits and methods for evaluating the behaviour of water in such formations.

Skibitzke, H. E., *Electronic Computers as an Aid to the Analysis of Hydrologic Problems*, Inter. Assoc. Scient. Hydrology, Comm. of Subterranean Waters, Publication no. 52, 347-358 (1960).

A description of numerical methods and electric analog computers in their application to problems in ground-water hydrology.

DaCosta, J. A., *Presentation of Hydrologic Data on Maps in the United States of America*, Inter. Assoc. Scient. Hydrology, Comm. of Subterranean Waters, Publication no. 52, 143-186 (1960).

A description of the use of maps for depicting such hydrogeologic parameters as water table and piezo-metric head configuration, ground water flow, aquifer thickness, permeability and storage, and geochemical characteristics.

Langbien, W. B., W. G. Hoyt, *Water Facts for the Nation's Future*, Ronald Press, New York, 288 pp. (1959).

A complete historical review and analysis of U.S. national and state hydrologic data programs, covering all phases of water management and use, with many specific recommendations for improving their scope and efficiency.

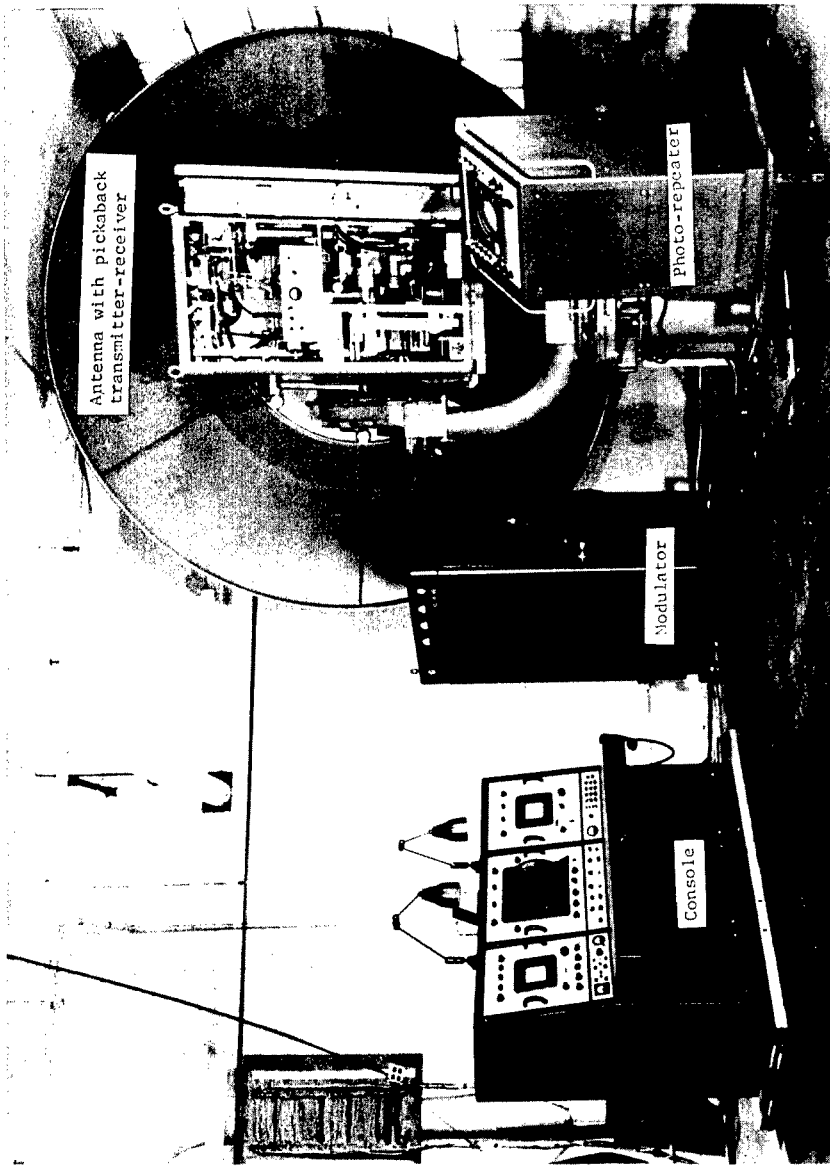

FIGURE I. Major components of the WSR-57 radar.

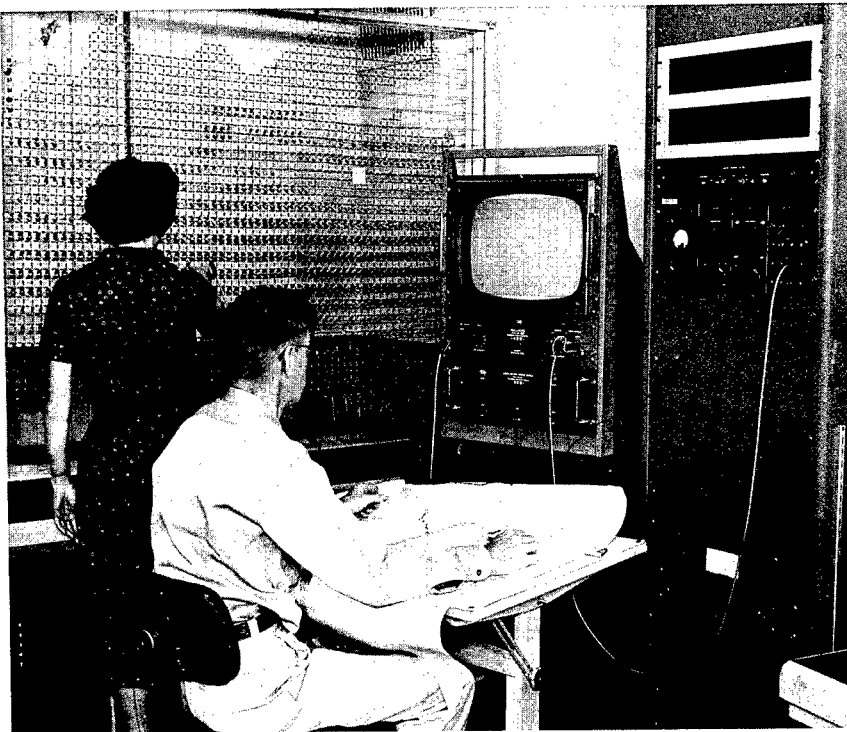

FIGURE II. Passive element analogue model showing oscilloscope, input generator, and resistor-capacitor network of San Simon Basin, Arizona.

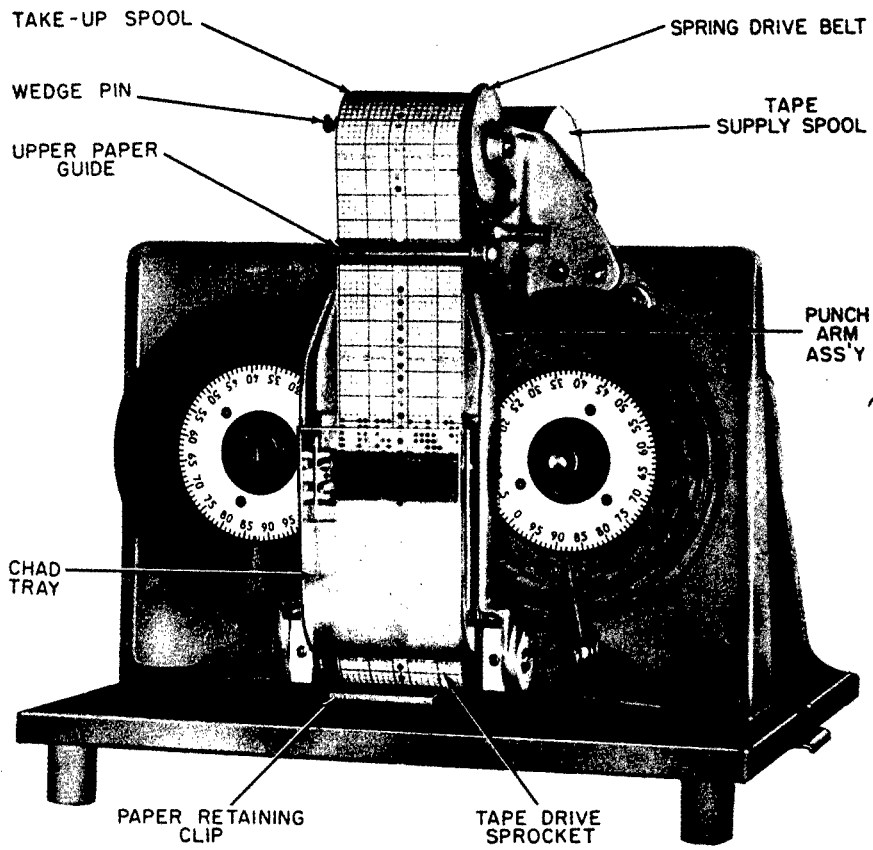

FIGURE III. Digital recorder.

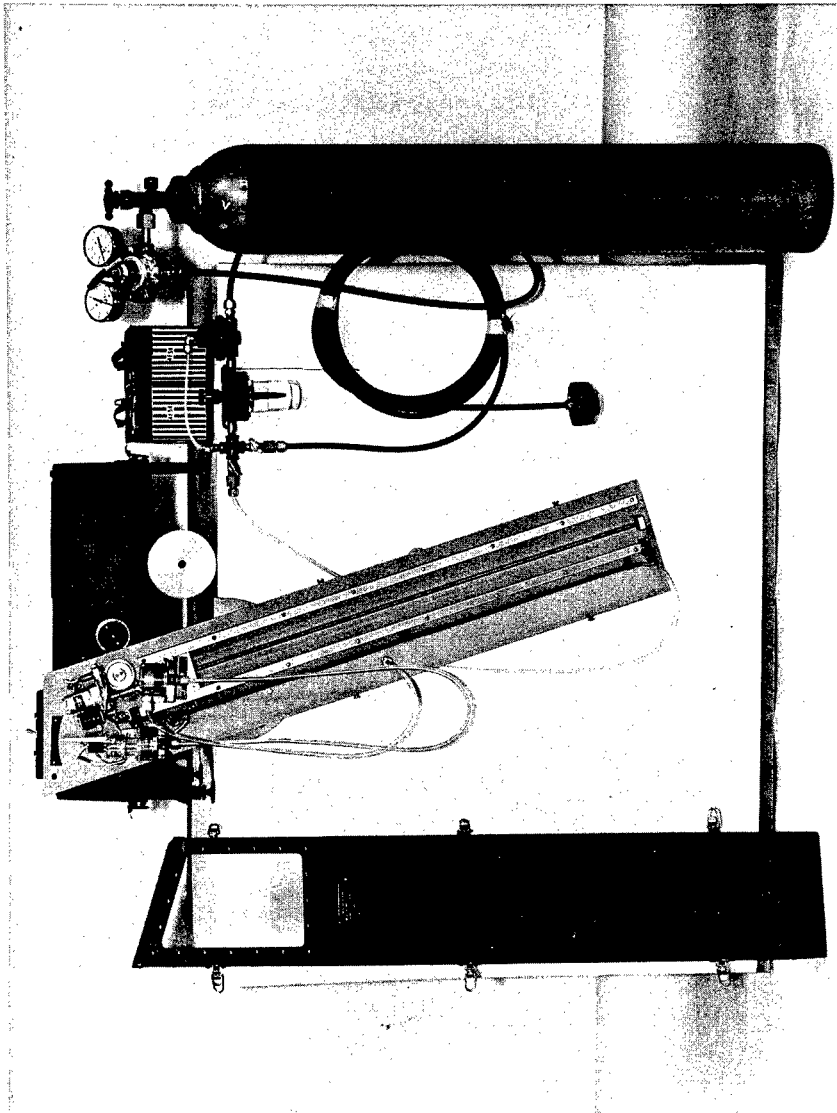

FIGURE IV. Bubble gauge to register river levels.

# Community Water Systems in the United States\*

(Their Protection and Their Impact Upon Health)

ABEL WOLMAN

*Professor Emeritus of Sanitary Engineering and Water Resources,  
The Johns Hopkins University, Baltimore, Maryland*

HERBERT M. BOSCH

*Professor of Environmental Health, University of Minnesota, Minneapolis, Minnesota*

1. A community water system, for the purposes of this discussion, is defined as the integrated delivery of safe water, in ample quantity, into the individual household of every member of the community. It is implied that the provision of this amenity for potable, domestic, and industrial purposes is on an uninterrupted basis 24 hours a day, and 365 days a year. Full pressures on the water mains are likewise presupposed, under the sustained full-time management of a responsible local agency.

2. These detailed specifications are spelled out to distinguish real community systems from those intermittent water services, of sometimes safe quality, delivered at points remote from the user and at pressures often reduced to zero. Even these latter inadequate services are now only sparingly available to somewhat more than two-thirds of the population of the world. In retrospect, however, they

represent a reasonable picture of the domestic water supply situation in the United States some 100 years ago. It is valuable, therefore, to retrace the history of community water development in this country, in order to determine the means by which this gap has been largely closed and to measure the impact which this development has had upon the public health and upon society in general. Not always were the people afforded this universal necessity and luxury for safeguarding life and cleanliness. Some of the lessons of the past, therefore, have important implications for accelerating the installation of water facilities throughout the globe.

## **The History of Community Water Expansion in the United States**

3. The earliest public water supplies date from 1652 at Boston, Massachusetts, about 1732 at Schaefferstown, Pennsylvania, and at Bethlehem, Pennsylvania,

\*U.N. Conference paper.

in 1761. At the close of 1800, only 17 water works were in operation. The number did not pass the hundred mark until 1850 and the thousand mark until 1885. By 1895, the figure had reached about 3,000. At the close of 1924, it is estimated that over 9,000 water works were supplying about 10,000 communities.

4. The turn of the faucet was by then all that was necessary for thousands of people to secure either hot or cold water on any floor of a dwelling. The public water supply was already having its impact upon public health, the protection of life and property against fire, street sprinkling, sewer flushing, and many industrial uses. These supplies were not only substituting safe for unsafe drinking water, but were also making water carriage sewerage systems possible, which in turn were abolishing the dangerous privy and cesspool.

5. The evolution of the systems under private sponsorship is of interest, particularly in view of the fact that, outside of the United States and much of the European areas, private ownership of community water systems is frowned upon and often prohibited. Yet in 1890, in the United States, with 23 million people supplied, one in three systems was privately owned and operated. By 1925 over 85 percent of the people were provided by municipally owned water works. Although this ratio had been materially altered by 1960, it is still true that approximately 20 percent of the people are served by privately owned systems. Private capital may have an honorable place in many countries in the development of new water systems, provided governmental policy and "climate" are favorable.

6. By 1900, about 30 million people had the advantages of a municipal water

supply, with a use of some 3 billion gallons a day. In 1954, these figures had grown to over 100 million people, with a daily total use of some 16 billion gallons. The average use per person per day, for the country as a whole was approximately 150 gallons.

7. Today, some 21 thousand communities, serviced by some 18 thousand systems, provide approximately 135 million people with water facilities as earlier defined.

8. The continuing rapid urbanization and industrialization of the United States gives no basis for assuming that the provision of new water facilities is at an end or, in fact, may even be tapering off. On the contrary, all projections for the future show major increases in population and continued marches toward the urban areas. It is probable, therefore, that total demands by 1980 will reach at least 29 billion and by 2000 at least 43 billion gallons per day. Even the per capita daily uses will rise with the increase of the standard of living, and the wider use of water requiring household equipment, such as the automatic clothes washers.

### **The Cost of Facilities**

9. Because of the long history of community water development in the United States no truly reliable estimate is available of the total investment in these facilities. It may be assumed, however, that it exceeds, for the complete systems, some \$17 billion. In the year 1958 alone, the capital expenditures reached almost \$850 million.

10. Of much greater significance than these astronomical figures is the transcendent fact that unit costs or per capita

annual costs are surprisingly and modestly low. This salient fact needs to be emphasized and re-emphasized in applying the lessons of U.S. experience to the solution of this important problem in developing countries. In these regions, the staggering capital investments required frighten the ministers of finance, of public health, and of public works. Yet, the strengthening of borrowing power, the development of the principle of reimbursability, the fortifying of local responsibility in management and fiscal control, all change the emphasis in time from capital investment figures to annual costs per person. These latter amounts are not intimidating and are increasingly within the grasp of millions of people, when the realities of sound financing appear on the horizon.

11. The case history of the United States is again full of confirmation of these generalizations. For example, in 1954, the latest year for verifiable data, the average annual cost for water per person was \$9.79, with a high in the arid Great Basin region of \$13.67 and a low in the humid Chesapeake Bay region of only \$7.97. Even with the great developments for community water projected for 1980 and 2000, involving billions of dollars of capital expenditure, the annual costs will remain \$10 or less per person, on the average. These annual costs include operation, maintenance, interest, and amortization.

12. Safe water delivered into the house is a remarkably cheap and plentiful commodity. It generally costs from 5 and 10 cents a ton. No limit should be placed on the amount furnished or the time at which it is available, provided it is not wasted or dissipated uselessly and the customer pays for it.

13. In general, these criteria have been the guiding ones in this country and increasingly they are being more fully met. Of equal importance, however, is the realization that this amenity has been universalized among urban dwellers almost entirely through local responsibility and local financing and repayment. So successful has this performance been for over 100 years, that water works bonds are rated among the highest priorities of safety in the open financial market. Defaults have been rare, interest rates often are less than 6 percent and frequently less than 4 percent annually, and periods of repayment in general extend to as much as 40 years.

14. These situations are evolutionary. They have not always been so. They reflect at least half a century of local responsibility and integrity, and a climate of political stability. Without them, public water systems will be slow in creation and non-generative in character. Central government subsidy, external largesse, in any form of gift, rarely provide the above necessary ingredients. The major lesson of the United States experience is that the present 18 thousand systems are predominantly the result of local financing, without any significant central government subsidy.

### **The Search for Pure Water**

15. Man has pursued the quest for "pure" water for thousands of years. The criteria for purity have become, during these centuries, more complex, more quantitative, and increasingly more rigid. The search, of course, is never ending, because the world is not static, technology is ever on the move, populations and their consequent waste products

eternally increase, and because the consumer protection requires more and more complex controls. Centuries ago primary desires were to avoid or treat turbid waters. As a matter of fact, the treatment of the earliest supplies in this country centered on the removal of mud, while the original reason for a public water supply in many instances was solely to lay the dust on unpaved dirt streets and highways.

16. The disease hazards of water, although empirically suspected in earlier years, were not the major motivations toward community systems. The chemical test long preceded the great progress of control in the biological era. To these have now been added the diagnostic indices for more exotic organic and inorganic substances in water, whose physiological effects are still but dimly understood. Accompanying all of these throughout the last century has been the everincreasing demand by the consumer, often running ahead of the technologist, for esthetic perfections of superior palatability. Today, the water must be tailor-made, not just grossly liquid.

17. These advances in desire were naturally initiated by the forward march of water purification methods, closely followed by sewage-treatment processes to guard and improve the surface- and ground-water sources of the community systems. The great progress in these installations, it must be again remembered, was made only over the last century.

18. Until 1870 no water-filtration plants existed in the United States. Some so-called filters or strainers were in use, but they could not be dignified by listing as filters are now understood. In the 1870's the Poughkeepsie and Hud-

son, N.Y. slow sand filters were built, followed by those at Lawrence, Mass. in 1893. In the late 80's, the earliest rapid sand units appeared. By 1897, over one hundred of such installations had been built, and by 1925 about 587 rapid and 47 slow sand filters were already in use. They were delivering approximately 5 billion gallons per day.

19. At the turn of the 20th century, the great additional jump forward in water protection came about in the introduction, in 1908, of the use of chlorine for bacterial disinfection. Chlorination subsequently became the universal beneficial "vade mecum" of the sanitarian, both in water and in sewage treatment.

20. Installations for water treatment have proceeded at a high rate from 1925 to date. Simultaneously, however, sources of water have become increasingly polluted by familiar biological and chemical materials, reinforced by newer and less familiar types of industrial and other wastes, such as synthetic organic chemicals and radioactive materials. Many viruses and other disease-producing organisms add to the ever-growing control problems.

21. In spite of the delays due to economic depressions and wars, progress in pollution abatement has been great in the last 40 years. By 1957, over 75 hundred sewage treatment plants had been serving some 77 million people. An additional 22 million had sewerage at that time, although their 3 thousand communities were discharging raw sewage. The sewered population covered somewhat less than 100 million people in over 11 thousand communities.

22. The tabulation which follows places these accomplishments in chronological perspective: (in millions)

Year	Urban population	Sewered population
1900.....	30	25
1920.....	54	50
1940.....	80	70
1960.....	126	105
1980.....	<sup>1</sup> 200	<sup>1</sup> 200

<sup>1</sup> Estimated.

23. The sewage-pollution abatement picture, however, still remains less than satisfactory, even though U.S. cities spent more money in 1961, for this purpose, than ever before in history. On January 1, 1962, some 5,290 communities still had inadequate or no sewage treatment facilities. Their impact on drinking-water quality, however, should not be exaggerated, since water-treatment processes have been singularly effective. In addition, less than 4 percent of the 5,290 communities encompassed more than 5 thousand people apiece.

24. The expenditures in 1961 for sewage treatment were approximately \$560 million. Federal funds were represented in this amount to the extent of \$1 of Federal money to every \$5.50 of local municipality money. In prior years, by far the largest expenditure had its origin locally, unsupported by central government subsidy. For the future, the projected annual costs (operation, maintenance and amortization of investment) for collection and treatment will be \$818 million for 1980 and \$1,200 million for 2000. The projected annual costs per person are again extremely modest, namely, less than \$5 in 1980 or 2000.

### The Impact Upon Public Health

25. Impure water has always been a carrier of disease. Contamination of

water courses, surface or underground, has been the rule wherever there were people. The wastes of man have invariably been indiscriminately distributed in his environment. Since man has been the host of many diseases and many of these have spent part of their life cycle in the digestive tract, their causative organisms have found their way into human urinary and fecal discharges. The number and variety of these organisms have been myriad. They run the gamut from the ubiquitous typhoid fevers, amebic dysenteries, infectious hepatitis, schistosomiasis, and others too long to enumerate.

26. All these diseases, not too long ago, plagued this country. All are in part water-borne. Today, many of these diseases are relegated to the classification of "tropical." This designation, however, is truly a misnomer, since these so-called "tropical" diseases at one time were universally distributed, in cold as well as hot climates. They have not, in fact, disappeared from the Western World, but have been banished and controlled by environmental sanitary measures, such as water purification. When these measures are relaxed, the diseases recur.

27. In most developing countries, many of which are tropical, these sanitary restraints have not yet come into play on any large scale. Until they do, the enteric diseases will continue to take a major toll in disability and in lives.

28. The major lesson of the advent of community water for all the people in the United States is in the great accompanying reduction in the enteric diseases of water-borne character. Typhoid fever disappearance is a striking example of this accomplishment. This experience

gives equal promise to other evolving countries. A brief review of its history in this country is pertinent, because it represents one of the most remarkable public health achievements since the turn of the 20th Century.

29. The typhoid fever deaths per 100 thousand in 1900 were 35.8. By 1936 it had been brought down to 2.5, while today it is virtually zero (figure I). Minor recrudescences occur, but it is rare to see a typhoid case in an American hospital. Of equal significance is the fact that in the large cities, say over 100 thousand, the rates have consistently been notably lower than those for the Nation as a whole. Safety of water, coupled with pasteurized milk, has undoubtedly accounted for this prideful accomplishment. It can and should be matched in the next decades in the developing countries.

30. The role of water quality in the dissemination of enteric diseases, of course, had been recognized for a number of years. Even before the bacteriological era (1854), Snow in England had shown the relation between water from the Broad Street pump in London and an epidemic of cholera, in his classic monograph *Mode of Communication of Cholera*. That pathogens causing the diarrheal diseases of children, typhoid fever, cholera, and shigellosis can survive in water and can cause illness to those who ingest the water is well-known. In more recent years the possible role of water in the transmission of infectious hepatitis has also been studied. Because of its comparative universality, typhoid fever morbidity and mortality data have been used as criteria of water sanitation, despite the fact that water is not the only mode of transmission of that disease. The increase in the number of municipal

water supplies has paralleled closely the decline in typhoid deaths for over half a century. Undoubtedly, continuous disinfection of public water supplies with chlorine accelerated this decrease of water-borne typhoid fever. A very considerable decrease of water-borne typhoid occurred, however, even before the disinfection with chlorine became a common practice. This would seem to indicate that the installation of community water supplies, even though not all of the highest sanitary quality, may be expected to have an appreciable effect on typhoid fever death rates.

31. The annual reports of the Massachusetts State Board of Health prior to 1900 yield considerable evidence on the value of public water supplies in reducing typhoid fever, even before chlorination was adopted. Very early the Massachusetts Department of Health recognized the relationship between community water supplies and typhoid fever incidence. That department was the first State health department in the United States. It early assumed an active role in the promotion of community water supplies and investigation of the effect of such water supplies on the public health. The growth of water supplies and the corresponding typhoid fever death rates in the State is shown in figure II. The following extract from a letter by Mr. Hiram F. Mills, engineer chairman of the Committee on Water Supply of the Massachusetts State Board of Health, is of interest, since the data reported refer to the era before chlorination or other methods of disinfection of public water supplies were in use.<sup>1</sup>

32. (a) "More than one-half of the cities of the State had public water sup-

plies introduced within the years from 1869 to 1877. In the table below are given the number of deaths from typhoid fever yearly in 10 thousand inhabitants,

in each of the cities introducing water in the above period, for the ten years previous to the period and for the twelve years following it: <sup>2</sup>

	Yearly no. of deaths by typhoid fever per 10,000 1859-1868	Date of introduction of water supply	Yearly no. of deaths by typhoid fever per 10,000 1878-1889	Percentage deaths in the latter period are of those in the former
Holyoke.....	6.73	1873	8.93	133
Lawrence.....	8.34	1875	8.33	100
Lowell.....	6.16	1872	7.63	124
Fall River.....	7.78	1874	6.32	81
Springfield.....	9.67	1875	5.29	55
Taunton.....	6.12	1876	5.02	82
Northampton.....	10.98	1871	4.04	37
Lynn.....	9.06	1871	3.87	43
New Bedford.....	7.77	1869	3.80	49
Newton.....	6.57	1876	3.65	56
Malden.....	8.04	1870	3.54	44
Fitchburg.....	10.59	1872	3.16	30
Woburn.....	8.29	1873	2.95	36
Somerville.....	4.28	1867	2.95	69
Chelsea.....	5.97	1867	2.89	48
Waltham.....	8.12	1873	2.42	30

(b) "Of these 16 cities all but 3 had less typhoid fever after introducing public water supplies than before; and their average number of deaths from this cause was less than one-half of the number of deaths when they used water from wells." (It is assumed that the word "wells" in the preceding sentence refers to individual household wells.)

33. In the case of typhoid fever and cholera, the principal involvement of the water supply is in connection with water which is ingested through the mouth. In the case of shigellosis and some of the infant diarrheas, there is increasing reason to believe that the availability of water supply in ample quantities may be equally or even more important than the bacteriological quality of the supply. In

a well-controlled study, Hollister et al. have reported on the influence of water availability on shigella prevalence in children of farm-labor families in the State of California, USA. Their studies confirm the impression of Watt who had postulated that water, even though it might be "below standard," could act as a diluent and assist in the reduction of intestinal infection when used for personal hygiene purposes. Hollister and his colleagues compared the shigella positivity rates between camps which had cabins equipped with inside water faucets and camps which had a portion or all of the cabins with outside water faucets. Their data are shown in figure III.

34. Wagner and Lanoix comment on a study carried on in Palmares, State of

Pernambuco, Brazil, by the Servicio Especial de Saúde Pública. This Brazilian study showed that there probably was a relation between the availability of water supplies and the deaths from diarrhea of young infants. The study also gave some indication that the health risk was about the same whether the treated water was carried from public fountains to private houses or whether water was taken from open unprotected "wells."

35. The record of the impact of water supply upon disease in the United States gives no basis for assuming that control and eternal vigilance may be dispensed with, once water systems are provided. We have a long history of recurring water-borne disease when such vigilance has been relaxed. Unfortunately, the disappearing enteric diseases do lead to the impression that water-borne epidemics are no longer to be feared as they were in the past. Those who hold this viewpoint must take heed of the toll exacted by these diseases since 1920, even though the total picture has been amazingly good.

36. It was in this period since 1920 that the largest water-borne amebic dysentery epidemics occurred in Chicago in 1933 and 1934; bacillary dysenteries and typhoid in California and New York in 1936; jaundice in Kansas and other American schools in 1935 and subsequently.

37. As if by way of reminder of the ever-present water-borne menace, the typhoid epidemic in 1959 at Keene, New Hampshire, offers a truly classical example of inadequate supervision and the absence of chlorination. A rare set of circumstances, as is always the case, produced illness of epidemic proportions—namely, a carrier on the watershed, torrential rains and a filter plant failure.

It is well to be reminded that operating personnel, although conscientious, are subject to error and that facilities can and do fail.

38. Perhaps one of the stimulating forces in the rapid development of purification lay in the attitude of the courts in the award of damages against private and public corporations found responsible for illness resulting from pollution of water supplies. In several instances the damages were high, as in the case of Olean, N.Y., where the city had to issue bonds to the extent of \$350,000 to pay the costs incurred in a water-borne typhoid fever epidemic of 1929. Keene, already referred to, also paid damages aggregating thousands of dollars. An incomplete listing now accounts for such payments in somewhat over two dozen instances.

39. A somewhat different beneficial resultant of water adjustment is now apparent in the addition, artificially or naturally, of fluorine to public water supplies. Something of the order of 1 ppm of Fl in water, it has now been demonstrated, results in a major reduction of dental caries in children and adolescents. The helpful effects on older persons are measurable, but less. Disabilities in well-controlled application to water have been shown to be negligible. The courts have generally sustained the validity of such practices.

40. In 1945, the population supplied with fluoridated water was 231,920 in three communities. In 1959, the number so served had risen to 36,199,047 in 1109 communities. In addition to these supplies with controlled fluoride addition, 7 million people were using waters naturally contained at least 0.7 ppm Fl. The total population protected, therefore, was 43 million.

## Global Implications

41. Recently, Dr. Abraham Horwitz, the Director of the Pan American Health Organization, speaking from his experience in his native Chile and from the results of his programs in North America, Central America, and South America, made the following statement:

"If a single program were chosen which would have the maximum health benefits, which would rapidly stimulate social and economic development, and which would materially improve the standard of living of people, that program would be water supply with provision for running into or adjacent to the house."

42. Despite the deficiencies in the reporting of enteric diseases in many developing countries, it is clear in all of them that the mortality from typhoid fever, gastritis, enteritis, etc., is excessively high. It ranges in the figures prevailing in North America in the last period of the 19th Century. As a matter of fact, for all age groups and particularly for infants and children 1-4 years of age, the diarrheal diseases rank either first or in the first five of the principal causes of disability and death.

43. As Dr. Horwitz points out, and as is generally accepted by most health officials, a major reduction in these diseases is possible, quite independent of etiologic and sociologic differences in countries or regions, by the provision of potable water in sufficient quantities to keep clean and conveniently accessible to people. In such programming, safe water for the thirsty is not the sole objective and greater quantities of water must be provided for all the other amenities of cleanliness and urban living.

44. The situations in two regions of the world may illustrate both the public health need and the deficiencies in community water service. In the Central and South Americas, the deaths from the enteric diseases are still higher, in some countries, than 2 hundred per 100 thousand, and figures in excess of a hundred per 100 thousand are common. Of the 16 countries of Latin America, in the age group 1 to 4 years, diarrheal diseases were the leading cause of death in 11 and among the first five principal causes in the remaining five. These facts are graphically demonstrated in figure IV.

45. Using water service as hitherto defined, the availability of water in the Americas is sadly deficient. Out of 75 million people in cities of more than 2 thousand population, 29 million are without such service. Almost 50 percent of the people in cities of 10 thousand to 50 thousand are in the same deficient category. More than 70 percent are without service in cities of 2 thousand to 10 thousand. In rural areas, matters are even worse. Of these 107 million people, far more than 70 percent are without water service.

46. The leaders of these countries are of course well-aware of these deficiencies and of the snail's pace in their correction. This understanding is well reflected in the Charter of Punta del Este which calls for the provision of adequate water supply, sewerage and excreta disposal, in the next 10 years, for at least 70 percent of the urban and 50 percent of the rural population. To accomplish this sound purpose will require strong support for the prompt and continuing adoption of the fiscal, engineering, and managerial principles which have resulted in the great progress in the United States.

47. In another part of the globe, India, similar disease and water deficiencies confront the policy maker. The issues are the same as previously discussed. They are well-recognized. Impatience with the slow pace of community water development over the last 20 years drives this country toward the realization that a new look, at an old problem, is demanded.

48. Such a new look in India was completed in 1961 by a special committee created by the Ministry of Health, Government of India, by an order dated April 28, 1960. The inquiry resulted in conclusions and recommendations issued in 1962 by the Committee on National Water Supply and Sanitation. Its findings warrant brief restatement here in abbreviated form:

(a) For the urban population of 78 million, about 34 percent were judged as adequately served with water, 26 percent inadequately, and 40 percent not served.

(b) For the same urban population, adequate sewerage service was available for 21 percent and no service for 68 percent.

(c) In the rural areas, defined by the Committee as encompassing some 300 million people, progress on individual well installations aggregating

over 500 thousand in number is significant, but unsatisfactorily slow.

49. The closing of these sanitary gaps in India, it is recognized officially, will require "a new path to be cut if the program is to succeed and move on its own momentum. Local bodies should be encouraged to promote urban water supply and sewerage schemes as a self-paying industry, just as electricity undertakings are promoted and operated. The method of financing of such schemes should be patterned after the procedure and practice which have succeeded and established themselves in the more advanced countries, with such modifications as are dictated by conditions in this country."

50. The conclusions to be garnered from the experience in the United States and to be rapidly applied in the emerging countries of the world are well stated in the India Report, in the following terms:

"The Panel has therefore no misgivings on the outcome of such a venture if pursued vigorously by all the States. A certain amount of initial education and leadership would be necessary in order to wean the urban citizen and the local body from their established conventional notions that drinking water should be provided as a partial gift by the Government."

#### FOOTNOTES

<sup>1</sup> Twenty-second Annual Report, State Board of Health of Massachusetts, 1890. pp. 234-5.

<sup>2</sup> Note that the rates are per 10 thousand rather than per 100 thousand population.

#### SELECTED REFERENCES

*Water Works Practice*, Manual, The American Water Works Association, The Williams and Wilkins Company, Baltimore (1926).

Baker, M. N., *The Quest for Pure Water*, The American Water Works Association, Inc., New York (1948).

*Future Water Requirements for Municipal Use*, U.S. Public Health Service, Committee Print 7, Select Committee on National Water Resources, U.S. Senate, December, 1960, Government Printing Office, Washington (1961).

*Pollution Abatement*, U.S. Public Health Service, Committee Print 9, Select Committee on National Water Resources, U.S. Senate, December, 1960, Government Printing Office, Washington (1961).

Hollis, M. D., *The Water Pollution Problem*, Proceedings of the National Conference on Water Pollution, U.S. Public Health Service, December, 1960, Washington.

Wolman, A., Arthur E. Gorman, *The Significance of Waterborne Typhoid Fever Outbreaks, 1920-1930*, The Williams and Wilkins Company, Baltimore (1931).

Gorman, A. E., Abel Wolman, *Water-borne Outbreaks in the United States and Canada and Their Significance*, The American Water Works Association, New York (1939).

State Board of Health of Massachusetts, *First to Twenty-Ninth Annual Reports*, Boston (1869-1899).

Hollister, A. C., Jr., M. D. Beck, A. M. Gittelsohn, E. C. Hemphill, *Influence of Water Availability on Shigella Prevalence in Children of Farm Labor Families*, American Journal of Public Health, 45, 354-362 (March, 1955).

Watt, J., A. C. Hollister, Jr., M. D. Beck, E. C. Hemphill, American Journal of Public Health, 43, 728-741 (1953).

Wagner, E. G., J. N. Lanoix, *Water Supplies for Rural Areas and Small Communities*, World Health Organization, Monograph Number 42, Geneva (1959).

Healy, W. A., Richard P. Grossman, *Water-Borne Typhoid Epidemic at Keene*, New Hampshire, Journal of the New England Water Works Association, 75, 1, 38-52 (March, 1961).

*Status of Fluoridation in the United States and Canada, 1959*, Task Group Report, Journal of the American Water Works Association, 52, 12, 1513 (December, 1961).

Horwitz, A., *Facts in Health Problems*, Pan American Health Organization, Washington (July, 1961).

Wolman, A., *Technical, Financial, and Administrative Aspects of Water Supply in the Urban Environment in the Americas*, Boletín de la Oficina Sanitaria Panamericana, XLVII (5 November, 1959).

*Report of the National Water Supply and Sanitation Committee*, Ministry of Health, Government of India, New Delhi (1960-1961).

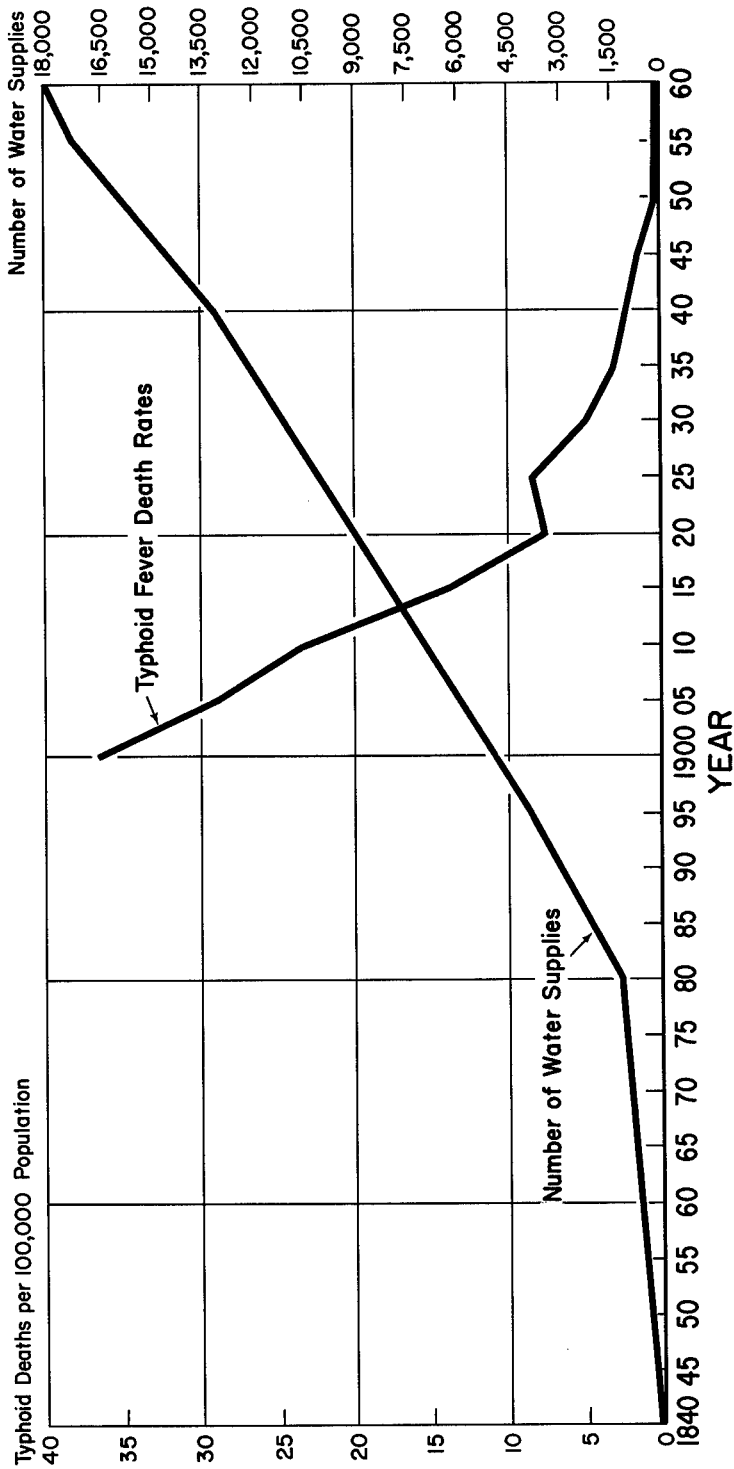

FIGURE I. Water supplies in the United States of America and typhoid fever death rates in the United States registration area (from the United States Census Bureau Reports).

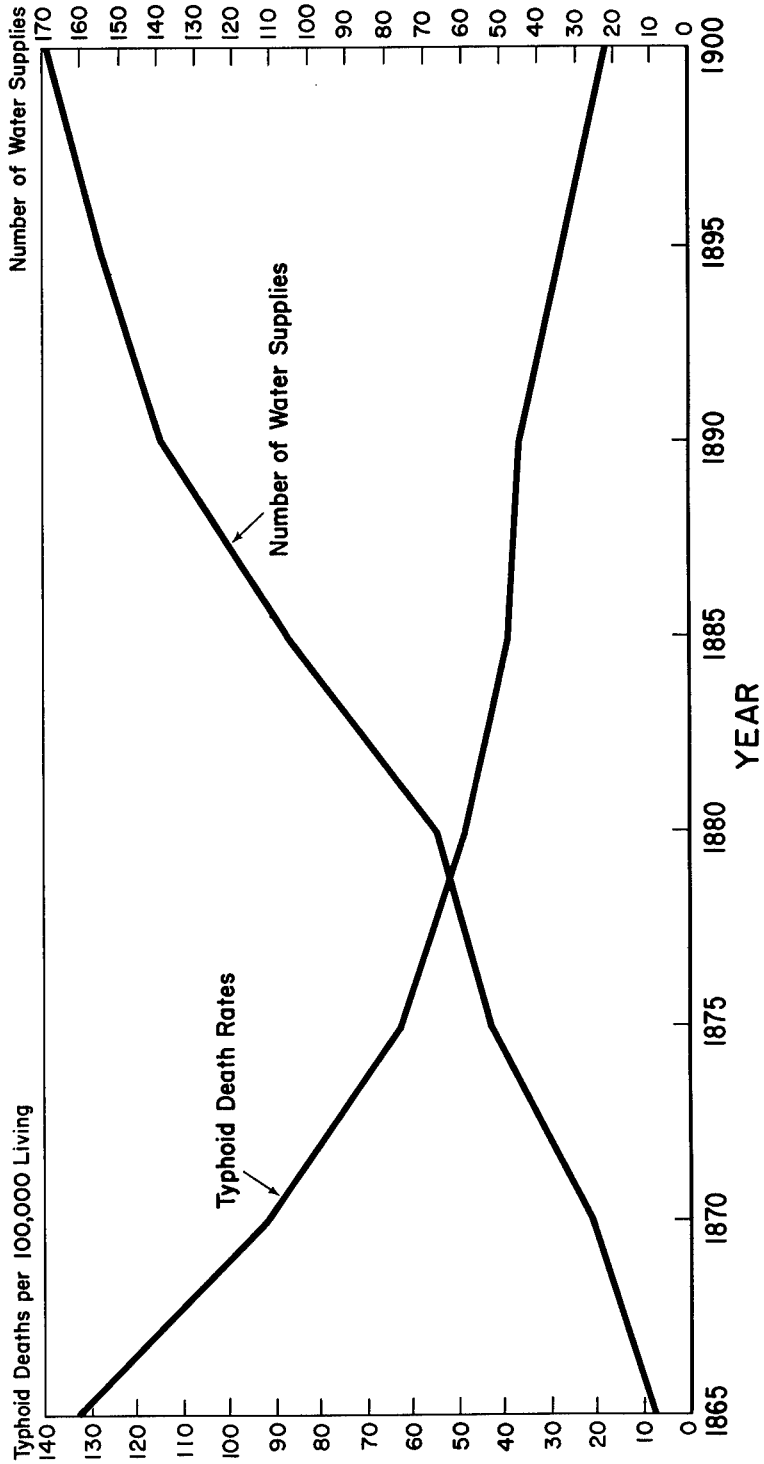
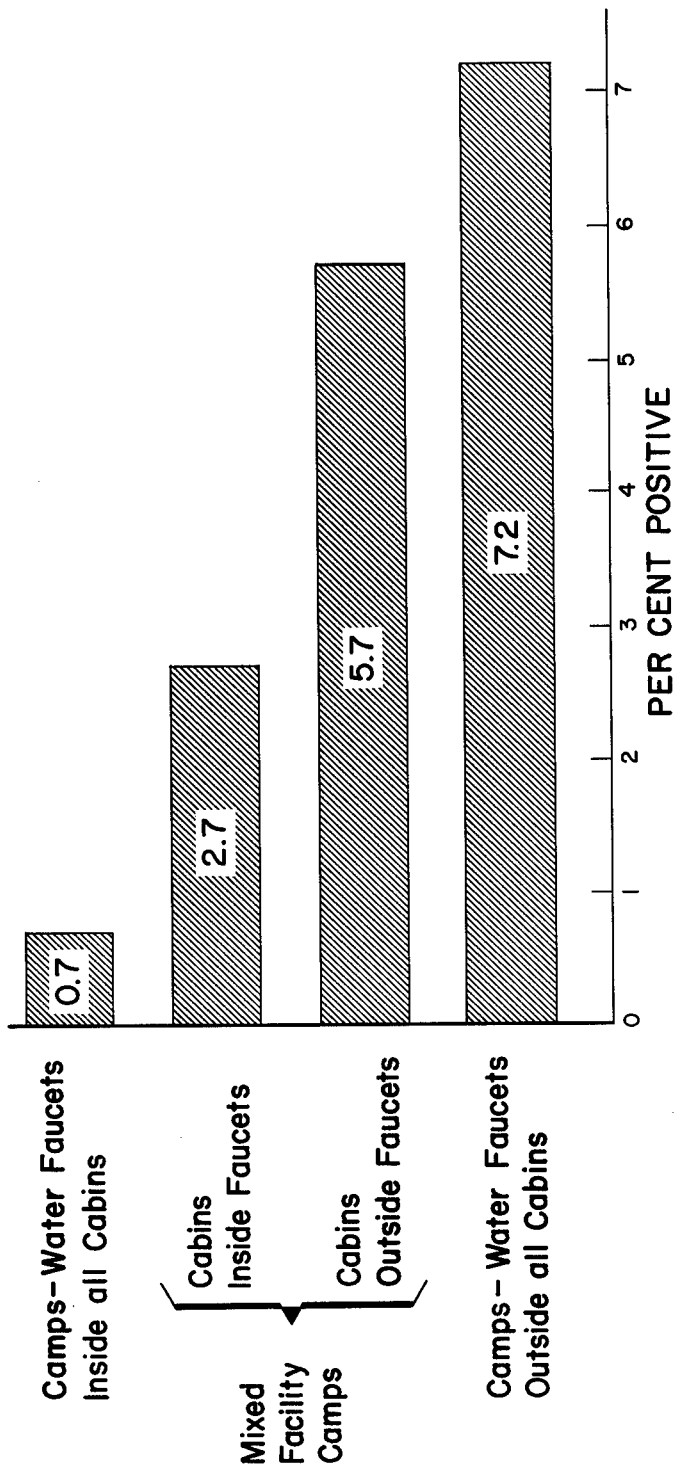

FIGURE II. Water supplies and typhoid death rates for the State of Massachusetts, 1865-1900.



Source: Hollister, A.C.; Beck, M.D.; Gittelsohn, A.M.; and Hemphill, E.C. Influence of Water Availability on Shigella Prevalence in Children of Farm Labor Families, A.J.P.H., 45: 361 March 1955

FIGURE III. Shigella positivity rates by water availability in farm labor camps, Fresno County, California, 1952-1953.

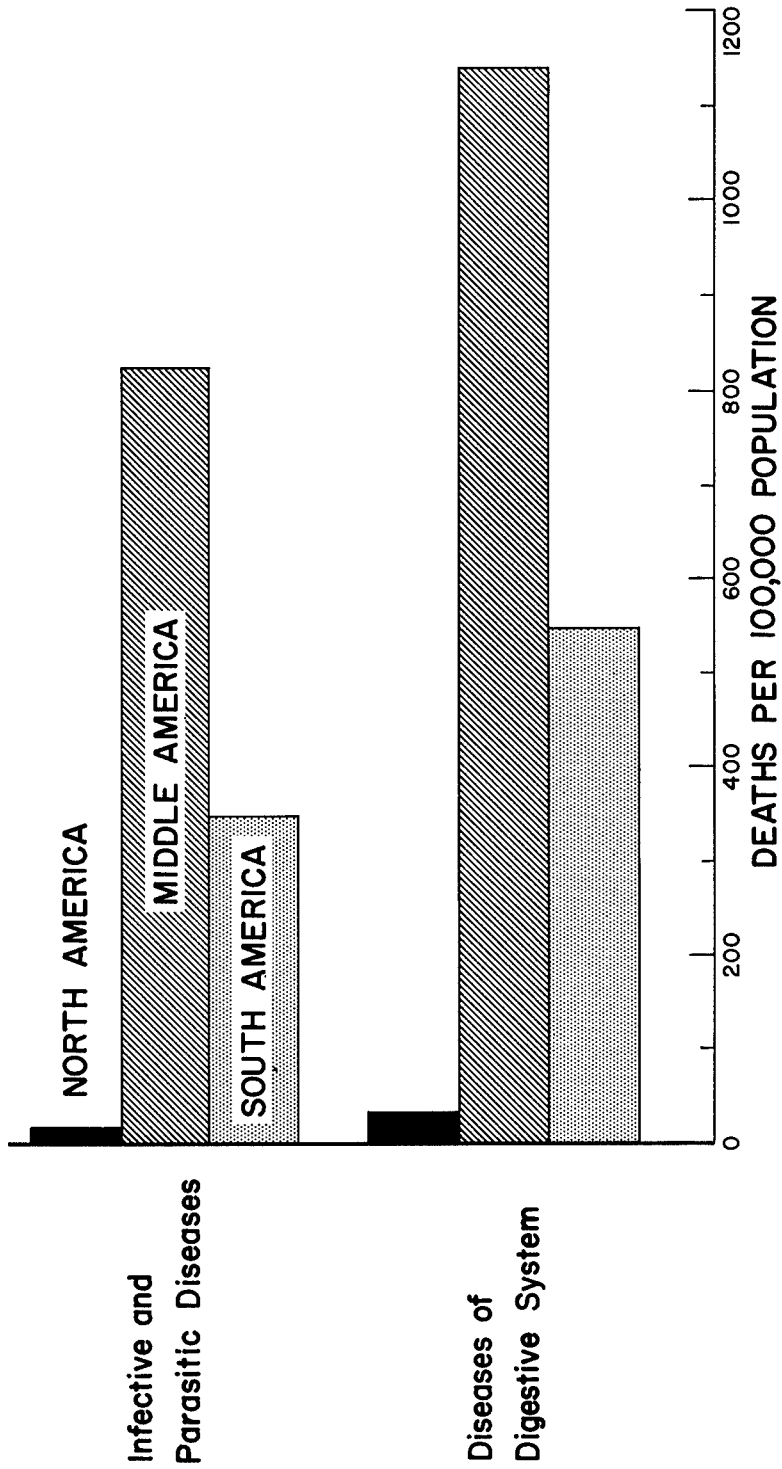

FIGURE IV. Deaths of children under 5 years of age per 100,000 population by groups of causes in the three regions of the Americas, 1956.

# The Community Water Supply Development Program of the Agency for International Development

A. DALE SWISHER

*Sanitary Engineer, U.S. Agency for International Development, Washington, D.C.*

1. To millions of people in thousands of communities throughout the world, a better way of life means WATER—clean, sparkling, potable water—all the water they need, when and where they need it. Today, piped water in the home is still a dream to the major part of the world's population. Tomorrow—the decades of the sixties and seventies—may well see the dream gradually realized through a number of special cooperative efforts now under way among nations such as those of the World Health Organization, and of the Community Water Supply Development Program (CWSDP) of the Agency for International Development (AID).

2. The latter program—the subject of this account—touches water supply activity in 42 countries, with consequent health benefits and large significance for general economic and social progress. The types of activity fostered are adapted to the circumstances of particular countries, as, indeed, they must be.

## Background of the Program

3. The design of the AID program, and of the specific steps which give it its

character, naturally did not come about overnight. Some of the relevant experience reaches back 20 years to agreements among the nations of the Western Hemisphere, in particular to bilateral health programs set up by 21 Latin American republics and the United States in Rio de Janeiro in 1942.

4. It was early recognized that a major cause of debility and illness is that group of diseases commonly transmitted through impure water. These include a variety of diarrheal and dysenteric diseases and a group of virus diseases including infectious hepatitis and poliomyelitis. A potable water supply is not only a key element in the control of these diseases but the ready availability of water contributes substantially to the reduction of scabies, lice, and filth disease. Consequently, from their inception, water supply has had a prominent position in earlier cooperative health programs and in U.S. foreign assistance generally. A first step in various countries often was the setting-up of cooperative agencies as part of certain ministries at the invitation of the host government. Programs were generally carried out on the basis of individual projects—in public

health, for instance, the building up of a department of environmental sanitation or of sanitary engineering; the design, construction and operation of water systems, of health centers, and other health facilities.

5. In the 1950's, it became evident that cooperative aid programs should be concerned with basic conditions of economic growth as well as assistance in public health and in technical fields. Individual farmers might learn to use fertilizer and better seed, but their efforts could be handicapped by poor farm-to-market roads. Health practices could be taught, but would be nullified by lack of sanitary water supply and sewage disposal systems.

6. As the concept of technical aid broadened into development assistance, interest in promoting community water supplies continued as strong—if not stronger—than in earlier years. For it was seen that community water systems can be a major factor in social and economic development. A water system—a tangible demonstration of accomplishment—is essential to economic progress. Only a healthy citizenry can effectively reach toward its potential; and safe water, free of the infective agents of a dozen different diseases, is mandatory if people are to be able to do that, and to benefit from a higher living standard. Further, many of the needs of industry for water supplies are usually met through community or public systems. In developing countries reliable water-supply service can play an important part in stimulating and supporting the development of industry. Another mandate for water-supply development is that issued by the tourist. Tourists are often regarded as capricious and luxury-loving, but they are willing to pay and sometimes

are a major source of foreign exchange. The beautiful and hospitable Republic of San Marino is an example. This small country is host each year to 1.6 million visitors; the revenue therefrom is an extraordinary portion of the Government budget. In 1958, it was realized that hotels and restaurants with restricted water supplies entice few tourists to prolonged visits. The water supply has now been doubled and the Republic confidently expects even more visitors. Finally, a good community water supply may be a strong influence in fostering civic pride and improvements.

7. The success of the pioneer efforts of the predecessor agencies of AID is attested by a number of events in 1957, 1958, and 1959. In 1957 the Inter-American Committee of Presidential Representatives proposed a water-supply program for the Western Hemisphere. In 1958 the U.S. Public Health Service recommended that a community water-supply program be undertaken on a global basis. In 1959 the Director-General of the World Health Organization proposed, and the Twelfth General Assembly endorsed, a global program. Today, AID, WHO, and the Pan American Health Organization (an autonomous agency which also serves as the Regional Office of WHO) collaborate in carrying out water supply programs by exchanging information and experience and by joint sponsorship of certain activities. Specific instances of cooperation and coordination are mentioned later.

### The Program and Its Objectives

8. The CWSDP program was set up on its present lines in 1959, with less emphasis than in earlier years on design and construction of individual projects,

and more on matters of planning, training, operation and maintenance, management of systems, and research.

9. The program's overall objective is to assist cooperating countries to help their citizens provide themselves with safe, reliable, good quality water, through systems that are self-supporting. To this end, the CWSDP assists countries to: define or establish a national agency legally responsible for design, construction, and competent operation of community water supplies; complete basic engineering and economic studies prerequisite to detailed design and construction; improve and expand the managerial and operational capabilities of water works personnel.

10. For many countries, the immediate task is to define the water-supply problem, to assess it properly. This requires a national organization endowed with the necessary responsibility and authority, equipped with a competent administrative and technical staff. The organization will analyze the water-supply needs, set both long-range and intermediate goals, and determine the available resources—activities which form the basis of a national plan.

11. With the emergence of a national plan will come the realization that proposed solutions will require money, large sums of money, perhaps more than apparently available. Few, if any, nations have adequate funds in the national treasury to construct, operate, maintain, and expand all the water-supply facilities desired. It is usual at this point to seek external financial assistance. Such assistance is invaluable, but close consideration inevitably produces the realization that the long-term solution rests with the community itself. Only with interest, work, and maximum financial support at

the local level can a national program be a successful program. The principle of self-supporting water supplies is new in many countries. United community action at the local level is frequently a new and untried concept. It is the task of the national organization to indicate how local communities can solve their own water-supply problems, and to bring about hope and belief that the job can be done.

12. The national program to develop community water-supply facilities generally requires the following activities, in whole or in part.

13. *Legislation.* Enactment of national legislation is a basic step toward making and carrying out a national plan. Such legislation must, as a minimum, assign responsibility for a development program to an existing organization or create a new organization, provide for financing, and fix responsibility for collection and administration of all funds. The legislation should also establish a directing board, specify membership and its responsibilities, and designate non-political methods of appointment and removal which will give the board some degree of autonomy.

14. *Surveys.* It is essential that the national organization provide for collection of information on existing water-supply systems as to needed improvements and construction of new facilities. This information is necessary to define the problem and to guide the planning and development of the national program. The information should be gathered by well-qualified personnel using carefully prepared questionnaires, field surveys, and personal interviews. If enough qualified engineers are not available locally, the work may be done through contracts with foreign firms.

15. *Engineering planning.* This phase requires both master and detailed planning. The most expedient means of meeting a country's water supply needs is the establishment of a priority construction schedule. Criteria to be used in determining priorities must be developed. Factors such as existing and potential commercial and economic development, the need for pure water in view of public health conditions, availability of local capital for investment in the system, and the expressed willingness of the people to pay for the service received, should receive most weight. With an initial priority list, detailed engineering work may begin. This includes engineering feasibility studies; engineering design and project reports; and preparation of plans, specifications and cost estimates for construction.

16. *Financial planning.* The key to a progressive national water-supply program is the concept that water works be self-supporting—that they be operated as public utilities in the same fashion as power and telephone companies are operated. The notion that water should be “free” to the consumer without payment of costs of source development, treatment and distribution, must be dispelled. Payments by consumers should cover the costs of operation, maintenance, administration, expansion of the system, and, as far as possible, capital costs of original construction. Sound planning, therefore, requires close estimation of all sources of income (service charges, water rates, ad valorem taxes, government grants, etc.); consideration of expenditures (administration, maintenance, repair, operation, debt service, etc.); reserve for depreciation, for expansion, contingencies, etc. The proposed construction schedule must be directly related to the

annual balance sheets in order to maintain financial stability.

17. *Training for operation and maintenance.* Experience in country after country indicates this is a most critical phase. Professional sanitary engineers and laborers are usually available in sufficient numbers to begin a program, but the absence of middle-level personnel—the treatment plant operators, mechanics, meter readers, bookkeepers, electricians, diesel operators, laboratory technicians, etc.—frequently dooms the program to failure. The responsible agency usually must institute a carefully planned local training program, carried on at sub-professional level by the agency itself or by local facilities with the active help of the agency. Outstanding graduates of the local program should receive advanced training, in foreign countries if necessary.

18. *Construction.* Only now—with a legally established and responsible authority, a national plan of attack, assured finances, and trained personnel available—is the country ready to engage in a construction program.

19. *Management.* No water-supply system once started grows and expands under its own momentum. An active, viable, responsive system is the creation of effective management. Water works management covers a wide but specialized experience in the handling of men, materials, and services in the delivery of a product for which there is no substitute. Good management results in, and is the result of, a logical policy of planned expansion, sound financing, smooth personnel relationships, efficient administration, and satisfying customer relationships. Good managers are made through a combination of on-the-job experience and academic training. Experience without training or training without ex-

perience is seldom adequate. The national water agency must assure itself that its managerial personnel have opportunity to obtain both types of knowledge.

### Kinds of Assistance Provided

20. How does the AID program, with limited resources and personnel, extend assistance to many countries? The regular staff of CWSDP is supplemented by a number of water supply experts willing to serve as short-term consultants on a world-wide basis. The accumulating experience of this body of consultants in the water problems of less developed areas (many of which are not peculiar to one area or region) steadily gains in value. This investment in knowledge and short-supply skills is protected through a method of centralized coordination. As requests for assistance are received from countries, the Washington staff is able to recommend particular consultants whose specialties and experience are appropriate. This centralized approach takes full advantage of the depth of U.S. professional knowledge, extends ideas and techniques from one area to another, and takes into account both the failures and successes of experience.

21. The advisory and consultative services provided may be divided into technical consultation, and professional development.

22. Technical consultation encompasses:

(a) Advisory services relating to AID community water-supply programs, to organization and training of personnel of indigenous or cooperative services, or to mobilization of domestic resources.

(b) Aid to other governments on economic-feasibility studies of water-supply projects, formulation of recommended rate structures, preparation of economic reports and loan applications.

(c) Technical design studies, preliminary engineering surveys, planning studies, technical feasibility studies, advice on operation and maintenance problems, etc.

(d) Socio-economic studies—general studies—on a countrywide basis, of the various agencies involved in all phases of water-supply planning; recommendations relative to legal delineation of responsibilities, consolidation or organization of an appropriate agency; study of existing revenues, methods of collection and their relation to the general cost of living; recommendations on maximum use of local materials, men, and facilities, etc.

(e) Training—through use of seminars, short courses, workshops; recommendations for use of U.S. educational facilities; institution of new courses to meet specific needs, especially in engineering management of water supplies; conduct of in-service training, etc.

23. Professional development is designed to stimulate and aid in training local sanitary engineers and managers in participating countries. Surveys are made of training needs; courses of various kinds are developed both in the United States and elsewhere; where necessary, institutions are assisted in preparing courses; criteria are set for selection of training participants. The nature of the courses being offered and other activities may be briefly reviewed:

(a) The University of Minnesota has developed a special Ground-Water Course of 10 weeks of academic and

field training. Beginning in 1959 with 43 participants from 27 countries, the course has been repeated every year since then.

(b) A similar course, developed in 1961 in Spanish and given at the National University of Costa Rica with AID assistance, will be repeated in 1963. Similar courses in other languages may be developed in other areas and regions.

(c) A team of experts in engineering management of water supply systems was recruited in 1961 for regional seminars held in Iran and Thailand, which, all together, had 90 participants from 16 countries.

(d) Arrangements with the University of Akron, Ohio, have been made for a special 3-months' course in Water Supply Engineering Management, to be given 3 times a year. Each year, 42 engineer-managers will study U.S. practice in public-utility management. They will be encouraged to establish similar training courses upon their return home. One such course was started in September 1962 at the National University of Colombia in Bogota.

(e) Pennsylvania State University is developing a series of five correspondence courses in water supply engineering specifically designed for engineers overseas.

(f) The most recent course, to begin in January 1963, is in applied design of water supply and sewage treatment plants. It will comprise from 8 to 12 months' work. The academic work is given by the University of North Carolina, which will also arrange for practical work with private consulting engineering firms.

(g) AID cooperates with the multi-

lateral health agencies (Pan American Health Organization and WHO) in developing seminars, symposiums, and courses, and in financial sponsorship of participants. These have included courses held in Cincinnati, Mexico City, and Sao Paulo on the engineering approach to financing water supply systems; a seminar held in Montevideo on methods of establishing water rates to assure that water supply systems are self-supporting; a seminar held in Addis Ababa on the overall community water-supply problem; and a seminar held in Lima on how to improve sanitary engineering education in the universities in Latin America. Through close coordination with the health agencies, AID is able by flexible budgeting to assure AID participation and aid.

### Financing

24. As mentioned above, the long-term solution to the problem of supplying potable water to communities obviously rests with the communities themselves. Outside assistance can serve as a stimulant and provide aid at critical points, but it can never be a substitute for investment by the people themselves in the improvement of their water systems. Outside assistance is readily available from commercial banking institutions when there is but normal risk involved. A high rate of return has always attracted investors and does today. However, in the last three years the establishment of certain international lending institutions has produced a dramatic shift in banking policies. Today, large amounts of money are being directed into social and economic development schemes where return from project operations is not necessarily

assured or where the return is not likely to be large enough to permit the project to compete in the open money markets. The most prominent of the international lending agencies are the International Bank for Reconstruction and Development (IBRD) (World Bank); the International Development Association (IDA), an affiliate of IBRD, and the General Fund of the Inter-American Development Bank (IDB). The principal U.S. agencies are the Export-Import Bank (Ex-Im), the U.S. Social Progress Trust Fund administered by IDB, and the Agency for International Development (AID). It is not the intention of this paper to discuss the lending policies of each named institution. While their objectives differ, there is a degree of uniformity in the criteria for judging projects presented by a borrowing nation. All these lending agencies seek to determine whether: (a) the project contributes to economic development, (b) is consistent with development planning, (c) is economically and technically sound, (d) adequate self-help measures are being taken, (e) there is ability to repay, and (f) financial assistance from other governments or private sources has been adequately considered. (1)

25. The IDB has possibly loaned more money for social-development activities, including water and sewerage facilities, than has any other organization. It is of interest to hear the views of this agency as expressed by its President, Mr. Felipe Herrera, at the Third Annual Meeting, April 23, 1962. "We have seen that the basic function of foreign public credit is to promote the mobilization of national action and energies. Our loans have not in themselves created the administrative bodies to manage them; but they have

moved the governments to create them or reorganize them; they have encouraged the beneficiaries to seek out national contributions representing the savings and efforts of the local community. . . . We are convinced of the need to create favorable living conditions: only in this way can be provided proper conditions for increased productivity and greater well-being. . . . As to our financing of water supply and sewerage projects and community sanitation in general, the Bank has made loans from its own funds for programs which could improve the conditions for economic development. Subsequently (from the Trust Fund) we have undertaken the financing of works which more directly affect the general welfare. As of December 31, 1961, we had loaned more than U.S. \$24 million of our own funds and more than U.S. \$40 million from the Social Progress Trust Fund for water supply and sewerage projects. In addition, operations approved by the Bank during the first quarter of 1962 total U.S. \$63 million. In short, we have contributed to 23 projects totaling U.S. \$127 million and benefiting 10 million people. . . . We believe we are helping to satisfy a collective need which has been neglected in practically all countries. . . . In our first 14 months we have approved loans for projects which help to meet the requirements for either water or sewerage, or both together, in the following cities: Concepcion, Talcahuano, Cali, Cucuta, Medellin, Cartagena, Quito, Puerto Barrios, Arequipa, Montevideo, San Salvador, Rio de Janeiro and six state capitals in northeastern Brazil (Salvador, Recife, Natal, Maceio, San Luis and Terezina). In addition, we have helped fill these same needs in over 5 hundred small communities and rural districts in the following countries: Mexico, El

Salvador, Guatemala, Brazil and Venezuela.” It is believed these words reflect a changing philosophy in banking, a recognition that loans made for water supplies and other social development purposes are as important as, and more than complement, loans for economic development purposes.

26. While the IDB has been most active, other agencies have also been busy. A complete tabulation of loans made for improved water or sewerage facilities is not readily available. However, the following totals have come to the attention of the writer:

Inter-American Development	
Bank .....	\$127,000,000
Export-Import Bank .....	18,500,000
International Development As-	
soc .....	4,400,000
AID .....	*13,500,000
U.S. Govt. (P.L. 480) .....	5,000,000
	<hr/>
Total .....	168,400,000

\*The predecessor agency of AID assisted in financing community water-supply developments mainly by grants to countries or to water-development authorities established by the countries. Some grants may be given by AID in the future but it is expected that the majority of such projects in which AID participates in capital financing will be financed by loans. This is in keeping with the legislative intent of the U.S. Congress that economic developments should be financed by loans to the maximum extent practicable.

27. The total is more than five times the amount loaned by these institutions for water or sewerage improvements in any similar period in the past. In addition to the money obtained by loans, the countries involved will themselves contribute the equivalent of between US\$100 and US\$150 million, as the loans represent approximately 60 percent of the total costs of the projects.

It is fair to say that the approach and

kinds of services utilized in the cooperative programs fostered by AID have had much to do with the recent large increase in international loans for water supply purposes.

### Summary

28. The Community Water Supply Development Program encourages and assists cooperating governments to plan, construct, operate, and manage self-supporting municipal water supplies, with the objective of water service to a majority of the inhabitants of the cooperating country. The presence of such water supplies removes many health hazards and stimulates both social and economic development within the country.

29. The centralized world-wide approach utilized makes possible:

(a) Optimal utilization of the limited number of U.S. water-supply experts (both direct-hire and short-term consultants) capable of providing expert consultation on planning, organization, management, technical, legal, and fiscal matters.

(b) Granting of limited funds to pilot projects where basic plans have been made and limited financial assistance can help to establish effectively the desired institution or agency.

(c) A central reservoir of knowledge to aid countries in developing sound fiscal planning, essential to preparing requests for external loans for the design and construction of self-supporting water supply systems.

(d) The extending, from one area to another, of techniques and methods that have been tried and found to be successful.

(e) A central point for coordinating

the CWSDP of AID with similar programs of the international health agencies.

30. The CWSDP gives special attention to the training and professional development of national personnel. The capabilities of local workers are increased through:

(a) Short-term training courses, seminars, and special courses developed specifically for foreign technicians.

(b) Long-term university training courses in the fields and engineering management.

(c) Assistance to and participation in the training activities of the international health organizations.

31. One of the most important aspects of the AID program (and of the other international programs) is the criterion of self-support. Slowly, the principle is being accepted that water is a commodity. As in the case of other commodities, the population served is willing to pay processing and delivery costs to obtain a reliable, high-quality product. Local support also promotes better maintenance since people tend to value and care for that which has cost them money or effort.

### Annex of Figures I-IV and Explanatory Note

32. Activities have been undertaken in 42 countries since AID established the CWSDP. The world-wide character and growth of the program is best seen by examination of figures I to IV. Figure I shows those countries served by CWSDP during the years 1960-61-62. Figure II shows the eight countries assisted during FY 1960, i.e., between July 1, 1959 and June 30, 1960. They are: Colombia, Costa Rica, Lebanon, Paraguay, Puerto Rico, San Marino, Turkey, and Yemen. Figure III depicts the site of initial activities during FY 1961. The following 25 countries were assisted: Brazil, Ceylon, El Salvador, Ethiopia, Greece, Guatemala, Honduras, India, Indonesia, Iran, Iraq, Jamaica, Jordan, Nicaragua, Panama, Peru, Somali Republic, Spain, Syria, Thailand, Trinidad, United Arab Republic, Uruguay, Venezuela, and Yugoslavia. Figure IV indicates the 9 countries where assistance was first extended during FY 1962 (July 1, 1961, to June 30, 1962). They are: Burma, Camerouns, Chile, Ivory Coast, Malagasy Republic, Mali Republic, Niger, Senegal, and Upper Volta. In most cases, assistance initially begun in FY 1960 or FY 1961 was being continued in FY 1962.

### REFERENCE

(1) Picton, W. L., K. L. Kollar, *The U.S. Consulting Engineer in the Foreign Field*, Civil Engineering (July 1962).

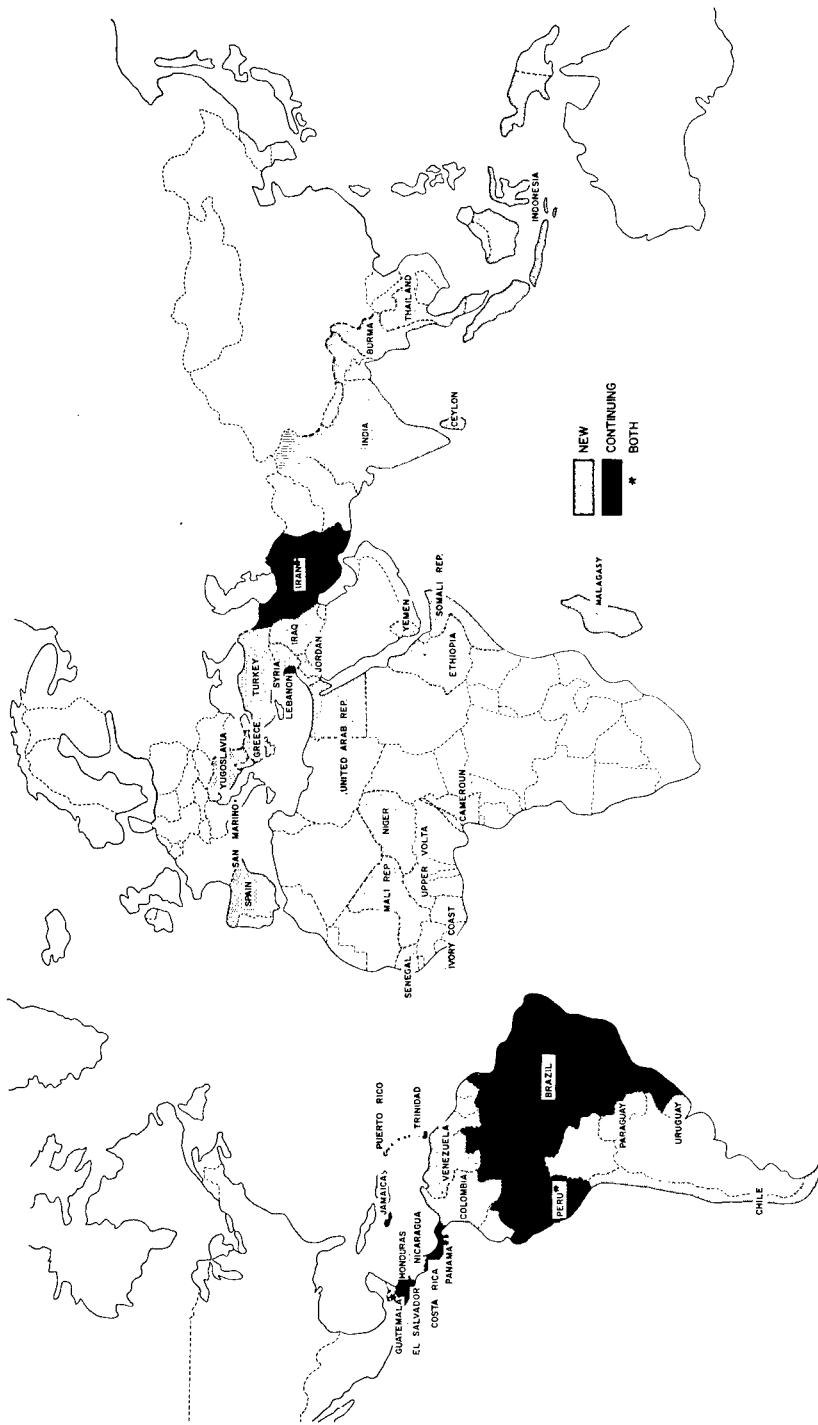

FIGURE 1. Countries served by the Community Water Supply Development Program during the years 1960-61-62.

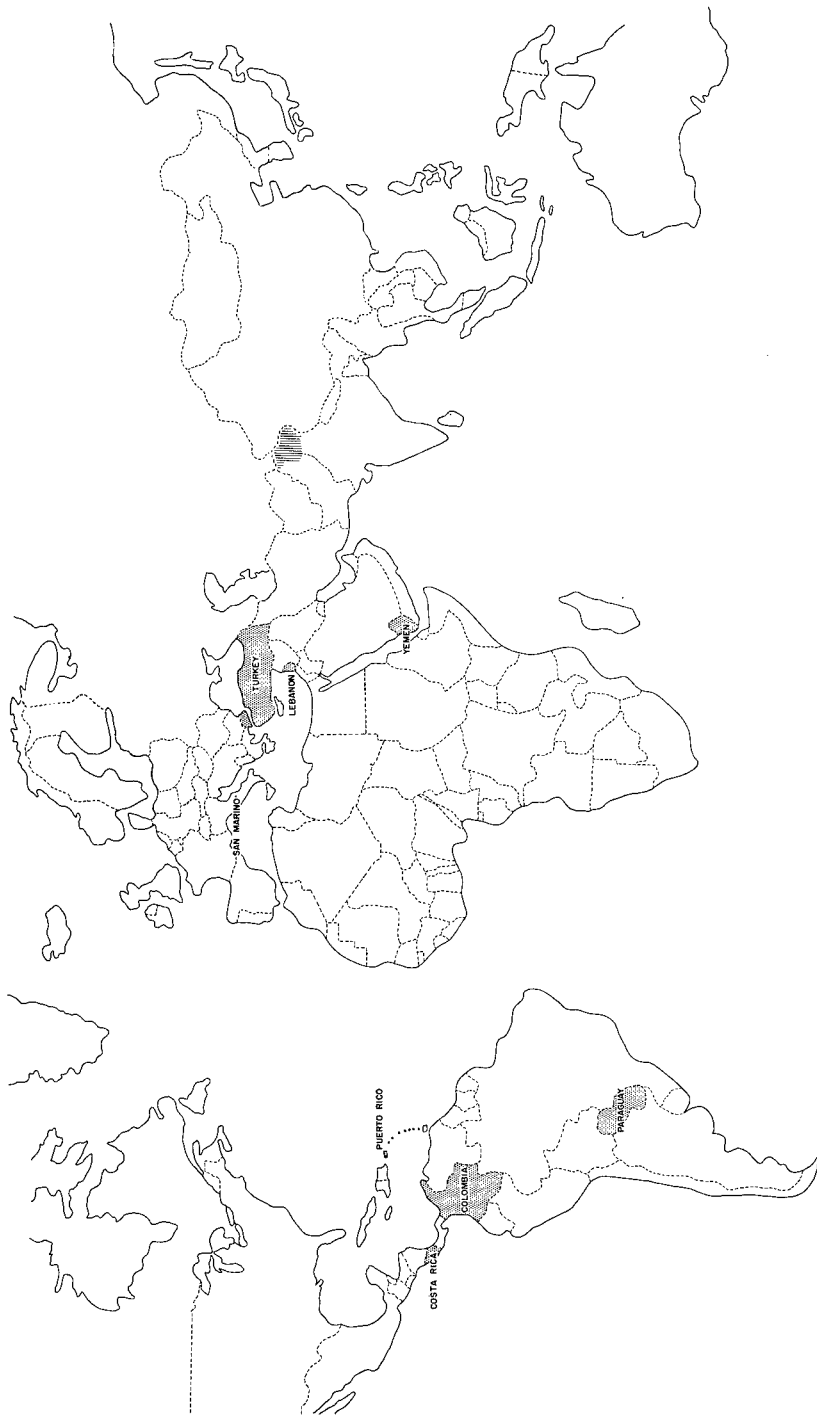

FIGURE II. Countries served by the Community Water Supply Development Program 1960.

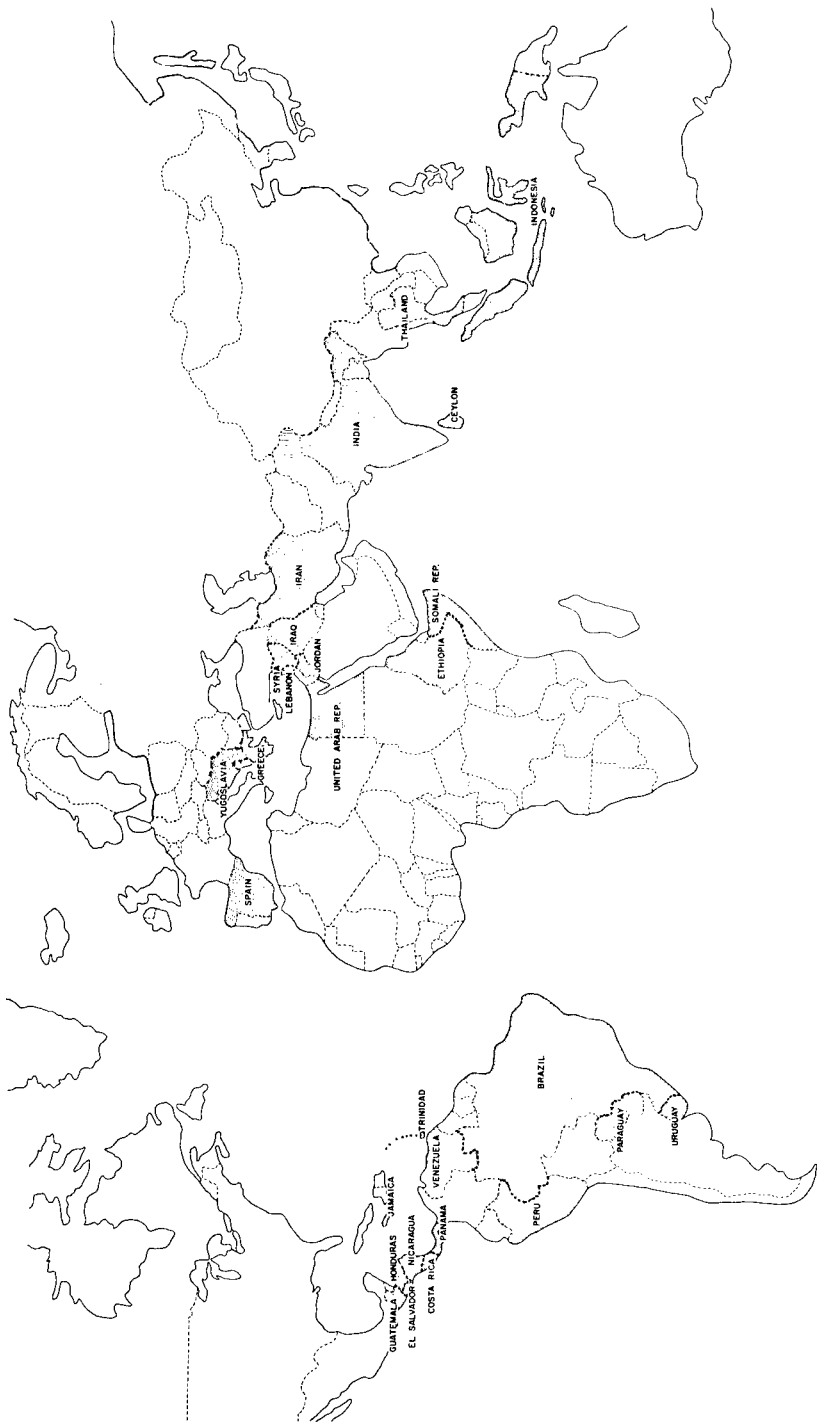

FIGURE III. Countries served by the Community Water Supply Development Program 1961.

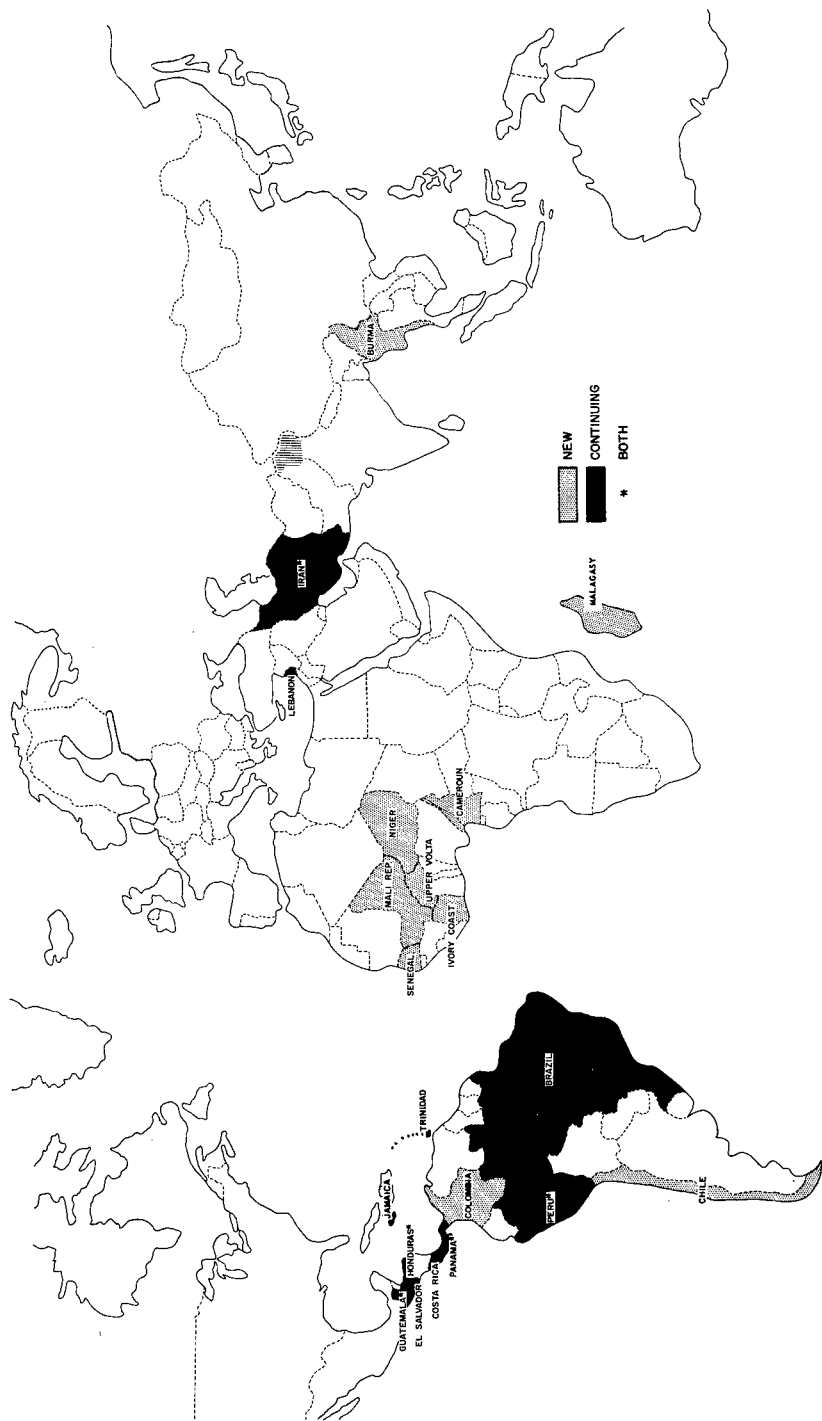

FIGURE IV. Countries served by the Community Water Supply Development Program 1962.

---

# Low Cost Waste Treatment— Waste-Stabilization Ponds

EARNEST F. GLOYNA

*Professor of Environmental Health Engineering, The University of Texas,  
Austin, Texas*

## Abstract

1. For smaller communities, the waste-stabilization pond is probably the most economical means of treating domestic waste waters. In many larger communities, this form of biological stabilization is also practical and useful. Where initial dilution water and space are available, waste-stabilization ponds can be effectively used to treat excess activated sludge, which is ordinarily stabilized by the more expensive anaerobic digestion method.

2. This paper specifically describes the development, use, and design of waste-stabilization ponds. By drawing upon experimental evidence and operational plant data, design equations have been formulated. The factors involved in this biological process are discussed.

## Introduction

3. There seems to be a growing tendency for people working in the general area of water resources to think in terms of waste treatment, water recovery, and, hopefully, nutrient separation. The more populous and highly industrialized areas,

with few exceptions, must plan on water reuse and water recovery; while in areas that are not so highly industrialized and, possibly, where income levels are lower, people must look toward waste-water treatment with the lowest expenditure of capital funds and minimum technical supervision. In larger systems, the biologically stabilized waste water must be treated to the point where it contains acceptable concentrations of enteric indicator organisms and dilutable amounts of biochemical oxygen demand (BOD). Also, in cases where streams are an integral part of a water-resources program, treatment of the waste water extends beyond the concept of pathogen control. In these cases, the waste-water control program must consider the total effect of all added materials. Consideration must be given to inorganics, complex organics, and, particularly, nutrients in the form of nitrogen and phosphorous. Thus, waste-water treatment by biological means, stream management, and water reuse may be expensive. Obviously, a full and detailed water-resources development program is not always required.

4. There are many more communities which require only bare basic waste-

treatment facilities. A sewage-collection system, followed by aerobic or anaerobic biological stabilization of the organic fractions of the waste and, possibly, disinfection, is essential. Pathogen control and stabilization of the waste in preparation for dilution are the basic considerations for the small community.

5. The purpose of this paper is to describe the advancement of waste-water treatment technology as it applies to low-cost waste-stabilization ponds. Encompassed in the following discussion are the use and acceptance of this treatment concept in the United States, the controlling factors involved in design, relative costs of operation, unique uses of the system, and a design equation.

#### Current Use

6. Sewage or waste-water stabilization ponds, sometimes referred to as lagoons or oxidation ponds, are not new. The name waste-stabilization pond, for lack of better definition, is a system which describes a more recent engineering development of the earlier sewage lagoons. For centuries, the Chinese and some European countries have used a form of sewage lagoons for treating domestic waste waters, and at the same time have used the algal growths to produce edible fish. Engineered sewage lagoons and oxidation ponds have been used in Texas, USA, for at least 50 years.

7. Today, waste-stabilization ponds are found throughout the United States and in many other areas. It is estimated that waste-stabilization ponds comprise over 10 percent of the secondary type sewage treatment plants in the United States (1) (2). There are in excess of 2 thousand acres of pond surface in the State of Texas alone. Most of those in

Texas are used as secondary treatment schemes. However, in the Missouri River Basin of central U.S.A. there are over 3 hundred communities which use ponds as the only mode of treatment (3). There are about 50 pond installations in Montana (4), and many more in South Dakota (5), (both in the northern United States)—just to indicate the effectiveness of this method of treatment in colder areas. There are also operating ponds in Minnesota (6), Pennsylvania (7), Wisconsin (8), and Michigan (9). These ponds are found especially useful throughout the semi-arid southwestern section and the more moderate temperature regions of the United States (10-13). Other countries either actively using or experimenting with low-cost waste-treatment systems include Canada (14) (15), Union of South Africa (16), Sweden (17, 18), Australia (19), Israel (20), New Zealand (21), and Norway (22).

8. The potential adaptability of these pond systems to migrant types of populations, such as military installations, is particularly good (23). The fact that the ponds can be quickly built with machinery usually available, and the fact that little equipment, such as pumps and air compressors, is required, make these ponds particularly suitable as low-cost installations. However, it must be emphasized that these ponds, as with all types of treatment, require adequate maintenance and operation.

9. Until recently, most of the waste-stabilization pond facilities have been designed as secondary treatment units, but today the potentialities of these ponds for the treatment of raw sewage is becoming more widely appreciated. The use of both larger ponds and surface aerators in the first ponds of a series help in treating raw sewage. In cases of population

growth, future plant additions may include pretreatment or addition of mechanical aeration devices to the first stage of a stabilization pond.

### Algal Cycle

10. A simplified example of an algal "lysis-synthesis" cycle for carbon is shown in figure I. Through the use of outside energy, namely sunlight, it is possible to stabilize organic wastes, synthesize food-stuffs from inorganic wastes, convert organic wastes substance into usable organic material, and concentrate trace elements. In a waste-stabilization pond, it is equally probable that there are some algae present that utilize dissolved organic compounds directly as carbon and nitrogen sources.

11. A more realistic operational sketch of a waste-stabilization pond and the environmental characteristics are shown in figure II. It is to be noted that there must always be an algal-bacterial balance. If there is a constant input of usable food-stuff, there must be a constant input of oxygen to act as the hydrogen acceptor during bacterial metabolism and the conversion of complex organics to carbon dioxide. This oxygen for the aerobic sections of the ponds must come from surface turbulence or from photosynthesis. Dissolved oxygen may be produced and stored in the pond, depending upon the amount of sunlight, algal activity, depth of light penetration, and balance of bacterial to algal activity. Obviously, during periods of darkness when there is no energy being added and when there is also algal respiration, the dissolved oxygen may be completely consumed. In some cases the oxygen may be consumed as rapidly as it is produced. There is usually a section in deeper ponds that func-

tions as an aerobic system, but normally there is no measurable dissolved oxygen present. In this section, the photosynthetic and diffused oxygen is utilized by bacteria as rapidly as it is made available. It is for this reason that a positive oxidation-reduction potential measurement can be obtained below the point where free dissolved oxygen can be found. This level, where there is no measurable dissolved oxygen but where there is a positive oxidation-reduction potential, migrates vertically, depending on available light and organic loading characteristics. Finally, at the bottom of the pond there will be a truly anaerobic environment. Potential odors produced at this section will not be noticeable at the surface as long as there is sufficient depth to act as an overriding oxidizing blanket.

### Design Criteria

12. The factors involved in the operation of waste-stabilization ponds are those which affect the biological environment and those which influence the operation of the physical plant. It is first necessary to satisfy the biological demands. To control the operation of the biological processes involved in waste stabilization, the reaction tank must be designed with respect to the physical conditions imposed by its physical environment and the biochemical work that must be accomplished. The criteria of design must, therefore, consider temperature, light, organic loading, size and shape of the pond facility, and hydraulic appurtenances. Various aspects of these criteria have been studied by a number of researchers (24-30). Briefly, each of the factors will be discussed in the following sections.

13. *Temperature.* Temperature considerations are necessary, because all the

reactions are biochemical in character. As an approximation, according to van't Hoff's theory, the chemical reaction rate is doubled for each 10° C increase in temperature.

14. Through a combination of relationships involving the mass-action law and the van't Hoff-Arrhenius equation, it is possible to demonstrate clearly that temperature must be considered (31). Naturally, temperatures used in design considerations will be extreme for any one geographic location, since the mean temperature of the pond contents will be moderated considerably by ground temperature, depth of pond, and evaporation rate. Experimental work as checked in the field indicates that the algal-bacterial reaction rate is halved for each 10° C decrease in temperature, between the range of 9° to 35° C. Thus, it becomes clear why ponds located in northern climates require longer detention periods, lower BOD loadings, and, hence, larger surface areas. In very hot and humid climates where evaporative cooling is not highly significant, reaction rates may be exceedingly fast, but a word of caution must be interjected because algal specie differentiation is highly specific for temperature. Consequently, an upper-temperature limit is also necessary, primarily from an algal maintenance point-of-view.

15. *Light.* Light-energy utilization in waste-stabilization ponds is essential, but the use of light is complicated by several factors. For example, the biological cultures are not homogeneous; there is occlusion of light in varying degrees by scum formation; there is liquid stratification; there is algal stratification; and there is a strong climatic influence. Actually, oxygen production in waste-stabilization ponds operating diurnally

on an aerobic-anaerobic cycle is influenced much more by variation in algal population than by the light-intensity variations occurring under diverse outdoor seasonal and meteorological conditions.

16. In photosynthesis, there is only a limited amount of light energy that is utilized by algal cells if no vertical mixing is assumed. For example, the incident sunlight intensity at noon on a clear day is at least 8,000 foot-candles in temperate latitudes, whereas the saturation light intensity for *Chlorella pyrenoidosa* is about 600 foot-candles. The fraction ( $f$ ) of the light energy utilized in photosynthesis by a homogeneous algal suspension (32) is given by Equation 1, and the light intensity in a homogeneous *Chlorella* suspension is decreased in accordance with the Beer-Lambert Law, (33) Equation 2.

$$f = \frac{I_s}{I_0} \left( \ln \frac{I_0}{I_s} + 1 \right) \quad \text{Eq. 1}$$

$$I = I_0 e^{-kcd} \quad \text{Eq. 2}$$

where  $I_0$  = original light intensity

$I$  = intensity subsequent to passage

$I_s$  = saturation intensity

$k$  = concentration

$c$  = absorption coefficient

$d$  = depth

17. Fortunately, there is vertical mixing and algal migration. For example, the integrated annual light-intensity in Austin, Texas, is about 2,100 foot-candles, and if  $I$  is not permitted to drop below 24 foot-candles (28) the depth should be limited to 35 cm. Yet significant numbers of algal cells and high oxygen content are found at depths greater than 2 meters even when dense algal blooms are present near the surface, indicating considerable vertical mixing. Certainly,

such mixing occurs in the aerobic zones of the deeper ponds.

18. *Organic Loading.* The organic loading as measured in terms of a 5-day, 20°C biochemical oxygen demand (BOD) influences the rate of algal-to-bacterial activity. An overabundance of readily available organic nutrient will create undue bacterial activity, and if the unbalance is sufficiently great, true anaerobic conditions will prevail. At the transition point between a complete anaerobic system and aerobic development, the algae tend to disappear.

19. The Texas State Department of Health has, through long experience with waste-stabilization ponds in a wide variety of climatic conditions, used a conservative loading figure of 50 pounds of 5-day BOD per acre per day (Lb/Ac/D). A statistical review of nearly 2 hundred installations showed that the mean load was only 34 Lb/Ac/D, and the mean effluent was 25 milligrams per liter (mg/L). Considering that these are mostly secondary treatment units and that the loading is low, the mean removal of 76 percent is considered adequate.

20. Field studies in Missouri using raw sewage also indicated that high rates of BOD removal are possible (26). Over 80 percent of the BOD was removed in influent loadings ranging from 15 to 75 Lb/Ac/D. In South Africa, engineers have recognized loadings above 100 Lb/Ac/D (16). However, it must be recognized that higher loadings require more rigid operational control and more uniform climatic conditions.

21. Laboratory and experimental ponds under ideal conditions have demonstrated that BOD loadings can be increased to several hundred pounds per acre per day (25)(34)(35). However, it must

be understood that field conditions and operational practices introduce a great number of variables. Extensive pilot plants and laboratory studies which involved varying temperatures from 9° to 35° C, loadings from 50 to 500 Lb/Ac/D, detention periods from 3 to 20 days, and depths from 1 to 4 feet, have been conducted at The University of Texas over the last 10 years. Conclusions drawn from these tests are that the detention time and reaction time can be equated. The capacity of a pond is directly proportional to detention time and volume of daily sewage flow,

$$V = Qt'$$

in which the reaction time  $t'$  is influenced by the quantity of BOD to be stabilized. An equation for the volume of a pond in terms of number of people,  $N$ ; daily per capita sewage flow,  $g$ ; average influent BOD (mg/L),  $y$ ; and average BOD value of sewage in U.S.,  $z$ ; is given in Equation 4.

$$V = Ng \frac{y}{z} t \quad \text{Eq. 4}$$

An average BOD value for domestic wastes shows that  $z$  is equal to 200 mg/L.

The term  $(\frac{y}{200})$  shows the proximal

deviation from the average BOD of raw sewage, and according to a statistical survey is a straight-line factor. The reaction time,  $t$ , required at any temperature,  $T$ , can be related to the original reaction time,  $t_o$ , at some original temperature,  $T_o$ . As shown in Equation 5, the term  $c$  is an energy temperature constant.

$$\frac{t}{t_o} = e^{c(T_o - T)} = \theta(T_o - T) \quad \text{Eq. 5}$$

Equation 5 is derived from the basic Arrhenius equation that considers the variation rate constant with temperature. Combining Equations 4 and 5 it is possible to obtain

$$V = Ng \frac{y}{z} t_0 e^{c(x_0 - T)} \quad \text{Eq. 6}$$

Equation 6 reduces to Equation 7 if a conservative value of 0.0693 is obtained for the energy temperature term, a maximum operating temperature of 35°C, and an average BOD load of 200 mg/L.

$$V = 5.37 \times 10^{-8} Ngy [1.072^{(35 - T)}] \quad \text{Eq. 7}$$

where  $V$  = volume, acre feet

$N$  = Number of people served

$g$  = daily per capita sewage flow, gpd/capita

$y$  = influent 5-day BOD, mg/L

$T$  = operating temperature, °C

22. *Size and Shape.* The design volume according to Equation 7 should be based upon the average pond temperature during the coldest month at the geographic location of any proposed installations. Therefore, with ideal domestic wastes, due consideration given to temperature extremes, a depth of 3 feet, and expert operation, the formula given in Equation 7 will work very well. However, in most cases where plants are built near residences, in areas that have extensive rainy seasons, in geographical locations that are subject to severe fluctuations in temperature, or where expert operational supervision is not available, it is recommended that the surface area be calculated on the basis of a 3 feet depth, then the pond built to a depth of 6 feet.

23. The number of pond cells that are used to create a single waste-stabilization pond system is established largely by an-

nual temperature variations. This general statement is particularly true for small installations where deep ponds are absolutely required for winter operations, but shallower ponds could be used during the warmer months. The number of ponds for installations larger than 10 acres is determined by terrain and maintenance problems. Cells of 50 to 80 acres work very well if the pond area is carefully prepared and corners or necks are eliminated.

24. Multiple ponds provide better mixing, but unless each cell is large enough to prevent complete anaerobic conditions from developing, the first cell may become distressed. If the first pond becomes overloaded an odor problem may result, in which case recirculation is required; and since this is expensive it is usually better to have larger single ponds for small installations.

25. Rapid mixing of untreated waste with the pond contents is advantageous. To obtain this immediate dilution, it is desirable to discharge the pond out-flow at the bottom in one or more outlets near the center of the pond. For a multiple-cell installation and where the terrain permits, a great deal of flexibility can be obtained by providing outlets at two or more ponds so that the inlet and direction of flow can be changed. This technique of changing the direction of flow helps to eliminate possible sludge banks in the influent pond.

### Coliform Reductions

26. There is a considerable reduction in coliform population when domestic waste waters are treated in waste-stabilization ponds (26)(36-39). The environment in the ponds is antagonistic to coli-

form bacteria, and there is considerable competition for the limited supply of nutrients. Furthermore, certain species of algae produce antibacterial substances such as chlorellin, and these probably contribute to the destruction of coliform (38)(40).

27. Detailed experiments conducted at The University of Texas under rigidly controlled conditions support the field results on coliform reductions. Three pond installations, each consisting of six compartmented sections, were maintained at 20°, 24°, and 35° C. The mean detention times to the center of each compartment were 1.4, 3.8, 6.2, 9.0, 11.4, 13.8 days, while the overall detention was 15.2 days. Synthetic sewage was fed to the ponds on a continuous basis, but domestic sewage containing the coliform was added batch-wise. Statistical analyses indicate that the reduction in coliform and total numbers of bacteria approach a log normal distribution. Therefore, the geometric mean and standard deviation are plotted versus the theoretical detention periods in figures III and IV. For the 20° C environment the coliform in the first three sections ranged from 4,200 to 27,000 organisms per 100 ml, compared to a range of 74 to 180 bacteria per 100 ml in the last three sections. Similar data are available for the total bacterial population. The percentage reductions for coliform and total bacteria were greater than 99 and 88 percent, respectively, as shown in figure V, and this compares favorably with field studies. It is interesting to note that a correlation coefficient of 0.78 was obtained when comparing total bacterial population to number of coliform bacteria.

28. In all the experiments, it was shown that there was an increase in the total bacterial population between sections 5

and 6. This increase has also been noticed in actual stream conditions and may be attributed to the subsequent utilization by living cells of the cytoplasm released upon lysis of dead cells (41).

### Sludge Stabilization Ponds

29. Not only can the waste-stabilization pond be used to supplement the aerobic unit processes, such as trickling filters, activated sludge, etc., but it has now been demonstrated that the ponds can also substitute for anaerobic digestion facilities. This latter case is most likely to be successful if river water is available for influent BOD dilution. A unique example is given below.

30. In 1954, the City of Austin, Texas, found itself in a typical sewage treatment predicament. The inadequate conventional activated sludge-treatment plant was converted and expanded to the Biosorption process at a cost of \$390,000.00. The plant provided continuous good results for the first time; but, while the new process solved the operational problem for maintaining a satisfactory BOD in the effluent and the immediate loading of the main plant, it did not solve the excess sludge disposal problem (42). It was estimated that the capital cost of digestors of adequate size for the 1954 load would be \$750,000. This figure did not include the cost of additional drying beds or a vacuum filter-plant installation, nor provision for future increases in load. Assuming a market in Austin for filtered and heat-dried sludge as fertilizer, which probably does not exist, there would still be a net loss of \$8.00 to \$15.00 per ton of sludge processed. The City of Houston reportedly sells sludge for an average of \$13.00 per ton, but it costs \$21.00 per

ton to vacuum-filter and process it for sale.

31. The decision made at Austin was to try the ponding system used by San Antonio for handling excess solids. At San Antonio, Mitchell Lake, with a surface area of about 700 acres, has been receiving some digester, supernatant, primary treated sewage, and excess activated sludge for a long time. After considerable study, a 270-acre tract of land was purchased as a site for the sludge-oxidation lake system. It is about two miles from the treatment plant and adjoins the Colorado River (Texas).

32. To date, three lake systems have been designed, constructed, and put into operation. The surface areas are 41, 65, and 85 acres. The capital and operating costs are as follows:

Land.....	\$120,000.00
Construction (complete)....	455,000.00

Total capital costs...	575,000.00
Operational costs.....	12,500.00/yr.

It is estimated that the operating cost during 1958 when the ponds were not loaded to capacity was \$4.80 per ton on a dry-weight basis. This represents a substantial saving as compared to other types of treatment. Also, at this time, there appears to be a fair market for the bait and larger forage fish which thrive in the ponds.

33. There have been no serious problems in the operation. Embankments were graveled to prevent erosion, and a gasoline-driven paddle wheel was mounted on a raft to disperse the floating algal masses which sometimes accumulate in a corner as a result of wind action.

34. The following is an abstract of the 1960 Annual Report of the Sewage Treatment Plant, Austin, Texas, describing the ponds:

5-day BOD (total pounds).....	3,818,505
Pounds per acre per day, average .....	55
Pounds per acre per day, maximum .....	165
Pounds per acre per day, minimum .....	0
Suspended solids, total pounds.....	5,292,549
Pounds per acre per day, average.....	76
Total flow into lakes (million gallons, U.S.)	
(a) Excess activated sludge...	100.7
(b) Digester overflow.....	4.9
(c) River water.....	4,483.7
Total flow out (M.G.) estimated....	2,877.3
5-day BOD in effluent (ppm) average .....	17.2
5-day BOD in effluent (ppm) maximum .....	42.0
5-day BOD in effluent (ppm) minimum.....	1.2

35. It should be noted that the first lake (41 acres) received an average loading of 200 pounds of BOD per acre per day, which represented 90 percent or more of the excess sludge production in 1958. This loading might cause some concern; but, by the addition of the new 85-acre and 65-acre lakes, there is sufficient lake capacity to dispose of twice the present sludge production.

#### Comparative Costs

36. The conventional biological systems cannot compare favorably on an economic basis with waste-stabilization ponds when the population contributing to the plant is relatively small. Even when a population concentration of 100 thousand exists, the per capita costs for waste treatment are still much less when stabilization ponds are used. Tables 1 and 2 have been rewritten to show a relative relationship of costs (1) (2).

37. The operation and maintenance costs of a waste-stabilization pond are

TABLE 1. *Relative per capita cost of construction for treatment plants in the United States\**

Population	Stabilization ponds	Trickling*** filters	Trickling** filters	Activated sludge
100.....	3.05	27.24	17.19	16.00
1,000.....	1.69	8.57	9.02	8.80
10,000.....	0.94	2.70	4.73	5.00
100,000.....	<i>1.00 Basis</i>	0.85	2.48	2.70

\*Data only relates contract cost, or about 80 percent to total first cost (actual dollar values in original paper).

\*\*U.S. total.

\*\*\*Without separate sludge digestion.

so much lower than those which would be required for trickling filter and activated sludge-treatment systems that there is no justifiable comparison. Table 2 shows the estimated annual operation and maintenance cost for about 3 hundred treatment plants.

38. The annual operation and maintenance costs for the primary plants are roughly equal to the trickling filter. These costs are roughly \$1.40 per capita per year.

39. If it is assumed that the excess activated sludge stabilization pond in Austin, Texas, can be compared on an equal basis, the operation and maintenance costs are \$0.25 per capita per year. At present, the ponds are receiving the BOD from an equivalent population of 50 thousand people. The estimated an-

nual operation and maintenance costs for activated-sludge and trickling-filter plants is at least five to six times the cost of keeping a pond system. It also should be pointed out that a great deal of dilution water must be pumped from the river and mixed with the excess activated sludge at the Austin plant; however, this is considered part of the quoted operational cost.

### Conclusions

40. Waste-stabilization ponds for small communities are less costly to construct and more economical to maintain than other types of treatment systems. These pond facilities lend themselves readily to an expansion, should future requirements

TABLE 2. *Relative estimated annual operation and maintenance cost*

Population	Primary plants	Activated sludge	Standard rate trickling filter	High rate trickling filter
100.....		9.20		
1,000.....	2.67	3.51	3.52	4.57
10,000.....	1.41	1.88	1.31	1.36
100,000.....	0.91	1.21	0.75	<i>1.00 Basis</i>

establish the need for more mechanical appurtenances.

41. Operation and maintenance of waste-stabilization ponds is not as critical as with more advanced biological treatment systems. However, even as each plant should be designed by a competent engineer, the waste-stabilization pond requires continuous maintenance. Marginal weed growths must be discouraged; accumulations of surface mats of algae and other floating debris must

be dispersed; embankments must be rebuilt periodically; and possibly insect-control measures must be undertaken.

42. Design criteria are now advanced to the point where facilities can be designed to adequately treat domestic-waste as well as many types of industrial-waste waters. The waste-stabilization pond concept is not the only form of wastewater treatment, and its use must be dependent on an engineering comparison of the various processes.

#### REFERENCES

- (1) Rowan, P. P., et al., *Sewage treatment construction costs*, J. Water Pollution Control Federation, 32, 594-604 (June, 1960).
- (2) Rowan, P. P., *Estimating sewage-treatment plants operation and maintenance costs*, J. Water Pollution Control Federation, 33, 111-121 (February, 1961).
- (3) Heuvelen, W. V., et al., *Waste-stabilization lagoons*, J. Water Pollution Control Federation, 32, 909-917 (September, 1960).
- (4) Brinck, C. W., *Operation and maintenance of sewage lagoons*, Water and Sewage Works, 108, 5, 194 (May, 1961).
- (5) Carl, C. E., *Waste treatment by stabilization ponds*, J. of Milk and Food Technology, 24, 147-151 (May, 1961).
- (6) Floan, D. R., *Installing a sewage lagoon and lift stations*, Water and Sewage Works, 108, 5, 194 (May, 1961).
- (7) Sidio, A. D., R. T. Hartman, Paul Fugazzoffo, *First domestic waste stabilization pond in Pennsylvania*, Public Health Reports, 76, 201-08 (March, 1961).
- (8) Mackenthun, K. M., C. D. McNabb, *Stabilization pond studies in Wisconsin*, J. Water Pollution Control Federation, 33, 12, 1235-51 (December, 1961).
- (9) Palladino, A. J., *Investigation of methods of stream purification*, Industrial Water and Wastes, 87-91 (May-June, 1961).
- (10) White, G. W., *New sewage lagoons replace outdated treatment plants*, Wastes Engineering, 32, 5, 242 (May, 1961).
- (11) Bartsch, A. F., *Algae as a source of oxygen in waste treatment*, J. Water-Pollution Control Federation, 33, 3, 239-49 (March, 1961).
- (12) Reid, G. W., Joseph R. Assenzo, *Culture and harvest of attached algae grown on domestic sewage*, Water and Sewage Works, 108, 248-50 (June, 1961); 264-69 (July, 1961).
- (13) Van Eck, H., *Sewage stabilization ponds—critical review*, Trans. South African Inst. Civil Engineers, 8, 137 (1958).
- (14) Anon., *Short- and long-term detention ponds at Stetler, Alberta*, Canadian Municipal Utilities, 99, 8, 36 (August, 1961).

- (15) Hefferman, J. U., *Waste-stabilization ponds in Ontario*, Industrial Water and Wastes, 6, 2, 49 (March-April, 1961).
- (16) Shaw, V. A., G. R. Marais, *A rational theory for the design of sewage stabilization ponds in Central and South Africa*, Trans. So. African Inst. of Civil Engrs., 3, 11, 205-228 (November, 1961).
- (17) Wennstrom, M., *Oxidation ponds in Sweden, a study on the pond system at Lund*, C.W.K. Gleerup, Lund, Sweden (1955).
- (18) Wennstrom, M., *Biological purification of settled sewage in shallow ponds*, UNSCCUR Proceedings, 4, 124-127 (1949).
- (19) Parker, C. D., H. L. Jones, W. S. Taylor, *Purification of sewage in lagoons*, Sewage and Industrial Wastes, 22, 6, 760 (June, 1950).
- (20) Meron, A., M. Rebhun, Y. Kott, J. B. Sless, A. M. Wachs, *Study on sewage stabilization ponds in Israel, Part I*, Report, Technion-Israel Inst. of Tech., Haifa, Israel (February, 1961).
- (21) Hicks, R., *Oxidation ponds and their use in sewage treatment*, New Zealand Engineering, 30, 3, 105 (March, 1958).
- (22) Stene, Sverre, Personal Communication (1958), The State Institut of Public Health, Norway.
- (23) Steel, E. W., *Oxidation ponds for sewage treatment*, Military Engineer, 53, 23-24 (Jan.-Feb., 1961).
- (24) Pipes, W. O., Jr., *Basic biology of stabilization ponds*, Water and Sewage Works, 108, 131-36 (April, 1961).
- (25) Pipes, W. O., Jr., *Algae growth rate*, Water and Sewage Works, 108, 5, 176 (May, 1961).
- (26) Neel, J. K., J. H. McDermott, C. A. Monday, Jr., *Experimental lagooning of raw sewage at Fayette, Missouri*, J. Water Pollution Control Federation, 33, 6, 603-41 (June, 1961).
- (27) Merz, R. C., R. G. Zehnpfennig, J. R. Klima, *Chromatographic assay of extracellular products of metabolism*, J. Water Pollution Control Federation, 34, 103, (February, 1962).
- (28) Phillips, J. N., J. Myers, *Growth rate of Chlorella in flashing light*, Plant Physiology, 29, 1952 (1954).
- (29) Oswald, W. J., H. B. Gotaas, *Photosynthesis in sewage treatment*, Proc. Amer. Soc. Civil Engrs., 81, 686 (May, 1955).
- (30) Shaw, V. A., G. v. R. Marais, *A rational theory for the design of sewage-stabilization ponds in Central and South Africa*, The Civil Engineer in South Africa, 3, 205 (1961).
- (31) Hermann, G. R., E. F. Gloyna, *Waste-stabilization ponds, III. Formulation of design equations*, J. Sewage and Industrial Wastes, 30, 963-975 (Aug., 1958).
- (32) Bush, V., *Algae culture from laboratory to pilot plant*, Edited by J. S. Burlew, Publ. 600, Carnegie Institute of Washington, Washington, D.C. (1953).
- (33) Stanford Research Institute, *Development of Chlorella culture process*, Final Report on SRI Proj. No. 191 (1950).
- (34) Hermann, E. R., E. F. Gloyna, *Waste-stabilization ponds, I. Experimental investigations*, J. of Sewage and Industrial Wastes, 30, 4, 511 (Apr., 1958).

- (35) Oswald, W. J., H. B. Gotaas, C. G. Golucke, W. R. Kellen, *Algae in waste treatment*, J. of Sewage and Industrial Wastes, 29, 4, 437 (Apr., 1957).
- (36) Neel, J. K., G. H. Hopkins, *Experimental lagooning of raw sewage*, J. of Sewage and Industrial Wastes, 28, 1326 (1956).
- (37) Parker, E. C., H. L. Jones, N. C. Greene, *Performance of large sewage lagoons at Melbourne, Australia*, J. of Sewage and Industrial Wastes, 31, 133 (1959).
- (38) Towne, W. W., A. F. Bartsch, W. H. Davis, *Raw-sewage stabilization ponds in the Dakotas*, J. of Sewage and Industrial Wastes, 29, 377 (1957).
- (39) Malina, J. F., Jr., Y. A. Yousef, *The Fate of coliform organisms in waste stabilization ponds*, Unpublished Report, The University of Texas, Austin, Texas (May 3, 1962).
- (40) Pratt, R., et al., *Chlorellin, an anti-bacterial substance from Chlorella*, Science, 99, 3511 (1944).
- (41) Stanier, R. Y., M. Doudoroff, E. A. Adelberg, *The Microbial World*, Prentice-Hall, Inc., Englewood Cliffs, N.J. (1959).
- (42) Ullrich, A. H., *Annual Report, Division of Sewage Treatment, City of Austin, Texas* (1958).

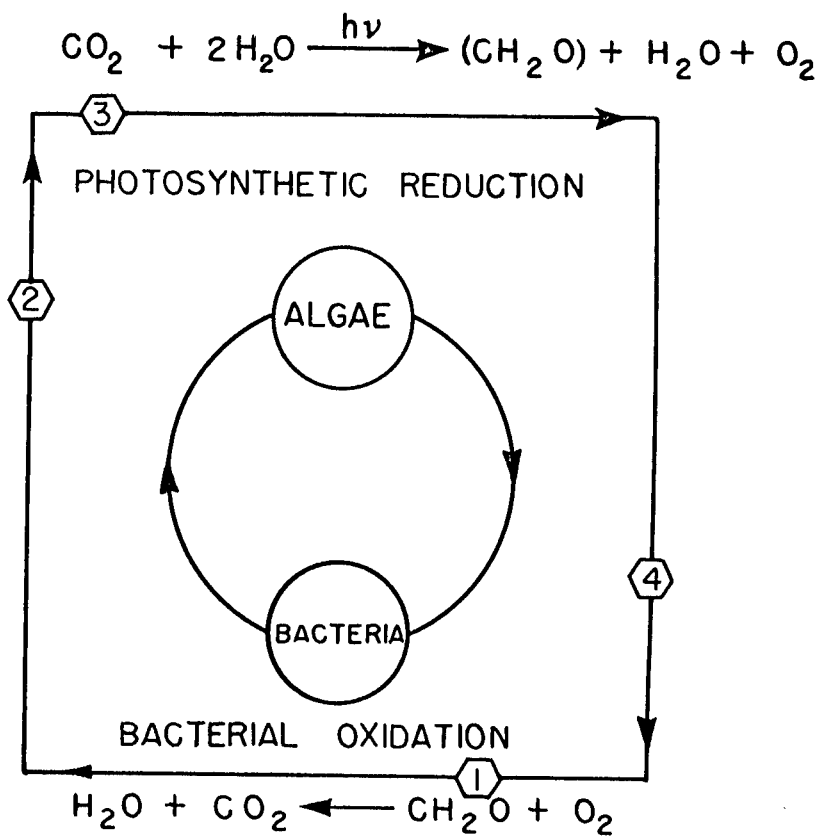

- ① ORGANIC WASTE
- ② MINERALIZED EFFLUENT
- ③ INORGANIC WASTE
- ④ ORGANIC FOODSTUFF

FIGURE I. Simplified diagram of algal-bacterial commensalism-carbon cycle.

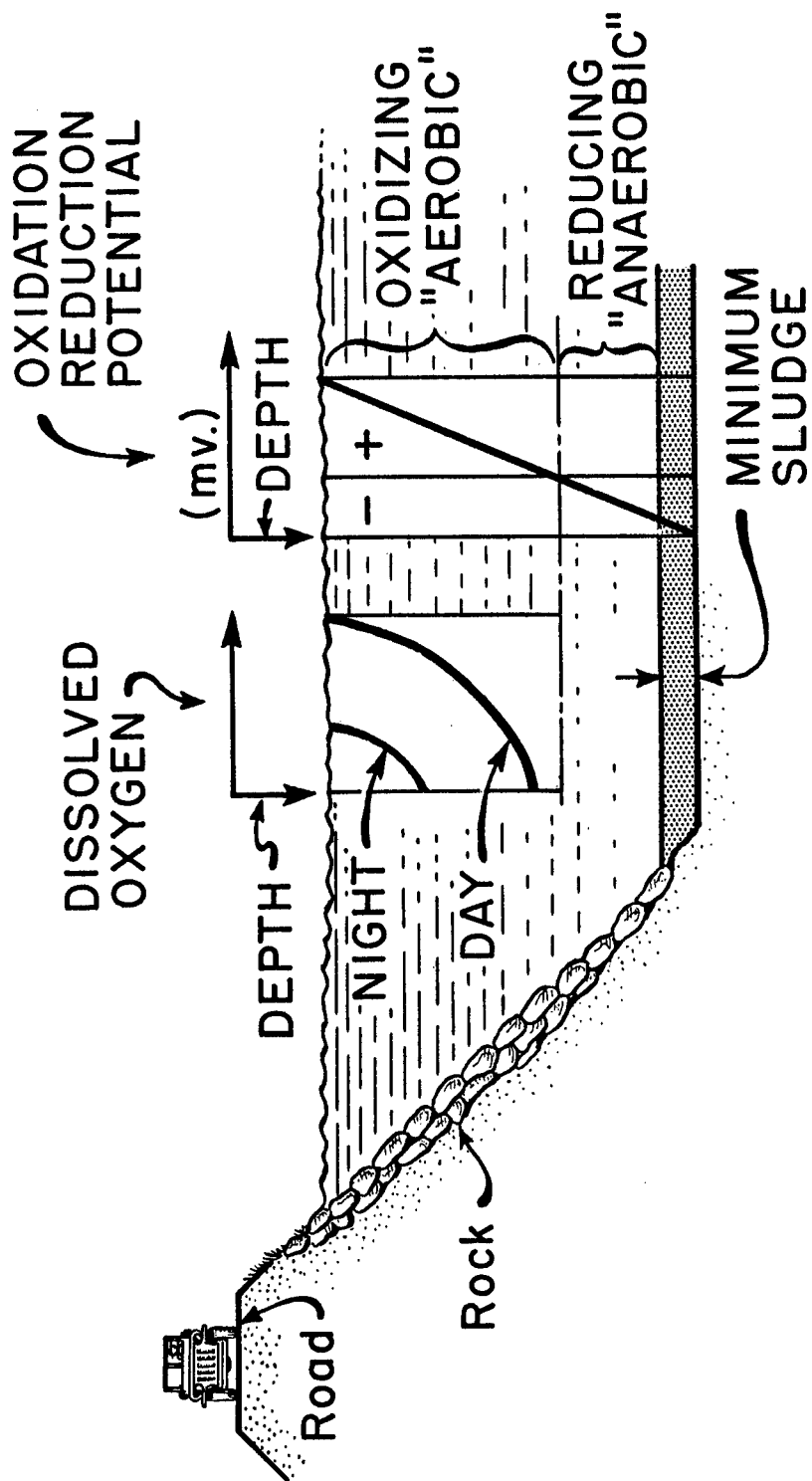

FIGURE II. Waste stabilization pond.

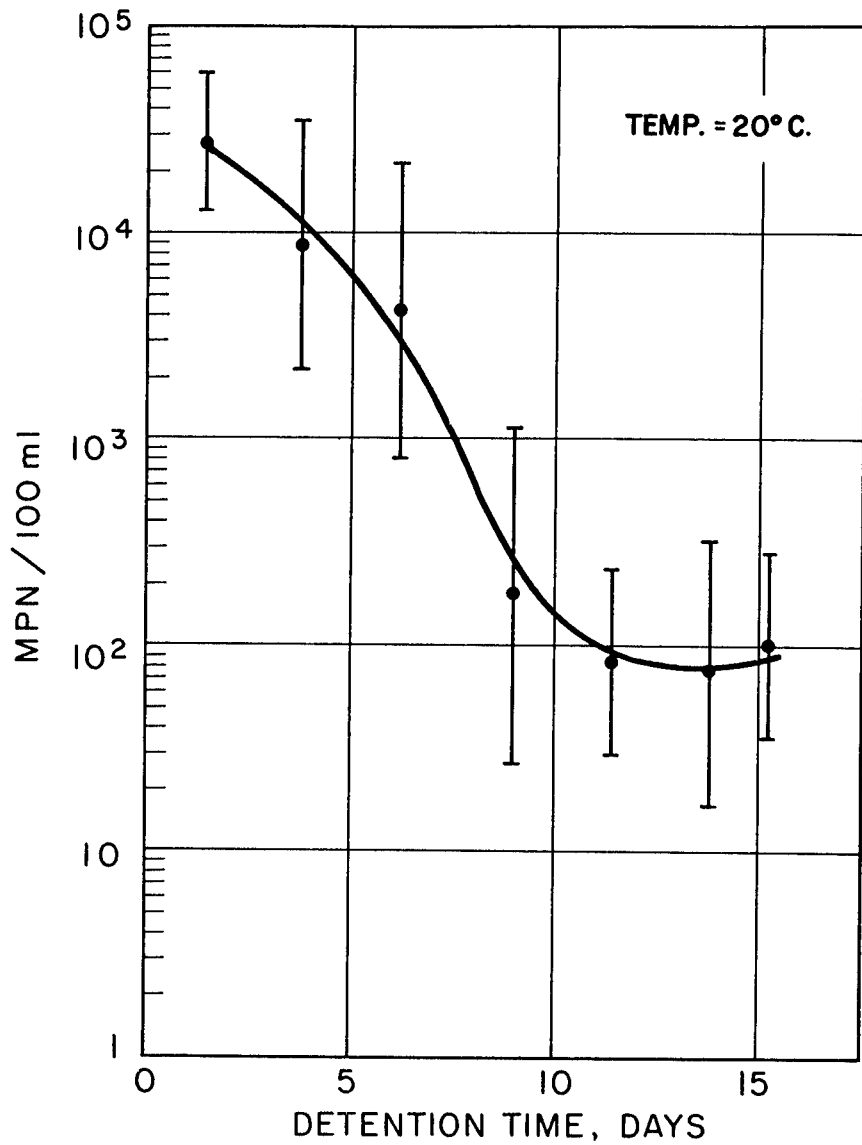

FIGURE III. Reduction of coliform bacteria in laboratory model waste-stabilization pond (Sewage added in a batch).

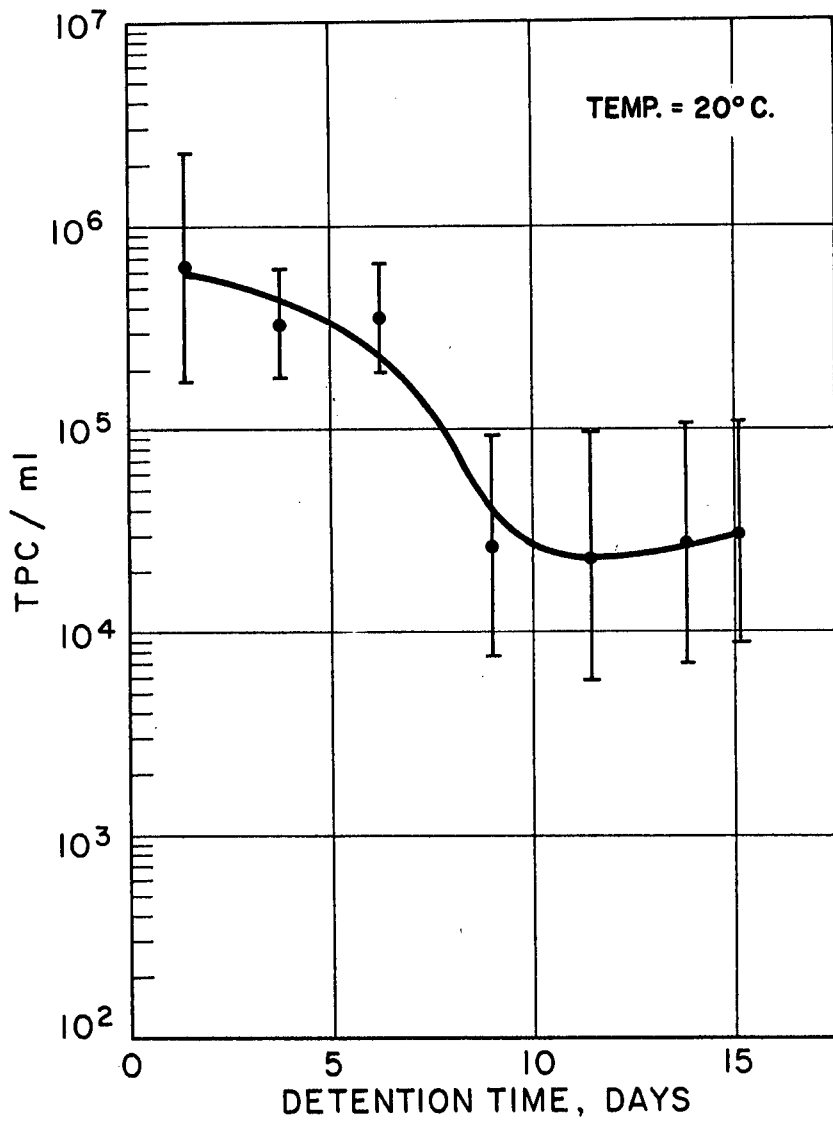

FIGURE IV. Reduction of total bacterial population with detention time (after adding sewage in a batch).

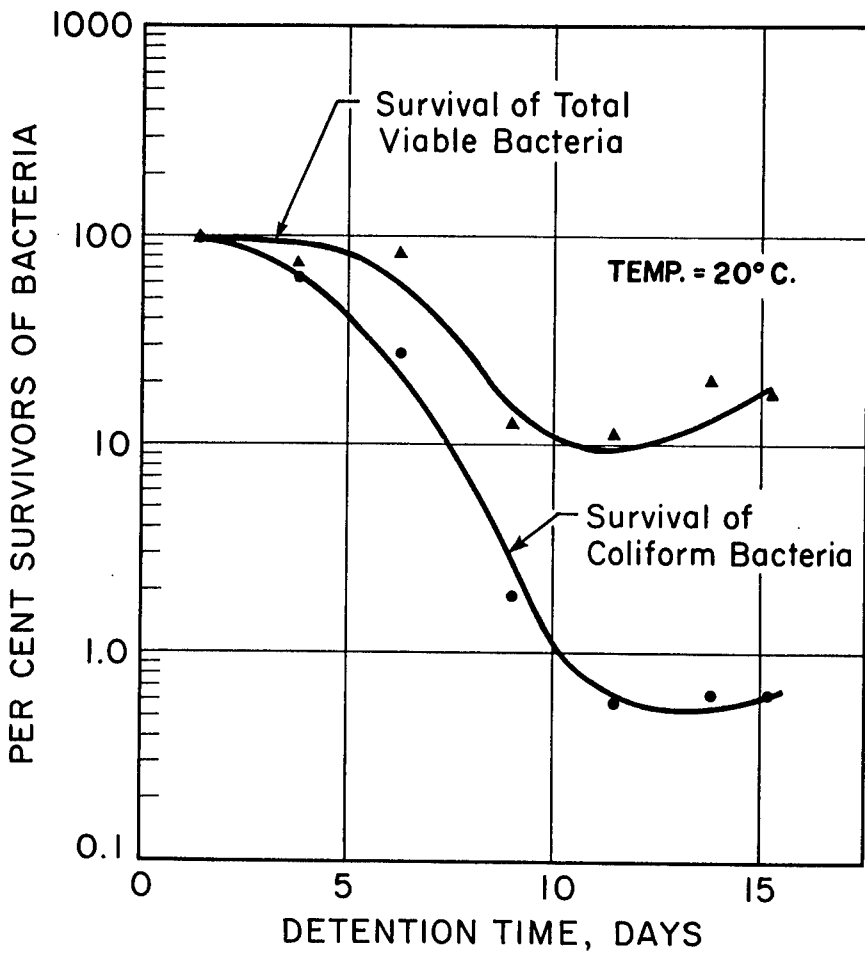

FIGURE V. Survival of bacteria in laboratory model waste-stabilization pond at 20° C.

# River Basin Planning in the United States\*

EUGENE W. WEBER

*Chief, Civil Works Planning Division, U.S. Corps of Engineers, Washington, D.C.*

MAYNARD M. HUFSCHMIDT

*Director of Research, Harvard Water Program, Graduate School of Public Administration, Harvard University, Cambridge, Massachusetts*

1. River-basin planning, as we know it in the United States today, is a product of over a century and a half of experience in adapting fast-growing human occupancy and economic activity to the great complex of land and water resources of the nation. In the early years of our country, we had to deal with much the same problems now faced by the developing nations—problems of economic growth and nation-building in the context of a rapidly growing population.

2. In the earliest efforts to expand beyond the Eastern Seaboard, the primary emphasis was on development of the rivers for navigation (1). With increasing settlement of the Mississippi Valley, major problems of flood protection arose. By 1900, settlement of the arid and semiarid lands of the West required development for irrigation. To these needs were soon added demands for hydroelectric power and for improvement of the quantity and quality of water supplies. Then, a philosophy of integrated, multiple-purpose, river-basin planning was formulated as part of a national conservation movement. It was expressed

in remarkably complete form in the 1908 report of the Inland Waterways Commission (2). Finally, when lagging economic activity provided added incentive in the 1930's, the Federal Government assumed major responsibilities for river-basin development and intensive planning was begun, resulting in the preparation of plans, at least in outline form, for most of the major river basins of the nation (3).

3. In the discussion to follow, we present first the basic concept of integrated river-basin planning and an idealized methodology for the conduct of such planning. Following this statement on the substance of planning, we examine U.S. experience in planning during the past 30 years and present some important implications for the developing areas of the world. We shall distinguish those elements of our experience that embody principles of general applicability from those unique to the United States.

## Basic Concept of Integrated River-Basin Planning

4. The concept of integrated river-basin planning, as generally understood in the

\* U.N. Conference paper.

United States, has two major elements: (a) the multiple use of individual units of river systems, especially multiple use of reservoir storage, and (b) the treatment of the river basin as a hydrologic and physiographic unit (4).

(a) *Multiple-purpose use* involves the planning and operation of projects, especially storage reservoirs, to serve all of the needs which the project can be designed to meet, to the full extent that this can be done advantageously, as compared with the cost of single-purpose or other alternative ways of meeting the various needs.

(b) *Treating the river basin as a hydrologic and physiographic unit* permits proper consideration of the interrelationship of all streams in a basin, the associated ground water, the effects of forest and ground cover, and all land-water relationships pertinent to development and use of the basin's resources. It does not preclude taking into account, in the planning, the needs or effects outside the basin which are pertinent to optimal use of the basin's resources.

### **Methodology for River-Basin Planning**

5. In general terms, the methodology of river-basin planning in the United States consists of four steps (5):

(a) *Setting the broad objectives for development.* These may be: increase in national income; economic growth; or increase in productivity and income of certain sectors of the economy, specific classes of individuals, or residents of particular regions. This step is generally the task of top policy-makers—the Executive and the Legislature.

(b) *Translating the broad development objectives into criteria for use by*

*river basin planners to formulate specific plans.* This step includes a delineation of the planning region—the river basin, group of basins, or other region for which a water-resource plan is to be prepared. These tasks of criteria-setting are functions for the central policy and planning group of the Executive, with oversight from the Legislature.

(c) *Formulating the optimal river-basin plan and schedule of development* (or alternate plans and schedules) at the local or field level, in terms of these criteria, by choosing from among the many combinations of alternative water-control structures and kinds of water-derived products and services. This central core of the planning task is generally carried out by a river-basin planning staff given specific responsibility for the purpose.

(d) *Review of the proposed river basin plan and proposed schedule* (or alternative plans and schedules), and reconsideration of the appropriateness of the objectives and planning criteria in the light of the new information obtained from the completed plan. This step (which comes full circle to Step (a)) is the joint task of the Legislature and the Executive with his central policy and planning group.

6. Often the third step—the field-level planning task—is considered to be the whole of river basin planning. Yet, without overall objectives and without specific guidance on criteria for planning or an assessment of the overall consequences of a river basin plan, field-level planning would take place largely in the dark. All four steps are essential parts of a valid planning methodology.

7. However, the third step is the heart of the technical planning process. Here

we examine further its major elements, of which there are, broadly, three:

(a) Identifying and measuring the physical, economic, and social problems and requirements of the region (in relation to the established broad development objectives) that water-resource development can help to solve or meet. This includes making projections of regional population, economic activity, and demands for water-derived products and services under various assumptions of the extent and nature of water resource development.

(b) Identifying and measuring the various opportunities for control and development of the region's water and related land resources to help meet the needs and solve the problems identified in element (a) above.

(c) Given the schedules of demand for water-based products and services, and the opportunities for meeting the demands through water development (where demands are related to the established objectives), the formulating of an optimal water development plan, including a schedule of development. This can be accomplished through systematic analysis of many alternative plans under a procedure that seeks to select successively better and better plans (where improvement is measured in terms of the preassigned objectives of development) until no further improvement can be made. In some cases, alternative plans are developed to meet different mixes of objectives.

8. In the United States, benefit-cost analysis has been highly developed as the basic tool in this process of formulating optimal plans and selecting from among alternatives. The estimated cost of the development plan under review is compared with the estimated benefits, both

usually expressed in market value terms. The object is to devise the plan with the greatest excess of benefits over costs. In general, a plan is not recommended for development unless the ratio of benefits to costs is greater than unity. Although benefits and costs are usually expressed in terms of increases in national income, they can be (and often are) expressed in other terms as well, such as income gains to special groups or regions. Intangible factors—both benefits and costs—are taken into account in the analysis, and are often given implicit weights in monetary terms.

#### **United States Experience and its Implications for Developing Areas**

9. Over the past 30 years, the United States has invested about \$30 billion in developing its river basins. These developments have varied from relatively small-scale projects, often for a single purpose, to large-scale, complex, multi-purpose undertakings such as the Tennessee Valley development and the major dam and reservoir systems in the Columbia and Missouri basins. From the experience of planning and carrying out these developments, there emerge some generalizations, insights, and principles that should be helpful to others just now starting the planning and development process. Our discussion of U.S. experience is presented in terms of three major aspects of the planning process: defining goals and objectives, formulating the river basin plan, and organizing and staffing for planning. Brief mention is also made of the problem of basic data for planning. (Although much of the planning, financing, construction, and operation of water resource developments in the United States, particularly hydro-

electric power and water supply, has been accomplished by private initiative and local governments, our discussion is centered on comprehensive, multipurpose river basin planning, which has been carried out primarily by the Federal government in cooperation with the States. We omit any discussion of the impact on U.S. river basin planning of the issues of private versus public development. Although such issues have had important effects on our experience, they are so closely tied to our institutional pattern that few meaningful lessons can be drawn for application elsewhere. For treatment of this aspect of the subject, the reader may consult the literature listed in the references, especially references 2, 3, 6, 7, 8, 16, 18, and 23.)

#### **Defining Goals and Objectives for River Basin Development**

10. The most successful river-basin developments in the United States have taken place under circumstances where there was general understanding and acceptance of the goals to be attained. Our first fully-integrated river basin development—the Tennessee Valley system—was begun under particularly favorable circumstances in this respect. The Congressional Act of 1933 establishing the Tennessee Valley Authority gave the agency a broad mandate to promote the economic growth of the region through resource development—in particular, through exploiting the navigation and hydropower resources of the river system and the fertilizer resources of the region. This general directive was given detailed substance during the formative years of the TVA, but the clear-cut regional development objective which the TVA had from the start allowed the agency to pro-

ceed with integrated planning and development in an effective way (6).

11. Similarly, the large-scale development of the Columbia River basin first began with stimulation of regional employment and economic growth as the major objectives. Bonneville and Grand Coulee dams, although multiple-purpose in concept, were noteworthy because of the large quantities of low-cost hydropower which they provided. These dams, started in the 1930's and completed in time to make a major contribution of hydroelectric energy to wartime industrial production, were followed by other hydro-projects after World War II. Regional development of the Pacific Northwest, primarily through exploiting the hydropower resources of the Columbia River, but also through irrigation, flood protection, navigation, and other resource development, remains an important goal of public policy today (7).

12. In partial contrast, the Missouri River basin development did not proceed with so general an agreement on goals and objectives. Although the broad goal of the 1943 Missouri basin development plan was regional economic stabilization and growth, in fact the upper and lower portions of the basin had quite different economic and resource problems. The solutions to these imposed conflicting demands upon the river system. As a result, compromises were necessary to meet both navigation and flood control needs of the lower basin and a reasonable development of the irrigation and hydropower resources of the middle and upper basins. Because these compromises did not fully resolve the basic conflicts in demand, problems in allocating the limited available water resource have persisted into the operation stage (8).

13. Comprehensive planning studies undertaken since World War II have attempted to deal with the problem of goals and objectives in a more systematic way. In this the studies have been only partly successful. In studies of the New England States and of the Arkansas-White-Red river basins of the Southwest, completed in the early 1950's, regional development as such was not the central objective. Rather, emphasis was placed on the contribution that water-resource development could make in meeting needs for water-derived products or services arising from the normal economic growth of the region. However, detailed projections of economic activity were not made for these regions; hence it was not possible to estimate future water-resource needs in any detail. The results of these surveys were thus presented in terms of inventories of possible water-development projects, rather than in terms of firm water-resource development plans with associated time schedules.

14. In more recent studies of the Delaware, Potomac, Southeastern, and Texas Rivers basins, attempts have been made to project regional population and economic activity over a 50-year period to serve as guides for estimating demands for water-related products and services. Although these projections can serve only as rough indicators for the pattern and magnitude of future water demands, they provide a logical and consistent basis for setting forth a plan of water-resource development in which individual projects can be scheduled over time and uses can be shifted to accommodate changing demand patterns. In fact, the water-development plan for the Delaware River basin, completed by the Corps of Engineers in 1960 in concert with other Federal and State and local agencies, presents

a schedule of site reservation and project construction to meet the projected domestic and industrial water-supply needs of the region to the year 2010 (9).

15. Most recent improvements in planning technique relating to goals, objectives, and economic projections are twofold:

(a) River-basin planning standards and criteria have been revised in 1962 to emphasize the need for clearly defining the overall goals or objectives of river development, and to distinguish among goals where conflicts are likely to arise. Thus, the objective of increase in national income is to be distinguished from objectives such as regional economic growth or increasing the income of specific classes or groups of individuals (10).

(b) Increased emphasis is being given to improving techniques of projecting regional population and economic activity, based upon a single set of national economic projections which is to be periodically revised.

16. Lessons for developing areas may be drawn from the above. Goals and objectives need to be clearly stated by top policy-makers at the start of the planning process. Ideally, these should be consistent for all subnational river basin planning groups. Overall national projections of economic activity—which may be goals or targets in some developing countries—should be developed, and regional or local projections derived from these should serve as guides to regional or local planning groups.

#### **Formulating River Basin Plans**

17. Because the methodology of formulating river-basin plans is the product of gradual evolution over the past half-

century; our experience can appropriately be described by citing a number of landmark studies. These are merely illustrative, as the present art and science of planning is the composite result of the labors over the years of thousands of engineers and physical and social scientists.

18. One of the best early examples of orderly and systematic planning for an entire river basin is the development plan of the Miami Conservancy District for the Miami River basin in Ohio. Although oriented toward but a single purpose—flood control—a rather sophisticated methodology was used to examine a large number of alternative combinations of reservoirs and levees in the search for the least costly means of achieving a given physical objective (11).

19. The inventory surveys of major U.S. river basins, executed by the Corps of Engineers in the late 1920's and early 1930's, produced a number of significant framework plans consisting of combinations of storage reservoirs designed for flood control, navigation, hydropower, irrigation, and domestic and industrial water supply. The comparisons of alternatives and economic analyses were not carried out in great detail. Yet it is noteworthy that these inventory surveys formed the basis of much of the river development work of the 1930's and even later years (12).

20. Building on the Corps of Engineers inventory survey of the Tennessee River basin (which was one of the most detailed and complete of the group), the Tennessee Valley Authority enlarged and refined the plans for the basin as the agency proceeded with its development. Many new insights into the relationships of river system structures and uses were gained in the planning, construction, and

operation of this first fully-integrated, multipurpose river basin development (13).

21. The art of plan formulation was advanced on other fronts during the late 1930's and the 1940's. The Water Resources Committee of the National Resources Planning Board stimulated comprehensive, multipurpose planning through Federal-State-local drainage basin committees in all of the major river systems of the country. Also, in 1941, this Committee prepared a statement of national water policy which contained an excellent prescription on river basin plan formulation (14).

22. By 1950, the principles of integrated planning of river basin developments had been worked out in considerable detail. Following the work of the National Resources Planning Board, a Federal interagency committee had developed an excellent statement of the principles and procedures of economic analysis for application to river basin planning (15). Yet practice lagged behind principle. Most river-basin plans were mere inventories of unrelated projects. Plans were typically oriented to one or two major purposes—flood control and navigation in the case of the Corps of Engineers, irrigation in the case of the Bureau of Reclamation—with other uses considered only as incidental. Detailed comparisons of a large number of alternative combinations and detailed optimization studies were the exception rather than the rule. But the decade of the 1950's was nevertheless a period of major advance. The principles and practices of comprehensive planning were given renewed emphasis in the studies and reports of three Presidential commissions—the Water Resources Policy Commission, the Missouri River Basin Survey Com-

mission, and the Advisory Committee on Water Resources Policy (16).

23. This period also saw a significant increase in the interest of academic scholars in river basin planning and development problems, especially in economic evaluation. For some years prior to this, a small but growing group of academic economists, largely in the Western States, had been giving attention to these problems (17). Since 1955, a number of significant works have appeared whose impact on planning is only now beginning to be felt. These studies deal principally with the economics of water-resource planning and development. They analyze current agency practices in the light of economic principles and suggest various prescriptions to be followed in plan formulation and choice among projects. Although these books and the related work of academic scholars do not provide consistent sets of rules to follow in plan formulation, they give much more detailed treatment to the problems than was available heretofore (18).

24. The most recent planning experience in the United States has begun to reflect the influences of these movements for improvement both within and outside the Federal Government. Recently completed studies of the Delaware and Potomac River basins, and of the Texas streams, are much more comprehensive in scope than previously was the case (19). The Delaware River Basin Plan, recently prepared by the Corps of Engineers in cooperation with other Federal agencies, the four States concerned, and local agencies, is a good example of a major advance toward fully comprehensive river basin planning. The basin, covering an area of about 13,000 square miles, has a relatively high population density and degree of urbanization and

industrialization, with a strong further trend in this direction. Projections of population and economic activity in the basin and adjacent areas, to the year 2010, were made for use in defining needs for water-based products or services. A wide range of possible measures to satisfy the needs was considered, including improved land management, local flood-protection works, reservoirs of various sizes, flood-plain zoning, water-quality and ground-water control, and a salt-water barrier in the Delaware River estuary. A total of 193 major and 386 small reservoir possibilities was considered in formulating the final plan, consisting of 19 major and 39 minor water-control projects. Another feature of the plan was the proposal for early acquisition of reservoir site lands in order to preserve them for future use in this densely populated area (20).

25. There is increasing concern with fundamental research in the process of river basin planning, both by the planning agencies and by university and other outside research groups. The basic research on river system planning, initiated at Harvard University in 1956, has now moved toward the application stage (21). A number of other universities are now turning to research in this field. The work done to date indicates that the analytical approaches loosely grouped under the terms "operations research" or "systems analysis" can be adapted to the planning of river-basin developments by taking advantage of the high-speed computation capabilities of electronic computers. These approaches allow the testing of many more combinations of purposes, project units, and scales of development than was possible under previous techniques. Presently undergoing an extremely rapid evolution, but already

available in a form suitable for use in connection with the problems of developing nations, these systems analysis techniques appear to have many promising applications in planning and programming of water and related land-resource development (22).

26. The implications of U.S. experience in plan formulation can be summarized as follows:

(a) Of prime importance is the way in which the planning problem is set up. We are only now learning the importance of clearly setting forth the objectives to be achieved, of developing planning standards and criteria that flow from these objectives, and of using a methodology to prepare optimal plans in terms of the standards and criteria. When the problem is set up in this way, the respective roles of top policy-makers, central office planners, and river basin technicians in the field emerge clearly. In setting up the task of field-level planning, it is important to view it in comprehensive terms, to include within the purview of planning all relevant purposes and all reasonable means and measures (structural and non-structural) of accomplishing the purposes. The dynamic nature of water resources investment must be recognized; scheduling of investment becomes an integral part of the choice of project and purpose mix. In examining the many alternative river-basin plans, a systems approach should be used that takes into account the technological elements of (1) multipurpose use of water-control structures, (2) hydrologic and physiographic unity of river basins and surface-ground water complexes, and (3) the interrelations between the land resource and surface and ground water

flows. Analysis of alternative plans should be not in terms of physical outputs alone, or even primarily, but should be framed in economic terms. It is here that U.S. experience with benefit-cost and systems analysis can be useful.

(b) *Benefit-cost analysis in monetary terms can serve as a base for weighing intangible considerations.* Alternative plans that include provisions for achieving non-economic objectives can be compared with plans which are optimal from an economic standpoint. Such comparisons provide a valuable aid to judgment on the extent to which a departure from the economically optimal solution is warranted in the interest of attaining or preserving intangible values.

(c) *Planning river basin developments should be considered as only a part of total investment planning for all sectors of the economy.* This proposition follows from (a), for if the water investment planning task is set up in terms of meeting broad national objectives, it will need to be adapted to the total investment program. De-emphasis of physical results or outputs will serve to remind decision-makers that engineering structures, no matter how grand or impressive in scale or design, are not ends in themselves, but are means toward serving human needs.

### Organizing and Staffing

27. The problem of organizing for effective planning of river-basin development covers a wide spectrum. Some river basins may lie in an area under the political and managerial control of a single entity. Here the problem would

be reduced to assembling and managing the necessary skills. More often, a river basin spans more than one political jurisdiction and involves more than one agency having technical or managerial responsibilities. Also, the political jurisdictions may include more than one national sovereignty. In the United States, river-basin planning experience has embraced the entire range from single-entity control to multi-agency, multi-political and even international jurisdictions.

28. *Agency functions.* Some of the agencies have already been mentioned in the previous discussion. A more complete catalogue is presented below.

29. Planning for the use of rivers for inland navigation is the responsibility of the Army Corps of Engineers, a federal agency. Flood control planning is also carried out primarily by agencies of the National Government—the Department of Agriculture working on upper watershed protection in cooperation with local soil conservation and watershed districts organized under state laws, and the Army Corps of Engineers which plans major reservoir control and other flood protection measures. Large-scale irrigation planning in the West is assigned to the National Government's Bureau of Reclamation in the Department of the Interior. This Department also has power-marketing responsibility for hydroelectric energy generated at federal water projects, and nationwide responsibilities for assembly of basic hydrologic data; geologic surveys and topographic mapping; and survey, research, regulatory, and management functions for minerals, public lands, national parks, fish and wildlife resources, and outdoor recreation. The Department of Agriculture also has major forestry research and management responsibilities.

In general, state governments also have numerous agencies concerned with this range of functions.

30. Providing domestic and industrial water supplies is primarily the responsibility of individual communities, local water districts, and the states, but the Public Health Service in the Federal Department of Health, Education, and Welfare has survey, research, and regulatory responsibilities for water supply and control of pollution. Several other federal agencies have authority to help in developing water supplies and improving water quality.

31. Other agencies of the central government actively concerned with river-basin planning include the Federal Power Commission and the Department of Commerce.

32. In addition to the numerous federal agencies involved, the states, interstate and intrastate, and local interests, both public and private, often have a significant role in the planning process. Some states, notably California, have sizable planning and development agencies of their own. In recent years, participation of the states in river-basin planning has increased significantly.

33. The great range of interests involved in a modern river-basin study has led us to experiment with various integrating or coordinating devices. The Tennessee Valley Authority was such an experiment, in this case giving almost all national planning and development authority to a single regional agency, but leaving State and local authorities relatively untouched. Informal federal inter-agency committees, with state participation, were set up in the Missouri and Columbia River basins, and special planning committees or commissions with federal agency and state representation

have been used in the Arkansas-White-Red basins, New England-New York region, and the Texas and Southeast river basins. In other cases, such as the Delaware and Potomac basins, a single federal agency, the Corps of Engineers, has taken the leadership in planning, with participation from other federal and state agencies through committees. A federal-state commission has recently been established by interstate compact to guide further planning and development in the Delaware basin.

34. None of these arrangements has proven to be fully satisfactory or universally applicable in the United States. There is now before the Congress a proposal by the President to establish federal interagency planning commissions with state participation, as required, for all major river basins (23).

35. Although U.S. experience with organizing for planning is specialized and unique, one generalization emerges. So many different interests—national, regional, local, public and private, rural and urban, agricultural and industrial—impinge on the planning process, that no single planning agency can have purview of all of them. Thus, in developing countries as in the United States, coordinating arrangements and devices will still be necessary, even when the core task of preparing the river basin plan is assigned to a single agency with broad responsibilities.

36. *The international aspect.* The United States has entered into formal arrangements affecting river-basin planning with both of its adjoining neighbors, Canada and Mexico. The International Joint Commission, United States and Canada, is a permanent body to which the two countries may refer problems of mutual concern for study and recom-

mendation. This agency provides the structure through which the appropriate agencies and interests in each country can deal with problems of planning for development of rivers that cross or form the boundary or that flow into or out of boundary waters (24). The International Boundary and Water Commission, United States and Mexico, was formed to administer the development of certain specific projects and to prepare plans for additional development on rivers of mutual concern (25).

37. On the whole, both arrangements have worked well. The organizations have been used effectively for coordinating the collection and analysis of basic data, as well as planning and development activities. They have demonstrated the feasibility of two different arrangements for planning: one through the use of established organizations in each country; and, the other, through the use of a special organization administered by representatives of each country. The experience of these organizations with a wide variety of problems may well prove useful to other nations involved in international river basin planning.

38. *Staffing for planning and development.* As river basin planning grows in complexity and scope, and as closer coordination of separate governmental jurisdictions and agency functions is required, an approach based too exclusively on narrow technical disciplines is far too restrictive. We have found that modern river basin planning requires the application of the talents and skills of many disciplines. The lesson for developing nations is clear. Staff for river basin planning should be composed of an interdisciplinary team, including not only a wide variety of types of engineers and physical scientists, including civil

engineers, hydrologists, meteorologists, geologists, agronomists, soil scientists, and biologists, but also experts in economics, geography, mathematics, sociology, social psychology, political science, law, statistics, and management and administration, among others. In addition, in less-developed nations, the river basin plan should include projections of needs for professional and skilled manpower to carry out the plans and to use the completed facilities, and definite proposals for meeting these manpower needs.

#### Basic Data for Planning

39. In this brief summary on basic data, we assert that our early experience with basic data for river basin planning will very likely be duplicated by many developing nations. Those who undertook the first comprehensive surveys in the United States had to contend with great gaps and serious inadequacies of basic physical data. Yet, some highly successful developments were undertaken in spite of these handicaps. Fortunately, the importance of systematic collection and analysis of basic physical and economic data has won increasing recognition in this country, so that our situation in this respect is much improved. In a sense, planners will always feel that the available data are not fully adequate for the task at hand (26).

40. Several suggestions flow from our experience with basic data for planning:

(a) Once the major gaps and inadequacies in basic physical and economic data have been identified, major efforts should be made to institute programs for the systematic and sustained collection and analysis of such data.

(b) Unless available data are very scanty, it is usually possible to do a

good deal of planning on a reconnaissance basis, to prepare framework plans that are useful as general guides to development.

(c) It is prudent, however, to avoid heavy commitments of investment in the face of grossly inadequate data. An expedient solution is to resort to construction of river development works in stages and to incorporate flexibility of use into such works, so that shifts in use can be made at moderate cost as required in the future.

#### Conclusions

41. This brief review of U.S. experience in river basin planning has revealed several significant implications of possible interest to developing countries. In recapitulation, the important points are:

(a) Goals and objectives for river basin development should be clearly stated by the top policy-makers at the outset of planning.

(b) Overall national projections of economic activity or targets for economic development should be established, and regional or local projections or targets should be derived from these as guides for the planners.

(c) The key to successful planning is the manner in which the planning task is set up: planning standards and criteria must flow from the overall objectives, and a methodology for optimization in terms of these standards must be developed.

(d) Benefit-cost analysis is a useful basic tool for formulating economically optimal plans, and it can be used to evaluate intangible effects as well as effects measured in monetary terms.

(e) Planning river basin development should be considered in the con-

text of total investment planning for all sectors of the economy.

(f) Even river basin planning agencies with very broad mandates and considerable autonomy will find it necessary to set up some type of coordinating arrangements with other central and local governmental units to take account of the diverse interests involved.

(g) A broad, interdisciplinary-team approach is essential to effective planning for comprehensive river basin development; definite provision should be made, in river basin plans, for providing the varied and specialized skills needed to carry out the plans.

(h) Programs for systematic and sustained collection and analysis of basic data are an integral part of the task of river basin planning; where data are seriously lacking, broad plans with provision for flexibility are preferred over plans in great detail.

42. In considering these points, it is well to note possible differences between the planning environment in the United States and in developing countries:

(a) In the United States, river basin development is still an important factor, but not necessarily a dominant one, in advancing the economic development of specific regions or of the country as a whole; whereas in developing countries, development of river basin re-

sources may be a key factor and may merit a large portion of the national effort for economic progress.

(b) In the United States, development has proceeded to a point where needs for improving water quality for many purposes, for enhancing fish and wildlife environment, and for developing recreation opportunities have come to be of equal and sometimes controlling significance in planning river basin developments; whereas in developing countries, the needs for basic economic development in agriculture or industry may warrant greater emphasis, initially at least, on such water uses as irrigation, hydropower, navigation, or flood control.

(c) In the United States it has been possible to place great reliance on market prices for computing development costs and benefits, because: (a) markets are highly developed for a great range of inputs and outputs, (b) outputs of commodities or services flowing from water development plans do not comprise so great a proportion of total output as to affect market prices significantly, and (c) constraints on foreign exchange have not been a significant factor. In developing countries, variations in these conditions should be considered in evaluating river basin developments.

#### REFERENCES

- (1) Goodrich, C., *Government Promotion of American Canals and Railroads, 1800-1890*, Columbia Univ. Press, New York (1960).
- (2) Hays, S. P., *Conservation and the Gospel of Efficiency*, Harvard Univ. Press, Cambridge, Mass. (1959).
- (3) A broad survey of the historical development of river basin planning is given in White, G. F., *A perspective of river basin development*, Law and Contemporary Problems, 22, No. 3, 157-187, Duke Univ. School of Law, Durham, N.C. (1957). See also Schad, T. M., *Perspective on national water resources planning*, Proceedings, No. 3188, American Society of Civil Engineers, New York (1962).

(4) A somewhat broader formulation of this concept is presented by White, *op. cit.*, 160-178.

(5) The classification here follows that in Maass, A. A., Hufschmidt, M. M., et al., *Design of Water-Resource Systems*, Chap. 1, Harvard Univ. Press, Cambridge, Mass. (1962).

(6) Clapp, G., *The TVA: An Approach to the Development of a Region*, Univ. of Chicago Press, Chicago (1955).

(7) McKinley, C., *Uncle Sam in the Pacific Northwest*, Univ. of California Press, Berkeley, Calif. (1952).

(8) Hart, H., *The Dark Missouri*, Univ. of Wisconsin Press, Madison, Wis. (1957); and U.S. Missouri Basin Survey Commission, *Missouri: Land and Water*, U.S. Govt. Print. Off., Wash., D.C. (1953).

(9) U.S. Army Corps of Engineers, *Report on the Comprehensive Survey of the Water Resources of the Delaware River Basin*, House Doc. 522, 87th Cong., U.S. Govt. Print. Off., Wash., D.C. (1962).

(10) *Policies, Standards, and Procedures in the Formulation, Evaluation, and Review of Plans for Use and Development of Water and Related Land Resources*, Senate Doc. 97, 87th Cong., U.S. Govt. Print. Off., Wash., D.C. (1962).

(11) Morgan, A. E., *The Miami Conservancy District*, McGraw-Hill Book Co., Inc., New York (1951); see also Woodward, S. M., *Hydraulics of the Miami Flood Control Project*, Miami Conservancy District Technical Reports, Part 7, 286-308, Dayton, Ohio (1920).

(12) No comprehensive analysis of these inventory surveys (commonly known in the United States as the "308" surveys) is available. A typical survey report—for the Columbia River and minor tributaries, completed in 1932—is published as House Doc. 103, 73d Cong., U.S. Govt. Print. Off., Wash., D.C. (1933).

(13) See Clapp, G., referred to in reference (6); also, Bowden, N. W., *Multiple Purpose Reservoir Operation*, Civil Engineering, 11, 291 and 337 (1941); Blee, C. E., *Multiple-Purpose Reservoir Operation of the Tennessee River System*, Civil Engineering, 15, 220 (1945); and Ackerman, E. A., R. E. Lewry, *Organization for water resources development in the United States, with particular reference to the Tennessee Valley Authority*, Proceedings of the Regional Technical Conference on Water Resources Development in Asia and the Far East (Flood Control Series No. 9), 439-445, U.N. Economic Commission for Asia and the Far East, Bangkok (1956).

(14) National Resources Planning Board, *Water Development Policies: Development of Resources and Stabilization of Employment in the United States*, House Doc. 142, 77th Cong., 371-400, U.S. Govt. Print. Off., Wash., D.C. (1941).

(15) Subcommittee on Benefits and Costs, Federal Inter-agency River Basin Committee, *Proposed Practices for Economic Analysis of River Basin Projects*, U.S. Govt. Print. Off., Wash., D.C. (1950); a revised version was published, under the same title, by the Subcommittee on Evaluation Standards, Inter-agency Committee on Water Resources, U.S. Govt. Print. Off., Wash., D.C. (1958).

(16) President's Water Resources Policy Commission, *A Water Policy for the American People*, U.S. Govt. Print. Off., Wash., D.C. (1950); Missouri Basin Survey Commission, reference (8); and U.S. Presidential Advisory Committee on Water

Resources Policy, *Water Resources Policy*, U.S. Govt. Print. Off., Wash., D.C. (1955).

(17) Foremost among these are: S. V. Ciriacy-Wantrup, E. O. Heady, M. M. Kelso, J. Margolis, and M. Regan.

(18) The major works are: Leopold, L., T. Maddock, Jr., *The Flood Control Controversy*, The Ronald Press Co., New York (1954); Eckstein, O., *Water-Resource Development: The Economics of Project Evaluation*, Harvard Univ. Press, Cambridge, Mass. (1958); McKean, R., *Efficiency in Government through Systems Analysis, with Emphasis on Water Resources Development*, John Wiley & Sons, New York (1958); Krutilla, J., O. Eckstein, *Multiple Purpose River Development: Studies in Applied Economic Analysis*, The Johns Hopkins Univ. Press, Baltimore, Md. (1958); Ackerman, E. A., and Löf, G., *Technology in American Water Development*, The Johns Hopkins Univ. Press, Baltimore, Md. (1959); Hirshleifer, J., J. C. De Haven, J. W. Milliman, *Water Supply; Economics, Technology, and Policy*, The Univ. of Chicago Press, Chicago (1960); Maass, A. A., Hufschmidt, M. M., et al., referred to in reference (5).

(19) *The Report of the U.S. Study Commission—Texas*, House Doc. 494, 87th Cong., U.S. Govt. Print. Off., Wash., D.C. (1962); U.S. Army Corps of Engineers, *Water Resource Development, Columbia River Basin*, House Doc. 403, 87th Cong., U.S. Govt. Print. Off., Wash., D.C. (1962); U.S. Army Corps of Engineers, *Potomac River Basin Report* (in preparation).

(20) See reference 9.

(21) Results of the first, basic-research stage are reported in Maass, A. A. and Hufschmidt, M. M., et al., referred to in reference 5.

(22) Congressional recognition of the need for comprehensive river-basin planning and for improvements in techniques of analysis has been given by a Senate Select Committee on National Water Resources in a recent appraisal of the Nation's water problems. See Senate Report No. 29, 87th Cong., 1st sess., U.S. Govt. Print. Off., Wash., D.C. (1961). The Committee issued a series of subsidiary reports, published as Committee Prints 1-32, 86th Cong. (1959-1960). These are listed on pages 74-75, and summarized on pages 78-130 of the Report.

(23) The literature on United States water resource organization is extensive. Good summaries of the problems and issues are: *Water Resources, Law and Contemporary Problems*, 22, No. 3, Duke Univ. School of Law, Durham, N.C. (1957); Fox, I. K. and Craine, L. E., *Organizational Arrangements for Water Development*, *Natural Resource Journal*, 2, 1-44, The Univ. of New Mexico School of Law, Albuquerque, N. Mex. (1962); Martin, R. C., et al., *River Basin Administration and the Delaware*, Syracuse Univ. Press, Syracuse, N.Y. (1960). See also Maass, A. A. and Hufschmidt, M. M., et al., referred to in reference (5) Chap. 15.

(24) Bloomfield, L. M., G. F. Fitzgerald, *Boundary Waters Problems of Canada and the United States*, The Carswell Co., Ltd., Toronto (1958).

(25) See *Utilization of Waters of the Colorado and Tijuana Rivers and of the Rio Grande*, Treaty between the United States and Mexico (February 3, 1944), and *Protocol* (November 14, 1944), U.S. Govt. Print. Off., Wash., D.C. (1946).

(26) The standard source on basic data for water planning in this country is: Langbein, W., W. G. Hoyt, *Water Facts for the Nation's Future*, The Ronald Press Co., New York (1959).

# Advances in Techniques of Ground Water Resources Development

DAVID K. TODD

*Professor of Civil Engineering, University of California, Berkeley, California*

## Abstract

1. As a result of recognition of the advantages of ground water resources, the rate of development of underground water supplies is steadily increasing. To facilitate investigation and development of ground water resources, many new techniques have become available in recent years. These are derived from a variety of advances in science and technology. For example, benefits have come from research on ground water flow, radioisotopes, computers, geophysical equipment, and aerial photographs.

2. For investigations of ground water resources, interpretation of aerial photographs has assisted in delineating areas of potential ground water supplies. Hydrobotanic studies can indicate locations and depths of ground water from vegetational types. Improved well logging techniques, including radioactive logs, furnish information on rock type, permeability, porosity, and salinity. Hydrogeologic maps provide ready means for summarizing extensive field data for general use. Improved drilling equipment has reduced the time for drilling water wells to often only a few hours. The availability of tritium provides a convenient new tool for tracing the movement of water underground. In addition,

measurements of naturally occurring tritium in ground water enable estimates to be made of the length of time that water has been in storage underground.

3. Several research efforts in ground water hydrology in recent years have been directed toward the augmentation and protection of ground water resources. Field studies in connection with projects in California have led to improved methods of artificially recharging water into the ground and of protecting aquifers against sea water intrusion. Management studies of ground water reservoirs have been directed toward the most economic long-time use of ground water in conjunction with variable surface water resources. Computers have enabled determinations to be made of the time and space distributions of ground water for decades into the future.

4. Recently, major investigational and developmental programs of ground water resources have been undertaken in several Asian countries. These activities suggest that the scientific advances described will soon find application on a world-wide basis. United Nations organizations can assist in education and dissemination of information for the benefit of developing nations.

## Introduction

5. Ground water represents a major water supply source throughout the world. Historically the use of shallow dug wells for domestic and irrigation supplies dates from ancient times. Within recent decades, however, technological advances have enabled ground water at great depths to be utilized. These advances include new methods for investigating ground water, new drilling techniques for water-well construction, and new pumps for lifting water (1). Thus, larger and more dependable water supplies are now available in arid and semi-arid parts of the world.

6. There are several advantages to development of ground water resources. Ground water reservoirs are available without cost and provide a natural distribution system. Further, ground waters are free from contamination, are not subject to evapotranspiration losses, and possess nearly uniform temperatures. Underground water storage, therefore, with proper development and management can provide efficient and economic water supplies (2).

7. The purpose of this paper is to describe a few of the recent techniques for developing and managing ground water resources. Emphasis will be placed upon practical applications and examples from field experiences. References are included to facilitate more detailed study of specific topics.

## Ground Water Basin Management

8. The concept of ground water basin management (3) presupposes that a ground water reservoir will be controlled in terms of inputs and outputs of water. First, this implies some basin-wide type of control over pumping in order to in-

sure that extraction of ground water from the basin approximates the average annual replenishment to the basin. Second, control must be exercised over the areal pattern of extraction or recharge. And finally, legal control is involved in that prescribed water rights of users are established. In the past, most ground water basin management has been on a trial-and-error basis. Thus, ground water levels were depressed by excessive pumping, then reduced in order to allow them to rise, and finally depressed again by subsequent pumping. Unfortunately, ground water basins are three-dimensional and nonhomogeneous. It is often difficult to ascertain on an annual basis the amount of water that can be removed or recharged simply by observation of ground water level. A ground water reservoir is entirely analogous to a surface water reservoir; it is useless if the level is maintained at the top of the dam at all times. On the other hand, if this water is stored and released so that fluctuations in water levels occur on an annual basis, maximum benefits in terms of water supply, power, flood control, and recreational benefits can be achieved simultaneously. The same applies to ground water reservoirs. These must be pumped during periods of water need and then recharged during periods when needs are less and additional supplies are available from other sources.

9. Ideally, ground water reservoirs should be managed in conjunction with surface water supplies. The interrelation is often referred to as conjunctive use. Essentially, conjunctive use means that ground water reservoirs will be pumped during periods when surface water supplies are limited. At other times, when additional surface water supplies are available, ground water reservoirs will be

pumped less or not at all and will be recharged both naturally and artificially. This combined water supply source system usually provides a larger, firmer and more economic water supply than would be available from either source individually. Operationally, conjunctive use requires that the surface and ground water resources be properly managed in order to have adequate water supplies at all times. It must also be recognized that ground water levels will fluctuate both seasonally and over a period of years. For example, during an extended drought running for a period of several years, surface water supplies would be limited so that ground water pumping would be at a maximum. Following this, however, in a period of several wet years, ground water levels will have an opportunity to recover.

10. An important new tool for analysis of ground water basin management is the electronic analog computer. This instrument has recently been put to work in studies of large, complex, ground water basins. Development and application of techniques suggested by this computer can materially assist water resource managers in preventing ground water basin exhaustion and in providing for the most beneficial pattern of extraction of ground water.

11. An excellent example of the application of the analog computer is the study of ground water conditions in Southern California. Recent work by the California Department of Water Resources has indicated that this tool is a valuable means for preparing ground water basin operational programs for future decades (4). Studies have been carried out on basins which have been subject to withdrawals of water exceeding combined natural and artificial replenish-

ment. As a result, a state of overdraft now exists.

12. Use of an analog computer for ground water studies is based upon the fact that laws governing the flow of electricity are similar to those for the flow of ground water. This analogy becomes the basis, therefore, for solving complex mathematical equations involved in evaluating the dynamics of a ground water basin flow system. The physical characteristics of a ground water basin can be represented by various electronic components, making the computer a basin model. For example, the permeability of an aquifer is analogous to the reciprocal of the resistance, the specific yield or storage coefficient of the basin is analogous to the capacitance, and the difference in hydraulic head of ground water levels is analogous to the voltage drop in an electrical current.

13. The general continuity equation of ground water flow, namely that inflow minus outflow equals change in storage, and Darcy's law governing ground water flow are the basic relations involved. Darcy's law is similar to Ohm's law governing the flow of electricity. Problems of ground water storage and movement are solved by measuring quantities on a model of the ground water basin constructed of electronic components. Two types of computers are available for this purpose. The passive element analog computer is the simplest one. It involves a network of resistors representing the hydraulic conductivity and capacitors representing the storage coefficient. The other type, the active element computer, replaces the simple components with electronic amplifiers which react in essentially the same manner but are readily controllable, very stable, and highly accurate. Each type

of computer requires an array of supplemental equipment of a complex nature to provide input and initial operating conditions and to measure outputs.

14. The active-element computer was selected for studies of the Coastal Plain of Los Angeles County by the California Department of Water Resources. Basic data necessary as inputs to the computer included boundaries of the ground water basin, geologic structures within the ground water basin that affect ground water movement, and physical characteristics such as hydraulic conductivities and storage coefficients. The Coastal Plain of Los Angeles County has an area of about 480 square miles. Study of some 5 thousand drillers' logs of water and oil wells throughout the area served as the basis for delineating the aquifers. All water-bearing sediments were assigned values of specific yield and hydraulic conductivity. As a simplification it was necessary to assume that neither specific yields nor hydraulic conductivities changed with time or with ground level fluctuations. With this given information the study area was divided into 82 unit areas, each represented by a control node point, or junction point, in the analog model. Locations of nodes were based on geologic replenishment, extraction, hydraulic conductivity, specific yield, and ground water level data. Concentrations of nodes were in areas of rapid change in physical conditions in order to more accurately predict these changes. The general equation of ground water movement was then solved by the electrical interconnection of these nodes and by the computer formulated on this plan to solve the 82 simultaneous differential equations with changing conditions of inflow and outflow.

15. Historical data on replenishment

of and extraction from the aquifers in the basin were applied to the analog model to determine whether the computer could actually represent the physical conditions of the aquifers and to measure the ground water flow throughout the study area. For these tests, data for an 11-year period were readily available and were given as inputs to the computer. Initial elevations of ground water levels were set on the computer using function generators to vary the current flow for net extraction at each node point in the analog model. The variation in voltage, or ground water level, with time was read from the model. This variation was compared with historical fluctuations. After some adjustment of the physical factors in specific areas, a representative model was obtained, that is, one that demonstrated water level changes throughout the basin similar to historical changes.

16. After the test work on the analog model it was then applied to study problems of managing the ground water basin under future conditions. Changes could be made in rates and locations of extraction and replenishment. Output data from the model indicated ground water level elevation changes with time due to these input variations. This information indicated areas in which extractions should be limited, maximum rates of artificial recharge, and where recharge should be accomplished. The computer also produced a variety of useful information. It was found, for example, that reasonable amounts of recharge in the upper areas of the Coastal Plain would not be effective in halting sea water intrusion at the coast 22 miles away. It was also ascertained that, because of the physical characteristics of the basin, an adjustment period after any

change in input or output would require more than 100 years before an equilibrium condition would be reached. The information derived from the model served as a basis for preparation of alternative plans of operation which can be coordinated with available imported supplemental sources of water to reach optimum utilization of the resources of this basin. Thus, conjunctive use of local ground water sources and imported surface water supplies can only be accomplished in an optimum manner if this basin is operated under a planned management scheme. The analog computer not only assisted in these investigations but also will aid in making future management decisions required for operation of the basin.

17. Current developments in the upper portion of the Indus River Basin in West Pakistan provide a good illustration of conjunctive use of surface and ground water sources. Large irrigation areas have been developed by a network of canals over the past 75 years. Seepage from these canals, however, has raised the ground water level from a distance of roughly 75 feet below ground surface up to an average of less than 10 feet below ground surface. As a result, at the present time, a large portion of the area is subject to waterlogging and salinization. Areas available for agricultural production are being decreased by the detrimental influences at a rate of approximately 100 thousand acres per year. In order to alleviate the situation it has been proposed to construct a grid of tube wells over the irrigated lands. The soil is quite permeable and will yield large quantities of water to wells approximately 200 feet deep. The pumped water will be discharged into existing irrigation canals to supplement the water

available for irrigated agriculture. The tube wells, therefore, will serve a double purpose. First, they will assist in lowering the water table by the removal of excessive water in the irrigated areas. Second, these wells will provide additional water for irrigated land so that a downward movement of water through the root zone can be established to leach accumulated salts. The magnitude of pumping can be varied depending upon local conditions, especially rainfall and existing ground water levels. Initially, large ground water pumping is desirable to accelerate the lowering of the high water table. After the water table has fallen from 10 to 20 feet, however, there is no need to lower the water table from the standpoint of its impairment upon agricultural production. Any subsequent lowering would increase the cost of pumping; therefore, the magnitude of pumping should be restricted so that the ground water level will fluctuate seasonally and secularly in a range governed by the recharge to ground water. Ultimately, this recirculation system will cause an increase in salt content in the ground water. However, as the salt content tends to build up, increasing amounts of water can be pumped to waste in the rivers and discharged into the ocean. In this manner the system can be operated for an indefinite period without causing high salinity which would endanger irrigated agriculture.

#### **Aerial Photographs**

18. As the occurrence of ground water is related to terrain characteristics, proper interpretation of aerial photographs is often a valuable means of identifying ground water conditions. Vegetation, land form and use, drainage patterns, erosion, color, and special ground fea-

tures are apparent on air photographs and indicate subsurface conditions. From studies of air-photo mosaic maps and of stereoscopic photo pairs, drainage and soil maps can be prepared.

19. A recent study in Indiana (5) indicated that air-photo interpretation could be employed to develop a ground water prediction map. An area was divided into zones of good, fair, and poor water yield based upon air-photo analysis. The classification indicated areas yielding more than 200 gallons per minute as good ground water areas, areas yielding 50 to 200 gallons per minute as fair ground water areas, and those yielding less than 50 gallons per minute as poor areas. Examination of well data subsequently confirmed the analysis.

20. The preparation of hydrogeologic maps is also greatly facilitated from aerial photographs. The delineation of the most and least promising areas for ground water supplies can be indicated on such maps. These maps aid in selecting test drilling sites, in reducing costs of ground water investigations, and in assisting in locating industrial plants requiring large ground water supplies.

21. The art of air-photo interpretation has progressed to such a point that investigations of vegetation are often useful indicators of ground water. It is possible, under certain conditions, to determine from air photos alone where water may be obtained in arid and semi-arid regions, the minimum amount that is perennially available, and whether the water is of good chemical quality. Studies by Mann (6) in the Southern California desert showed that the interpretation is based on the premise that water of good quality forced to the surface in dry regions will have been pre-empted by phreatophytes and that the

amount of water available will govern the size of the vegetated area. A familiarity with the general region and the local plant types may be necessary to interpret with maximum effectiveness. Although such hydrobotanic investigations need subsequent field investigation, it is apparent that this rapid means for identifying potential ground water sources can represent a vast savings where new water supplies are needed in large relatively undeveloped areas.

22. Many times the geologic conditions in a particular area, as well as the associated hydrobotanic conditions, will reveal ground water situations which can be adequately analyzed from aerial photographs alone. For example, a fault acting as a conduit will show springs where it intersects the axes of the valley. A small spring produces a spot of phreatophytes, whereas a larger spring will show a line of phreatophytes extending downstream. A fault acting as a barrier is shown by a patch of phreatophytes sharply limited by the fault on the down-slope side and often a strip of dense vegetation marking the overflow. Areas of constriction in dry alluvial channels are often marked by large quantities of rising water. In closed desert basins, alluvial fans often discharge large quantities of water. Phreatophytes arranged like the spokes of a wheel around the base of an alluvial fan may indicate where ground water is rising to the surface. Indications of water quality depend upon correlations between water salinity and plant species. Although some work has been done in this field, further investigations are needed to define these relations before specific statements can be made about ground water salinity from aerial photographs alone.

### Sea Water Intrusion

23. A common problem in ground water formations located near the coast is that of sea water intrusion. This may be defined as an increase in salinity of ground water over that normally occurring at a given location in an aquifer. It is usually the result of acts of man, primarily from concentrated extractions of ground water in localized areas. The problem is well-known along the coasts of the United States; in particular it has affected the coast lines of Long Island, Florida, Texas, and California (7). Intrusion is also known along the coasts of Europe, Israel, and Japan.

24. In order to control sea-water intrusion, five methods have been suggested: (a) Reduction and/or rearrangement of pattern of pumping draft, (b) Direct recharge, (c) Development of the pumping trough adjacent to the coast, (d) Maintenance of a pressure ridge above sea level along the coast, and (e) Construction of artificial subsurface barriers. Although reduction of pumping is an obvious method of control, in many locations legal restrictions and property rights prohibit government agencies from regulating pumping from privately-owned wells. Therefore, more costly procedures are necessary involving one or more of the other methods in order to control intrusion.

25. In recent years a comprehensive field test of the pressure ridge method has been conducted in Los Angeles County, California (8). The pressure ridge method involves building up a fresh water pressure ridge adjacent to the coast by means of a line of recharge wells. The piezometric surface along the ridge is raised sufficiently high to repel sea water, causing the recharged water to flow both seaward and landward. By

proper control of the height of the ridge, the amount of recharge water wasted to the ocean can be minimized. The ridge consists of a series of peaks at each well with saddles in between. The ridge should be located inland from the saline front to avoid advancing sea water further inland. This method has the advantage of not restricting the usual ground water storage capacity but has the disadvantages of high initial and operating costs and the need for supplemental water.

26. In the Los Angeles test a confined aquifer was selected for study that had been badly degraded by sea water. A line of recharge wells was located parallel to and about 2,000 feet inland from the ocean. The piezometric surface along the well line was 6 to 12 feet below sea level and the ground water contained 16,000 ppm chloride. Nine gravel-packed recharge wells were constructed at intervals of 500 feet to form a line 4,000 feet long. Numerous small observation wells were also drilled in the vicinity. Injection into the recharge wells with treated fresh water was begun in 1953. Immediately after recharge had begun, the ridge pressure began to develop and at the present time the ridge is still successfully being operated and maintained. The combined recharge rate for the eight wells is about 5 cfs. The amount of water flowing toward the ocean is approximately 5 percent of the total recharge water, while the remaining 95 percent flows landward for subsequent replenishment to the ground water basin. Chlorination of the recharge water has been found necessary to prevent clogging of the wells by bacterial slime. Chloride content of ground water near the recharge well line dropped rapidly to that of the fresh water con-

tent after the injection had become effective.

27. This investigation demonstrated the technical feasibility of maintaining a recharge line parallel to the coast for control of sea water intrusion. Subsequently economic justification of the barrier for protecting the entire ground water basin indicated that the safe yield of the basin was of such importance that the line was worth extending in both directions in order to protect the entire coastal plain of Los Angeles County. At the present time the recharge well-line is being extended and additional studies are underway for new recharge lines in nearby areas.

#### **Artificial Recharge**

28. Artificial recharge may be defined as the increasing of natural infiltration of precipitation or surface water into underground formations by some method of construction, by spreading of water, or by artificially changing natural conditions. The technique is well known in the United States and in Europe(9). In recent years considerable attention has been focused upon the importance of increasing rates of artificial recharge in order to provide larger ground water supplies and also as a means of management of ground water basins.

29. Water may be recharged underground by a variety of methods. The surface methods come under the general heading of water spreading. Water spreading may be classified as flooding, basin, ditch or furrow, natural channel, and irrigation types. In the flooding method, water is allowed to spread evenly over large, flat areas. The thin sheet of water spreads at a minimum velocity without disturbing vegetation and soil.

Although the cost is minimal for this method of artificial recharge, control of the water is difficult and maximum efficiencies are difficult to obtain. More common is the basin method in which water is released into shallow basins formed by excavation or construction of dikes or small dams. Horizontal dimensions are relatively large with depths being of only a few feet. Typically, systems of basins are fed from a nearby surface-water source, allowing one basin to discharge into an adjacent lower basin after it becomes full. The basin configuration can be suited to the local topography so that a system involving many basins can be constructed near flat flood plain areas bordering surface water supplies. From the lowest basin, excess water is returned to the stream channel. In California, where recharge artificially has been practiced to the maximum extent in the United States, basins have been constructed in abandoned stream channels. Usually basins will permit water contact with 75 percent to 80 percent of the gross area involved. This method, because of its high efficiency and easy maintenance, represents the favored method of artificial recharge by spreading. The ditch or furrow method consists of construction of flat ditches paralleling the land contours. Gradients in the ditches must usually be sufficient to carry suspended material through the system; deposition of fine-grained material tends to clog soil surface openings. The method is most useful for irregular terrain where large, relatively level areas are not available for basin construction. The natural channel method consists of developing channel barriers to form basins, the primary purpose being to extend the time and area over which water is in contact with the stream channel. Small dikes may be constructed

in the stream of concrete, rock, or simply of the channel material. Quite often these are of a temporary nature, requiring only bulldozer work, and may be washed out during the next high water period. Finally, irrigation method consists of spreading excess water on irrigated land. This involves no additional cost or land for the spreading system. The main requirements are availability of water and periods of application in which water will not affect the existing crops or when crops are not being grown.

30. In a typical water spreading operation the initial recharge rate is high and then decreases rapidly with time to a low minimum value. As the recharge rate decreases, the efficiency of the operation, and therefore the cost of recharging, increases proportionately. Considerable study has been given in recent years to field techniques for increasing the rate of water spreading. Studies by the U.S. Agricultural Research Service have indicated that recharge rates are related to the mean particle size of the soil in which the spreading is occurring. Efforts have been made to increase the soil pore openings for water passage by the addition of organic matter and chemicals as well as growing vegetation on the spreading area. Certain procedures, such as the spreading of cotton gin trash and the growing of Bermuda grass, have indicated that increased intake rates are possible. Another effective means for controlling the rate of artificial recharge involves alternate wetting and drying of the soil. It has been found that prolonged wetting of a soil exposed to the atmosphere will produce microbial growths which tend to clog the soil surface. Drying kills these growths and reopens the soil pores. Thus, in order to maintain a high recharge rate intermit-

tent application of water may prove essential.

31. Another means for increasing artificial recharge is by detonation of nuclear explosives to improve subsurface conditions for artificial recharge. Two applications are possible in this particular approach. For the disposal of waste liquids, such as radioactive materials, brine, and industrial chemicals, it has been suggested that nuclear explosives could create large underground cavities into which these wastes could be disposed. These cavities would in turn be connected to deep permeable formations such as abandoned petroleum reservoirs well below any existing ground water sources. A second application is that of fracturing near-surface impermeable zones and creation of shallow craters into which water could be disposed for subsequent infiltration and percolation into the ground. Field and laboratory research on this subject to date looks promising; in a few years perhaps it will be possible to apply this tool for beneficial purposes to supplement ground water supplies.

#### **Radioisotopes**

32. The availability of radioisotopes in recent years has opened up new possibilities for investigation of ground water resources. An excellent example is the use of tritium for studying the flow and age of ground water. Molecules of water containing tritium, an isotope of hydrogen, act in the same manner as water molecules. Therefore, tritium serves as an excellent tracer, which can be detected in very low concentration. In addition, because tritium produced in the atmosphere by cosmic radiation and by thermonuclear explosions is found in rainfall, it is possible by tritium meas-

urements of ground water samples to ascertain how long water has been underground.

33. The U.S. Geological Survey recently completed a study in New Jersey (10) of the natural tritium in a sandy aquifer adjoining a river. Results showed that concentrations decreased from 120 tritium units at 0.6 meter below ground surface to 1 tritium unit at a depth of 30 meters. This gradient revealed that water older than 25 years existed at the lower level, while water less than 8 months underground existed at the water table. This confirmed a hypothesis long recognized from hydraulic studies that ground water occurs and moves in layers with the youngest water in the upper layers moving the fastest. To complete the picture, measurements of the tritium content of the river, whose flow was essentially all base flow from ground water, showed concentrations almost exactly equal to the uppermost ground water values.

34. Injections of tritium into ground water through canals and wells enable ground water flow to be traced. Recent field tests have confirmed that tritium tracer can be used to ascertain canal seepage rates (11). The procedures in working with tritium as a tracer are identical to those for salts and dyes as tracers. Because tritium can be measured in minute concentrations, there is a greater possibility of following tritium after long distances of flow than with other previously available tracers.

35. The availability of radioisotopes has also produced neutron probes. These probes are recent developments now available commercially for the measurement of moisture content in soils above the water table. Neutrons, being particles having no charge and having a mass about equal

to that of the hydrogen atom, are slowed by collisions with hydrogen whereas with other materials of much larger masses the collisions are essentially elastic. Collisions with hydrogen, however, reduce the rate of neutron travel up to one-half, thus fast neutrons become slow neutrons by contact with material containing hydrogen. Underground, this is chiefly water. Therefore, measurements of slow neutrons give a measure of moisture content. The neutron probe is contained in a cylinder which is lowered in a small observation hole in the ground. Radiation is emitted from a radium beryllium source of fast neutrons. The detector is a foil of stable indium-115 which by bombardment by slow neutrons becomes indium-116. This radioactive material can then be measured by means of a Geiger counter. The procedure involves lowering the neutron probe into the hole and observing the measure of radioactivity at given levels.

36. Important applications for neutron probes include measurement of infiltration rates from applied water and from precipitation. An especially useful benefit is the measurement of need for irrigation by determining critical soil-moisture levels in the root zone. Depths of rainfall penetration and effects of nonhomogeneous layers can also be ascertained easily for the first time.

### Well-Logging

37. Well-logging is the investigation of subsurface conditions from wells which have been drilled into the ground. Methods of logging are numerous and in recent years improved techniques and new types of logging have extended the possibilities for investigating subsurface conditions. Electric logs which involve the measurement of resistivity of the earth

and potentials within the earth's crust have become standard techniques for studying underground formations. Recently these techniques have been refined and improved so that it is now possible to ascertain more about ground water than was previously possible.

38. Radioactive logging can be carried out in cased or uncased holes. Two types of logging are recognized (12). The first is gamma-ray logging which measures the vertical variations of natural gamma rays in the earth. These rays originate from disintegrations of uranium, thorium, and potassium. The relative radioactivity can be used as a rough method of identifying formations and is best done with other supplemental information. Applications of gamma-ray logging include correlation studies and identifications of lithology, formation depths, and bed thicknesses. The second type of radioactive logging is neutron logging. Here neutrons released from a source within the hole can be used for identifying lithology, porosity, fluid type, and formation depths and thickness. In practice it is common to carry out the neutron log in conjunction with the gamma-ray log. Most radioactive logging has been done in the petroleum industry; application of this from oil wells to water wells is now in an early stage.

39. Other logging techniques now available include current meter logs for measurement of the vertical flow of water inside wells. Often such measurements are indicative of sources of water movement from one aquifer to another. Such flows are important in establishing recharge to confined formations and migrations of saline water into fresh water aquifers. Other logging techniques include caliper logs, which can be used to determine diameters of holes.

Such information indicates formations which are subject to caving and in other instances can be used to locate well casings or drilling tools. With the availability of television, TV logs are now possible for the first time. In this system, portable television cameras and lights of special design are lowered into water wells. By means of a closed circuit system, the interior of the well casing can be studied in detail. Such studies assist in locating casing breaks and sources of contaminating water, in studying the condition of wells, and in ascertaining positions of lost drilling tools.

### Well Drilling

40. The advent of rapid means of drilling deep holes has done much to stimulate ground water development. Development of the rotary drilling process in the petroleum industry was rapidly copied for ground-water purposes (13). The hydraulic rotary method operates by hollow rotating bit cutting the rock while a mixture of clay and water, or drilling mud, is forced down through the drill rod to carry the cuttings upward in the rising mud. The mud serves the additional purpose of stabilizing the wall of the well, preventing caving, and making casing unnecessary. After the drilling is completed, perforated casing is lowered into the hole and the clay lining is washed from the wall by injecting water down the drill rod. Wells can be constructed to depths of about 2,000 feet by this method and even deeper if it is worthwhile from a hydrologic standpoint. Diameters up to 18 inches are common; with reamers diameters twice as large are possible.

41. The reverse rotary method uses water instead of mud and operates as a suction dredging method (14). Cuttings

are removed by a rotating suction pipe, while the hydrostatic pressure of water within the hole acts against fine-grained deposits to support the wall. The method is especially useful for large-diameter wells in unconsolidated materials.

42. Direct rotary drilling using air instead of mud or water to remove cuttings is a rapid and convenient method for small-diameter holes in consolidated and unconsolidated formations (15). The latest drilling development is a rapid procedure for drilling in hard rock formations. It involves a rotary-percussion combination with air (16). Above the rotating bit an air hammer delivers 600 to 1,000 blows per minute to the bottom of the hole. Penetration rates by this method of up to 1 foot per minute in hard rock have been reported. Thus, we are rapidly reaching the stage in which water wells can be drilled within a matter of a few hours rather than a few days or weeks as was common only a decade ago.

43. As an illustration, some 18 hundred new irrigation wells have recently been drilled in the Indus River Basin of West Pakistan. These were 18 to 24 inches in diameter and were drilled to an average depth of 250 feet. Drilling time for most of these was less than 24 hours by the reverse rotary technique.

### **Education and Manpower in Hydrology**

44. With the advances in technology of ground water resources development a great need has developed for competent young men to carry out investigational and developmental work in ground water. The problem is so acute that universities throughout the world need to give attention to educational programs and facilities which will enable men with back-

grounds in the science of hydrology to be produced. Education requires time; therefore attention needs to be given as soon as possible to means for providing educational facilities and trained manpower. A variety of procedures are possible and these will be commented upon briefly.

45. The availability of fellowships for studies at universities throughout the world for students in the field of hydrology would do much to encourage interest and education in hydrology. At the same time exchange of faculties from one country to another would be helpful. Men experienced in hydrology and in ground water development could lecture and supervise research at other universities which have not had personnel and facilities before in this field.

46. An effective intermediate means for improving the educational background of existing personnel in developing nations is by means of seminars and short courses. These have long been held by the U.S. Geological Survey as a means of indoctrination and instruction in ground water hydrology for new personnel. International seminars and conferences, such as those which have been sponsored in recent years by UNESCO and ECAFE, are effective means for bringing key personnel from developing nations together so that they will have an opportunity to become familiar with latest techniques in the field. A continuation of these programs and other forms of international cooperation in the field of ground water hydrology will do much to develop competent manpower and the benefits of adequate water supplies for mankind throughout the world.\*

\*The reader is referred to the paper, Education in Hydrology, by J. W. Harshbarger, in this volume.

## REFERENCES

- (1) Todd, D. K., *Ground Water Hydrology*, John Wiley and Sons, 336 pp., New York (1959).
- (2) *Large-Scale Ground Water Development*, Water Resources Development Center, United Nations, 84 pp., New York (1960).
- (3) Committee on Ground Water, *Ground Water Basin Management*, Manual of Engineering Practice No. 40, American Society of Civil Engineers, 160 pp., New York (1961).
- (4) Fowler, L. C., *Electronic Analog Computers and Ground Water Basin Management*, Proceedings 1961 Biennial Conference on Ground Water Recharge (L. Schiff, editor), Agricultural Research Service, Fresno, Calif. (1962).
- (5) Howe, R. H., H. R. Wilke, D. E. Bloodgood, *Application of air photo interpretation in the location of ground water*, J. American Water Works Assoc., 48, pp. 1380-1390, New York (1956).
- (6) Mann, J. F., Jr., *Estimating quantity and quality of ground water in dry regions using airphotos*, Publ. No. 44, General Assembly of Toronto, International Association of Scientific Hydrology, pp. 125-134, Gentbrugge, Belgium (1958).
- (7) Todd, D. K., *Salt Water Intrusion of Coastal Aquifers in the United States*, Publ. No. 52, Assembly of Helsinki 1960, International Association of Scientific Hydrology, pp. 452-461, Gentbrugge, Belgium (1961).
- (8) James, L. B., et al., *Sea-Water Intrusion in California*, Bulletin No. 63, California Department of Water Resources, 91 pp., Sacramento (1958).
- (9) Todd, D. K., *Annotated Bibliography on Artificial Recharge of Ground Water Through 1954*, U.S. Geological Survey Water-Supply Paper 1477, 115 pp., Washington, D.C. (1959).
- (10) Carlston, C. W., L. L. Thatcher, E. C. Rhodehamel, *Tritium as a Hydrologic Tool—The Wharton Tract Study*, Publ. No. 52, Assembly of Helsinki 1960, International Association of Scientific Hydrology, pp. 503-512, Gentbrugge, Belgium (1961).
- (11) Kaufman, W. J., D. K. Todd, *Application of tritium tracer to canal seepage measurements*, Tritium in the Physical and Biological Sciences, I, International Atomic Energy Agency, pp. 83-94, Vienna (1962).
- (12) Jones, P. H., H. E. Skibitzke, *Subsurface Geophysical Methods in Ground-Water Hydrology*, Advances in Geophysics (H. E. Landsberg, editor), 3, Academic Press, pp. 241-300, New York (1956).
- (13) *Wells*, Technical Manual No. 5-297, U.S. Department of the Army, 264 pp., Washington, D.C. (1957).
- (14) Gossett, O. C., *Reverse-circulation rotary drilling*, Water Well Journal, 12, 3, pp. 6-7, 22, 48, Urbana, Ill. (1958).
- (15) Yoeman, R. A., *Direct Rotary Air Drilling*, Water Well Journal, 12, 7, pp. 12, 32, 34, Urbana, Ill. (1958).
- (16) Yellig, E. J., *Down-the-Hole Air Percussion Drilling*, Water Well Journal, 12, no. 5, pp. 8, 22, 24, 27-28, 30, Urbana, Ill. (1958).

# Exploration for Ground Water, Northeast Thailand, 1952-62

HOWARD F. HAWORTH

*Ground Water Hydrologist, U.S. Operations Mission, Thailand*

1. Dependable supplies of water from the ground, developed by wells, would greatly benefit local communities over much of Thailand. Rainfall throughout the country is strongly seasonal, and long dry periods of 5 to 7 months each year bring hardship. Many small streams, springs, ponds, and dug wells become dry or nearly dry, and people living outside the major cities often have inadequate water for even domestic needs, health conditions become serious, domestic animals weaken, and in some instances families and their livestock are forced temporarily to other localities where water is available.

2. Some areas of the country are generally worse off than others, particularly the 15 Changwats in northeastern Thailand, an area commonly called the Khorat Plateau, comprising some 170,226 square kilometers (65,707 sq. miles), 33 percent of the total land area of Thailand. In this vast region live one-third of the country's population, almost 9 million persons. The area has few permanent streams other than the Mekong River which bounds it on the north and the east; the Mun and Chi rivers and their tributaries which wind across the southern two thirds of the area; and the Songkhram River in the small northern

basin. During the dry months even these major rivers are shallow and sluggish throughout much of their courses.

3. Many early attempts to obtain potable water from drilled wells in the Khorat Plateau had been unsuccessful. During 1905-1906, the Bureau of Mines drilled at Khorat to a depth of about 1,000 feet, but all water encountered was salty. In 1952, the Thai State Railway, in a test well at their Khorat Railway yards of a depth of 500 feet, again encountered only salty water. Attempts made in recent years to drill usable wells in the Khorat region also proved unsuccessful.

4. There are only a few private drilling contractors with modern equipment in Thailand, who work largely in the Bangkok area, and their equipment is not suitable for drilling conditions outside the central plains and other small, alluvial areas. There are a great many hand-operated Chinese rigs in use in various parts of Thailand, particularly in the central and northern areas. These have been important in partly filling the demand for wells, but they are limited to drilling wells of 4 inches diameter, to depths of approximately 400 feet in relatively unconsolidated formations, and are not suited to drilling in the shales, sand-

stones, and siltstones commonly encountered in the Khorat Plateau or the sandstones, limestone, slate, shales, and igneous rocks adjacent to the area.

5. A decade ago, in the early 1950's, efforts began to develop ground water in this region under cooperative programs of the Thai Government and the U.S. aid missions. The Ministry of Public Health purchased auger drills, mounted on jeeps, and in 1952-54, 374 wells were bored, primarily to secure drinking water. Results were less satisfactory than had been anticipated, primarily because the auger drills were placed in operation without assignment of instructors to train drilling personnel, and because of over-concentration of drilling in relatively small areas. It also became apparent during the early phase of this program that geologic conditions were generally too difficult for these auger drills. If production wells were to be drilled in the shales, siltstones and sandstones which predominate in the area, heavier drilling rigs would be required.

6. In 1953, interest began also in drilling irrigation wells. It was decided to consolidate drilling operations for these several purposes, and a special 3-month preliminary study was made in 1954 by Mr. P. E. LaMoreaux of the U.S. Geological Survey in collaboration with Thai geologists and engineers of the Royal Department of Mines, the Department of Health, the Royal Irrigation Department, and technical advisors from the United States Operations Mission to Thailand.

7. A Thai Government Ground Water Committee was established under the Chairmanship of the Director General, Royal Department of Mines, for the purpose of coordinating data, discussing the water supply needs of various agencies

interested in the area, and formulating development plans as work progressed.

### **Consolidated Drilling Program**

8. In order to lay a good basis for future development of the ground-water resources of the region, an exploration project was set up to survey and evaluate all possible sources before development began. Administration and field investigations were assigned to the Geological Survey Division, Royal Department of Mines, Ministry of Industry. The Sanitary Engineering Division, Department of Health, Ministry of Public Health, and the Royal Irrigation Department, Ministry of Agriculture, were to use four rotary rigs for exploratory drilling.

9. The project, which was jointly financed by the United States and Thai Government funds, was intended to provide the basic geologic and hydrological information needed to determine the ground water resources potential. It also provided for essential training of Thai personnel for future ground water development.

10. The exploration wells were to be widely distributed and of depths up to 1500 feet, so as to test the rocks at various depths in all parts of the Khorat region.

11. The work of evaluation could have been done more quickly and at less cost if small-diameter test wells had been drilled for hydrologic information only and not completed as production wells. However, in order to alleviate the water needs of the people as soon as possible and to get maximum benefits from the project, all test wells were to be developed as production wells wherever usable water of sufficient quantity was encountered.

12. A water quality laboratory was established in the Geological Survey to make chemical analyses of water from wells drilled under the project, and from existing dug wells, ponds, streams, springs, and reservoirs within the area. Such data with other studies would help to outline areas of potable water from both shallow water bearing beds and deeper potential artesian aquifers.

### Results of the Exploration Project

13. Drilling started in November 1955. By the end of June 1962, 678 exploration wells were completed in Northeast Thailand. Of this total, 450 wells (66 percent) produce water of suitable quality, 65 wells (10 percent) produce brackish water which is acceptable for some uses, 119 wells (18 percent) were abandoned because of salt, and 44 wells (6 percent) were abandoned as dry holes or because of mechanical difficulties.

14. It is now possible to outline the general areas where drilled wells most likely will provide water of usable quality. Owing to the wide coverage of the project, areas can be outlined where less than 15 percent of the wells drilled may be expected to provide satisfactory water. (These areas are shown on figure I.) The limits of the areas were established by studying logs of 678 drilled wells; 374 auger wells; checking dug wells; review of some 2,600 analyses of waters from drilled wells, dug wells, streams, ponds, reservoirs, and springs within the area; and correlating this work with geologic studies in the area (figure II).

15. Water quality for the area as a whole has proved to be much better than the initial work in the area had indicated. Success has been due in part to the fact that wells have been drilled in all parts of

the area, to better drilling practices, to the sealing off of unsatisfactory water in some instances, and to the better understanding given by geologic and hydrological studies.

### Difficulties Encountered

16. The presence of salt formations through much of the area made extreme care in drilling necessary. Other impediments during earlier stages were insufficient basic geological information, the short supply of personnel qualified to operate drilling equipment, and shortage of spare parts and supplies. The inadequate road network in the area inhibited progress, especially during the later part of the rainy season. Ever-increasing requests for assistance throughout the area made it hard at times to establish priorities in the course of spacing wells properly.

17. Beginning in 1957, the exploration program was accelerated by utilizing a private well-drilling contractor from the United States, and by increasing the number of American advisory personnel and equipment in use.

### Training

18. The contractor collaborated in an on-the-job training program in all phases of drilling, developing, and testing of wells, equipment maintenance, and operation of pumping equipment. The hydrology section also carried on a training program on methods of testing and evaluating wells. Technicians received training in the use of electric loggers, methods of conducting and evaluating pumping tests, measuring water levels, collecting water samples, and use of conductivity meters and other laboratory equipment

used for preliminary water analysis.

19. Three Thai engineers have been sent to the United States for graduate study in the field of hydrogeology.

#### **Present and Future Work**

20. Since May 1961, the Thai Geological Survey has continued exploration drilling, and sunk some 176 wells in a 12-month period. These range from 50 to 1,537 feet in depth (average depth 227 feet). Seventy-four percent of these were completed as production wells. The Thai Government plans to continue groundwater exploration and development in the northeast, and to investigate other areas as trained men and equipment become available. The schedule for 1963 provides for drilling 200 to 250 production wells, mostly in northeastern Thailand. A few exploration wells will be drilled in other areas. The exploration phase of the

program is being kept somewhat flexible. Geophysical work has recently been started as a supplement to drilling in tracing out aquifer boundaries (particularly in small alluvial areas), and possibly in delimiting areas of highly saline waters.

21. A comprehensive report is now in preparation by the Royal Department of Mines. Three reports have been issued to date: (a) "Reconnaissance of the Geology and Ground Water of the Khorat Plateau, Thailand", U.S. Geological Survey, Water Supply Paper 1429, 1958. (b) "Report on Ground Water Exploration and Development of the Khorat Plateau Region", Thai Royal Department of Mines, Ground Water Bulletin No. 1, 1959. (c) Final Report, "Ground Water Exploration of the Khorat Plateau", Daniel, Mann, Johnson and Mendenhall, International, Los Angeles, California, July, 1961.

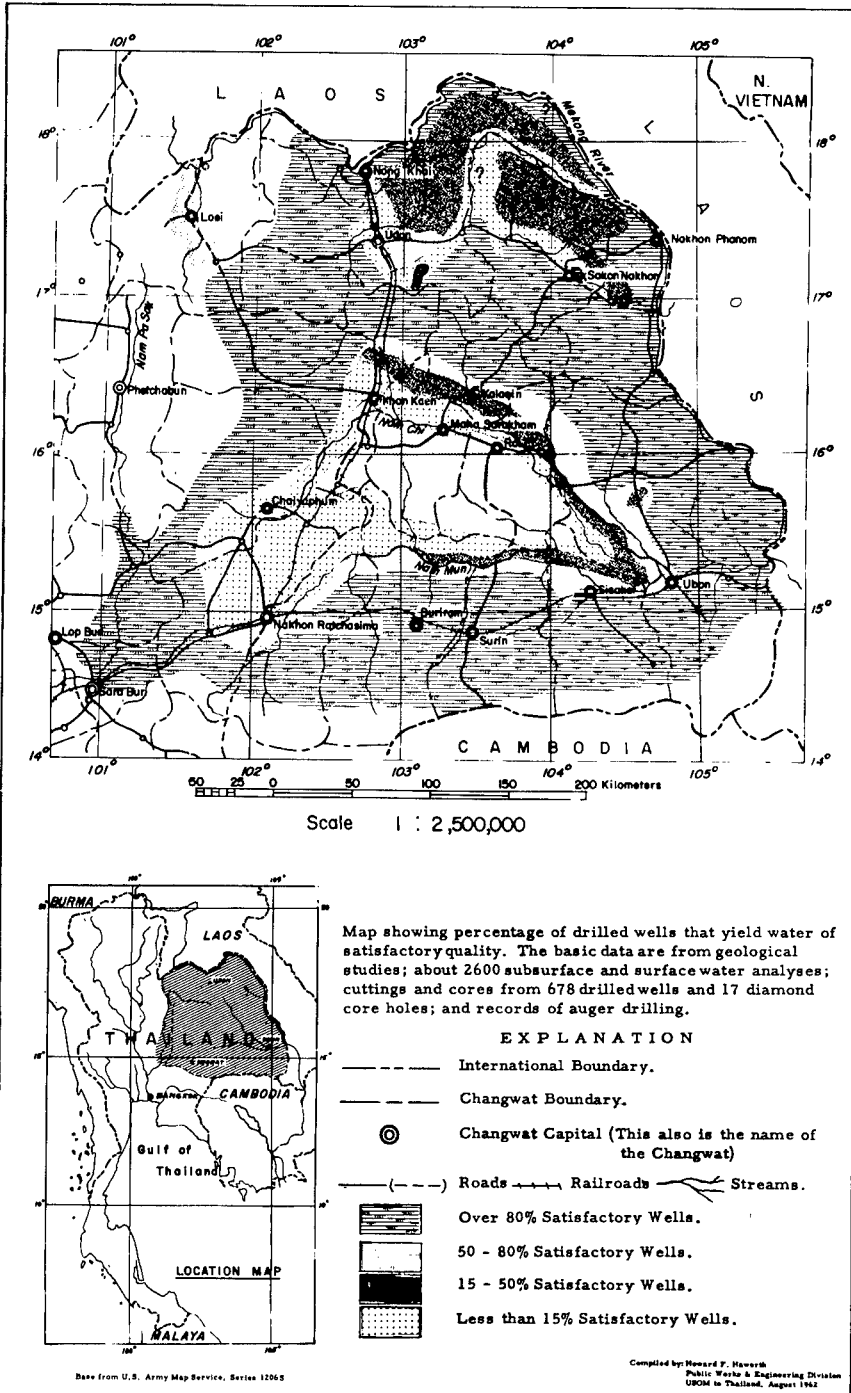

FIGURE I. Ground water availability in Northeastern Thailand.

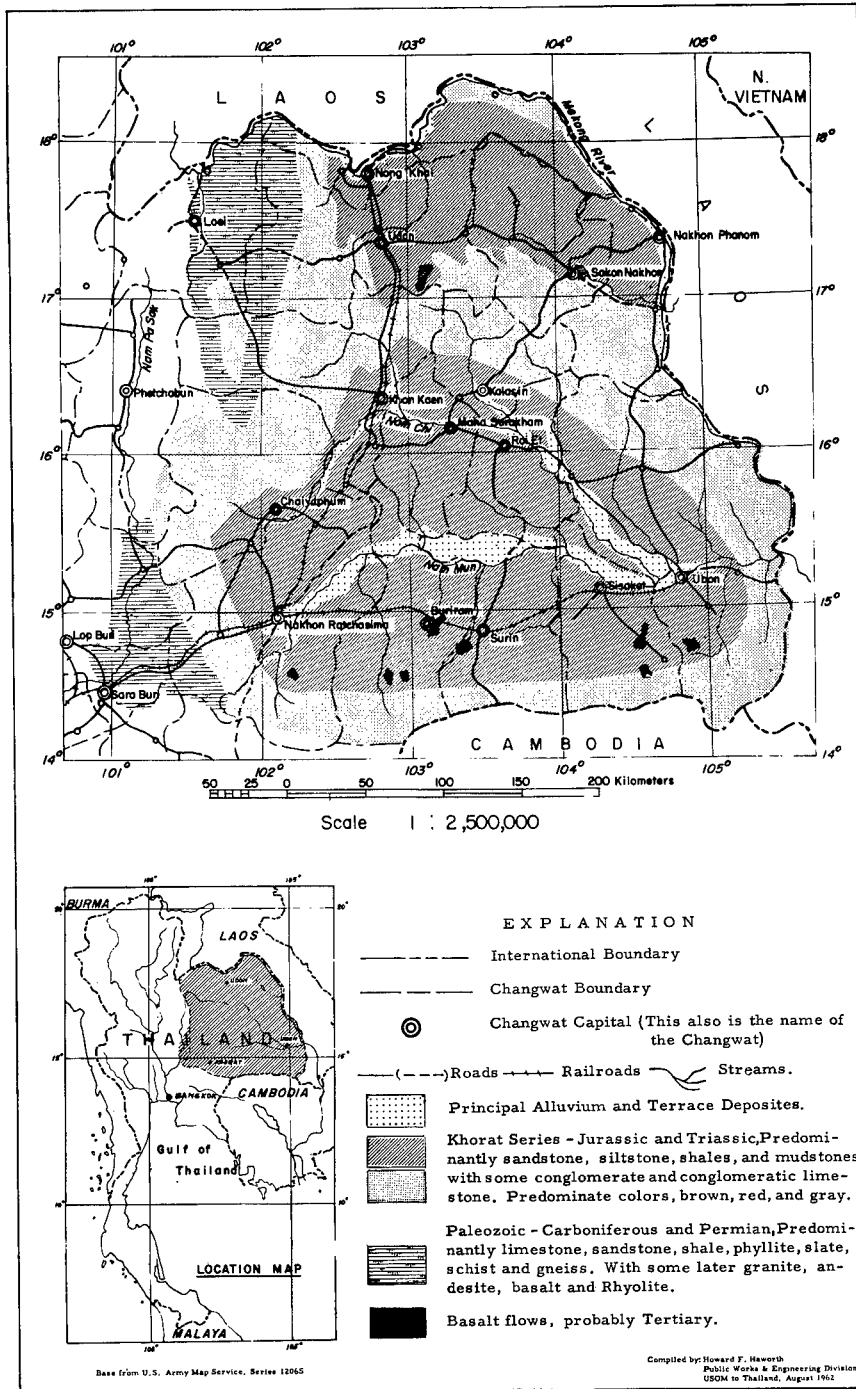

FIGURE II. Reconnaissance geologic map, Northeastern Thailand.

# Hydrology and Scientific Reclamation in the Punjab, West Pakistan

D. W. GREENMAN

*Chief of Party, U.S. Geological Survey Ground Water Group, West Pakistan*

## Introduction

1. Punjab means five waters, and in its geographic sense refers to the vast alluvial plain—40,000 square miles in area—traversed by the Indus River and its five major tributaries in the northern part of the Indus Plain (figure 1). Similarly, doab means two waters and refers to the interfluvial area between two rivers. Thus, the Punjab of West Pakistan comprises four doabs—Bari Doab between the Sutlej and Ravi Rivers, Rechna Doab between the Ravi and Chenab Rivers, Chaj Doab between the Chenab and Jhelum Rivers, and Thal Doab between the Jhelum and Indus Rivers.

2. The Punjab is essentially a flat featureless plain which slopes gently toward the southwest at an average gradient of about one and one-half feet per mile. Natural internal drainage is poorly developed. Intermittent drainage channels, called "nalas", carry monsoon runoff to the major rivers during the summer months, but they are dry throughout most of the remainder of the year.

3. Virtually all of the runoff of the Indus Basin is derived from snowmelt and precipitation in the Himalayas. The average annual discharge of the rivers, where they enter the plain, is over 160

million acre-feet (maf) of which more than half is contributed by the Indus. The rivers are subject to extreme seasonal variations of flow, the mean monthly discharge during the summer being about 15 to 20 times that of the winter months. In a typical year the period of low-flow extends from December to March. The rivers begin to rise during March with the melting of the Himalayan snows and reach their peak discharge in July or August during the height of the monsoon. About 60 percent of the annual discharge of the rivers is concentrated in the 3-month period, June to August.

4. The climate of the Punjab, typical of the low-lying interior of the Indo-Pakistan sub-continent, is characterized by large seasonal fluctuations in temperature and precipitation. It is continental, and ranges from sub-humid in the northeast to arid in the southwest. Maximum temperatures higher than 105° F are common during the summer months of May through August. Winters are relatively cold. Daytime temperatures in the sixties and seventies and night-time temperatures in the high thirties are typical of the months of December to February. The mean annual temperature ranges from about 70° F in the northeastern

parts of Rechna and Chaj Doabs to about 85° F in the southern tips of Bari and Thal Doabs.

5. The Punjab is located on the eastern fringe of the monsoon belt. Precipitation is scanty and sporadic, and not a dependable source of crop moisture. Average annual precipitation ranges from over 30 inches in the upper reaches of Rechna and Thal Doabs near the Himalayan foothills, to about 6 inches in the southern parts of Bari and Thal Doabs. But precipitation rates diminish rather abruptly south of the foothills, and most of the Punjab receives less than 14 inches of rainfall in a typical year. The seasonal distribution of precipitation is the same for the entire area; about 70 percent of the annual precipitation occurs during the monsoon period of June through September.

6. The soils of the Punjab are of alluvial origin and contain high percentages of silt and fine to very fine sand. According to preliminary land classification studies, about 60 percent of the area of Rechna and Chaj Doabs is unsuitable for irrigation, chiefly as a result of salinity. But the soils are inherently fertile and well-drained, and highly responsive to conventional reclamation measures. If the salinity hazard were eliminated 90 percent or more of these lands would be classified as suitable for irrigation farming. Except for the desert area of central Thal Doab, approximately the same conditions obtain elsewhere in the Punjab.

7. The Punjab's economy is largely agricultural, based upon an intensive system of canal irrigation that was introduced over one hundred years ago. Rural population density is high, averaging about 5 hundred persons per square mile and exceeding 8 hundred persons

per square mile in some areas. About 75 percent of the population of the Punjab is supported by agricultural activities.

8. There are two crop seasons—the "Kharif," which extends from April to October and includes the monsoon period; and the "Rabi," which includes the dry winter months. The principal Kharif crops are cotton, sugarcane, rice, and maize. Wheat is the chief crop during the Rabi season.

#### **History and Problems of Irrigation**

9. The climate of the Punjab makes irrigation a prerequisite to intensive agriculture; and the favorable combination of other natural factors such as abundant surface water, flat terrain, and inherently fertile and well-drained soils, makes irrigation feasible. Thus throughout recorded history man has contrived ways to divert water to cultivated fields.

10. The oldest method of irrigation in the Punjab is flood irrigation, locally known as "sailab," which is restricted to the active flood plains. Crops, mainly wheat, are planted after the recession of the summer flood waters. Lands under sailab irrigation retain their productive capacity indefinitely and the method is still employed in riverine areas, most of which are not served by canals.

11. Canal irrigation in the Punjab began at about the end of the 17th Century with the construction of inundation canals which draw water from rivers during periods of high stage for distribution to upland areas bordering the flood plains. The original purpose of the inundation canals was to furnish water for Moghul parks and gardens. However, some diversions for agriculture were permitted and the results were so success-

ful that subsequent canals were constructed primarily for agricultural purposes. By the middle of the 19th Century a rather extensive network of canals was in operation with the maximum development concentrated along the Sutlej and Chenab rivers.

12. The inundation canals represented an advance over sailab methods because they could convey water to more remote areas and draw water through a greater range of river stage, thus maintaining irrigation deliveries for a longer period of the year. But they could only function during periods of relatively high flow, so irrigation was limited to the summer season and to a relatively narrow belt along the rivers.

13. The final step in the evolution of the irrigation system in the Punjab came in about the middle of the 19th Century with the introduction of so-called perennial canals. Permanent diversion works known as barrages or headworks were constructed at strategic sites on the rivers to place the inundation canals under weir control. These facilities allowed larger diversions from the rivers than were possible with the inundation canals, especially during the winter season when low flows could be exploited. Thus, irrigation was extended into the central parts of the doabs, and in many areas the canals operated throughout the year, hence the term "perennial."

14. The first perennial canal system in the Punjab was the Upper Bari Doab Canal which was opened in 1861. This was followed by the Lower Chenab Canal in Rechna Doab in 1896, and the Lower Jhelum Canal in 1901. In 1915, the Upper Chenab, Upper Jhelum, and Lower Bari Canals were completed as parts of the Triple Canal Project which also in-

cluded an extensive system of link canals to transfer water from the Jhelum River and Chenab River to the Ravi River. Between 1915 and 1930 the inundation canals fed by the Sutlej River were converted to perennial canals, and with the completion of headworks on the Indus River at Kalabagh in 1946 and Taunsa in 1958, all of the canals serving the Punjab had been converted to weir control.

15. Average annual diversions through the complex of canal systems are about 26 maf which are used to irrigate about 13.5 million acres annually. This constitutes about 7 percent of the world's irrigated land, and it is probably the largest area of essentially contiguous irrigation development in the world.

16. As canal irrigation always involves diversion and redistribution of surface runoff, some disruption of the hydrologic regimen is inevitable. In the Punjab the hydrologic effects of perennial canal irrigation were especially marked because the same natural factors that made irrigation attractive and feasible were also the sources of serious hydrologic problems in the artificial environment. Thus the permeable soils favored canal leakage which dissipated 40 percent or more of canal diversions within the distribution system. Apart from depleting the supply available for irrigation, the seepage losses formed a new increment of groundwater recharge which, under the flat hydraulic gradients that prevail in the Punjab, can not be disposed of through subsurface drainage. Hence, throughout the Punjab, the inception of canal irrigation was followed by a period of rising ground water levels. This trend persisted until the water table rose sufficiently near land surface to establish a new equilibrium in which evaporation losses were the dominant discharge factors.

17. Those conditions formed a nearly ideal setting for salinity and water-logging, and these hazards were amplified by inefficient management practices. In the Punjab irrigation is operated for revenue benefits rather than for reclamation benefits. With this philosophy and with the pressure of a growing population on the land, the tendency has been to expand the irrigated acreage and adjust irrigation applications accordingly, rather than adjust the irrigated acreage according to the availability of irrigation supplies. As a result, irrigation applications are generally inadequate to satisfy the consumptive uses of the crops, not to mention leaching requirements of the soils. And the combined effects of river regimen and terrain precluded additional development of surface water to make up the deficiency in the irrigation supplies. About 70 percent of the runoff occurs in the summer months, but most of this is wasted to the sea because the flat plains do not offer favorable reservoir sites.

18. In this environment, characterized by deficient irrigation supplies and inadequate subsurface drainage, the economic utility of the irrigated lands has steadily depreciated. Over 8 million of the 13.7 million acres under irrigation in the Punjab are to some degree affected by salinity. Of this about 3.5 million acres are classified as seriously affected, including 1.5 million acres that are out of production. Salinity is encroaching upon new lands at the rate of about 100,000 acres a year, of which about half goes out of production. Furthermore, crop yields from unaffected lands are only a fraction of world averages owing to the inadequate application of irrigation water.

19. The potential hazards of inadequate subsurface drainage in the Punjab were recognized soon after the perennial canals went into operation. Beginning about 1870, observation wells were established in the irrigated areas, and a schedule of semi-annual ground water level measurements was adopted to monitor the effects of irrigation activities on the water table. The networks of observation wells were extended as new areas were brought under irrigation and now comprise several thousand wells.

20. Since about 1915, when salinity and water-logging began to rank as major problems, the observation-well data have been subjected to frequent study by various government commissions, officers on special duty in the irrigation service, and scientists from universities and government bureaus. Most of the studies were too limited in scope to evaluate all pertinent factors, and the findings were generally inconclusive and often misleading. On the basis of these studies various remedial measures were employed including closure of canals during the monsoon season, construction of open-ditch drains in water-logged areas, and planting of phreatophytes along canals. The most ambitious effort was the installation of about 1,600 drainage wells along major canals in Rechna and Chaj Doabs. However, none of these measures provided more than temporary or local relief, and the regional problems of salinity and water-logging continued to increase in severity. Thus, down through the years, canal leakage, water-logging, and salinity came to be regarded as undesirable, but inevitable, concomitants of irrigation, and inefficient practices were accepted as the only compro-

mise between the opposing factors in the system.

### **Effects of Recent Hydrologic Investigations on Reclamation Planning**

21. The first comprehensive study of the problem of subsurface drainage in the Punjab was made by Carlston (1953) under a United Nation's grant. He examined all available hydrologic data for Rechna Doab and concluded that leakage from the canal distribution system was the major factor involved, but he recommended further detailed studies to provide an adequate basis for planning reclamation activities. In 1954, a program of comprehensive water and soils studies was begun in the Punjab under a cooperative agreement between the U.S. Foreign Operations Administration (a predecessor of the U.S. Agency for International Development) and the Government of Pakistan. Under the terms of the agreement the Government of West Pakistan has furnished personnel, and field and office facilities. U.S. AID has provided a team of technical advisors on loan from the U.S. Geological Survey, and vehicles, drilling rigs, field and laboratory equipment, and other commodities required by the project.

22. The objectives of the investigations are to inventory the water and soils resources of the Punjab, and to describe the cause-and-effect relationships between irrigation activities and natural hydrologic factors and the incidence of water-logging and subsurface drainage problems which threatens the agricultural economy of the irrigated areas. The ultimate purpose of the information is to provide a scientific basis for the planning of regional reclamation and development

programs, and the design of individual projects under those programs.

23. Most of the basic data on the geology, and on the occurrence and quality of water in the Punjab, have been published by the West Pakistan Water and Power Development Authority (WAPDA) in a series of more than 20 preliminary reports on the investigation. In addition, a comprehensive interpretative report on the hydrology of the Punjab has been completed (Greenman and others) and is now in the process of publication. Subsequent reports will describe in greater detail certain critical aspects of the hydrology until the requirements of the reclamation and development programs are satisfied.

24. From the standpoint of planning water resources development in the Punjab, the significant findings of this investigation are as follows:

(a) Geologic studies show that virtually the entire Punjab is underlain to depths of 1000 feet or more by unconsolidated aluvial sediments which are saturated to within a few feet of land surface. The alluvium varies in texture from medium sand to silty clay, but the sandy sediments predominate, and large capacity wells yielding 4 cubic feet per second or more can be developed at virtually any site.

(b) Quality of water studies shows that the alluvium beneath about two-thirds of the Punjab is saturated to an average depth of 500 feet or more with water of acceptable quality for irrigation supply. The average concentration of dissolved solids in these supplies is less than 1,000 ppm; the upper limit of concentration of acceptable supplies is placed in the range of 1,800 to 2,000 ppm on the assumption that it is feasible to blend ground water with

canal water at a ratio of 1:2. That limit probably is conservative. Reclamation planners now are thinking in terms of using more highly mineralized water under certain conditions. In any event, assuming an effective porosity of 25 percent for the saturated sediments, the volume of useable ground water in storage is on the order of 2 billion acre-feet.

(c) Water level studies indicate that leakage from the existing canal distribution system is the principal cause of subsurface drainage problems in the Punjab, and it is also the major component of ground water recharge. Approximately one-third of the total canal discharge is diverted to ground water storage through canal seepage.

25. In view of the above it is evident that the alluvial aquifer underlying the Punjab is an unexploited resource of enormous economic value—the more so because it is highly susceptible to flexible operation and scientific management. From that knowledge has evolved a new approach to reclamation which is based on working with, rather than against, the hydrologic factors. It is now recognized both by reclamation officials in Pakistan and international aid agencies abroad that scientific development and management of the ground water resources is the key to permanent irrigated agriculture in the Punjab. From the results of the ground water studies, WAPDA has prepared a long-range program for reclaiming the irrigated lands of the Punjab (WAPDA, 1961). The essential feature of the program is a network of tube-wells, located on an average density of about one per square mile. Where the ground water is of acceptable quality the wells discharge into the canal system, and the yield of each well is

determined by the supplemental irrigation requirements of the land under its command. Thus, the ground water withdrawals serve the dual purpose of satisfying irrigation requirements and providing subsurface drainage. The system offers a permanent solution to the problem of the leaking canal because it both controls the effects of leakage and salvages the losses from the canals. In fact, under this kind of operation, canal leakage is an asset to the system rather than a liability because it constitutes the major component of recharge to the ground water reservoir.

26. In areas where the quality of ground water is unsatisfactory, the wells discharge into drainage ditches, and the yield of each well is determined by the subsurface drainage requirement of its area of influence. In these areas the tube-wells offer only a compromise solution to the problems of canal leakage. They control the effects of leakage but do not salvage the losses, hence canal leakage remains a liability and operates only to put an extra burden on the well-drainage system.

27. The first tube-well project under this program went into operation in 1961. It comprises nearly 2 thousand wells which serve an area of about 2 million acres in Rechna Doab (figure 1). During 1962, construction is scheduled to begin on several other projects in Chaj Doab. Future development is planned at the rate of about 15 hundred wells per year. About 25 thousand wells will be required to serve all of the irrigated areas of the Punjab.

28. Tube-well reclamation methods are hydrologically feasible in the Punjab. That is, with respect to drainage, the position of the water table can be controlled by pumpage; and with respect to

supplemental irrigation supplies, there is sufficient ground water in storage and adequate recharge to sustain large-scale withdrawals for an indefinite period. Furthermore, ground water supplies offer some unique advantages to the irrigation system. Unlike canal supplies they are not subject to seasonal variations, and they can be developed to serve virtually any topographic situation. Thus, ground water can be used to meet seasonal deficiencies in canal supplies and to extend irrigation to areas that cannot be brought under command of canals.

29. Despite the feasibility and inherent advantages of tube-well reclamation methods, it is inevitable that just as superposition of the canal system on the native environment caused undesirable side-effects, the tube-well reclamation projects will again disturb the environment and introduce new problems that will require new solutions. From the standpoint of hydrology there are two distinct, but related, potential hazards which must be considered in the design and management of the tube-well projects.

30. Distribution of withdrawals is an obvious question of immediate concern which should be resolved before the tube-well reclamation program is far advanced. According to current estimates the ground water resources of the Punjab appear to be adequate to meet the regional requirements for supplemental irrigation supplies. But there is not a favorable relationship throughout the Punjab between the availability of ground water and the need for supplemental supplies. The ground water potential for irrigation use diminishes from north to south, or down-doab, and is nil in the southern parts of the doabs where the ground water is too highly mineralized for use. On the other hand, the demand for supplemental

irrigation supplies is more-or-less uniform but tends to increase toward the more arid southern areas. Under these conditions it is evident that the design criteria for a program of maximum exploitation of the ground water resources must be based on regional hydrologic factors, rather than on local demand factors. In short, ground water supplies must be developed where they are available and conveyed to points of use. Such a program will involve the transfer of water into the southern parts of Rechna, Chaj, and Bari Doabs, which will probably require remodeling of the existing canal system or construction of new canals. That, in turn, will amplify the problems of canal leakage and subsurface drainage in the areas where the quality of ground water is unfit for use and the leakage can not be salvaged by tube-wells. In those areas, in the interests of conservation of water and economical drainage operations, it may be feasible to inhibit canal leakage using the emulsion-type sealants that can be applied while the canals are in service. There are alternative methods of conserving water in the areas of deficient supply, such as reducing the intensity of cultivation or modifying the cropping pattern. Regardless of the details of the regional program, it is essential that individual tube-well projects be designed to accommodate the requirements of regional development. Otherwise ground water development will be unbalanced, and in some areas more serious problems may be created by over-development of the aquifer than will be solved by the reclamation activities.

31. Maintenance of a favorable salt balance in the ground water supply is a related problem—related in the sense that pumpage will trigger changes in the hydrologic environment that will in-

fluence the quality of water relationships in the aquifer. Several inherent factors in the tube-well systems will tend to depreciate the quality of ground water with time. Firstly, the leaching of the soil profile that will occur when full irrigation supplies are available will add appreciable amounts of salt to the ground water in storage. The effect will be most pronounced in the early years of reclamation when the residual of salts that have accumulated during the past years of irrigation will be leached from the soil. Secondly, the reduction in volume of the ground water in storage that will occur in response to pumping will cause a proportional increase in the mineral concentration of the ground water. In the cycle of recirculation of water from the aquifer to the irrigated fields and back to the aquifer, most of the salts will remain in solution whereas most of the water will be lost to evapotranspiration. Thirdly, there will be an annual increment of salts derived from canal irrigation supplies which will also be transported down to the water table. Finally, chemical reaction between the percolating recharge water and the unwatered sediments will bring more salts in solution. In addition to the above factors, which essentially involve mobilization of salts, there are the added hazards of lateral and upward migration of saline waters into fresh-water zones in response to pumping.

32. The effects of these factors will be mitigated somewhat by dilution with other components of recharge such as seepage from canals and rivers, and infiltration of precipitation; and by blending with ground water in storage in the aquifer. It is not even possible to estimate the changes that may occur in the quality of ground water because so many

unknown variables are involved. But considering the enormous quantity of ground water in storage in relation to the annual rate of recharge under the reclamation program it is reasonably certain that the rate of change in quality will be slow and will not present serious problems in the near future, or probably within the 40- to 50-year economic lifetime of the present group of projects. If the tube-well reclamation operations are continued indefinitely it may ultimately be necessary to provide for the removal of salts from the area of development, unless technological advances in the meantime offer a better alternative. It may also be feasible to enhance the quality of the ground water by promoting artificial recharge through canals and other structures that are designed to leak.

33. These and other problems and policies of water resources management will be studied under the so-called Mona pilot project which will be operated by WAPDA with the assistance of U.S. AID. The pilot project occupies an area of about 150 square miles northeast of the city of Sarghoda in Chaj Doab (figure 1). It involves the installation of 140 tube-wells having an average capacity of about 3 cubic feet per second, and related supplemental surface drainage and distribution works. Construction is scheduled to be completed in the spring of 1963 in time to begin operations in the 1963 Kharif growing season.

34. This area was selected because it contains most of the essential elements of the hydrology, both natural and man-made, that occur elsewhere in the Punjab. Thus, it will be possible to reproduce or simulate on an experimental scale most of the problems that are likely to arise in connection with the management and operation of the full-scale reclamation

program. With the experience gained from the pilot project coupled with careful monitoring of the full-scale reclamation projects, it should be possible to anticipate major hazards and adopt appropriate counter-measures before serious problems develop.

35. The implications of the tube-well program go beyond the immediate irrigation problems of the Punjab. If the program is successful it may point the way to a final solution for the most vexing problem of water management in West Pakistan—that of storage. The potential for on-channel storage in West Pakistan is inadequate to provide full control of river flow, and even the most favorable reservoir sites have serious shortcomings. For example, the two major dams included in the current development program, Mangla on the Jhelum River and Tarbela on the Indus River, each have a reservoir capacity of only about 5 million acre feet. That is less than 10 percent of the discharge of the Indus Basin, and it can only be utilized once a year owing to the characteristics of the river flows. The reservoirs are remote from areas of water use and they are relatively short-lived because of the high sediment load of the rivers. Present estimates indicate that the useful reservoir life of Mangla Dam will be on the order of 50 to 60 years and of Tarbela about 40 years. There are few other feasible reservoir sites in West Pakistan and they are similarly handicapped in any event, so in the long run it probably will be necessary to develop other storage facilities for surface runoff.

36. Diversion of surplus surface water to ground water storage appears to offer the most favorable prospects for control of the runoff of the Indus Basin. The alluvial aquifer that underlies the Punjab

is ideal for the purpose in nearly all respects. It is favorably situated with respect both to availability of recharge and to areas of use of the water, and there are no extensive geologic barriers to recharge or to circulation within the aquifer. The storage capacity of the ground water reservoir is equal to many times the annual flow of the Indus River system and the reservoir has an indefinite life, because ground water recharge is free of sediment. Thus the use of ground water storage would permit more flexible and complete control of the water resources of the Indus Basin. The ground water reservoir can be replenished according to the availability of surface water for recharge, and it can be tapped according to the demand for water without regard to seasonal or annual variations in runoff.

37. The major problem involved in the management of the aquifer as a reservoir is that of promoting artificial recharge at a sufficient rate to accommodate surplus surface supplies during the periods of high runoff. Although the problem is formidable, a solution probably will be found as a normal consequence of operations under the tube-well reclamation program. If the history of other areas is repeated in the Punjab, demand for ground water supplies will increase through the years and the threat of overdevelopment will stimulate research on methods of conserving water and inducing recharge. In that manner the tube-well reclamation program may ultimately evolve into the broader water management operation simply by the process of diverting more and more of the surface runoff to ground water storage until the entire supply is allocated. If these activities are pursued aggressively it

is not unlikely that the present generation of surface reservoirs will be the last for West Pakistan. By the time their reservoir capacity is depleted, their function may have been preempted by ground water storage.

#### REFERENCES

Carlston, C. W., *History and causes of rising ground water levels in the Rechna Doab*: United Nations, FAO Report No. 90, 1953.

West Pakistan Water Power and Development Authority, 1961, *Program for water-logging and salinity control in the irrigated areas of West Pakistan*: West Pakistan Water and Power Development Authority, Lahore.

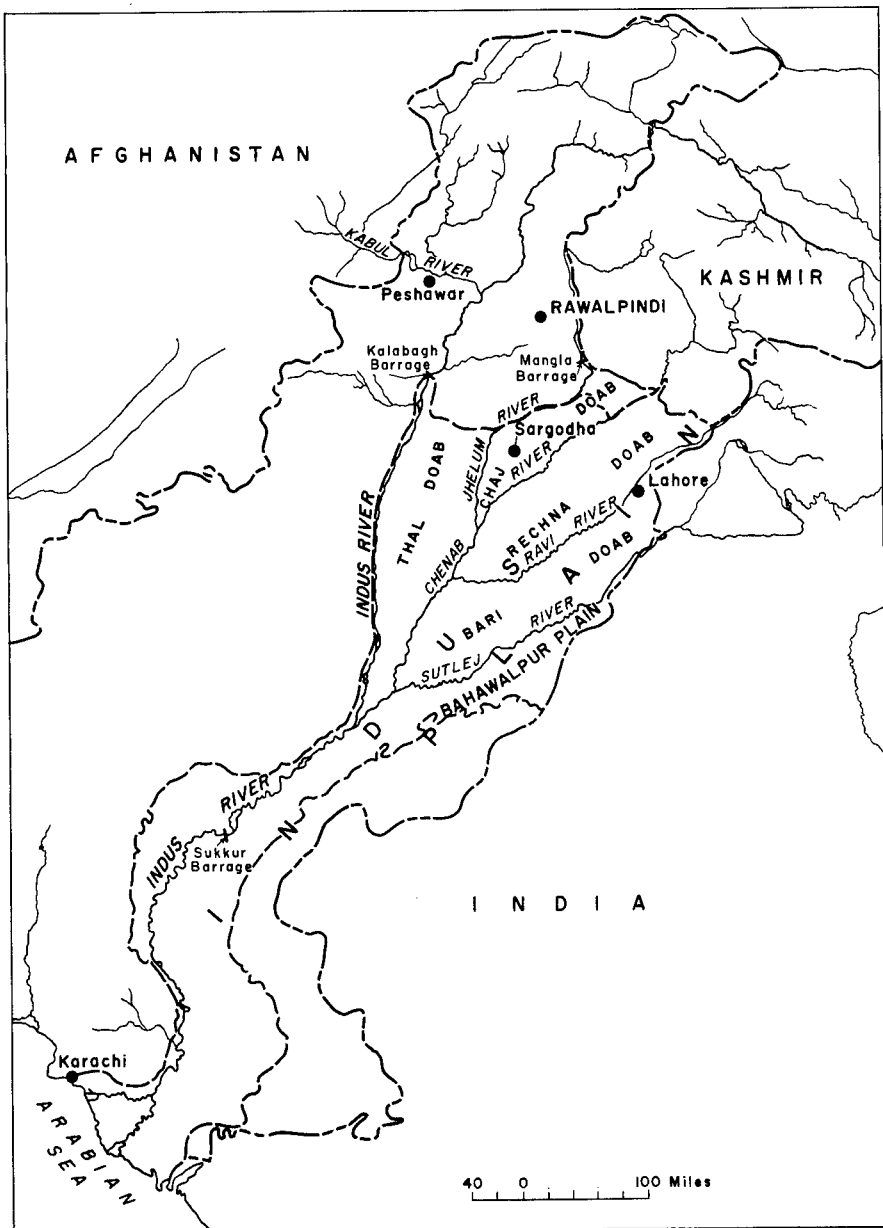

FIGURE I. Maps showing location and principal features of the area.

# Making Wise Use of Flood Plains

GILBERT F. WHITE

*Chairman, Department of Geography, University of Chicago, Chicago, Illinois*

HOWARD L. COOK

*Office of the Chief of Engineers, U.S. Corps of Engineers, Washington, D.C.*

1. Its attempt to reduce flood losses while permitting unrestricted development of its flood plain lands has taught the United States some costly lessons. The primary purpose of this paper is to help less developed countries take advantage of those lessons. To this end, the history of floods and flood control in the United States is briefly outlined, and the various methods used to reduce flood damages are discussed. Special attention is given to the necessity of regulating the use of flood-plain lands if their contribution to national income is to be maximized. Conclusions drawn from U.S. experience are offered in a form intended to make them most useful to the developing nations.

## Historical Background

2. When the first Europeans reached the Atlantic shores of the New World they found themselves between the sea and a vast wilderness. Here they established their first settlements, and from these footholds successive waves of migration moved inland. The earliest interior settlements were located along the larger rivers because these constituted the only

commercial highways down to the sea and the ships which were to bear the products of the frontier to the markets of the Old World.

3. Even after roads and wagons replaced rivers and boats as the main mode of transportation, valley bottoms remained the preferred locations for new towns. During the Nation's earlier years there were compelling reasons for this. The value of the river as a means of transporting freight continued, and even today some cities retain their commercial importance because they are located on inland waterways over which heavy commodities may move at low cost. In addition, the soils of the flood plains were, in most instances, found to be more fertile than those of the uplands. In some cases, the fact that the river provided a cheap and ample water supply was decisive. When the new Nation ventured into manufacturing, river-bank locations became even more desirable because the stream could provide power for the machinery, which in those days had to be connected directly to the water wheels. As villages grew to cities, the river became a means for disposing of wastes. Also, as cities became centers of industry

and commerce it was found cheaper to build factories and commercial buildings upon the relatively level lands of the flood-plain. This trend toward concentrating industry in the river valleys was greatly strengthened when the railroads became the principal means of freight transportation, for the cost of constructing and operating railroads could be held within reasonable bounds only by following easy grades. Though this factor is not as important in the design of modern automobile highways, these often follow the rivers because they connect cities located thereon.

4. It is evident that if the locations of cities were being selected under modern conditions, there would be less reason for locating vulnerable portions of them in the paths of floods. After a city gets a start, however, the possibility of a change in situation becomes negligible, although there may be progressive readjustment in the use of the local site. Private enterprise cannot abandon an investment, once sunk, so long as there appears to be any chance of its yielding a return. This powerful factor is reinforced by the inertia of communities—a trait stemming directly from the psychological characteristics of *Homo sapiens*.

5. For one or more of these reasons, many important cities of the United States now find themselves with flood problems of great magnitude and difficulty. This is something that nations not so far along in their development may largely avoid, for many of the factors which led to the growth of U.S. cities on flood-plains are no longer operative, or are now avoidable. It follows that these nations, if they plan wisely, need never have to cope with flood problems of the magnitude of those with which the

United States, and some other industrialized countries, have had to contend.

### Early Efforts To Control Floods

6. When the North American states first formed a federal union, it was generally considered that the Federal Government would not assume responsibility for "internal improvements"—a common designation, at that time, for projects now referred to as public works. It soon became clear, however, that only the central government could assume responsibility for improving the navigability of rivers in the interest of interstate commerce. For many years the Federal Government did not go beyond this. But as time passed, the problem of flood control became increasingly important, and eventually (in 1917) the Congress authorized Federal construction of flood protection works along the Lower Mississippi and Sacramento Rivers. Subsequently (in 1928), the project for constructing levees along the Lower Mississippi was enlarged and the Federal Government accepted practically full responsibility for the control of that great stream. In 1936, the first general flood-control legislation was enacted. This was the first of a series of acts—commonly referred to as the Flood Control Acts—under which the U.S. Government has assumed a high degree of responsibility for the solution of flood-control problems throughout the Nation.

7. An extremely important consequence of assumption by any central government of responsibility for protecting flood-plain lands from overflow became evident soon after the United States adopted this policy. Since those who found it advantageous to utilize flood-plain lands had been relieved of the neces-

sity of bearing either flood damages, or the cost of preventing them, there was a large increase in flood-plain investment. As a result, flood damages increased very rapidly, and continue to increase despite a very large annual Federal investment in projects to reduce flood damages.

### Flood Losses in the United States

8. In 1957, the Corps of Engineers of the Department of the Army undertook a nationwide inventory of flood damages in the United States,<sup>1</sup> estimated trends of flood plain development, and on the basis of these data made a projection of "potential"<sup>2</sup> flood damage to the year 1980. The results of this study are shown graphically on figure I. The uppermost curve indicates roughly how the potential average annual damage would have increased over the 50-year period, 1930-1980, had no reservoir, levee, channel improvement, or similar projects been undertaken to reduce flood damages on portions of the Nation's flood plains. To eliminate the effect of changing price levels, all values are expressed in terms of the value of the dollar in 1959.

9. The lower curve indicates the approximate effect of engineering projects, constructed mainly by the Corps of Engineers, on the potential damage. This curve shows that the damage potential increased slightly, despite the expenditure by 1957 of over \$3 billion for flood control projects (about 4.5 billion in 1959 dollars). Branch "A" of the lower curve indicates that to hold the damage potential about constant would require an annual expenditure in the future of more than \$300 million for new flood-control works. Branch "B" shows how the potential damage would increase if for some reason the Federal flood-control program

had been stopped in 1957, but flood-plain development had continued at previous rates.

10. The curves of figure I reveal that, in terms of flood losses, the heavy expenditures being made by the U.S. Government are more than canceled out by the effect of more intensive utilization of unprotected flood-plains. Under 1938 conditions, the average annual economic loss to the Nation was about \$700 million. In 1980 it will be about \$760 million, if by that time a total investment of \$11.5 (1959 dollars) billion has been made in flood-control projects. This means that if future flood-control efforts are confined to the construction of engineering works, while the Nation's citizens continue to develop its flood-plains without regard for the effect on flood losses, expenditures of Federal funds will have to exceed \$300 million annually, on the average, to keep flood losses from increasing. In other words, the cost to the Nation of permitting uncontrolled development of flood-plain lands averages more than \$300 million annually.

11. When the Federal flood-control program was first proposed, the economic argument advanced in its support was that such a program would eliminate a serious drain upon the Nation's economy. Regardless of the causes of this drain, its reduction was, from an economic standpoint, obviously desirable if it could be accomplished at a cost less than the loss. But as indicated above, the economic loss to the Nation has not been reduced. This calls into question the basic economic justification for the great investments the Nation has made; for from the economic standpoint, it is one thing to eliminate a loss, and it is quite a different thing to invest a nation's wealth in a program which, by encourag-

ing continuation of the practices which gave rise to that loss, fails to stop the drain upon the economy. If present policies and programs continue, the more than \$11 billion expected to be invested in Federal flood-protection projects by 1980 will have no more economic effect than would the simple transfer of that amount from the public treasury to the profits of those who have continued to develop flood-plain lands.

#### **Recent Developments in the United States**

12. Recognition of the fact that flood losses in the United States cannot be substantially reduced, even by the present large investments in flood-control works, so long as private interests continue to develop flood-plain lands without adequate consideration of the effect on the Nation as a whole, has led an increasingly large number of informed citizens and governmental officials to conclude that a broader approach must be taken. One indication of this is the widespread acceptance of the need for truly comprehensive plans to guide the development, utilization, and conservation of the resources of major river basins.\* Another is the rapid growth, during recent years, of interest in the regulation of flood-plain use.

13. Twenty years ago, a technical paper dealing in a serious manner with the regulation of flood-plain use was not to be found in the literature. Since that time, there has been a gradual increase in the number of papers published each year. This in itself is a measure of the expanding interest in the field. Moreover, it is a necessary prelude to action.

\*See the paper, *River Basin Planning in the United States*, in this volume.

14. The United States is now in the initial stages of a broader action program. Indications of this are the increasing number of States that have enacted, or are considering the enactment of, legislation to enable or encourage flood-plain regulation.<sup>3</sup> Another notable indicator is the fact that in 1960 the U.S. Congress enacted legislation<sup>4</sup> authorizing the Corps of Engineers to provide States, and political subdivisions thereof, with information concerning the flood hazard on flood plains. This service is provided only upon request. The Tennessee Valley Authority had earlier initiated a similar program in the Tennessee River Basin and demonstrated that it met a real need. Still earlier, the U.S. Geological Survey had developed many of the techniques for the preparation of flood-hazard maps. That agency is still making valuable contributions, the most ambitious of which is the preparation of a series of forty flood hazard maps for the Chicago metropolitan area. These are being prepared in the form of 7½-minute quadrangles.

15. Since in the United States the police power resides solely in the States, they must take the lead in bringing about flood-plain regulation. The Council of State Governments, a non-governmental organization of the States, has recently given serious attention to the problem and is now encouraging all States to take the legislative and organizational steps necessary to enable their subdivisions to regulate flood plain use.

#### **Methods for Solving Flood Problems**

16. Flood plains around the world display a wide variety of measures that are available to people who want to make use of the special resources of land, water,

vegetation, and location that are found in these overflow areas, without suffering undue losses. Theoretically, there are a large number of possible alternatives for use of flood plains. A farmer along the Mekong River, for example, can use the land solely for hunting, he can clear it for grazing, or he can cultivate it intensively, using elaborate systems of water control. He can elevate his house so that it is not subject to direct flood damage, he can build up special areas to take care of his livestock in times of high water, and he can store supplies and keep boats on hand for the emergency. In these and many other ways, he can arrange his use of land and his design and organization of structures so that he can minimize flood losses. There are even larger numbers of possibilities in an urban area. But it is only in a very rare situation that a particular farmer or city dweller uses all the possibilities. In some cases he fails to use what would be likely possibilities because he is not aware of them. In other cases, even though he were aware of these choices, he would not be able to select them because of reasons beyond his control. The major possibilities fall into five classes: emergency action, structural change, flood protection and prevention, land-use change, and public relief.

17. The experience in the United States shows that where public policy is directed primarily to dealing with one of these alternatives, it tends to discourage or actually preclude choice among the others. Thus, the heavy emphasis upon engineering works for flood protection seems to have prevented, for a time, wider attention to structural changes. Studies of flood hazard areas also show that unless public policy is altered suitably, it may make it extremely difficult

for a property owner to resort to other promising methods of flood-loss reduction. Indeed, as the society becomes more industrialized, there is a tendency to concentrate on a few solutions rather than the wide range, and it thus may follow that a rapid period of urbanization and industrialization may lead to a great increase in flood-loss potential even though at the same time, as demonstrated in the United States, the public agencies devote large resources to flood control.

18. It will be helpful to review the principal methods for reducing existing flood losses, for controlling further flood damages, and for spreading the impacts of those flood losses that are suffered.

#### **Methods of Reducing Existing Flood Damages**

19. Any use of the flood plain is likely to undergo some damage at times of high water, but the uses vary tremendously according to their susceptibility to damage. For example, some crops such as soybeans are much less susceptible to flood loss at the early part of the growing season than is cotton or corn. The choice of land use affects the amount and time of losses in agricultural areas. The same applies to urban areas, where a park will experience small losses by comparison with retail shops. One direct solution to reduction of certain flood losses, therefore, is a change in land use. In an agricultural area it may involve a shift in crop. In an urban area it may involve a shift from residential to park use, or from commercial retail shops to parking spaces. These may seem obvious, but are extremely difficult to achieve. There may be serious legal and administrative obstacles. Moreover, such adjustments may be inhibited by national policy.

20. The traditional ways of reducing flood losses by public action are to reduce the area subject to overflow by engineering works and land treatment. The chief methods which technology provides are: (a) reducing flood runoff by land treatment, although this alone is effective only to a limited degree and in very rare situations, (b) reducing peak rates by storage of the flood runoff in reservoirs, (c) decreasing peak stages by increasing the channel capacity, and (d) confining the flow of water through the construction of levees and walls. An engineering project may involve all four of these means or some combination of two or more of them. The more common methods of flood control are through channel improvement, reservoir construction, and the building of levees and walls.

21. Formerly, considerable attention was given, in the United States, to the possibilities of reducing flood runoff by land treatment; that is, by reforestation, forest improvement, conversion of cultivated land to grass, improved farming methods, contour cultivation, and similar measures. It was found, however, that land treatment had relatively little effect on major floods—although it may considerably reduce small frequent floods, and hence the total runoff. Since World War II, the agricultural agencies of the United States have turned to engineering works to reduce the larger floods in the small headwater valleys in which they have been given responsibility for flood protection. These agencies usually recommend systems of small reservoirs to store flood flows temporarily and release them through ungated outlets at rates less than the capacity of the downstream channels. In some instances, this is combined with channel enlargement.

22. In the urban areas, the catastrophic event, such as the great Kansas City flood along the Missouri River in 1952, may bring a major part of the national toll of flood losses. Kansas City had been protected by levees against floods of lesser magnitude and additional reservoir protection upstream had not yet been completed. In these cases, it is well to remember that, by encouraging development, the construction of levees or channel improvements which are subject to failure when overtaxed by a flood greater than that for which the project is designed may induce tremendous losses, and that the catastrophic effects may possibly outweigh the benefits from prevention of the floods of lesser magnitude and greater frequency.

23. Reservoirs, if properly designed, are not subject to failure of this sort, but neither do they necessarily protect against the maximum probable flood, and they may not be able to prevent losses from the very rare event. It has been demonstrated in the Tennessee Valley that a system of large multiple-purpose reservoirs may not succeed in preventing all losses at a nearby damage center, although it may reduce the frequency of great floods.

24. In any event, engineering work is the standard and most reliable method of reducing flood losses at the present time. There is a rich body of engineering experience in design of suitable projects.

25. Structural changes (or "flood proofing") offer a more direct means of reducing losses in individual establishments in the flood plain. The principal examples of structural adjustment are: emergency valves on sewer outlets to prevent the flooding of basements at times of overflow; bricking up of walls and openings

in order to prevent flooding of the interior of structures in flood time; installation of movable bulkheads that can be placed in openings in walls at warning of flood; readjustment of electricity, water, and gas lines so as to remove their more vulnerable parts from reach of flood overflows; and readjustment of storage space and equipment within buildings so as to bring them out of the reach of flood waters. These structural changes may be extremely difficult to install once a structure is constructed, but sometimes they may be introduced with a very small expenditure at the time of construction. For example, cutoff valves may automatically prevent a large amount of basement flooding at very low cost. Such adjustments are becoming popular in intensively built-up areas, as in the central business district of Pittsburgh. A common type of structural adjustment, but one which is not applied as widely as warranted, is in the design of roads, bridges, and earthworks so that they will not experience serious injury at times of high water with the greater velocities and higher saturation surfaces that result from floods.

26. Warning systems provide a means of reducing a substantial part of the ordinary flood loss. If the flood peak can be forecast in sufficient time to permit occupants of flood plains to take emergency measures, it is possible that from 10 to 20 or 30 percent of all losses in urban areas and a substantial amount of losses in agricultural areas may be eliminated. For example, warning of the coming of a flood crest enables a farmer to get his livestock out of the reach of floods or to put them in a position where they will have adequate forage during the time they are isolated by the flood waters. In an urban area, the issuance of a flood fore-

cast enables owners of movable property to elevate it above the reach of floods or to take emergency protection measures within their own buildings. Obviously, one of the chief benefits is in reducing the hazard from loss of life. However, a warning system can be effective only if it is based upon an accurate and reliable forecasting system. In the United States, these systems now have been developed in a rather refined fashion, although they are not applied to all flood-vulnerable areas as yet. For streams producing broad-crested floods which require several days to reach the peak, the forecasting problem is relatively simple. It is much more difficult in the case of small drainage areas with sharp flood peaks. In these instances it has been found possible, by devising forecasting systems involving a combination of stream-measurement and precipitation gauges in the drainage area upstream, in conjunction with radar identification from a distance of the location of intense rainfall, to make forecasts two or three hours in advance of the coming of the flood crest. A 2-hour warning often is enough to achieve large reductions in flood losses.

27. Structural changes combined with warning systems make it possible to carry out a broader type of "flood-proofing" program from which still larger benefits may be reaped. Some of the structural changes, such as the emergency bulkheads, can be put into operation only if given a sufficient period of warning. Experience has shown that a combination of adequate flood warnings with structural measures may render a very complex urban area largely free from flood losses. For example, in the "Golden Triangle Area" of Pittsburgh, a highly built-up central business district center, it is now possible for certain new buildings in the

area to endure up to 15 feet of water without suffering heavy losses. Buildings are watertight, utility lines are so arranged that they are not interrupted by the flood waters, internal waste disposal goes on with the aid of special sump-pumps, and all of this can be put into operation within a few hours' notice.

28. It also is possible in some situations to combine flood-protection work with changes in land use, structural adjustments, and warning systems. It may not always be economic to provide protection by reservoirs, channel improvements, or levees for an entire flood plain, and it therefore remains to consider alternative measures for the other areas. It may also be that changes in the use of the flood plain may be adopted as a means of reducing flood losses where structural changes or warning systems might not be effective. Thus, some communities, such as Milwaukee, Wisconsin, have found it desirable to acquire the flood plains of the area systematically in order to devote them to recreational purposes which experience only a very small amount of flood loss.

#### **Methods of Controlling Future Flood Damages**

29. Because, as indicated in a previous section, the toll of flood losses has continued to rise in the United States, there has been increasing attention to the possibility of curbing future flood-plain use so as to avoid unnecessary damage exposure. One of the more popular, but less sound, expressions of this view is that all flood plains should be reserved for park, forest, or other open-space uses which do not involve damage potential. This is a misleading view and one which needs to be combated wherever there is discussion of

possible regulation of flood plains. It is not at all impracticable to think of rather intensive use of flood plains, as indicated above for Pittsburgh, in circumstances that would lead to very slight flood losses. The problem is not one of prohibiting any kind of use of the flood plain, but of finding optimum use, taking into account not only the flood losses that would result, but also the benefits that would flow from such use. Land-use regulation can be developed to foster the wise choice of flood-plain use, insisting upon careful consideration of the effects on both property owners and the community of permitting the more intensive uses.

30. The most direct and most widely practical form of controlling future flood losses is in the setting of encroachment lines. More than ten States, of which Connecticut, Indiana, and New Jersey are especially vigorous, now actively regulate the building of structures in or filling of channels, with a view to preventing any encroachment which would increase flood stages along the stream or cause problems of erosion or silting. The Corps of Engineers is increasingly requiring that communities agree to regulate flood-plain use as a condition of building protection works. This is a basic step in a long-term program of flood-loss reduction.

31. A principal arm of regulation in the United States is to prevent individual property owners from being victimized by developing property where they are certain to suffer heavy losses in the future. This protective device is especially important in growing urban areas where people move into a new situation without being familiar with the history of flood events in the area which would be commonplace knowledge to the farmers or the earlier inhabitants.

32. Regulation takes three major forms:

(a) Zoning ordinances which specify the kind of use that can be made of a particular area.

(b) Subdivision regulations which indicate the conditions in which new urban development can take place.

(c) Building codes which indicate levels and types of construction which are permitted in flood-vulnerable areas. These may be applied independently or in combination, according to the character of urban growth. All are used in some degree in the United States, but not as widely as would be necessary to assure a full control of growing flood losses. The important point with each is that it takes explicit account of the flood hazard, that it aims to prevent un-economic exposure to flood hazard, and that it leaves the choice of use to public groups or to individuals who take into account benefits, as well as loss, from occupying the flood plain.

33. It should be recognized that these methods of controlling future flood damages may go hand in hand with methods for reducing existing flood damages. Thus, a reservoir project for preventing floods in the upper part of a flood plain may be accompanied, as in the case of a portion of Chattanooga, Tennessee, by local regulations which prevent further invasion of the lower part of the flood plain. This may be tremendously important in areas of rapid industrialization, where the provision of partial protection by engineering works may encourage people to further occupy flood-hazard areas, with resultant increased loss to society. Often the further encroachment leads to still further demands upon the public treasury for enlarged flood protection work. Regulation then be-

comes protection of the government budget against unjustified demands for flood protection.

#### Methods of Spreading Impact

34. The most direct and obvious means of dealing with flood losses where they have not been averted is through public relief. In the United States, this is given by the American National Red Cross, a voluntary agency, and by a wide assortment of government departments that assist flood sufferers with rescue, public health, transport, and financial aid. A difficult problem here lies in the policy of extending assistance without assurances that the sufferer will not return to his old place in the flood plain. Unless care is exercised, the policy can encourage still further encroachment on the natural channel of the river.

35. Another means of spreading the impact of floods is by insurance. At present, flood insurance is available only through a few companies that write policies in special circumstances, chiefly where there has been extensive flood proofing. The Federal Government has given serious consideration to subsidizing the organization of a national system of flood insurance and authorizing legislation has been enacted, but no action has yet been taken to implement the legislation.

#### Selection of Methods

36. It is not possible to say that any one solution, or combination of solutions, to flood problems has proved most effective in the United States. This is because flood plains differ so widely in their assets, and because needs vary from place to place. Levee protection may be effec-

tive and abundantly justified in one valley reach, but quite unwarranted in another. Making the proper selection of methods is at best difficult, and is complicated by differences in planning perspective as well as by the crudeness of means of comparing alternative methods.

37. Differences in time horizons lead to radically different choices between individuals and society, and may lead society to adopt certain public policies to encourage individuals to make other choices. It is important to recognize that any sort of choice by either an individual or society must be based upon some estimate of the impacts of the expected work. It has been shown in urban areas that protection may lead to continued invasion of the flood plain, and that unless catastrophic losses occur, there tends to be a progressive crowding down into the lowlands of the flood plain to enjoy the benefits of: cheaper transport, building sites on which it may be cheaper to build or to operate, and accessibility to waste-disposal facilities. In agricultural areas, there has been less movement into flood plains, but the amount of concentration in flood plains tends to be affected by the availability of suitable agricultural land in the adjoining upland areas. Where there is little land available for agricultural use, there tends to be a higher concentration of intensive uses in the flood plain.

38. One interesting impact of flood-protection work in recent years in the United States has been that, as protection has been provided for certain parts of flood plains, there has been a greater tendency for farmers to gamble upon occupation of lands that continued to be highly exposed. This "levee effect" leads farmers who have some land provided a high degree of protection by levees to take greater risks in cultivating the lands be-

tween the levees and the stream channel, knowing that, although they will occasionally experience severe losses, they will be able to take a larger risk because of their more secure base of operations.<sup>5</sup>

39. In a developed flood-plain area, the selection of a suitable method will, of course, involve consideration of reduction in damages by protective measures, changes in land use, structural changes, warning systems, and possible regulations of future use. These may be applied in various combinations in given situations. An essential lesson is that reliance should not be placed solely upon any one of these. It is a very rare situation in which flood protection, or flood warning, or any of the other methods will be completely effective if used alone. It is desirable to think of these measures as providing a kit of tools, two or more of which are used in doing most jobs of flood-loss reduction.

40. For undeveloped flood plains, the problem may be somewhat simpler, but it also involves difficult questions of planning for the future. It obviously is desirable to regulate flood-plain use so as to avoid impairing the channel, victimizing property owners, or creating public expenditures. The absolutely essential step is that of prohibiting flood-plain use which would in any way reduce the capacity of the stream to carry flood flows. An easy test here, as to the need for prohibition of a proposed use, is to ask whether or not such use would cause any damaging change in the level of the flood elevation in the same or another reach of the stream.

41. There has been an unhappy tendency among land-use planners in the United States to think that flood-plain

regulation would provide the whole answer, just as some engineers have tended to think that flood protection provides the whole answer. Neither one has the whole answer; regulation and protection must be worked together.

42. A special problem of making selection among methods is that of choosing in the face of incomplete data and great uncertainty. In few situations is there the kind of data, either as to flood frequency or land use, which would seem completely satisfactory for either defining the flood plain or making choices as to its wise use. The individual planners must move ahead in the face of somewhat inadequate data, using the best judgment they can exercise. Here, it seems desirable to follow the general principle of retaining a high degree of flexibility as long as possible. For example, if it is uncertain exactly how much area would be covered by flood water at maximum flow, it might be desirable to reserve a somewhat larger area for the prohibitive zone than may finally be needed after more detailed hydrologic calculations have been made. It is always easier to reduce the area dedicated to this purpose than to expand it in the face of new agricultural or urban development.

### **The Problems of Flood Plain Regulation**

43. The major problems resulting from a nation's attempts to influence the manner in which its flood-plain lands are utilized are problems of *national policy*. The lawmakers of each nation must make these policies. But in the long run, these policies will be reflections of the views of the people, and will thus depend upon the general public's understanding of what is in the national interest and

what is required to advance that interest. Hence, there is another important group of problems in the field of *public education*. A third group is primarily of interest to economists, engineers, political scientists, and other experts. These will be referred to herein as *technical problems*. Finally, there are difficult *institutional problems* which are of interest to the general public and the politician, as well as the expert.

### **Problems of National Policy**

44. It is self-evident that a nation's objective should be the utilization of its flood plains for such purposes, and their development at such rates, that they make a maximum contribution to the welfare of its people. The economic dimension of this contribution is the difference between (a) the cost, including flood losses, of meeting the nation's needs for goods and services with the flood plain lands in use, and (b) the cost of meeting these needs without using flood-plain lands. In other words, the nation's economic gain is the savings in cost made possible by the utilization of its flood plains. If a country can produce what it needs on lands not subject to flooding, at a cost no greater than that required to obtain the same production on flood-plain lands, it will gain nothing by utilizing its flood plains; that is, there will be no saving from the standpoint of the nation as a whole. In more general terms, a nation which has an alternative to the use of flood-plain lands will benefit from the use of those lands only if the cost of meeting its needs by the alternative means exceeds this cost by an amount greater than the flood damages suffered. If an effort is made to prevent the flood damage, the use of the flood-plain lands is justified

only if the cost of providing protection is less than the extra cost (if any) of utilizing the uplands to meet the nation's needs.

45. It will be obvious from the foregoing that a nation suffers an economic loss when it uses its flood plains to achieve an increase in production which could have been obtained at a lesser cost by the use of its uplands. But the owners of flood-plain lands can gain even though the nation is losing. Moreover, communities located on flood plains can become better off economically while the nation is becoming worse off. In other words, there is, in general, a basic conflict between the national interest and both local community and private interests. It is because of this that the problem of flood-plain regulation is so intractable from the standpoint of national policy. For, within the limitations of whatever system of political principles a nation has adopted, it must find ways of bringing about such use of its flood plains as may best serve the national interest, and under any system this is going to mean that it must thwart the aspirations of the few for the benefit of the many.

46. The difficulties of achieving that use of flood plains which best serves all the people are multiplied by the adoption of a national policy under which the central government assumes the full cost (or a large proportion of the cost) of projects for preventing flood damages. The effect of such a policy is to encourage more intensive use of flood-plain lands than the owners thereof would find profitable if the cost of the protection had to be included as deductions from income in their own accounts. In fact, under such a policy, the cost is transferred from the owners of flood-plain lands to the taxpayers of the whole nation, and may become a

profit to those who use their lands uneconomically. Similarly, if a community is provided protection against floods at the expense of the nation as a whole, it can, by pushing flood-plain development to the point at which the aggregate profits of local interests are maximized, reduce to zero the benefit which the nation as a whole receives from its investment in the flood protection project.

47. The national policies evolved by any country will of course depend, to a considerable extent, upon its political system. Hence, no attempt will be made here to go beyond the foregoing analysis of the fundamental issue.

#### **Problems of Public Education**

48. In the United States, the burden of informing the public about the need for wise use of the Nation's flood plains has been shouldered, until recently, by individuals and non-governmental institutions, particularly the universities. Their efforts attracted the attention of various commissions and other bodies established to study the Nation's water policies and problems. Notable among these were the President's Water Resources Policy Commission, followed by the so-called "Second Hoover Commission," and, most recently, the Senate Select Committee on National Water Resources. These bodies recognized the importance of the subject and urged better utilization of flood plains. As a result of all these influences, there has developed during the past several years, the increasing interest on the part of Federal agencies which has already been described.

49. Attempts to educate the general public have shown that there are a few simple and basic ideas, or concepts, that

must gain common currency before the average citizen can be expected to lend intelligent support to governmental efforts to bring about wiser use of flood plains. Among these are:

(a) The concept of flood probability, or frequency.

(b) A general idea of the possible magnitude and consequences of great floods—interpreted, if possible, in terms of each individual's environment.

(c) The history of floods in the community in which the individual lives.

(d) A general familiarity with alternative means of reducing flood damages, including regulation of use and flood proofing.

50. The concept of flood frequency is still somewhat foreign to the "man on the street." Yet it is not difficult for him to grasp the basic idea when it is properly presented. Flood frequency is simply a measure of the probability that a flood greater than the selected size will occur in any one year. Probability is usually expressed in terms of the proportion of all of the flood events, occurring over a long period, that will exceed a given magnitude. This probability can be converted to the number of floods that will exceed the given magnitude during a selected period (often 100 years). If it is determined that a single flood equal to or greater than the given size will occur in an average 100-year period, such a flood is commonly called a "100-year flood." In this way, "probability" is easily converted to the "average interval" between floods exceeding any given size. It is this average interval that is most frequently used by engineers. Moreover, this way of expressing probability seems to be most easily understood by the general public. But it is of the utmost importance that the public also understand

that the intervals between floods of a given magnitude may vary greatly. For example, it must be made clear that it is perfectly possible for "100-year" floods to occur in successive years, or that a record kept for a century may not contain a true 100-year flood. The expression, "a 100-year flood," means that if a record many centuries long were kept, and the intervals between all floods exceeding the given size were determined and averaged, the average would be 100 years.

51. The residents of valley cities usually have little idea of what stages a great flood might reach, and what areas it would inundate. When this information is made available, it powerfully influences the general public's attitude toward floods and the proper utilization of flood-plain lands. Hence, one of the most effective actions that a nation can take to educate the general public is to make it easy for its cities and towns to find out what areas would be inundated should a great flood occur. As previously noted, the United States has recently initiated a Federal program to provide such information.

52. The attitude of citizens toward floods and flood risks may also be greatly influenced by a knowledge of the flood history of the immediate locality, especially if a great flood has visited that locality in the past. Hence, it is highly desirable that flood history be preserved, and that the community be periodically reminded of it by local newspapers, for example. Another very effective measure is the marking, in prominent places, of the peak stages of large floods previously experienced.

53. Finally, a program of public education should be designed to familiarize the general public with the various methods that can be used to reduce flood hazards.

Most citizens understand how levees confine the stream and keep floods off the outer portions of the flood plain, how the enlargement of a channel can decrease flood stages, and how the holding back of flood waters in a reservoir can reduce downstream flows and stages. In other words, they do not find it difficult to understand engineering projects. But much remains to be done in the way of public education before the ordinary citizen is equally familiar with such an alternative as regulating the use of flood plains so that high-hazard areas are in parks rather than expensive buildings; or with such an alternative as the "flood proofing" of buildings so that damage is minimized when floods do occur. The newspapers and the more popular periodicals can make a valuable contribution by acquainting the public with such alternatives.

#### Technical Problems

54. The chief problems which present themselves to the experts are, in summary:

(a) The collection of more complete basic data on flood flows for basins of different sizes and physical characteristics.

(b) To obtain more and better information on the effects of floods—particularly on the damages they cause under a wide range of circumstances.

(c) To develop the economics of the regulation of flood plain use, and to derive therefrom practical procedures for arriving at decisions as to the best use of specific flood plain areas.

(d) The development of more rational and dependable methods of estimating the probability, or frequency, of floods of various magnitude.

55. Records of stream flow are short in most parts of the world. Moreover, the available records rarely cover the entire range of basin sizes, and never cover all of the variables—such as slope, soil characteristics, and vegetal cover—which influence flood runoff. Such data are, of course, needed for many purposes, and every nation should take immediate steps to improve its program for collecting basic stream-flow data. Also, greater attention should be given to more precise determinations of the discharge of great floods, as at the present time the peak flows of the largest floods are either estimated or very crudely measured.

56. Even in the United States, where billions of dollars have been spent on dams, levees, and other works to prevent flood damages, very little has been accomplished in the way of scientific studies of flood effects and damages. As a result, estimates of future average annual damage, used in calculating the benefits of proposed projects, vary through an amazing range for similar flood-plain uses in regions of similar hydrologic characteristics. In some instances, estimated damages for agricultural areas have amounted to several times the net income that could be obtained from flood-free lands of the same inherent productivity. There are also large discrepancies in estimates that have been made, by different agencies, of the damages caused by the same flood. There seems to be a strong tendency to claim that temporary interruptions of urban activities result in large economic losses, whereas the facts indicate that actual production over a period of time is usually but little affected. For these and other reasons, there is a great need for scientific studies of flood damages.

57. The economics of flood-plain regulation has received little attention from the economists of the United States—or from the economists of other nations, if the literature is a reliable indicator. Here is a broad and promising field for investigation by both the universities and the action agencies. Of particular importance is the development of practical criteria for determining the use to which specific flood plain lands should be put at various stages of the economic development of a nation.

58. Flood records cover relatively short periods, and thus provide such small “samples” of data that often little reliance may be placed upon the estimates of probability arrived at by present statistical methods. In addition, large errors result from the common practice of including, in a sample, floods not belonging to the same statistical “population.” However, more powerful statistical methods for dealing with small samples are constantly being developed, and more is being learned about the relationship between storm rainfall and flood magnitude for a wide range of drainage area characteristics. These developments give promise of future improvements in the reliability of flood frequency estimates.

#### Institutional Problems

59. The institutional problems vary greatly from nation to nation. Hence, U.S. experience may be of little value to other nations and will be mentioned only briefly to indicate the nature of such problems. Illustrative of U.S. problems are those stemming from the fact that the police power can be exercised only by the States. This means that State and Federal objectives and policies must be effectively coordinated. Similar problems

exist between State governments and the political subdivisions of the States, such as counties and cities. It is also essential that the programs of various Federal agencies be coordinated. For example, an agency responsible for administering Federal assistance intended to encourage redevelopment of urban areas must work closely with agencies responsible for flood-protection programs. Such problems deserve careful study by political economists in each nation.

#### Conclusions

60. The conclusions to be drawn from this account of U.S. experience that would seem to be of greatest value to the developing nations are:

(a) *Optimum use of flood plains should be a nation's goal.* The mere avoidance of flood damages by non-use of flood plain lands should not be the objective of national policies and programs. Rather, a nation's aim should be the utilization of such lands up to the point at which any increase in flood plain production could be achieved on other lands at equal or lesser cost.

(b) *Engineering works alone are not enough.* A program to reduce flood damages by the construction of engineering works does not necessarily reduce a nation's flood losses. The beneficial effects of such works can be more than nullified by the continuation of uneconomic flood-plain development.

(c) *Regulation of the use of flood plains is a necessary adjunct to flood protection.* Regulation can make it possible to provide the most economic degree of flood protection by engineering works, without creating a situation that might lead to catastrophe in

the event the capacity of the works should be exceeded by a flood of such small probability of occurrence that provisions for its control cannot be justified on economic grounds. The regulation of flood-plain use as a condition of governmental assistance also provides a means by which a nation can insure that its investments in flood-protection works will not lead to the creation of new flood problems that cancel out the benefits which the nation

has a right to expect from those benefits.

(d) *No single method provides the best answer to the flood problem.* In designing a plan for the reduction of flood damages within a given reach of valley, all methods should be given consideration, with a view to finding that combination of protective works, flood-plain regulation, flood proofing, and other measures which will insure optimum development of the flood plain from the standpoint of the nation.

#### FOOTNOTES

<sup>1</sup> *Floods and Flood Control*, Committee Print No. 15, Select Committee on National Water Resources, U.S. Senate, July 1960.

<sup>2</sup> The term "potential damage" is used to represent the average annual damage that would occur over a long period of time if the use of a flood plain were to be held constant. Stated otherwise, it is the damage that would occur during any one year if the floods experienced during that year were such that flood damage just equaled the long-term average. Of course, actual damages during any particular year may deviate greatly from this potential, or average, damage.

<sup>3</sup> The recent history of efforts to regulate flood plain use are reviewed in *Regulating flood-plain development*, by F. C. Murphy, Research Paper No. 56, Department of Geography, University of Chicago (1958).

<sup>4</sup> Section 206 of the Flood Control Act of 1960, Public Law 86-645 (74 Stat. 500).

<sup>5</sup> Burton, Ian, *Types of agricultural occupance of flood plains in the United States*, Department of Geography Research Paper, University of Chicago (1962).

#### REFERENCES

White, G. F., *Human Adjustment to Floods*, University of Chicago Press, Chicago (1945).

Leopold, L., T. Maddock, *The Flood Control Controversy*, The Ronald Press Co., New York (1954).

Hoyt, W. G., W. B. Langbein, *Floods*, Princeton University Press, Princeton, N.J. (1955).

White, G. F., et al., *Changes in Urban Occupance of Flood Plains*, University of Chicago Press, Chicago (1958).

Murphy, F. C., *Regulating Flood-Plain Development*, University of Chicago Press, Chicago (1958).

*Floods and Flood Control*, Report to Select Committee on National Water Resources, U.S. Senate, by Corps of Engineers, printed as Committee Print No. 15, 86th Cong., 2d Sess., U.S. Govt. Printing Office, Washington, D.C. (1960).

Sheaffer, J. R., *Flood Proofing*, University of Chicago Press, Chicago (1960).

White, G. F., et al., *Papers on Flood Problems*, University of Chicago Press, Chicago (1961).

Burton, I., *Types of Agricultural Occupance of Flood Plains in the United States*, University of Chicago Press, Chicago (1962).

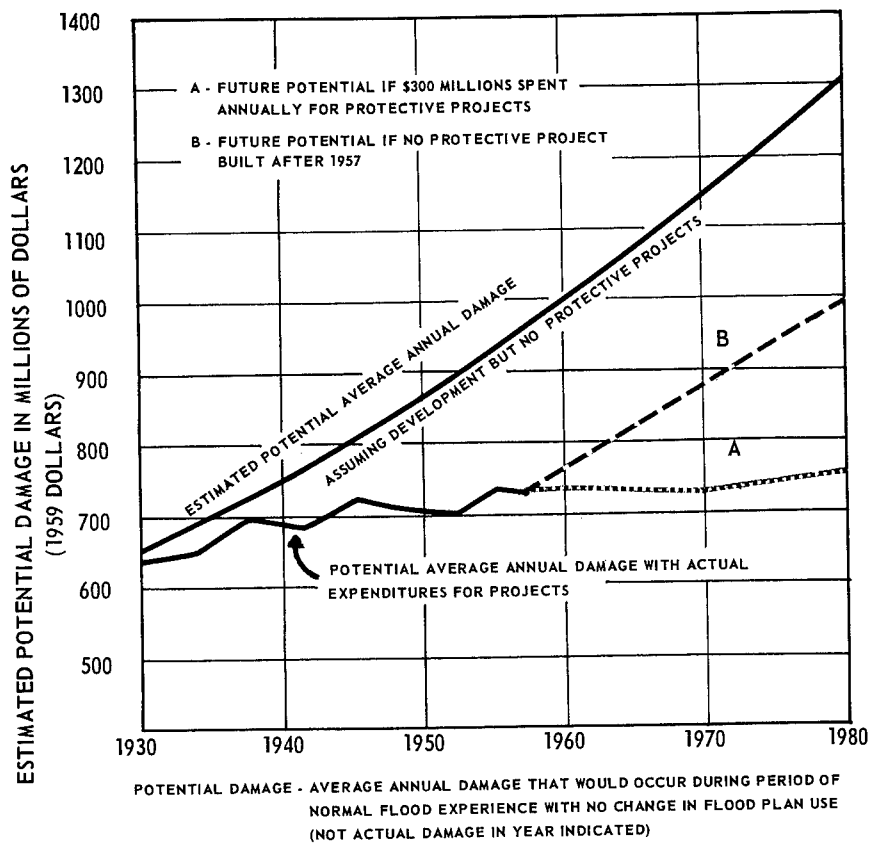

FIGURE I. Growth of potential average flood damage in the United States.

# Desalination; Evaporation Reduction; Artificial Precipitation; Large-Scale Weather and Climate Modification\*

THOMAS K. SHERWOOD

*Professor, Department of Chemical Engineering, Massachusetts Institute of Technology, Cambridge, Massachusetts*

HARRY WEXLER<sup>1</sup>

*Director of Meteorological Research, U.S. Weather Bureau, Washington, D.C.*

1. The earth's total water supply is enormous compared with the needs of mankind; only the extreme variation of its availability with time and place causes water shortages. Rain and snow falling on land areas amount to 33 thousand cu.m. annually for each inhabitant of the globe. This is more than 10 times the generous use of water by North Americans for all purposes, including irrigation.

2. Average figures on water supply are of little comfort to the peoples of arid lands, or to a farmer in Kansas in a year of serious drought. Rainfall averages less than 30 cm. annually (45 percent of the average for all land areas) on more than half the land surface of the earth (1). This is less than the average rainfall in such places as Mogadiscio, Somalia (2), where fresh water is in short supply.

3. Great engineering works designed to impound and distribute water, con-

servation measures, and multiple re-use of water can do much to offset shortages, but in many arid regions these measures will prove inadequate. Science and technology must provide ways to increase water availability.

## Desalination

4. One obvious way to increase water availability is to recover fresh water from the enormous and widely distributed supplies of sea water and of brackish water. Large underground stores of brackish water are located in many arid regions remote from the sea.

5. Research is being carried out in many countries for the purpose of developing practical desalination processes. Much of the work being done in the United States is coordinated and supported by the Office of Saline Water of the Department of the Interior.

6. Of the many desalination processes studied, only distillation and freezing for

\*U.N. Conference paper.

sea water, and electro dialysis for brackish water are now commercial<sup>2</sup>—commercial in the sense that they are promoted by industrial concerns. These and one other will be described briefly: reference (3) provides a bibliography on the subject, and references (4), (5), (6) and (7) describe recent research and development studies of a number of processes.

7. *Multiple Distillation.* The oldest and most used process is distillation. Total installed capacity of sea-water distillation plants is upwards of 80 thousand cu.m. per day. The installations must be large and expensive if the needed energy is to be used economically.

8. Approximately 6 hundred cal. are required to produce one gram of fresh water by simple distillation of sea water, but the great technical invention of multiple-effect distillation makes it possible to reduce this to sixty cal., or even less. Variations of the basic process include multiple-flash distillation (requiring heat transfer surface to condense vapor, but not for boiling) and vapor recompression (requiring electricity in place of heat energy). Studies indicate that for large plants it may be economical to supply the heat required by means of specially designed nuclear reactors.

9. *Solar Distillation.* Solar stills have received considerable study and development, as they serve to provide small quantities of water at moderate cost. Solar distillation is not a different desalination process, but a way of using solar radiation to eliminate the cost of fuel.

10. Though the energy is free, the first cost of glass-covered stills is high in relation to capacity for producing water. Current studies of inflated plastic stills may lead to less expensive designs. In the many regions of the world where the incident solar radiation averages 540

cal. per sq. cm. per day, these stills can produce 12 hundred–16 hundred litres of fresh water annually from each square metre of ground area. They are being used in increasing numbers in arid regions, and have been produced commercially in Algiers and in Australia.

11. The cost of solar stills in relation to capacity is high because the solar radiation intensity is so low. To produce water at a rate equal to the withdrawal and use in North America would require single-effect stills covering an area one-quarter as large as the total area of the cultivated land (4 percent of the total area of the United States).

12. It seems unlikely that solar stills can compete with large multiple-distillation units in the production of water at low cost. Solar stills can be expected, however, to find wide use in converting sea water or inland brackish water to supply the fresh-water needs of small living groups in many arid regions of the developing countries.

13. *Freezing Processes.* If saline water is partially frozen and the ice crystals washed free of residual brine, the ice may be melted to produce fresh water. In one variation of the process an immiscible hydrocarbon liquid is dispersed in the saline solution; vaporization of this material provides the refrigeration to cause the water to freeze. In another process a solid hydrate is formed by contact of water and propane or other hydrate-forming substance. These solid hydrates form at temperatures greater than that at which water ice separates, and the cost of refrigeration is less.

14. Performance data on commercial desalination plants employing freezing processes are not yet available, but engineering studies suggest that freezing may be competitive with multiple-distillation

for large desalination plants. One of the desalination plants to be constructed by the Office of Saline Water, U.S. Department of the Interior, will employ a freezing process. Evidently, the major process problem is the design of an efficient device to wash away residual brine from the partially-frozen mass of very fine ice or hydrate crystals.

15. *Electrodialysis.* This process employs membranes in the form of thin sheets of highly-hydrated organic polymers. The ion fragments of salts in solution are caused to pass through these membranes, but passage of water does not occur.

16. In contrast with distillation or freezing processes, electrodialysis consumes (electrical) energy roughly in proportion to the salt removed, rather than to the fresh water produced. For this reason, electrodialysis is more economical for the desalination of brackish than of sea water.

17. Electrodialysis is now a commercial process, and a number of plants ranging in capacity from a few hundred to 11 thousand cu.m. per day have been installed in various parts of the world. Two towns in the United States employ electrodialysis of brackish water to provide municipal fresh water. Plants of this type would appear to have wide application in many arid regions where quantities of brackish water are available.

18. *Ultrafiltration.* This process, also known as "reverse osmosis," is not now commercial, but is the subject of considerable research in the United States. It employs thin membranes which permit the passage of water, but not of salt, when a pressure of more than about 23 atmospheres is applied (as by a piston) to sea water on one side of the membrane.

19. Too little is known about the mechanism of the membrane process to

permit the selection and manufacture of useful osmotic membranes. Though promising results have been obtained, practical membranes will probably not be developed by trial and error; the basic physics of the process needs to be understood.

20. *Desalination Costs.* Actual data on costs of large-scale desalination operations are quite fragmentary. Sea water plants built 10 or more years ago produced fresh water at costs of \$0.79-\$1.27 per cu.m. Recent commercial plants report costs of \$0.33-\$0.53 per cu.m. These are total costs, including fixed charges, as would be calculated for an industrial enterprise. One electrodialysis plant of medium size is said to desalinate a 2200 ppm. brackish water at a total cost of \$0.12 per cu.m.

21. Though the trend of costs has been downward, the curve would seem to be approaching an asymptote somewhere in the range of \$0.08-\$0.13 per cu.m. for the large-scale desalination of sea water with present energy costs. Though clearly a matter of opinion, it does not now appear that further engineering refinements of present commercial schemes can lead to sea water desalination costs in the range of present U.S. prices charged for irrigation water—generally less than \$0.02 per cu.m. A new combination of scientific principles and technical inventions is needed, or alternatively a marked reduction in the cost of energy.

22. *Prospects for Large Cost Reductions.* From the foregoing, it is clear that desalination costs are now high, and that present commercial processes will find application only in rather special situations. It is of interest to speculate as to the possibilities that much less expensive processes can be developed.

23. Thermodynamics provides a basis for such a speculation. The theoretical

(minimum possible) work-energy required to separate one cubic metre of fresh water from sea water at 25° C., leaving a brine containing the same amount of water is 1.09 kwh. This has a value of only about \$0.01. It is worth asking why present desalination costs for sea water are 30 to 50 times this figure.

24. Part of the answer is that energy represents but a fraction of the total costs, but reduction in the energy required would lead to reduction in other costs. The actual energy is greater than the theoretical because all developed processes involve large thermodynamic losses. Reduction of these losses will reduce costs.

25. In distillation, the transport of water across the liquid-vapor interface involves little thermodynamic loss. Serious losses, however, result from the use of large temperature differences between heating steam and boiling water. Ultrafiltration, by contrast, involves large losses in the osmotic membrane; the necessary work-energy can be supplied with good efficiency by a pump. What seems to be required is a process having the high "membrane" efficiency of distillation, but with the efficient energy supply possible in ultrafiltration.

26. There is no fundamental reason why the theoretical energy should not be approached in a practical process. What is needed is basic research to provide a better understanding of the fundamental science underlying the various methods by which salt and water can be separated. This understanding will provide the basis for invention and process development.

27. *Research Needed in Desalination.* Desalination research and development in the United States has been devoted

largely to engineering modifications and refinements of older processes. The Office of Saline Water is now embarking, however, on an expanded program of basic research.

28. A conference organized by the U.S. National Academy of Sciences was held in the summer of 1961 to consider those research areas of promise. The reports of that meeting are now available (7)(8). The conference concluded that a broader base of fundamental science is necessary in order that present processes may be improved and better ones conceived.

29. The National Academy conference strongly emphasized the need for more fundamental research on water, electrolytes, transport of both water and ions in the liquid phase across phase boundaries, and in membrane materials. Too little is known about salt solutions. Thermodynamic properties of sea water at elevated temperatures are needed. The mechanism of scale formation and the growth of deposits on heating surfaces is not now understood. What is the effect of magnetic and electrical fields, and of sound vibrations, on transport and on scale deposition and growth? What are the barriers to transport of either water or salts across phase boundaries? A quantitative evaluation of thermodynamic losses in existing processes should focus research attention on the most important problems.

30. Basic research on nucleation and growth of crystals is needed to support the development of new and better freezing processes, both water ice and hydrates. Large crystals are needed if they are to be easily washed free of brine—what determines their growth rates, and how can growth be effected with the least chemical potential?

Hydrates which form at low pressures and at temperatures well above 0° C. have only begun to be studied.

31. Both organic and inorganic membranes need study as possible materials for the ultrafiltration process. Are hydrated ions literally filtered, or does water transport require the dissolving of water in the membrane substance? What should be the ratio of amorphous to crystalline substance in the polymeric materials? Should ion-repelling charged groups be incorporated in osmotic membranes? Though ultrafiltration is a very old idea, research on the fundamental physics of osmosis has been neglected.

32. Biology has much to offer which is relevant to desalination, and to the broad water problem. What is the structure of the natural membranes employed by plants and animals to control salt absorption? Perhaps synthetic membranes containing polypeptide chains might simulate nature and be better for osmosis. Nature employs ion pumps, which, if understood, might suggest new approaches to the manufacture of membranes for electro dialysis. Natural photosynthetic desalination organisms need study to see what lessons they offer. Can algae or sea plants be used in a cyclic-staged process, employing the properties of such substances of absorbing water preferentially?

33. This brief review suggests the nature of the needed program of basic research, as contemplated by the National Academy Conference (8). Much money and effort have been directed, with considerable success, to the development of existing desalination processes. But the law of diminishing returns is beginning to apply and desalination costs are too high for most water uses. The hope for

inexpensive water in the future rests on the understanding of basic phenomena, which may be expected to come from a wide-ranging and imaginative program of fundamental scientific research.

### Evaporation Reduction

34. Evaporation from water surfaces is a major cause of water loss. Meyers (9) estimates that the gross annual freshwater evaporation from exposed water surfaces in the 17 U.S. western states is approximately  $28.9 \cdot 10^9$  cu.m. The average annual evaporation from Lake Mead is about  $0.984 \cdot 10^9$  cu.m, which is a volume greater than the storage capacity of most reservoirs in the United States. Obviously, any techniques for reducing evaporation will result in increased water supply.

35. Evaporation losses can be minimized by exposing as little water surface as possible. Therefore, if sites permit, it is advantageous to construct deep reservoirs. When several sites are available, consideration should be given to the location with the lowest rate of evaporation in making the final selection. However, the most promising method of reservoir evaporation reduction is through use of protective films. This procedure will be described in more detail later.

36. Another method of reducing water losses is the use of underground storage instead of surface reservoir storage. Some success has been achieved in the artificial recharge of ground water reservoirs and research into improved techniques is continuing. However, the extent of artificial recharge seems to be limited in some areas by the slow rate

that water will percolate through the ground.

37. Evapotranspiration is not considered a loss when the moisture is being utilized in the growth of beneficial crops and plants. However, the water used by non-beneficial plants, such as phreatophytes, should be classified as a consumptive waste. Phreatophyte eradication is one method of reducing the evapotranspiration losses, but to be effective, requires repeated and expensive treatment. Other solutions are the diversion of the water to other uses and the substitution of beneficial for non-beneficial plants. Maddock (10) stated, "It is simpler to keep water away from saltcedars [a phreatophyte] than to keep saltcedars away from the water."

38. As indicated previously, a very promising method of reducing the evaporation from lakes and reservoirs is by application of a protective film. Crow and Daniel (11) listed the characteristics of a material needed to suppress evaporation effectively without harmful effects:

"(a) It must create film which has great resistance to the movement of water vapor but must not appreciably restrict the free movement of oxygen, carbon dioxide, and other gases through the water surface.

"(b) It must be capable of resisting the action of wind and dust, and must be self-sealing after separation by excessive wind or boats.

"(c) It must be capable of maintaining a compressed monolayer by dispensing molecules at a rate sufficient to overcome losses by wind and biological attrition.

"(d) It must be nontoxic to humans, animals, and marine life."

39. Tests indicate that the most effective compounds for obtaining a film to meet these requirements are the long molecular chain alcohols, hexadecanol, and octodecanol. Research on the use of hexadecanol as an evaporation suppressant was initiated by E. K. Rideal in England in 1925 (12). Research in the United States was started by Langmuir and Schaefer in 1943 (13). A comprehensive bibliography now exists on the use of monomolecular layers for reducing evaporation losses (14, 15, 16) but special mention should be made of the papers by Mansfield (17) and LaMer (18).

40. Hexadecanol and octodecanol are bland, almost odorless, waxy solids produced from animal, vegetable, and marine oils. They are hydrophobic-hydrophilic in character. The OH group at one end of the molecule is attracted by water and the hydrocarbon at the other end is repelled by water, causing the molecules to stand nearly vertical. Provided a sufficient supply of hexadecanol is available, the molecules will continue to be dispensed from the reserve supply until they become closely packed, forming a compressed monolayer. A monolayer is an effective barrier to water vapor only when it is compressed.

41. Laboratory tests of hexadecanol and octodecanol indicate potential reductions of evaporation of 50 percent or possibly more. However, field-scale tests in the United States using hexadecanol indicate water loss reductions of about 10 to 30 percent. Specifically, some field results were 9 percent reduction at Lake Hefner, Oklahoma (19), 14 percent at Sahuaro Lake, Arizona (1960) (20), 8 percent at Lake Cachuma, California (1961) (21), and 43 percent (1957) and 22 percent

(1958) for two lakes in Central Illinois (22).\* The main difficulties encountered in the field use of monomolecular layers are: (a) inefficient application of films (b) maintenance of film (c) biological effects on film. Detailed descriptions of the various techniques developed for application of the film are found in the literature.

42. A major problem during large-scale field tests is the maintenance of the protective film. At Lake Hefner, it was found to be impractical to maintain a film when wind speeds exceeded about 10 m. per sec. The wind also causes loss of film-forming material by piling it on the shore. When the shore lines had steep walls, the protective film tended to re-form. Bacteria will consume the film-forming chemicals at a rate of 0.23 to 0.34 kg per hectare per day (23).

43. A major consideration in the application of a chemical to a reservoir is its effects on quality of water and on fish and other wildlife. The tests at Kids Lake in Oklahoma City (24) resulted in the general conclusion "insofar as criteria of water quality, including taste, odor, color, toxicity, and other chemical qualities are concerned, nothing has been determined from this study to preclude further consideration of Lake Hefner for large-scale evaporation reduction investi-

gations with hexadecanol." A report of subsequent tests at Lake Hefner (19), a water supply reservoir for Oklahoma City, concluded that:

"(a) *Public health aspects.* There were no apparent toxic effects, no undesirable effects on the treatment processes of the lake water, and no interference with normal recreational uses. A large increase in bacterial content of the lake water did occur, but this was not deemed significant.

(b) *Effects on wildlife.* Although long-term ill effects upon wildlife may be forthcoming, no acute toxicity to wildlife was observed during the investigation."

44. In summary, the application and maintenance of monomolecular films on large reservoirs present a number of problems that must be solved before the technique is economically feasible. Thus, this technique for evaporation reduction cannot be expected to contribute to increased water supplies in less developed countries in the immediate future.

45. An interesting recent development has been research to reduce transpiration from crop plants through application of fatty alcohols to soils. Roberts (25) reports that preliminary experiments in Illinois with mixtures of hexadecanol and octadecanol resulted in reduced transpiration with no apparent effect on growth of the plants. However, transpiration control is a controversial subject and some research experiments have ended with negative results. Several research studies on transpiration reduction are currently in progress.

### Artificial Precipitation

46. The subject of rainmaking through the treatment of clouds with nucleating

---

\*The percent reductions reported at these lakes may be noted to be inversely proportional to their sizes. The largest percentages, that is 43 and 22, respectively, apply to two Illinois lakes which have areas of about 2½ acres each. The smallest percentage of 9 percent is for Lake Hefner, which has an area of 22 hundred acres. The other two lakes having intermediate percentages have correspondingly intermediate sizes. (Note supplied by W. B. Langbein, U.S. Geological Survey.)

agents such as dry ice, silver iodide (ice crystal nuclei), hygroscopic particles (condensation nuclei), water sprays, and more recently, artificial electrification of clouds, has been widely investigated over the last decade and a half (26). Experiments are continuing, and only a brief general consensus of the more carefully designed and scientifically conducted experiments completed to date will be given here, together with citations of sources of more detailed information (27, 28, 29, 30, 31, 32, 33).

47. Although cloud modification and precipitation initiation had occasionally been achieved under special conditions, the claims of significant amounts of rainfall reaching the ground, prevalent in the late 1940's and early 1950's, have not been validated. There is emerging evidence, mainly from specially instrumented cloud physics aircraft, use of radar in conjunction with other experimental controls, and cloud-census studies, that the microphysical events in natural clouds which seeding techniques seek to influence, may often proceed at high efficiency for reasons which are not yet completely understood. That is, in a given cloud with rain-making potential, natural rain and snow formation is already underway by the time appreciable condensed moisture is present. Those clouds that might be susceptible to treatment are generally found to be either extremely infrequent (34), or to contain only trivial amount of condensed moisture, when judged in terms of that required for significant quantities of rain to survive evaporation losses between the cloud base and ground. The probability of a given cloud precipitating and the amount of rainfall released appear to be dictated or at least dominated by larger scale atmospheric processes, especially the

structure, vigor, duration, and extent of ascending moist air currents as they influence the lateral and vertical dimensions of cloud systems.

48. The more optimistic theoretical estimates of effects from cloud seeding are now of the order of 10 percent of the amount of increase in rainfall over that expected naturally. Similar decreases cannot be completely ruled out at this time because of both physical and statistical uncertainties. The statistical difficulties of validating such small artificial effects (small relative to the extremely large space and time variation characterizing natural rainfall) is indicated by a recent 4-year series of U.S. experiments over southeastern Arizona (35). Using measured rainfall amounts from a high-density raingage network, it was estimated that well over a half-century might be required to detect a 20 percent effect.

49. In summary, it appears that water supplies from the atmosphere are determined mainly by geography, by climatological factors, and by the large-scale features of atmospheric circulations, and that attempts at artificial modification have not produced consistent economically significant results.

#### **Large-Scale Weather and Climate Modification**

50. In contrast to cloud-seeding, which aims at localized effects, there has been increasing speculation of late into the possibilities of large-scale (individual storms or continental, hemispheric or global scale) modification of weather and climate.

51. Large portions of entire storms, such as hurricanes, have been seeded and although interesting effects were observed on the radar screens, no conclusions could

be drawn as to the effect on the intensity or movement of the storm itself (36). Since hurricanes are prodigious producers of fresh water (Hurricane CARLA was estimated to have caused more than 40 billion metric tons of rain to fall over the Mississippi Valley in one day in September 1961—enough to have supplied the fresh-water needs of the United States for more than 2 months), it is tempting to speculate how to “tame” these storms to be benefactors rather than scourges of humanity. But much more must be learned about their origin and mechanics if Man is to probe for weak spots to exert control of one of these monstrous storms, whose energy is so tremendous that in one day, its winds could, if properly harnessed, provide the electrical energy needs of the United States for 6 months.

52. The present climatic regimes, including distribution of precipitation, are by-products of the large-scale circulations set into motion by unequal heating of the earth's surface by the sun—inequalities introduced by differences in latitude and the thermal contrasts between large land masses and oceans, with the rotation of the earth playing an important role. A rational explanation of the present climatic regimes, starting from basic principles and the particular land-sea configuration and other properties of our planet, has not yet been formulated.

53. One of the most interesting climatic contrasts is that existing in Africa, from the equator northward to latitude  $20^\circ$  where the annual rainfall decreases from 1500 mm. to practically zero. The humid southwest monsoon brings in warm, moist air south of  $20^\circ$  N Lat. in summer, while the hot, dry northeast trade winds cover the area to the north

of this northern tropical front. T. Bergeron (37) has proposed sea-water evaporation factories, powered by atomic energy, to enrich the southwest monsoon with additional humidity which would then be carried with the winds into the interior of Africa, increasing the frequency and amount of rain and at the same time moving the northern tropical front farther north because of the cooler air.<sup>3</sup> The economies or dynamics of this interesting suggestion were not elaborated upon but it is a good example of the sort of proposal that must await the availability of suitable mathematical models to determine its meteorological feasibility.

54. Within the past half-decade, there has been notable progress in developing mathematical models of large-scale atmospheric circulations, which, despite greatly simplified conditions, bear amazing similarities to the real atmosphere (38, 39, 40). On one of these models, basic physical parameters have been varied to observe the effect on the circulation pattern. An interesting result occurred when the poleward gradient in solar radiation was doubled: the number of planetary waves in the circumpolar westerlies thereupon decreased from five to four. This would mean the elimination of an entire family of storms covering a strip of the earth's surface 8 thousand km. by 3 thousand km. Likewise, the halving of the poleward radiation gradient would mean the creation of a new storm system with its attendant precipitation pattern.

55. Despite these theoretical possibilities, no one has suggested practical means of changing the poleward gradient, which Nature does so easily as the sun changes its declination from winter to summer and back to winter. Nevertheless, with

more and more realistic mathematical models of the atmosphere, it may well be that vulnerable spots in the atmospheric cycle, amenable to Man's relatively puny energy and logistic resources, may reveal themselves. When this day comes two cautions must be observed: first, we must be quite sure that the models are accurate

enough to predict that the desired beneficial results and not harmful unexpected changes will come about (41); and second, that whatever is done, is done by international agreement, since such large changes in atmospheric circulations will affect many, if not all, countries of the world.

### FOOTNOTES

<sup>1</sup> Dr. Wexler had completed a revised draft of his section of this paper just before his death on August 11, 1962. His colleagues of the U.S. Weather Bureau believe that the revised draft which is reproduced here substantially expresses Dr. Wexler's intended contribution.

<sup>2</sup> Ion exchange resins and zeolites are used to soften water, but are too expensive for the desalination of even moderately brackish water.

<sup>3</sup> Dr. Bergeron has also written a manuscript, apparently unpublished, entitled, "Possible Future Man-Made Climatic Changes," which was presented before the Department of Meteorology, Imperial College of Science and Technology, London, in early April 1961.

### REFERENCES

- (1) Fox, Sir C. S., *Water*. The Philosophical Library, Inc., New York (1952).
- (2) Ahrens, T. P., *A Reconnaissance Ground-Water Survey of Somalia, East Africa*. Comitato Interministeriale per la Reconstruzione, Rome, Italy. Nov., 1951.
- (3) McCutchan, J. W., *Saline Water Demineralization—A Review and Bibliography*, Report 61-61, Department of Engineering, University of California, Los Angeles (1961).
- (4) American Chemical Society, *Saline Water Conversion*, Advances In Chemistry Series No. 27, Washington, D.C. (1960).
- (5) National Academy of Sciences-National Research Council, *Proceedings of the Symposium on Saline Water Conversion*, Publication No. 568, (1957).
- (6) Annual Reports, Office of Saline Water, U.S. Department of the Interior, Washington, D.C. (1953-1961).
- (7) National Academy of Sciences-National Research Council, *Proceedings of the Desalination Research Conference*, Publication No. 942, Washington, D.C. (1962).
- (8) National Academy of Sciences-National Research Council, *Desalination Research and the Water Problem*, Publication No. 941, Washington, D.C. (1962).
- (9) Meyers, J. S., *Evaporation From the 17 Western States*, Geological Survey Professional Paper 272-D (1962).
- (10) Maddock, T., Discussion of paper, *Consumptive Use and Water Waste by Phreatophytes*, by Harry F. Blaney, Proceedings of the American Society of Civil Engineers, Journal of the Irrigation and Drainage Division, IR2, Part I, 101-105 (1962).

(11) Crow, F. R., E. R. Daniel, *Chemicals for controlling evaporation from open water surfaces*, American Society of Agricultural Engineers, Transactions, 1, 72-75 (1958).

(12) Rideal, E. K., *The influence of thin surface films on the evaporation of water*, Journal Physical Chemistry, 29, 1585-1588 (1925).

(13) Langmuir, I., and Schaefer, U. J., *Rates of evaporation of water through compressed monolayers on water*, Franklin Institute Journal, 235, 119-162 (1943).

(14) U.S. Army Corps of Engineers, *Present Status of Evaporation Reduction by Chemical Films*, Miscellaneous Paper No. 5-475 (1962).

(15) U.S. Geological Survey, *Review of Literature on Evaporation Suppression*, Geological Survey Professional Paper 272-C (1960).

(16) Reidhead, R. D., Jr., *Evaporation and Evaporation Suppression Bibliography*, Water Bulletin No. 6, Department of Resource Development, Michigan State University (1960).

(17) Mansfield, W. W., *Influence of monolayers on the natural rate of evaporation of water*, Nature, 175, 247-249 (1955).

(18) LaMer, V. K., *The Physical Chemical Basis of Water Evaporation Control by the Monomolecular Film Technique*, Proceedings First International Conference on Reservoir Evaporation Control, San Antonio, Texas. April 14, 1956. Southwest Research Institute.

(19) U.S. Geological Survey, *Water-Loss Investigations: Lake Hefner 1958 Evaporation Reduction Investigations*, Report by the collaborators (June 1959).

(20) U.S. Bureau of Reclamation, *1960 Evaporation Reduction Studies at Sahuaro Lake, Arizona, and 1959 Monolayer Behavior Studies at Lake Mean, Arizona—Nevada and Sahuaro Lake, Arizona*, Chemical Engineering Laboratory Report No. SI-32 (August 1961).

(21) U.S. Bureau of Reclamation, *Water-Loss Investigations: Lake Cachuma—1961—Evaporation Reduction Investigations*, Chemical Engineering Laboratory Report No. SI-33 (January).

(22) Roberts, W. J., *Reducing lake evaporation in the Midwest*. Illinois State Water Survey, Circular 76, 1959. Reprinted from Journal of Geophysical Research, 64, 1605-1610 (1959).

(23) Franzini, J. B., *Evaporation Suppression Research*. Water and Sewage Works (Journal) Part I: 108, 167-172 (May 1961); Part II: 108, 221-225 (June 1961).

(24) U.S. Bureau of Reclamation, *Water Quality Studies with Hexadecanol, Kids Lake, Oklahoma City, Oklahoma. Preliminary Evaporation-Reduction Studies—Lake Hefner, Oklahoma City, Oklahoma*, Report of the Committee of Collaborators, Commissioners Office, U.S. Bureau of Reclamation, Denver, Colorado (April 1957).

(25) Roberts, W. J., *Reduction of transpiration*, Journal of Geophysical Research, 66, 3309-3312 (1961).

(26) American Meteorological Society, *Bibliography on Weather Modification*, Meteorological and Geostrophysical Abstracts, 11, Part III, Boston, Massachusetts (1960).

(27) World Meteorological Organization, *Final Report of the Working Group on Clouds and Hydrometeors*, Appendix B, CAe-III/Doc. 7, Commission for Aerology, Third Session, Rome (1961).

(28) Petterssen, S., et al., *Cloud and Weather Modification: A Group of Field Experiments*, Meteorological Monographs, 2, American Meteorological Society, Boston, Massachusetts (1957).

(29) McDonald, J. E., *The physics of cloud modification*, *Advances in Geophysics*, 5, Academic Press, Inc., New York, 223-303 (1958).

(30) Stout, G. E., W. E. Bradley, *Evaluation of Electric Charges Induced in the Atmosphere*, Final Report to the National Science Foundation, Illinois State Water Survey Meteorological Laboratory (December 1, 1961).

(31) Union Geodesique et Geophysique Internationale, *International Conference on Cloud Physics*, Australia, September 1961, Monograph No. 16, Paris (1962).

(32) Braham, R. R., *Physical properties of clouds*, Journal of the Irrigation and Drainage Division, Proceedings of the American Society of Civil Engineers, Part I, 86, 111-119 (1960).

(33) Smith, T. B., *Physical studies of the Santa Barbara cloud-seeding project*, Journal of Applied Meteorology, 1, 208-217 (1962).

(34) Jones, R. F., *Layer cloud over Southern England*, Quarterly Journal of the Royal Meteorological Society, 87, 65-71 (1961).

(35) Battan, L. J., A. R. Kassander, *Evaluation of effects of airborne silver iodide seeding of convective clouds*, Scientific Report No. 18, The University of Arizona Institute of Atmospheric Physics (March 1, 1962).

(36) Simpson, R. H., *Hurricane Esther—something old, something new*, given at Washington, D.C. Branch of the American Meteorological Society (October 18, 1961). (A brief description of the results appeared in U.S. Department of Commerce Weather Bureau Press release WB 61-16 (4 October 1961).

(37) Bergeron, T., *Possible man-made great-scale modifications of precipitation climate in Sudan*, Physics of Precipitation, American Geophysical Union Monographs, 5, 399-401 (1960).

(38) Phillips, N. R., *The general circulation of the atmosphere: A numerical experiment*, Quarterly Journal, Royal Meteorological Society, 82, 123-164 (1956).

(39) Smagorinsky, J., *General-Circulation Experiments with the Primitive Equations, Part I: The Basic Experiment*, Monthly Weather Review (to be published).

(40) Greenfield, S. M., et al., *A Rational Approach to Weather-Control Research*, Final Report, Memo RM-3205-NSF, RAND Corporation, Santa Monica, California (May 1962).

(41) Wexler, H., *Modifying weather on a large scale*, Science, 128, 1059-1063 (1958).

# Education in Hydrology\*

JOHN W. HARSHBARGER

*Head, Department of Geology, University of Arizona, Tucson, Arizona*

1. The growing importance of development and intelligent management of water supplies for mankind has created an urgent world-wide need for scientifically trained hydrologists.

2. In recent years, many water problems are being amplified by a rise in man's standard of living, increased production of food and industrial products, and settlement of previously undesirable regions. Thus, water problems are directly related to such things as: (a) increase in population, (b) geographic shifting of population centers, (c) more water-use per capita, (d) deterioration of watersheds and a decrease of perennial water, (e) pollution of streams and lakes by man's wastes, and (f) occupation of semiarid regions.

3. But the water challenge is not limited to desert areas. Intensive development in certain areas where water is plentiful has created severe problems. Supplies adequate in past years are no longer usable. Man's occupation in certain watersheds has increased destruction by floods; sediment from increased erosion clogs drainageways; streams and lakes are polluted by industry and cities. In some areas, inadequate drainage and increased salinity have brought about the loss of arable lands.

4. Many of these problems caused by man cannot be solved by the mere application of money, concrete, and labor. Throughout the world, sheer lack of knowledge, of understanding, still impedes the making of sound water development plans on a scientific basis. As the competition for known water supplies becomes ever more keen, the deficiency in basic knowledge of hydrologic principles becomes progressively more serious. Today, in the resolution of late-stage water developments, the margin of error permissible in initial stages cannot be tolerated.

5. The production of well-trained hydrologists, therefore, must have high priority throughout the world, if man's hope of obtaining optimum benefit of the water resources available is to be fulfilled.

6. In this effort, colleges and universities have an indispensable role to play, because the kind of broad education needed can be efficiently given only by them, and because of their traditional interest in basic aspects of the sciences. As hydrology is an interdisciplinary science, it requires the talents and skills of a variety of fields. The water specialist must be well trained in mathematics, physics, chemistry, meteorology, geology, hydromechanics, and agricultural sciences. In addition, he must have a

\*U.N. Conference paper.

knowledge of economics, social sciences, and law. The training of such persons presents difficult problems to the educational institution attempting to design appropriate programs.

7. The importance of research and advanced training cannot be overstressed. Much necessary insight is still to be gained in the many processes of the water cycle. The attraction of talented students to rigorous training programs requires substantial financial assistance; otherwise, the objectives cannot be attained. As many nations experiencing problems in water resources do not have trained hydrologists or educational facilities, international as well as national programs are essential.

8. Furthermore, international cooperation in promoting knowledge of water resources is called for by the very nature of the subject. As R. L. Nace of the U.S. Geological Survey states in his discussion of *A Plan for International Cooperation in Hydrology* (1):

"No nation occupies an entire continent. (The subcontinent of Australia is an imperfect exception). No continent has a closed hydrologic system, but each is a part of a global system. Therefore, no nation can learn by itself, within its own boundaries, all that it must know about water and the hydrologic cycle. None can completely learn even its own local water balance within the continental system \* \* \* Cooperation among nations is required, so the task is international."

### The Scope of the Science of Hydrology

9. The science of hydrology promotes sound economic development by making possible a realistic understanding of man's hydrologic environment. There

are many concepts and definitions of hydrology, but one most suitable for our purpose is from *Scientific Hydrology* (2):

"Hydrology is the science that treats of the waters of the Earth, their occurrence, circulation, and distribution, their chemical and physical properties, and their reaction with their environment, including their relation to living things. The domain of hydrology embraces the full life history of water on the Earth."

10. Under this broad definition, the science includes understanding of the earth's physical features and the mechanics of its atmospheric systems. Man's social and economic requirements for management of water resources are to be related to the total hydrologic environment.

11. An adequate description of the global water cycle is still needed to define the circulation of water on the earth as a whole. The nucleus of hydrology lies in the earth sciences. The unifying concept is the hydrologic cycle. The cycle begins and ends with the world ocean and involves the transport of water from sea to air, and from air to land. Here, it may be stored for short or long periods, after which it moves in surface streams or through the earth's porous rocks as ground water back to the sea. In this transitional movement, water passes through the gas, liquid, and solid states. It leaves the sea essentially pure, but during its transit dissolves many inorganic and organic compounds as it passes through one or several biological systems. Further, it erodes the earth's rocks, changes the continental profile, and returns to the sea laden with many minerals and with man's wastes. The quantitative water budget of the oceans and continents, and the dynamics of

water vapor in the atmosphere, need to be better understood. The horizontal transport of water vapor in the atmosphere as well as the precipitable water must be evaluated to obtain the net influx of water vapor to areas of water need. The water balance of the globe requires more attention than heretofore for the sake of better understanding of the terrestrial phase of the hydrologic cycle.

12. There still are major gaps in the basic data necessary to adequately explain the distribution of water on the globe. For example, the magnitude of the North African aquifer is not known, and as yet no discharge measurements have been made on the Amazon, the world's largest river. There are vast desert, tropical, and polar regions of variable climate for which there are no hydrologic data. Such regions are of tremendous significance for a global analysis of the water budget.

13. As a complement to these physical and biological aspects, the hydrologist should have knowledge of factors that bear on water management. Comparative and quantitative studies of water management techniques, as influenced by climatic variability, water distribution, land use, and economics, are called for. Legal, social, and ethnologic characteristics have a large bearing on the devising of acceptable water projects for mankind. Historically, hydrology has been more empirical than theoretical, but the time has come when hydrology must become fully a science.

#### **Recent Developments in Hydrology Education in the United States**

14. The world over, many programs for improving economic and social conditions hinge on water resources. But

the skills to design and manage proposed projects fall far short of the growing demand for them. In the United States, also, despite a long concern for progressive water development, the supply of trained men is inadequate in many respects. In the last several years, many scientists, and governmental agencies in the water field, both state and national, have expressed concern. Only a few educational institutions in the United States have long experience in offering some basic courses in hydrology, which comprise the formal academic training of today's senior hydrologists. Prior to 1960, less than 60 major universities listed hydrology courses in their catalogs and only 14 of these were offered at a graduate level. A special panel on the matter of training reported that, as of 1960—there were perhaps only five or six universities which offered anything approaching a program of advanced study in hydrology.

15. In August, 1962, an Inter-University Conference on Hydrology was convened by the University of California, Los Angeles, with representatives from 19 universities, 8 federal (national) agencies, and the American Geophysical Union. The participants were of unanimous opinion that there is a critical shortage of suitably trained men in all aspects of hydrology and that universities are obligated to develop adequate educational programs. The group also agreed that much more research in the water field at universities is needed to strengthen training programs at the graduate (advanced) level.

16. But even before the Conference expressed this consensus, some half-dozen universities had announced broader programs in hydrology for the 1961-1962 academic year. Most of them are designed for graduate training, and are

interdisciplinary in that courses of instruction offered by several departments are integrated. The programs differ somewhat depending upon the advanced degree; the degrees given are usually in a specific departmental area. New techniques in statistics, operations research, and systems engineering are some of the powerful tools which are now being taught. (One university in the southwest, the University of Arizona, offers both undergraduate and graduate degrees in hydrology. An incomplete survey of the courses now being offered in colleges and universities in the United States is given in Annex B.) Requirements for entrance to these programs include substantial background in mathematics, physics, chemistry, hydro-mechanics, and geology.

17. In the academic year 1962-63, other American colleges and universities began to integrate course offerings in the broad field of water resources. Thus, there are now about 20 institutions in the United States which are striving to make hydrology, as a scientific discipline, comparable

to other physical sciences. Most of these are state universities located in the western half of the country; others are in the "Middle West" and the coastal areas of the east. This recent intense effort, which benefits from active cooperation among universities, is a significant development in education.

#### **Training for Students of Other Nations**

18. Many students from other nations are already studying hydrology and related fields in the United States. With the growth of the newer programs described above, more opportunities are becoming available to students from abroad.

19. The study of hydrology, a science that is literally global in scope, calls for international exchange of knowledge regarding one of man's essential resources. Improved educational and training facilities, in the United States as in other countries, will contribute to the better solution of water problems throughout the world.

#### **Annex A. Study in Hydrology and Related Fields at the University of Arizona**

20. To provide an integrated program in hydrology in American universities usually requires special interdepartmental arrangements. The experience of the University of Arizona is of interest.

21. This University initiated in 1961 a new program in scientific hydrology which provides broad training in basic sciences and a rigorous synthesis of hydrologic systems. The program includes undergraduate and graduate curricula leading to Bachelor of Science, Master of Science, and Doctor of Philosophy in Hydrology. It includes basic courses in mathematics, physics, chemistry, geology, meteorology, hydrome-

chanics, botany, economics, and social sciences.

22. Eight new hydrology courses at the graduate level deal with scientific principles and systems analyses of the many hydrologic interrelationships. The graduate program is open to students holding degrees in other fields such as civil engineering, geology, soils meteorology, and agriculture. Prior study in hydrology is not required provided certain requirements are met: differential equations, general chemistry and physics, physical and historical geology, fluid mechanics, botany or biology, economics, engineering drawing and data analysis,

field techniques, surveying, and geologic mapping.

23. The hydrology program is guided by a committee of representatives from the participating departments. The committee, acting in lieu of a departmental faculty, recommends acceptance or denial of applications, advises students, develops and approves graduate study programs, approves research topics and directors, and suggests examining committees.

24. In connection with this new program, it is also of interest to mention some other significant activities of the university which concern water resources.

25. The University of Arizona has achieved a recognized position in arid-land and water studies owing in part to its location in the arid southwest. Emphasis on teaching and research in hydrology naturally varies from department to department but the exceptional scope of the University's work in this and related fields is seen in activities outlined as follows:

26. The Institute of Atmospheric Physics conducts research in behalf of basic knowledge of the weather and climate of Arizona, of the southwest, and of arid regions of the earth in general. The Institute views the problem of water in an arid land as the fundamental one, and studies aspects such as the regional flux of water vapor, microphysical properties of water particles in the clouds, etc.

27. Many studies relating to water are done in the College of Agriculture. The Department of Agricultural Engineering has collected over many years material of exceptional significance for hydrology, such as full historical records of ground water basins. Closely related to this

work is the determination of transmissibility and specific yield of water bearing formations.

28. The Institute of Water Utilization is involved in fundamental and applied research relating chiefly to development, conservation, and utilization of water resources under semi-arid and arid climatic conditions. A major subject of research is artificial recharge, related to the ground-water supply in Arizona. The Department of Watershed Management is concerned with methods for wildland watersheds which will produce optimum yields of water and other products coincident with satisfactory flood and erosion control. Investigations of transpiration rates of various plants are being made with the aim of manipulating vegetation for maximum water yield.

29. Soil water and water quality are the special concern of the Department of Agricultural Chemistry and Soils. The Department is also conducting research into the movement of water and nutrients through soil and into plants.

30. The Department of Agricultural Economics deals with such matters as the pricing of water, the patterns of watershed development and land use, structures of water law, and water regulatory organization.

31. The interests of the Department of Civil Engineering lie in conception, design, construction, and operation of water development projects. Recent research includes the hydraulics of long culverts and of partially full flow in conduits of various shapes.

32. The Geochronology Laboratories studies problems to do with occurrence and movement of water during geologic history.

33. The Laboratory of Tree-Ring Re-

search is an important supporting unit for the hydrology program, with its studies on the relation between environmental parameters and the radial growth

of trees. There are strong indications that variations in width of tree-rings reflect variations in precipitation and streamflow during the past 5,000 years.

**Annex B. Titles of courses in hydrology and closely related areas offered by educational institutions in the United States**

*Dealing chiefly with physical factors*

- \*Hydrology
  - Ground water hydrology
  - \*Surface water hydrology
  - \*Field hydrology
  - \*Land mass hydrology
  - \*Watershed hydrology
  - \*Hydrologic systems
  - \*Dynamics of flow systems of the earth
  - \*Quantitative determination of aquifer performance
  - \*Geology of ground water
  - \*Fluid mechanics
  - \*Hydrodynamics
    - Flow in porous media
    - Free surface flow
  - \*Hydraulics of open channels
  - \*Hydraulic engineering
    - Flood control hydrology
  - \*River hydraulics
    - Water power engineering
    - Coastal engineering
    - River-harbor engineering and hydraulics
  - \*Irrigation hydraulics
    - Drainage of agricultural lands
    - Seepage and earth dams
  - \*Meteorology
    - Hydrometeorology
  - \*Physical and dynamical meteorology
  - \*Physical climatology
  - \*Arid zone agroclimatology and micro-meteorology

\*Courses offered in hydrology programs at the University of Arizona, Tucson.

*Dealing chiefly with physical factors—  
Continued*

- \*Physics of soil water
  - Glacial geology
  - Permafrost
  - Fluvial geomorphology
  - Hydrodynamics of sediment transportation
  - Limnology
  - Oceanography
- \*Water quality and geochemistry
- \*Quantitative geomorphology
- \*Analog model analysis of hydrologic systems
- \*Statistical hydrology
  - Applied statistics in hydrology
  - Application of digital computers to hydraulics and sanitary engineering problems

*Dealing chiefly with biological factors*

- \*Forest influences on watershed management
- \*Plant-water-soil relationships
- \*Dendrohydrology
  - Hydrobiology
- \*Water supply and waste water disposal
- \*Principles of sanitary engineering
  - Water pollution control
  - Chemistry of water purification and sewage treatment
  - Atmospheric pollution
- \*Industrial wastes
  - Disposal of radio-active wastes

*Dealing chiefly with economic and social factors*

\*Water utilization

\*Appraisal and development of water supplies

Principles of watershed management

\*Watershed programs, administration and policy

\*Courses offered in hydrology programs at the University of Arizona, Tucson.

*Dealing chiefly with economic and social factors—Continued*

Wildland hydrology

\*Irrigation management and water conservation

Water institutions and economics

Economics of water resources

\*Water law

Human ecology

\*Land economics

#### REFERENCES

(1) A Panel of Hydrologists (U.S.A.), *A Proposal and Plan for International Cooperation in Hydrology*, Bull. Inter. Assoc. Sci. Hydrol., 6, p. 11 (1961).

(2) Ad Hoc Panel on Hydrology, W. B. Langbein, Chairman, *Scientific Hydrology*, Federal Council for Science and Technology, Washington, D.C. (June 1962).