

JPRS 71289

13 June 1978

TRANSLATIONS ON TELECOMMUNICATIONS POLICY,
RESEARCH AND DEVELOPMENT

No. 40

DISTRIBUTION STATEMENT A
Approved for Public Release
Distribution Unlimited

Reproduced From
Best Available Copy

20000621 002

U. S. JOINT PUBLICATIONS RESEARCH SERVICE

REPRODUCED BY
**NATIONAL TECHNICAL
INFORMATION SERVICE**
U. S. DEPARTMENT OF COMMERCE
SPRINGFIELD, VA. 22161

DTIC QUALITY INSPECTED 4

121

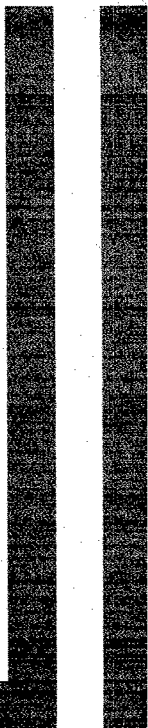
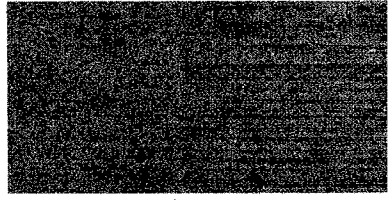
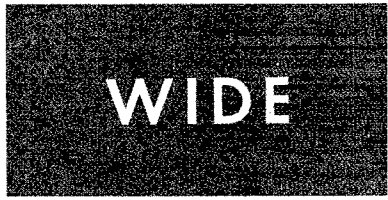
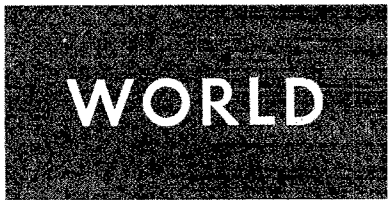

NOTE

JPRS publications contain information primarily from foreign newspapers, periodicals and books, but also from news agency transmissions and broadcasts. Materials from foreign-language sources are translated; those from English-language sources are transcribed or reprinted, with the original phrasing and other characteristics retained.

Headlines, editorial reports, and material enclosed in brackets [] are supplied by JPRS. Processing indicators such as [Text] or [Excerpt] in the first line of each item, or following the last line of a brief, indicate how the original information was processed. Where no processing indicator is given, the information was summarized or extracted.

Unfamiliar names rendered phonetically or transliterated are enclosed in parentheses. Words or names preceded by a question mark and enclosed in parentheses were not clear in the original but have been supplied as appropriate in context. Other unattributed parenthetical notes within the body of an item originate with the source. Times within items are as given by source.

The contents of this publication in no way represent the policies, views or attitudes of the U.S. Government.

PROCUREMENT OF PUBLICATIONS

JPRS publications may be ordered from the National Technical Information Service, Springfield, Virginia 22151. In ordering, it is recommended that the JPRS number, title, date and author, if applicable, of publication be cited.

Current JPRS publications are announced in Government Reports Announcements issued semi-monthly by the National Technical Information Service, and are listed in the Monthly Catalog of U.S. Government Publications issued by the Superintendent of Documents, U.S. Government Printing Office, Washington, D.C. 20402.

Indexes to this report (by keyword, author, personal names, title and series) are available through Bell & Howell, Old Mansfield Road, Wooster, Ohio, 44691.

Correspondence pertaining to matters other than procurement may be addressed to Joint Publications Research Service, 1000 North Glebe Road, Arlington, Virginia 22201.

BIBLIOGRAPHIC DATA SHEET		1. Report No. JPRS 71289	2.	3. Recipient's Accession No.
4. Title and Subtitle TRANSLATIONS ON TELECOMMUNICATIONS POLICY, RESEARCH AND DEVELOPMENT, No. 40			5. Report Date 13 June 1978	
7. Author(s)			6.	
9. Performing Organization Name and Address Joint Publications Research Service 1000 North Glebe Road Arlington, Virginia 22201			8. Performing Organization Rept. No.	
12. Sponsoring Organization Name and Address As above			10. Project/Task/Work Unit No.	
			11. Contract/Grant No.	
15. Supplementary Notes			13. Type of Report & Period Covered	
			14.	
16. Abstracts This serial report contains translations from the world press and radio relating to worldwide political, economic and technical developments in telecommunications, computers, and satellite communications. Coverage will be worldwide with focus on France, Federal Republic of Germany, United Kingdom, Italy, Japan, the USSR, People's Republic of China, Sweden, and the Netherlands.				
17. Key Words and Document Analysis. 17a. Descriptors Worldwide Computers Satellite Communications Electronics and Electrical Engineering Telecommunications Telemetry				
17b. Identifiers/Open-Ended Terms				
17c. COSATI Field/Group 09B, C, F, 17B, 22B				
18. Availability Statement Unlimited Availability Sold by NTIS Springfield, Virginia 22151			19. Security Class (This Report) UNCLASSIFIED	21. No. of Pages 121
			20. Security Class (This Page) UNCLASSIFIED	22. Price PC Aφ6

CONTENTS (Continued)	Page
ROMANIA	
Electronics Expert Discusses TV Transmission by Satellite (Alexandru Spataru Interview; VIATA STUDENTEASCA, 22 Mar 78)	35
YUGOSLAVIA	
New International Telephone Exchange Opened in Ljubljana (DELO, 26 Apr 78)	39
Metaconta 10-C Automatic Exchange in Operation, by Ilija Bregar Dedication Speech by Zvone Dragan Metaconta 10-C Operating Details	
SUB-SAHARAN AFRICA	
CONGO	
Satellite Telecommunications Ground Station Opened (LA SEMAINE AFRICAINE, 7 May 78)	44
GHANA	
Briefs	
Pan African Telecommunications	50
SOUTH AFRICA	
Computer Industry Developments, Future Detailed (SUNDAY TIMES, 21 May 78)	51
Competitive Market, by Peter Godsell Staff Shortage Sanctions Ineffective	
Briefs	
Record Sales for ICL	55
USSR	
Current Broadcasting Developments and Goals Discussed (Ye. Ye. Dobrovol'skiy; VESTNIK SVYAZI, Apr 78)	56
Practical Applications of Soviet Comsat System (V. M. Tsirlin, V. P. Dmitriyev; VESTNIK SVYAZI, Apr 78)	66

CONTENTS (Continued)	Page
Briefs	
New Television, Radio Station	70
WESTERN EUROPE	
FRANCE	
PTT's 1976 Activities, Finances Reviewed (REVUE DES PTT DE FRANCE, No 1, 1978)	71
SWITZERLAND	
Swiss Participation in Weather Satellite Planned (NEUE ZUERCHER ZEITUNG, 10 May 78)	99
UNITED KINGDOM	
Business Policy, Organization of Post Office Detailed (K. Gowen, D. Loosemore; REVUE DES PTT DE FRANCE, No 1, 1978)	101

IBM, JAPANESE COMPUTER INDUSTRY

Tokyo INDUSTRIA in English Vol 8 No 5, May 78 pp 6-10

[Text]

NEC-Toshiba Group Strengthens Cooperation

On February 25, 1978, the Japanese computer industry rocked all day long with one topic.

On that morning Japanese newspapers reported that Tokyo Shibaura Electric Co., Ltd. (Toshiba) would separate its business division for large and medium-size computers from the company. One paper headlined: "Toshiba is withdrawing from large computer business." The point of the news was that "Toshiba and Nippon Electric Co., Ltd. (NEC) agreed that Toshiba's sales division for large and medium-size computers would be transferred to NEC-Toshiba Information Systems Inc. (NTIS), their joint venture for the development of Very Large Scale Integration circuits. The news shocked the computer industry, because the agreement practically means that Toshiba, ranking fourth among Japanese computer makers, will withdraw from the large and medium-size computer market, and because it could mean limitation in the development of the domestic computer industry with support from the Ministry of International Trade and Industry (MITI)."

Stunned by the word "withdrawal," Toshiba filed a protest with the newspaper which had reported the news. President Kazuo Iwata of Toshiba said, "That's not withdrawal but an advance." Supporting the latest decision, MITI described it as "stepped-up cooperation in marketing between Toshiba and NEC." NEC, the partner of cooperation, also aired "stepped-up cooperation," saying that "weakening of Toshiba would mean that NEC would also get weakened."

More time is needed to know the credibility of the news. The top management of Toshiba was apparently looking for an opportunity to announce a plan to separate the business division for large and medium-size computers. Since Toshiba emphasizes that it will continue to be a "main-framer," it is inconceivable for Toshiba to withdraw from all fields of large computers, including the development and manufacture in the near future. However, it can not be denied that Toshiba, in reaching the latest decision, read coolly the diversifying trends in demands for computers as represented by the distributed processing system, in addition to the chronic deficit in the large computer business.

The latest news seems to have provided a chance for computer makers to "move." There prevails the view that the Japanese computer industry has entered the era of "Domestic Big Three," namely Fujitsu Ltd., Hitachi, Ltd. and NEC, following that of "three groups, six makers."

Domestic Mainframers Doing Well

It was in 1961 that Japan's computer production took the form of an industry. Recognizing the importance and the future of computer, the Government had been considering for many years the introduction of computer technology from the United States. Against this backdrop, the Government asked International Business Machines Corp. (IBM) to open its patents for computers in exchange for approval of its computer production in Japan.

It was in January, 1961, that IBM made its basic patents public in Japan, opening the way for Japanese manufacturers to turn out computers on their own. In other words, the Japanese computer industry would not have existed without IBM. Ever since then, domestic computer makers have continued business, constantly recognizing the existence of IBM.

The Government envisioned a plan to establish a computer company which would pursue its policy. MITI tried in vain to consolidate into a national policy company six manufacturers (three general electric makers - Hitachi, Toshiba, Mitsubishi Electric Corp. and three communications equipment makers - NEC, Fujitsu, Oki Electric Industry), because it thought the six companies were too many to develop large scale computers and compete with IBM. But this plan did not materialize in the face of stiff opposition from all the manufacturers.

MITI's next protective measure was to subsidize the computer industry for research and development. Subsidies provided for development during the 1972-77 period totaled approximately ¥70,700 million. This amount, however, was considerably small, compared with IBM's investment in research and development.

The Government has considered it wise to concentrate subsidies on a group as small as possible in order to effectively compete with IBM, and begun secret moves to re-organize the computer industry. Consequently, three groups were formed during the period between October and November, 1971. They were the Fujitsu-Hitachi Group, Mitsubishi-Oki Group and Toshiba-NEC Group. Even after the reorganization, the Government tried to delay the liberalization of computer imports and of foreign investment in the computer industry as long as possible with a view to strengthening the competitiveness of the domestic manufacturers. All these government efforts came from the determination to prevent the "Giant IBM" from dominating the domestic market and the recognition of the importance of the information industry.

During this period, however, IBM (in fact, IBM Japan, Ltd., totally owned by IBM of USA) had gone its own way in Japan, paying little attention to Japanese manufacturers. But the share of IBM in the Japanese market continued declines, contrary to its expectation. Domestic computer makers have demonstrated their strength competitive with IBM and other foreign manufacturers, by marketing a series of new products, since imports and foreign capital investments were liberalized in December, 1975.

'Gulliver - IBM' Stands Up

In Japan there are eight computer manufacturers at present. They are the already-mentioned six domestic makers, IBM Japan and Nippon Univac Kaisha, Ltd. In addition to these, National Cash Register, Burroughs, Control Data Corp. (CDC) and other firms are marketing imported products.

According to available statistics for 1976, the output of computers and related products totaled ¥617,000 million, up 14.0 percent over the previous year. Reliable sources say the 1977 output increased by about ten percent over 1976, while the total amount of installation showed only a slight increase (the amount for 1976 was ¥731,528 million of which domestic products accounted for 57.5 percent). The discrepancy, as some industry sources note, reflects a situation in which manufacturers are forced to cut prices to survive fierce competition.

Under these circumstances, the mainframers, including Nippon Univac, have come to harbor a common recognition since last year that "IBM of today is no longer like the one in the past." To be sure, IBM had been carefree, going its own way in the past. But IBM has turned ominous, aimed at the Japanese market. It appears that "Gulliver - IBM" has finally stood up.

For IBM, which holds 60 percent of the world's computer market, the Japanese market is less than ten percent of its total share. IBM Japan says, "IBM is not a share-oriented business." However, it may be proper to take that the statement is a comment from someone conscious of the Japanese Anti-Monopoly Law. The only thing IBM is afraid of is possible violation of the anti-monopoly law. The U.S. fair trade act is directed only at unfair competition, such as obstruction of

business or dumping. Under the Japanese law, however, it would be considered as a monopolistic state if a business held a market share of more than 50 percent.

IBM Japan was thought to have a market share of 30 to 35 percent five years ago. But its market share is now estimated at about 26 percent. If the Japanese market is really promising for future expansion, as IBM says, it will be natural for IBM to exert efforts to recover its "lost land."

The offensive by IBM began with the announcement of a series of new products and price reduction. It made public IBM-3033 in March, 1977, and IBM-3031 and IBM-3032 in October, 1977. They are of the IBM 370 series and have internal data processing capacities of 1.6 to three times those of the conventional models. At the same time, it carried out rate cuts ranging from six to 35 percent on the pretext of establishing worldwide unified rates. This series of moves by IBM inflicted damage on domestic producers. Especially, the rate reduction which centered on purchase prices served as a strong rolling-back operation to domestic manufacturers. This is because they had pursued a policy of replacing IBM products with their own by putting up the sales point that the cost performance of their products is 30 percent higher than that of IBM. In other words, their competitiveness in price weakened. Furthermore, it became difficult for domestic users to replace IBM products with Japanese products, since many of businesses using rental IBM products had purchased them.

Since the beginning of the year there had been a rumor within the computer industry that IBM would announce shortly a new series of medium-size products. This was proved correct by the announcement on March 10 that IBM would cut

prices of four medium-size models. It is reported to be an "E Series." This series, when marketed, will probably deal a heavy blow to domestic manufacturers again. Has IBM really begun taking these measures especially to cope with Japanese manufacturers?

Fujitsu "Runs at Full Speed" in Computer Business

IBM Japan is well known for its total secrecy. Its balance sheets have been made public for the past five years, and annual sales circulating the business community are nothing more than presumed figures. The president and other executives rarely speak publicly of their business, as though they were manipulated by "invisible hands from New York." Therefore, we can not get any comment on the latest moves. But IBM itself admits that its view about Japan has changed.

Five years ago, T. J. Watson, then Board Chairman of IBM, told a shareholders meeting that IBM Japan was doing very well and that its future was promising. At a similar meeting last year Chairman F. T. Cary referred to Japan and said that Japan was as highly competitive a market as the United States and Europe. This change in tone may show the change in IBM's recognition of the Japanese market.

Some people of the industry say Fujitsu probably has a view different from other makers as to the IBM offensive on the Japanese market. Fujitsu is affiliated with Amdahl Corp., a plug-compatible mainframer, which is successfully emulating with IBM machines on the American market. They argue that IBM, which regards Amdahl as a "new enemy" in the American market, sets Fujitsu as its target of offensive in Japan, since Fujitsu is a major shareholder of Amdahl (28.7 percent), pursuing the same business policy as Amdahl.

One source of this contention is that the software developed jointly with Hitachi for FACOM M Series is said to have the same functional capacity as that of IBM. Putting up this for a sales point, Fujitsu has made an all-out effort to erode IBM users since the liberalization of the computer industry, spearheading the campaign to replace IBM products with domestic ones. Fujitsu is a leading communications equipment manufacturer which started out as a telephone maker, and there is no change in this status. However, the computer business now accounts for 72 percent of its total sales, and it may be considered to be the only specialized computer maker in Japan. It tops domestic makers with a market share of 19 to 20 percent, and is approaching that of IBM. Fujitsu is staking its future on computers as seen in an executive's statement that Fujitsu is "running at full speed and it will collapse if it stops running."

The trouble of Fujitsu's computer business is that it has to run constantly to expand the scale of sales. This is because the business division stands first among the six domestic computer manufacturers and because it also relies heavily on the rental assets of Japan Electronic Computer Co., Ltd. (JECC), a specialized computer rental company. Last year Fujitsu established a subsidiary for the lease of small computers which are not handled by JECC. But Fujitsu continues heavy dependence on JECC because it mainly turns out large and medium-size computers.

JECC serves like Computer Leasing Ltd. (CLL) of Britain, a subsidiary of International Computers Ltd. (ICL), and Commercial Credit Co. (CCC) of USA, a subsidiary of Control Data Corp. (CDC). Established in 1962, it is owned jointly by the six domestic computer makers. Low-interest loans from government-financed institutions

form JECC's rental funds which have helped greatly domestic makers short of funds.

JECC now rents 125 computer models. When a provisional contract is made on a rental between the manufacturer and the user, the computer is sold to JECC and then put out to rent. Therefore, the manufacturer can put the product on the sales list and get it paid immediately. This is a big merit for manufacturers, but there is a pitfall.

For example, annual sales of IBM Japan are estimated at ¥300,000 million which may be considered a net amount, since IBM Japan rents its products on its own without relying on external sources and carries actual earnings on the book. On the other hand, Fujitsu with annual sales of about ¥240,000 million carries the total amount of a rental contract on the book, even if it is paid over a period of more than one year. In other words, IBM Japan has a large amount of rentals coming in automatically.

For the above-mentioned reason, Fujitsu needs to seek large-scale business and tends to cut prices to expand sales. This business behavior could be posing a growing obstacle to IBM.

Hitachi Holds the Key to Moves of Domestic Makers

Hitachi, ranking second among the domestic computer makers, is Japan's largest heavy electric machinery producer having annual sales of ¥1,300,000 million and also one of the largest manufacturing firms in Japan. The computer business accounts for around 13 percent of the total sales. The dominant view within industry circles, including those with foreign capital investment, is that "Hitachi will not aim at a specialized computer manufacturer." However, there is a view that Hitachi holds the key to future moves of the domestic manufacturers, since it is superior to

others in total computer technology, being especially strong at semiconductor techniques. Its market share is about 15 percent, still below that of Fujitsu. Some firms with foreign capital investments holds the view that Hitachi will be more menacing than Fujitsu in the future.

Hitachi's HITAC M Series incorporates a unified architecture developed jointly with Fujitsu. But they are now at odds as widely known within industry circles. So, there is no prospect of forming a group as in the case of Toshiba and NEC. Having contributed greatly to the development of the nation's computer industry, both have confidence in their computer business and have their own established policies.

Hitachi now earns 50 percent of its computer sales through its own rental system like that of IBM. It is reported that Hitachi has switched to the rental system of its own after having recognized that dependence on JECC's funds is financially unhealthy. The JECC rental system not only results in consuming future sales but also reduces profits. Under the system (in many cases), the computer is directly returned to its manufacturer, when the rental contract is terminated before its completion. In such cases, the manufacturer must buy it back at a price after depreciation. This means the difference in the two prices will be a loss in sales. Some highly rate Hitachi's own rental system, saying that "big business as it is" or that "the management really knows the computer business."

The last of Japan's Big Three is Nippon Electric. Although NEC was once the nation's biggest computer maker, it now ranks third with the market share of about 12 percent. It turns out ACOS 77 Series, a full-line system developed jointly with Toshiba, which has a high cost performance.

NEC "pursues business policies aimed at IBM and has no intention of becoming a specialized maker." (Computer now accounts for 25 percent of its total sales.) It established a wholly-owned local venture for computer business in the United States last year and plans to export small computers, starting next year.

The Weak Fall a Prey to the Strong

The computer was reported to be a major subject of discussion behind the scene when Japan's surplus in trade with the United States turned into a big political issue from the end of last year to the beginning of the year. The fact that tariff cuts in computers was not mentioned in the joint communique issued on January 13 could mean that they were carried over to negotiations in autumn. The industry is dissatisfied that the computer is used for political purposes and has become an especially sensitive issue since the problem is now left to a highly political settlement, transcending economic principles and business interests. Under the circumstances, it is quite difficult to foresee the future of the Japanese computer industry.

The MITI and the Industrial Structure Council once projected the Japanese computer industry in 1985 as follows:

Domestic output will total ¥2,488,200 million, of which 16 percent will be exported. Multi-purpose computers to be delivered in 1985 will total ¥1,875,900 million (annual growth 10.3 percent). Growth of large and small computers, terminal equipment for on-line systems and mini-computers will be particularly big.

On March 15, the VLSI Technology Research Association announced that the development of Very Large Scale Integration circuits had become certain. They are considered essential for the development of a new computer series to counter IBM's new product for the 1980s, which is called the "Future System." After the Very Large Scale Integration circuit is developed by 1979, MITI apparently plans to weaken its administrative intervention in the industry and considers it inevitable to allow somewhat the principle that the weak fall a prey to the strong. Since it is difficult to establish a cooperative set-up among domestic makers at present, the computer sales business will sooner or later enter an era of competition when "the strong will win."

The decision by Toshiba to separate the sales division for large- and medium-computers will probably induce an era in which computer manufacturers will live on their specialties under market principles. Fujitsu, the nation's top computer maker, says suggestively that "the reason why we are doing our best is that we have a super giant rival, IBM."

COMPUTER MAINFRAMERS IN JAPAN

Tokyo INDUSTRIA in English Vol 8 No 5, May 78 pp 12-19

[Text]

Fujitsu Ltd.

Fujitsu has walked its own course without relying upon foreign technology, and now holds the position of the top computer producer in Japan. Sales earned by the computer business account for about 70 percent of its estimated annual sales of ¥390,000 million in fiscal 1977 which ended on March 31, 1978. Nineteen percent of computers installed in Japan by the end of March, 1976, were of Fujitsu models.

The company was established in 1935 as a telecommunications equipment manufacturer. In the early stage, it enjoyed brisk business, turning out mainly telephone sets and telephone exchanges. In 1954, it developed Japan's first electric computer, FACOM 100, based on relay. Fujitsu drew attention of concerned circles in 1961 when it introduced a transistor type computer, FACOM 222, with the largest processing capacity at that time among the domestically made computers.

The company's computer production got into gear in 1964 when it an-

nounced FACOM 230-30. This model was the first machine of FACOM Series 230, the mainstay of Fujitsu computers. As general purpose computers, more than 10 types of FACOM Series 230 machines were marketed, ranging from small to medium and large scales. Above all, FACOM 230 "8" Series computers (large- and medium-scales) are popular among users. Since their introduction in 1973, the company received orders for more than 2,060 such units.

In 1974, Fujitsu developed large-scale computers, "M" Series, jointly with Hitachi, Ltd., under the guidance of the Ministry of International Trade and Industry, to compete with IBM's 370 Series. The company has so far developed various types of "M" Series computers of which FACOM M-190 corresponds to IBM's 3033 and M-200, the latest model, exceeds them in terms of processing capacity.

The "M" Series computers feature advanced LSI technology, including 600 gates/chip logic circuits and 16,000 bit/chip main storage, and advanced architectural functions such as distributed processors and channel DAT. It was the first attempt for a computer producer to employ LSIs for its computers.

Japanese Mainframers and Their Affiliation

AIL: Amdahl International Ltd.
 CCI: Consolidated Computer Inc.
 CDC: Control Data Corp.
 FH: Facom Hitac K.K.
 HIS: Honeywell Information Systems Inc.
 IPLS: IPL Systems Inc.
 MO: Melcom Okitac K.K.
 MPI: Magnetic Peripherals Inc.
 NEC: Nippon Electric Co., Ltd.
 NPL: Nippon Peripheral Inc.

NTIS: NEC-Toshiba Information Systems Inc.
 NU: Nippon Univac Kaisha, Ltd.
 OU: Oki Univac K.K.
 SECISA: Sociedad Española de Comunicaciones e Informatica, S.A.
 SNTPC: Spain National Telephone Public Corp. (translated)
 Toshiba: Tokyo Shibaura Electric Co., Ltd.

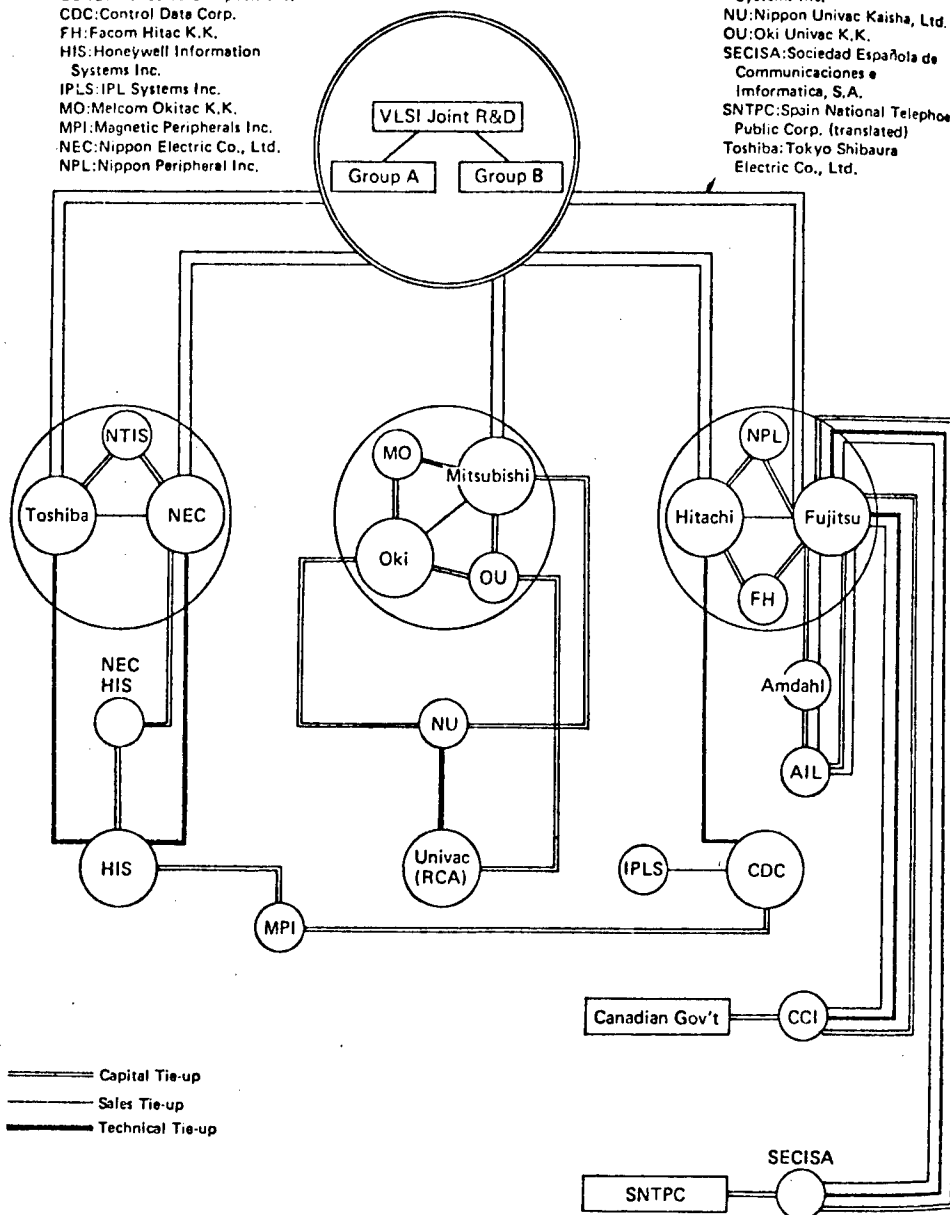

Source: The Ministry of International Trade and Industry

Another noticeable product of the company is the "V" Series office computer, which utilizes the same technology as the "M" Series. It functions as a stand-alone small-scale processor or a node computer in a larger data communications network. This system was introduced in January, 1977, and the company expects the demand will increase steadily.

Although the computer business stands out in all operations of Fujitsu, it may be too much to say that the company is a specialized computer producer. Its communications group engaged in the production and sales of telecommunications equipment is also expanding its business gradually. Its telephone switching, carrier transmission and radio communications equipment and systems are gaining high reputation of overseas customers.

For example, the first FETEX-100 electronic switching system designed for the overseas market was delivered to the Telecommunication Authority of Singapore on a semi-turn-key basis in May, 1977. The company received orders, on a full turn-key basis, for two FX800 international telephone switching systems to be installed in Uganda and Tanzania. Also in 1977, the Empresa Nacional de Telecomunicaciones of Chile granted Fujitsu an order for microwave radio communications system. It was the first order that Chile has placed with a Japanese company.

Now, the company is placing emphasis on the development of equipment and systems which combine its technologies on computers and telecommunications equipment, and its advanced LSIs will promote this line of business. Those equipment and systems include controlling systems operated by computers for traffic,

building maintenance, pollution surveillance and meteorological observation by means of satellite communications. As for overseas business, Fujitsu will intend to increase exports of computer technology, with its overseas affiliated companies as strategic bases.

Hitachi, Ltd.

Hitachi, Ltd., Japan's largest general electric and electronic equipment manufacturer expanding its business activities through high technology and sound management, completed its first computer model HIPAC-1 in 1957. The company also opened the Musashi Plant specializing in semiconductors in the suburbs of Tokyo in 1958 and put on the market the general-purpose computer HITAC 301 in 1959 to become a major Japanese computer maker.

At the instruction of the Ministry of International Trade and Industry (MITI), Hitachi, in tie-up with Fujitsu Ltd., developed the large computer M Series, followed by new large computers in place of the HITAC computer series since November, 1974. In the field of large-scale computers, it is currently turning out a variety of computers ranging from the HITAC M-180 with memory capacity of eight megabytes to the HITAC M-150 with one megabytes, and is developing units with much larger memory capacities.

As for medium and small computers, the company is marketing the HITAC 8000 Series, and its small office computers include the HITAC 20, HITAC 10 and HITAC 5. Hitachi is producing the HITAC L Series for

scatter processing, the HITAC computers for terminal processing and other computers for control use. For instance, Hitachi will newly put on the market next October the Hitachi automatic cash handling unit HITAC T-5865, capable of handling cash withdrawals and deposits at unmanned terminals. Its semiconductor department is also turning out micro-computers.

With its variety of computers, Hitachi meets almost all needs of users. It has made remarkable progress in the development of large-scale computers, gaining some share of the market so far dominated by American-made computers. Hitachi's high technique for large-scale computers drew world attention when it won orders for three huge units from the Central Meteorological Bureau in Peking in July, 1976. Their delivery has not been recognized until recently, however, due to opposition from the United States.

Hitachi began to offer its computers to users through its own rental system in 1972. Until then Hitachi's computers were offered through JECC (Japan Electronic Computer Co.) rental system. This was only possible for a large corporation enjoying a sound business performance and having plenty funds. At present, Hitachi offers 50 percent of its products through its own rental system, sells 47 percent and offers the remainder through other firms' lease or rental system.

Hitachi's sales of computers in 1976 business year ended March 31, 1977, amounted to ¥160,000 million. The sales are estimated to come to ¥190,000 million in the 1977 business year, accounting for some 15 percent of its total sales. The company ran the computer business in the red at the time when it began to offer computers

by its own rental system. Computer sales have now been growing to be a major pillar of the company's business with their earning ratio standing at a little higher than the total.

In July, 1977, Hitachi concluded a contract on sales tie-up and joint development of a huge computer system with ITEL Corp., a major U.S. computer leasing company. Hitachi accordingly shipped sample units to ITEL and is expected to export computers to the United States as well as to Europe through ITEL. At home, Hitachi has begun to place emphasis on marketing of medium and small computers. It is promoting the development of VLSIs (very large scale integration) by establishing a new firm, Computer Development Laboratories Ltd., jointly with Fujitsu and Mitsubishi Electric.

Hitachi, which is already gaining competitive power against IBM in the field of computer hardware, intends to strengthen its computer software field to meet demands in the coming age.

IBM Japan, Ltd.

IBM Japan, Ltd. is a wholly-owned subsidiary of the IBM World Trade Americas/Far East Corp. which coordinates IBM activities that extend across four continents. IBM products became a part of the Japan scene in 1925 when the first IBM machine was imported from the United States and the demand for business machines has continued to grow with the country's industrial expansion.

Japan's requirement for business machines led to the establishment of the Watson Business Machine Company as a subsidiary company in 1937. The company was capitalized at ¥500,000. Business continued to

expand until the beginning of World War II when the company had to suspend operations. But business was resumed in 1949 under the name of Japan International Business Machines Corp. with headquarters in Tokyo.

The present IBM Japan name was adopted in 1959 and IBM World Trade Corp. released technology to IBM Japan the following year. The ensuing years have seen IBM Japan grow from 66 employees to the present number of over 11,530 at the end of 1977.

IBM Corp. has been doing business in the Americas and the Far East for more than 50 years. For example, the company began operations in Canada and Brazil in 1927, the Philippines in 1920, Japan in 1925 and Mexico in 1927. Practically all of IBM's employees are nationals of the countries in which they work. This has been a long standing practice and helps to keep IBM attuned to local requirements and assures representation of national views in the decision-making process. IBM Japan has had to face very few problems with its personnel as one might expect of a foreign-owned company operating in Japan with Japanese management.

The success of IBM in Japan and other foreign countries can be attributed to the fact that the company regards itself as a member of the society and dedicates its resources to many projects for the benefit of the communities where it serves. The company has been instrumental in helping many Japanese organizations increase their productivity and conduct their operations in a modern and more efficient manner. Its customers cover a broad spectrum of Japan's financial, business, industrial and educational organizations and they can be found in such fields as agriculture, communications, public utilities, publishing, shipbuilding, storage and

transport. And hospitals, universities, research and scientific institutions, as well as government agencies, use IBM systems.

IBM Japan is involved in practically all of Japan's economy by creating a substantial amount of business for over 600 Japanese manufacturers who supply the company with parts for manufacturing a wide variety of equipment and machines used for social projects, medical research, education and environmental protection.

An IBM spokesman points out that the growth in volume of IBM business reflects the fact that information is increasingly being put to work for the benefit of people. Information technology is spreading from office to factory, from the research laboratory to the local store. And all of IBM's products in some way are involved in the handling of information-gathering, storing, processing and distributing it, and IBM Japan plans to continue to expand the capabilities of its products so that customers can use them to do more things for more people the world over.

Additional products are always being developed for future growth in IBM laboratories, and the newest technology will continue to reduce the size and cost of product components. And this will provide better performance at lower cost and, in turn, make possible many new applications that will make market expansion for IBM products.

There was a time when customers used IBM products for only a few information handling tasks such as inventory and payroll scientific study which were out of public sight. But today, information technology in some form is visible almost everywhere. It is touching people's lives directly in that it provides ease in

buying through terminals in department stores, faster checkout at supermarket counters and 24-hour banking at sidewalk teller machines.

IBM does business in 127 countries outside of the United States, and does more business in Japan than any other foreign-owned company. Through the years, it has become practically a Japanese enterprise in its operations and administration. IBM Japan's president Takeo Shiina explains that the company's business practices are in principle the same as they are in all countries where the company operates; but that certain modifications required either by law or customs are made to meet the needs of smooth operations in different countries. Such adjustments are made in Japan's operations so that management practices conform with local customs and legal requirements.

This means that some local practices are quite different from what is normal Japanese practice. For example, an applicant is screened and the final decision regarding hiring is made by the manager of the section where the applicant will be assigned after joining the company. This differs from Japanese practice in which a person is hired by the Personnel Department and placed in a certain section to work.

IBM Japan has assembled an impressive staff and its performance has been equally impressive. For example, in fiscal 1976, running concurrently with the calendar year, the company chalked up net income after taxes of ¥26,701,498,861 on gross revenue of ¥275,492,085,228, including export revenue of ¥39,378,997,789, or 14.3 percent of the total. And taxes paid amounted to ¥51,498,895,956.

Former IBM Japan President Sanae Inagaki is now Chief Executive Officer and Chairman of the Board, and former Vice President Takeo Shiina is IBM Japan's President. Its staff of nine directors include such internationally known scientists as Leone Esaki, a Nobel Prize winner in 1973, and Tadashi Ueno, former Director of the Bank of Japan, who is now Director of Financial Operations for IBM Japan.

An IBM spokesman reported that in addition to supplying users in Japan with data processing systems and related services, IBM Japan exports its products to over 65 countries. IBM Japan manufactures products at two plants. The Fujisawa Plant is located about 32 miles southwest of Tokyo and has 55,820 m² of floor space. And the Yasu Plant in Shiga Prefecture covers 45,250 m² and is devoted to manufacturing card, board and modules, and assembles IBM System/370 Models 115 and 125, and the new 3033 and 3032 processors with their new and innovative features. The Fujisawa Plant produces processing units, data storage units, printers, communications controllers, and SNA terminals. IBM Japan has data centers in eight cities in Japan, and some 40 sales locations scattered strategically throughout the nation.

Mitsubishi Electric Corp.

Mitsubishi Electric Corp. is a Mitsubishi Group member manufacturing general electric and electronic equipment and is highly reputed for its capabilities to provide technology-intensive industrial plants. While developing technique on computers for plant system controls, it turned out the medium scientific calculation computer MELCOM-1101 in 1961. Its research activities of computers soon extended to general-purpose large-scale units and various computers for control use.

From an early date Mitsubishi Electric has promoted the development of an office computer (small business computer) that can be used as a computer and a cash register. On the way of its development, the company conducted all-out surveys on users of registers at 500 places across the nation. The office computer MELCOM 80 Series made its debut in 1968. With its elaborate efforts, Mitsubishi Electric has gained control of more than 20 percent of the office computer market, the largest for a Japanese computer maker. As much as 30 percent of Japanese-made office computers sold at home carries the Mitsubishi brand.

Mitsubishi Electric, also a household electric appliance maker, began marketing *futon* (sleeping mat) drying machines in January, 1977. The company first intended to sell the machines to the areas along the Japan Sea coast having heavy snow in winter, but they are selling well also in large cities. Mitsubishi sold a total of some 700,000 units as of the end of last March. Mitsubishi's talent to sense user need properly brought the success in marketing its office computers.

Mitsubishi Electric has a business affiliation with Westinghouse Electric Corp. It started to develop ICs (integrated circuits) in 1960 on information of the world's electronic techniques supplied from the American company. At present, Mitsubishi is a major manufacturer of semiconductors, nearly 80 percent of which is sold to other companies. While widely used as parts of electronic equipment, semiconductors play important roles in the development of computers.

In the field of large and medium computers, the company has developed the COSMO Series on business tie-up with Oki Electric Industry formed at the guidance of the Ministry of International Trade and Industry (MITI). The company is currently marketing the MELCOM-COSMO Series, ranging from the large Model 900 unit having memory capacity of 4 megabytes to the medium Model 300, with combined shipment totaling 170 units at the end of last year. It is also selling the control-use computer MELCOM 350 Series whose sales are growing along with its industrial plant business.

Shipment of the office computer MELCOM 80 Series rose steadily from 850 units in 1975 to 1,550 units in 1976 and to 2,100 units in 1977. The computer series is marketed through its sales agents just as its household electric appliances. Of the sales volume, 350 units have been shipped to Europe since 1969. Full-fledged exports to the United States are expected to start soon through Melcom Business Systems Inc.; its sales outlet was set up in the United States last December. It is also turning out the minicomputer MELCOM 70 Series

to be used for scientific calculations, processing control, medical and other wide purposes.

The company is also developing peripheral and terminal equipment. Mitsubishi's display equipment and *kanji* (Chinese character) processing equipment are gaining broader demand. It is also accepting for its units line-printers and other peripheral and terminal equipment made by Oki Electric.

Mitsubishi is widening the floor space of the Computer Works at Kamakura, southwest of Tokyo, by 6,000 square meters. The company's computer department chalked up sales of some ¥40,000 million in 1977 business year and plans to boost the annual sales to ¥100,000 million in five years. Mitsubishi intends to make the computer department, which is now barely making ends, a stable and profitable business section by boosting business scale.

Under the MITI instruction, Mitsubishi is developing VLSIs (very large scale integration) through Computer Development Laboratories Ltd., a joint firm with Fujitsu and Hitachi. Enjoying sales increases in office computers, Mitsubishi concentrates its efforts on the development of system controls for industrial purposes to reorganize its structure to catch up with the global development of computer technology.

Nippon Electric Co., Ltd.

Nippon Electric Co., Ltd. (NEC) is a member of the Sumitomo Group, one of the major industrial concerns in Japan, and has long been well known at home and abroad as a leading manufacturer of telecommunications

equipment. More than 45 percent of the turnover accrues from the sales of products in this business line.

But NEC also has a history of computer production which it can boast of. The company first started research of digital computers in 1954 and completed Japan's first all-transistor-type computer, NEAC-2201, and a Parametron type computer in 1958. These were medium-size computers at that time. Next year, the company completed the NEAC-2203 computer (medium-size), the first success in Japan in computer production on a commercial basis.

In 1962, the company introduced the technology of Honeywell Inc. of the United States and produced NEAC Series 2200 computers in 1965. The machines of this series later became the main products of the company. They were the first domestically-produced "one-machine" computers (which could convert programs, even if the machines' processing capacity became large).

The recent product worthy of special mention is the ACOS Series 77 completed in May, 1974. The computer, jointly developed by NEC and Tokyo Shibaura Electric (Toshiba) under a technical tie-up, was a rival of the IBM 370. Ever since, NEC's main products have been ACOS Series computers, which now include the System 200 (small-size), Systems 300 and 400 (medium size), System 500 (medium/large size), Systems 600 and 700 (large size) and Systems 800 and 900 (ultra-large size). The System 900 is a rival of the IBM 3033.

What cannot be overlooked in NEC's computer division are the so-called office computers (small business machines). They are simple machines with NEC's "ready-made" programs, which can be handled easily by ordi-

nary people without the knowledge of computers. For efficient operation, users have only to add their own programs to the ready-made ones. NEC also played the role of a pioneer in this field of business. The NEAC System 100 marketed in 1973 has been popular among users and the company booked orders for 3,205 machines by the end of September, 1977, shipping 3,805 of them and exporting 90. NEC is in business tie-up with Ricoh Co., Ltd. on office computers.

While Honeywell Inc.'s technological assistance has greatly contributed to the development of computers by NEC, NEC can now produce computers with its own technology alone. It will concentrate its efforts on how to increase sales, while promoting technological development. This is because the larger the sales of computers, the more become profits.

Although the Japanese computer industry has been under direct or indirect government protection, it cannot expect much assistance from now on. Each producer has to make its own efforts for expanding sales.

NEC's sales strategy will call for winning new clients in Japan. The company will also make efforts to improve basic software and minimize changes in users' programs. NEC considers that latent demand for computers is still large.

Meanwhile, further efforts will also be made for increasing exports. Last year NEC established NEC Computers Singapore Pte., Ltd. in Singapore, and NEC Information Systems, Inc. in the United States. For the time being, the former will serve as the base of computer sales to Singapore, Indonesia, Malaysia and Thailand, and the latter

will sell office computers and memories in North America.

NEC executives have this to say about exports: "We should not export surplus products originally made for the domestic market. We have designed products fit for use in importing countries (not meaning changing the shapes of products) and have given similar consideration to software and peripheral equipment."

The company's turnover for the business year ended in March, 1978, is estimated at about ¥540,000 million, of which the sales of computers (including office computers) are believed to have reached about ¥140,000 million.

Nippon Univac Kaisha, Ltd.

Nippon Univac Kaisha, Ltd. was established in 1958 and is one of the leading industrial enterprises marketing a wide variety of computers and related materials, and offering services to Japanese industrial and institutional organizations. The company has some 4,330 employees and capital of ¥3,684,564,000. Its net profits for fiscal 1976 were ¥1,236,000,000, and annual revenue for the same period reached ¥70,797,000,000. Jiro Fukunaga is the company's president. He is former Executive Vice President of Mitsui & Co., Ltd. and Chairman of Europe Mitsui.

It is often said that the history of Univac is the history of electronic computers throughout the world and this is true in Japan. It was in 1923 that the Powers Punched Card Systems were introduced by Mitsui & Co. to the Ministry of Railways, the Customs Department and the Cabinet Statistics Bureau as the first data processing systems in Japan. And by the beginning of World War II, more than 600 sets of PCSs had been installed.

After the war, the Yoshizawa Accounting Machines Co. became the agent for Univac and in 1955 the company installed UNIVAC 120s at the Tokyo Stock Exchange, Nomura Securities and other Japanese enterprises. Thus, the UNIVAC 120 became the first computer operation in Japan and one of the original UNIVAC 120s can be seen as one of the permanent exhibits at the National Science Museum in Tokyo to commemorate the beginning of computerization in Japan.

In 1958, Nippon Remington Univac Kaisha, Ltd. was established as a joint

venture with Mitsui & Co. and Sperry Rand Corp. This was the predecessor of Nippon Univac Kaisha, Ltd., and Oki Electric Industry Co. joined the venture in 1963.

Nippon Univac has among its customers many of the best known industries and organizations in Japan and last year installed 37 sets of imported super-large size computers of UNIVAC 1100 Series, three sets of imported large computers of UNIVAC 400 Series, and 106 sets of domestic computers, the OUK Series 90 and OUK 9000 Series.

Shortly before the partnership venture of Remington, Mitsui and Oki, Nippon Remington Univac (NRU) imported four sets of UFS's and about 50 USSC's and these computers, along with the UNIVAC 120, in which more than 30 were already operating, generated strong ardor for computerization of business areas in Japan. The introduction of the UNIVAC 1004 in 1962, followed by the 1050 in 1964 and 1040 in 1965, was the beginning of NRU's strong penetration of the computer market, and the 1004 became the best selling computer in the history of NRU. Securities firms, government agencies and public utilities firms became users of the 1004.

Preparations were completed in 1963 to produce domestic electronic computers under the brand name of OUK at Oki Univac Kaisha, Ltd., another joint venture of Sperry Rand and Oki Electric. The joint venture firm began to produce the 9200, 9300 and 9400 and peripherals. And in 1971, the OUK 9700 Series computers were added and provided a wider range

of computer power at lower cost. The Series 90 computer system was added in 1974.

Nippon Univac has played a major role in the advancement of the use of computers in Japan. It was in 1964 that the first successful on-line, real-time trial in Japan was carried out with the UNIVAC 490 at the Japanese National Railways, and in 1967 Fuji Bank inaugurated its on-line banking system by using UNIVAC 418s. This opened up a new era of on-line operations in the banking field; and major city banks quickly followed the lead set by Fuji Bank and established their own on-line systems with UNIVAC computers.

And in 1967, Ishikawajima-Harima Heavy Industries started the first successful Time Sharing Operations. This not only showed Univac's superior technology, but also led to the rapid computerization of industry. In 1970, the company introduced to the market several new computer systems which gave them leadership in real-time and TSS operations. In 1970 the UNIVAC 1110 Series, along with low priced UNIVAC 1106 was introduced. NUK now has two major product lines, the UNIVAC 1100 Series and the OUK Series 90. The UNIVAC 1100 Series consists of 1100/10, 20 and 40, and its most recent entry on the market is the 1100/80. There are four sub-models in OUK Series 90. They are the 90-300, 90-600, 90-700 and the most powerful 90-800.

In 1977, the company opened its new headquarters building in Tokyo with offices and 229,000 square feet of floor space and a large computer center. The headquarters also houses an information center and other facilities for user services. The UNIVAC Education Center has also moved to the new Toho Life Insurance

Building from NUK Headquarters and has a total floor space of 2,475 square meters which is about twice as much space as the center had before, computers are installed there for training purposes and are connected on-line to the UNIVAC 1100 Series computer in the Data Center at NUK Headquarters. And with a deluxe facility at Izu overlooking the Pacific Ocean, management seminars are held at the Izu Executive Center. The Center is utilized for training top executives of NUK users and prospects in the use of operating computers, and about 1,000 attend these seminars each year.

It was pointed out that new software must be developed in order to create more demand for computers and equipment, and that computer users must participate in this development of demands by creating wider applications. Both customers and suppliers must develop new computer application and computer users must consider software, hardware and personnel in order to make better use of electronic computers. Nippon Univac feels that with a firm base the company will be able to meet the increased competition in the computer field, and continue to offer services to its users.

Tokyo Shibaura Electric Co., Ltd.

On February 27, 1978, Tokyo Shibaura Electric (Toshiba) and Nippon Electric Co. (NEC) announced their basic agreement on strengthening their business tie-up regarding the large and medium-size computers of the ACOS Series which they had developed jointly. Under the agreement, Toshiba's sales division for the ACOS Series is to be transferred to the NEC-Toshiba Information Systems Inc. (NTIS), and NEC will also dispatch some personnel to the joint company. Toshiba and NEC are making arrangements for implementing the plan early in April.

The two companies developed the ACOS Series under a business tie-up agreement in November, 1971, and jointly established NTIS in March, 1974, for cooperation and adjustment of their business related to large and medium-size computers and for the development of VLSI. The ACOS Series on the market covers computers of all sizes ranging from the large System 900 to the small System 200. In addition, Toshiba produces process computers, TOSBAC 7000 Series; minicomputers, TOSBAC 40 Series; small business computers (office computers), TOSBAC System 15, 35 and 55; desk-top and pocket-type calculators and microcomputers to meet any need of customers.

Minicomputers, small business computers and calculators, in particular, are selling well, bringing in large profits.

The total number of office computers shipped so far has exceeded 10,000. About 250 sets of ACOS Series have been sold, including those yet to be delivered. And recently, one set of the ACOS 600 was exported to

the Construction Public Corp. of Iraq. However, the business on large and medium-size computers is still in the red. The above-mentioned step is being taken to strengthen business in this field. Although NEC will retain its ACOS sales division, it will send required personnel to NTIS. This means that Toshiba has made a step closer to NEC in the field of computers for general purposes. Toshiba continues to produce and develop ACOS Series computers, but the division in charge of ACOS Series will amalgamate with the one in charge of office computers to form a strengthened computer division.

Toshiba is one of the Japanese companies which started the study of computers at an early date. Since the completion of the computer, TAC, in 1954 jointly with Tokyo University, it has developed various sorts of computers carrying the TOSBAC brand to meet the varied needs of customers. Toshiba, one of Japan's leading manufacturers of electric and electronic equipment, is in business tie-up with General Electric (GE) of the United States. Toshiba has domestically produced computers of the GE 400 Series and marketed the TOSBAC 5400. After GE's computer division was transferred to Honeywell Inc., Toshiba concluded a technical tie-up arrangement with Honeywell Information Systems. Toshiba also produces semiconductors and ICs. The company has high-standard computer technology.

Toshiba's sales of computers total about ¥60,000 million a year, which do not account for a big portion of the company's annual turnover of about ¥1,000,000 million. But the computer business is an important one for this

general electric and electronic equipment manufacturer.

Toshiba is featured by its development of systems. A good example is the traffic control system delivered to Tokyo's Metropolitan Expressway Public Corp. Using the control computer, TOSBAC-700 Model 25, and a graphic panel of 3 m by 10 m, this large-scale system controls traffic on about 100 km of highways in Metropolitan Tokyo.

At the same time, Toshiba is the top maker of ME (medical electronics) equipment. Since the present factory on the site of 65,000 m² has become too small for the production of such equipment, the company is constructing a specialized ME plant on the site of 165,000 m² in Tochigi Prefecture, north of Tokyo. With the systematization of ME equipment going on, the company has delivered an emergency medical treatment information system to the Medical Center of Ibaraki Prefecture, north of Tokyo. The trial manufacture of computed tomography system for medical use has just been completed, and the products are to be put on the market in summer this year. Toshiba will continue to grow by meeting the needs of the new age with its computers.

CSO: 5500

VLSI RESEARCH AND DEVELOPMENT MOVES AHEAD

Tokyo INDUSTRIA in English Vol. 8 No. 5, May 78 pp. 22-23

[Text]

Cooperative Laboratories of the VLSI Technology Research Association, engaged in technological development of VLSI (Very Large Scale Integration circuits), announced in March, 1978, the development of an electron beam writing system in which microscopic patterns needed for VLSI production can be drawn with high precision and speed. In completing the system, Cooperative Laboratories set specifications; Tokyo Shibaura Electric (Toshiba) designed and manufactured the equipment; and the Laboratories added functions and summarized the system.

In VLSI production, it is necessary to draw far more complicated circuits on small semi-conductor tips. The line width of the pattern drawn on the LSI tip was approximately 10 microns at the smallest in the past, and an optical pattern generator was in use. But the line width of LSI is being reduced to a scale ranging from two to four microns. The light beam, therefore, requires quite a long time for pattern drawing, and the accuracy of work is not high. That is why the development of electron beam writing systems is popular in many countries today.

The system newly developed by Cooperative Laboratories adopts a Raster scan system, being a high performance device whose electron beam current is more than ten times that of the conventional type, and is capable of drawing speedily patterns whose minimum line width is one micron with errors of about 0.1 micron.

For high-speed processing of pattern data, the system employs the magnetic disc of 160 M bytes and TOSBAC 40D, a minicomputer. The writing speed has also been raised by incorporating a data compression system. It is capable of drawing a pattern having minimum line width of two microns on a mask substrate of 125 mm² in 50 minutes. It is also incorporated with new technological developments such as a unique temperature control system.

Cooperative Laboratories developed an electron beam writing system of variable beam size in the spring of last year. By combining this with the latest device, the Laboratories will pursue practical use of microscopic processing technology by use of electron beam.

The VLSI Technology Research Association was established in March,

1976, by seven corporations of the Japanese computer industry to develop VLSI technology, which is the key to the future development of computer systems. Association members are Fujitsu Ltd., Hitachi, Ltd., Mitsubishi Electric Corp., Computer Development Laboratories Ltd. (CDL; a joint venture of the above-mentioned three corporations), Nippon Electric Co., Ltd., Tokyo Shibaura Electric Co., Ltd. and NEC-Toshiba Information Systems Inc. (NTIS; a joint venture of the above-mentioned last two corporations).

Research is carried out at three laboratories; Cooperative Laboratories of the Association is responsible for fundamental technology, and laboratories of CDL and NTIS for application technology. The total budget for re-

search and development is approximately ¥70,000 million. The Ministry of International Trade and Industry is to award the Association a subsidy totaling about ¥30,000 million during the period between fiscal 1976 and 1979. Electro-Technical Laboratory of the Agency of Industrial Science and Technology and Nippon Telegraph and Telephone Public Corp. are assisting Cooperative Laboratories technologically.

In addition to the above-mentioned electron beam systems, the Cooperative Laboratories has also developed a multiple wall self-alignment technique enabling the production of finer elements than the conventional method. Thus the Laboratories is advancing step by step toward the development of VLSI.

CSO: 5500

BULGARIA

MINISTRY OF COMMUNICATIONS REVIEWS 1977 ACTIVITIES

Sofia IMPULS in Bulgarian 28 Mar 78 p 1

[Report on ministry collegium meeting]

[Text] A joint meeting between the Ministry of Communications Collegium and the Bureau of the Central Committee of the communications workers trade union, chaired by first deputy minister engineer Stoyan Markov, was held on 24 March. The annual report and balance sheet of the ministry covering its 1977 economic activities were considered and adopted. The meeting was attended by representatives of the BCP Central Committee, the Council of Ministers, and all functional ministries and departments observing the ministry's activities.

It was reported that all economic units fulfilled their state and counter-plan for the volume of output. The good economic results are due, above all, to the active participation of all collectives in the implementation of the plan, developing socialist competition on a higher level. The measures for the modernization, reconstruction, and development of the material and technical base of communications were the factual base for the implementation of the plan. Thus, in the course of the year another 1,933 automated interurban telephone lines were installed. The number of automated telephone exchanges was increased by 115 while the capacity of the exchanges rose by 104,710 sets. This created conditions for the installation of 93,165 telephone sets to meet the needs of the population and the national economy. The number of telex units was increased by 160. These successes contributed to the fulfillment and overfulfillment of all economic quality indicators such as profits, profitability, production cost, net output, and others. Along with positive results, a number of weaknesses were allowed by the collectives pertaining, above all, to the quality of population and state enterprise services. The attention was directed to the still high number of breakdowns and their duration, delays in the replacement of telephones which, together with breakdowns in interurban communications, caused billion of leva's worth of losses. The collegium and the bureau resolved to accept the ministry's report and balance sheet for 1977 and to continue the work on the overall assessment of the functioning of the communications system and of its contribution to the implementation of the national economic tasks. Such an assessment should be made by all enterprises within the communications system.

The report stresses the great personnel turnover which would require of the okrug communications administrations to make a detailed study of the reasons with a view to reducing it to the normed limits.

The collegium also considered information on the implementation of the comprehensive program for the development of telephone and telegraph communications in the Seventh Five-Year Plan. A basic feature of the information was the question of improving the quality of telephone services with the gradual conversion to and installation of new switching equipment.

Also considered was the matter of condensation equipment and the possibility to increase the handling capacity of existing exchanges using symmetric cables. This measure will yield major economic results, bearing in mind the shortage of cables and the urgent need for the more effective utilization of existing cable circuits through the use of condensing equipment. The problem of relations with the Ministry of Electronics and Electrical Engineering, which is delaying the procurement of the necessary equipment of the development and modernization of the material and technical base of communications was considered as well.

A no less interesting problem was that of the collective labor contracts and their implementation in 1977. It was noted that along with good results enterprises and branches still exist which pay little attention to collective labor contracts.

The problems jointly considered by the ministry collegium and the bureau of the trade union's central committee and the decisions made will make possible to improve production-economic activities in the field of communications and, particularly, the quality of services by improving the maintenance of the existing equipment and the installation of new one.

5003

CSO: 5500

COMMUNICATION TECHNICIANS COMPLAIN OF LOW QUALITY MATERIALS

Sofia IMPULS in Bulgarian 28 Mar 78 pp 1, 3

[Article by Gerasim Balabanski, group technical manager in Blagoevgrad:
"The Origin of Mistakes"]

[Text] High quality goods may not be made of unsuitable materials.

Frequently construction workers have been blamed for delays in the completion of the projects, poor quality of the work, inconsistency, higher costs, and others. Unfortunately, in many cases such charges are legitimate. Facts are facts, and no one could deny them. I do not wish to justify myself or my comrades for our errors. We try to avoid them and not to repeat them and we are largely successful.

However, we find it difficult to surmount obstructions created by institutes and services whose entire purpose is to help us. Their errors are such that they inevitably effect both our deadlines and quality of work. This implies to the laying of intrarayon cables, urban cable grids, and telephone and telegraph and radio grids. Weaknesses in all three types of work are almost identical in the preparatory period: The initial planning data are compiled formally, hastily, without the necessary study by the people who issue the assignment. Above all, designs are rough, without the necessary details for the installation of the cables in premises, and without confirmed prices. Frequently we find in the blueprints unerased names of re-drafted parts. The prices do not correspond to those on which the plan is based. For this reason in the case of five projects in Blagoevgrad Okrug the Bulgarian National Bank did not recognize a single one of the prices indicated in the draft estimates.

Frequently the project is designed in two or three days and the tracks are measured from the car rather than with a tape. The only exception is the work of Comrade Leteyski. This, however, can not amend the faceless flow of draft estimates made by Isproekt and the okrug administrations.

Occasionally it takes years to complete a given project and even more time is lost as a result of the extended investment process. We would be sent on a project which stipulates the existence of a highway. Arriving on the spot, we see that the highway is located in an entirely different area. The blueprint may indicate an empty lot yet we see huge residential blocks. Conversely, we would see no markers wherever they should be.

Another disparity is the lack of coordination between allocated funds and construction deadlines. Thus, in a project 20 kilometers long to be completed, for example, in 12 months, funds are provided for five years! In such a case there is no point to take to such projects equipment or provide housing facilities for the men.

Our turn comes after a cost estimate document has covered the long way from designing to funding.

Yet, the basic production unit--the technical manager--would not be provided with a list of the equipment which should be made available to a group in charge of completing a project worth 500,000 leva or, in the case of a group such as mine, costing over 2 million leva. This would require a tractor with a ditch digging machine, a tractor with a bucket for digging the canal network, a bus with up to 25 seats, a truck, and two installation workers who would immediately tie up loose cables. Yet, what is the situation? The level of mechanization is low but even if mechanization facilities are provided they can not be used fully.

Before undertaking the construction, the project as a whole must be supplied with at least 70 percent of the necessary materials. Last year we worked on eight projects for which we waited for cables which we never received.

What about the great variety of installation materials! There are no end boxes, there is no installation tape or bearing metal and no substitutes. The use of substandard gasoline led to the breakdown of 50 gasoline lanterns.

How did my group, for example, acquire 6.5 meter high reinforced concrete poles for the Belmeken-Sestrimo Power System? One side of the allocated 800 pieces was stripped, which made us lose 13,000 leva. The assemblymen had to use a solder in which there was more lead than tin as a result of which it kept crumbling. Where were suppliers and purchasers? What could we say about the different width of the installation tapes? The worker must cut the tapes to size and lose time. Instead of performing lesser operations at the site, now we are receiving from the enterprise in Borima lead sleeves requiring two seams instead of one.

The quality of the cables is below criticism. For the Gotse Delchev Urban Cable Grid, with a single technical manager, 98 EF boxes had to be redone due to the low level insulation of the bakelite. The cable ends can not withstand the humidity. This not only worsens the quality but entails unfair fines even though the workers in this case are innocent. No system is presentable if it has to be assembled and disassembled three times running.

These are matters which the management of our construction organization should deal with and resolve.

I suggest that the lineman who installs a box should leave in it his calling card. This way, 50 years or 5 days later, if necessary, we would see who and what organization are responsible for the assembly. Why not issue guarantees for each project? This would upgrade the role and responsibility of the technical managers and technological discipline. All construction workers well know that technological discipline is being violated. We decided to observe the necessary depth of the trenches. For the past seven to eight years, however, no one has mentioned the depth as we deliver a project.

Some organs are interested only in the implementation of the volume plan. In their case no one keeps track of the way we work, the working conditions, and the rating of the acceptance commission. Yet, form No 16 represents a rating of several years of work of a given collective. The telegram of thanks which the management of the construction organization sent to technical manager Levunliev and his group for the Samokov-Borovets Project played a positive role. However, this was the only case of its kind in 10 years! Why not make it a practice for the trade union management?

It is of interest that in the past five years no single manager from Isstroy and, presently, Telekomplekt has visited my area or even gone to the okrug people's council to meet with local city and okrug managers. This would have been useful and would have consolidated our authority, for the solution of many problems involving the living conditions of the group depends mostly on the local management.

The fact that no one gives a thought about the prestige of our people is confirmed by yet another example: We received a letter summoning our people to attend a training course. This was good. They showed up. However, no other personnel showed up and the course did not take place . . . yet, new developments in communications construction are numerous and should be studied continually. Therefore, both the training and retraining of cadres is unsuitable.

I am writing about such things with a feeling of pain and dissatisfaction. We are asked to insure prompt and faultless construction. This is proper. However, let us not forget that the quality of a project and its completion deadline do not depend exclusively on the construction workers.

5003
CSO: 5500

BULGARIA

INEFFICIENT MANAGEMENT OF COMMUNICATIONS EQUIPMENT CRITICIZED

Sofia IMPULS in Bulgarian 28 Mar 78 p 3

[Article by Yordan Bezhev: "Once Again on Unused Opportunities; Careless Work"]

[Text] In the past two five-year plans the material and technical base in communications developed at a faster pace. Compared with 1970, in 1977 productive capital in communications was 2.6 times higher. As a result of the modernization the handling capacity of automatic telephone exchanges rose over 2.5 times. The capacity of settlement cable grids also rose over 100 percent.

Modernization was extensively applied to the development of telegraph communications as well. The capacity of automated telegraph centers rose 2.5 times between 1970 and 1977. This enabled 90 percent of the post-telegraph and telephone exchanges within the automated gentex network to exchange telegrams directly.

At the end of 1977 95 percent of the country's territory was covered by the first medium wave radio channel, while the second channel reached 87 percent of the territory. The three ultra shortwave radio programs are received by 80 percent of the country's population. 81 percent of the population enjoys quality reception on television channel 1 while 60 percent have quality reception on channel 2.

Along with these positive results in the development and modernization of the technical base of communications, we should acknowledge that it is not being used efficiently. A study of overall data for the communications sector has revealed that 16.2 percent of the capacity of settlement telephone exchanges remain unused, even though 32 percent of the pairs in telephone circuits are free. Meanwhile, the need for telephone sets remains high.

A similar situation prevails in the rate utilization of interurban telephone communications. Their condensation coefficient from 7 am to 10 pm does not exceed 24.2 percent. Compared with international practice this is a very low figure.

The automated telegraph office capacities are also used inefficiently. At the end of 1977 31.4 percent of the stations' capacity were unused. Is everything necessary being done for the opening of more telex units?

Some management cadres and specialists of the communications subunits should amend their style and method of work and think and work in a new way, for possibilities for upgrading the results of economic activities in communications and drastic improvements in the quality and standards of services largely depend on the subjective factor. It is imperative to increase the exactingness toward all specialists and workers and to upgrade the feeling of responsibility for the successful implementation of assigned tasks.

Some chief specialists of the okrug administrations must abandon their formalism and inertia in their work. The struggle for high effectiveness and high quality must become their daily concern. Bottlenecks in the utilization of the capacities of settlement telephone exchanges and cable networks, interurban telephone communications, and telegraph centers must be found through systematic studies of the condition in the field of communications. Bottlenecks in the organization of the work must be found and breakdowns of equipment and circuits must be eliminated on time. Weaknesses in communications traffic and service standards must be removed. This is only one aspect of the matter.

Effective measures must be taken to improve the work and insure the fuller use of discovered possibilities for increasing revenue with minimal labor, material, and financial outlays per service unit. This will convert the chief specialists into effective associates of the okrug's management in the struggle for high effectiveness of economic activities and high qualities of services.

Departmental financial control audits have revealed that income is lost as a result of wrong billing for various services. In 1977 such losses totalled almost 600,000 leva. Unpleasant omissions were noticed in Vidin. An additional amount of 110,000 leva was collected as a result of wrong billing for services. Similar weaknesses were noted in Kurdzhali, Blagoevgrad, Kostenets, and others.

In Vidin improper control led to the charging of wrong fees for the maintenance of 15 office telephone exchanges. The stipulation that the fee must be based on the installed capacity of office telephone exchanges was violated. Also wrongly billed were the telephones of 59 enterprises and establishments outside settlement limits, even though the ministry has repeatedly issued instructions on this matter. Such weaknesses were allowed in Razlog as well--the telephones of four enterprises were billed erroneously.

These are neither recorded nor collected for 124 radio telephones in Kurdzhali, and for 5 at the RSS [expansion unknown] in Kostenets; no fees are collected in Blagoevgrad for a radio system with 74 speakers.

No regular and full records are kept on temporary radio broadcasting installations in Vidin, the Kostenets RSS, and elsewhere. This has been the reason for improper billing and loss of revenue. In Kostenets alone fees for six temporary radio broadcasting installations were not levied.

By the fault of Ginka Georgieva, accountant at the Vidin-Center Post Telegraph and Telephone station the proper fees for 33 television sets and 18 radio sets were not collected even though the commercial organization sent a copy of the sale and purchase receipt.

A number of examples could be cited of erroneous billing for services. The conclusion, nevertheless, is one: The weaknesses are caused by the respective officials and as a result of insufficient control on the part of the proper services of the okrug communications administrations.

All this indicates that the successful implementation of the party's decisions on high effectiveness and quality of services largely depends on the subjective factor. The main thing now is to involve every worker and specialist in the field of communications in the implementation of the 1978 counterplan through out work, creative attitude toward the solution of daily problems, rapid elimination of work weaknesses, and extensive utilization of leading experience of innovators and labor champions.

This will be our greatest contribution to the building of a developed socialist society.

5003
CSO: 5500

HUNGARY

OLD STUDIOS, TRANSMITTERS TRANSFERRED, NEW ONES PLANNED

Budapest NEPSZAVA in Hungarian 29 Apr 78 p 4

[Article by T. M.: "The Lakihegy Transmitter; It Belonged to Kossuth, It Belongs to Petofi; A studio in a Moving Van; Sound War: Only Resting, not Farewell; New Transmitters; Telephone News and Stereo"]

[Text] There is a mountain in Hungary which is really a plain but everyone knows its name--Lakihegy. When the site was selected--just 50 years ago--the postal authorities were trying to pick a place to which it would be easy to "transport" the electric power and where mountains and hills would not interfere with transmission.

The truth is that Lakihegy was not the cradle of Hungarian radio. The first step was the telephone news service and then when radio transmission began the studio was at number 22 Rakoczi ut. The program was transmitted from Csepel with a power hardly exceeding that of 6 lightbulbs. Broadcasting has an adventurous history for the first studio was in a moving van but they also held concerts in the Zoological Garden.

Building a "real" transmitter became ever more urgent in the second half of the 1920s. The decision was made on the basis of an international competition and Telefunken got the commission. The transmitter was placed into operation in ceremonies held on 29 April 1928. At that time they built a cigar shaped tower 150 meters high. Lakihegy has been reborn and rejuvenated many times since. Most recently, about a decade ago, they set up two transmitters of 150 kilowatts each so that Kossuth should be stronger. But its voice was increasingly lost in the international ether war; in the 1930s transmissions could be received 6,000 to 7,000 kilometers from Budapest. After the war, in 1948, the medium wave frequencies were divided up among the various countries at Copenhagen. The operation of 100 to 120 transmitters was authorized. In contrast to this, in the second half of the 1960s, more than 3,000 transmitters were broadcasting in the medium wave with ever greater power, drowning one another out. Frequently, the voice of Kossuth could not be heard 100 kilometers from the capital while transmitters from the Middle East could be heard. Sunspot activity plays a role in this also.

So it was decided to build the Solt transmitter. The transmitter, which was put into operation one and a half years ago and which was completed before the time limit with a significant saving in costs, has proven outstanding in practice. The antenna tower, higher than a hundred story building, reaches not only the larger part of the country, as is proven by measurements, but letters are even received from London and Leningrad reporting that Kossuth comes in outstandingly. Because of the shaded areas it cannot achieve greater than 80 percent efficiency within the country. The final solution can only be a development of the ultra short wave network and the first phase of this program will be completed by 1980.

Is Lakihegy going into retirement? Not at all. For the time being the two 150 kilowatt transmitters are resting but the 20 and 135 kilowatt transmitters are broadcasting the Petofi programs. The Petofi broadcasts can still be heard well only in 45 percent of the country. Thus, Lakihegy will receive an important role in the future in broadcasting the Petofi program. The two 150 kilowatt transmitters will be broadcasting the Petofi programs. But this is not a complete solution and so they are planning to place into operation a 1000 and a 500 kilowatt transmitter of Soviet manufacture in Szolnok and Balatonszabadi respectively. The number of radio subscribers exceeds 2.5 million but there are more than 6 million pocket, portable and table radios in the country. The development of the ultra short wave and stereo programs will play an ever greater role in addition to the medium wave. This is the radio of tomorrow because ultra short wave and especially stereo guarantee perfect quality and reception. A person listening to stereo feels that he was sitting in the middle of the orchestra. Trade turnover also shows that even today most people are buying ultra short wave and stereo sets. Overage in the history of radio has ended but in the shadow of television it has not only a past but also a more certain and louder future than ever before.

8984
CSO: 5500

NEW, EXPANDED TELEPHONE DIRECTORY TO BE PUBLISHED

Budapest NEPSZABADSAG in Hungarian 7 May 78 p 16

[Article by Gyula Fejer: "Telephone Subscribers, Attention: The New Telephone Book is Being Prepared"]

[Text] There is no survey to prove it but we can still believe the rumor that the most often read book is the telephone book. But it also causes much anger because it contains regiments of invalid data. The private Budapest telephone book now in circulation was prepared in 1971 and the press had been working on it for a year so it is no wonder that it could not be called perfect even when it appeared. Since then, the thick volume containing 280,000 items became obsolete at a swift pace and today at most, 80,000 items are correct.

Many Numbers Have Been Changed

"The reason for this," Mihaly Torok, chief of the Telephone Information and Directory Editing Office, explained "is that every day an estimated 150 private and 50 public telephone book items change in the capital, partly because many change residences or get new degrees or professions. A greater role is played by the swift development of technology; the postal authorities have placed into operation the Inner City Telephone Center and have modernized the old ones so that many telephone numbers have changed. We have installed tens of thousands of new sets in past years and these do not appear in the directory."

Why is publication of a new telephone book being delayed if the existing one cannot be used? The question is just but there is a satisfactory answer to it. It is simply because even this year new sets are being installed at many places in the city and for technological reasons many numbers will soon be changed. The new directory of private subscribers now being prepared will contain these also. If the book had been published last year it would be crawling with errors. In accordance with the guiding principles of the postal directorate number changes intended to aid service were completed by 30 April this year so that the editors of the telephone book could finally begin their last adjustments. The experts are being so

careful of quality that they are including in the list the assigned numbers of about 15,000 telephone subscribers who will be changing numbers.

There is much activity in the office of the directory editor; the work which has lasted a year and a half is coming to an end. They are signing the work for publication. Their task is not an easy one for the telephone book being prepared contains 30 million letters and this had to be read through four times to avoid even chance errors. The members of the technical staff are retouching, photographing, enlarging, measuring, and inspecting the saturation of letters. The editors are now dealing only with changes still arriving and their dark-ringed eyes show that the feat is not an easy one. The letter A was closed on 2 May, the letter B on 3 May, the letters C and CS one day later, and the day before yesterday the list began with the letter D.

So what will the new telephone book be like?

"Our maximal goal," the leading editor said, "is to provide the public with a telephone book which can be used more easily than the earlier ones. The book contains an alphabet for easier use; we have simplified the order of letters because up to now in existing books we have listed separately those names which included occupations; we now disregard this. Thus if someone is looking for a name he does not have to go through one list after another in vain. In addition, we have emphasized for the sake of simplicity more than 600 names which have the same sound but which are written differently. For example, the surname Ag can be written correctly as Agh or Agg and Kovacs, which is certainly not a rare name, can be written as Kovats or even Kovach. Those interested will find these versions in parenthesis. Substantially larger letters than customary will be used to indicate the beginning and concluding names in the upper corners of each page."

1,600 Pages, 350,000 Items

Everything for the public and the common cause. It was in this spirit that the editors of the new private telephone book worked to the end. It was for this purpose that they put an end to the jungle of occupations because--humorous though it may be--we can find in the present book a good number of names which include a virtual autobiography. These microsociographies are an indication of the excessive increase in social ranks. But it is not the primary purpose of the telephone book to be a collection of ranks. This would only increase the cost of preparing and publishing it. The telephone book which appeared in 1971 had 976 pages and 280,000 items. The new book will have 1,600 pages and 350,000 items. Those who asked that their occupation be indicated could indicate only one. But the editors did make exceptions in this especially in regard to services.

A Few Minutes for Information

Although it is not a literary work it is worth devoting a few minutes to the chapter titled "Information" which can be found at the beginning of the book for a reader perusing it can learn everything worth knowing about all areas of the postal service. He can learn when the post offices are open and how to make telephone calls at home and abroad. We can find in this chapter a detailed drawing to speed up the repair of faulty telephone sets, giving the name of the parts and the way in which various problems appear. No set should break down but this is only a dream. Never mind, only page through the book to the appropriate place and the diagnosis can be worked out. When O3 knows this he can send out a repairman.

There is no limit to the useful information. We can find sample addresses, time zone maps, telephone bill information and where to turn in postal matters. The telephone book contains zip codes for the towns throughout the country, a directory of Budapest streets which have been repaired, a list of box renters and a precise copy of a sample letter. This chapter, containing 64 pages, provides orientation in more than postal matters. It reports on district medical offices, pharmacies, councils, police stations and shopping services. The 200-page professional guide aids everyday orientation and it is especially interesting that for the first time it contains the name and address of artisans who do not have telephones.

It Will Appear in the Fall

The editors will complete their work in a few days and the compiled pages are going on film to the Athenaeum Press. The cover has already been prepared, designed by the artist with a musical name, Crescencia Zelenak.

"The presses will start in a few days," Antal Kiraly production director for the Athenaeum Press, said. "The book will be in two volumes of 800 pages each on thin but long lasting Finnish paper. No telephone book has ever appeared in Hungary with such a swift press time; we will finish 160,000 copies in five months. The chief credit goes to the post office, a few years ago they purchased abroad film transfer equipment which makes superfluous the time-consuming composition. Transportation and storage could cause problems. But we are prepared for this. For a while we will store the finished books here in so-called stage form and when the Budapest International Fair closes we will ship a thousand "stages" from here and from our site on Kozma utca to a rented pavillion."

The new telephone book will be obtainable this fall. And the experts promise that it will not be necessary to wait a decade for a new one because we will receive fresh ones every three or four years.

8984

CSO: 5500

ELECTRONICS EXPERT DISCUSSES TV TRANSMISSION BY SATELLITE

Bucharest VIATA STUDENTEASCA in Romanian No 12, 22 Mar 78 p 12

Interview with Prof Dr Eng Alexandru Spataru, head of the Applied Electronics Department, Faculty of Electronics and Telecommunications, Bucharest Polytechnical Institute, by Dinu Flamand

Text Question I know you played the decisive part in building our first black and white TV station, and so to begin with will you please say a few words about those pioneer times?

Answer In the 1950's I was the technical director in the Ministry of Posts and Telecommunications, when I officially recommended the introduction of TV in Romania. You must know that the idea met with serious objections. There were other more important considerations and priority investments for the Romanian economy at the time. There were shortages of clothing, footwear and foodstuffs. Who should worry about TV? But in the meantime I left the technical directorate and founded a research laboratory, also in the ministry. Without anyone's knowledge I and a few enthusiastic young collaborators built the first TV station in Romania outside working hours, using largely improvised equipment. This station operated experimentally in Bucharest for almost a year for the few TV sets in existence at the time, but it hardly demonstrated how effective TV can be from the standpoints of propaganda and information. When TV was approved, we were all astonished by the fantastic rate at which the number of TV sets increased, namely 10 times that of radio sales. Our laboratory then gave up some of its equipment, which was shipped to the mountains to reach Moldavia.

Question When did your efforts on behalf of color TV begin?

Answer At about the same time. The first studies and experiments on subassemblies were made in 1955, in the course of some doctoral programs I was supervising. Later on the Bucharest Polytechnical Institute specially formed a research collective to work on this problem, and the needed equipment for the first telecasts in color was made there.

Question I know there are several color TV systems in the world. Which one of them do you prefer?

Answer A great many countries have made studies of color TV, on the basis of which several systems have been developed. It took a long series of international conferences, which I attended myself on behalf of Romania, to facilitate the international exchange of programs. They decided to give international recognition to only three systems, namely the NTCS, SECAM, and PAL systems developed by the United States, France and the FRG respectively. Personally I prefer the first system for its outstanding technical qualities.

Question As a TV subscriber myself, I am curious to know when we shall have color TV.

Answer All our studies at the institute on the subject of color TV were forwarded some time ago to the industry and Radiotelevision. All the arrangements have been made to start color telecasts, and even though I cannot give you a definite date, you may be sure that it is not far off.

Question I would like to know when there will be more nationwide TV programs.

Answer It is true that we now need more TV programs for all Romania. But this would be very expensive with conventional techniques (by radio relays and surface transmitters). However the extraordinary progress made in space technology may permit nationwide TV programs from a satellite transmitter.

Question In what stage are the studies for adopting this new technique?

Answer A broad research program for implementing the new technique has already started. But there are many unsolved research problems and we have to prepare the best possible models, because no hasty solution can be corrected in progress. National transmissions by satellite have already been regulated by international treaties. The Geneva Conference of February 1977 determined for each nation the position its national satellite may occupy in the equatorial plane. The maximum number of channels per country was regulated at the same time. Romania was allocated five TV channels, which can also be used for high-quality radio broadcasting, on a satellite placed in the position 1 degree west. At certain points up there in space it has become so crowded that there is almost not enough room left for all nations, so that Romania is in the same position as some 10 more countries in approximately the same latitude.

Question You represent Romania at international conferences like the ones you mentioned. In what stage are the agreements on satellite transmission of international TV programs?

Answer The first steps are being taken, but quite hesitantly. Think of the propaganda power of TV and you will realize that this idea cannot yet take effect in a world with so many interests in dispute. But I do not think internationalization of TV programs can be held up forever. It is in the nature of things. There will be a veritable information revolution. Let us imagine for example that a citizen of Tahiti presses a button and receives the programs of the USSR, the United States or other nations by a simple maneuver. With three or four satellites all national telecasts can actually be transmitted from any country to any country. For the time being this is meeting with serious

political obstacles, and I think the only solution now is to refer this problem to the United Nations and to put it in charge of the international exchange of TV programs transmitted by satellites, for the benefit of all nations.

Question I am sorry to hear what you say. Apparently we have unlimited possibilities today but science must often await the results and verdicts of treaties... But tell me, do we still have telephone communication with America by cable?

Answer No, we no longer talk by cable. Now a space telecommunications station, connected to the international INTELSAT system, is operating very efficiently on Romanian territory. It enables us to talk directly by telephone across the ocean and with the countries in the Near East. These communications have a high fidelity.

Question Before coming to the department I took an interest in your works. As any student here knows, you are the author of the two volume work, "Theory of Data Transmission." Please tell me about these works, which are considered basic in their field.

Answer I wrote them rather late, you see. For all these years I had to consider practical problems first, although I was educated as a theorist originally. I was asked for practical solutions in the fields of TV, radio relays and the various transmission systems, and all these invariably involved me in intensive theoretical studies. At one point I was considered for admission to the Academy but I was rejected then because I had published no theoretical works. It was an irony of fate, but also quite true. This infuriated me and I got out the first volume of the said work in record time. I wanted to show all I had learned during the years when I was asked to find so many solutions to complicated problems. The first volume was published in 1965 and the second one shortly afterward. To my astonishment, and I say it in all sincerity, the book was a great success. It was hard for me to believe. Soon the work was printed in France, the FRG and the GDR, and then I was pleased to find that some renowned polytechnical institutes in Switzerland, Italy, the FRG, France, Algeria and other countries were guided by my treatises on this subject. I think the work enhanced my international prestige. I am a consultant of the International Telecommunications Union under the United Nations and a member of the management of the International Council for Communications Between Computers.

Question What are you doing now?

Answer I am working on problems of rationalizing the data transmission systems in their entirety and on processes of modulation, codification and statistical decisions, including in these efforts some aspects of long-distance data processing and of condensing data.

Question You were speaking of an inevitable information revolution. Are there already any indications of it?

Answer The volume of information transmitted today is already vast. Specialists are now confronted with the complicated problem of condensing the data.

From the strictly technical standpoint, all the existing systems transmit much more than the necessary and essential information. From our simple telephone conversations to the already codified data, all the present transmissions are inefficient. Condensing the data transmitted by the present transmission systems is one of the current efforts.

Question You have mentioned several times your collaboration with young researchers and students. Do you still encourage this today?

Answer Certainly. I would like to stress the fact that all my collaborators have been and are young, some of them just out of college. The students have also been helping me, and my office is always open for any problem. I am quite convinced that students should be intensively used in research along with experienced researchers. My own experience tells me that this can be done very successfully. Students of today are very interested in intensive study of the basics of electronics and particularly the basics of data transmission. These disciplines open up extensive possibilities for implementing the data processing and transmission systems. In the present developmental stage of the technology, the problems of electronics have become so complicated that they can no longer be solved by experiments alone. Whole theoretical disciplines are required, especially mathematics, but I say again that the students of today are better prepared than ever.

Question You have many other functions besides that of department head at the institute. Please name them.

Answer My main function is at the institute, but I have been active in the National Council for Science and Technology since it was founded. I am now the deputy chairman of this council and chairman of the Romanian Commission for Space Activities, which coordinates all space activity in Romania and our international relations concerning space problems.

Question Can you give us a few details concerning these activities?

Answer It seems strange for a country with limited economic resources to be active in this field which, as you know, is reserved for the great powers, but I should tell you that outer space is now considered international (See the UN Charter), and it has been demonstrated that major economic benefits can be obtained from these activities. Short of overlooking the scientific aspects, our main space effort is to apply space technologies to our national economic development. For instance, the space telecommunications station I mentioned has been built, data transmitted by meteorological satellites is being processed to improve weather forecasting, and we have begun to use data transmitted by long-distance detection satellites to discover underground resources in geology (ores, thermal waters etc.), in agriculture (to evaluate the strength of the harvests), and in other fields as well. But Romanian space activity is in full progress, a fact that will be proved true in the near future.

5186

CSO: 2700

YUGOSLAVIA

NEW INTERNATIONAL TELEPHONE EXCHANGE OPENED IN LJUBLJANA

Metaconta 10-C Automatic Exchange in Operation

Ljubljana DELO in Slovenian 26 Apr 78 p 1

[Article by Ilija Bregar: "'Faster' Telephony"]

[Text] Ljubljana, 25 Apr--Yesterday Ljubljana received an international telephone exchange directly connecting with 18 European countries. With today's official dedication of a new international automatic tandem telephone exchange of the Metaconta 10-C type [combination rotary and crossbar exchange developed by ITT] the Slovenian capital obtained direct telephone connection with 18 European countries. The opening formalities were attended, among others, by France Popit, president of the Central Committee of the League of Communists of Slovenia; Mitja Ribicic, president of the Republic Committee of the Socialist Alliance of the Working People; Zvone Dragan, vice president of the Executive Council of the Socialist Republic of Slovenia; and Vladimir Logar, vice president of the SRS Assembly.

The international automatic telephone exchange in Ljubljana is the third of its kind in Yugoslavia, the other two are in Belgrade and Zagreb. From now on more than 70 percent of telephone subscribers in Slovenia can direct dial telephones in Greece, the Netherlands, Belgium, France, Spain, Hungary, the GDR, Switzerland, the Czechoslovak Socialist Republic, Great Britain, Denmark, Sweden, Norway, Poland, the FRG, Luxemburg, Finland, and Malta. By the end of July direct dialing to Austria and Italy also will be available.

A section of the exchange is designed to handle 3,534 toll calls simultaneously but at present its operational capacity is 1,760 toll calls. The international part of the exchange is designed to handle 324 international circuits. International toll charges will be 55 para for 2 seconds to neighboring countries and 55 para per second to all other countries.

The campaign for construction of the new Ljubljana exchange began as early as 1970. The original plans called for completion in 1974. It should be mentioned, however, that this term was unrealistic because Iskra, which contracted to supply to the Yugoslav Posts, Telegraph, and Telephones 13 out of 17 of the Metaconta 10-C type tandem exchanges, first had to set up a new factory in Kranj before these semielectronic computer-controlled exchanges could be manufactured.

The building housing the new international automatic tandem exchange has an area of 4,500 square meters and cost almost 103 million dinars. The exchange alone cost 140 million dinars so that the total investment amounts to 243 million dinars. Another way to express the value of this exchange is to say that it is worth as much as 270,000 telephone services. (How calls to foreign countries are placed is described on page 11 of DELO.)

Dedication Speech by Zvone Dragan

Ljubljana DELO in Slovenian 26 Apr 78 p 6

[Text] Ljubljana, 25 Apr--The achievement of Iskra is important not only for the development of telephony but also opens development opportunities to all economic and social activities. "Today's dedication of the telephone exchange type Metaconta 10-C which was manufactured mostly in Elektromekhanika of Kranj under the licensing agreement with the Belgian firm Bell is an example of the unexpected technological development achieved by Slovenian industry in the field of communications equipment," said Zvone Dragan, vice president of the Slovenian Executive Council, at today's dedication of the new modern transit and international telephone exchange in Ljubljana.

"At the same time it is proof that an even more intensive orientation toward professional electronics outlined in the society's plan of SR Slovenia for 1976-1980 is an unquestionable necessity if we want to remove slowdowns in development as well as in completion of the telephone network in SR Slovenia.

"Dedication of the telephone exchange in Ljubljana is thus primarily the beginning of an era in which we wish to achieve a modern concept of communications as well as the beginning of an era in which we shall utilize technological advances to an even greater extent than has hitherto been the case so that we may with the computer-controlled switching system Metaconta 10-C, mastered and further developed by domestic industry, open even wider the door to our telephone communications which connect all points of the world with satellite links. The Metaconta 10-C program is of great importance not only for the development of telephone communications to which it opened new horizons, it also enabled Slovenian industry to master the most demanding technology in the production of processing computers of considerable capability. Its importance thus extends further than PTT communications and

electronics production because it is a product that opens new opportunities to all economic and social activities.

At a time in SR Slovenia when we are intensively concentrating on achieving the concept of our planned information processing and computational system it is appropriate to ensure society's cost effectiveness in all areas by coordinated action and at the same time achieve compatibility of the entire system. Accelerated development of communications traffic and the professional electronics industry, including production of data processing equipment, is certainly the foundation on which we are basing one of the most important development principles which will in future years ensure the greatest possible participation of domestic expertise in the joint Yugoslav projects," said Zvone Dragan.

Efficient Production of Computers

"In the agreement on the foundations of the 1976-1980 social plan for SR Slovenia SOZD Iskra assumed the specific obligation of mastering the production of computer hardware. At the same time it set as its goal to develop its capability for providing service to users of all kinds and sizes with a full spectrum of complete data-processing systems including both hardware and software. If SOZD Iskra with its telephone exchanges of Metaconta 10-C type demonstrated its ability in mastering the most intricate technological processes we can consider the year 1977 in which the contract on cooperation in business and technology and on acquisition of production rights was signed with the American firm Control Data Corp as the beginning of a new era in the technological development of Iskra.

Iskra decided on a partner whose equipment has been installed and tested in the republic computer center which represents practical assurance of its effectiveness primarily because it makes possible a rational and flexible buildup of society's information-processing system with, of course, substantial investment of domestic labor and know-how. This is why we feel that any duplication of computer production and promotion in SR Slovenia based on trade relations and domestic assembly, particularly if it were without significant contributions of domestic know-how would be inefficient from society's point of view and hence unnecessary.

Development That Also Represents a Firm Foundation for a Modern Telephone Network

Production of computer hardware is, accordingly, one of the important development objectives. Therefore we expect that a program involving established research institutions such as the Jozef Stefan Institute and the Electrical Engineering Faculty will lead to integrated domestic production of hardware and software for data processing and business information systems which will be the starting point for the development of an information and computer network interconnected with remote terminals, that is, a network in which modern communications are assuming an exceedingly important role and place. Communications network, data-processing equipment, and

experts represent a triangle in which we wish and must resolve numerous developmental questions," said, among other things, Zvone Dragan at the dedication of the international telephone exchange.

Metaconta 10-C Operating Details

Ljubljana DELO in Slovenian 26 Apr 78 p 11

[Text] Introducing Automatic International Toll Telephone Communications in Slovenia

After the new international and transit telephone exchange in Ljubljana has been put in operation most telephone subscribers in Slovenia can dial direct subscribers in the following states:

Greece	99 30
The Netherlands	99 31
Belgium	99 32
France	99 33
Spain	99 34
Hungary	99 36
German Democratic Republic	99 37
Switzerland	99 41
Czechoslovakia	99 42
Great Britain	99 44
Denmark	99 45
Sweden	99 46
Norway	99 47
Poland	99 48
Federal Republic of Germany	99 49
Luxemburg	99 352
Finland	99 358
Malta	99 356

The numbers opposite to the states represent the outward dialing number (from the Socialist Federal Republic of Yugoslavia).

Example: To call the telephone number 12 34 56 in Berne, Switzerland one dials 99-41-31-12-34-56

--first dial 99--the international outward (from SFRY) dialing code

--next dial 41--the code of the desired country (Switzerland)

--then 31--the network area code for Berne

--and finally 12-34-56--the telephone number of the subscriber in Berne.

From the above example it is apparent that one must know in addition to the called party's number

--the international outward dialing code (99 for SFRY)

--the code of the country to which we are placing a call (in this case the code for Switzerland)

--the network area code of the called central office (number 31 in our example)

--the called party's number (12-34-56 in our example).

International direct dialing will be available to subscribers in the following central offices.

Ljubljana: area code 061; district exchanges and subexchanges in the local network of the City of Ljubljana.

Maribor: area code 062; district exchanges in the local network of Maribor and exchanges Fram, Hoce, Lovrenc na Pohorju, Orehova vas--Slivnica, Pekre--Limbus, Pernica, Pohorje, Race, Ruse, Sentilj v Slovenskih Goricah, Zgornja Kungota, Lenart v Slovenskih Goricah, Prevalje, Crna na Koroskem, Mezica.

Celje: area code 063; exchanges Celje, Dobrna, Rimske Toplice, Strmec pri Vojniku, Store, Vitanje, Vojnik, Sempeter v Savinjski dolini, Petrovce, Polzela, Prebold, Vransko.

Nova Gorica: area code 065; exchanges Nova Gorica, Anhovo, Branik, Dobrovo v Brdih, Dornberk, Kanal, Kojsko, Kostanjevica na Krasu, Cepovan, Miren, Sempas, Sempeter pri Gorici, Trnovo pri Gorici, Volcja draga, Ajdovscina, Col, Crnice, Dobravlje, Podnanos, Vipava, Tolmin, Bovec, Breginj, Kobarid, Klavze, Most na Soci, Podbrdo, Tolmin, Cerkno.

Koper: area code 066; exchanges Koper, Ankaran, Crni kal, Dekani, Marezige, Slovensko Gracisce, Skofije, Smarje pri Kopru.

Postojna: area code 067; exchanges Postojna, Hrusevje, Kosava, Pivka, Planina na Rakeku, Prem, Prestranek.

Subscribers in Ljubljana can obtain information on how to place international telephone calls by dialing 901 or 988 and subscribers in Maribor, Celje, Koper, Postojna, and Nova Gorica by dialing 988.

International telephone calls to other countries and from places in Slovenia where direct dialing is not yet available should be placed in accordance with the previous procedure, i.e., by dialing 901 in Ljubljana, Maribor, and Nova Gorica and 900 elsewhere.

The public will be notified by information media as other places in Slovenia are gradually included in the international direct dialing system.

12070
CSO: 2800

SATELLITE TELECOMMUNICATIONS GROUND STATION OPENED

Brazzaville LA SEMAINE AFRICAINE in French 7 May 78 pp 6, 7, 16

[Excerpt] On Friday morning, 28 April, a satellite telecommunications ground station was opened in Brazzaville, at a pleasant site away from any radio interference. To reach it, one leaves National Highway 2 at kilometer 17 to follow a road built expressly for that purpose that crosses the Tsieme River over a specially built bridge.

It seemed to us that it would be of interest to all our readers--beyond the solely Congolese interest of the event that we shall report--to go into the technical aspects of a satellite telecommunications ground station.

In fact little by little our African countries are all going to be connected to this telecommunications system. Gabon, Zaire, and Cameroon, to mention only our immediate neighbors, already have their ground station, Chad's station is under construction, and one is planned as well in the Central African Empire (which had one temporarily at its disposal for the Bokassa I coronation festivities).

The first part of our report will therefore be technical in nature. The second part will deal with the dedication ceremony.

Questions of Waves

Up until a relatively short time ago, international telecommunications traffic was routed by radio using decameter waves, that is to say, having a length of several tens of meters--think in terms of the 16-m, 19-m, 25-m, 31-m, etc. bands of our radio receivers.

These short waves are peculiar in that they are reflected by layers of the earth's upper atmosphere and return to earth, where they again bounce skyward. After several successive ricochets between sky and earth, they may reach receivers that the roundness of the earth completely shuts off from the horizon of the transmitting station. In that way we receive the broadcasts of Radio-France, the Voice of America, or Moscow.

But there are two drawbacks. The airwaves are very congested, and it is difficult for radio waves to clear a path for themselves. Then during the day and especially during intense solar activity, the upper atmosphere undergoes changes that partially absorb the waves and do a poor job of sending them back toward earth. On the other hand, everyone has noticed that distant radio reception is much better after sunset.

For that reason, for continuous intercontinental communications it seemed necessary to use ultrashort waves and communication satellites. In fact, ultrashort waves pierce the upper atmosphere and reach a satellite which sends the broadcast back to earth. To do so, it is necessary to have satellites. This is very expensive and is beyond the capabilities of most countries. On the other hand, it becomes possible if everyone bands together. Therefore, the Congo joined the international organization INTELSAT which has a whole chain of satellites. INTELSAT now has 101 member states; the Congo has belonged to it since 26 October 1977.

This organization places several geostationary satellites at the disposal of the user countries. What does this involve?

At a distance of about 35,800 km from the earth, a satellite possesses a velocity that keeps it in balance at that distance in the earth's gravitational field. It orbits the earth in 23 hours 56 minutes, which corresponds to the time that it takes our globe to make one complete average revolution about its axis. If an object is placed in orbit at that altitude above the line of the equator, it will appear to observers to be stationary with respect to the earth (geostationary).

Now intercontinental communications are facilitated by this system to the extent that they become theoretically continuous. In fact, it is sufficient to place satellites in 120-degree orbits with respect to each other (the 360 degrees of a circle divided by three) for every point on the surface of the earth to be within the cone of action of one or the other of these relay satellites. In reality there are more than three of them. INTELSAT has three or four of them above the Atlantic Ocean alone.

The INTELSAT satellite to which the Congo is linked is of type IV a; it weighs 798 kg and can relay 6,250 telephone communications and two television programs at the same time.

This satellite is in contact with 68 ground stations which, like the Congolese station at Mougouni, have their antennas continuously aimed in its direction.

An Antenna That Is Somewhat Special

The Mougouni ground station is therefore nothing more than a gigantic antenna that receives or transmits broadcasts through an INTELSAT satellite.

Actually the ground station is a complex consisting of the antenna proper, an operations building, administrative offices, and a power building.

The most spectacular part of the station is obviously the antenna itself with its parabolic reflector (gigantic ear for listening to the world...) which has a diameter of 32.50 meters. In normal operation it is automatically aimed at the satellite by means of a system that detects the tiniest changes in the position of the INTELSAT. In case of failure of the satellite used, the antenna could be reaimed in a few minutes at a backup satellite.

Directly beneath the antenna is the building housing the receiver and transmitter amplifiers as well as the antenna control devices.

The installations in the power building include, in particular, two automatic generator units which insure a continuous power supply and thus prevent any interruption in station traffic.

The station is connected to the terminal center situation in the building of the Congo International Telecommunications Office (INTELCO; director, Jean-Gabriel Okeli), located in the center of Brazzaville, by a microwave link which provides telephone and television connections at the same time. The television is then transmitted to the television studios by a special microwave link.

What Can the Ground Station Be Used For?

Priority is given to the use of the Moungouni ground station for international communications by telephone, telegraph, and telex. This station has two channels. The first one is assigned solely to the types of communication that we have just mentioned; the second channel, called emergency channel, is used to transmit television signals. It is by this channel that the Congo can receive broadcasts from the entire world and transmit Congolese telecasts worldwide (this is what is called mondovision). However, since this station has only two channels, assuming that the regular channel becomes unusable, the telephone communications (telegraph, telex) automatically go through the emergency channel for they take priority over any telecast, which then becomes momentarily impossible.

We said that the INTELSAT satellite simultaneously has at its disposal 6,250 communication circuits. Out of this total, the Congo has reserved 24 for itself, and it "rents" them by an annual fee paid to the international organization INTELSAT.

On the other hand, telecasts are paid for item by item. It is necessary to pay at the same time for rental of the satellite and retransmission rights to the telecast, which may belong to a particular state or to an organization. So it is that a large portion of the money collected by the city of Montreal, Canada, to pay the costs of the last Olympic Games came from television retransmission rights to the Olympic Games throughout the world

(even so, the deficit was enormous...) For example, the retransmission of a soccer match directly from Europe or America is obviously very expensive. But if this match is made available on a delayed basis (for example, if the match is retelevised the next day), the cost is lower. It is, in fact, proportional to the number of television sets in the rebroadcasting country.

For the moment, the Moungouni ground station provides direct telephone connections (telegraph, telex) with France, the Ivory Coast, and Gabon, and indirect connections, by appropriate relay system, with the rest of the world. But other direct communications will be opened later.

The Congo can receive all telecasts relayed by satellites situated above the Atlantic, and therefore telecasts from Africa, Europe, and America. Later there will be a connection with satellites covering the Indian Ocean (and therefore Asia).

Who Financed the Ground Station?

In June 1975 President Joachim Yhomby-Opango, then minister of national defense as well as post office and telecommunications, had opened negotiations with France for the financing of a ground station project. These negotiations proved successful. France granted (through the Aid and Cooperation Fund and the Central Fund for Economic Cooperation) loans at advantageous rates of interest, repayable in 13 years. It was in that way that it was possible to find the Fr 2.5 billion CFA [African Financial Community] that the ground station cost.

The station was built through a "keys-in-hand" order placed with the French economic interest group TELSPACE. In France there are two large companies that make electronic equipment--the CGE [French General Electric Company] and Thomson CSF.

To compete with the American giants and against the monopoly of the two heavyweights in the space telecommunications domain, the CEG and Thomson CSF together formed an "economic interest group" which took the name TELSPACE, with each one holding 50 percent of the capital.

TELSPACE has become the most important company in Europe in accomplishments. Thomson CSF has a great deal of experience in the domain of electronic components and complete equipment. Such equipment, highly diversified and of high engineering quality, includes radio and television transmitters in particular. Iran, Chile, Tunisia, Algeria, Morocco, Gabon, Zaire, the Congo, and undoubtedly many others use Thomson CSF television equipment.

The main equipment of the Moungouni ground station comes from CIT-Alcatel and Alsthom-Neyrtec in addition to Thomson CSF.

The official opening of the ground station took place on Friday, 28 April, at 1000 hours. The Congolese chief of state, whose role in the birth of

this station we have mentioned, was obviously present in person. Gen Yhomby-Opango was accompanied by the two vice presidents of the CMP, Col Denis Sassou-Nguesso and Col Louis-Sylvain Goma. Major Raymond Ngollo, the chief of staff, was at the ceremony, as, of course, was Minister of Information and Post Office and Telecommunications Capt Celestin Goma-Foutou.

As always on such occasions, there were many speeches--by Jean-Gabriel Okeli, director of INTELCO; by Mr Ducros, on behalf of TELSPACE; by Bertrand Dufourcq, the French ambassador; and by Capt Celestin Goma-Foutou, minister of information and post office and telecommunications.

We have selected two passages from the address by the minister of post office and telecommunications that seem to us to sum up very well the two aspects, policy and economics, of the opening of the ground station:

"With the improvement in international communications between the Congo and the other countries of the INTELSAT network, cooperation is going to be strengthened, for a country or a region where communications are easy attracts more enterprises and investments than a country or a region which has none. What is true for the foreign investor is also true for the national investor, who will be able to overcome distance thanks to the ease of communications.

"The ground station should not be viewed as an instrument aimed essentially at Europe or the other continents. It is also a tool that will increase our cooperation with the other African countries which in spite of being closer to us were alien because of the preference that was shown for our ties with our former colonial powers. In fact, it is not frequently true that mail takes more time to travel 300 kilometers in the country than to go 6,000 km between our African capitals and any European provincial city?"
(...)

"In fact the acquisition and putting in operation of telecommunications equipment requires large investments, and the payment and especially liquidation of these investments within a reasonable time is the only hope of survival of the investing enterprise." (...)

"Now, what purpose would be served by the heavy financial sacrifices that the department of post office and telecommunications is agreeing to make if the benefits and services rendered to the users were not paid back in just measure?

"That is why I should like to take this solemn occasion to appeal to the professional consciousness of the INTELCO workers, on the one hand, and on the other hand to the magnanimous and militant understanding of all officials of the public and financial services with regard to the need for doing everything to see to it that the bills for telephone charges are honored."

In addition to viva voce communications, there is, of course, communication by satellite! Let's see if it is working! Yes, it's functioning perfectly! Capt Goma-Foutou demonstrated it by calling his French counterpart in Paris, Mr Norbert Segard, secretary of state for post and telecommunications. This call was received in France by a ground station of the same type as the one at Mougouni, situated close to the city of Troyes, at Bercenay en Othe, and it was officially opened by that telephone call from the Congo...

7428

CSO: 5500

GHANA

BRIEFS

PAN AFRICAN TELECOMMUNICATIONS--Accra, 17 May--Within the next few months Ghana will begin construction work on its section of the Pan African Telecommunications network that will link all the African states. This was stated on Tuesday evening by Mr E.R.K. Dwemoh, Ghana's commissioner for transport and communications. He was speaking on the occasion of the tenth anniversary of International Telecommunications Day and he said that the Ghanaian section extended from the border with the Ivory Coast to the West and the border with Togo in the East, but he gave no exact details about the length of construction work. The scheme is under the direct control of the International Telecommunications Union, and apart from this Ghana has already begun construction work on an earth satellite center that will improve communications. [Text] [Accra GNA in French 1530 GMT 18 May 78 LD]

CSO: 5500

COMPUTER INDUSTRY DEVELOPMENTS, FUTURE DETAILED

Competitive Market

Johannesburg SUNDAY TIMES in English 21 May 78 p 7

[Article by Peter Godsell: "War Looms as Biggies Move into Minis." Godsell, director of Leonard Fine Associates, a company specializing in computer consulting and computer market research.]

[Text]

MARKET RESEARCH has confirmed that there is burgeoning growth in the market for small computers and a leveling off in the market for their bigger counterparts.

And in South Africa, where there are almost 30 companies supplying as many as three makes, a commercial war is expected in the small computer market. This should be characterised by hardware price reductions and continuing aggressive moves into the sector by the suppliers of big computers.

The computer market in this country is constantly changing, not only in terms of an increasing flow of new,

better and cheaper products, but also in terms of the computer supplying companies.

In the past few years we have seen companies come and go, franchises change and various mergers. And although this tempo of change is greater in the smaller computer companies, it is certainly not restricted to them.

We have seen companies such as Honeywell and Siemens enter the market and then depart, perhaps to try again. The giant ICL took over the Singer Business Machines market and some of the big American companies have established themselves as forces in the market only recently.

The turbulence in this industry has not stopped. Al-

ready this year a number of new computers have been introduced, such as PRIME, being marketed by the Institute of Software Technology, and the Syfa, which is being introduced by Data Management Systems.

Is this ever-changing industry likely to begin stabilising soon? Not in my view. The rapidly changing technology and continual release of new products tends to encourage rather than discourage the birth and death of supplier companies.

The industry can be divided into three categories:

- The big international companies which have been supplying the mainframes. Many of these firms have extended their product

range to cover the small computer market.

- Subsidiaries of international companies which specialise in minis.

- Primarily South African companies which have obtained franchises or multiple franchises for computers of overseas origin. The biggest portion by far of the mini-computer market is held by supplying companies in this category.

In addition, in the past year, a local manufacture/assembly industry has begun to develop in the Republic, spearheaded by the Messina (Electronic) Development Company.

The trend towards smaller and cheaper computers continues relentlessly. In the past decade, the costs of the electronic components of computer equipment have plummeted as a result of mass production and of miniaturisation.

This trend has created substantial new opportunities for the industry by way of an expanding market of increasingly smaller user companies, as well as the geographic distribution of small computers in big organisations.

It has, however, also attracted to the industry the very serious problem of how the support demands of this bigger market can be met economically.

The so-called "mini-market" was originally developed by the smaller computer companies which specialised in terminals and, growing out of that, mini computer systems. These companies enjoyed phenomenal growth in the early years when there was relatively little competition from "the biggies".

However, in the past two years, the international mainframe suppliers have begun to move into the mini market with a vengeance. New products such as the IBM System 32/34, the Burroughs B80/B800 and the NCR 8100/8200 have been a declaration of war by the big companies. With about 30 suppliers involved in the struggle for the custom of small computer users, this will be a war of many battles.

In the past year, certain trends have manifested themselves:

- A far greater proportion of computer users are seeking competitive quotations from a number of suppliers before deciding on the purchase of new equipment. Hence the competition per deal is increasing.

- The variation between prices for comparable systems from different suppliers has decreased dramatically. Both suppliers and customers are becoming extremely price conscious.

Both of these are merely indications of the commercial war that is being waged for the small computer market.

Why this market in particular?

Market research overseas by organisations such as Pedder Associates, as well as research being done by Leonard Fine Associates, is highlighting the fact that both here and abroad the growth of the mainframe computer market is beginning to slow down.

On the other hand, the market for small computer systems is still in a product establishment phase and is enjoying an extremely high growth rate. Apart from the

services market, the terminal/small computer systems will provide the fastest growing segment of the computer industry in the next few years.

With such a big and growing market there must certainly be room for many suppliers, but with the high level of competitive activity one wonders whether all the competitors can survive.

What of the future?

Many people in the industry are prognosticating a slow-down in the rapid change of hardware technology. However, there is little evidence to support this belief.

Should this slow-down happen, it would certainly be a blessing to the industry, because it would provide a period of stabilisation during which some of the real problems could be attended to.

Although the cost of equipment has continued to decrease, the costs of people-intensive support activities (such as programming and equipment maintenance) have escalated with inflation. Thus, the ratio between cost of services and cost of the actual equipment is getting increasingly wide.

A great deal will be needed to either solve this problem or re-orientate the marketing and pricing policies of the computer supplying companies.

When you buy a box of razor blades you are often given a razor free of charge; perhaps one day you will buy a set of computer programmes and a service contract and the actual computer will be thrown in as an afterthought!

Staff Shortage

Johannesburg SUNDAY TIMES in English 21 May 78 p 7

[Text]

SOUTH AFRICA'S computer staff shortage shows no sign of ending and only an intensive commitment to staff training and productivity holds any hope of easing it.

That is the warning from Computer personnel of Johannesburg, the country's biggest computer staff selection consultancy.

"The continuing shortage has hamstrung the computer industry's growth in South Africa, has pushed computer staff salaries to a point where an investment in data processing has become expensive for many companies and has emphasised the need to train and re-train the industry's people," says CPL Director Don Gray.

The current shortage in an industry employing more than 11 000 people is estimated at close to 2 000.

And because of it, Mr Gray points out, the growth of the industry so far has been just a fraction of its real potential.

The continuing development of mini-computer and micro-computer hardware, and the reduced cost that its development brings, promises to put computer power eventually within the reach of even the smallest companies.

At the same time, the computer's ability to provide business management with more and more low-cost information is as much in demand by companies who want to capitalise on their success as it is by ailing companies which want to cure their ills.

Yet, while the industry can readily acquire all the hardware it wants, it lacks the people it needs to produce the software to go with it.

As the industry continues to develop — however hampered it may be — its staff needs are expected to split distinctly.

Computer people with an appreciation of business strategies will need to concentrate their talents on manipulating that ability to the optimum benefit of the company using it.

"Companies," Mr Gray warns, "must not only devote a big share of their computer budget to staff training, but give attention to the professional management of those trainees.

"Shortages will keep pushing salaries up. Data processing will remain expensive. And the chances of its growth will be retarded.

"The immediate need is for the industry to use the talents of its people as productively as possible," says Mr Gray. "It can ill-afford anything less."

Sanctions Ineffective

Johannesburg SUNDAY TIMES in English 21 May 78 p 9

[Text]

IN THE EVENT of sanctions being imposed would South Africa be able to meet its computer industry needs locally?

"Up to the mini-computer level, yes, without a doubt," says Peter Abery, general manager of Messina Electronics.

"Beyond that, however, the complexity of computers increases exponentially, making it difficult to go further in terms of local manufacture.

"This would not leave South Africa vulnerable, however. Most defence applications could be within the capacity of a locally made mini-system. The same applies to industrial applications including process and numerical controls for the production of vital equipment."

Mr Abery said cost and low volumes precluded Messina from going much beyond the 85 or so per cent of local content currently

achieved in its Commander system, although in the event of sanctions the strategic considerations would override those of cost.

"The Commander was designed by Messina's engineers and the only items not produced locally are the more sophisticated integrated circuits. Given the necessary incentive and resources, however, South Africa could make its own computer chips.

"The other essential items such as printers and off-line storage could similarly be produced here," he said.

One year after start-up Messina has an order book of more than R600 000.

The company has just introduced an upgraded version of the Commander, and was recently able to reduce its prices by between 10 and 15 per cent. This brought a typical standard system into the R15 000 to R20 000 range.

SOUTH AFRICA

BRIEFS

RECORD SALES FOR ICL--BRITISH computer company ICL is racing towards another record sales year in South Africa. By the end of April, seven months into the current financial year, hardware sales of R35,1-million were more than two-and-a-half times as great as in the same period of 1977. With a target of R52-million for hardware sales this year (compared with R41-million achieved last year), ICL is already two-thirds of the way there. Total South African turnover last year, including software, servicing and bureau operations, was R67-million, which was 10 per cent of ICL's world-wide turnover. One reason for the boom, according to small systems brand manager Graham Bendell, is the company's good stock position. "Some of our competitors have been extremely active with new products," he said. "This stimulates interest in computers, but people don't always want to wait eight months for supplies--and we can supply ex-stock." Mr Bendell also feels that there has been a return of business confidence upon which British companies, so far unaffected by serious sanctions threats, have been capitalizing. ICL South Africa is 93 per cent held by ICL of Britain with the rest held locally. ICL Equipment Finance, which finances equipment purchases, is quoted on the Johannesburg Stock Exchange and 74 per cent of the equity is locally held. [Text] [Johannesburg SUNDAY TIMES in English 21 May 78 p 1]

CSO: 4420

CURRENT BROADCASTING DEVELOPMENTS AND GOALS DISCUSSED

Moscow VESTNIK SVYAZI in Russian No 4, Apr 78 pp 2-5

[Article by Ye. Ye. Dobrovol'skiy, Deputy Chief of Main Control for Space and Radio Communications and associate professor: "Radio and Television Broadcasting and Space Communications in the Tenth Quinquennium"]

[Text] At the 25th communist party congress, in his report "An Accounting of the Central Committee of the KPSS and the party's next tasks in the area of internal and external policy," General Secretary of the KPSS Central Committee Leonid Il'ich Brezhnev stressed, "The orientation of all branches of the economy and the work of each ministry and enterprise towards a determined improvement in efficiency and quality is now, comrades, of greatest importance." This program position of our party has direct application to the development of all the media of the communications field.

Radio and television broadcasting, and in recent years also space communications, have permanently entered the life of our nation. And that's not surprising -- why our country is radio's native land. Radio Day has become a holiday for all radio operators now. Noting this holiday, we once again desire to examine our achievements and decide which tasks remain to be completed during the tenth quinquennium.

The ever growing role of the communications media, radio and television broadcasting has been reflected in the new constitution (Basic Law) of the Union of Soviet Socialist Republics (USSR). Article 46 states, "Citizens of the USSR have the right to use cultural achievements. This right is guaranteed by the development of television and radio." In article 50, it says that, "Citizens of the USSR are guaranteed the freedoms of speech, press, assembly and meetings.... The attainment of these political freedoms is insured by giving the workers and their organizations public buildings, streets and squares, through the wide dissemination of information, and the opportunity to use the press, television and radio."

"The primary course of development for the national economy of the USSR between 1976 and 1980," as affirmed by the 25th KPSS congress, "is provided for by ensuring the future development of radio and television broadcasting,

including color, and also the broader use of artificial earth satellites primarily to provide television broadcasting to western and eastern Siberia and telephone - telegraph communications with the remote regions of the country."

At the present time, tremendous successes have been achieved in creating the most massive and accessible medium for getting comprehensive information to the populace -- radio broadcasting which encompasses practically all the territory of our colossal nation. The Central All-Union Broadcast now carries eight programs for a total of 160 hours a day.

The organizational characteristics of the Soviet government and its linguistic structure require the availability of local broadcasting, aside from the central one, in the unions and autonomous republics, krays, oblast's and national okrugs. This is accomplished through numerous local radio broadcasting stations. At the same time, in each of the union republics there are two or three of their own republic programs. The total volume of radio broadcast transmissions in the last ten years has doubled and by 1977 consisted of more than 10 million hours.

Radio broadcasting represents a method for comprehensive utilization of all broadcast bands in the radio spectrum -- long, medium, short and meter.

To improve the hearability of radio broadcast transmissions in the long and medium bands, during the tenth quinquennium the introduction of so-called synchronous broadcast networks will be pursued. The advantage of such networks is the capability to operate many radio broadcasting stations on few frequencies. In the synchronous method of operation, the transmitting networks are organized from a whole group of radio broadcasting stations operating on a single frequency and relaying the same program.

If while operating on a combined channel (i.e., of broadcast transmitters working on the very same frequency but transmitting different programs) it is necessary to have a protective signal-to-noise ration of 30 db, then while operating on the synchronous network this ratio may be reduced to 8 db and at the same time the quality of the radio broadcasting transmissions remains fine. Synchronous broadcasting has permitted us to overcome the shortage of radio frequency channels and ensure future improvement in the quality of radio broadcasting in the long and medium bands.

The tangible economic efficiency from the adoption of the synchronous broadcasting method is very high, because without increasing the number of frequency channels being used the zones of population coverage are significantly expanded with insignificant additional expenditures for synchronization equipment. Thanks then to the reciprocal redundancy of the synchronously operating transmitters, the stability and quality of the operation of the entire network of radio broadcasting stations are significantly improved.

At the present time, 35 synchronous broadcast networks are operating in the Soviet Union. In the near future it is intended that quantum frequency standards -- rubidium or cesium, which ensure very high stability of the carrier frequency -- be employed as reference oscillators. Through their application the operational quality of the synchronous network will be raised, since the necessity for receiving frequency reference signals will become superfluous.

The condition of radio broadcasting which had come about by 1974 - 1975 in the long and medium wave bands led to the need to develop a new plan for distribution of frequency channels in these bands. In 1975 in Geneva, at the Regional Conference on Long and Medium Wavelengths a long-range plan, which will go into effect on 23 November 1978, was adopted for the allocation of frequencies in these bands over the next 11 years. According to the plan, there has been established a network of frequencies whose carriers are separated by 9 khz. This is most important for reducing mutual interference which exists with differing magnitudes of carrier frequency separation. In our country under this plan, the creation of new synchronous broadcast networks, the use of directional antennae to avoid mutual interference, the reduction of night time power by the radio broadcasting stations, etc. are all envisaged.

The long-wave (DV) frequency ratings for radio broadcasting stations remains unchanged, but the frequency ratings for medium-wave (SV) stations shift by 1 - 8 khz. Radio broadcasting station workers in the USSR must perform the necessary preparations and ensure that the new frequency ratings are smoothly instituted by 23 November 1978.

To improve the hearability and raise the quality of radio broadcasts on long and medium wavelengths during the tenth quinquennium, there will be brought into operation significantly more powerful radio stations compared to those which were constructed earlier under strict adherence to separated frequency channels and transmitter power limitations which had been established for USSR radio broadcasting stations under the 1975 Geneva plan for radio frequency allocation.

New radio stations will be built in Siberia, the Far East, in Kazakhstan and in Central Asia. Transmitters with a power rating of 1,000 kw, ensuring high electroacoustic properties and having a high industrial KPD (efficiency), as well as frequency stability and secondary emissions in accord with MKKR (International Radio Communications Advisory Committee) norms will be installed at these stations.

Industry is already producing an SV (medium-wave) radio broadcasting transmitter RV-1000S, with 1,000 kw rated power, permitting transmission on two fixed frequencies in the 525 - 1605 khz band and the 1,000 kw DSV (long-to-medium wave) "Tayfun" transmitter which is being adopted for central radio broadcasts.

During the tenth quinquennium, the 150 kw DSV transmitter PDSV-150 will be installed in central, republic, kray and oblast' radio broadcast transmitting stations, and for local broadcasting the 50 kw SV transmitters supplied by the Czech firm "Tesla" is one example of the realization of the policy of socialist economic integration.

During this quinquennium, new medium wave synchronous broadcast networks are being created using 5 kw SV transmitters of the PSV-5 type, which have been specially developed by the communications industry for installation at operational television transmitting relay stations. This makes it possible with minimal expenditures (since industrial space and buildings already on hand are being used) to achieve significant technical and economic efficiency. The 7 kw SV transmitters SRV-7 (a product of the CSSR) will also find wide application.

The distribution of PSV-5, SRV-7 and other transmitters directly in the cities ensures that the field intensity of the active signal will significantly surpass the noise level which allows for a qualitative improvement in medium wave reception of radio broadcast programs in the cities.

One of the main trends in technical progress in the area of providing high quality radio broadcasting is the creation and expansion throughout the country of a network of multi-program radio broadcasting stations operating in the meter wave length with broad band frequency modulation (MV-CHM stations). During the tenth quinquennium, approximately 100 new MV-CHM stations will be constructed and in general by 1981 they will number nearly 450. This will provide the cities and their surrounding agricultural regions with quality broadcasting and they will encompass more than 85% of the population of the USSR. This aspect of broadcasting has very great significance since the meter wave band is practically insensitive to atmospheric influences or industrial interference, and therefore can achieve excellent broadcast hearability.

The MV-CHM stations are used to transmit central broadcast programs I - III, and also for local broadcast programs conducted in the national languages of the peoples of the USSR.

Within the first two years of the tenth quinquennium, over 30 new MV-CHM stations have been put into operation. However, all the capabilities incorporated within the MV-CHM broadcast transmission network have yet to be discovered. The decisions of the 25th KPSS congress require broader adoption of stereophonic broadcasting which can be accomplished only by utilization of MV-CHM stations.

The stereophonic reproduction of sound improves its quality and gives the listener additional information on the location of the sound sources along a line "from left - to right", and the sound of the voices and musical instruments, at the same time, takes on a more natural character with the perception of their spatial arrangement. In 1977 stereophonic transmissions were already being produced in 25 cities through MV-CHM broadcast stations -- Moscow, Leningrad, capitals of the union republics, Gor'kiy, etc. Between

1978-1980, stereophonic broadcasting is scheduled to service another 14 cities of our nation.

One should note that the development and refinement of the technical means for a low-frequency radio broadcasting channel had a significant influence in improving the sound quality of radio broadcasting programs in all radiowave bands. At the present time, 171 radio studios are operating in the country. They all possess the necessary studio equipment complexes. More than 80 of these studios have been totally reconfigured with new transistorized equipment.

In the Olympic television building which is presently under construction in Moscow, the development of new radio broadcasting studios is envisaged. During "Olympiad-80," the transmission of 100 international radio broadcasting programs will be provided.

The branched network of cable and radio relay lines which has been created permits the transmission of central radio broadcast programs from Moscow to many of our nation's cities on special wideband radio broadcast channels and further relays them through local radio broadcasting stations. Future gains in reliability and improvement in radio broadcasting quality depend primarily on ensuring the continuous operation of wideband channels for supplying audio broadcast programs to the nation's radio broadcasting stations.

The highest quality and most promising channels for providing central broadcasting programs, especially to the country's remote regions during the tenth quinquennium, will be to an ever greater degree satellite radio communications systems' channels. Since 1977, the "Mayak" radio broadcast has been transmitted regularly on satellite radio communications channels to a number of remote areas throughout the country. By the end of the tenth quinquennium, the "Mayak" broadcast, as well as the First Program, will reach practically the entire population of our nation.

During the tenth quinquennium, the task of introducing equipment into the radio broadcasting stations to a significant degree must be accomplished through reconstruction and power amplification of the radio stations' operating equipment, with the adoption of progressive technical decisions and concurrent support for raising the sound quality of radio broadcast transmissions. In many radio enterprises, power amplification of DV, SV and KV (short wave) transmitters will be accomplished with the installation of new technical equipment in the space freed as a result of reconstruction at the radio transmitter sites.

Transmitter power amplification has a significant technical-economic effect in that it raises the price per transmitter channel hour, but it results in a significantly improved product in monetary terms. The number of service personnel, at the same time, remains unchanged or increases insignificantly so that growth in production leads to a sharp improvement in labor productivity at a given enterprise. The installation of new transmitters in the freed space at the radio enterprises also leads to growth in the productive

capacity of the radio stations, and consequently also to improving labor productivity.

The new "Regulations for Technical Operation of Radio Broadcasting and Communications Installations" (Moscow, "SVYAZ", 1977) which were developed by the Chief Directorate for Space and Radio Communications and have been in effect since August 1977, take the new technology, the increased quality requirements and operations efficiency all into account, as well as the experience of the leading collectives of scientific labor organizations. The high level of professional training and the specialized knowledge for maintaining and managing a radio broadcasting network, as set forth in the regulations, are the requisite conditions which guarantee the effectiveness of the specialists' labor in a radio enterprise.

Cable broadcasting (PV) together with radio broadcasting comprise the nation's unified broadcast network. The PV system provides for the reception and boosting of broadcast programs as well as their distribution with the assistance of the cable network through a subscriber arrangement. The combination of the powerful radio broadcast transmitting network which has more than 70 million wireless receivers with the branched PV network which also exceeds 70 million radio relay points resolves the country's radio installation problem with great efficiency and high quality. At the present time, more than 97% of the country's populace are reached by cable broadcasting.

The popularity of PV is explained by its ease of operation, the reliability and low cost of its subscriber arrangements, its anti-interference feature, good quality indices, and also the capability for transmitting local information. Presently, all the public and residential buildings under construction are being equipped with PV broadcast networks. In recent years, radio relay points have increased at a rate of 3.5 million a year. The total length of the radio relay network's cable lines comprise about 2 million kilometers.

At the present time, approximately 50 million radio relay points are operating in the cities. The automation of technical processes is being introduced at the municipal broadcasting centers to make the PV system highly profitable as well as significantly reduce its labor intensity.

Standard amplification equipment of the UPV-5 type with 5 kw rated power and the 15 kw UPV-15 are prevalent at the municipal radio relay centers (RTU). The operational reliability of the PV system in the cities is attained through redundancy of the system's most important components.

More than 20 million radio centers are now operating in rural radio relay networks. The feature of radio installation in rural localities is the small number of radio relay points required for each kilometer of line, as well as the prevalence of manual labor. Hence, rural radio relay centers have a low profitability.

The most important task in developing and improving the radio installation industry during the tenth quinquennium is automation of the numerous rural RTU which will sharply improve the technical-economic features of the rural networks.

At the present time, more than 7,000 rural broadcast centers have been automated, thus allowing over 10,000 station operations personnel to be freed.

There are two automated systems for rural RTU. First, the radio channels of MV-CHM stations are used to provide broadcast programs to the radio centers; secondly, this is accomplished through cable channels for rural telephone communications. The automated 500 watt TUPV-0.25x2 transistorized radio center has achieved broad distribution throughout the rural radio relay networks. The TUPV-0.25x2 equipment is installed within the reception zone of MV-CHM stations where the effective field intensity is no less than 50 microvolts/m. A specialized monitoring and backup control apparatus (AKRU) which operates on the rural telephone network is being manufactured to monitor the operation of automated radio centers. The system for automating radio relay centers by using cable channels for supplying broadcast programs and remote signals, and for adopting the AKRU equipment is being distributed to the RTU's which are located outside the positive reception zone of MV-CHM stations, and are also positioned close to operating radio relay and cable lines.

During the tenth quinquennium, new automatic, transistorized amplification equipment of the 1 kw TUPV-0.5x2 model will also be introduced at the RTU's.

The primary thrust for development and improvement of PV during the tenth quinquennium is the potential acceleration for transferring it to a domestic three-program broadcast (TPV) system. This is not only a technical-economic task, but it is also one of socio-political import. At the present time, over 30 million radio relay points within the cities can already provide reception for three-program broadcasts. However, it is necessary to sharply reduce the gap between the radio networks' capabilities and its satiation with the three-program loudspeakers which the radio industry is currently producing in insufficient quantities.

The advancement of TPV into rural localities is an important measure. During the tenth quinquennium, TPV will be introduced here primarily at the automated RTU's which are located within the operating zones of MV-CHM stations.

The greatest achievement of science and technology in the 20th century is television. Television broadcasting is one of the most effective and efficient means of getting information, propaganda and communist training to the working masses. The television transmitter network in our country is the most diversified and one of the most powerful in the world. The total number of television broadcast stations in the USSR at the present time is nearly 2,400.

A branched Central Television network, which since 1967 has begun equipping itself with operational television systems using artificial earth satellites (ISZ), has been organized within the country. As a result, the positive reception zone for

central television programs has been sharply broadened and in 1978 encompassed territory in which 83% of the nation's populace resided.

Central television, as well as radio broadcasting, has gone over to round the clock transmission of television programs. At the present time, the Central Television broadcast out of Moscow is conducted with 7 programs, three of which are transmitted through communications satellites. They are called "Orbita-1", "Orbita-2" and "Orbita-3", and are phase shifted in time. Now residents in the eastern regions of the Soviet Union can watch television transmissions from Moscow at a time convenient for them on the very same day as residents of the capital. To provide Central Television programming transmissions, engineering and technical complexes which are some of the biggest in the world are under construction in Moscow. In the union and autonomous republics, krays and oblast's, aside from Central, there are local television programs with the accompanying audio in the native languages of the people of the USSR.

The most important step in the development and refinement of television broadcasting was the qualitative jump which enabled us to see the world in its natural colors -- the introduction of color television. Routine color television transmissions using the joint Soviet-French SECAM system began in 1967. At the present time, already more than 80% of the Central Television programs are transmitted in color. In the near future, a total transfer by the All-Union Technical Television Center in Moscow to color television equipment is envisaged. The necessary technical foundation for preparing republic and local color television programs in all the capitals of the union republics and many of the major cities of the nation has also been created. Presently, color television transmissions can be received with high quality imaging in more than 800 of our nation's cities and in numerous populous rural communities.

It should also be noted that to handle the Olympic Games which will be held during 1980 in Moscow, alongside the existing All-Union Technical Television Center at Ostankino a new special structure is being built. With its equipment, as well as satellite and ground communications facilities, television and radio broadcasts will be transmitted to foreign countries in as many as 20 television and 100 radio broadcast programs.

A tremendous achievement in scientific and technical progress was the activation of the "Orbita" system which provides Central Television broadcasting to the more remote and inaccessible regions of the country, where by utilizing the customary technical means television would not have arrived for many years. Presently, 80 "Orbita" stations are operating in the country. By the end of the tenth quinquennium, the number of stations in the "Orbita" space system will exceed 90.

An exchange of television programs is underway amongst cities in the Soviet Union on the branched intercity television channel network which has been created, as well as on the "Intervision" network (with socialist nations) and "Eurovision" (with the west European capitalist countries). Through communications satellites, an exchange of television programs with nations located on other continents of the earth is possible.

In the lead article of the 1 March 1978 issue of "PRAVDA" is stated, "Presently, already a major portion of the population of our country receives Central Television's Program I. The time has come for the practical resolution of another important task -- the production and gradual introduction of a second all-union television program." This task will be resolved during the tenth quinquennium. Already many residents in more than 20 oblast's of the RSFSR, as well as in the Ukranian, Belorussian, Latvian, Lithuanian and Estonian SSR's, are now watching two Central Television programs.

This noteworthy technological progress in television was achieved thanks to the development within the Ministry of Communications of the principles and technical programming plans for the television broadcast transmitting networks and the series production by the radio industry of the necessary television sets and equipment. At the present time, new frequency bands are being used for television. In the 48.5 - 230 mhz band, RF television channels 1-12 have been totally freed, and the new decimeter frequency band at 470 - 638 mhz, where television channels 21-41 are located is beginning to be used. During the tenth quinquennium, the introduction of the new, powerful automated meter band television transmission station of the ATRS-5/1 type with a rated power of 5/1 kw will begin operations on television channels 1-12. In place of the "Ladoga" television station, introduction of the new television transmitting station "Il'men'", which is made with klystrons, will begin for the decimetric wave band.

In addition to the powerful television stations, low power television retransmitters are receiving wide distribution. At the present time, a new automatically operated, low power color television retransmitter of the RTSTA-70-R/12 type which is intended to relay color as well as black and white television transmissions is under production. The RTSTA-70-R/12 retransmitter is serially produced in two versions -- first, for installation at intermediated points along radio relay lines, and second, for wireless reception of the powerful television stations with RTU receiving equipment. For operation in the satellite communications system the RTSTA-70-R/12 retransmitter is completed with antenna feed and receiving equipment.

Successes in the development of satellite communications have been noteworthy. Experiments have been completed and operation of the system has begun using the multi-barreled geosynchronous "Raduga" satellite. Now for better television broadcast coverage of our country's territory, satellites of the "Molniya" series, located in high elliptical orbits and the "Raduga" series in circular equatorial orbit, are used jointly.

Since 26 October 1976, tests have begun on a principally new geosynchronous television broadcast satellite "Ekran", which differs from existing satellites by the presence of on board retransmitting equipment with increased power, which provides for the transmission of color or black and white Central Television programs to a network of simplified television receiving facilities of the "Ekran" system which are positioned in the population centers of Siberia and the Far North.

In addition to improved retransmitter equipment on board the satellite, there are a three-axis system for precise earth orientation, a power supply system with solar batteries which independently point at and track the sun, an orbital correction system, a radio telemetry system for transmission of data to the ground concerning the operation of on board systems, and a radio system for the precise measurement of orbital parameters and satellite control. The "Ekran" satellite has an international registration index of "Statsionar-T."

During 1977-1978, 150 ground receiving terminals were equipped for the "Ekran" system. Reception of the television programs is carried out by equipment of the "Ekran" system which is tuned to a frequency modulated signal which is being emitted by the on board retransmitter.

During the tenth quinquennium, the ground technical facilities for television broadcasting will also receive significant growth. Construction is planned for nearly 100 new powerful television stations and more than 1,000 low power retransmitters, including receivers and antenna feed installations for operating within the "Ekran" satellite television broadcasting system.

The development of satellite and ground technical facilities for television broadcasting has created realistic conditions for making significant progress in getting television to the rural communities.

The rapidly developing communications satellite facilities have had a major impact on the national economy. It has provided telephone and telegraph communications to remote regions of the USSR, begun transmission of central newspapers by means of phototelegraphy and has made a decisive contribution to the organization of television in the country, and has practically made it possible in the near time frame to reach the entire territory of the country through television broadcasting.

Our nation is presently proposing the most diversified native communications satellite system which has the largest network of "Orbita" and "Ekran" ground stations in the world. During the tenth quinquennium, in concert with the directives of the 25th KPSS congress, this system will receive even further growth.

Sixty years of development for the communications industry and the vigorous growth which has resulted from Lenin's decrees and the unflagging concern of the communist party are inspiring Soviet radio operators to further labor victories in this third, decisive year of the tenth quinquennium. They are fulfilling with honor their obligations for an early completion and over-fulfillment of the tasks which have been provided by the historic decisions of the 25th KPSS congress.

COPYRIGHT: Izdatel'stvo "Svyaz'", "Vestnik svyazi", 1978

9082
CSO: 1823

PRACTICAL APPLICATIONS OF SOVIET COMSAT SYSTEM

Moscow VESTNIK SVYAZI in Russian No 4, Apr 78 pp 5-7

[Article by V. M. Tsirlin, Candidate for Technical Sciences, and V. P. Dmitriyev, Candidate for Technical Sciences and staff member of NIIR (Scientific Radio Research Institute): "Satellite Communications"]

[Text] Satellite communications offer a brilliant example of a practical application of modern scientific achievement in space research for the needs of the national economy. Within the Soviet Union, communications via artificial earth satellites (ISZ) have long since gone beyond the scope of experimental research and have become a powerful long distance communications medium which provides television broadcasting to our vast territories with a population of many millions. "To provide for the broader utilization of artificial earth satellites primarily to supply television broadcasting to the regions of western and eastern Siberia and for telephone-telegraph communications with remote areas of the country" -- these lines were written in the "Primary Development Trends For the National Economy During 1976 - 1980" and represent the programmed activity of scientists, engineers and technicians in the area of future development and introduction of this newest mode of communications during the tenth quinquennium.

Satellite communications, which originated only recently, are unthinkable without the use of modern day achievements in electronics, especially in the area of reliable and miniaturized components, noise free amplifiers, antenna systems, computers, etc. Actually the power output of a satellite retransmitter is approximately the same as a retransmitter on a radio relay line, although the radio path distance is 1,000 times greater. The difference in signal attenuation must be compensated for by the most complex technology -- large sized antennae, noise free input units, etc.

The efficiency of the satellite systems is based on their high carrying capacity which consists of hundreds and thousands of channels on a single

satellite. Most effective are the satellite systems in transmitting circular information such as television and radio broadcasts, and newspaper pages. This is explained by the fact that the satellite is the more expensive element of the system, is used simultaneously by all the stations which are receiving the very same information, and therefore its cost is divided amongst all the communications routes. Therefore, the transmission of circular traffic is the most important function of satellite communications.

Satellite systems can be economical in the transmission of telephone-telegraphic traffic if the communications are carried out over great distances. Considering that the cost of a satellite channel is independent of its length (in contrast to a ground channel), satellite telephone lines become comparable in cost with highly efficient ground cable and radio relay lines when the communications distance exceeds 1,000 - 5,000 kilometers. Future improvement in the satellite systems will allow them to become economically efficient over lesser communications distances.

The television distribution networks have achieved greatest growth and dissemination. The "Orbita" ground station network, which has been operating since 1967 through the "Molniya" satellites, has provided for the reception of television programs at more than 70 locations. The "Orbita" stations are presently operating within three different networks providing zonal television (TV) broadcasting (the programs of "Orbita I, II and III with time shifts of 9, 6 and 3 hours relative to Moscow time). At the present time, these networks are being serviced correspondingly by "Molniya-3" satellites in elliptical orbit and two "Raduga" ISZ located in geosynchronous orbit.

Special stations were created to bring television broadcasting to the people living in the less populated areas, and in 1976 a trial run was introduced for the "Ekran" television broadcast system which consists of satellites in geosynchronous orbit and a network of a new type of ground receiving stations operating in the 700 mhz band.

The frequency modulated signal of the ground transmitter (the program source) is retransmitted by the spaceborne station's phased array antenna. The equipment for two types of ground stations is designed for high quality reception (figures 1 - 3). The received signal proceeds to the television retransmitter which services the local television receiving network. The number of "Ekran" receiving stations is already approaching 150, and by 1980 their number will exceed 1,000.

Future development of the television broadcast receiving system is being directed towards creating a system in the 12 ghz band.

During the Olympic Games, 20 different TV programs will be transmitted from Moscow throughout the entire world. The majority of them are intended mainly for countries on other continents and will be disseminated through satellite systems.

The advantages of satellite systems for providing transmission of circular information apply in equal measure to the supplying of radio broadcast pro-

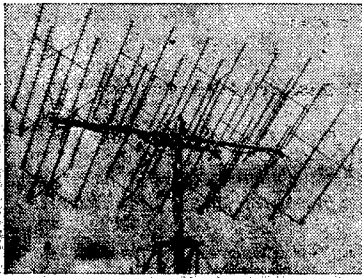

Fig. 1 - Receiving antenna for the "Ekran" system

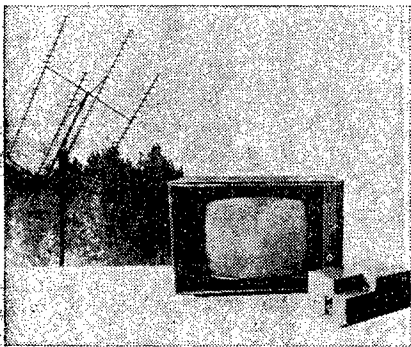

Fig. 3 - Type PA receiving installation for the "Ekran" system

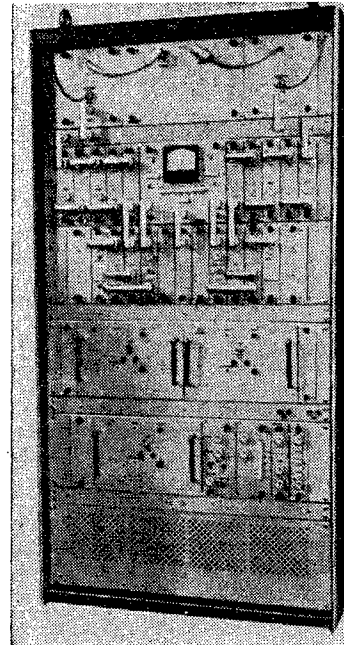

Fig. 2 - Type PP receiving installation for the "Ekran" system

grams to local radio centers and to the transmission of newspaper pages for printing in regional publishing houses. With this objective, the systems for supplying radio broadcast programs and transmitting newspaper pages simultaneously with television on a carrier frequency of 7.5 mhz were developed and are being used. The class I radio broadcast signal has a frequency band width of 50 - 10,000 hz, while a newspaper transmission signal ranges from 50 - 60,000 hz.

The "Mayak" program is presently being transmitted to 150 stations and by 1980 their number [will encompass] the nation. The transmission of newspapers to the city of Khabarovsk allows subscribers in the Far East to receive 10 central newspapers on the day of their publication.

In addition to television reception, the "Orbita" stations are used for satellite telephone-telegraph communications. A new generation of receiving and transmitting equipment is under development using modern components for providing high reliability, the capability of operating in any trunk line, etc.

The specific task in creating telephone-telegraph communications systems is providing multi-station access, i.e., the operation of many stations through a common relay trunk without mutual interference. Originally, frequency

access systems were introduced in which separate carriers were used for each station. These systems are simpler, but their capacity is degraded because of transient interference. With time access, at each moment in time only a single signal is being transmitted through the retransmitter and the retransmitters capacity is increased by 2 - 3 times. However, time access requires more complex channel formation equipment and an increase of power by the ground transmitter. Both principles are used in existing systems -- frequency access for low-channel communications stations with small amounts of traffic, and time access for stations with requirements exceeding 24 channels.

A distinguishing characteristic of the telephone transmission system mentioned is the use of the modern digital transmission techniques KIM-DFT (pulse-coded modulation and two-stage phase telegraph), which permit optimal usage of a satellite trunk's capacity. With time access, digital transmission provides a capacity of 600 telephone channels to a trunk line, and with frequency access only 200 - 400 channels.

The significance of creating communications satellite systems is great not only of our nation, but also for numerous other countries of the world which have the capability to conduct communications over tremendous distances through ISZ.

In the interests of international cooperation, back in 1971 the "Intersputnik" communications satellite system was created (membership includes Bulgaria, Hungary, GDR, Cuba, Mongolia, Poland, Rumania, USSR, and Czechoslovakia). This system is used for the transmission of television with accompanying sound and for telephone-telegraph communications.

COPYRIGHT: Izdatel'stvo "Svyaz'", "Vestnik svyazi", 1978

9082
CSO: 1823

USSR

BRIEFS

NEW TELEVISION, RADIO STATION--In the maritime town of Dalnerechensk, a radio-television station has been rebuilt. It has been equipped with up-to-date Soviet apparatus and a new 250 meter antenna tower has been built. As a result, the power of the station has increased tens of times insuring stable reception of television broadcasts from Moscow and Vladivostok and providing pictures for the remote villages of the Kray. [Moscow Domestic Service in Russian 1400 GMT 17 May 78 LD]

CSO: 5500

PTT'S 1976 ACTIVITIES, FINANCES REVIEWED

Paris REVUE DES PTT DE FRANCE in French No 1, 1978 pp 49-61

[Text] The Secretariat of State for Telecommunications has just published its activities report for the year 1976. The limited number of copies printed of this brochure leads us each year to publish excerpts on the most significant activities of our department.

Our readers will recall the modernizing and equipping efforts made over the past 3 years in the field of telecommunications and to a different extent in the postal sphere. It is appropriate to endow France with a telephone network responding to the requirements of the modern world and to adapt the postal service better to the needs of private individuals and enterprises.

Nineteen seventy-six was an exceptional stage in the realization of this major plan. The government decided to give first priority to our country's telephone equipment and to pursue these efforts throughout the Seventh Development Plan. The 1976-1980 action program provides for the installation of 8 million new main lines and steady improvement in the quality of service, whether it be a matter of subscribers' lines or of communications, the average time lag for installation is to be reduced to 3 months.

As for the postal service, priority has been given on a national basis to the automation of operations. The launching of 49 new building plans and the acquisition of 128 machines for sorting letters and parcels in the course of the next few years will speed up modernization of the routing network and improvement of the establishments' productivity and of the postal employees' working conditions.

The other commitments concern the presence and quality of the postal service. In urban areas the establishment and construction of a greater number of offices are intended to bring the post office "windows" closer to the consumers and to reduce the size of the establishments; in the rural areas, the administrative presence will be maintained and gradually diversified and improved.

POSTAL TRAFFIC

Categories of items (in millions of items)	1975*	1976*	Variations 1976/1975 (in %)
Paid traffic			
Letters up to 20 gms and special delivery postcards.....	3,576.6	3,610.6	+ 0.95
Letters over 20 gms.....	453.4	447.63	- 1.27
Registered letters.....	88.0	88.9	+ 1.04
Ordinary letters at regular rates..	1,775.1	2,009.3	+13.19
Ordinary letters at special rates**	1,067.1	1,056.8	- 0.97
Periodicals.....	2,195.0	2,186.1	- 0.4
Ordinary nonurgent parcels.....	174.4	179.2	+ 2.75
Ordinary special delivery parcels..	41.2	40.24	- 2.33
Registered parcels.....	38.6	39.7	+ 2.85
Items of declared value.....	2.9	3.03	+ 4.48
Total.....	9,410.3	9,659.50	+ 2.65
Official and franked mail			
Ordinary letters up to 20 gms.....	1,756.9	1,831.4	+ 4.24
Ordinary letters over 20 gms.....	175.6	197.04	+12.21
Ordinary parcels.....	25.3	37.8	+ 9.88
Insured and registered mail.....	58.1	62.47	+ 7.52
Total.....	2,015.9	2,118.71	+ 5.1

*Including overseas departments

**Not including printed matter or catalogues not addressed to specific individuals: 506.7 million in 1976

Traffic

The traffic, which increased by 3.08 percent as opposed to that of 1975 may be estimated at 12.3 million items carried.

Delivery

Motorization and Centralization of Postal Delivery to Addressees

In 1976, 731 motorized rounds (340 urban and 391 rural) and 12 motorized distribution centers were put into service.

Delivery of Telegrams

The reduction in the traffic of telegrams recorded in 1975 persisted in 1976. Thus the annual traffic of telegrams, notification of calls and "pneumatiques" [express letters transmitted in Paris area by pneumatic tubes] decreased from 18,250,000 items delivered in 1975 to 16,500,000 in 1976.

On the other hand, that of special delivery mail remained stable, that is, a little over 13 million items.

In addition, the number of vehicles available remained virtually the same as in 1975, that is, 1,900.

CIDEX [expansion unknown]

In 1976, 75,000 boxes were installed. This brings the total number to 510,000.

Motorized Delivery Rounds for the 1967-1976 Period

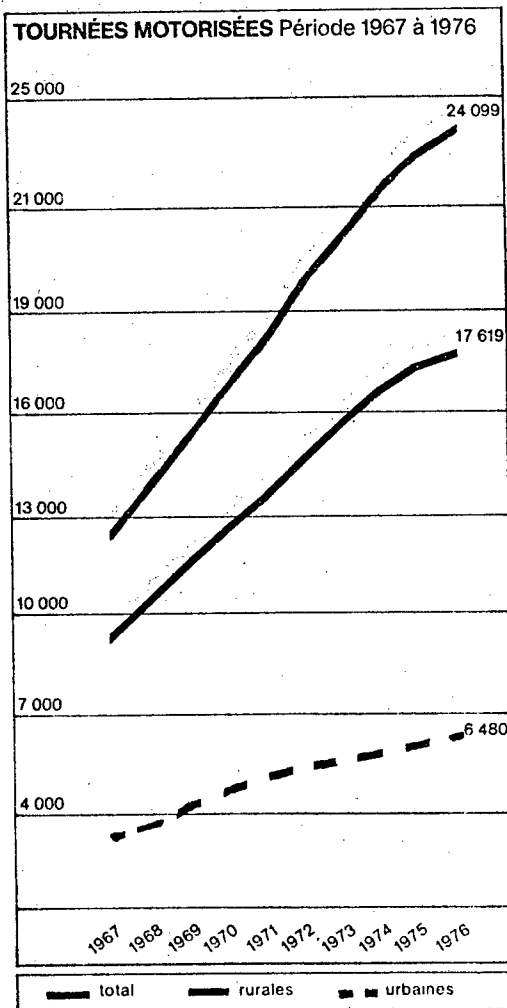

Postal Service

Postal Transport

Air Transport

By 31 December 1976 the air mail fleet consisted of 15 F-27 Fokkers and four C-160 Transalls. Within the framework of the action plan aimed at improving the quality of the routing service, the agency had a study made to reorganize the air mail postal network which at the present time includes 20 stops.

Growth of Air Mail Activities

Year	Number of Tons Carried	Number of Kilometers Covered	Number of Flying Hours
1974	38,928	4,503,156	16,282
1975	42,750	4,859,203	17,142
1976	45,920	4,849,189	16,987

Rail Transport

The administration has sought out autonomous means of transport responsive to the concern for rapid connections between the towns that are the headquarters of automatic sorting centers. With this in mind, mail trains were put into service in September 1976 on the Paris-Bordeaux, Paris-Toulouse and Paris-Lille lines.

Within the framework of modernizing the sorting and routing services, it was decided to acquire multiple unit Diesel trains. Two of them will be in use by the end of 1978 on the Paris-Caen run.

The putting into service of 59 new 26.50 meter long postal service cars in 1976 must also be noted.

Road Transport

In 1976, 43 new connecting roads built under contract were provided. In addition, parcel post shipments in containers of the new Container Company were extended to 18 connecting points between the parcel handling centers.

Growth of Rail Transport Activities

Year	Railway mail cars and tenders (millions of TKBR*)	Vans (millions of TKBR)	Number of kilometers covered by mail cars (in thousands)
1972	1,758	710	40,707
1973	1,785	796	41,221
1974	1,732	750	36,602
1975	1,988	826	45,265
1976	2,036	852	45,930

*Gross kilometric tons hauled

Growth of Road Transport Activities (Connecting Transport under Contract)

Year	Number of Services	Number of Kilometers Covered (thousands)
1972	1,669	64,174
1973	1,716	67,278
1974	1,728	70,106
1975	2,055	80,937
1976	2,098	82,929

Dead Letter Office

In 1976 the dead letter office received 6,151,205 items of all types as opposed to 7,105,876 the previous year. Of these it was possible to deliver 2,600,519 of them to those entitled to them before claims were initiated.

POSTADEX [expansion unknown]

At the national level, 177 new Postadex liaison points were established in 1976 raising the total number of internal liaison points to 786. In addition, the regional Postadex was increased by 45 new liaison points.

Financial Services

Post Office [Bank] Accounts

The increase in traffic noted in 1976 (+3.6 percent) was accompanied on the part of the post office accounts by an over-all growth in deposits payable on demand (16.1 percent as opposed to 15.8 percent in 1975) and in the number of accounts. Thus, on 31 December 1976, the number of current accounts came to 7,225,000 as compared with 7,165,000 in 1975, or +0.8 percent. The total

amount of operations (4,916 billion francs) increased by only 12 percent in contrast to 30 percent in 1975.

Financial Services' Activities

Types of Operations	Volume of Traffic in 1976	Percentage of Change 1976/1975
<hr/> Post Office Checking Accounts		
Current accounts as of 31 December.....	7,225,000	+ 0.8
Total assets of all accounts (in billions of francs).....	57.3	+ 5.3
Total number of operations (in millions).....	1,690	+ 3.5
Total amount of operations (in billions of francs).....	4,916	+12
<hr/> Postal Savings Bank		
A and B pass books' assets on 1 January 1977 taking into account capitalized interest (5,667 million francs) in millions of francs.....	100,488	+18.6
<hr/> Home Savings		
Number of pass book accounts.....	128,085	+10
Assets (in millions of francs).....	1,977	+27
Number of plans.....	158,842	+20
Assets (in millions of francs).....	2,726	+43
<hr/> Postal Money Orders		
Money orders issued (internal system) in millions of units.....	232.9	+ 4.9

Post Office Checking Accounts--Monetary assets in France (as of 31 December) in millions of francs*

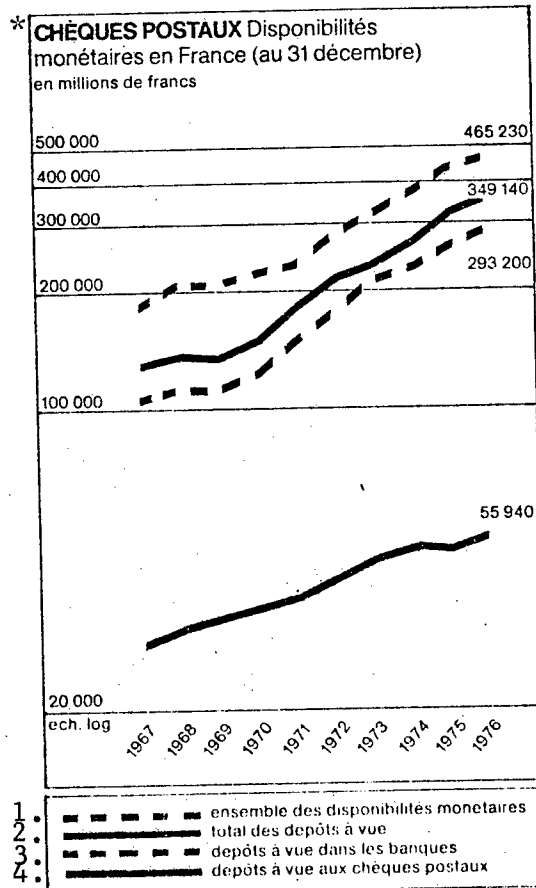

1. Total monetary assets available
2. Total deposits payable on demand
3. Bank deposits payable on demand
4. Postal Savings Bank deposits payable on demand

Post Office Bank Accounts

The increase in traffic noted in 1976 (+3.6 percent) was accompanied on the part of the post office bank accounts by an over-all growth in deposits payable on demand (16.1 percent as compared with 15.8 percent in 1975) and in the number of accounts. Thus, on 31 December 1976, the number of current accounts numbered 7,225,000 as opposed to 7,165,000 in 1975, or +0.8 percent. The total amount of operations (4,916 billion francs) increased by only 12 percent in contrast to 30 percent in 1975.

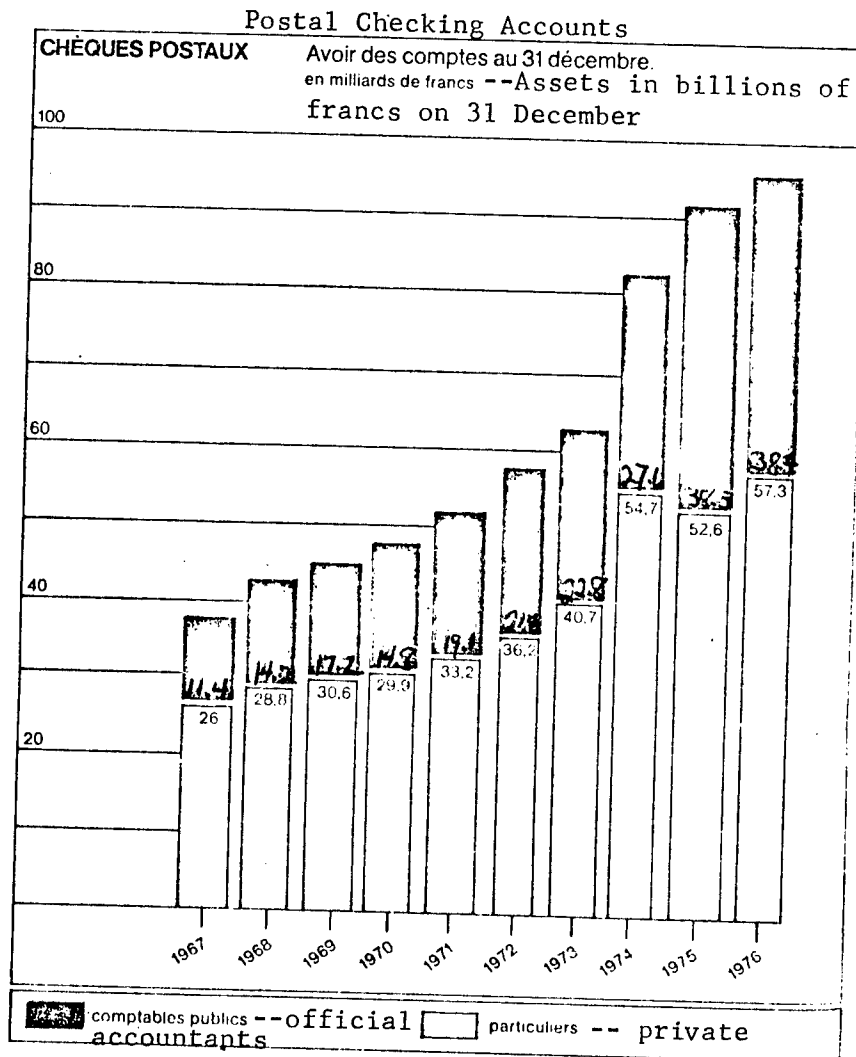

CNE

The CNE's [Postal Savings Bank] activities remained at a very constant level even though the rate at which traffic increased was lower than during the preceding year: 16 percent as opposed to 23 percent.

Ordinary Savings

Beginning 1 January 1976:

The interest rate paid on A and B pass books was reduced from 7.5 percent to 6.5 percent.

Maximum deposits allowed A pass books rose from 25,000 francs to 32,500 francs.

In addition, taking capitalized interest into account, by 1 January 1977 the assets of A and B pass books had risen to 100,488 million francs, i.e., an increase of 18.6 percent as compared with the previous year.

Home Savings Accounts

Effective 17 March 1976:

The maximum amount for pass book and plan deposits was increased to 100,000 francs (an amount that may be exceeded by capitalizing interest) and that of principal and complementary loans to 150,000 francs each;

The savings premium ceiling was raised from 5,200 to 7,500 francs for pass books and from 6,750 francs to 10,000 francs for plans.

Postal Savings Bank

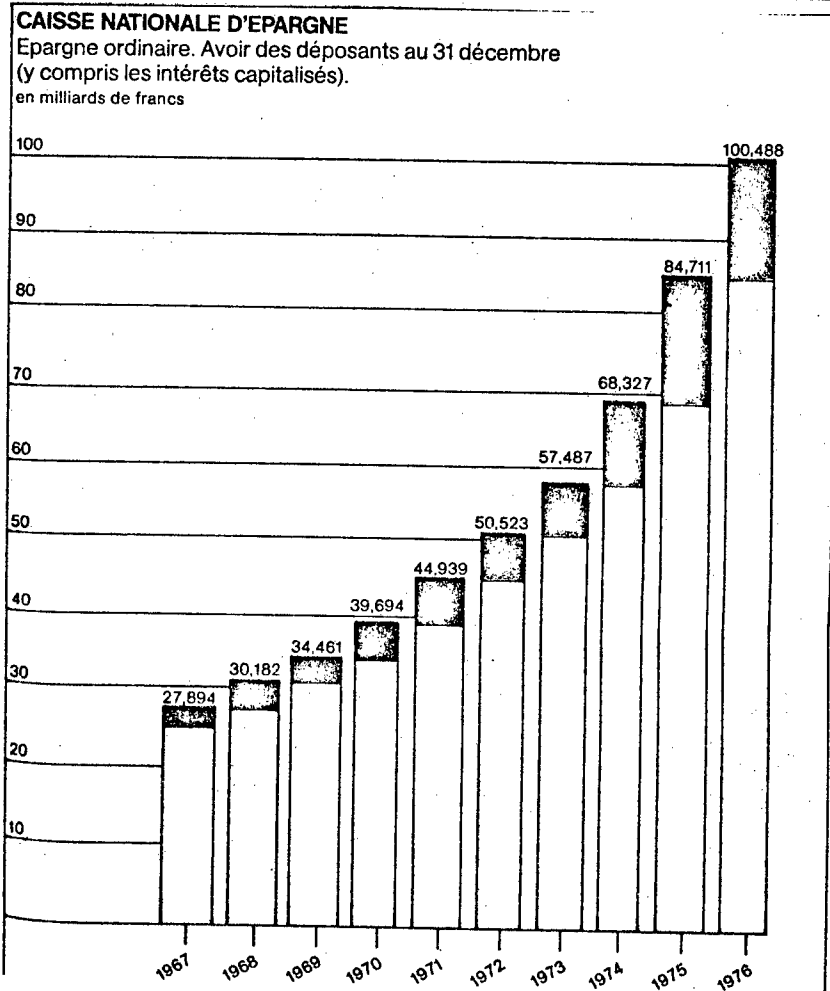

*Ordinary savings. Depositors' assets as of 31 December (including capitalized interest). In billions of francs.

Postal Savings Bank

Ordinary savings' cumulative surplus of deposits versus withdrawals (in billions of francs)

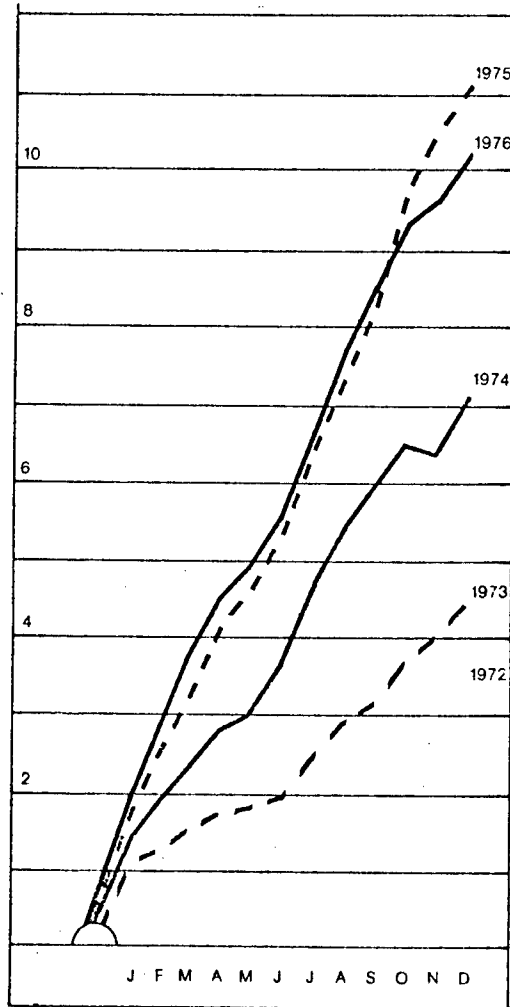

Various Financial Services

Treasury Bonds

During 1976, 4.2 million treasury bonds (+4.3 percent in comparison with 1975) were issued by the PTT cashiers in the amount of 7.6 billion francs.

Again in 1976, 2.6 million shares (-29.4 percent) were redeemed in the amount of 4.1 billion francs (-22.9 percent).

The increase in transactions was attributable to the issuance of bonds with gradually mounting interest rates.

Loans

Two PTT loans were issued in April and November 1976.

The PTT's cashiers also took in 1,548 million francs in subscriptions out of an over-all total of 1,749 million francs.

Equipment

Buildings

As of 31 December 1976 the number of business premises "managed" by the postal and financial divisions came to 16,490 of which 4,208 state-owned and comparable business premises and 12,282 premises rented or provided rent free.

Program permits for 1976 amounted to 310 million francs for post office buildings, administrative offices and warehouses, and to 202.5 million francs for the implementation of the mail sorting centers building program. [See p 12]

Transport

As of 1 January 1976 and 31 December 1976, the inventory of vehicles available to the postal and financial divisions consisted of the following

	No of Vehicles 1 January 1976	Growth in 1976	No of Vehicles 31 December 1976	Percentage 1976/1975
Light vans	26,568	+ 890	27,458	
Other vehicles	3,528	+ 300	3,828	
Total No of Cars*	30,096	+1,190	31,286*	+3.95
Motorcycles**	4,253	+ 230	4,483**	+5.40
Trailers	17		17	-

*Including 29,417 light vehicles of which 27,288 light vans assigned to the delivery and collection of mail, 1,899 vehicles for carrying telegrams and postmen, 68 vehicles for personnel transport (connecting vehicles and buses) and 17 traveling post offices.

**Intended particularly for the telegram delivery service.

As for the program permits granted under the financial law of 1976, they are as follows:

Equipment Sectors	Program Permits 1975 (millions of francs)	Program Permits Granted for 1976 (millions of francs)	Percentage 1976/1975	
Road materiel:				
Vehicle replacements.....	56	78.0	+ 39	
Service equipment.....	6	14.5	+140	
Total.....	62	92.5	+ 49	
Railway and transshipment materiel.....	58.40	62.00	+ 6	
Equipment for garage workshops.....	4.70	5.00	+ 6	
<hr/>				
Building Operations Carried out by PTT Directorate General	1975		1976	
	Number	M ² Usable Surface	Number	M ² Usable Surface
Building Work Begun During the Year				
Construction.....	72	200,274	68	223,361
Extensions-floors added....	18	11,766	21	9,496
Improvements.....	66	13,721	118	17,072
Total	156 (-14.29%)	225,761 (+33.29%)	207 (+32.69%)	243,929 (+10.71%)
<hr/>				
Work completed during the year				
Construction.....	83	110,844	85	265,773
Extensions-floors added....	21	10,437	15	8,688
Improvements.....	70	15,387	87	19,047
Total	174 (-4.92%)	136,668 (-15.36%)	187 (+7.47%)	293,488 (+114.75%)
<hr/>				
Work Under Way as of 31 December 1976				
Construction.....	91	299,467	74	274,035
Extensions-floors added....	22	22,845	29	23,156
Improvements.....	42	21,239	71	11,974
Total	155 (-13.89%)	343,551 (+33.17%)	174 (+12.26%)	309,165 (-10.01%)

Telecommunications

Telecommunication activities in 1976 can be characterized by two facets:

Continued efforts to improve the quality of service, especially in the areas of the flow of traffic and automation of the service provided telephone subscribers;

Speeding up of the rate at which [new] subscribers' telephones are connected.

Traffic

Domestic and international traffic increased by 15.4 percent in contrast to 13.3 percent in 1975.

As for Telex traffic (domestic and international), it rose by 10.7 percent as opposed to 7 percent in 1975.

Telephones--Rate of Automation by Regions (in percentages)

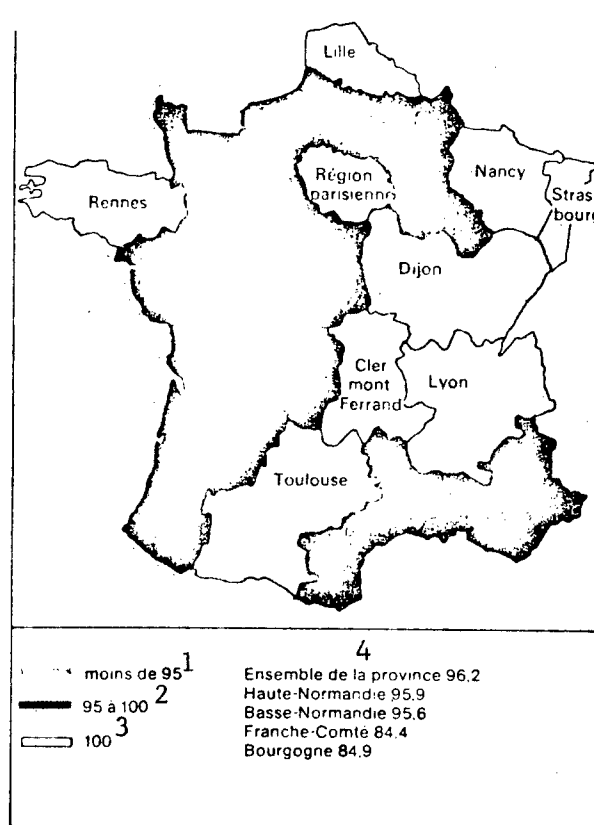

1. Less than 95
2. 95 to 100
3. 100

4. Provinces as a whole: 96.2
- Upper Normandy: 95.9
- Lower Normandy: 95.6
- Franche-Comte: 86.4
- Burgundy: 84.9

Telecommunications Summed Up in a Few Figures*

Telephones

All types of telephones (as of 31/12/76).....	15,656,000
Principal subscriptions (as of 31/12/76).....	8,270,000
Automation rate (as of 31/12/76).....	97.4
Principal lines connected in 1976 (new subscribers and transfers).....	1,716,000
Over-all applications for principal lines received in 1976 (net amount).....	1,986,000
Total outgoing traffic (in millions of basic charges) in 1976.....	33,987

Telex

Private subscriptions (as of 31/12/76).....	60,996
Total outgoing traffic (in thousands of communications in 1976).....	83,042

Telegrams

Outgoing telegrams (in thousands):	
Domestic.....	12,404
International	3,599

Teledata Processing

Number of terminals installed (as of 31/12/76).....	30,291
---	--------

*France itself, overseas departments and territories

On the other hand, in comparison with 1975, telegraphic traffic recorded a reduction in the international sphere and stagnation in the domestic sphere.

Teledata Processing

During 1976 it stabilized its growth rate at about 33 percent, the number of terminal installations increasing from 23,300 at the end of 1975 to 30,921. The increase in its specific services should be especially noted:

The Caducee [Caduceus] network had 1,034 subscribers at the end of 1976 as opposed to 800 in 1975;

The Transplex service attained its goal: 320 channels leased as compared with 151 in 1975;

High output transmission connections rose with the opening of the network converted to 2,400 bits/s.

Telephones--Automation Growth Rate of Principal Telephone Lines (as of 31/12/76) in percentages

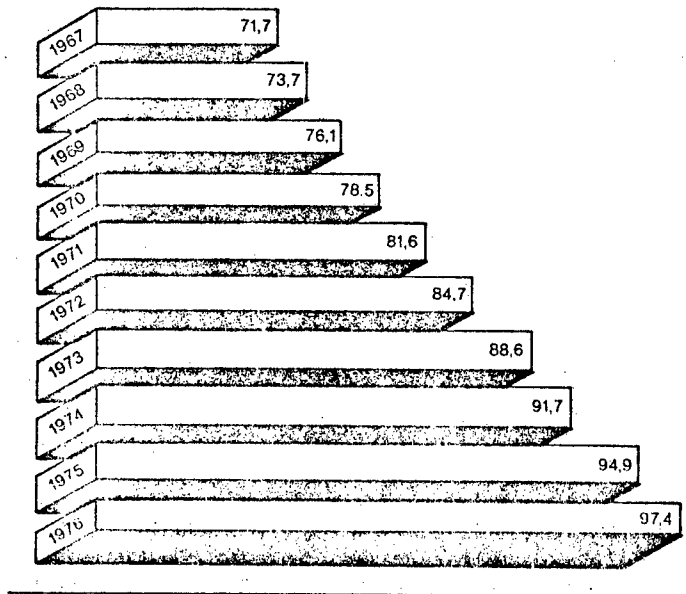

Commercial Activities

During the year 23 agencies were established raising their number to 109 by 31 December 1976.

In addition, the first "teledata processing shops" were opened.

Telephones--Density of principal telephone subscriptions per 100 inhabitants

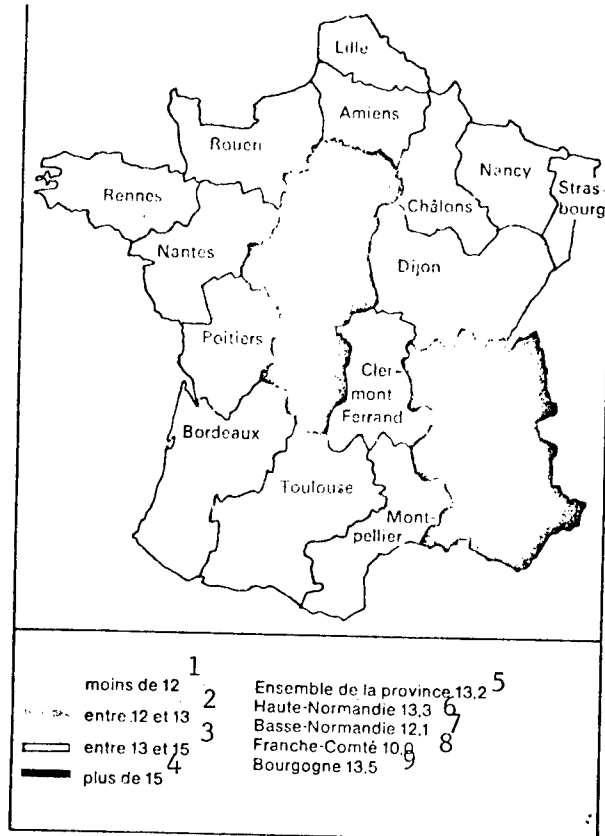

- | | |
|----------------------|-------------------------------|
| 1. Less than 12 | 5. Provinces as a whole: 13.2 |
| 2. Between 12 and 13 | 6. Upper Normandy: 13.3 |
| 3. Over 15 | 7. Lower Normandy: 12.1 |
| | 8. Franche-Comte: 10.0 |
| | 9. Burgundy: 13.5 |

Telephone
Increase from 1967 to 31 December 1976
in thousands

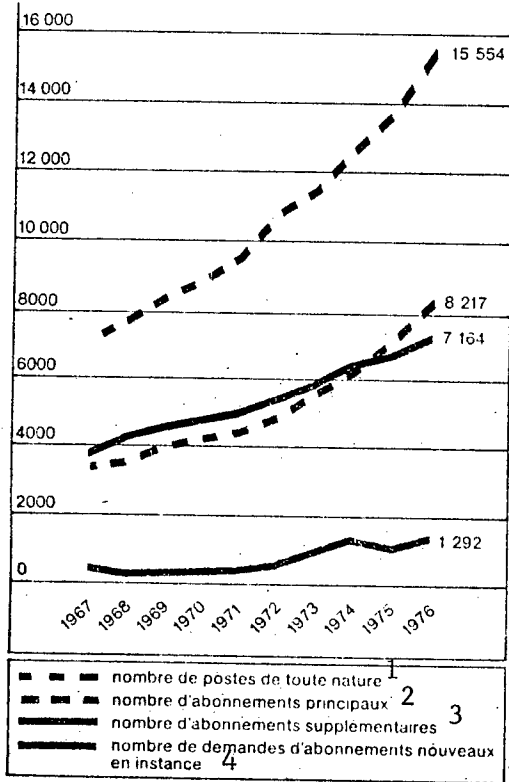

Telephone
Increase from 1967 to 1976 of
total proceeds from outgoing
traffic (expressed in millions
of basic rates)

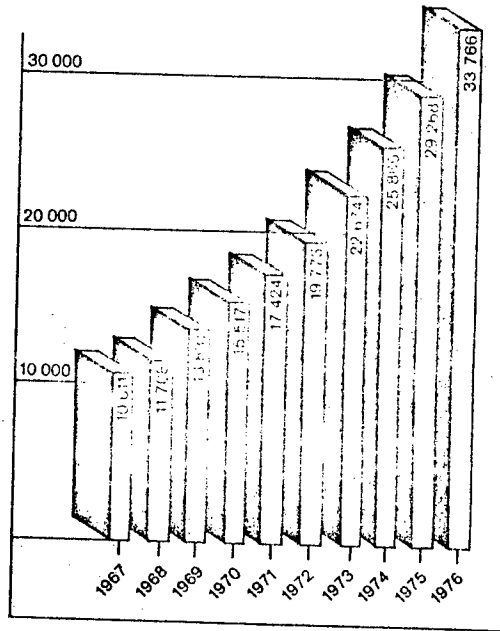

1. Number of telephones of every kind
2. Number of principal subscriptions
3. Number of supplementary subscriptions
4. Number of applications for new subscriptions in process

Over-All Accounts

Analysis of Accounts

The PTT enterprise's turnover for 1976 increased by 21.4 percent by comparison with the preceding year. Operational proceeds were affected by the general situation of the French economy and if expansion remained fairly strong during the first 6 months, circumstances became less favorable in the course of the second 6 months.

Operational proceeds amounting to 2,089 million appear to be clearly more favorable from the over-all standpoint than those obtained in 1975 (+778 million), but they mask the differences exposed by a sectorial presentation. The mails recorded losses both in their postal activities (491 million) and in their financial operations (1,393 million), while telecommunications showed profits never previously attained of 3,973 million francs.

As for equipment, it was telecommunications which had a more sizable budget at their disposal; they were provided 9.8 billion from budgetary credits and 4.9 billion from the various financing firms, the most recently created, Francetel, contributing on its own at the level of 2.4 billion francs.

The value of capitalized holdings when amortizement and depreciation are taken into account exceed the figure of 53.6 billion francs as compared with 41.6 billion at the end of 1975, that is, an increase of nearly 30 percent. As for stock, it comes close to 4 billion francs.

Finally, the PTT's primary role in the banking sphere must be emphasized. The clientele of post office accounts numbers 7,225,000 holders and their 95 billion franc assets include the assets of the public accountants (38.4 billion) and those of other holders (57.3 billion) on the basis of which are calculated the payments disbursed by the treasury to the PTT management for utilization of the funds on deposit. The postal savings bank had 14,997,600 accounts and recorded deposits on the order of 105 billion francs.

Operations

Receipts

Total proceeds came to 45,960 million francs and included the operational returns stricto sensu whose growth was a result of the increase in traffic, moderate with respect to the postal and financial divisions and higher where telecommunications and rate readjustments were concerned. They also included the financial returns, the greater part of which derived from the revenue of the CNE's portfolio and from the interest paid by the treasury for the funds placed at its disposal by the postal banking service. Finally, the services which the three main divisions rendered each other amounted to 3,798 million and represented the post office's costs for routing all the mail entrusted to it, the issuing and paying of money orders, telephone and telegraph operations.

...

Expenditures

These came to 43,871.3 million francs; the increase as compared with 1975 was 17.4 percent and less than the increased percentage of receipts which amounted to 18.9 percent.

For their part, personnel costs (20,616.2 million) made up the major operational expenditures: 47 percent.

In relation to the previous year's operations, the increase of nearly 3 billion was attributable to the successive wage increases, the addition for the full year of jobs created in 1975 and new jobs approved in 1976.

The other categories of major expenditures were, respectively:

The financial outlay made up in part of the sums paid out to financing firms, the interest on and costs of loans, and the balance of the interest paid out to the CNE's depositors;

Amortizement which is naturally related to investment efforts;

and though not affecting the balance of the working account since it is made to agree with the proceeds, the providing of official interoffice delivery service.

Capital Transactions

The accounting of capital transactions brings out the major variations affecting the agency's holdings before their transfer to the credit and debit sides of the balance sheet; amounting to 15,765 million, they declined by nearly 600 million as compared with 1975.

Employment

Outside of the investments realized through budgetary credits, the sum of which exceeded 11,200 million francs (purchases of technical materiel representing 8,142 million), it is appropriate to mention the repayment of loans (577 million) and the advances made by public organizations (464 million) and the increase in stock on hand (460 million), raising the total value of the materiel stored in the regional and departmental warehouses and those of the special services to 3,998.2 million francs.

The equipment placed at the disposal of the PTT by the financing firms are not included in the investments appearing on the capital working account; it is nevertheless entered on the balance sheet; on the credit side the means are recorded, and on the debit side the entire long-term debt:

Resources

From an analysis of the financing of capital expenditures, it is evident that the capital acquired by the agency on a permanent basis amounted to 6,762.4 million taking into account various equalization entries whereas borrowed capital came to 6,220 million francs.

Basic funds consist mainly of the operational surplus allocated to investments, 2,058.6 million, of the amortization annuity in the amount of 3,885.8 million, of reserves: depreciation of the CNE's portfolio, the value added tax on leasing operations.

External capital was secured from two public loans of 956.2 and 792.4 million issued in April and November 1976 and mainly through borrowing from the National Telecommunications Fund:

The balance of the 1975 loan;

900 million secured from the domestic market;

2,664.2 million obtained from the international market.

The Balance Sheet

Presented in the form recommended by the general accounting plan, the PTT management's balance sheet now comes to 271 billion and covers the holdings and over-all resources placed at the "enterprise's" disposal to fulfill its mission. Fixed assets in service are separated from those being realized and, moreover, the equipment owned by the five financing firms have been included.

Assets

The continued investment efforts especially noted in the telecommunications sector have led to an unprecedented increase in the total amount of fixed assets in that their gross amount comes to 86 billion francs; the amortization rate is 37.6 percent and attests to the holdings' relatively long-lasting nature.

The equipment provided by the financing establishments amounts to 14.7 billion francs.

The activities of the financial services and more especially the management of the postal bank accounts and the CNE have meant a perceptible increase in available funds which amount to 212.3 billion francs.

Not taking into account the assets of the PTT's cashiers on deposit, the total of the sums entered into the post office's current bank accounts comes to 71.5 billion and is mainly to be found in the treasury's current account (65 billion) and in cash (2.9 billion).

Proceeds and Operating Expenditures
(in millions of francs)

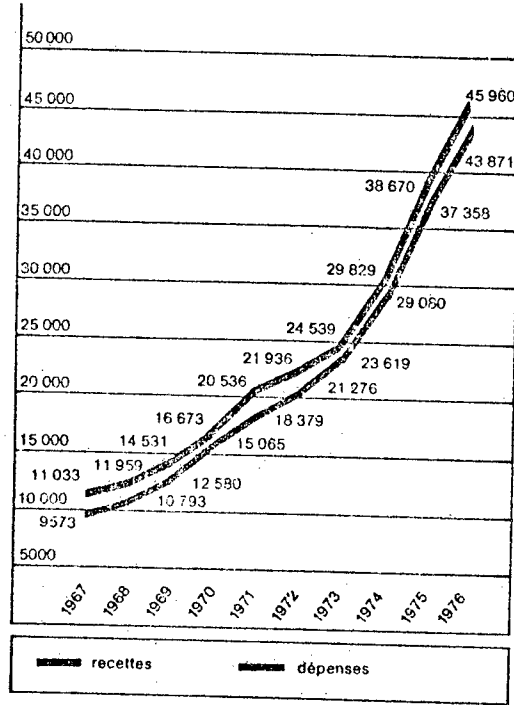

(Amounts expressed in millions of francs)

Debit

Capital assets	
Buildings	5.4
Technical materiel	4,912.6
Work project advances	200.0
Total	5,118.0

Credit

Repayable on long-term basis

	Tax Excluded	VAT	Total
Finextel	377.4	49.3	426.7
Codetel	508.1	61.6	570.7
Agritel	547.9	120.1	668.0
Creditel	571.0	76.6	646.6
Francetel	2,432.1	--	2,432.1
Discharge of advances			373.9
Total			5,118.0

The CNE's depositors' assets added to the capitalized interest come to 105 billion which have as counterpart the stocks and bonds on deposit with the CDC [Court of Accounts] and the returns receivable from accrued, not forfeited interest.

Finally, it is appropriate to note the reserves derived from the value added tax relating to the leasing operations, the growth of this category being tied in with the total amount of the PTT's commitments vis-a-vis the five existing firms.

Liabilities

Standing capital having made the investment financing possible is broken down into wholly owned capital, 17.4 billion, and outside capital, 43.2 billion.

The increase in outside capital is attributable to the new PTT loans issued to the public in 1976, 1,748.6 million, raising "repayment on a long-term basis" to 11 billion francs.

The activities of the National Telecommunications Fund are directly linked to investment efforts and since its establishment 57 loans have been floated (28 new loans during the past fiscal year). The debt amounts to 13 billion francs.

Finally, the commitments to the financing firms come to 14.7 billion francs.

As for repayments on a short-term basis, the current post office accounts' assets, 94 billion (the average increase is 5.7 percent), and those of the CNE's depositors, 105.2 billion, though lower than that seen in 1975 (24.7 percent), the increase of nearly 20 percent has as can be noted, remained very active.

The Accounts by Branches

A study of the PTT management's proceeds and expenditures as a whole does not make it possible to assess the actual results of postal, financial and telecommunication activities. The commentaries accompanying the data given below in figures tend to define them better in relation to the over-all enterprise or to one or another sector of activity.

The Postal Service

The returns from its operations have recorded an increase of 1,953.4 million and amount to 14,585.4 million francs; compared with the agency's receipts as a whole, the postal service's share represents 31.7 percent. The increase in rates which became effective on 2 August swelled receipts in a moderate way because of the slowing down of industrial and commercial activities.

Postal expenditures were 15,076.1 million and wage costs 11,717.4 million francs, respectively. Personnel costs, in comparison with the previous fiscal year, increased by 1,692.4 million and represented nearly 78 percent of costs while the share of wages was 47 percent of the PTT's entire expenditures.

Operational yields boiled down to a debit balance of 490.8 million, a deficit rising to 530.9 million taking into account the operations going back to previous fiscal years or those of an exceptional nature.

Financial Services

Operational receipts amounted to 10,366 million as opposed to 8,995.5 in 1975 and this increase was attributable to the growth of financial proceeds. In reality, the average returns from funds on deposit in current postal bank accounts rose to 4.19 percent whereas they were 3.56 percent during the previous fiscal year, and the investment of funds entrusted to the CNE came to 6,808 million francs exceeding by 647 million the returns estimated at the time the budget was drawn up.

Costs amounted to 11,759.2 million as opposed to 10,430.1 million in 1975 and were the result of the increase in financial costs (interest paid out to the CNE's depositors), the furnishing of services by the PTT and personnel costs.

A new operational deficit of 1,393.2 million was recorded adding to those registered every year since 1966. The increase since 1977 in profits from funds on deposit in the current postal bank accounts should make it possible to improve the financial situation of this branch.

Telecommunications

Telecommunications' share in the operational receipts as a whole was preponderant; the postal service brought in 31.7 percent, the financial services 22.6 percent.

Operational proceeds alone amounted to 19,403.8 million francs and telephone charges (17,227 million) mounted steadily because of the increase in the number of lines and the rise in traffic per subscriber.

Among the expenditures which came to 17,035.9 million, personnel costs remained the largest component (7,128.3 million), but it is obvious that the almost total automation of the technical services is tending to reduce the increase in costs of this nature. Amortizement took second place amounting to 3,492.1 million francs and representing the normal expenses of replacing the materiel in service.

The surplus of the returns recorded in 1976 (3,957.3 million) differed only slightly from that noted in 1975 and makes rather substantial self-financing possible. In fact, it will be seen that resorting to outside capital came to only 4,471 million whereas the cash flow (i.e., the surplus of receipts added to the amortizing) was 7,450 million francs.

Commercial Profits Per Branch of Operations (in millions of francs)

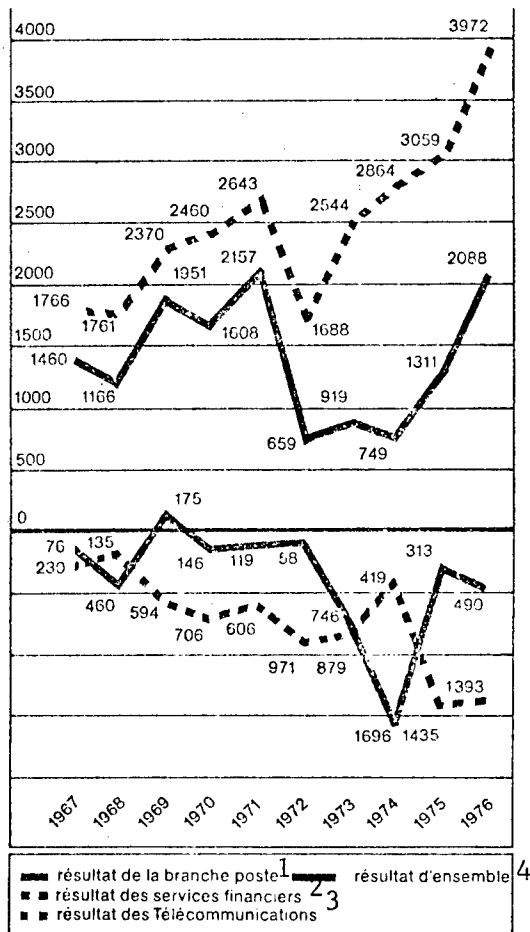

Key

1. Postal branch results
2. Financial services' results
3. Telecommunications results
4. Over-all results

Postal Service (amounts given in millions of francs)

Type	1975	1976	Variations		Type	1975	1976	Variations	
			Volume	Percent- age				Volume	Percent- age
Personnel costs	10,025	11,717	1,692	16.9	Operational pro- ceeds:	2,984	3,306	+ 332	+10.8
Rates and taxes	255	314	59	23.1	Sale of figu- rines	4,852	5,783	+ 931	+19.2
Works, outside servi- ces and supplies	895	1,002	107	11.9	Charges paid in cash	1,337	1,400	+ 63	+ 4.7
Transport and travel	858	948	90	10.5	Franked offi- cial mail	184	56	-128	-69.6
Various management costs	93	100	7	7.5	Various postal operation pro- ceeds	3,169	3,597	+428	+13.5
Financial costs	485	544	59	12.2	Interoffice mail service	106	443	+337	-
Amortizement	229	300	71	31.0	Other proceeds	12,632	14,585	+1,953	+15.5
Interoffice mail ser- vice	104	150	46	44.2	Total operations	12,945	15,076	2,131	16.5
Other costs*	1	1	-	-	Expenditures in previous finan- cial years*	-39	72	-111	-
					Exceptional pro- ceeds*	69	-28	-97	-
Total operations	12,945	15,076	2,131	16.5	General Total	13,136	14,617	1,481	11.3

General Total	12,906	15,148	2,242	17.4	Credit Balance	230	-530	-760	-
---------------	--------	--------	-------	------	----------------	-----	------	------	---

*Insignificant fluctuation

Financial Services (amounts given in millions of francs)

Type	1975		1976		1975		1976		Variations	
	Volume	Percent- age	Volume	Percent- age	Volume	Percent- age	Volume	Percent- age	Volume	Percent- age
Personnel costs	1,605	9.4	1,771	9.4	914	9.4	838	8.3	-	-
Works, outside services and supplies	204	12.7	230	12.7	Operational proceeds*				76	-
Financial costs	6,045	6.6	6,566	6.6	Repayment of services to various agencies				+	77
Amortizement	79	17.7	93	17.7	Financial proceeds	7,211	9,116	+1,905		+26.4
Interoffice mail service	2,417	13.1	2,733	13.1	Interoffice mail service	55	58	+	3	+ 5.5
Other costs**	80	-	366	-	Drawings from reserves for CNE	536	-	-	536	-
					Other proceeds***	22	20	-	2	-
Total operations	10,430	12.7	11,759	12.7	Total Operations	8,995	10,366	+1,371		+15.2
Expenditures of previous financial years or of exceptional nature**	91	-	16	-	Proceeds from previous financial years or of special nature**	90	41	-	49	-
General Total	10,521	11.9	11,775	11.9	General Total	9,085	10,407	+1,322		+14.5
Credit Balance	-1,4326		-1,368		Credit Balance		+ 68			

[Notes from previous page]

*The figures given refer only to the proceeds from the financial services' charges and to various operational proceeds (section 7001 A 40 and 70 of the budget). It is therefore proper to add to the operational proceeds (838 million) the proceeds from the reimbursement for financial services rendered in order to determine the real total of operational proceeds (1,172 million francs) entered under the over-all operational account.

** Insignificant fluctuations.

Telecommunications

(Amounts given in millions of francs)

Type	1975	1976	Variations	
			Volume	Percent- age
Personnel costs	8,054	7,128	1,074	17.7
Works, outside services and supplies	1,763	2,191	428	24.2
Amortizement	2,704	3,492	788	29.1
Interoffice deliveries	800	914	114	14.2
Second section expenditures involving operations	1,445	1,581	136	9.4
VAT for leasing operations	138	186	48	34.8
Other costs*	1,079	1,544	465	-
Total Operations	13,983	17,036	3,053	21.8
Expenditures of previous financial years or of an unusual nature*	386	292	- 94	-
General Total	14,369	17,328	2,659	20.5
Credit Balance	4,098	3,957	- 141	
Operational proceeds	15,671	19,404	+3,733	+23.8
Secondary proceeds	190	250	+ 60	+31.6
Works done by agency for itself	502	589	+ 87	+17.3
Interoffice deliveries	97	143	+ 46	+47.4
Amortizement of leasing debt	227	278	+ 51	+22.5
Services to be billed	354	335	- 19	- 5.4
Other receipts*	1	10	+ 9	-
Total Operations	17,042	21,009	+3,967	+22.7
Proceeds from previous financial years*	1,033	10	-1,023	-
Exceptional proceeds	391	267	- 124	-
General Total	18,466	21,286	+2,820	+15.3

*Insignificant change

.8094

CSO: 3100

SWITZERLAND

SWISS PARTICIPATION IN WEATHER SATELLITE PLANNED

Zurich NEUE ZUERCHER ZEITUNG in German 10 May 78 p 17

[Article by U.M.: "Better Weather Forecasts From Space -- Swiss Participation in Meteosat I Satellite Project"]

[Text] Bern, 8 May -- Switzerland is also planning to participate in the utility phase of the Meteosat I weather satellite. The Federal Council is therefore asking the confederation's councils to ratify an appropriate international agreement.

The Meteosat I weather satellite was launched successfully on 23 November 1977 by NASA (National Aeronautics and Space Agency) at Cape Canaveral (United States) and was placed in orbit 36,000 km above the Gulf of Guinea. Every half hour since then it has sent back to the earth pictures that allow a comprehensive cloud survey and provide data on temperature, humidity and wind conditions.

To Switzerland Via Odenwald

The photographs transmitted by Meteosat I are first received by an installation of the European Space Agency (ESA) in Odenwald in the FRG and processed in the ESA's meteorological data processing center in Darmstadt. The pictures prepared in Darmstadt are received in Switzerland by Radio Switzerland, Inc at the receiving station in Colovrex by authority of the Swiss Central Meteorological Institute; they are then forwarded via telephone lines to the Central Institute in Zurich and to its annexes. Zurich is scheduled to receive its own receiving installation in 1980.

Information for the Weather Service

The Meteosat data provide the Swiss weather service with a continuous and comprehensive picture of weather conditions over a large area. In contrast to traditional means, the satellite makes it possible to obtain clearer knowledge than ever before of the inception, development and movement of such important weather phenomena as tornadoes, thunderstorms, storm fronts and fog banks. For Switzerland the newly acquired data permit

a better assessment in particular of the influence of the Alps on the weather. This information is also important for weather forecasts.

Contracts for Swiss Industry

Under the "Meteosat Agreement," Switzerland has to date participated only in the launch phase and the succeeding 6-month test phase at a cost of 22 million francs. For its part, Swiss industry received various development and construction contracts as a result of this project. Produced in our country were mechanical and electronic testing equipment and the prototype of a universally adaptable receiving station for secondary data.

Financial Effects

From a purely technical standpoint Switzerland would indeed be in a position to use the satellite information even without being party to a further agreement with the European Space Agency. If, however, several states were to refuse to help finance the utility phase, the satellite and its ground facilities could no longer be operated following the test phase. Out of solidarity with the other partners in the Meteosat program and with the World Meteorological Organization, Switzerland should therefore -- in the opinion of the Federal Council -- also participate in the utility phase. Thus, for the years 1978 and 1979 Switzerland would have to make payments totaling 1.93 million francs to the European Space Agency, which is charged with carrying out the ambitious Meteosat program. The appropriate amounts would for the time being be charged to the budget of the Swiss Central Meteorological Institute and would be included in the new federal financial plan.

For optimum use of the Meteosat pictures, supplementary investments of approximately 1.41 million francs are needed for the satellite receiving station in Colovrex and for the analysis and cataloging of information at the Central Institute in Zurich. These additional costs are to be spread over the years between 1977 and 1980 and are also broken down accordingly in the budgets and the financial plan.

7458
CSO: 5500

BUSINESS POLICY, ORGANIZATION OF POST OFFICE DETAILED

Paris REVUE DES PTT DE FRANCE in French No. 1, 1978 pp 62-72

[Summary of two lectures given by Messrs K. Gowen, senior director in London, and D. Loosemore, regional director in Bristol, at the Congress Hall of the State Secretariat for the PTT in Paris, on 18 May 1977: "Commercial Policy and Organization of the British Post Office"]

[Text] The Past -- Statute of a National Corporation

Prior to 1969, the British Post Office was a state administration. It was headed by a minister -- the Postmaster General -- who was directly accountable to Parliament for daily management. The main branches -- the postal service and telecommunications -- were run as a single organization.

But this administration had turned into a very large business with very extensive commercial activities and a manpower of more than 400,000 postal employees.

In 1966, the Post Office handled:

- 11,300 million letters;
- 6,900 million telephone communications.

The average number of letters mailed per person per year has gone up as follows:

- 13 in 1839;
- 66 in 1914;
- 127 in 1920;
- 198 in 1977.

Its investment program was superior to that of all the other enterprises, with the exception of the electric company.

Its personnel represented nearly 2 percent of the working population of the United Kingdom. This represented half of the number of public officials and the size of the civil service always gives rise to criticism in our country.

The need to manage these services like a commercial enterprise had become obvious. If the Post Office had to function according to commercial principles, it was important that it be headed by a president and a board of directors who would be responsible for the management of the business. It was necessary to replace the subsidiaries and hierarchy of the civil service, which gave a certain rigidity to the system, with a more flexible personnel statute. Therefore, the employees of the Post Office are no longer civil servants.

Thus, in 1969 legislation was introduced making the Post Office a national corporation, a "nationalized industry" as we say in England. Henceforth, the daily management of the Post Office was no longer in the hands of Parliament, but in the hands of the national corporation.

The Current Situation

The new president and his board of directors are responsible for four sectors:

- Postal Service: the oldest sector, which requires a great deal of manpower (78 percent of its expenditures are personnel expenditures) and is in decline;
- Telecommunications: a large capital consuming sector, in the process of rapid expansion;
- Postal Money Orders and Data Processing: two young sectors in the process of expanding.

The reasons behind the separation of the sectors were the following:

- 1) Each sector had very different management characteristics;
- 2) Each of them had a different growth rate;
- 3) Each of them had its own requirements to achieve successful management.

The general management is carried out by the president and by the board of directors of the Post Office, the members of which are appointed for a certain number of years. The various sectors are run like commercial enterprises, distinguished by directors general responsible to the board of directors, of which they are also members. Thus, the "Postal Service" is managed by a director general; another director general is in charge of "Telecommunications" as well as the "Data Processing" sector, three-quarters of the activities of which are related to telecommunications. A third director general concerns himself with "Postal Money Orders."

The four sectors do not mutually subsidize each other.

Following are the manpower figures for the four branches of activity. "Telecommunications" has overtaken the "Postal Service" and is now far ahead.

Table 1.

Post Office Personnel on 31 March 1976	
Telecommunications.....	237 693
Postal Service.....	174 287
Postal Money Orders.....	3 339
Data Processing.....	4 116
Central Administration.....	1 230
	<hr/>
	420 665

The "Postal Service" Branch

We are going to talk about the "Postal Service" branch. As a matter of fact, "Telecommunications" are very profitable. This year, telephone subscribers will be given a refund in order to reduce the level of profits. The problems come from the Postal Service, not only in the United Kingdom, but in most other countries as well, notably in the United States and in the Federal Republic of Germany. It is difficult to prevent deficits, but in the course of last year (1976-1977) we have discovered a formula which has enabled us to show a profit.

Organization -

The organization of our "Postal Service" branch is as follows:

- a national management comprised of a director general and specialized directors (marketing, operations, mechanization and construction, personnel, finance);
- a regional level: there are 10 regions, among which that of London is the largest and the most important. Each one is headed by a director, who is accountable to the director general;
- local management units; there are approximately 180 of them, each of which has been placed under the authority of a head postmaster. Each one of them is responsible to his regional director.

There are numerous subordinate units in each main postal district.

For example, when I was head postmaster in Brimingham*, I controlled:

- a large mechanized body which handled 2.5 million letters a day;
- a large mechanized parcel sorting center which handled 750,000 parcels a day;
- 20 distribution centers;
- 54 windows, which were the property of the national corporation;
- 420 secondary offices;
- a car pool with 520 transportation vehicles;
- 6500 employees;

* M.D. Loosemore

- and, also, 10 offices of the national corporation in the charge of the postmasters, but without any other administrative personnel, and of window and mail sorting employees. Those offices serve the neighboring cities, the population of which could reach 120,000 inhabitants.

In Great Britain, the number of windows at the disposal of the public is important. There are a total of 23,660 of them, that is to say 1 per 2,380 inhabitants.

Table 2.

	Post Offices	Number of inhabitants per office
Italy.....	13 672	4 070
Belgium.....	2 550	3 838
Denmark.....	1 373	3 712
France.....	17 745	2 967
Germany (Federal Republic of).....	22 411	2 768
United Kingdom.....	23 660	2 380

Source: UPU [Universal Postal Union] questionnaire. The figures refer to the year corresponding to the 1974-1975 budgetary year in the United Kingdom.

In the next table, we have presented the personnel distribution of the 174,287 postal employees of the "Postal Service" branch.

Table 3.

"Postal Service" Branch Personnel on 31 March 1976	
Directorate general of the Postal Service.....	3 464
Regional directorates.....	3 280
National Office of Television Licensing.....	685
Post Offices.....	35 685
Mail Routing and Distribution Service.....	124 398
Technical Services.....	3 724
Automobile Transportation.....	3 051
	174 287

Furthermore, there are 21,300 managers of postal agencies working for us. As a rule, they are businessmen who are paid according to the level of mail volume which they handle.

Services -

The services we render are the following:

- a service for first class letters (93 percent of these are delivered on day B);
- a service for second class letters, with planned routing but slower (96 percent of these are delivered on day D). Within the framework of second class service, we are proposing a less expensive service of mailings handed in in batches and in large quantities, with a 7 day delay between deposit and distribution. Deposits of more than 4,250 pieces would be given a discount calculated at a variable rate, and deposits of more than 1 million pieces would receive a 30 percent discount. The depositor would have to comply with several conditions with regard to preliminary sorting, hours of deposit, period of deposit, etc.;

There is a difference of 2 pence (17 French centimes) between the postage rates for first and second class letters. The percentage of the deposits for first and second class are about 36.5 percent and 63.5 percent respectively. The total number of letters being mailed is approximately 31 million per day;

- a service for special delivery letters -- with hand to hand forwarding and release at the time of delivery -- which is expensive to manage and particularly aimed at valuable objects;
- a service for certified letters: this is a less expensive variant of the above, aimed at documents for which a release at the time of delivery is required. In this case, the letter is separated from the others only at the time of sorting after arrival at the distribution office and the compensation provided for in case of loss is small;
- a service for door to door delivery of printed advertising matter with no address; the depositors may choose the postal code districts to be served;
- a so-called "Freepost" service for the benefit of advertising bodies, whereby the postage is paid by the sender. It is a variant of the prepaid responses service, which also exists;
- a "Datapost" (Postadex in France) service, a contractual service with delivery guaranteed on day B, reserved for data processing documents being sent to computer centers, etc.;
- a service for parcel post, either at the risk of the sender or with the possibility of compensation with payment of insurance.

Other kinds of special services are meant to fill the particular needs of the customers (Expresspost, Speedpost and Exchangepost).

Table 4.

Rates (Initial Rate, 60 grams)				
	1st Class		2nd Class	
	In Pence	In Francs	In Pence	In Francs
1973.....	3.5	0.29	3.0	0.25
1974.....	4.5	0.38	3.5	0.29
1975 (March).....	7.0	0.59	5.5	0.46
(September).....	8.5	0.72	6.5	0.55
1976.....		No change		
1977 (June).....	9.0	0.76	7.0	0.59

1 penny: 0.085 francs

Since the time of Rowland Hill, in 1840, our postal rates have been the same for the whole country. In order to safeguard this system, we have a monopoly for the transportation of letters. Without this monopoly, there would be a risk that competitors might accept to deliver mail locally at prices lower than those of the Post Office, while refusing to handle letters to be delivered in far away places.

But the parcel post service is not a monopoly and we are thus competing with other carriers who can make a choice concerning the merchandise to be transported and the destinations to be served.

Our trump cards are convenience, the quality of the service (75 percent of the mailings are delivered on day C) and the low level of losses and spoilages.

The parcel post service shows a deficit which we are constantly reducing.

Our windows handle all operations of the postal service and the postal money orders and ensure payment of the numerous social allowances which exist in Great Britain: retirement benefits, family allowances, unemployment benefits, etc. We are agents of the National Savings Bank, of the Service of Television Licensing, of the passport service. We draw an income from advertisements posted in our own offices as well as from photograph booths and photocopy machines which are set up there, and for everything which the government might want distributed from time to time (gas stamps, butter stamps, etc.).

Our workweek amounts to 5 and a half days. There is no pick up on either Saturday afternoons or Sundays. Our windows are open from 0900 until 1730 hours, except for a few special windows such as those on Trafalgar Square.

We ensure two mail deliveries a day from Monday through Friday and one on Saturday. In the cities, the national normal timetable for the first

distribution is at 0700 hours for the first delivery and at 0930 hours for the last (0915 hours in London). Eighty-two percent of the letters are delivered during the first distribution. There is a daily parcel post delivery, Monday through Saturday, and we guarantee delivery everywhere.

Financial Questions -

At the time when the national corporation was established, the objective set for the postal service was to yield 2 percent of the total amount of the expenditures. It should be remembered that there is no system of subsidy among the four branches which make up the present Post Office. There would be neither financial discipline nor any stimulation in the area of management if one of the branches could count on subsidies. Thus, the postal service can only count on itself.

During the first years of the existence of the national corporation, we did not have the commercial freedom we had expected. To avoid showing a deficit, any enterprise must be able to decide on the economic price of the product or service it supplies. In the beginning we did not have that freedom, because the government was trying to control inflation and to slow down the cost of living increase. We were prevented from invoicing an economic price for our services at a time when emoluments for our personnel were rising very rapidly.

Under those circumstances, we could not hope to carry out our activities with a profit and our losses had to be compensated by the taxpayer. Table 5 shows the unfavorable evolution of this situation.

Table 5.

Financial Results of the Postal Services (in millions of £)					
	1971-1972	1972-1973	1973-1974	1974-1975	1975-1976
Receipts.....	515.5	559.7	630.3	770.8	1088.6
Expenditures....	528.1	602.2	687.8	880.0	1097.8
Loss.....	12.6	42.5	57.5	109.2	9.2
In millions of francs	106.1	357.9	484.2	919.5	77.5

Later on, in 1975, the government altered its policy. We were asked to limit our deficit to a maximum of £ 70 million (590 million francs) for 1975-1976 and to produce a profit as of 1976-1977. At the same time we were given greater freedom in matters of rate structure. You may note that for the year 1975-1976 we brought our deficit down to £ 9.2 million (77.5 million francs), which was totally within the limits of the £ 70 million set by the government. Last year (1976-1977), we made a profit of £ 24.3 million (205 million francs).

The postal service no longer needs to be a burden on the taxpayers in our country. It must function as a commercial enterprise, without a loss.

To increase the rates is not an easy matter to accomplish. We have to persuade various bodies, such as the National Council of Post Office Customers, the Department of Prices and Consumer Protection and the Department of Industry, of the soundness of our cause. All of this takes a great deal of time. The transformation of the financial results of the postal service from a deficit to a profit in the space of 2 years -- and 2 years of galloping inflation -- has been practically a miracle. Rate increases have only been part of the success formula used.

What Other Important Factors Intervened?-

The capacity of the leaders to respond to the challenge presented to them constituted a vital element. The results achieved were satisfactory because work relationships in the postal service branch are excellent and because the unions have supported the savings campaign on the condition that reductions are carried out at all levels, in the central administration, in the regions, among the cadres as well as among the employees. The amount of savings thus realized during the last 2 years reached £ 55 million (463 million francs) and new savings on the order of £ 24 million (202 million francs) will be achieved in 1977-1978. There is a general desire to respond to the government's firm injunction to bring the postal service to a financial situation showing a surplus. The unions accepted the fact that accelerated methods had to be used to adjust the manpower to the volume.

There were two rate increases in 1975, while we were moving toward more economical prices. Such increases always entail a reduction in volume, because the depositors try to maintain the level of their expenditures. But this time, the drop in volume was less than it might have been, due to the enormous efforts made by our colleagues in the new marketing division to retain old clients as well as to attract new ones. This marketing effort has played an important role in that it has contributed to strengthening the collaboration of the unions and to maintaining good morale. The personnel could see that we were acting in a very positive manner in order to attract as much volume as possible. Therefore they gave us their support in accepting the other unpopular measures we had to take.

The most important of these measures was a reappraisal of the services in order to determine where savings could reasonably be made.

We decided on several changes which would allow savings of £ 13.4 million (112.8 million francs), notably:

- no pick up rounds on Sundays;
- no pick up rounds on legal holidays;
- no pick up rounds on 27 December;
- no late pick up rounds (2000 to 2030 hours);
- no shipping of parcel post on Saturdays;

- a reduction in the quality of second class service, the delivery of which is put off from day C to day D, which allows its sorting to be done outside the periods during which the remuneration rates are higher (1900 hours);
- closing of the windows on Saturday afternoons.

Thus, thanks to a few service reductions, to collaboration of the personnel with regard to the acceleration of the reappraisal of the services we mentioned above, to the largest savings campaign the postal service has ever known, to rates moving toward an economic appraisal, and to the important new marketing department, we have brought the postal service into a profit showing situation.

The Marketing Department -

A positive step in the right direction was taken with the establishment of our marketing organization. While the Post Office was an administration, we were anonymous, timid and more concerned with regulations than with commercial possibilities. Now, this attitude has changed completely. We have taken the place on the market which rightly belongs to us. Our representatives visit all the large companies in the country. There are close personal relationships between our representatives and our clients from the business world. And we all get out in the field to sell our services.

The postal service Marketing Department is placed under the authority of a specialized director from the Central Administration. He is supported in the field by a commercial service, including:

- 10 marketing directors (one per region);
- 17 district sales directors;
- 130 postal service representatives, having a car at their disposal like travelling salesmen.

This Marketing Department has two main tasks:

- 1) To elaborate policies which would allow for the fulfilment of the current and future needs of both the business customers and the private customers;
- 2) To maintain the present volume and attract new volume at rates which the users will agree to pay and which will cover the operational costs and produce a profit.

Information concerning our services and on the best way to use them is an important element of the art of selling in the commercial sector. We have set up a central file on the most important companies in the country to which we send our information pamphlets, designed to facilitate the sale of our services. For the personnel of interested firms, we also offer a course on how to manage a mail room efficiently.

As far as the parcel post service is concerned, for which we do not have a monopoly, nearly 50 percent of our volume is currently ensured by contract. This helps to maintain the volume when rates go up.

A special service of prepaid responses with allowance for refunds, has been set up for first class letters. It is meant to respond to the needs of clients who receive more than a million pieces of correspondence per year and who want to pay the postage costs normally carried by the sender. At the present time, we handle 71 million letters per year within the framework of this service.

Our marketing personnel constantly try to come up with new services to satisfy the needs of our clients. The most important new demand to be identified during the last few years may well have been that for a reliable night mail service for the transportation of urgent dispatches (for example, data intended for computer centers). We call this service "Datapost" and its receipts are currently higher than £ 7 million (59 million francs) per year.

An enumeration of our marketing activities would not be complete if it did not mention stamp collecting. Commemorative stamp issues, special stamp cancellations, etc., yield approximately £ 7.5 million (63 million francs).

We limit the number of special issues to six, plus one issue for Christmas, because this number is the maximum the market can handle.

Table 6.

Philatelic Receipts (in millions of £)					
	1972-1973	1973-1974	1974-1975	1975-1976	1976-1977
Receipts.....	3.1	3.4	4	6.1	7.5 (forecast)
Expenditures....	2	2.2	3	3.7	
Profit.....	1.1	1.2	1	2.4	
In millions of francs	9.3	10.1	8.4	20.2	

During the last few years, the efforts of our marketing agents have allowed us to substantially increase our receipts. The results of their achievements are closely checked and, in 1976-1977, the contribution of marketing to the receipts reached £ 86 million (725 million francs).

Table 7.

Contribution of Marketing to Receipts (in millions of £)	
1973-1974.....	30.6 (257.7 million francs)
1974-1975.....	42.7 (359.5 million francs)
1975-1976.....	75.3 (634.0 million francs)
1976-1977 (estimate).....	86.1 (725.0 million francs)

The Future

If the last 2 years have been eventful, the next 2 years will be even more so.

The Board of Directors -

This summer will see the appointment of a new president of the Post Office, who will probably come from the industrial or commercial sector. There will also be changes among the directors general of the different branches.

Industrial Democracy -

The new president will join us at a time when we are getting ready to launch a 2 year experiment in industrial democracy. The government is very eager to see a beginning of worker participation in the management of the large companies in Great Britain, at the level of the boards of directors. The extensive use of the method of mutual consultations between management and the unions has always been a characteristic of labor relations at the Post Office. The union officials are all Post Office personnel and they are conversant with the functioning of the enterprise. They are responsible and constructive during discussions concerning specific problems. Most often, the interests of the enterprise and those of the personnel are similar. It is not surprising that the Post Office has been called upon to play a leading role in the country with regard to the application of the new concept of industrial democracy. The new board of directors will be made up of seven members belonging to the management, seven members appointed by the Post Office unions and five independent members, among whom there will be a representative of the interests of the customers, plus a president. It is expected that this 2 year experiment will begin in January 1978.

In certain regions there are already regional boards of directors which include up to four non-executive members from industry, commerce, education and the unions. It is to be expected that soon those boards will also have to be reconstituted to include members appointed by the Post Office unions.

Talks are also under way to figure out how to apply this new idea at the level of the local management. In the head postmaster offices, frequent dialogues have already been set up between managers and representatives of the personnel on all subjects relating to the daily functioning of the office. The only change we might consider here is the addition of an orientation committee whereby union representatives other than those responsible for the negotiations will join the managers to study the plans on the basis of which the office must be managed.

Carter Commission -

Soon, the commission appointed by the government to study the organization of the Post Office will have to hand in its report.

Indiscretions in the press have hinted that the report will advocate a complete separation of the Post Office into two independent corporations. It would seem probable that the plan would involve grouping "Telecommunications" and "Data Processing" (which is a subsidiary activity of the former) into one corporation, while the "Postal Service" and the "Postal Money Orders" (which make extensive use of the windows, the systems of monetary deposits through postal channels and the routing services) would form another distinct corporation. Even though these are nothing but speculations (many discussions of the report will take place before the decisions are made and the necessary legislation has been introduced), it is clear that we are going to work in changing situations rather than in stable ones.

Budgeted Operations Plan -- Control -

The "Postal Service" branch has a long term operations plan based on forecasts over a period of 10 years, as well as a medium term operations plan with forecasts covering 5 years. However, it is subordinate to a plan and to a yearly operations budget approved by the president and the board of directors of the Post Office. Firm objectives and maximum expenditures for the functioning of the routing and window services, the secondary offices, the premises and all other expenditures concerning the postal service, are assigned to each region. Each director is strongly urged to economize. The national total of the budgets lies within the framework of the expected receipts in terms of the volume level.

Similarly, each head postmaster must prepare a plan for the coming year, including all the arrangements he has been able to think of to reduce the operating costs. He must indicate the amounts and the number of manhours he will need to run his service. In turn, his director will specify the sums which will be allocated to him for his budget -- these figures are always calculated at the lowest level so that it is always necessary to find means which would allow for a reduction of those costs.

This method is known as "downward" budgeting. The head postmasters would much prefer an "upward" budgeting whereby their estimates would be retained for the budget, but the prospects for such a change are very slim.

The development of the situation, for each operation or for each secondary expense item, is verified every 4 or 5 weeks at the local, regional and national level. The real figures and the anticipated figures are compared by computer.

Moreover, a goal is stipulated for each director and each head postmaster in terms of marketing and the level of new activities to be reached during the year for various categories, such as direct publicity, parcel post contracts, philately, etc.

At the end of each year, the management of each service head is examined; the director general meets with each director and the director with each head postmaster. These meetings are followed by appraisals and suggestions.

Changes Within the Service -

The future diagram of our services is liable to be changed as the balance between price and service brings changes. The client is very much aware of the cost price. A price hike is always unpopular. However, there comes a time when a choice must be made between a price increase and a reduction in service. At the time when we became a national corporation, the law imposed the creation of a National Council of Post Office Customers, which was meant to look after the interests of the clients. We are legally bound to consult it each time we plan changes in the service or rate increases.

Thus, there is an easily available body to let us know what the preferences of the customers are. Most of our services have already seen their cost price submitted for evaluation and they have either been made profitable or been abolished, so that the range of possible new changes has been reduced. At the present time, studies are being made on the possibility of reducing the costs of delivery services through the possible use of the following means:

- reduce the number of deliveries to one per day, which would represent a savings of approximately £ 38 million (320 million francs), and of 10,000 postal employees. This solution might possibly be applied in the future, but it would result in a much later delivery for many inhabitants and the unions are strongly opposed to it;

- put up mailboxes along the highway when the houses have long driveways (more than 15 meters from the highway). Their installation could produce a savings of £ 7.5 million (63 million francs) per year. However, in Great Britain everyone has received his mail in a mailbox since the era of Queen Victoria and it is hard to get rid of a facility which has existed for so long.

Measurement of Volume Flow -

A more sophisticated formula for measuring the volume flow will be applied to provide a viable base for the profit payment systems which will probably characterize the following stage of the wage policy in the United Kingdom.

Mechanization -

Future developments will most certainly bring us into an era of higher mechanization in the handling and sorting of mail.

We have made progress in the application of our national plans concerning the sorting of letters and parcel post which, not so very long ago, were being sorted in 1600 offices.

According to the plan for letter mail, all the sorting of the category "letters" will ultimately be concentrated in 80 mechanized letter sorting centers. At the present time, 19 offices have been equipped and 10 more

will be integrated into the system within the next 18 months. Within the next 2 or 3 years, approximately 50 percent of the "letter" mail will be sorted mechanically.

The plan for parcel post, like the preceding one, implies a concentration of the volume flow in vast operational units for handling and delivery.

The plan provides for 27 centralizing offices tied to a system of transportation services to be handled by road for distances up to 120 miles and by railroad for longer runs. We will use containers rather than bags. In the mechanized offices of Bristol and Southampton, the sorting rate for parcel post has reached 60 units per hour.

The overall personnel reduction due to mechanization should amount to approximately 6,000 persons between now and the eighties, but it should be covered by normal departures. We do not expect any surplus problems. The capital gain resulting from the mechanization will be 10 percent.

Our postal code system is an essential element of our national routing plan. A particular code is assigned to each important firm as well as to groups of about 20 delivery addresses. Let us note in passing that we are able to sell our list of postal codes to other commercial organizations who use it to set up plans for sales sectors, etc.

Influence of External Factors on Commercial Policy -

But in spite of these successful efforts to make the "Postal Service" branch profitable, it has to be admitted that our task is and will remain a difficult one.

Even when the mechanization program is finished, we will still be large manpower consumers in a period of wage inflation. We will have to fight a constant battle to maximize our internal productivity in order to keep rate increases as low as possible and thus to prevent volume reductions. Technical progress in communication matters, such as the increased availability of telephone service and the computer systems, will undoubtedly change the nature and volume of our activities. To be able to tackle this difficult task, we will need as much commercial freedom as possible and it is only right to say that in that respect we have obtained less than we had hoped for when the new national corporation was brought into existence. This is due in part to the government policy and to social factors relating to industry as a whole. For example, the freedom to raise salaries and rates is limited and consumer protection has become a force to be reckoned with. But nationalized industries and national corporations have had rather less commercial freedom than the rest of industry. They have had to take into account the properly set up customers councils as well as the government's determination in matters pertaining to the setting of financial goals and of maximum loan amounts in order to slow down public spending. Moreover, the Post Office must operate within the framework of the law which set it up as a national corporation. This limits its ability to perform operations

other than those relevant to Postal Service and Telecommunications. For example, we could not provide travel agency services at our windows, nor use the reserve capacity of our transportation vehicles repair shop. We are bound to deliver the mail to every address and new legislation would have to be enacted to allow us to deliver the mail in mailboxes located along the highways or in centralized mailboxes in apartment buildings.

We are bound by law neither to provide illegitimate priority nor to discriminate in the performance of our activities.

It is true that our new statute as a national corporation has created a freedom of thought and changes in attitude, and that Parliament no longer so closely examines the manner in which we perform our daily activities. However, ultimately the degree of commercial freedom which is given us is still as much dependent on the economic and financial policy of the government and on legal restrictions as on our change in statute.

I will conclude this description by reaffirming my conviction that, in spite of the problems of the past and the difficulties to come, the postal services of the United Kingdom can function in a profitable manner. However, the maintenance of the viability of the "Postal Service" branch will depend primarily on a reasonable degree of commercial freedom.

8463

CSO: 5500

END