



# Ionic Doping of Low-Conductivity Structural Resins for Improved Direct-Current Sensing

by Bruce K. Fink, Kenric M. England, and John W. Gillespie, Jr.

ARL-TR-2239

June 2000

Approved for public release; distribution is unlimited.

20000628 020

DTIC QUALITY INSPECTED 4

The findings in this report are not to be construed as an official Department of the Army position unless so designated by other authorized documents.

Citation of manufacturer's or trade names does not constitute an official endorsement or approval of the use thereof.

Destroy this report when it is no longer needed. Do not return it to the originator.

# Army Research Laboratory

Aberdeen Proving Ground, MD 21005-5069

---

---

ARL-TR-2239

June 2000

## Ionic Doping of Low-Conductivity Structural Resins for Improved Direct-Current Sensing

Bruce K. Fink

Weapons and Materials Research Directorate, ARL

Kenric M. England and John W. Gillespie, Jr.

University of Delaware

---

---

## Abstract

---

This investigation developed a methodology for doping high-resistivity vinyl-ester (VE) resins with an organic dopant. The polymeric resin system investigated was a Dow Derakane 411-C50 VE resin. A number of potential dopants were studied, and two in particular, tetrabutylammonium acetate (TA) and tetrabutylammonium iodide, were found to be capable of increasing the ionic conductivity of VE resin without adversely affecting the resin viscosity, mechanical properties, or reaction kinetics. The primary candidate dopant that was characterized in this investigation was a TA organic salt. TA, at a 0.1-weight-percent (wt%) concentration, was shown to have negligible effects on the mechanical properties and reaction kinetics of a curing VE part. TA was also found to slightly increase the rate at which viscosity increases, but not to the extent that would hinder resin transfer molding of a doped VE system. This investigation has proven that doping of VE resin with 0.1-wt% TA is a viable means of controlling and tailoring the conductivity of high-resistivity resins for the application of direct-current (DC)-sensing technology.

## **Acknowledgments**

This research was supported in part by the U.S. Department of Defense (DOD), through the Tuskegee Research Consortium. The authors gratefully acknowledge the research assistance of Sam Bharava of the University of Delaware.

INTENTIONALLY LEFT BLANK.

# Table of Contents

	<u>Page</u>
Acknowledgments.....	iii
List of Figures.....	vii
List of Tables.....	ix
<b>1. Introduction.....</b>	<b>1</b>
<b>2. Background and Theory.....</b>	<b>2</b>
<b>3. Experimental Procedures.....</b>	<b>6</b>
3.1 SMARTweave System Components and Operation.....	7
3.2 Effects of Resin Chemistry on Ionic Conductance.....	8
3.3 Dopant Down-Selection and Characterization.....	9
3.3.1 <i>Dopant Down-Selection</i> .....	9
3.3.2 <i>Characterization</i> .....	10
<b>4. Results and Discussion.....</b>	<b>12</b>
4.1 Effects of Resin Constituents on Ionic Conductance.....	12
4.2 Dopant Down-Selection and Characterization.....	17
4.2.1 <i>Dopant Down-Selection</i> .....	17
4.2.2 <i>Characterization of TA-VE Resin System</i> .....	18
4.2.2.1 <i>Effects of Doping on Ionic Conductivity</i> .....	18
4.2.2.2 <i>Effects of Doping on the DC Sensing and Mechanical Properties of Manufactured Composite Panel</i> .....	20
4.2.2.3 <i>Determination of Dopant Ionization Constant and Equilibrium Concentration</i> .....	21
4.2.2.4 <i>Effects of TA on the Viscosity and Reaction Kinetics of Curing VE Resin</i> .....	23
<b>5. Conclusions.....</b>	<b>26</b>
<b>6. References.....</b>	<b>29</b>
Distribution List.....	31
Report Documentation Page.....	51

INTENTIONALLY LEFT BLANK.

## List of Figures

<u>Figure</u>		<u>Page</u>
1.	VE and ST Monomer Structures and Chemical Makeup.....	3
2.	SMARTweave Single-Node Circuit Schematic.....	7
3.	SNTC.....	9
4.	DC Cell Configuration .....	11
5.	Effect of Variable Concentrations of CoNap on Ionic Conductance .....	13
6.	Initial SMARTweave Voltage vs. Concentration of CoNap.....	14
7.	SMARTweave Voltage vs. Time for Variable Concentrations of Trigonox 239A...	15
8.	Initial SMARTweave Voltage vs. Concentration of Trigonox 239A.....	16
9.	SMARTweave Voltage vs. Time for Candidate Dopants .....	17
10.	Effect of Variable Concentration of TA on SMARTweave Voltage .....	18
11.	Initial SMARTweave Voltage vs. Concentration of TA.....	19
12.	SMARTweave Voltage vs. Time in a SCRIMP Environment.....	20
13.	Resistance vs. Time for Equilibrium Concentration Study.....	22
14.	Conductivity vs. Inverse Concentration of Ions .....	22
15.	Concentration of TA Ions vs. Mass Concentration of TA .....	23
16.	Effect of TA on Viscosity of Curing Doped 411-C-50 Resin.....	24
17.	Degree of Conversion of VE and ST at 30 °C .....	25
18.	Degree of Conversion of VE and ST at 40 °C .....	25
19.	Degree of Conversion of VE and ST at 50 °C .....	26

INTENTIONALLY LEFT BLANK.

# List of Tables

<u>Table</u>		<u>Page</u>
1.	Short-Beam Shear and Open-Hole Compression Test Results .....	21

INTENTIONALLY LEFT BLANK.

# 1. Introduction

As the composites industry grows, there is an increasing need to improve quality and reduce the cost of producing composite structures. To meet these demands, research has focused on the development and refinement of new technologies to sense the condition of a composite during manufacturing. SMARTweave is a patented sensor system that measures and tracks the direct-current (DC) conductance of a resin as it flows into a preform and cures [1–4]. This is done through an overlapping, but not touching, grid of wires; one set serves as excitation leads, and an orthogonal set in a parallel plane serves as sensing leads. The resin acts as a resistor. Under an applied voltage, current is induced in a circuit that enables the conductance to be monitored during the process.

One common approach in single-point flow and cure sensing is to monitor the dielectric response of a material by the application of an alternating current. However, such techniques track not only the ionic conductivity of the curing resin but a more complex dielectric response. The use of a DC measurement technique allows for simpler measurement of DC conductance and for rapid continuous multiplexing of potentially thousands of “point sensors” in a mold.

Potential difficulties are associated with DC sensing of low-conductivity resin systems. Vinyl-ester (VE) resin systems are widely used in liquid-molding processes because of their low viscosity and ability to cure at room temperature. Low-viscosity room-temperature-cure resin systems offer reduced production costs and are therefore widely used by many composites manufacturers. However, the low conductivity of VE systems makes it difficult for a DC-sensing system to sense the presence and cure of the resin.

This paper investigates dopants that will raise the conductivity of high-resistivity resin systems. The effects of resin chemistry and doping on ionic conductivity are characterized through the use of SMARTweave single-node test cells. Further, the effects of doping on the mechanical properties, viscosity, and reaction kinetics of a curing VE resin are investigated

through mechanical testing, viscometry, and transmission Fourier-transform infrared (T-FTIR) spectroscopy.

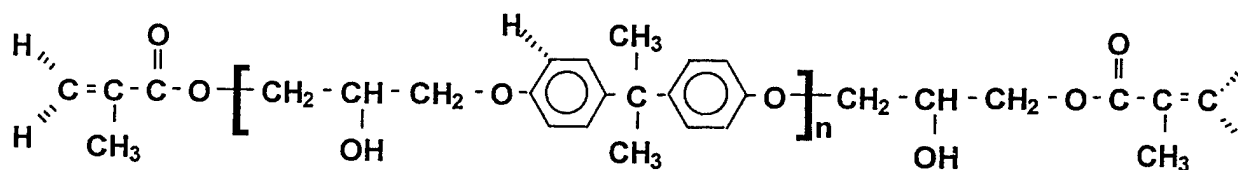
## 2. Background and Theory

Two basic groups of parameters govern the operation of DC-sensing systems: (1) the geometric configuration of the sensing system and (2) the material properties of the resin system. The geometric parameters of interest are conductor separation distance and surface area. The conductor separation distance influences the time it will take mobile charge carriers, ions, to migrate across the potential difference created between the conductor surfaces. The conductor surface area affects the number of ions that transfer charge from the liquid medium to the conductor in a unit time. The material properties of interest are viscosity, concentration of ions, and size of ions. Both the resin viscosity and dopant ionic radius influence the mobility of the ions.

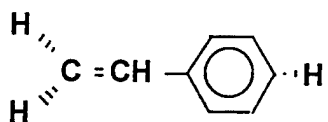
This investigation is concerned with the effects of the material parameters and doping on the ionic conductivity of VE resin. The resin system under investigation is the Dow Derakane VE 411-C-50 resin system with 50% styrene (ST) content, designated VE. Figure 1 shows the chemical structure and makeup of VE and ST monomers. Cobalt naphthenate (CoNap) is used as an accelerator along with a cumene hydroperoxide-based catalyst, Trigonox 239A. The system is mixed with 2.0-weight-percent (wt%) Trigonox 239A and 0.2-wt% CoNap then cured at room temperature. A number of potential charge carriers were investigated for their ability to lower the resistivity of the VE resin system by increasing the concentration of ions.

When choosing a dopant for the VE system, care was taken to choose a dopant that would ionize and separate into its ionic components, but not adversely affect the curing resin. An organic salt with a weak cation/anion pair is needed in order to avoid cross-linking of the salt with the vinyl groups, called a complex. Acceptable dopants would also have a short ionization time and low cost, relative to the other resin components. Through doping with a binary

### Methacrylated DGEBA Monomer - Vinyl Ester



### Styrene



**Figure 1. VE and ST Monomer Structures and Chemical Makeup.**

compound, the sizes and interactions between ions could be determined. The resistivity of the resin in this case is a function not of resin chemistry, but of dopant concentration. In this way, the resistance of doped VE resin could be investigated and the relationship between ion concentration and DC sensing determined.

In work by Schwab, Levy, and Glover [5], the resistance of a parallel plate DC-sensing system was reported to be a function of the separation distance between plates ( $L$ ), the surface area of the plates ( $A$ ), the viscosity of the resin ( $\eta$ ), the charge of ions in the system ( $Q_i$ ), the concentration of the ions in the system ( $C_i$ ), and the radius of the ions in the system ( $r_i$ ), or

$$PR = \frac{6\pi\eta L\pi\eta\Lambda}{AA \sum_i \frac{C_i Q_i^2}{r_i}}, \quad (1)$$

where viscosity is in Pascal-seconds, length in meters, area in square meters, concentration in numbers of ions per cubic meter, charge in coulombs, and ionic radius in meters. This relationship was developed by balancing the viscous drag force acting against an ion as it moves

through a resin and the electromotive force driving an ions toward and away from the charged plates.

For the SMARTweave DC-sensing system, the geometric parameters of L and A are determined by the junction formed by the sense and excitation leads. Due to the dependence of resistance on the concentration, charge, and size of ions, doping offers an effective means of lowering the resistance of low-conductivity polymeric materials.

In polymeric materials, two modes of electrical conduction are possible: (1) ionic modes and (2) electronic modes. In the former case, current flow results from the motion of ions. The latter involves motion of electrons along a conjugated polymer chain. In a curing system, no system of conjugation exists; thus, one relies on polar/ionic charge carriers to increase ionic conductivity. Ionic conductivity in polymers has recently gained increased attention because of applications in energy-conversion devices and chemical sensors [6, 7]. Ionic conductivity is the product of three terms: (1) the carrier charge ( $Q_i$  in coulombs), (2) the concentration of charge carriers ( $C_i$  in ions per cubic meter), and (3) the average velocity of a charge carrier in an electric field ( $S$  in meters per second). Thus, one can write an expression for the specific conductivity as

$$\sigma = Q_i C_i S. \quad (2)$$

Most polymers are poor ionic conductors because they are primarily organic and the salts are insoluble in the polymer matrix. The applications of polymeric ionic conductors require a polar ion-solvating polymer like poly(ethylene oxide).

The addition of an organic salt to a nonpolar resin does not guarantee an increase in ionic conductivity. A salt with a high degree of ionization in the polymer matrix with a small effective hydrodynamic volume of the resulting ions will result in maximum conductivity. The degree of ionization depends on the strength of association between counterions, water hydration, and complex formation. The strength of association for a simple ionic bond is given by Coulomb's law as

$$E = \frac{Q^2}{4\pi\epsilon_0\epsilon d}, \quad (3)$$

where  $Q$  is charge ( $1.602 \times 10^{-19}$  C),  $\epsilon_0$  is the permittivity of free space ( $8.85 \times 10^{-12}$  F/m),  $\epsilon$  is the dielectric constant of the medium (3.32 for VE resin), and  $d$  is the distance between ionic cores in meters. Equation (3) applies well when hydration energies and metallic bonds are not important. It suggests that increased ionic radii will increase the degree of ionization in low dielectric materials.

From the limiting ionic conductivity of each ion, a hydrodynamic radii is estimated [8]. The limiting ionic conductivity for these calculations was determined in water; thus, they include the effective size of the hydrated ions. The resin system used in this study does contain trace amounts of water, and hydrated ions are expected to be present.

The degree of ionization, the equilibrium constant, and the concentration of ions can be calculated using equations (4) through (8). The measured molar ionic conductivity ( $\Lambda$ ) is calculated as

$$\Lambda = \frac{1}{\rho_v C_d}, \quad (4)$$

where  $C_d$  is the concentration of dopant in grams, and  $\rho_v$  is the resistivity of the resin in ohm-meter. The resistance of the resin system being used can be measured using a DC conductivity cell. Once resistance has been measured with a DC cell, resistivity can be calculated by the following equation:

$$\rho_v = \frac{2\pi L_c R}{\ln \frac{D_2}{D_1}}, \quad (5)$$

where  $R$  is the measured resistance of the material in ohms,  $L_c$  is the length of cylinders in meters,  $D_1$  is the outer diameter of the inner cylinder in meters, and  $D_2$  is the inner diameter of the outer cylinder in meters.

The degree of ionization ( $\psi$ ), and equilibrium constant ( $k$ ) can be calculated using equations (6) and (7):

$$\Psi = \frac{\Lambda}{\Lambda_{\max}}, \quad (6)$$

and

$$k = \left[ \frac{\Psi^2}{1 - \Psi} \right] C_d. \quad (7)$$

The concentration of ions ( $C_i$ ) in solution within the resin system can be calculated as

$$C_i = \frac{\Psi M}{M_w V} 6.023 * 10^{23}, \quad (8)$$

where  $M_w$  is the formula weight of the dopant used in grams per mole,  $M$  is the mass of dopant in grams, and  $V$  is the volume of the resin-dopant mixture in cubic centimeters.

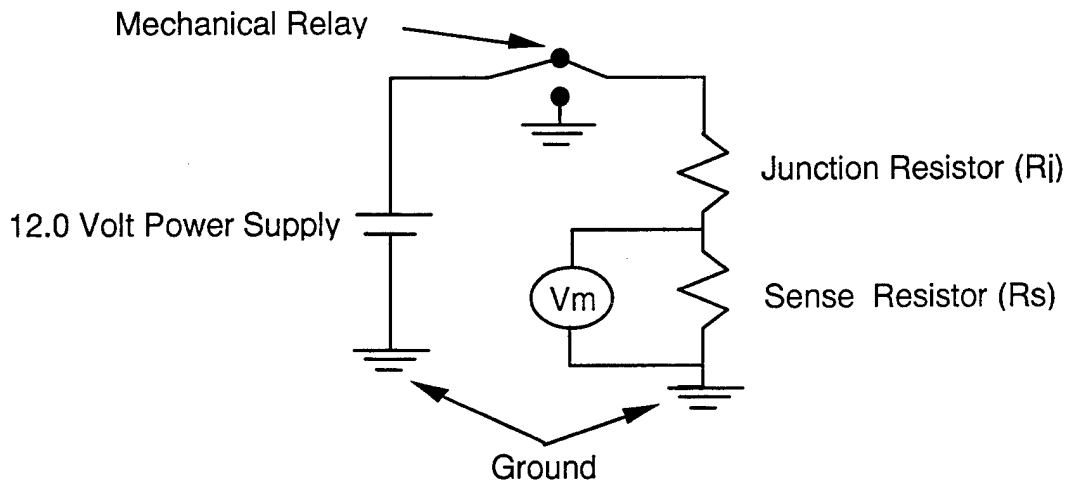
The hydrodynamic radius of tetrabutylammonium and acetate ions can be calculated using equations (2) through (7) and the concept of limiting ionic conductance. The hydrodynamic radius of tetrabutylammonium and acetate ions was calculated to be 5.5 and 3.75 Å, respectively.

### 3. Experimental Procedures

In the following sections, the basic components and operation of a SMARTweave DC-sensing system are reviewed. The experimental apparatus and procedures designed to

investigate the effects of resin chemistry on ionic conductivity are provided. In the last section is a description of the down-selection methodology used to determine the primary candidate dopant.

**3.1 SMARTweave System Components and Operation.** SMARTweave is a patented [1] sensor system that measures and tracks the DC conductance of a resin as it flows into an RTM mold and cures. This is done through a noncontacting grid of wires; one set serves as excitation leads and an orthogonal set in a parallel plane serves as sensing leads. Figure 2 shows a circuit diagram for a single-node voltage experiment. The resin acts as a resistor designated as  $R_j$ . Under an applied voltage, current is induced in a circuit containing a second resistor ( $R_s$ ) of known resistance. The sense resistor,  $R_s$ , has a fixed resistance, which is the same order of magnitude of the resin resistance ( $R_j$ ).



**Figure 2. SMARTweave Single-Node Circuit Schematic.**

The SMARTweave system used in this study consists of a National Instruments SCXI interface chassis (where the excitation and sense leads are connected), a National Instruments multiplexer (for switching from one set of leads to another), and a computer (for data display and storage). A 12-V power supply provides a DC voltage to the excitation leads. Only one excitation lead is active at any time. The multiplexer sends out a voltage to the excitation leads,

and the SCXI chassis monitors the sense leads for an induced current. The induced current is detected as a voltage across  $R_s$ .

During a single-node test, a flat 12-V excitation voltage remains across a single excitation lead. In the presence of a conductive medium, such as a VE resin, a current is induced in the sense lead and a voltage is created across  $R_s$ . Changes in  $R_j(t)$  are then recorded as changes in  $V_m(t)$  by the SMARTweave Labview software.

For the single-node experiments performed in this study, a 12-V applied voltage and a 10-M $\Omega$  sense resistor were used. The measured voltage,  $V_m(t)$ , and sense resistance can be used to calculate the junction resistance,  $R_j(t)$ , by

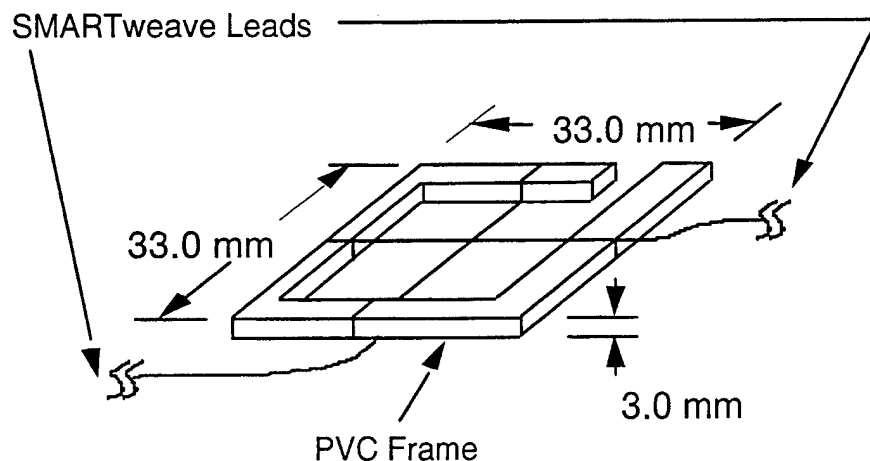
$$R_j(t) = \left( \frac{12 \text{ V}}{V_m(t)} \right) \cdot R_s - R_s, \quad (9)$$

where  $V_m(t)$  is in volts and  $R_s$  is in ohms.

Figure 3 is the schematic of a single-node test cell (SNTC). A SNTC consists of a sense and excitation lead that are made of stainless steel wire and attached to a box frame made of fiber-reinforced PVC. SNTC apparatus were designed to hold the geometric parameters,  $L$  and  $A$ , constant so that the material parameters could be studied.

**3.2 Effects of Resin Chemistry on Ionic Conductance.** SMARTweave experiments using SNTC apparatus were performed to study the effects of CoNap and Trigonox 239A on the conductance of VE resin. VE 411-C-50 resin samples were prepared by first adding the desired concentration of CoNap, then adding the desired concentration of Trigonox 239A, and mixing thoroughly. Once the accelerator was added into the VE-CoNap mixture, the specimen was poured into a SNTC and the SMARTweave voltage was monitored.

In the first series of experiments, the weight-percentage concentration of CoNap was varied from 0.22 wt% to 0.35 wt%, with a total resin mass of 50.0 g. The weight-percentage



**Figure 3. SNTC.**

concentration of Trigonox 239A was held constant at approximately 2.0 wt%. In the second series of experiments, the weight-percentage concentration of Trigonox 239A was varied from 2.0 wt% to 3.5 wt%, with a total resin mass of 50.0 g. The weight-percentage concentration of CoNap was held constant at approximately 0.2 wt%.

**3.3 Dopant Down-Selection and Characterization.** The following section is broken into two parts: (1) dopant down-selection and (2) dopant-resin characterization. The first section describes the methodology used to determine the primary candidate dopant. The second section describes the experimental apparatus and procedures for the characterization of (1) the effects of doping on the viscosity of VE resin and (2) the effects of doping on the reaction kinetics of VE resin.

**3.3.1 Dopant Down-Selection.** The first priority of this investigation was to determine a suitable dopant for VE resin. Sodium acetate, sodium bisulfate, sodium salt, tetrabutylammonium acetate (TA), tetrabutylammonium hydroxide (TH), and tetrabutylammonium iodide (TI) were added to the VE resin system, and the voltage profile during cure was measured. A SNTC configuration was used to measure the SMARTweave voltage vs. time response of the curing candidate dopant and VE resin mixtures.

The effects of doping VE with the primary candidate dopant were then studied by varying the weight-percentage concentration of dopant from 0.025 wt% to 0.1 wt% with a total resin mass of 50.0 g. The weight-percentage concentrations of CoNap and Trigonox 239A were held constant at 0.2 wt% and 2.0 wt%, respectively.

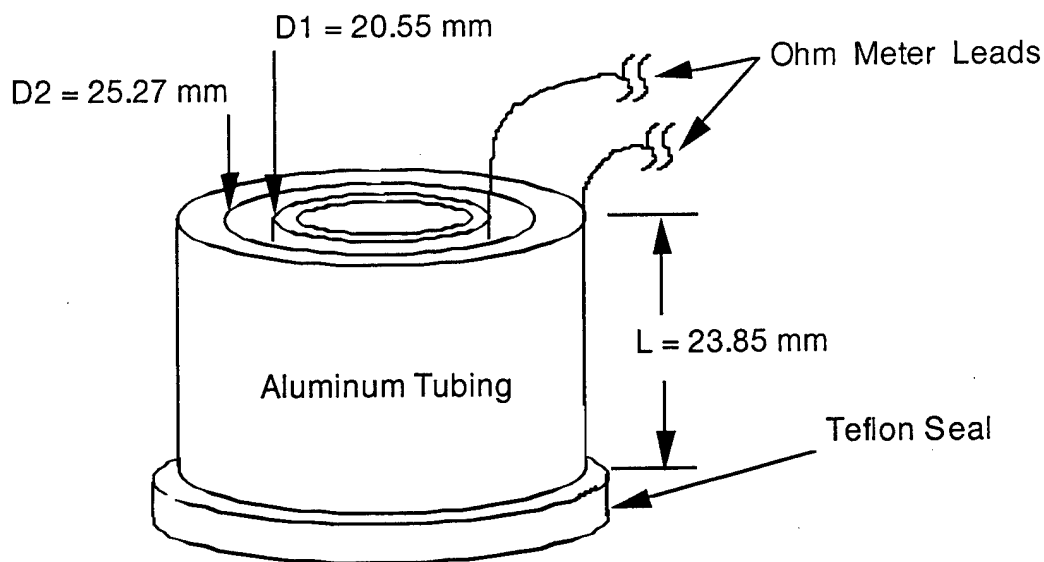
Two panels, one with dopant added and one without, were manufactured using Seemann Composite Resin Infusing Molding Process (SCRIMP) manufacturing and monitored with SMARTweave process at room temperature. This was done to determine the effects of doping with the primary candidate dopant on the ionic conductivity and mechanical properties manufactured VE composite part. No post-curing was performed. Each part consisted of an identical lay-up of six layers of 5×4 24-oz E-glass fabric, cut into roughly 12-in squares. Stainless steel wire sensor leads were used to monitor the SMARTweave voltage of the curing part.

The nondoped resin plate consisted of 2.0-wt% Trigonox 239A, and 0.2-wt% CoNap in VE. The doped resin plate consisted of 0.1-wt% dopant, 2.0-wt% Trigonox 239A, and 0.2-wt% CoNap in VE. Short-beam shear and open-hole compression, A-695, specimens were cut from each panel and tested. Short-beam shear tests were conducted in accordance with American Society for Testing of Materials (ASTM) test standard D2344.

**3.3.2 Characterization.** The resistance of a doped VE resin sample was monitored over the period of 18 hr to determine the amount of time needed to reach the equilibrium concentration of ionized dopant. The sample consisted of 0.1-wt% dopant mixed, only partially, with VE; no initiator or accelerator was added.

The resistance of VE doped with 0.05–4.8-wt% dopant was measured using a cocylindrical DC conductivity cell and a Fluke multimeter. The DC conductivity cell design was constructed by following the ASTM -test standard D257-78. Samples with the aforementioned concentrations were then prepared and shelved until an equilibrium concentration of ions was reached. A DC cell was then filled with one sample at a time and used to measure the resistivity

of the resin. The measured resistivity was then used along with equations (3) through (7) to determine the ionic concentrations. Figure 4 shows the shape and dimensions of the DC cell used in this experiment.



**Figure 4. DC Cell Configuration.**

The viscosity of both a nondoped and doped curing VE resin was measured using a Brookfield Viscometer and Small Sample Adapter, which was capable of regulating temperature via water jacket and circulating water bath. The temperature was held constant at  $30 \text{ }^\circ\text{C}$ . The doped VE resin system consisted of 0.1-wt% dopant, 2.0-wt% CoNap, and 0.2-wt% Trigonox 239A.

T-FTIR spectroscopy is a characterization method that can be used to determine the degree of conversion of VE and ST monomers of a curing VE resin system [9]. By measuring the degree of conversion of the individual monomers, the effects of doping, if any, on the reaction kinetics of VE resin can be determined.

Degree of conversion experiments were performed on a Nicolet 20DXB Fourier transform infrared (FTIR) spectrometer in transmission mode. T-FTIR experiments were performed at 30, 40, and 50 °C. Specimen temperature was controlled by a set of heater cartridges which are embedded within the specimen holder.

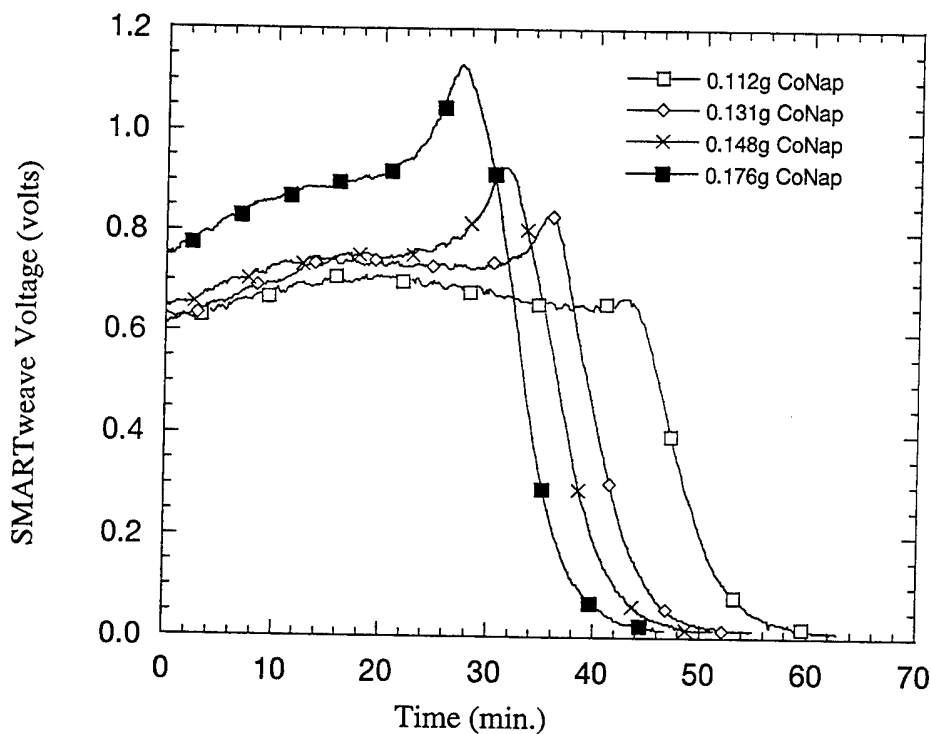
## 4. Results and Discussion

The following section reports the effects of resin chemistry on the ionic conductivity of VE resin. The purpose of these experiments was to characterize the sensitivity of ionic conductivity to variations in resin chemistry and to determine the viability of using different component concentration to enable DC sensing. For the recommended concentrations of initiator, Trigonox 239A at 2.0 wt%, and accelerator, CoNap at 0.2 wt%, the initial SMARTweave voltage is 0.6 V with a 60-min duration of measurable conductivity.

Through doping, the initial SMARTweave voltage can be increased to over 2.5 V. The duration of measurable ionic conductivity remains unaffected; however, the sight-to-noise (S/N) ratio is greatly increased, which increases the resolution of DC sensing and enables the in-situ determination of gelation and possible cure to greater extents of reaction.

The effects of resin chemistry on ionic conductivity and the results of the dopant down-selection studies are presented. The latter sections report the effects of doping on the initial SMARTweave voltage, mechanical properties, viscosity, and reaction kinetics of VE resin.

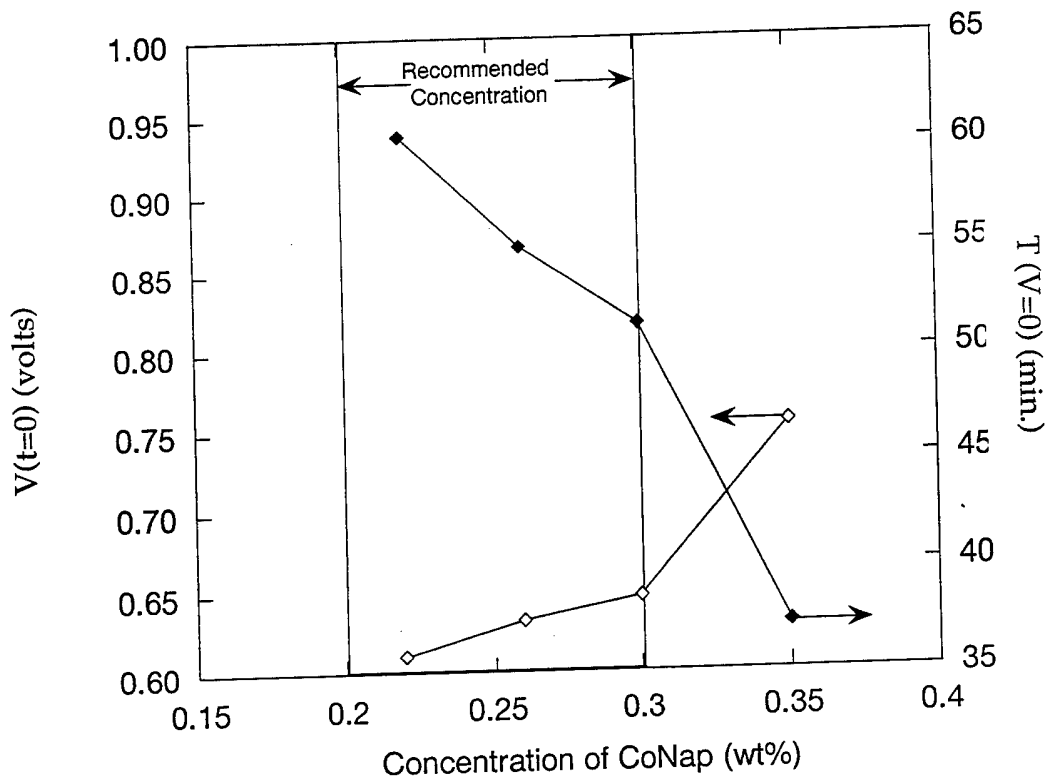
**4.1 Effects of Resin Constituents on Ionic Conductance.** Figure 5 shows SMARTweave voltage vs. time for variable concentrations of CoNap. There is a slight increase in voltage with increasing weight-percentage concentrations of CoNap. The increased peak voltage is the result of faster reaction kinetics and higher exothermic temperatures that lead to lower resin viscosity and increased conductance.



**Figure 5. Effect of Variable Concentrations of CoNap on Ionic Conductance. Markers Do Not Represent All Data Points Taken. All Data Points Fall on Lines Connecting Markers.**

For these experiments, the resin starts to cure the instant that all of the components have been mixed together. The increase in voltage up to the point at which the exotherm occurs is the result of heat released by the reaction. The reacting polymer system reacts as a polymer electrolyte up to the start of gelation. This can be seen in the rise of ionic conductivity with increasing heat of reaction.

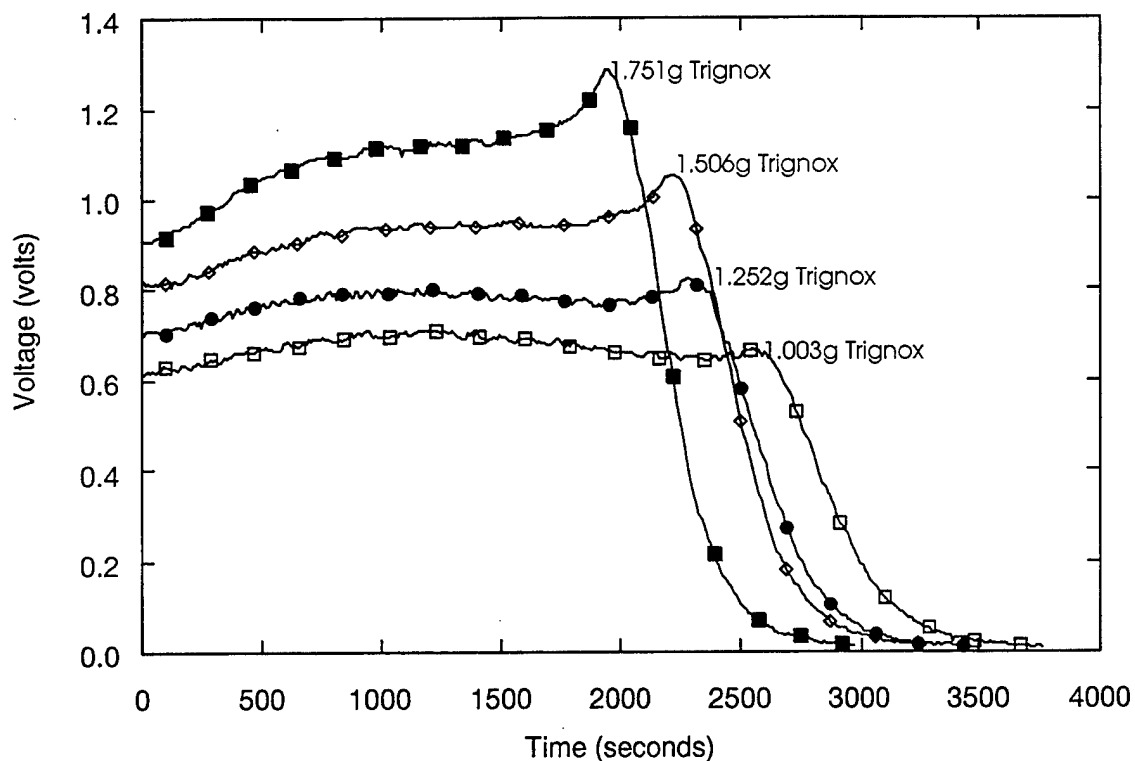
Figure 6 shows the change in initial SMARTweave voltage ( $V(t = 0)$ ) and the time at which voltage goes to zero ( $t(V = 0)$ ) with increasing concentration of CoNap. The slight increase in  $V(t = 0)$  with increasing concentrations of CoNap proves that CoNap adds only a small percentage of impurity ions to the resin system.



**Figure 6. Initial SMARTweave Voltage vs. Concentration of CoNap. Data Points Are Connected by Lines.**

In the recommended region of CoNap concentration,  $V(t = 0)$  is a linear function of concentration. A linear fit to that region yields a line with a slope of 0.46 V/wt%. The slight increase in initial voltage comes at the cost of over a 20-min decrease in period of measurably ionic conductivity. The decrease in  $t(V = 0)$  is the result of accelerated reaction kinetics, which are dependent not only on the concentration of initiator (Trigonox 239A) but on the concentration of accelerator as well (CoNap). This makes the addition of more CoNap to the system an unacceptable way of increasing ionic conductivity.

Figure 7 shows the change in voltage as a function of time for variable concentrations of Trigonox 239A. There is a notable increase in initial voltage with increasing weight-percentage concentrations of Trigonox 239A. The increased peak voltage is the result of faster reaction

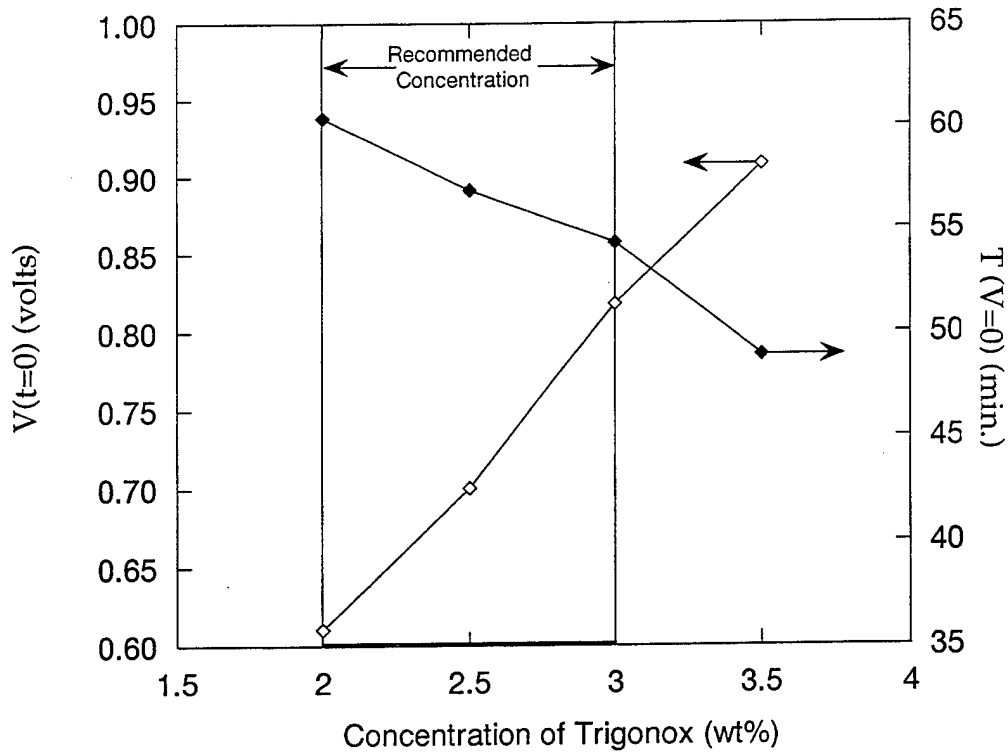


**Figure 7. SMARTweave Voltage vs. Time for Variable Concentrations of Trigonox 239A. Markers Do Not Represent All Data Points Taken. All Data Points Fall on Lines Connecting Markers.**

kinetics and higher exothermic temperatures that lead to lower resin viscosity and increased ionic conductance.

Figure 8 shows the change in initial voltage ( $V(t = 0)$ ) and the time at which the voltage goes to zero ( $t(V = 0)$ ) with increasing concentration of Trigonox 239A. The increase in  $V(t = 0)$  with increasing concentrations of Trigonox 239A proves that the initiator adds a significant percentage of impurity ions to the resin system.

In the recommended region of Trigonox 239A concentration,  $V(t = 0)$  is a linear function of concentration. A linear fit to that regions yields a line with a slope of 0.21 V/wt%. The increase in initial voltage, however, comes at the cost of a significant decrease in the period of



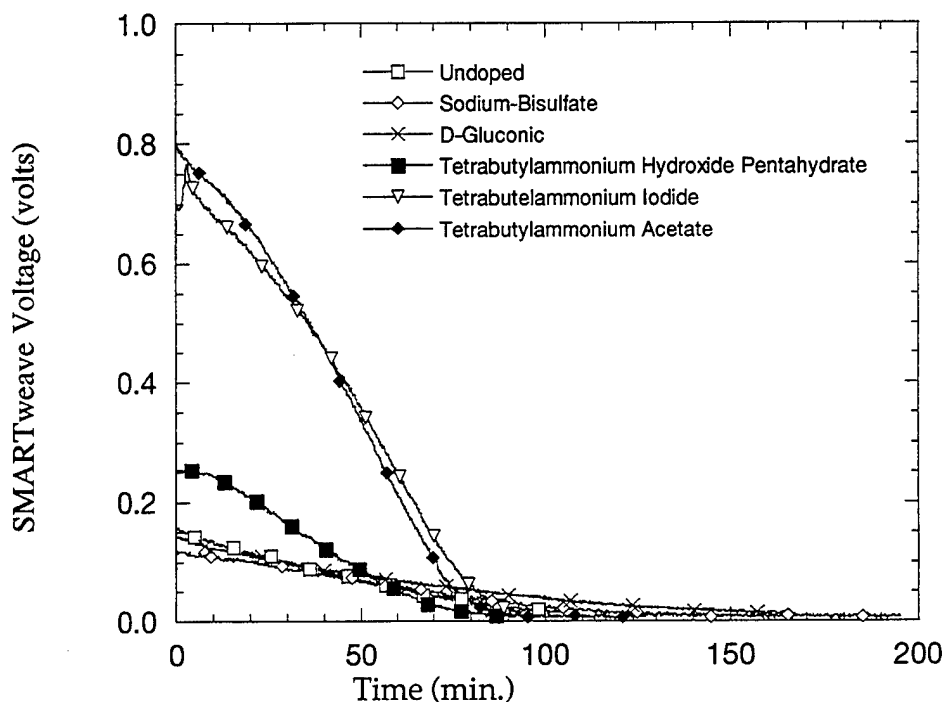
**Figure 8. Initial SMARTweave Voltage vs. Concentration of Trigonox 239A. Data Points Are Connected by Lines. Line of Linear Curve Fit for Recommended Region Is Not Shown.**

measurably ionic conductivity. The drastic decrease in  $t(V = 0)$  makes the addition of more Trigonox 239A to the system an undesirable way of increasing ionic conductivity. The decrease in  $t(V = 0)$  is the result of accelerated reaction kinetics, which are dependent on both the concentration of accelerator (CoNap) and on the concentration of initiator (Trigonox 239A).

From a processing perspective, accelerated cure kinetics and reduced time to gelation are not desirable. This is mainly due to the finite amount of time needed for resin infusion and the detrimental effects increased heats of reaction may have on the mechanical properties of a manufactured part.

**4.2 Dopant Down-Selection and Characterization.** The following sections provide the results of the dopant down-selection and characterization of the primary candidate dopant, including the effects of doping on ionic conductivity, viscosity, and reaction kinetics of VE resin.

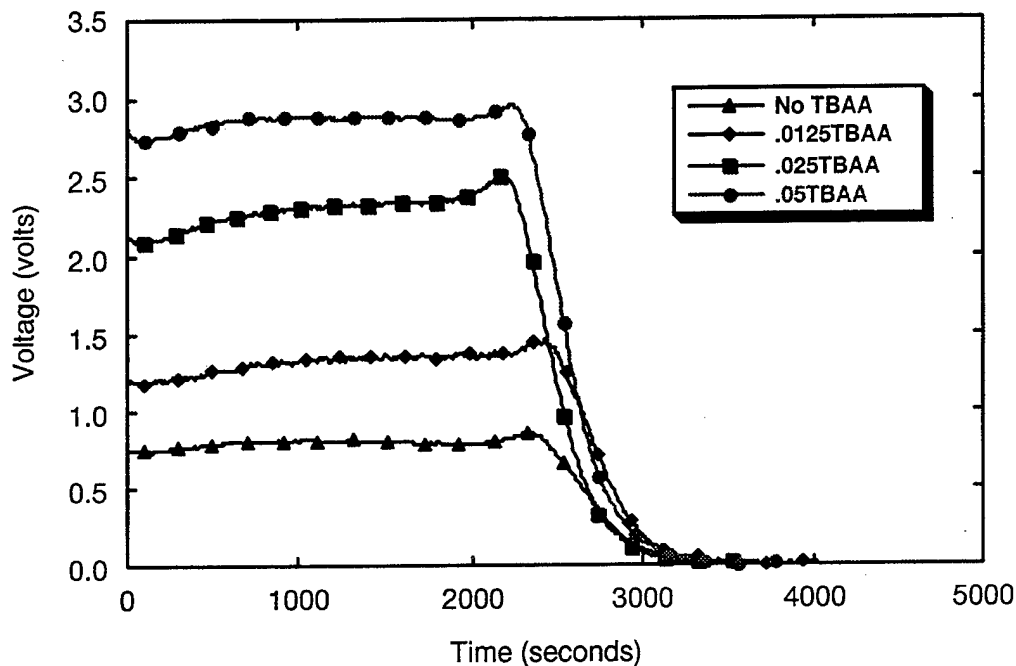
**4.2.1 Dopant Down-Selection.** Figure 9 shows the effects of the various candidate dopants on the ionic conductivity on curing VE. Sodium acetate is not shown in Figure 9 because it caused immediate cross-linking of the VE system. Therefore, sodium acetate could not be monitored with a SMARTweave system. The sodium bisulfate and sodium salt additives showed a low solubility in the VE system, which explains the low increase in voltage signal. The tetrabutylammonium ion pairs all showed an ability to partially ionize in the VE system. The TH- and TI-doped VE systems showed a lower increase in conductivity than the TA-doped VE system. As a result of its ability to increase the conductivity of VE resin without any signs of adversely affecting cure, TA was chosen as the primary candidate dopant for continued investigation.



**Figure 9. SMARTweave Voltage vs. Time for Candidate Dopants. Markers Do Not Represent All Data Points Taken. All Data Points Fall on Lines Connecting Markers.**

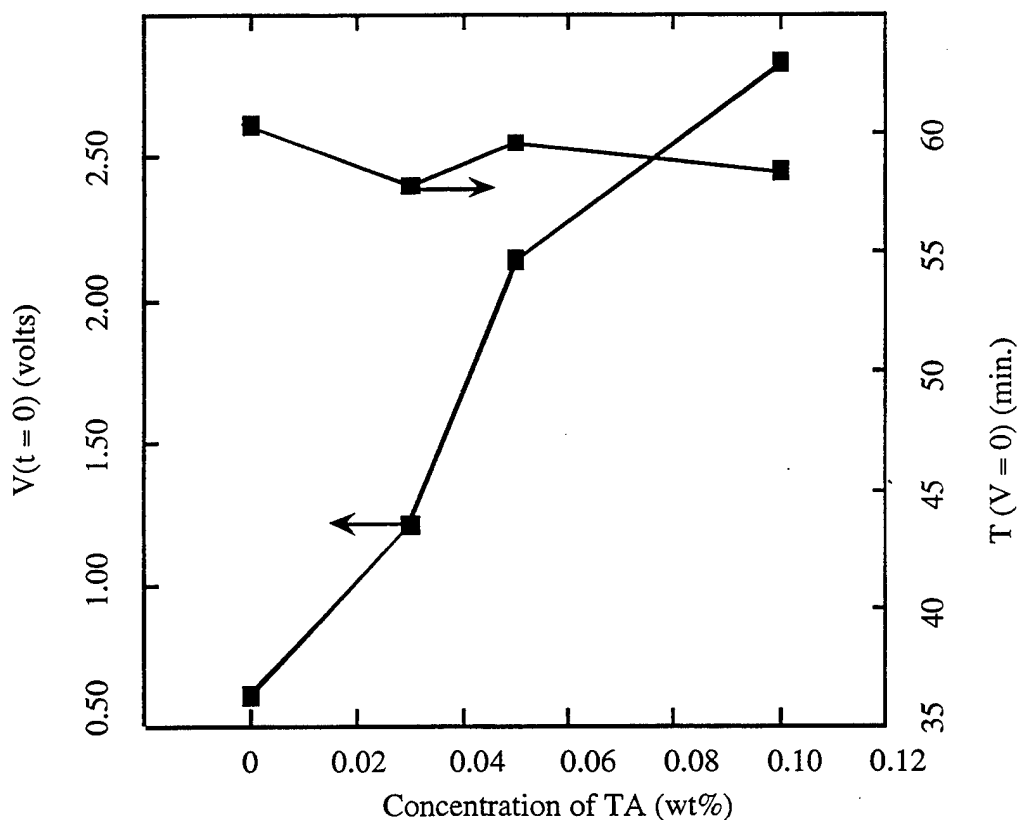
## 4.2.2 Characterization of TA-VE Resin System.

4.2.2.1 *Effects of Doping on Ionic Conductivity.* Figure 10 shows the effects of increased concentration of TA on ionic conductivity. This figure clearly shows that increasing the concentration of TA raises ionic conductivity, but does not adversely affect the SMARTweave voltage profile of the curing VE resin system. In other words, whereas increased concentrations of CoNap and Trigonox 239A caused exotherms and decreased periods of measurable voltage, TA showed no such effects.



**Figure 10. Effect of Variable Concentration of TA on SMARTweave Voltage. Markers Do Not Represent All Data Points Taken. All Data Points Fall on Lines Connecting Markers.**

Figure 11 shows the change in initial SMARTweave voltage ( $V(t = 0)$ ) and the time at which SMARTweave voltage goes to zero ( $t(V = 0)$ ) as a function of weight-percent concentration of TA. The increase in  $V(t = 0)$  with increasing concentrations of TA prove that TA adds a significant percentage of impurity ions to the resin system.

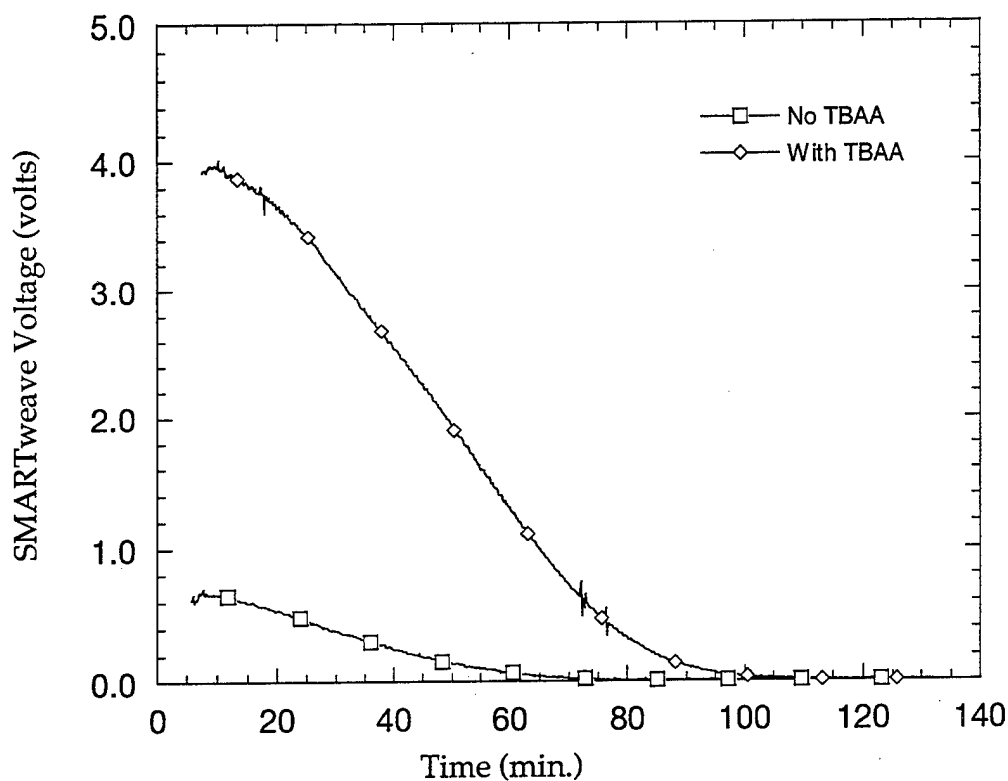


**Figure 11. Initial SMARTweave Voltage vs. Concentration of TA. Data Points Are Connected by Lines.**

For all TA concentrations tested,  $V(t = 0)$  is a linear function of weight-percent concentration. A linear fit to those regions yields a line with a slope of 22.4 V/wt%. Note, that this is an order of magnitude higher than CoNap and Trigonox 239A. Ionic conductivity can now be adjusted to the level needed for multiplex sensing by simply adding more dopant.

The increase in initial voltage comes with no significant change in the period of measurably ionic conductivity. The ability of TA to substantially increase the ionic conductivity of a VE resin without decreasing  $t(V = 0)$ , unlike Trigonox 23A and CoNap, makes it a viable means for enabling the multiplex DC sensing of high-resistivity resins.

4.2.2.2 *Effects of Doping on the DC Sensing and Mechanical Properties of Manufactured Composite Panel.* Figure 12 shows the SMARTweave voltage profile for a doped and nondoped VE panel, 12 × 12 square-inch 5 × 4 24-oz glass preform, during and after infusion. This figure shows that doping with TA greatly increases the S/N ratio of SMARTweave in a manufacturing environment, showing the viability of scale up. The increase in S/N ratio allows for faster cycle times and improved multiplex sensing of large parts with multiple nodes. In multiple node SMARTweave systems, where multiplexing cycle time is optimized, the noise in the system will increase significantly, necessitating the higher S/N ratio that can be achieved via doping.



**Figure 12. SMARTweave Voltage vs. Time in a SCRIMP Environment. Markers Do Not Represent All Data Points Taken. All Data Points Fall on Lines Connecting Markers.**

Table 1 shows the results of the short-beam shear and open-hole compression tests. The panel that consisted of TA-doped VE resin showed a slight improvement in the average apparent

**Table 1. Short-Beam Shear and Open-Hole Compression Test Results**

Panel Samples	Apparent Compressive Strength (MPa)	Apparent Shear Strength (MPa)
Nondoped	219.2 ± 34.3	33.7 ± 0.7
TA-Doped	283.5 ± 39.8	40.9 ± 2.9

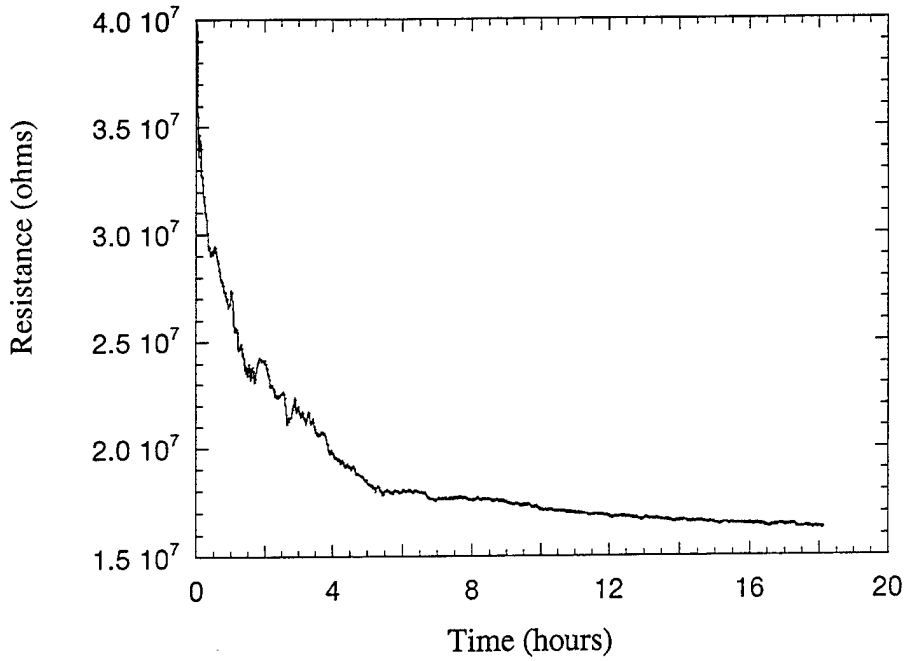
shear and compressive strength over that of the nondoped panel. The average apparent shear strength for the TA-doped specimen was 41 MPa, and 34 MPa for the nondoped specimens. The average apparent compressive strength of the TA-doped specimen was 284 MPa, and 219 MPa for the nondoped specimens. This shows that the addition of TA to VE resin not only affords a higher S/N ratio and decreases equipment cycle times but also does not adversely affect the mechanical properties of the part. Results in Table 1 show that doping may improve properties, but additional mechanical testing is required.

*4.2.2.3 Determination of Dopant Ionization Constant and Equilibrium Concentration.*

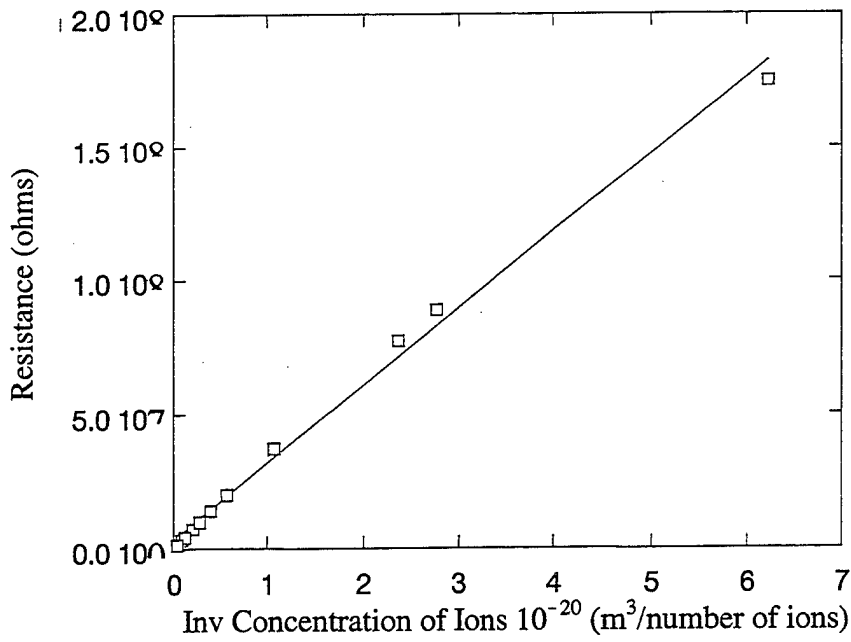
Figure 13 shows the time it takes for TA-doped VE resin to reach ionic equilibrium concentration. As can be seen from Figure 13, 0.1-wt% TA in VE should be allowed to sit for at least 15 hr before being tested. However, it should be kept in mind that prepared samples are thoroughly mixed before shelving, which decreases the time needed for ionic equilibrium concentration to be reached.

Figure 14 shows the change of resistance with changes in the inverse concentration of ions. The inverse concentration of ions was determined with the use of equations (3) through (7), where the maximum theoretical molar ionic conductivity ( $\Lambda_{\max}$ ) for TA is  $65.2 \times 10^{-4} \text{ S}\cdot\text{m}^2/\text{mol}$ , and the formula weight ( $M_w$ ) is 301.25 g/mol.

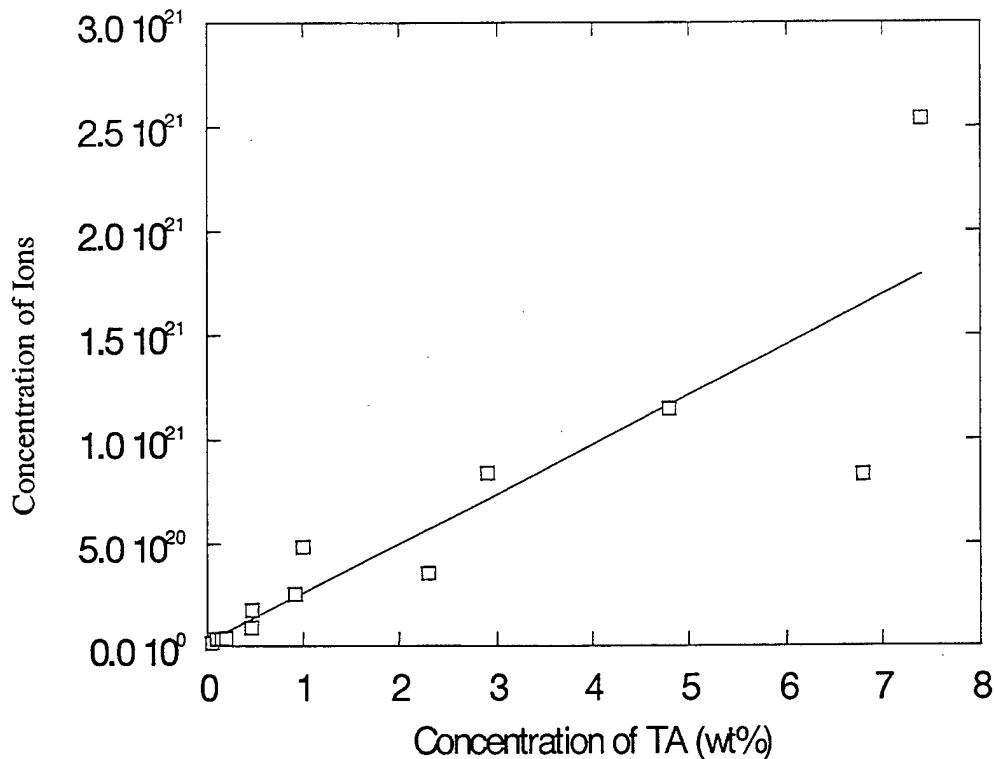
Figure 15 shows the concentration of ions vs. the weight-percent of TA added to VE. As the concentration of TA increases, so does the concentration of ions that ionize in solution with VE. According to these results, the trend is fairly linear and yields a fit with an intercept of  $2.0 \times 10^{19}$  ions and a slope of  $2.4 \times 10^{20} \text{ ions}/\text{m}^3 \text{ wt}\%$ . With this known, one can tailor the conductivity of VE resin by simply adding in the appropriate amount of TA to yield the desired amount of ions.



**Figure 13. Resistance vs. Time for Equilibrium Concentration Study.**



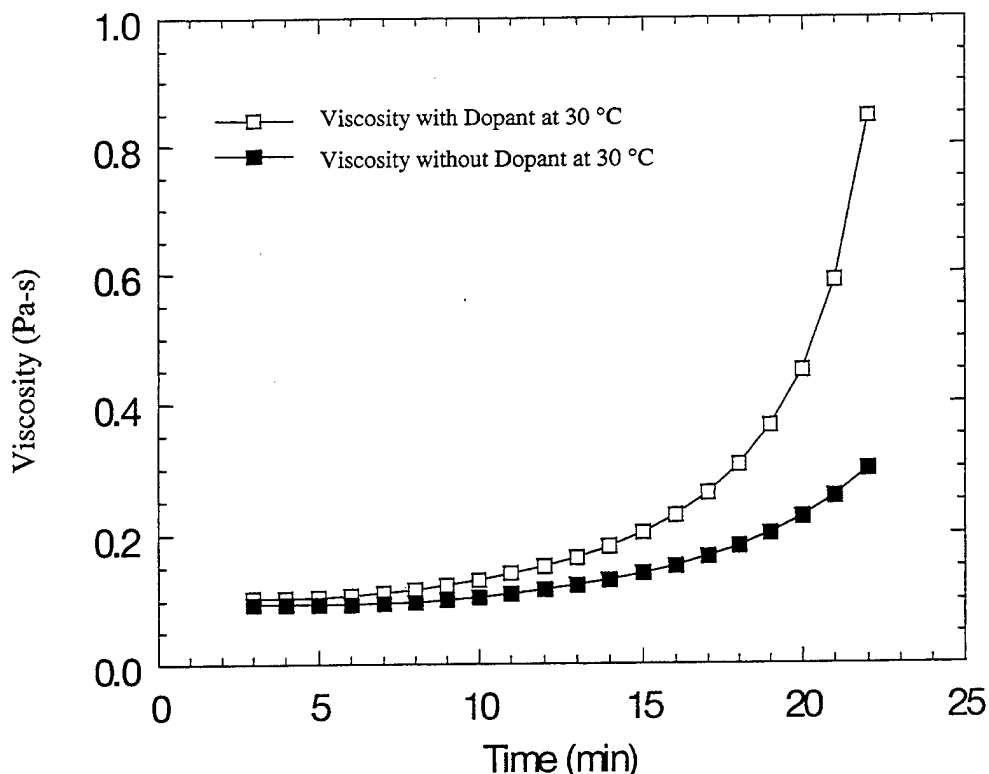
**Figure 14. Conductivity vs. Inverse Concentration of Ions. Data Points Are Shown, Along With a Linear Curve Fit.**



**Figure 15. Concentration of TA Ions vs. Mass Concentration of TA. Data Points Are Shown, Along With a Linear Curve Fit.**

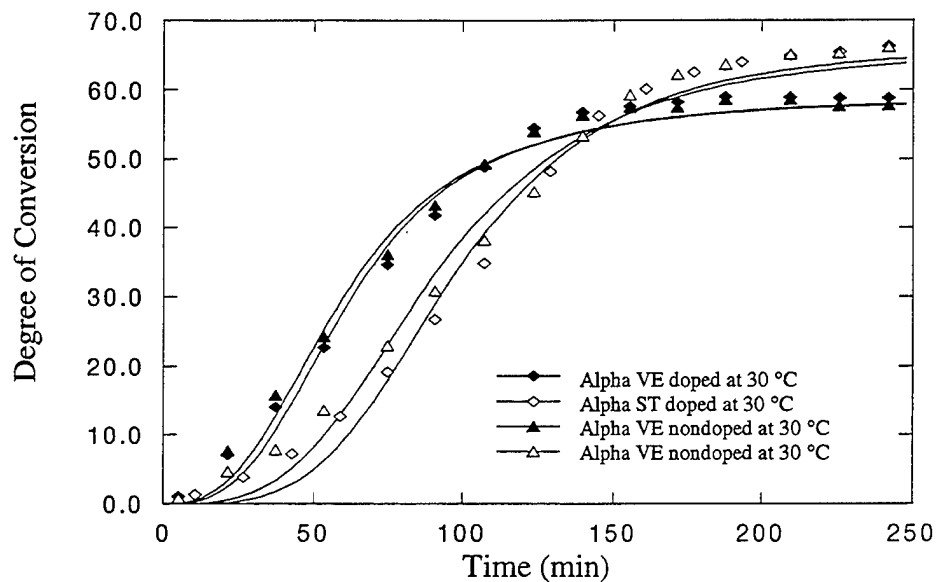
*4.2.2.4 Effects of TA on the Viscosity and Reaction Kinetics of Curing VE Resin.* Figure 16 shows a comparison of a TA-doped and nondoped VE resin at 30 °C. As can be seen from Figure 16, TA seems to have an accelerating affect on the viscosity of curing VE resin at 30 °C. This may be the result of TA ions forming complexes with the ends of the VE monomer. Complex formation was also seen when sodium acetate was added to VE. In the case of TA, the formation of complexes may not be as extensive as it was in the case of sodium acetate, which would result in the ability of TA to raise conductivity without adversely affecting the mechanical properties of the cured resin system. However, the formation of complexes could cause the apparent viscosity to increase more rapidly than seen in the nondoped VE system.

Figures 1 through 19 show the degree of conversion of both the VE and ST monomers for the doped and nondoped systems at isothermal cure temperatures of 30, 40, and 50 °C.

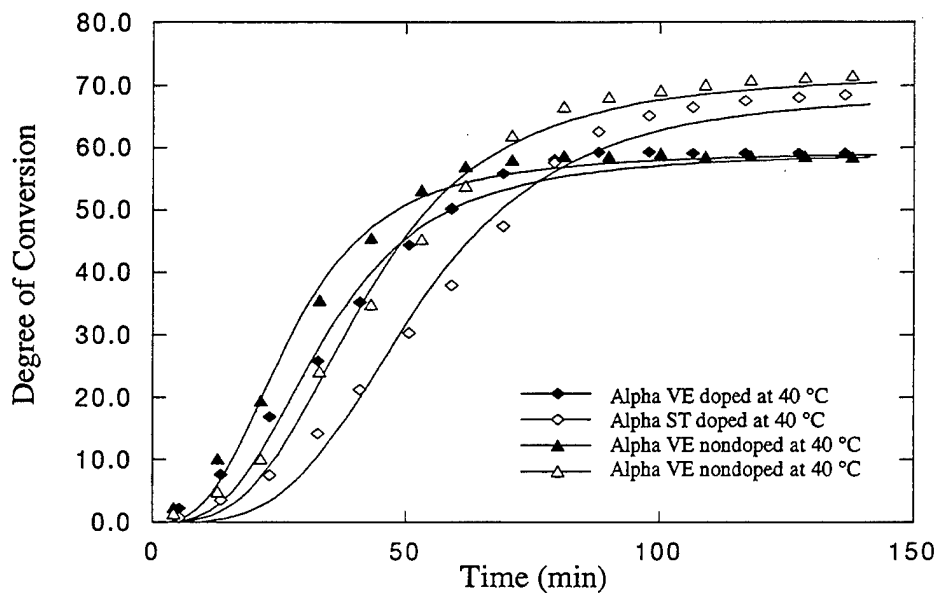


**Figure 16. Effect of TA on Viscosity of Curing Doped 411-C-50 Resin. Data Points Shown Are With Lines.**

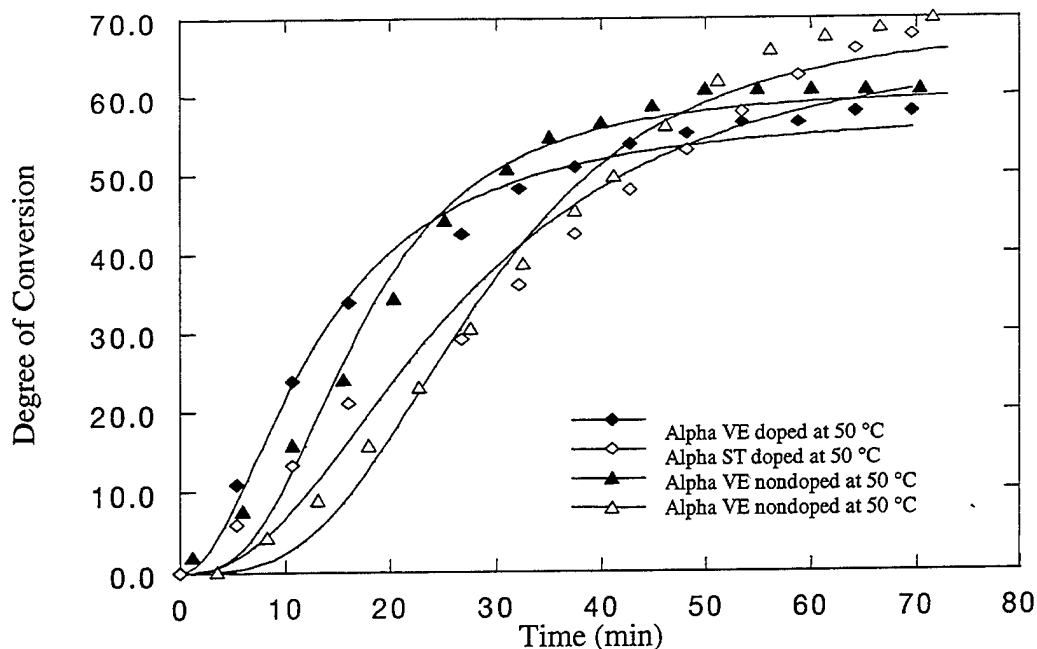
Figures 17 through 19 also show that TA has no noticeable effects on the reaction kinetics of VE resin. This is consistent with the findings that the addition of TA to VE resin did not influence  $V(t = 0)$ . However, TA was found to increase the rate at which the viscosity of a curing VE resin increases. The period preceding the start of gelation is very short, less than 25 min at a cure temperature of 30 °C. The difference in times for the TA doped and nondoped resin to start gelling at 30 °C was less than 5 min. For T-FTIR tests at 30 °C, the time between measurements was 5 min. Therefore, it is completely possible that if TA does influence the reaction kinetics of VE resin before gel, these effects are small enough to go unnoticed in the experiments previously performed.



**Figure 17. Degree of Conversion of VE and ST at 30 °C. Data Are Obtained Using T-FTIR. Markers Do Not Represent All Data Points Taken. Autocatalytic Curve Fit Is Shown as Solid Line.**



**Figure 18. Degree of Conversion of VE and ST at 40 °C. Data Are Obtained Using T-FTIR. Markers Do Not Represent All Data Points Taken. Autocatalytic Curve Fit Is Shown as Solid Line.**



**Figure 19. Degree of Conversion of VE and ST at 50 °C. Data Are Obtained Using T-FTIR. Markers Do Not Represent All Data Points Taken. Autocatalytic Curve Fit Is Shown as Solid Line.**

## 5. Conclusions

The viability of using organic dopants to lower the resistivity of low-conductivity resins has been proven. TA and other tetrabutylammonium group ions have the ability to significantly lower the resistivity of VE resin without adversely affecting the cure behavior and mechanical properties of a manufactured composite part.

TA has the ability to increase the ionic conductivity of VE resins without shortening the duration of DC sensing. This investigation successfully characterized the ionization constant and concentration of TA in VE resin. TA was found to increase the rate at which the viscosity of a curing VE resin increases, without measurably affecting the degree of conversion of either VE or the ST monomers.

Another benefit of doping VE with TA is that it may enable the in-situ simultaneous measurement of ionic conductivity and degree of conversion of VE and ST monomers. This can be done through a modified SNTC, which can be embedded into a T-FTIR crystal. Through simultaneous measurements of degree of conversion and ionic conductance, the relationship between the electrical properties of a reacting polymer and reaction kinetics after gelation can be determined.

Doping VE resin with an organic dopant was proven as a viable method for lowering the resistance of high-resistivity resins. This investigation proved that doping enables the multiplex sensing of potentially thousands of point sensors using DC-sensing techniques such as SMARTweave.

INTENTIONALLY LEFT BLANK.

## 6. References

1. Walsh, S. M. "In-Situ Sensor Method and Device." U.S. Patent No. 5,210,499, 11 May 1993.
2. Don R. C., K. R. Bernetich, B. K. Fink, M. Louderback, and J. W. Gillespie, Jr., "Large-Scale Implementation of Flow and Cure Sensing in a Thermoset Resin Infused Composite Structure," 43rd International SAMPE Symposium and Exhibition, Anaheim, CA, 1998.
3. Fink, B. K., S. M. Walsh, D. C. DeSchepper, J. W. Gillespie, Jr., R. L. McCullough, R. C. Don, and B. J. Waibel. "Advances in Resin Transfer Molding Flow Monitoring Using SMARTweave Sensors." *Proceedings of the ASME Materials Division*, MD-vol. 69.2, 1995 International Mechanical Engineering Conference and Exposition, pp. 999-1015, 1995.
4. Fink, B. K., S. M. Walsh, D. C. DeSchepper, J. Kleinmeyer, S. Bickerton, and R. C. Don. "Development of a Two-Sided Wiring Scheme for Resin Transfer Molding Flow Monitoring Using SMARTweave Sensor." CCM Technical Report No. 95-08, 1995.
5. Schwab, S. D., R. L. Levy, and G. G. Glover. "Sensor System for Monitoring Impregnation and Cure During Resin Transfer Molding." *Polymer Composites*, vol. 17, no. 2, pp. 312-316, April 1996.
6. Kleitz, M., J. Million-Brodaz, and P. Fabry. "New Compounds for Isfets." *Solid State Ionics*. Vol. 22, Issue 4, pp. 295-303, February 1987.
7. Steele, B. C. H. *Solid State Ionics*. Vol. 12, p. 391, 1984.
8. Burgess, J. *Ions in Solution: Basic Principles of Chemical Interactions*. New York: Halsted Press, 1988.
9. Brill, R. P., R. L. McCullough, and G. R. Palmese. *Proceedings of 11th Technical Conference of ASC*, 1996.

INTENTIONALLY LEFT BLANK.

NO. OF  
COPIES    ORGANIZATION

2    DEFENSE TECHNICAL  
INFORMATION CENTER  
DTIC DDA  
8725 JOHN J KINGMAN RD  
STE 0944  
FT BELVOIR VA 22060-6218

1    HQDA  
DAMO FDT  
400 ARMY PENTAGON  
WASHINGTON DC 20310-0460

1    OSD  
OUSD(A&T)/ODDDR&E(R)  
R J TREW  
THE PENTAGON  
WASHINGTON DC 20301-7100

1    DPTY CG FOR RDA  
US ARMY MATERIEL CMD  
AMCRDA  
5001 EISENHOWER AVE  
ALEXANDRIA VA 22333-0001

1    INST FOR ADVNCD TCHNLGY  
THE UNIV OF TEXAS AT AUSTIN  
PO BOX 202797  
AUSTIN TX 78720-2797

1    DARPA  
B KASPAR  
3701 N FAIRFAX DR  
ARLINGTON VA 22203-1714

1    NAVAL SURFACE WARFARE CTR  
CODE B07 J PENNELLA  
17320 DAHLGREN RD  
BLDG 1470 RM 1101  
DAHLGREN VA 22448-5100

1    US MILITARY ACADEMY  
MATH SCI CTR OF EXCELLENCE  
DEPT OF MATHEMATICAL SCI  
MADN MATH  
THAYER HALL  
WEST POINT NY 10996-1786

NO. OF  
COPIES    ORGANIZATION

1    DIRECTOR  
US ARMY RESEARCH LAB  
AMSRL D  
D R SMITH  
2800 POWDER MILL RD  
ADELPHI MD 20783-1197

1    DIRECTOR  
US ARMY RESEARCH LAB  
AMSRL DD  
2800 POWDER MILL RD  
ADELPHI MD 20783-1197

1    DIRECTOR  
US ARMY RESEARCH LAB  
AMSRL CS AS (RECORDS MGMT)  
2800 POWDER MILL RD  
ADELPHI MD 20783-1145

3    DIRECTOR  
US ARMY RESEARCH LAB  
AMSRL CI LL  
2800 POWDER MILL RD  
ADELPHI MD 20783-1145

ABERDEEN PROVING GROUND

4    DIR USARL  
AMSRL CI LP (BLDG 305)

<u>NO. OF COPIES</u>	<u>ORGANIZATION</u>	<u>NO. OF COPIES</u>	<u>ORGANIZATION</u>
1	DIRECTOR US ARMY RESEARCH LAB AMSRL CP CA D SNIDER 2800 POWDER MILL RD ADELPHI MD 20783-1145	1	COMMANDER US ARMY MATERIEL CMD AMXMI INT 5001 EISENHOWER AVE ALEXANDRIA VA 22333-0001
1	DIRECTOR US ARMY RESEARCH LAB AMSRL OP SD TA 2800 POWDER MILL ROAD ADELPHI MD 20783-1145	2	COMMANDER US ARMY ARDEC AMSTA AR AE WW E BAKER J PEARSON PICATINNY ARSENAL NJ 07806-5000
3	DIRECTOR US ARMY RESEARCH LAB AMSRL OP SD TL 2800 POWDER MILL ROAD ADELPHI MD 20783-1145	1	COMMANDER US ARMY ARDEC AMSTA AR TD C SPINELLI PICATINNY ARSENAL NJ 07806-5000
1	DIRECTOR US ARMY RESEARCH LAB AMSRL OP SD TP 2800 POWDER MILL ROAD ADELPHI MD 20783-1145	1	COMMANDER US ARMY ARDEC AMSTA AR FSE T GORA PICATINNY ARSENAL NJ
2	DIRECTOR US ARMY RESEARCH LAB AMSRL OP CI AD TECH PUB BR RECORDS MGMT ADMIN 2800 POWDER MILL ROAD ADELPHI MD 20783-1197	6	COMMANDER US ARMY ARDEC AMSTA AR CCH A W ANDREWS S MUSALLI R CARR M LUCIANO E LOGSDEN T LOUZEIRO PICATINNY ARSENAL NJ 07806-5000
1	HQDA DAMI FIT NOLAN BLDG WASHINGTON DC 20310-1025	4	COMMANDER US ARMY ARDEC AMSTA AR CC G PAYNE J GEHBAUER C BAULIEU H OPAT PICATINNY ARSENAL NJ 07806-5000
1	DIRECTOR DA OASARDA SARD SO 103 ARMY PENTAGON WASHINGTON DC 20310-0103		
1	DEPUTY ASST SCY FOR R&T SARD TT RM 3EA79 THE PENTAGON WASHINGTON DC 20301-7100		

<u>NO. OF COPIES</u>	<u>ORGANIZATION</u>
1	COMMANDER US ARMY ARDEC AMSTA AR CCH P J LUTZ PICATINNY ARSENAL NJ 07806-5000
1	COMMANDER US ARMY ARDEC AMSTA AR FSF T C LIVECCHIA PICATINNY ARSENAL NJ 07806-5000
1	COMMANDER US ARMY ARDEC AMSTA AR QAC T C C PATEL PICATINNY ARSENAL NJ 07806-5000
2	COMMANDER US ARMY ARDEC AMSTA AR M D DEMELLA F DIORIO PICATINNY ARSENAL NJ 07806-5000
3	COMMANDER US ARMY ARDEC AMSTA AR FSA A WARNASH B MACHAK M CHIEFA PICATINNY ARSENAL NJ 07806-5000
2	COMMANDER US ARMY ARDEC AMSTA AR FSP G M SCHIKSNIS D CARLUCCI PICATINNY ARSENAL NJ 07806-5000

<u>NO. OF COPIES</u>	<u>ORGANIZATION</u>
1	COMMANDER US ARMY ARDEC AMSTA AR FSP A P KISATSKY PICATINNY ARSENAL NJ 07806-5000
2	COMMANDER US ARMY ARDEC AMSTA AR CCH C H CHANIN S CHICO PICATINNY ARSENAL NJ 07806-5000
9	COMMANDER US ARMY ARDEC AMSTA AR CCH B P DONADIA F DONLON P VALENTI C KNUTSON G EUSTICE S PATEL G WAGNECZ R SAYER F CHANG PICATINNY ARSENAL NJ 07806-5000
6	COMMANDER US ARMY ARDEC AMSTA AR CCL F PUZYCKI R MCHUGH D CONWAY E JAROSZEWSKI R SCHLENNER M CLUNE PICATINNY ARSENAL NJ 07806-5000
1	COMMANDER US ARMY ARDEC AMSTA AR QAC T D RIGOGLIOSO PICATINNY ARSENAL NJ 07806-5000

<u>NO. OF COPIES</u>	<u>ORGANIZATION</u>	<u>NO. OF COPIES</u>	<u>ORGANIZATION</u>
1	COMMANDER US ARMY ARDEC AMSTA AR SRE D YEE PICATINNY ARSENAL NJ 07806-5000	2	PEO FIELD ARTILLERY SYSTEMS SFAE FAS PM H GOLDMAN T MCWILLIAMS PICATINNY ARSENAL NJ 07806-5000
1	COMMANDER US ARMY ARDEC AMSTA AR WET T SACHAR BLDG 172 PICATINNY ARSENAL NJ 07806-5000	6	PM SADARM SFAE GCSS SD COL B ELLIS M DEVINE R KOWALSKI W DEMASSI J PRITCHARD S HROWNAK PICATINNY ARSENAL NJ 07806-5000
1	COMMANDER US ARMY ARDEC SMCAR ASF PICATINNY ARSENAL NJ 07806-5000	1	COMMANDER US ARMY ARDEC PRODUCTION BASE MODERN ACTY AMSMC PBM K PICATINNY ARSENAL NJ 07806-5000
1	COMMANDER US ARMY ARDEC AMSTA AR WEL F INTELLIGENCE SPECIALIST M GUERRIERE PICATINNY ARSENAL NJ 07806-5000	3	COMMANDER U S ARMY TACOM PM TACTICAL VEHICLES SFAE TVL SFAE TVM SFAE TVH 6501 ELEVEN MILE RD WARREN MI 48397-5000
11	PROJECT MANAGER TANK MAIN ARMAMENT SYSTEMS SFAE GSSC TMA R MORRIS C KIMKER D GUZOWICZ E KOPACZ R ROESER R DARCY R MCDANOLDS L D ULISSE C ROLLER J MCGREEN B PATTEN PICATINNY ARSENAL NJ 07806-5000	1	COMMANDER U S ARMY TACOM PM ABRAMS SFAE ASM AB 6501 ELEVEN MILE RD WARREN MI 48397-5000
		1	COMMANDER U S ARMY TACOM PM BFVS SFAE ASM BV 6501 ELEVEN MILE RD WARREN MI 48397-5000

<u>NO. OF</u> <u>COPIES</u>	<u>ORGANIZATION</u>	<u>NO. OF</u> <u>COPIES</u>	<u>ORGANIZATION</u>
1	COMMANDER U S ARMY TACOM PM AFAS SFAE ASM AF 6501 ELEVEN MILE RD WARREN MI 48397-5000	1	COMMANDER U S ARMY TACOM PM GROUND SYSTEMS INTEGRATION SFAE GCSS W GSI R LABATILLE 6501 ELEVEN MILE RD WARREN MI 48397-5000
2	COMMANDER U S ARMY TACOM PM SURV SYS SFAE ASM SS T DEAN SFAE GCSS W GSI M D COCHRAN 6501 ELEVEN MILE RD WARREN MI 48397-5000	1	COMMANDER U S ARMY TACOM CHIEF ABRAMS TESTING SFAE GCSS W AB QT T KRASKIEWICZ 6501 ELEVEN MILE RD WARREN MI 48397-5000
1	COMMANDER U S ARMY TACOM PM RDT&E SFAE GCSS W AB J GODELL 6501 ELEVEN MILE RD WARREN MI 48397-5000	1	COMMANDER US ARMY TACOM AMSTA SF WARREN MI 48397-5000
1	COMMANDER U S ARMY TACOM PM SURVIVABLE SYSTEMS SFAE GCSS W GSI H M RYZYI 6501 ELEVEN MILE RD WARREN MI 48397-5000	1	COMMANDER SMCWV QAE Q B VANINA BLDG 44 WATERVLIET ARSENAL WATERVLIET NY 12189-4050
1	COMMANDER U S ARMY TACOM PM BFV SFAE GCSS W BV S DAVIS 6501 ELEVEN MILE RD WARREN MI 48397-5000	14	COMMANDER US ARMY TACOM ASMTA TR R J CHAPIN R MCCLELLAND D THOMAS J BENNETT D HANSEN AMSTA JSK S GOODMAN J FLORENCE K IYER J THOMSON AMSTA TR D D OSTBERG L HINOJOSA B RAJU AMSTA CS SF H HUTCHINSON F SCHWARZ WARREN MI 48397-5000
1	COMMANDER U S ARMY TACOM PM LIGHT TACTICAL VEHICLES AMSTA TR S AJ J MILLS MS 209 6501 ELEVEN MILE RD WARREN MI 48397-5000		

<u>NO. OF COPIES</u>	<u>ORGANIZATION</u>
1	COMMANDER SMCWV SPM T MCCLOSKEY BLDG 253 WATERVLIET ARSENAL WATERVLIET NY 12189-4050
10	BENET LABORATORIES AMSTA AR CCB R FISCELLA G D ANDREA M SCAVULO G SPENCER P WHEELER K MINER J VASILAKIS G FRIAR R HASENBEIN SMCAR CCB R S SOPOK WATERVLIET NY 12189
2	TSM ABRAMS ATZK TS S JABURG W MEINSHAUSEN FT KNOX KY 40121
3	ARMOR SCHOOL ATTN ATZK TD R BAUEN J BERG A POMEY FT KNOX KY 40121
2	HQ IOC TANK AMMO TEAM AMSIO SMT R CRAWFORD W HARRIS ROCK ISLAND IL 61299-6000
1	DIRECTOR U S ARMY AMCOM SFAE AV RAM TV D CALDWELL BUILDING 5300 REDSTONE ARSENAL AL 35898

<u>NO. OF COPIES</u>	<u>ORGANIZATION</u>
4	DIRECTOR US ARMY CECOM NIGHT VISION AND ELECTRONIC SENSORS DIRECTORATE AMSEL RD NV CM CCD R ADAMS R MCLEAN A YINGST AMSEL RD NV VISP E JACOBS 10221 BURBECK RD FT BELVOIR VA 22060-5806
2	CDR USA AMCOM AVIATION APPLIED TECH DIR J SCHUCK FT EUSTIS VA 23604-5577
1	U S ARMY CRREL P DUTTA 72 LYME RD HANOVER NH 03755
1	US ARMY CERL R LAMPO 2902 NEWMARK DR CHAMPAIGN IL 61822
2	U S ARMY CORP OF ENGINEERS CERD C T LIU CEW ET T TAN 20 MASS AVE NW WASHINGTON DC 20314
10	DIRECTOR US ARMY NATL GRND INTEL CTR D LEITER S EITELMAN M HOLTUS M WOLFE S MINGLEDORF H C ARDLEIGH J GASTON W GSTATTENBAUER R WARNER J CRIDER 220 SEVENTH STREET NE CHARLOTTESVILLE VA 22091

<u>NO. OF</u> <u>COPIES</u>	<u>ORGANIZATION</u>	<u>NO. OF</u> <u>COPIES</u>	<u>ORGANIZATION</u>
6	US ARMY SBCCOM SOLDIER SYSTEMS CENTER BALLISTICS TEAM J WARD MARINE CORPS TEAM J MACKIEWICZ BUS AREA ADVOCACY TEAM W HASKELL SSCNC WST W NYKVIST T MERRILL S BEAUDOIN KANSAS ST NATICK MA 01760-5019	1	COMMANDANT U S ARMY FIELD ARTILLERY CTR AT FT SILL ATFS CD LTC BUMGARNER FT SILL OK 73503 5600
1	US ARMY COLD REGIONS RSCH & ENGRNG LAB P DUTTA 72 LYME RD HANOVER NH 03755	1	CHIEF USAIC LTC T J CUMMINGS ATZB COM FT BENNING GA 31905-5800
1	SYSTEM MANAGER ABRAMS BLDG 1002 RM 110 ATZK TS LTC J H NUNN FT KNOX KY 40121	1	NAVAL AIR SYSTEMS CMD J THOMPSON 48142 SHAW RD UNIT 5 PATUXENT RIVER MD 20670
9	US ARMY RESEARCH OFFICE A CROWSON J CHANDRA H EVERETT J PRATER R SINGLETON G ANDERSON D STEPP D KISEROW J CHANG PO BOX 12211 RESEARCH TRIANGLE PARK NC 27709-2211	1	NAVAL SURFACE WARFARE CTR DAHLGREN DIV CODE G06 DAHLGREN VA 22448
1	DIRECTORATE OF CMBT DEVELOPMENT C KJORO 320 ENGINEER LOOP STE 141 FT LEONARD WOOD MO 65473-8929	1	NAVAL SURFACE WARFARE CTR TECH LIBRARY CODE 323 17320 DAHLGREN RD DAHLGREN VA 22448
		3	NAVAL RESEARCH LAB I WOLOCK CODE 6383 R BADALIANCE CODE 6304 L GAUSE WASHINGTON DC 20375
		1	NAVAL SURFACE WARFARE CTR CRANE DIVISION M JOHNSON CODE 20H4 LOUISVILLE KY 40214-5245
		2	COMMANDER NAVAL SURFACE WARFARE CTR CADEROCK DIVISION R PETERSON CODE 2020 M CRITCHFIELD CODE 1730 BETHESDA MD 20084
		2	NAVAL SURFACE WARFARE CTR U SORATHIA C WILLIAMS CD 6551 9500 MACARTHUR BLVD WEST BETHESDA MD 20817

<u>NO. OF COPIES</u>	<u>ORGANIZATION</u>	<u>NO. OF COPIES</u>	<u>ORGANIZATION</u>
1	DAVID TAYLOR RESEARCH CTR SHIP STRUCTURES & PROTECTION DEPARTMENT CODE 1702 J CORRADO BETHESDA MD 20084	1	NAVSEA OJRI PEO DD21 PMS500 G CAMPONESCHI 2351 JEFFERSON DAVIS HWY ARLINGTON VA 22242-5165
2	DAVID TAYLOR RESEARCH CTR R ROCKWELL W PHYLLAIER BETHESDA MD 20054-5000	1	EXPEDITIONARY WARFARE DIV N85 F SHOUP 2000 NAVY PENTAGON WASHINGTON DC 20350-2000
1	OFFICE OF NAVAL RESEARCH D SIEGEL CODE 351 800 N QUINCY ST ARLINGTON VA 22217-5660	1	AFRL MLBC 2941 P STREET RM 136 WRIGHT PATTERSON AFB OH 45433-7750
8	NAVAL SURFACE WARFARE CTR J FRANCIS CODE G30 D WILSON CODE G32 R D COOPER CODE G32 J FRAYSSE CODE G33 E ROWE CODE G33 T DURAN CODE G33 L DE SIMONE CODE G33 R HUBBARD CODE G33 DAHLGREN VA 22448	1	AFRL MLSS R THOMSON 2179 12TH STREET RM 122 WRIGHT PATTERSON AFB OH 45433-7718
1	NAVAL SEA SYSTEMS CMD D LIESE 2531 JEFFERSON DAVIS HIGHWAY ARLINGTON VA 22242-5160	2	AFRL F ABRAMS J BROWN BLDG 653 2977 P STREET STE 6 WRIGHT PATTERSON AFB OH 45433-7739
1	NAVAL SURFACE WARFARE M LACY CODE B02 17320 DAHLGREN RD DAHLGREN VA 22448	1	AFRL MLS OL 7278 4TH STREET BLDG 100 BAY D L COULTER HILL AFB UT 84056-5205
1	OFFICE OF NAVAL RES J KELLY 800 NORTH QUINCEY ST ARLINGTON VA 22217-5000	1	OSD JOINT CCD TEST FORCE OSD JCCD R WILLIAMS 3909 HALLS FERRY RD VICKSBURG MS 29180-6199
2	NAVAL SURFACE WARFARE CTR CARDEROCK DIVISION R CRANE CODE 2802 C WILLIAMS CODE 6553 3A LEGGETT CIR BETHESDA MD 20054-5000	1	DEFENSE NUCLEAR AGENCY INNOVATIVE CONCEPTS DIV R ROHR 6801 TELEGRAPH RD ALEXANDRIA VA 22310-3398

<u>NO. OF</u> <u>COPIES</u>	<u>ORGANIZATION</u>
1	WATERWAYS EXPERIMENT D SCOTT 3909 HALLS FERRY RD SC C VICKSBURG MS 39180
3	DARPA M VANFOSSEN S WAX L CHRISTODOULOU 3701 N FAIRFAX DR ARLINGTON VA 22203-1714
2	SERDP PROGRAM OFC PM P2 C PELLERIN B SMITH 901 N STUART ST SUITE 303 ARLINGTON VA 22203
1	FAA MIL HDBK 17 CHAIR L ILCEWICZ 1601 LIND AVE SW ANM 115N RENTON VA 98055
2	FAA TECH CENTER D OPLINGER AAR 431 P SHYPRYKEVICH AAR 431 ATLANTIC CITY NJ 08405
1	OFC OF ENVIRONMENTAL MGMT U S DEPT OF ENERGY P RITZCOVAN 19901 GERMANTOWN RD GERMANTOWN MD 20874-1928
1	LOS ALAMOS NATL LAB F ADDESSIO MS B216 PO BOX 1633 LOS ALAMOS NM 87545
1	OAK RIDGE NATL LAB R M DAVIS PO BOX 2008 OAK RIDGE TN 37831-6195

<u>NO. OF</u> <u>COPIES</u>	<u>ORGANIZATION</u>
5	DIRECTOR LAWRENCE LIVERMORE NATL LAB R CHRISTENSEN S DETERESA F MAGNESS M FINGER MS 313 M MURPHY L 282 PO BOX 808 LIVERMORE CA 94550
7	NIST R PARNAS J DUNKERS M VANLANDINGHAM MS 8621 J CHIN MS 8621 D HUNSTON MS 8543 J MARTIN MS 8621 D DUTHINH MS 8611 100 BUREAU DR GAITHERSBURG MD 20899
1	OAK RIDGE NATL LAB C EBERLE MS 8048 PO BOX 2009 OAK RIDGE TN 37831
1	OAK RIDGE NATL LAB C D WARREN MS 8039 PO BOX 2009 OAK RIDGE TN 37922
4	DIRECTOR SANDIA NATL LABS APPLIED MECHANICS DEPT DIVISION 8241 W KAWAHARA K PERANO D DAWSON P NIELAN PO BOX 969 LIVERMORE CA 94550-0096
1	LAWRENCE LIVERMORE NATIONAL LAB M MURPHY PO BOX 808 L 282 LIVERMORE CA 94550

<u>NO. OF COPIES</u>	<u>ORGANIZATION</u>
3	NASA LANGLEY RESEARCH CTR MS 266 AMSRL VS W ELBER F BARTLETT JR G FARLEY HAMPTON VA 23681-0001
1	NASA LANGLEY RESEARCH CTR T GATES MS 188E HAMPTON VA 23661-3400
1	USDOT FEDERAL RAILROAD RDV 31 M FATEH WASHINGTON DC 20590
1	DOT FHWA J SCALZI 400 SEVENTH ST SW 3203 HNG 32 WASHINGTON DC 20590
1	FHWA E MUNLEY 6300 GEORGETOWN PIKE MCLEAN VA 22101
1	CENTRAL INTELLIGENCE AGENCY OTI WDAG GT W L WALTMAN PO BOX 1925 WASHINGTON DC 20505
1	MARINE CORPS INTEL ACTY D KOSITZKE 3300 RUSSELL RD SUITE 250 QUANTICO VA 22134-5011
1	NATL GRND INTELLIGENCE CTR DIRECTOR IANG TMT 220 SEVENTH ST NE CHARLOTTESVILLE VA 22902-5396
1	DIRECTOR DEFENSE INTELLIGENCE AGENCY TA 5 K CRELLING WASHINGTON DC 20310

<u>NO. OF COPIES</u>	<u>ORGANIZATION</u>
1	GRAPHITE MASTERS INC J WILLIS 3815 MEDFORD ST LOS ANGELES CA 90063-1900
1	ADVANCED GLASS FIBER YARNS T COLLINS 281 SPRING RUN LN STE A DOWNINGTON PA 19335
1	COMPOSITE MATERIALS INC D SHORTT 19105 63 AVE NE PO BOX 25 ARLINGTON WA 98223
1	COMPOSITE MATERIALS INC R HOLLAND 11 JEWEL COURT ORINDA CA 94563
1	COMPOSITE MATERIALS INC C RILEY 14530 S ANSON AVE SANTA FE SPRINGS CA 90670
2	COMPOSIX D BLAKE L DIXON 120 O NEILL DR HEBRUN OHIO 43025
4	CYTEC FIBERITE R DUNNE D KOHLI M GILLIO R MAYHEW 1300 REVOLUTION ST HAVRE DE GRACE MD 21078
2	SIMULA J COLTMAN R HUYETT 10016 S 51ST ST PHOENIX AZ 85044
1	SIOUX MFG B KRIEL PO BOX 400 FT TOTTEN ND 58335

<u>NO. OF COPIES</u>	<u>ORGANIZATION</u>
2	PROTECTION MATERIALS INC M MILLER F CRILLEY 14000 NW 58 CT MIAMI LAKES FL 33014
3	FOSTER MILLER J J GASSNER M ROYLANCE W ZUKAS 195 BEAR HILL RD WALTHAM MA 02354-1196
1	ROM DEVELOPMENT CORP R O MEARA 136 SWINEBURNE ROW BRICK MARKET PLACE NEWPORT RI 02840
2	TEXTRON SYSTEMS T FOLTZ M TREASURE 201 LOWELL ST WILMINGTON MA 08870-2941
1	JPS GLASS L CARTER PO BOX 260 SLATER RD SLATER SC 29683
1	O GARA HESS & EISENHARDT M GILLESPIE 9113 LESAINTE DR FAIRFIELD OH 45014
2	MILLIKEN RESEARCH CORP H KUHN M MACLEOD PO BOX 1926 SPARTANBURG SC 29303
1	CONNEAUGHT INDUSTRIES INC J SANTOS PO BOX 1425 COVENTRY RI 02816

<u>NO. OF COPIES</u>	<u>ORGANIZATION</u>
1	BATTELLE C R HARGREAVES 505 KING AVE COLUMBUS OH 43201-2681
2	BATTELLE NATICK OPERATIONS J CONNORS B HALPIN 209 W CENTRAL ST STE 302 NATICK MA 01760
1	BATTELLE NW DOE PNNL T HALL MS K231 BATTELLE BLVD RICHLAND WA 99352
3	PACIFIC NORTHWEST LAB M SMITH G VAN ARSDALE R SHIPPELL PO BOX 999 RICHLAND WA 99352
1	ARMTEC DEFENSE PRODUCTS S DYER 85 901 AVE 53 PO BOX 848 COACHELLA CA 92236
2	ADVANCED COMPOSITE MATLS CORP P HOOD J RHODES 1525 S BUNCOMBE RD GREER SC 29651-9208
2	GLCC INC J RAY M BRADLEY 103 TRADE ZONE DR STE 26C WEST COLUMBIA SC 29170
2	AMOCO PERFORMANCE PRODUCTS M MICHNO JR J BANISAUKAS 4500 MCGINNIS FERRY RD ALPHARETTA GA 30202-3944

<u>NO. OF COPIES</u>	<u>ORGANIZATION</u>
1	SAIC M PALMER 2109 AIR PARK RD S E ALBUQUERQUE NM 87106
1	SAIC ATTN G CHRYSSOMALLIS 3800 W 80TH ST STE 1090 BLOOMINGTON MN 55431
1	AAI CORPORATION DR T G STASTNY PO BOX 126 HUNT VALLEY MD 21030-0126
1	JOHN HEBERT PO BOX 1072 HUNT VALLEY MD 21030-0126
12	ALLIANT TECHSYSTEMS INC C CANDLAND C AAKHUS R BECKER B SEE N VLAHAKUS R DOHRN S HAGLUND D FISHER W WORRELL R COPENHAFFER M HISSONG D KAMDAR 600 2ND ST NE HOPKINS MN 55343-8367
3	ALLIANT TECHSYSTEMS INC J CONDON E LYNAM J GERHARD WV01 16 STATE RT 956 PO BOX 210 ROCKET CENTER WV 26726-0210
1	APPLIED COMPOSITES W GRISCH 333 NORTH SIXTH ST ST CHARLES IL 60174

<u>NO. OF COPIES</u>	<u>ORGANIZATION</u>
1	PROJECTILE TECHNOLOGY INC 515 GILES ST HAVRE DE GRACE MD 21078
1	CUSTOM ANALYTICAL ENG SYS INC A ALEXANDER 13000 TENSOR LN NE FLINTSTONE MD 21530
2	LORAL VOUGHT SYSTEMS G JACKSON K COOK 1701 W MARSHALL DR GRAND PRAIRIE TX 75051
5	AEROJET GEN CORP D PILLASCH T COULTER C FLYNN D RUBAREZUL M GREINER 1100 WEST HOLLYVALE ST AZUSA CA 91702-0296
3	HEXCEL INC R BOE F POLICELLI J POESCH PO BOX 98 MAGNA UT 84044
3	HERCULES INC G KUEBELER J VERMEYCHUK B MANDERVILLE JR HERCULES PLAZA WILMINGTON DE 19894
1	BRIGS COMPANY J BACKOFEN 2668 PETERBOROUGH ST HERDON VA 22071-2443
1	ZERNOW TECHNICAL SERVICES L ZERNOW 425 W BONITA AVE STE 208 SAN DIMAS CA 91773

<u>NO. OF</u> <u>COPIES</u>	<u>ORGANIZATION</u>	<u>NO. OF</u> <u>COPIES</u>	<u>ORGANIZATION</u>
2	OLIN CORPORATION FLINCHBAUGH DIV E STEINER B STEWART PO BOX 127 RED LION PA 17356	1	BOEING R BOHLMANN PO BOX 516 MC 5021322 ST LOUIS MO 63166-0516
1	OLIN CORPORATION L WHITMORE 10101 9TH ST NORTH ST PETERSBURG FL 33702	2	BOEING DEFENSE AND SPACE GRP W HAMMOND J RUSSELL S 4X55 PO BOX 3707 SEATTLE WA 98124-2207
1	DOW UT S TIDRICK 15 STERLING DR WALLINGFORD CT 06492	2	BOEING ROTORCRAFT P MINGURT P HANDEL 800 B PUTNAM BLVD WALLINGFORD PA 19086
5	SIKORSKY AIRCRAFT G JACARUSO T CARSTENSAN B KAY S GARBO M S S330A J ADELMANN 6900 MAIN ST PO BOX 9729 STRATFORD CT 06497-9729	1	BOEING DOUGLAS PRODUCTS DIV L J HART SMITH 3855 LAKEWOOD BLVD D800 0019 LONG BEACH CA 90846-0001
1	PRATT & WHITNEY D HAMBRICK 400 MAIN ST MS 114 37 EAST HARTFORD CT 06108	1	LOCKHEED MARTIN S REEVE 8650 COBB DR D 73 62 MZ 0648 MARIETTA GA 30063-0648
1	AEROSPACE CORP G HAWKINS M4 945 2350 E EL SEGUNDO BLVD EL SEGUNDO CA 90245	1	LOCKHEED MARTIN SKUNK WORKS D FORTNEY 1011 LOCKHEED WAY PALMDALE CA 93599-2502
2	CYTEC FIBERITE M LIN W WEB 1440 N KRAEMER BLVD ANAHEIM CA 92806	1	LOCKHEED MARTIN R FIELDS 1195 IRWIN CT WINTER SPRINGS FL 32708
1	HEXCEL T BITZER 11711 DUBLIN BLVD DUBLIN CA 94568	1	MATERIALS SCIENCES CORP B W ROSEN 500 OFFICE CENTER DR STE 250 FORT WASHINGTON PA 19034

<u>NO. OF COPIES</u>	<u>ORGANIZATION</u>
1	NORTHROP GRUMMAN CORP ELECTRONIC SENSORS & SYSTEMS DIV E SCHOCH 1745A WEST NURSERY RD MAILSTOP V 16 LINTHICUM MD 21090
2	NORTHROP GRUMMAN ENVIRONMENTAL PROGRAMS R OSTERMAN A YEN 8900 E WASHINGTON BLVD PICO RIVERA CA 90660
1	UNITED DEFENSE LP PO BOX 359 D MARTIN SANTA CLARA CA 95052
1	UNITED DEFENSE LP PO BOX 58123 G THOMAS SANTA CLARA CA 95052
2	UNITED DEFENSE LP MAIL DROP M53 R BARRETT V HORVATICH 328 W BROKAW RD SANTA CLARA CA 95052-0359
3	UNITED DEFENSE LP GROUND SYSTEMS DIVISION M PEDRAZZI MAIL DROP N09 A LEE MAIL DROP N11 M MACLEAN MAIL DROP N06 1205 COLEMAN AVE SANTA CLARA CA 95052
4	UNITED DEFENSE LP 4800 EAST RIVER RD R BRYNSVOLD P JANKE MS170 T GIOVANETTI MS236 B VAN WYK MS389 MINNEAPOLIS MN 55421-1498

<u>NO. OF COPIES</u>	<u>ORGANIZATION</u>
2	GENERAL DYNAMICS LAND SYSTEMS D REES M PASIK PO BOX 2074 WARREN MI 48090-2074
1	GENERAL DYNAMICS LAND SYSTEMS DIVISION D BARTLE PO BOX 1901 WARREN MI 48090
1	GENERAL DYNAMICS LAND SYSTEMS MUSKEGON OPERATIONS W SOMMERS JR 76 GETTY ST MUSKEGON MI 49442
1	GENERAL DYNAMICS AMPHIBIOUS SYS SURVIVABILITY LEAD G WALKER 991 ANNAPOLIS WAY WOODBIDGE VA 22191
5	INSTITUTE FOR ADVANCED TECH T KIEHNE H FAIR P SULLIVAN W REINECKE I MCNAB 4030 2 W BRAKER LN AUSTIN TX 78759
2	CIVIL ENGR RSCH FOUNDATION H BERNSTEIN PRESIDENT R BELLE 1015 15TH ST NW STE 600 WASHINGTON DC 20005
1	ARROW TECH ASSO 1233 SHELBURNE RD STE D 8 SOUTH BURLINGTON VT 05403-7700

<u>NO. OF</u> <u>COPIES</u>	<u>ORGANIZATION</u>	<u>NO. OF</u> <u>COPIES</u>	<u>ORGANIZATION</u>
1	CONSULTANT R EICHELBERGER 409 W CATHERINE ST BEL AIR MD 21014-3613	1	UNIVERSITY OF UTAH DEPT OF MECH & INDUSTRIAL ENGR S SWANSON SALT LAKE CITY UT 84112
1	UCLA MANE DEPT ENGR IV H THOMAS HAHN LOS ANGELES CA 90024-1597	2	PENNSYLVANIA STATE UNIV R MCNITT C BAKIS 227 HAMMOND BLDG UNIVERSITY PARK PA 16802
2	U OF DAYTON RESEARCH INSTUTE RAN Y KIM AJIT K ROY 300 COLLEGE PARK AVE DAYTON OH 45469-0168	1	PENNSYLVANIA STATE UNIV RENATA S ENGEL 245 HAMMOND BLDG UNIVERSITY PARK PA 16801
1	MIT P LAGACE 77 MASS AVE CAMBRIDGE MA 01887	1	PURDUE UNIVERSITY SCHOOL OF AERO & ASTRO C T SUN W LAFAYETTE IN 47907-1282
1	IIT RESEARCH CENTER D ROSE 201 MILL ST ROME NY 13440-6916	1	STANFORD UNIVERSITY DEPARTMENT OF AERONAUTICS AND AEROBALLISTICS DURANT BUILDING S TSAI STANFORD CA 94305
1	GEORGIA TECH RESEARCH INSTITUTE GEORGIA INSTITUTE OF TECHNOLOGY P FRIEDERICH ATLANTA GA 30392	1	UNIVERSITY OF DAYTON J M WHITNEY COLLEGE PARK AVE DAYTON OH 45469-0240
1	MICHIGAN ST UNIVERSITY R AVERILL 3515 EB MSM DEPT EAST LANSING MI 48824-1226	7	UNIVERSITY OF DELAWARE CTR FOR COMPOSITE MATERIALS J GILLESPIE M SANTARE G PALMESE S YARLAGADDA S ADVANI D HEIDER D KUKICH 201 SPENCER LABORATORY NEWARK DE 19716
1	UNIVERSITY OF KENTUCKY LYNN PENN 763 ANDERSON HALL LEXINGTON KY 40506-0046		
1	UNIVERSITY OF WYOMING D ADAMS PO BOX 3295 LARAMIE WY 82071		

<u>NO. OF COPIES</u>	<u>ORGANIZATION</u>	<u>NO. OF COPIES</u>	<u>ORGANIZATION</u>
1	UNIVERSITY OF ILLINOIS AT URBANA CHAMPAIGN NATL CENTER FOR COMPOSITE MATERIALS RESEARCH 216 TALBOT LABORATORY J ECONOMY 104 S WRIGHT ST URBANA IL 61801		<u>ABERDEEN PROVING GROUND</u>
		1	COMMANDER US ARMY MATERIEL SYS ANALYSIS P DIETZ 392 HOPKINS RD AMXSU TD APG MD 21005-5071
3	THE UNIVERSITY OF TEXAS AT AUSTIN CENTER FOR ELECTROMECHANICS J PRICE A WALLS J KITZMILLER 10100 BURNET RD AUSTIN TX 78758-4497	1	DIRECTOR US ARMY RESEARCH LAB AMSRL OP AP L APG MD 21005 5066
		115	DIR USARL AMSRL CI AMSRL CI H W STUREK AMSRL CI S A MARK AMSRL CS IO FI M ADAMSON AMSRL SL B J SMITH AMSRL SL BA AMSRL SL BL D BELY R HENRY AMSRL SL BG A YOUNG AMSRL SL I AMSRL WM B A HORST E SCHMIDT AMSRL WM BA W D AMICO F BRANDON AMSRL WM BC P PLOSTINS D LYON J NEWILL S WILKERSON A ZIELINSKI AMSRL WM BD B FORCH R FIFER R PESCE RODRIGUEZ B RICE
3	VA POLYTECHNICAL INSTITUTE & STATE UNIVERSITY DEPT OF ESM M W HYER K REIFSNIDER R JONES BLACKSBURG VA 24061-0219		
1	NORTH CAROLINA STATE UNIVERSITY CIVIL ENGINEERING DEPT W RASDORF PO BOX 7908 RALEIGH NC 27696-7908		
1	UNIVERSITY OF MARYLAND DEPT OF AEROSPACE ENGINEERING ANTHONY J VIZZINI COLLEGE PARK MD 20742		
1	DREXEL UNIVERSITY ALBERT S D WANG 32ND AND CHESTNUT STREETS PHILADELPHIA PA 19104		
1	SOUTHWEST RSCH INSTITUTE ENGR & MATL SCIENCES DIV J RIEGEL 6220 CULEBRA RD PO DRAWER 28510 SAN ANTONIO TX 78228-0510		

NO. OF  
COPIES    ORGANIZATION

ABERDEEN PROVING GROUND (CONT)

AMSRL WM BE  
G WREN  
C LEVERITT  
D KOOKER  
AMSRL WM BR  
C SHOEMAKER  
J BORNSTEIN  
AMSRL WM M  
D VIECHNICKI  
G HAGNAUER  
J MCCAULEY  
B TANNER  
AMSRL WM MA  
R SHUFORD  
P TOUCHET  
N BECK TAN  
D FLANAGAN  
L GHIORSE  
D HARRIS  
S MCKNIGHT  
P MOY  
S NGYUEN  
P PATTERSON  
G RODRIGUEZ  
A TEETS  
R YIN  
AMSRL WM MB  
B FINK  
J BENDER  
T BLANAS  
T BOGETTI  
R BOSSOLI  
L BURTON  
K BOYD  
S CORNELISON  
P DEHMER  
R DOOLEY  
W DRYSDALE  
G GAZONAS  
S GHIORSE  
D GRANVILLE  
D HOPKINS  
C HOPPEL  
D HENRY  
R KASTE  
M KLUSEWITZ  
M LEADORE  
R LIEB

NO. OF  
COPIES    ORGANIZATION

ABERDEEN PROVING GROUND (CONT)

AMSRL WM MB  
E RIGAS  
J SANDS  
D SPAGNUOLO  
W SPURGEON  
J TZENG  
E WETZEL  
A ABRAHAMIAN  
M BERMAN  
A FRYDMAN  
T LI  
W MCINTOSH  
E SZYMANSKI  
AMSRL WM MC  
J BEATTY  
J SWAB  
E CHIN  
J MONTGOMERY  
A WERESCZCAK  
J LASALVIA  
J WELLS  
AMSRL WM MD  
W ROY  
S WALSH  
AMSRL WM T  
B BURNS  
AMSRL WM TA  
W GILLICH  
T HAVEL  
J RUNYEON  
M BURKINS  
E HORWATH  
B GOOCH  
W BRUCHEY  
AMSRL WM TC  
R COATES  
AMSRL WM TD  
A DAS GUPTA  
T HADUCH  
T MOYNIHAN  
F GREGORY  
A RAJENDRAN  
M RAFTENBERG  
M BOTELER  
T WEERASOORIYA  
D DANDEKAR  
A DIETRICH

NO. OF  
COPIES    ORGANIZATION

ABERDEEN PROVING GROUND (CONT)

AMSRL WM TE  
  A NILER  
  J POWELL  
AMSRL SS SD  
  H WALLACE  
AMSRL SS SE R  
  R CHASE  
AMSRL SS SE DS  
  R REYZER  
  R ATKINSON  
AMSRL SE L  
  R WEINRAUB  
  J DESMOND  
  D WOODBURY

NO. OF  
COPIES    ORGANIZATION

NO. OF  
COPIES    ORGANIZATION

1    R MARTIN  
      MERL  
      LTD  
      TAMWORTH RD  
      HERTFORD SG13 7DG  
      UK

2    ROYAL MILITARY COLLEGE OF  
      SCIENCE SHRIVENHAM  
      D BULMAN  
      B LAWTON  
      SWINDON WILTS SN6 8LA  
      UNITED KINGDOM

1    PW LAY  
      SMC SCOTLAND  
      DERA ROSYTH  
      ROSYTH ROYAL DOCKYARD  
      DUNFERMLINE FIFE KY 11 2XR  
      UK

1    SWISS FEDERAL ARMAMENTS  
      WKS  
      WALTER LANZ  
      ALLMENDSTRASSE 86  
      3602 THUN  
      SWITZERLAND

1    T GOTTESMAN  
      CIVIL AVIATION ADMINSTRATION  
      PO BOX 8  
      BEN GURION INTERNL AIRPORT  
      LOD 70150 ISRAEL

1    PROFESSOR SOL BODNER  
      ISRAEL INSTITUTE OF  
      TECHNOLOGY  
      FACULTY OF MECHANICAL ENGR  
      HAIFA 3200 ISRAEL

1    S ANDRE  
      AEROSPATIALE  
      A BTE CC RTE MD132  
      316 ROUTE DE BAYONNE  
      TOULOUSE 31060  
      FRANCE

1    DSTO MATERIALS RSRCH LAB  
      DR NORBERT BURMAN NAVAL  
      PLATFORM VULNERABILITY SHIP  
      STRUCTURES & MATERIALS DIV  
      PO BOX 50  
      ASCOT VALE VICTORIA  
      AUSTRALIA 3032

1    J BAUER  
      DAIMLER BENZ AEROSPACE  
      D 81663 MUNCHEN  
      MUNICH  
      GERMANY

1    PROFESSOR EDWARD CELENS  
      ECOLE ROYAL MILITAIRE  
      AVE DE LA RENAISSANCE 30  
      1040 BRUXELLE  
      BELGIQUE

3    DRA FORT HALSTEAD  
      PETER N JONES  
      DAVID SCOTT  
      MIKE HINTON  
      SEVEN OAKS KENT TN 147BP  
      UNITED KINGDOM

1    DEF RES ESTABLISHMENT  
      VALCARTIER  
      ALAIN DUPUIS  
      2459 BOULEVARD PIE XI NORTH  
      VALCARTIER QUEBEC  
      CANADA  
      PO BOX 8800 COURCELETTE  
      GOA IRO QUEBEC CANADA

1    MR FRANCOIS LESAGE  
      DEFENSE RESEARCH ESTAB  
      VALCARTIER  
      PO BOX 8800  
      COURCELETTE QUEBEC COA  
      IRO CANADA

<u>NO. OF</u> <u>COPIES</u>	<u>ORGANIZATION</u>
1	INSTITUT FRANCO ALLEMAND DE RECHERCHES DE SAINT LOUIS DE MARC GIRAUD RUE DU GENERAL CASSAGNOU BOITE POSTALE 34 F 68301 SAINT LOUIS CEDEX FRANCE
1	J MANSON ECOLE POLYTECH DMX LTC CH 1015 LAUSANNE SWITZERLAND
1	TNO PRINS MAURITS LAB DR ROB IJSSELSTEIN LANGE KLEIWEG 137 PO BOX 45 2280 AA RIJSWIJK THE NETHERLANDS
2	FOA NAT L DEFENSE RESEARCH ESTAB DR BO JANZON R HOLMLIN DIR DEPT OF WEAPONS & PROTECTION S 172 90 STOCKHOLM SWEDEN
2	DEFENSE TECH & PROC AGENCY GRND MR I CREWTHIER GENERAL HERZOG HAUS 3602 THUN SWITZERLAND
1	MINISTRY OF DEFENCE RAFAEL DR MEIR MAYSELESS ARMAMENT DEVELOPMENT AUTH PO BOX 2250 HAIFA 31021 ISRAEL
1	DR AKE PERSSON DYNAMEC RESEARCH AB PARADISGRND 7 S 151 36 SODERTALJE SWEDEN

<u>NO. OF</u> <u>COPIES</u>	<u>ORGANIZATION</u>
1	ERNST MACH INSTITUT EMI DIRECTOR HAUPTSTRASSE 18 79576 WEIL AM RHEIN GERMANY
1	ERNST MACH INSTITUT EMI DR ALOIS STILP ECKERSTRASSE 4 7800 FREIBURG GERMANY
1	DR IR HANS PASMAN TNO DEFENSE RESEARCH POSTBUS 6006 2600 JA DELFT THE NETHERLANDS
1	DR BITAN HIRSCH TACHKEMONY ST 6 NETAMUA 42611 ISRAEL
1	PROF DR MANFRED HELD DEUTSCHE AEROSPACE AG DYNAMICS SYSTEMS PO BOX 1340 D 86523 SCHROBENHAUSEN GERMANY

# REPORT DOCUMENTATION PAGE

*Form Approved*  
*OMB No. 0704-0188*

Public reporting burden for this collection of information is estimated to average 1 hour per response, including the time for reviewing instructions, searching existing data sources, gathering and maintaining the data needed, and completing and reviewing the collection of information. Send comments regarding this burden estimate or any other aspect of this collection of information, including suggestions for reducing this burden, to Washington Headquarters Services, Directorate for Information Operations and Reports, 1215 Jefferson Davis Highway, Suite 1204, Arlington, VA 22202-4302, and to the Office of Management and Budget, Paperwork Reduction Project(0704-0188), Washington, DC 20503.

1. AGENCY USE ONLY (Leave blank)	2. REPORT DATE <p style="text-align: center;">June 2000</p>	3. REPORT TYPE AND DATES COVERED <p style="text-align: center;">Final, Jan 96-Mar 98</p>	
4. TITLE AND SUBTITLE Ionic Doping of Low-Conductivity Structural Resins for Improved Direct-Current Sensing		5. FUNDING NUMBERS <p style="text-align: center;">AH42</p>	
6. AUTHOR(S)  Bruce K. Fink, Kenric M. England,* and John W. Gillespie, Jr.*		8. PERFORMING ORGANIZATION REPORT NUMBER  <p style="text-align: center;">ARL-TR-2239</p>	
7. PERFORMING ORGANIZATION NAME(S) AND ADDRESS(ES)  U.S. Army Research Laboratory ATTN: AMSRL-WM-MC Aberdeen Proving Ground, MD 21005-5069		10. SPONSORING/MONITORING AGENCY REPORT NUMBER	
9. SPONSORING/MONITORING AGENCY NAMES(S) AND ADDRESS(ES)		11. SUPPLEMENTARY NOTES  *University of Delaware, Newark, DE 19716	
12a. DISTRIBUTION/AVAILABILITY STATEMENT  Approved for public release; distribution is unlimited.		12b. DISTRIBUTION CODE	
13. ABSTRACT (Maximum 200 words)  This investigation developed a methodology for doping high-resistivity vinyl-ester (VE) resins with an organic dopant. The polymeric resin system investigated was a Dow Derakane 411-C50 VE resin. A number of potential dopants were studied, and two in particular, tetrabutylammonium acetate (TA) and tetrabutylammonium iodide, were found to be capable of increasing the ionic conductivity of VE resin without adversely affecting the resin viscosity, mechanical properties, or reaction kinetics. The primary candidate dopant that was characterized in this investigation was a TA organic salt. TA, at a 0.1-weight-percent (wt%) concentration, was shown to have negligible effects on the mechanical properties and reaction kinetics of a curing VE part. TA was also found to slightly increase the rate at which viscosity increases, but not to the extent that would hinder resin transfer molding of a doped VE system. This investigation has proven that doping of VE resin with 0.1-wt% TA is a viable means of controlling and tailoring the conductivity of high-resistivity resins for the application of direct-current (DC)-sensing technology.			
14. SUBJECT TERMS  SMARTweave, composites, resin transfer molding, ionic conductivity, doping		15. NUMBER OF PAGES <p style="text-align: center;">55</p>	16. PRICE CODE
17. SECURITY CLASSIFICATION OF REPORT <p style="text-align: center;">UNCLASSIFIED</p>	18. SECURITY CLASSIFICATION OF THIS PAGE <p style="text-align: center;">UNCLASSIFIED</p>	19. SECURITY CLASSIFICATION OF ABSTRACT <p style="text-align: center;">UNCLASSIFIED</p>	20. LIMITATION OF ABSTRACT <p style="text-align: center;">UL</p>

INTENTIONALLY LEFT BLANK.

USER EVALUATION SHEET/CHANGE OF ADDRESS

This Laboratory undertakes a continuing effort to improve the quality of the reports it publishes. Your comments/answers to the items/questions below will aid us in our efforts.

1. ARL Report Number/Author ARL-TR-2239 (Fink) Date of Report June 2000

2. Date Report Received \_\_\_\_\_

3. Does this report satisfy a need? (Comment on purpose, related project, or other area of interest for which the report will be used.) \_\_\_\_\_

4. Specifically, how is the report being used? (Information source, design data, procedure, source of ideas, etc.) \_\_\_\_\_

5. Has the information in this report led to any quantitative savings as far as man-hours or dollars saved, operating costs avoided, or efficiencies achieved, etc? If so, please elaborate. \_\_\_\_\_

6. General Comments. What do you think should be changed to improve future reports? (Indicate changes to organization, technical content, format, etc.) \_\_\_\_\_

CURRENT ADDRESS

Organization
Name E-mail Name
Street or P.O. Box No.
City, State, Zip Code

7. If indicating a Change of Address or Address Correction, please provide the Current or Correct address above and the Old or Incorrect address below.

OLD ADDRESS

Organization
Name
Street or P.O. Box No.
City, State, Zip Code

(Remove this sheet, fold as indicated, tape closed, and mail.)
(DO NOT STAPLE)

---

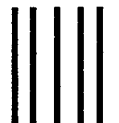
DEPARTMENT OF THE ARMY

OFFICIAL BUSINESS

**BUSINESS REPLY MAIL**  
FIRST CLASS PERMIT NO 0001, APG, MD

POSTAGE WILL BE PAID BY ADDRESSEE

DIRECTOR  
US ARMY RESEARCH LABORATORY  
ATTN AMSRL WM MB  
ABERDEEN PROVING GROUND MD 21005-5069



NO POSTAGE  
NECESSARY  
IF MAILED  
IN THE  
UNITED STATES

