

Spatial-phase-locked Electron-beam Lithography"
Project Period: August 1, 1995 – September 30, 1999
Final Report

Spatial-phase-locked electron-beam lithography (SPLEBL) is a novel approach to achieving very high pattern-placement accuracy, and precision, in electron-beam lithography. The accuracy achieved by SPLEBL is essential in order to enable the continuation of next-generation lithography techniques to below 20-nm feature sizes. The following tasks were completed during this research program:

1. Measurement survey of secondary-electron signals from candidate fiducial-grid materials.
2. Experimental demonstration of real-time SPLEBL in 1-D with an external, analog delay-locked loop (DLL): ~5 nm pattern-placement accuracy achieved.
3. Numerical simulation of 1-D SPLEBL using a DLL.
4. Development and calibration of a field-stitching measurement routine capable of detecting stitching errors below 5-nm.
5. Design of a 2-D DLL for real-time SPLEBL.
6. Study of fiducial-grid-induced electron scattering with a Monte-Carlo simulator.
7. Survey of high-speed dose-modulation schemes for real-time SPLEBL.
8. Development of a scintillating polymer suitable for use as a global-fiducial grid.
9. Initial assembly of a test column.
10. Development of a 2-D sparse-sampling algorithm for SPLEBL.

Overview of SPLEBL:

Spatial-phase-locked electron-beam lithography represents a new paradigm for electron-beam-lithography EBL tools. In conventional EBL tools, the true position of the electron beam in reference to the substrate is not know while patterns are being written on the substrate. Mark-detection routines and a laser-interferometer-controlled stage are used to deduce the position of the e-beam prior to writing, but with system instabilities and drift the true beam position can become

REPORT DOCUMENTATION PAGE			Form Approved OMB NO. 0704-0188	
Public reporting burden for this collection of information is estimated to average 1 hour per response, including the time for reviewing instructions, searching existing data sources, gathering and maintaining the data needed, and completing and reviewing the collection of information. Send comment regarding this burden estimate or any other aspect of this collection of information, including suggestions for reducing this burden, to Washington Headquarters Services, Directorate for Information Operations and Reports, 1215 Jefferson Davis Highway, Suite 1204, Arlington, VA 22202-4302, and to the Office of Management and Budget, Paperwork Reduction Project (0704-0188), Washington, DC 20503.				
1. AGENCY USE ONLY (Leave blank)		2. REPORT DATE 12/30/99	3. REPORT TYPE AND DATES COVERED Final Progress 8/1/95 - 9/30/99	
4. TITLE AND SUBTITLE Spatial-phase-locked Electron-beam Lithography			5. FUNDING NUMBERS DAAH04-95-1-0564	
6. AUTHOR(S) Prof. Henry I. Smith				
7. PERFORMING ORGANIZATION NAME(S) AND ADDRESS(ES) Research Laboratory of Electronics Massachusetts Institute of Technology 77 Massachusetts Avenue Cambridge, MA 02139-4307			8. PERFORMING ORGANIZATION REPORT NUMBER	
9. SPONSORING / MONITORING AGENCY NAME(S) AND ADDRESS(ES) U.S. Army Research Office P.O. Box 12211 Research Triangle Park, NC 27709-2211			10. SPONSORING / MONITORING AGENCY REPORT NUMBER ARO 34906.9-EL	
11. SUPPLEMENTARY NOTES The views, opinions and/or findings contained in this report are those of the author(s) and should not be construed as an official Department of the Army position, policy or decision, unless so designated by other documentation.				
12a. DISTRIBUTION / AVAILABILITY STATEMENT Approved for public release; distribution unlimited.			12 b. DISTRIBUTION CODE	
13. ABSTRACT (Maximum 200 words) Spatial-phase-locked electron-beam lithography (SPLEBL) is a novel approach to achieving very high pattern-placement accuracy, and precision, in electron-beam lithography. The accuracy achieved by SPLEBL is essential in order to enable the continuation of next-generation lithography techniques to below 20-nm feature sizes.				
14. SUBJECT TERMS			15. NUMBER OF PAGES	
			16. PRICE CODE	
17. SECURITY CLASSIFICATION OR REPORT UNCLASSIFIED	18. SECURITY CLASSIFICATION OF THIS PAGE UNCLASSIFIED	19. SECURITY CLASSIFICATION OF ABSTRACT UNCLASSIFIED	20. LIMITATION OF ABSTRACT UL	

quickly lost. For example, the best conventional EBL tools can only achieve a pattern-placement accuracy of 30 nm, which is unacceptable for lithography at 100 nm and smaller.

In SPLEBL a fiducial grid is placed on the substrate, and this grid provides a direct reference of the e-beam while patterns are being written. The basic paradigm of SPLEBL is depicted in Figure 1. The interaction of the scanning e-beam with the fiducial grid generates a modulated signal, and this signal can be processed to deduce the precise position of the e-beam on the substrate. The precision with which the e-beam can be located is expected to be below 1 nm in a well-designed system. Thus, a SPLEBL system offers the promise of achieving 1-nm-level pattern-placement accuracy.

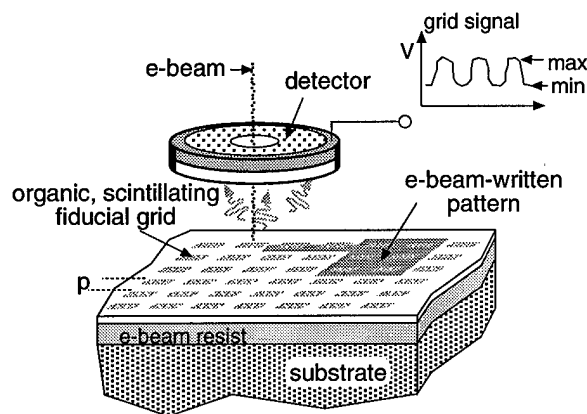

Figure 1. Spatial-phase-locked electron-beam lithography is capable of achieving 1-nm pattern-placement accuracy. The periodic signal, produced by the interaction of the electron beam with a fiducial grid on the substrate, provides precise information about the beam's position at all times.

Detailed summary of tasks:

1. Measurement of secondary-electron signals.

The ultimate pattern-placement accuracy achieved using SPLEBL depends upon several parameters. One critical parameter is the quality of the signal produced by the fiducial grid on the substrate. The first proposed implementation of SPLEBL called for the use of thin metallic fiducial grids patterned by interference lithography. These grids are expected to produce a modulation in the backscattered or secondary electrons. Experiments were carried out to measure the modulation contrast, i.e. maximum-to-minimum signal ratio, from thin metallic grids, Figure 2(a), and lattices, Figure 2(b), composed of different metals. The measurement results are summarized in Table 1. Measurements were made using a scanning-

electron microscope operated at 20kV and an in-lens secondary-electron detector. The contrast was found to be highest for the grid design.

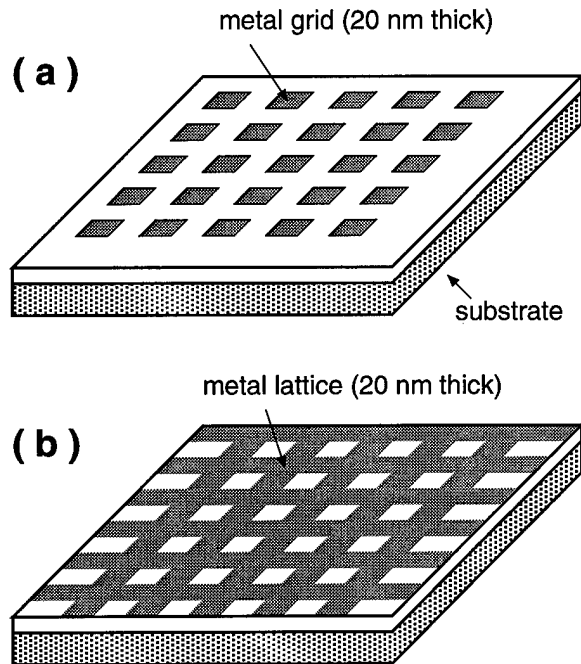

Figure 2. The interaction of the scanning-electron beam with thin metallic grids (a) and lattices (b) resulted in a modulation of the secondary-electron signal. The measured values of this modulation contrast, i.e. maximum-to-minimum ratio, are reported in Table 1.

Table 1. Secondary-electron modulation contrast.

material	contrast (lattice)	contrast (grid)
Au	1.14	2.28
Ni	1.18	
Cr	1.07	1.91
Al	1.56	

The contrast values measured for the aluminum lattice and chrome grid are suitable for achieving precise pattern placement, as will be described in Task 3. It must be noted that a SPLEBL system based on the use of thin metallic fiducial grids or lattices will require an in-lens secondary-electron detector.

2. Experimental demonstration of 1-D, real-time SPLEBL using an external delay-locked loop.

Under previous funding, a segmented-grid mode of SPLEBL was developed. In this mode, small segments or patches of fiducial grids are located in the corner of the e-beam fields. Before writing patterns in a field, the segments are scanned to evaluate the e-beam position precisely. The scanning routine is similar to that used when aligning to field-registration marks, however the segmented mode of SPLEBL enables more precise alignment and pattern placement, i.e. sub-8 nm. This mode of SPLEBL was used to successfully pattern gratings on top of waveguides, which extended over many e-beam fields, and the measured performance of these integrated-optical devices showed no transmission induced by poor e-beam-field stitching.

The segmented mode of SPLEBL is not the most general and flexible mode of SPLEBL. The area on the substrate occupied by the grid segments is unusable for subsequent processing. A more general mode of SPLEBL, the global-fiducial-grid mode, was initiated for 1-D during this program. In this mode of SPLEBL, the fiducial grid is located everywhere on the substrate, but the grid is thin, i.e. mostly transparent to the e-beam, so that it does not effect the lithography. However, the grid is substantial enough to provide a weak signal which can be used to track the position of the e-beam at all times, and at all positions on the substrate.

An external analog delay-locked loop (DLL) was developed for the first implementation of the global mode of SPLEBL in 1-D. A schematic of the DLL is shown in Figure 3. As the e-beam interacts with the global grid, producing a periodic signal (see Fig. 1), this DLL tracks the phase of that signal precisely. The DLL operates much like a phase-locked loop. The DLL ran externally and in parallel to the e-beam system, i.e. it continually tracked the grid-signal phase and made fine field-shift corrections. Demonstrations of the DLL were carried out in real time, Figure 4, and in a field-stitching experiment, which is summarized in the results of Table 2.

The stitching experiment, carried out under non-optimized conditions, showed that the mean-plus-sigma, $\mu + \sigma$, stitching precision improved by a factor of 6 when the DLL was used for the global mode of SPLEBL. In this experiment, the signal from the global-fiducial grid was noisy and very low in contrast due to system limitations. Current research efforts are directed at improving the quality of the fiducial-grid signal.

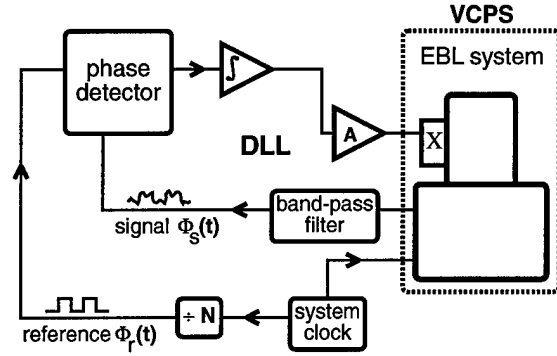

Figure 3. This schematic describes an external delay-locked loop (DLL) which was used for the global-fiducial-grid mode of SPLEBL. This loop tracks precisely the phase of the modulated signal from the fiducial grid. The DLL consists of a band-pass filter, phase detector, integrator and amplifier. The electron-beam lithography (EBL) system itself acts as a voltage-controlled phase shifter (VCPS). In this demonstration, the phase of the grid signal is locked to the phase of the system clock. This assures that pattern generation, triggered off the system clock, is referenced to the phase of the fiducial grid.

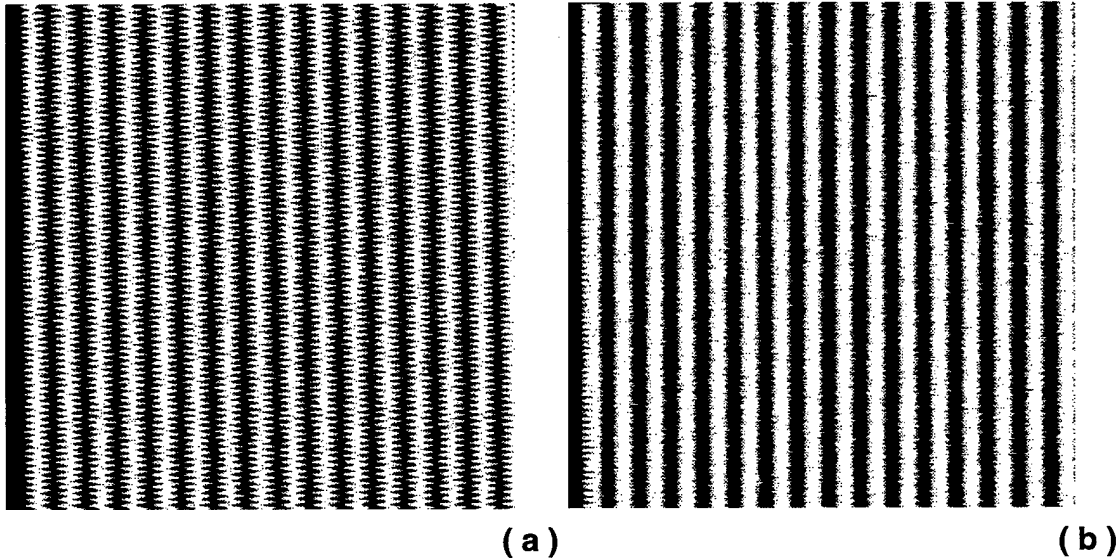

Figure 4. The recorded images of a metallic grating demonstrate the real-time operation of SPLEBL with the DLL. In (a) a 60Hz electromagnetic field was deliberately coupled into the e-beam column. The periodic deviation of the e-beam produced a distorted image of the grating (period = 400 nm). In (b) the DLL cancelled the undesirable stray field, and demonstrates the effectiveness of real-time feedback with SPLEBL.

Table 2. Field-stitching results with the delay-locked loop.

	μ (mean stitching error)	σ (uncertainty)
SPLEBL	0.6 nm	7.7 nm
EBL	26 nm	23 nm

3. Numerical simulation of 1-D SPLEBL using a DLL.

A numerical model of spatial-phase-locked electron-beam lithography was developed to verify the effectiveness of the delay-locked loop, and evaluate the ultimate performance of a well-designed SPLEBL system, i.e. a system with a high-quality fiducial-grid signal. The numerical model emulated the action of the DLL, and incorporated other system parameters such as signal noise and the effect of the e-beam's convolution with the fiducial grid. Additionally, a semi-analytic model was derived based primarily on Poisson noise considerations from the electron-beam tool. Results from the numerical and semi-analytic model are summarized in the graph of Figure 5. Results from the field-stitching experiment are also included in the graph

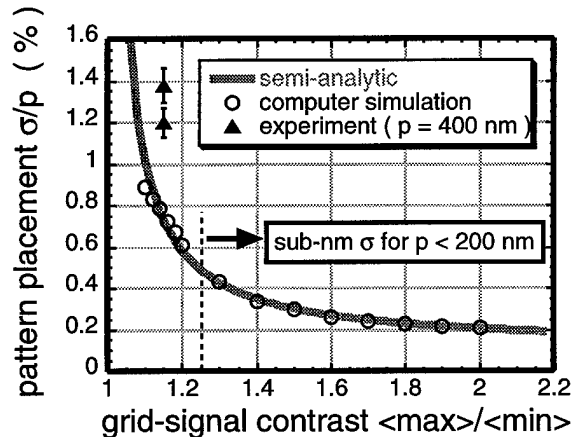

Figure 5. Results from a numerical simulation and semi-analytic model show that higher signal contrast from the fiducial grid significantly improves the pattern-placement accuracy achieved with SPLEBL. For a grid period, p , less than 200 nm and a signal contrast greater than 1.25, sub-nm pattern-placement accuracy can be achieved. The graph also shows the non-optimal signal used for the experiment and results reported in Table 2.

Results from the numerical simulation of SPLEBL emphasize the benefit of obtaining a higher-quality signal from the global-fiducial grid. Improving the quality of this signal is challenging, since increasing the physical structure of the grid

can adversely effect the e-beam lithography, i.e. induce excess electron scattering. Careful consideration of electron scattering and improved signal quality resulted in a new design for the global-fiducial grid.

4. Development and calibration of a field-stitching measurement routine.

The goal of this research program is to demonstrate sub-nm pattern-placement accuracy. In order to verify placement accuracy, it was necessary to develop a measurement routine capable of detecting sub-nm placement errors. An experimental procedure and algorithm for an EBL system was developed which enabled precise measurement of stitched grating segments. This routine enables determination of field-stitching precision and pattern-placement accuracy, with respect to the fiducial grid, to the sub-1 nm level.

The procedure for evaluating field stitching requires EBL patterning of grating segments at the edges of adjacent fields. There is an intentional gap between the grating segments so that the field boundary can be identified. Figure 6(a) depicts the layout of the grating segments, and Fig. 6(b) shows an SEM image of actual stitched gratings. The grating segments are typically 5 μm wide by 10-20 μm long, and the grating pitch is 400 nm or less

Once the gratings have been written with SPLEBL and processed further, i.e. plated in gold, the sample is loaded back into the EBL system for inspection. An algorithm was developed which centers the stitched gratings in the viewing field, extracts the spatial phase of the grating segments on each side of the field boundary, and calculates the spatial shift between the two gratings. The spatial phase of each grating is determined by 64 lines of data, 512 samples/line, so that sub-nm detection of spatial shift is possible. Additionally, at least 100 stitched fields are written so that a histogram of stitching errors, mean and standard deviation, can be composed. This measurement routine was used to acquire the data reported in Table 2.

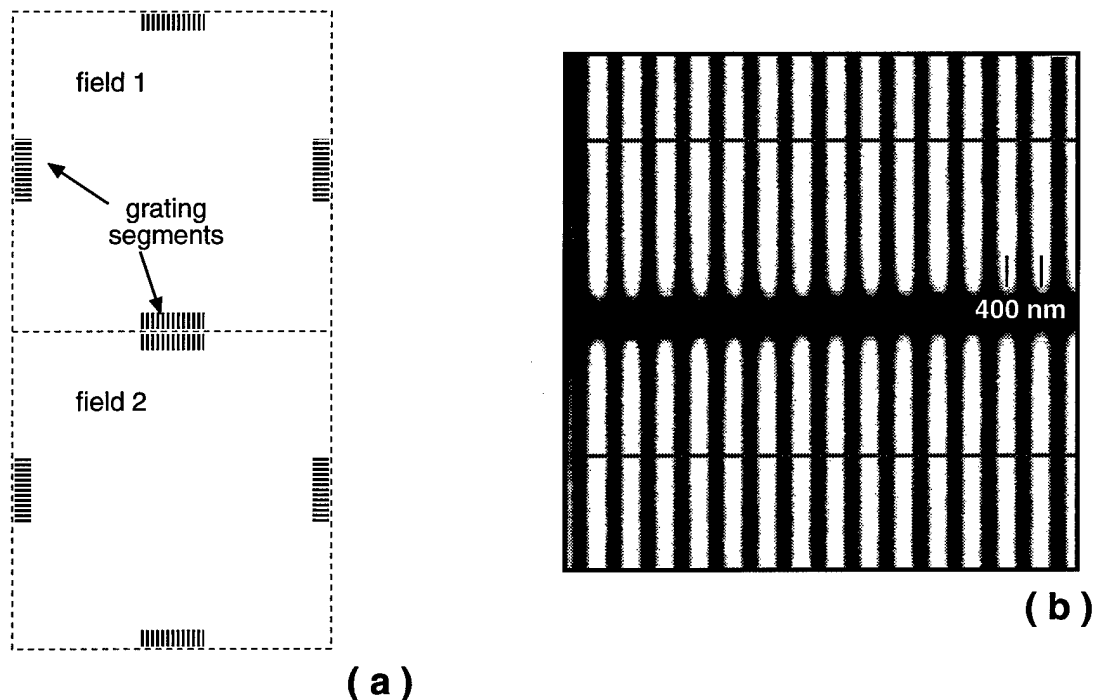

(a)

Figure 6. Grating segments were patterned near the edge of the e-beam field (a) in order to evaluate the field-stitching precision. A careful inspection of the paired grating segments (b) enables an evaluation of field-stitching precision at the sub-1 nm level. The horizontal lines in (b) indicate the e-beam scan path used to extract the spatial phase of each grating segment. Each segment was scanned 64 times to extract the spatial phase.

5. Design of a 2-D DLL for real-time SPLEBL

After completing the 1-D demonstration of SPLEBL using a delay-locked loop, a new analog circuit was designed for the real-time, 2-D, global-grid mode of SPLEBL. A block diagram of the circuit is shown in Figure 7. This circuit consists of two DLL's, i.e. one for each spatial axis, and is designed for a raster-scan e-beam system. In order to operate properly, the circuit requires two different spatial frequencies for the global grid, i.e. one distinct frequency for each spatial axis. Also, the grid must be scanned at an angle of about 45 degrees, so that the spatial position errors for each axis could be updated at similar rates. Since the e-beam scans the fiducial grid at an angle, the modulated signal from each axis of the grid is multiplexed onto the same signal. The position information for each axis is retrieved by filtering the signal. A high-Q filter picks out the particular frequency of interest for a spatial axis. However, the high-Q filters significantly slow the circuit response, and do not completely filter out the nearby signal from the other axis. Because of these problems and the significant increase in complexity of the circuit, the efforts on developing an analog SPLEBL scheme were postponed in favor of pursuing a digital-signal-processing (DSP) scheme. The DSP scheme also offers greater flexibility in circuit design, and enables rapid iterative development. One DSP approach is reported in Part 10.

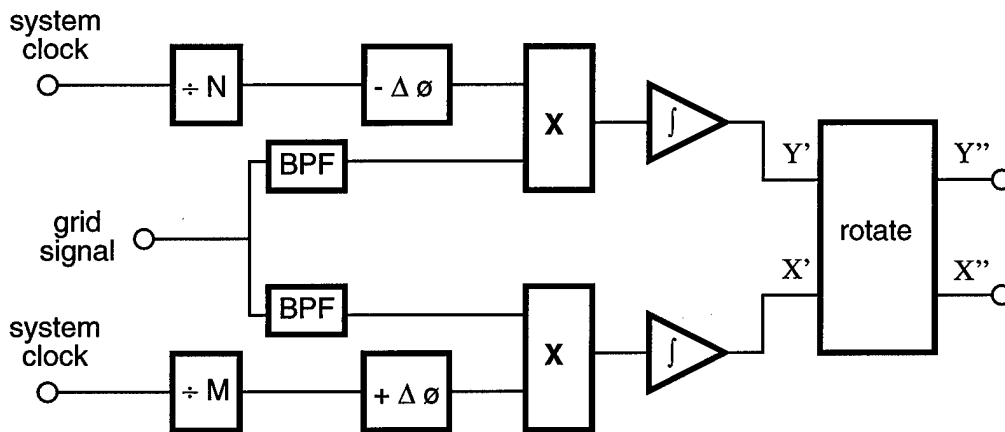

Figure 7: The design of a circuit for the real-time, 2-D, global-grid mode of SPLEBL is shown in this block diagram.

One axis of the 2-D circuit was tested on a 400-nm-period grating oriented at 45 degrees. Stable locking was obtained in real time, and the acquire-lock time was longer than the 1-D circuit as expected. The full circuit was tested on a two-period fiducial grid, i.e. 4 μ m period in X and 6 μ m period in Y. Locking was achieved, but the stable operating window was limited in frequency and amplitude range. The limited operating range was partly due to the small number of periods used in the e-beam field. More stable operation is expected with a modification of the circuit and the use of finer-pitched grids.

6. Monte-Carlo simulation of electron scattering.

One version of the global-grid mode of SPLEBL called for the patterning of a metallic grid over the e-beam resist, and the use of secondary electrons to detect the modulated grid signal. For example, a 20-nm-thick chrome grid could be patterned over the resist using interference lithography or near-field lithography, and an in-lens secondary-electron detector could be used to monitor the grid signal. Previous measurements under these conditions, see Section 1, Table 1, indicated that an ample signal would be obtained.

Having a metallic grid over the resist presented the possibility of reduced pattern fidelity due to non-uniform electron scattering. For example, a line written in resist covered with the chrome might be broader than a line written where no chrome

covers the resist. The broadening might result from additional electron scattering as the e-beam passes through the thin chrome layer.

The effect of fiducial-grid-induced scattering was investigated with a Monte Carlo e-beam exposure simulator that was developed at MIT. The simulator traces the trajectories of electrons passing through layers of material, and records the cumulative electron dose deposited at discrete depths in each layer. This simulator was used to compare the cumulative dose for an electron-beam exposure in resist with, and without, an overlying fiducial grid. An example of e-beam point-dose distributions with, and without, a 20-nm Cr fiducial grid is shown in Figure 8. The dark points represent the distribution when the e-beam does not pass through the Cr overlayer, and the open circles show the distribution for a beam passing through the Cr overlayer. The graph shows little variation in the e-beam dose profile when the fiducial grid is present.

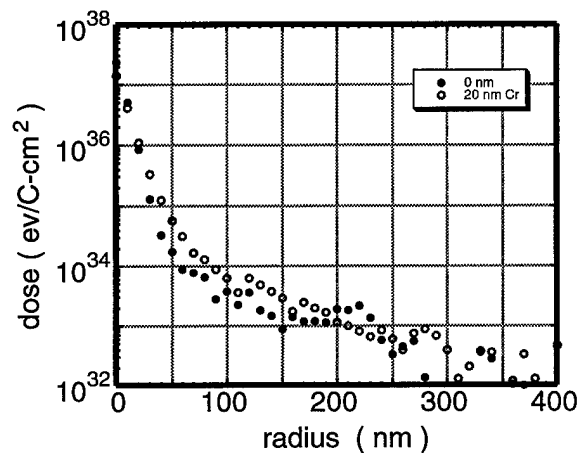

Figure 8. This graph shows the simulated e-beam point-dose distribution without (filled circles) and with (open circles) a 20-nm-thick Cr overlayer, as would be used for one version of the global-fiducial grid. The electron energy was 50 kV, and the electron-beam diameter was taken as 20 nm. 100,000 electron trajectories were used to obtain each curve.

After the point-dose distributions were obtained, these e-beam profiles were convolved with fine line and grating patterns in order to determine whether an overlying fiducial grid would cause significant linewidth variations. These simulations showed width variations less than 10% for 100-nm-wide lines written through fiducial grids of the following design: a 20-nm thick Cr grid, a 20-nm thick Al grid, and a 150-nm-thick organic polymer grid. The width variations were less than 5% for 200-nm-pitch gratings. Also, experiments were carried out where a 150-nm thick polymer grid was patterned over the e-beam resist before e-beam exposure. Several fine patterns were written through the fiducial grid, and no pattern

degradation was observed. (See Section 8 for information about the use of a polymer for the fiducial grid.)

7. Survey of high-speed dose-modulation schemes for real-time SPLEBL.

The implementation of real-time SPLEBL, i.e. maintaining continuous tracking of the fiducial grid while writing patterns, requires the use of a high-speed dose modulator. This dose modulator permits full dose while exposing patterns, but only passes a partial dose while the beam moves between patterns. The partial dose is low enough so that the e-beam resist is not exposed, but high enough to provide the necessary grid signal required for SPLEBL. The modulator must be able to switch between the two dose levels rapidly, ideally in about 1 ns.

A survey of dose-modulation schemes was carried out to determine the most suitable scheme for SPLEBL. Methods investigated included (1) partial-beam blanking, (2) optically-modulated electron sources, (3) electrically-modulated electron sources, and (4) quadra-deflection with a variable beam aperture. For schemes (1)-(3), source stability, regarding emission current or position, was problematic. Switching speed was also inadequate for one version of (2), i.e. optically-excited field-emission tips. Another version of (2) based on negative-electron affinity cathodes promised the requisite switching speed, but the cathode lifetime was inadequate. Only the quadra-deflection method satisfied the requirements for a SPLEBL system.

The quadra-deflection dose modulator is depicted in Figure 9. This modulator consists of four parallel-plate deflectors, which pull a short section of the electron beam off axis by a small amount, i.e. $< 500 \mu\text{m}$. The deflection is symmetric about the center of the plates, where an aperture strip is mounted. The aperture strip has a large opening, to pass a full e-beam dose, lying on the beam axis, and a small opening lying slightly off axis. The small opening passes a partial dose when the beam is deviated off axis. Preliminary design and modeling suggests that the quadra-deflector can achieve 1 ns switching speeds for an applied voltage of $\pm 5 \text{ V}$ to the deflection plates and an electron-beam energy of 10 kV. A prototype quadra-deflector is currently being assembled, so that high-speed dose-modulation tests can be carried out.

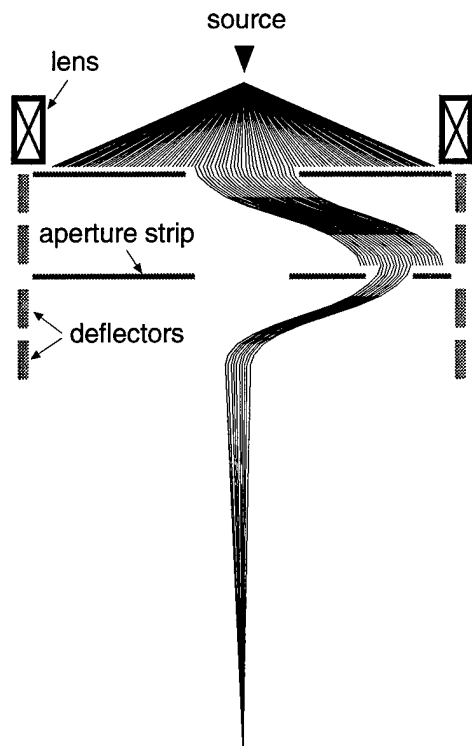

Figure 9. This drawing depicts the high-speed, quadra-deflection dose modulator required for real-time SPLEBL. Four parallel-plate deflectors are used to rapidly move the e-beam between a large aperture on axis and a small aperture off axis. The aperture size determines the dose level delivered to the substrate. In this figure, the horizontal axis is highly magnified. Switching speeds can be as short as 1 ns with the quadra deflector.

8. Development of a scintillating polymer suitable for use as a global-fiducial grid.

A quality signal from the fiducial grid is highly important for precise pattern placement via SPLEBL. Signal noise and low contrast increase the uncertainty in determining the precise position of the e-beam on the fiducial grid. To improve the signal quality, a new fiducial-grid design was proposed and investigated. This grid is based upon the use of scintillating organic polymers, i.e. materials which emit light when struck by high-energy electrons. Advantages of the scintillating grid include increased signal contrast and higher signal yield. The signal contrast increases because photons are not emitted from regions between scintillating grid points, unlike secondary-electron emission which comes from everywhere on the substrate. The signal level increases because one high-energy electron can create many photons, whereas it typically creates one, or fewer, secondary electrons. Thus, the scintillating fiducial grid can improve the signal quality and increase the e-beam patterning accuracy.

Both a literature search and experimental survey of a limited set of scintillating compounds were carried out in an effort to identify a suitable polymer mix that could be used to fabricate a scintillating fiducial grid. One mix was developed which had suitable properties, i.e. high signal output, long shelf life, ease of application, ability to pattern down to the 100-nm level. This mix consists of a host polymer, PMMA, with scintillating compounds in suspension. The compounds in suspension are naphthalene, anthracene, and POPOP. A highly desirable characteristic of this scintillator is that a fiducial-grid pattern could be quenched in a thin film of the scintillator by two exposures to interfering ultraviolet radiation. After the exposures, the uniformly-thick film had scintillating and non-scintillating regions in the pattern of a grid. Since the film is uniform and of low atomic number, it also minimally affects e-beam lithography (see Section 6).

A modulated optical signal was measured from a scintillating fiducial grating, and is shown in Figure 10. The grating was patterned by the UV-quenching process described above (only one exposure required). After quenching, the sample was scanned with the e-beam of a scanning-electron microscope (SEM). The interaction of the scanning beam with the scintillating grating produced a modulated optical signal which was detected with a photomultiplier tube mounted inside the SEM's specimen chamber. The graph shows a high signal contrast, i.e. maximum-to-minimum signal ratio, of 2.8. According to previous simulations of SPLEBL, this signal would enable a locking precision of less than 0.2% of the fiducial-grid period (refer to Fig. 5). Further improvements are being made to the scintillating polymer to facilitate its use as a global-fiducial grid.

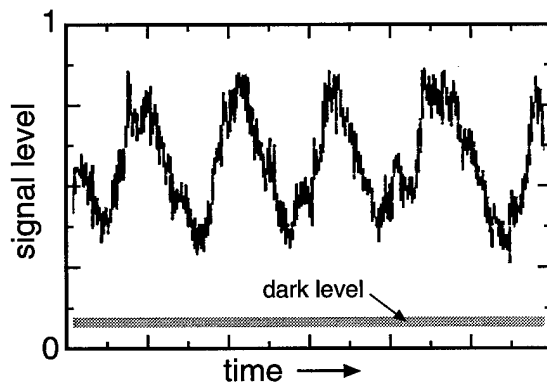

Figure 10. This signal was recorded from a 2- μ m-period, organic, scintillating fiducial grating. An electron beam scanned the grating and a photomultiplier tube detected the modulated optical signal. The signal contrast (maximum-to-minimum ratio) was measured to be 2.8. This value is significantly higher than that obtainable from a fiducial grid designed for secondary-electron emission. The use of an organic scintillator is preferred over the use of metals for the fiducial grid.

9. Initial assembly of a bench-top e-beam column.

The development of the high-speed electron-beam dose modulator required the use of a compact, experimental electron-beam column. The column would house the quadra deflector (see Section 7), electron-optical lenses, and necessary measurement and diagnostic apparatus. This column would enable rapid testing of quadra-deflector designs without disabling an e-beam lithography tool for the testing period.

Construction of a bench-top test column began during this program. The column, shown in Figure 11, could achieve a vacuum of 1×10^{-7} Torr. Although the vacuum was not low enough to permit operation of field-emission electron sources, emission was obtained using a tungsten filament. Beside the test column is shown a V-rail used to mount the electron-optical lenses and the quadra deflector. The parallel plates of the quadra deflector have been separated for the photo. Further experiments with the test column and quadra deflector will be carried out shortly.

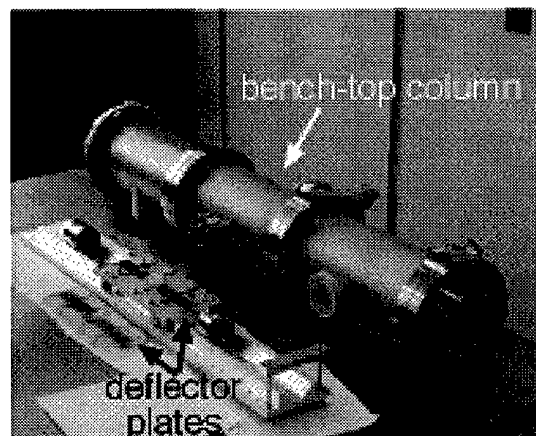

Figure 11. This bench-top electron-beam column was assembled to test the quadra deflector, which is shown on the table beside the column. A V-rail is used for approximate alignment of the electron source, quadra deflector and electron-optical lenses inside the column. Electron emission was obtained with a tungsten filament source.

10. Development of a 2-D sparse-sampling algorithm for SPLEBL.

The sparse-sample mode of spatial-phase locking implements a "look-then-right" procedure with a global fiducial grid. Before writing, the grid is sparsely

sampled with the electron beam at a dose well below the resist development threshold. The sparse-sample points define a second grid whose period differs slightly from the period of the fiducial grid on the substrate. A moiré pattern results, and the moiré spatial frequency in a given direction is the difference between the sparse-sample and fiducial grid spatial frequencies. For example, a 512x512 sample array of 520x520 grid periods in x and y yields an 8x8 moiré grid pattern. This is also true for higher-order aliasing; i.e. 512x512 samples of 1032x1032 periods. Figure 12 shows simulated moiré patterns as described above.

Because the spatial phase of the moiré pattern is equal to the phase difference between the underlying fiducial grid and the sample grid, one can extract the field's shift with respect to the fiducial grid and any scaling error, rotation, or trapezoidal distortion. Once the errors are determined, the appropriate corrections are fed back to the beam deflection system before exposing the desired pattern. This process is repeated for each field in the pattern, and requires that the e-beam stage and deflection system position the field only within one fiducial grid period of the desired location. However, the "look-then-write" procedure requires system stability for the duration of the field exposure.

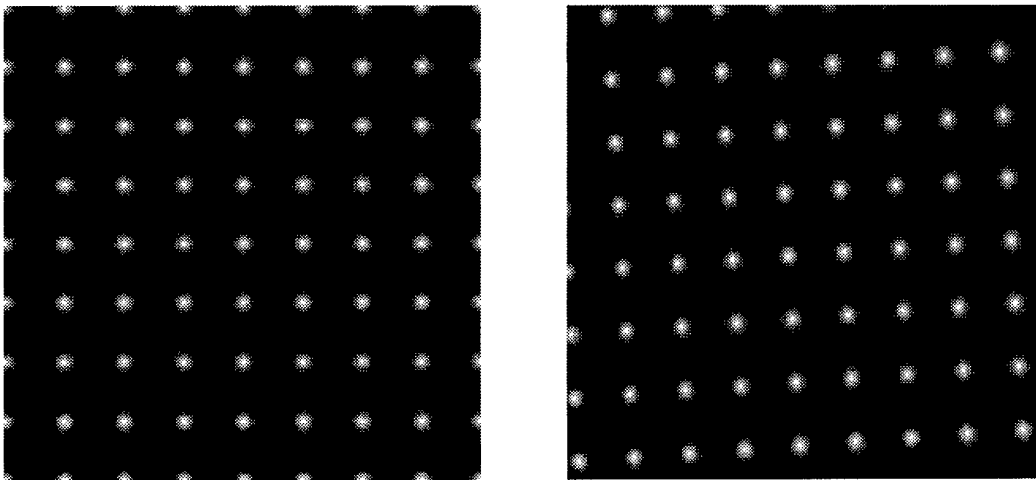

Figure 12: (a) A perfectly aligned moiré pattern, generated by a 512x512 sparse sample of a 520x520 period grid, is shown. (b) The presence of e-beam field rotation, shift and scaling errors distorts the moiré pattern as shown.