

IDA

INSTITUTE FOR DEFENSE ANALYSES

**Civil-Military Emergency Planning Council
Denver Conference Proceedings**

A. Martin Lidy
M. Michele Cecil
Edward F. Smith, Jr.

May 2000

Approved for public release;
distribution unlimited.

IDA Document D-2439

Log: H 00-000480

20000719 032

DTIC QUALITY INSPECTED 4

This work was conducted under contract DASW01 98 C 0067, Task BB-9-1759, for the DoD Project Officer for International Civil-Military Emergency Planning. The publication of this IDA document does not indicate endorsement by the Department of Defense, nor should the contents be construed as reflecting the official position of that Agency.

© 2000 Institute for Defense Analyses, 1801 N. Beauregard Street, Alexandria, Virginia 22311-1772 • (703) 845-2000.

This material may be reproduced by or for the U.S. Government pursuant to the copyright license under the clause at DFARS 252.227-7013 (NOV 95).

INSTITUTE FOR DEFENSE ANALYSES

IDA Document D-2439

**Civil-Military Emergency Planning Council
Denver Conference Proceedings**

A. Martin Lidy
M. Michele Cecil
Edward F. Smith, Jr.

PREFACE

This document was prepared by the Institute for Defense Analyses (IDA) in partial response to the task "Civil-Military Emergency Planning Workshop Support" sponsored by the DoD Project Officer for International Civil-Military Planning, funded by the Office of the Assistant Secretary of Defense (International Security Affairs). This document serves as a summary record for the Civil-Military Emergency Planning Council Conference held in Denver, Colorado, 21-26 February 2000.

The document was reviewed by the IDA personnel who attended the Denver Conference and by the Director of the Operational Evaluation Division, Mr. Thomas P. Christie.

**CIVIL-MILITARY EMERGENCY PLANNING COUNCIL
DENVER CONFERENCE PROCEEDINGS**

A. Background	1
B. Summary	3
1. Policy Session One.....	3
2. Policy Session Two	5
3. Policy Session Three	6
4. Policy Sessions Four and Five	9
5. Policy Session Six	10
6. Action Items	11
C. Conclusions.....	11

Appendix A - Conference Introduction Brief

Appendix B - Bulgarian Concept Brief

Appendix C - Regional Disaster Organizations Brief

Appendix D - Second Draft Charter of Southeastern European Civil-Military
Emergency Planning Council

Appendix E - Schedule of Activities

Appendix F - Attendees

Appendix G - Wrap-Up Briefing

List of Figures

1. Possible Organizational Structures and Purposes.....	7
2. Participants' Consensus of Council's Structural Purpose	8

CIVIL-MILITARY EMERGENCY PLANNING COUNCIL DENVER CONFERENCE PROCEEDINGS

A. BACKGROUND

The U.S. Department of Defense (DoD) has been engaged in the Partnerships for Peace (PfP) program formed by the North Atlantic Treaty Organization (NATO) since 1990. One small but important element of this engagement program is the use of the Civil-Military Emergency Planning (CMEP) initiative to enhance the capabilities of the PfP Partners to work with each other, with neighboring nations, and with the international community to prepare for natural and technological disasters within any Partner nation.

The CMEP initiative includes a number of events, such as traveling contact teams from the U.S. and familiarization tours to the U.S., as well as several workshops conducted both in the U.S. and in Partner nations. This initiative familiarizes professional civilian and military "emergency managers" of Partner nations with the legal foundations, planning guidelines, and operational procedures that govern use of the U.S. Armed Forces when providing support to U.S. civil authorities. The CMEP initiatives also provide familiarization with evolving computer-based techniques of emergency information planning and management, and seek to build on an incremental basis an enduring competence within the Partners' organizations. The computer related familiarization includes: data base structures, internet research and simulations, and geographic information systems.

In 1996, the U.S. Secretary of Defense determined that DoD's CMEP initiatives should be applied in a focused effort to build enduring regional capabilities for cooperation in emergency preparedness and response. At that same time the U.S. DoD encouraged regional cooperation by supporting the development of the Southeastern Europe Defense Ministerial (SEDM). The SEDM group currently includes the PfP Partner nations of Albania, Bulgaria, Former Yugoslav Republic of Macedonia (FYROM), Romania, and Slovenia, plus NATO Member nations Greece, Italy, Turkey, and the United States. As these Defense Ministries were already working to achieve regional solutions, it was natural for the CMEP initiative to include the same countries.

The first regional event for the CMEP group was a seminar hosted by Macedonia in 1996. In 1998, this CMEP group was introduced to the U.S. emergency management system during a series of seminars in Memphis, Tennessee. In December 1998, the first Partner-hosted workshop was conducted in Slovenia. The second Partner-hosted workshop was held in Varna, Bulgaria in September 1999.

Varna was a precedent-setting event; it included a technical workshop and a plenary session. The technical workshop emphasized emergency response procedures with emphasis on information and communications systems. The plenary session included leaders and senior representatives from civil protection and defense ministries from most SEDM nations, other PfP Partners, the United Nations Office for the Coordination of Humanitarian Affairs (UNOCHA), the Euro-Atlantic Disaster Response Coordination Center (EADRCC), the Council of Europe, and NATO's Civil Emergency Planning Office. During the plenary session, the Bulgarian host, MG Nikola Nikolov, proposed that the nations of the SEDM region establish a Civil-Military Emergency Planning Council (CMEPC). The council's role would be to establish the policies and priorities needed to facilitate greater cooperation among SEDM nations in the area of CMEP. This proposal was strongly supported by the senior representatives during the plenary session.

To assist with establishing the CMEPC, the Governor of the State of Colorado and the Colorado National Guard, through the National Guard State Affiliation Program, invited the heads of civil protection and appropriate military representatives of the SEDM region to Denver in February 2000. The Governor wanted to provide the invited delegates the opportunity to discuss the proposed council and steps needed in forming it.

Before the Denver Conference, the Institute for Defense Analyses (IDA) provided each delegation with:

- a draft council "charter,"
- the agenda for the policy sessions, and
- supporting materials for the policy sessions.

During the week, the Colorado National Guard established a cooperative atmosphere by inviting the delegates to attend a variety of events. The events included contacts with numerous Colorado businesses, state and local elected officials, and state and local disaster managers. IDA facilitated the delegates' discussions during the policy sessions, utilizing volunteer facilitators and a professional recorder from the Colorado

community. The Colorado National Guard also provided essential logistical assistance to ensure the success of the policy sessions.

B. SUMMARY

This document summarizes the six policy sessions conducted during the conference and serves as the record of the conference. The document also includes the following appendices: the Conference Introduction briefing; the list of attendees; a summary schedule of events; the Regional Disaster Organizations briefing; the Bulgarian Concept briefing; the Second Draft CMEPC document; and a wrap-up briefing.

1. Policy Session One

Mr. Martin Lidy of IDA opened Policy Session One by establishing the conference purpose and explaining the approach IDA would take in facilitating the conference.¹

During Policy Session One, delegations from Turkey, Slovenia, Romania, FYROM, Greece, Bulgaria, and Albania introduced their national emergency response capabilities, and established a common understanding of regional capabilities by answering the following questions:

- What national emergency response capabilities exist within the SEDM Region?
- Which national agencies (civilian and military) have resources to respond to a large-scale disaster?
- How are resources controlled by national authorities for disaster response?
- How do the national authorities coordinate with local authorities? How do national authorities coordinate with non-governmental organizations (profit and non-profit organizations)?
- Are national and local resources recorded in computerized databases, if any? Where do the databases reside? Who updates them? Who has access to them?

The briefings demonstrated to the group the many similarities and a few differences among the national emergency management systems.

¹ See Appendix A for Mr. Lidy's briefing.

Many countries reported that they are currently reviewing their policies and procedures because of their experiences in recent disasters. The countries are focusing their efforts to change communication mechanisms and develop better computer support. Each country is seeking innovative technology for rapid and efficient disaster response.

The role of the national military varies in disasters in each of the countries. Some countries have limitations on how military assets can be used, while other countries use them liberally. In some countries the military is the primary manager of national disasters, while in other countries the civilian agencies have lead responsibility.

There are also different levels of emergency response capabilities in each country. There are different degrees of preparedness in governmental administrative structures and laws, that can limit the effectiveness of responding organizations. Several delegations commented that there is much to be learned through information exchange and technical cooperation among the nations of the SEDM region.

The second part of this policy session was spent discussing Bulgaria's proposal for the region. MG Nikola Nikolov presented Bulgaria's concept of the CMEP Council.² MG Nikolov stated that there was a need for a permanent regional organization to plan for and respond to disasters. He stressed that the way ahead was cooperation among the countries in the region with the support of EADRCC and UNOCHA. He explained that numerous administrative details must be worked out before the council could be realized. During this work, the delegates were encouraged not to lose sight of the ultimate goal: providing assistance to the disaster victims.

After MG Nikolov's briefing the delegates discussed how they could achieve a meaningful CMEPC. The delegates agreed that there was a need for the CMEP Council, and the earlier briefings reinforced their awareness of this need. They agreed they needed a document to record the CMEPC's organization, structure, and protocols. IDA reminded the delegates that it had prepared such a document for the delegates' review before the conference. Several delegates stated they had reviewed the IDA "Draft Charter" and had prepared changes and comments. The delegates agreed to focus their efforts on revising the IDA drafted charter. One delegate stated that cooperation in the emergency management sector could be used as a good example for other sectoral cooperation in the Southeastern European region.

² See Appendix B for MG Nikolov's briefing.

2. Policy Session Two

Policy Session Two opened with a suggestion that the delegates draft the purpose of the organization and examine the possible programs for the organization. Ms. Michele Cecil of IDA presented some examples of programs from other organizations.³ She explained that the programs of other regional disaster organizations revolve around the four stages of the disaster management cycle:

- Mitigation
- Preparedness
- Response
- Recovery.

After some discussion, one delegation said that it was important for the proposed council to reflect the needs and experiences of their own region. In response, the other delegates agreed it was important to continue explaining their own recent experiences.

During Policy Session Two, the delegates from Albania, Greece, FRYOM, and Turkey explained for the group how international assistance was received and coordinated during recent disasters by answering the following questions:

- How can regional cooperation be improved when receiving international disaster assistance?
- Was assistance requested or was it automatically given? Did things requested arrive? Could the assistance that was provided be used? Was any assistance turned away?
- Did bilateral agreements work? Who was responsible for implementing them?
- What was the experience with information sharing and coordination with the international community (other nations, UN, and NGOs)? What types of information were provided? Was the international community asked for information, and did they provide what was requested?
- What was the experience with integrating the international civilian agencies and international military agencies into the national response?
- What were the strengths and weaknesses in the system when receiving international assistance?

³ See Appendix C and Policy Session Three where the other regional organizations are explained in more detail.

The delegates emphasized that civil protection organizations are not the only resource for disasters. The Defense Ministries, Customs authorities, Ministries of Foreign Affairs, and other ministries play important roles during disaster response. The affected country must be able to coordinate effectively the population's needs with the assistance from domestic and international organizations. The delegates asserted that the existing coordination mechanisms made it possible to respond but there was much room for improvement.

Regardless of whether disasters are natural or manmade, affected populations face a set of common needs: housing, food, and economic assistance. The delegates suggested that the proposed CMEPC should work on mechanisms that could effectively and efficiently fulfill those common needs. Most importantly, the delegates emphasized that the recent success in responding to an affected population's needs was depends on the generosity and humanitarianism of the people in the region.

In responding to a disaster the first rule is: "Do no harm." Delegations reported that during the SEDM region's recent disasters, some responders failed to follow this rule. The recent failures included: sending expired medicines, inequality in treatment of victims by outsiders, and over-reliance on bureaucratic procedures despite the immediacy of dying disaster victims.

The discussion during Policy Session Two developed further consensus on the need for a Southeastern European regional disaster organization and highlighted possible objectives of the organization. The delegates proposed that a regional council would be the perfect venue to share the lessons from disasters and begin to prepare and plan for future disasters together.

3. Policy Session Three

Policy Session Three opened with questions on the purpose of the CMEP Council and what it should do. Michele Cecil, facilitator from IDA, presented the delegations with several options to consider.⁴

Each delegation was given the opportunity to explain what they thought the purpose of a regional disaster preparedness organization should be. They generally agreed that the Council must focus on the entire disaster management cycle: mitigation, preparedness, response, and recovery.

⁴ See Appendix C for her briefing.

Each delegation emphasized that the organization should reflect an informal organizational structure rather than a formal, complex structure. Several delegates suggested that a formal structure was not possible since their governments would not agree to an “international super structure” that could impose orders or commands on the member states. The delegates were very sensitive to an organization that could interfere in the member states’ sovereignty.

When deciding the purpose of the regional disaster organization, the delegates also spoke in terms of defining the programs and activities of the organization. The facilitators presented a number of programs ranging from informal information sharing to fully integrated disaster response activities. Generally the delegates agreed that the council should:

- Share information or lessons with each other
- Exchange information about national capabilities
- Plan for future disasters
- Practice response procedures for regional disasters.

The facilitators drew the diagram shown in Figure 1 for the delegates. Ms. Cecil provided them with two examples.

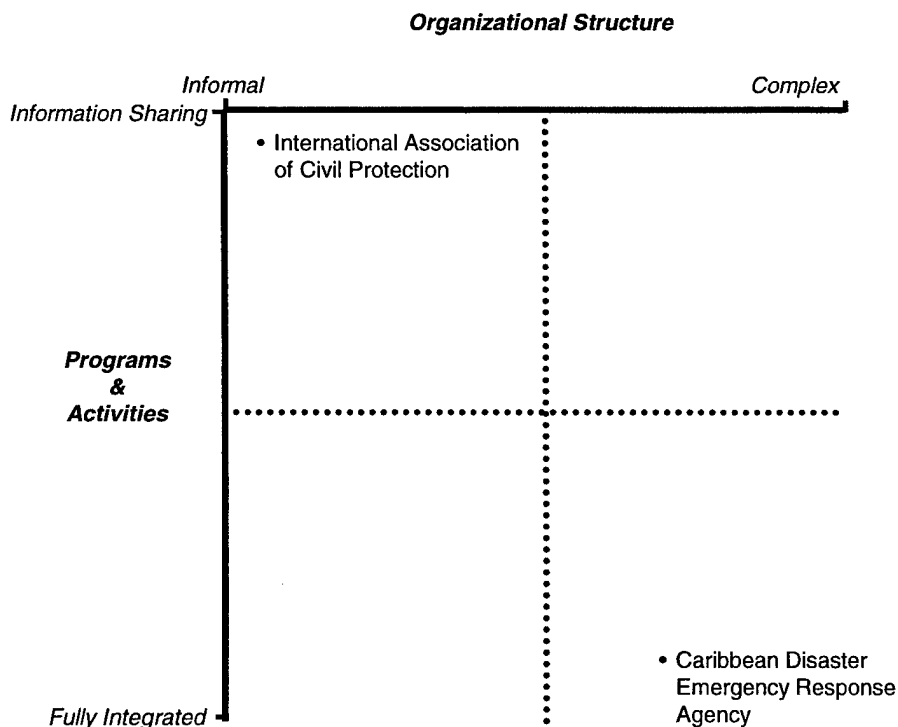

Figure 1. Possible Organizational Structures and Purposes

Each delegation was given the opportunity to demonstrate to the others where on Figure 1, they thought the regional CMEP organization should be. All the delegates placed the regional organization within the ellipse shown in Figure 2, reflecting a shared view of the council's purpose and agreement that the council should be less formal in both its structure and programs. This exercise allowed the delegates to visualize the goals of the council. The facilitators stressed that the delegates must make sure the draft "charter" reflects the desired goals of the group.

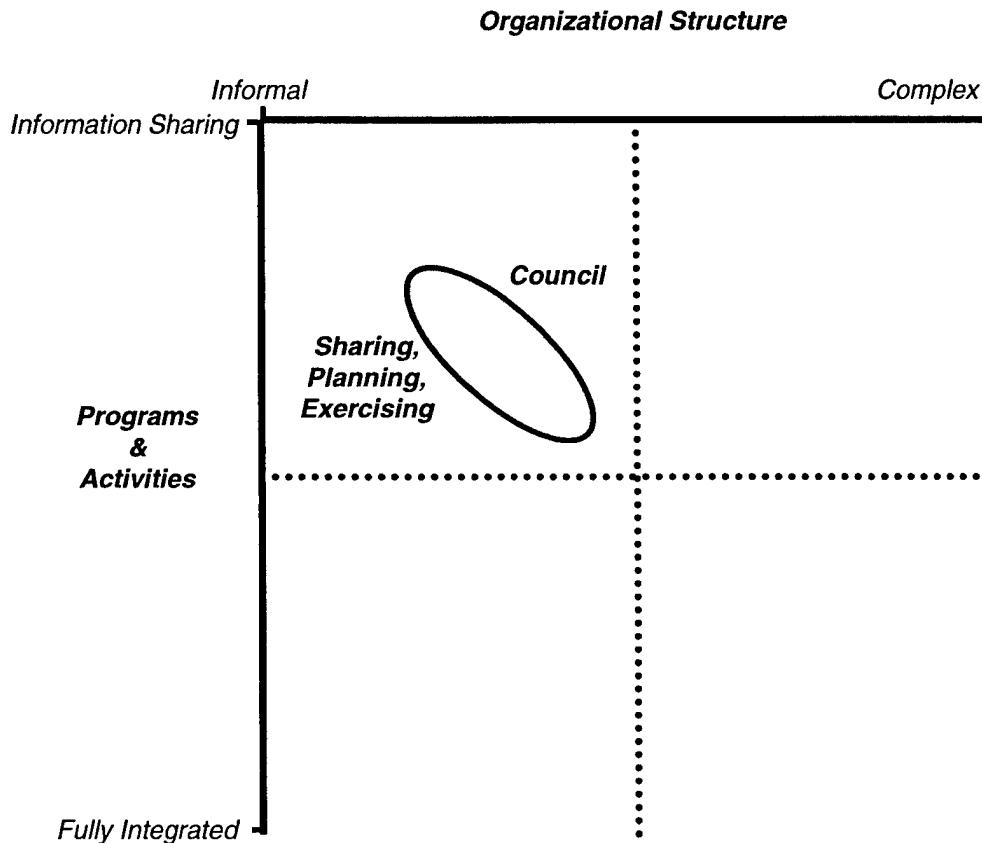

Figure 2. Participants' Consensus of Council's Structural Purpose

The delegates' discussions focused on designating the organization's title as a "Council." The delegates all agreed that "Council" fits within the organizational structure shown in the upper left quadrant of the diagram. The delegates voted that the organizational title should remain "Civil-Military Emergency Planning Council."

The delegates continued sharing their recent experiences with disasters. Delegates from Bulgaria, Romania, and Slovenia gave presentations on how each sent assistance to others during recent disasters. The following topics were discussed:

- How can regional cooperation be improved when sending international disaster assistance?

- Was assistance sent automatically or was it requested? Were things requested sent?
- Did bilateral agreements work? Who was responsible for implementing them?
- What was the experience with sharing and coordinating information with the international community (other nations, UN, and NGOs)? Was information requested of the international community before assistance was sent? Was the affected nation asked for information before assistance was sent? Did necessary information arrive before assistance was sent?
- What was the experience with integrating civilian and military personnel and assets for the national response? Was international assistance integrated into the national, regional or local response of the affected nation?
- What were the strengths and weaknesses in the system for sending international assistance?

The briefers agreed that when there is a large disaster in the region, the political leaders of neighboring countries make the decisions on whether their country will send assistance. The Ministry of Foreign Affairs then considers what aid they might send; they consider military assets, civil protection, and Red Cross resources. The briefers agreed that the biggest problem with sending aid across international boundaries is obtaining access to the affected area. Access can be limited in several ways: lack of transportation assets, uncooperative customs authorities, and weak or nonexistent coordination and communications mechanisms. Finally, the Office of Foreign Disaster Assistance (OFDA), which is part of the United States Agency for International Development (USAID), explained to the delegates its mandate and procedures for sending disaster relief. The delegates were interested in studying these procedures.

4. Policy Sessions Four and Five

With a consensus on the council's purpose, Policy Sessions Four and Five focused on review of the initial draft charter provided by IDA. This draft defined the CMEP Council's necessary operating parameters. The final policy sessions were focused not on the exact content, but rather upon the principles and concepts of the draft Articles. The delegates maintained that each Article needed to be reviewed for consistency of purpose and for legal content.

The initial draft document did not contain a preface or preamble. The delegates drafted one and it was inserted before the draft Articles.⁵

The Articles covered the following principles:

- Council Purpose
- Definitions
- Planning for Emergencies
- Place of Bilateral Arrangements
- Role of the Council
- General Business Matters of the Council
- Coordination
- Funding
- Administrative Issues.

For each article, the delegates presented their suggested changes and then voted on whether the suggested changes reflected the desires of the delegations.⁶

5. Policy Session Six

Policy Session Six produced a Second Draft Document for the proposed Council.⁷ The delegates agreed that there were some issues that could not be resolved in Denver. These unresolved issues included:

- Legality of the working of the draft document
- Council relationships with other regional organizations
- Establishment of internal working groups and procedures to be used by the Council
- Selection and rotation of Chairman and Co-Chairman responsibilities.

The delegates suggested that they be allowed to return to their countries and obtain assistance from their legal advisors and other professionals to develop proposals to resolve this issues.

⁵ See Appendix D.

⁶ The delegates agreed before the initial vote that a simple majority would be sufficient to consider the articles satisfactory.

⁷ See Appendix D.

DG Gheorghe Popescu, Romania's Chief of Civil Protection, invited the delegates to use the June 2000 CMEP Workshop in Bucharest to develop a final agreement. The other delegates agreed that this was good timing and it would provide an excellent forum for discussions.

6. Action Items

The delegates agreed that the national reviews should be completed before 15 May 2000. On or before 15 May, each delegation will provide IDA with their requested changes to the Second Draft. IDA will then review these changes, consolidate and accommodate the changes, highlighting outstanding differences for discussion in June, and provide delegates copies before the June meeting.

The delegates also agreed to develop proposals on the CMEP Council's relationship with other organizations and initiatives in the Southeastern European Region. The delegates called this "the architecture of the council." These proposals will also be submitted to IDA by 15 May for consolidation and presentation in June.

It was agreed that during the CMEP June workshop the national representatives would come with the appropriate delegates to advise and discuss the issues. At the workshop the delegates will prepare a Third Draft Document. Finally, the June conference will allow the delegates to discuss the specifics of the supporting working groups and the standard operating procedures for the council. The goal of the delegates is to have the Council operating by January 2001.

C. CONCLUSIONS

Through facilitated discussions and deliberations, the delegates agreed in principle that the Southeastern European Civil-Military Emergency Planning Council should be formed. They agreed to the purpose of the Council and its general objectives and produced the Second Draft Document, which reflected their views of the Council's authorities and responsibilities. The delegates decided they must have their legal counsels review the document. They also agreed to provide IDA the following items by 15 May 2000:

- Comments and suggested changes to 2nd Draft Document
- Proposed architectural structure of the Council.

The delegates will come to the June workshop in Romania prepared to discuss the Council's work groups and standard operating procedures. Finally, the delegates agreed

that continued Partnership for Peace support for the CMEP initiative is needed to facilitate establishment of the Council.

The delegates accomplished monumental feats during the Denver conference. In addition to completing the Second Draft Document, they presented several briefings about their countries' emergency management systems. There were two briefings that the delegates did not have the opportunity to present:

- Preventive Measures
- Disaster Planning Processes.

They requested that the delegates be allowed to present these briefings at the next workshop. The delegates indicated that these briefings were essential and substantive. These briefings provide further insight into regional capabilities and regional limitations.

In addition to the policy session discussions, the delegates attended a number of briefings from U.S. elected and appointed officials.⁸ They requested that their next meeting allow for more time to reflect on issues raised during the policy sessions and for informal discussions with other delegates. They also thought that it would be beneficial for discussion purposes if each delegation submitted their comments and statements ahead of time. The delegations spent considerable time translating English texts and reading text back. The submission ahead of time would give additional time for review during the policy sessions.

The delegates truly made history in Denver. This was the first time that any group of the Southeastern European countries had purposely gathered to discuss the creation of a regional disaster organization. The delegates want to continue this initiative and maintain the momentum. Therefore, they reminded each other of the internal review requirement for the Second Draft Document. They reminded each other of the types of delegates who must attend the next conference.⁹ Finally, they requested that the U.S. continue to support the CMEP initiatives with funding and personnel in order to ensure the formation of the CMEP Council. A wrap-up briefing recapitulated the results of the conference.¹⁰

⁸ See Appendix E for Schedule of Activities.

⁹ Appendix F lists the attendees of the Denver Conference, many of whom will re-attend in Romania.

¹⁰ See Appendix G.

APPENDIX A

CONFERENCE INTRODUCTION BRIEF

APPENDIX A

CONFERENCE INTRODUCTION BRIEF

Slide 1



***Civil Military Emergency Planning Conference
Denver, Colorado
21-25 February 2000***

MARTIN LIDY
INSTITUTE FOR DEFENSE ANALYSES

32100-1

Slide 2



BACKGROUND

- **US Department of Defense (DoD) has encouraged regional Civil-Military Emergency Planning cooperation within NATO Partner Nations since 1993**
 - Series of Information Technology workshops
 - Joint and combined exercises (NATO or US sponsored)
- **In September, 1999 at the Varna Plenary Session of an information technology workshop, MG Nikolov of Bulgaria proposed forming a Civil Military Emergency Planning Council for the SEDM region.**
- **This conference was developed in order to discuss the proposal and further develop the concept.**

32100-2

Slide 3



CONFERENCE PURPOSE

- **The participant's policy sessions will:**
 - Solicit participants' experiences and lessons identified from recent disasters
 - Provide participants an opportunity to think through strengths and weaknesses
 - Find a common ground in experiences
 - Agree to the need for a regional disaster organization
 - » What will it do
 - » How will it work
 - » What will it accomplish
 - Modify the draft charter based on discussions during sessions
- **This allows the participants to contribute a regional solution to a regional problem**

32100-3

Slide 4



STARTING POINT

- **Southeastern European Defense Ministerial (SEDM) region includes:**
 - NATO Members: GR, IT, TU;
 - Partners: AL, BU, MK, RO, SL
- **Representatives**
 - Have had limited personal contact
 - No common language
- **Region**
 - Rich, complicated history
 - Recently experienced natural disasters (especially earthquakes) and manmade disasters
 - Share desire to better manage future disasters

32100-4

Slide 5



AGENDA THEMES

- **Major Themes geared to prevention, mitigation, response, and recovery phases of disaster management**
 - #1 – Introduction and Background
 - #2 – Disaster Response: Receiving International Assistance
 - #3 – Disaster Response: Sending International Assistance
 - #4 – Preventive Measures
 - #5 – Disaster Planning
 - #6 – Draft Conference Results

3/21/00-5

Slide 6



APPROACH

- **The agenda is subject to participants suggested revisions during the sessions**
- **Role of facilitators**
 - Every session will have two facilitators
 - Provide short introduction each session's major theme
 - Ensure national presentations stay close to agreed schedule
 - Facilitate discussions, encourage questions and debate
 - Summarize key points at end of each session
- **Role of recorders**
 - Record comments
 - Provide summaries at end of each session to facilitators
- **Questions & Answers**

3/21/00-6

APPENDIX B

BULGARIAN CONCEPT BRIEF

APPENDIX B BULGARIAN CONCEPT BRIEF

Slide 1

**WHAT HAS BULGARIA
PROPOSED FOR THE REGION**

MG NIKOLA NIKOLOV
Head of Civil Protection of the
Republic of Bulgaria



Slide 2

CONCEPT

To establish a Civil-Military Emergency
Planning Council for Disaster Response
with the participation of the countries
from the region - Turkey, Greece,
Romania, FYROM, Slovenia, Albania,
Bulgaria and Italy



Slide 3

PURPOSE

The Purpose of the Council is to ensure a continuous exchange of important information and to support the development of cooperation processes between the mentioned countries in the field of Civil-Military Emergency Planning.

Slide 4

In order to reach this objective it is necessary to establish a standing regional system for exchange of information and...

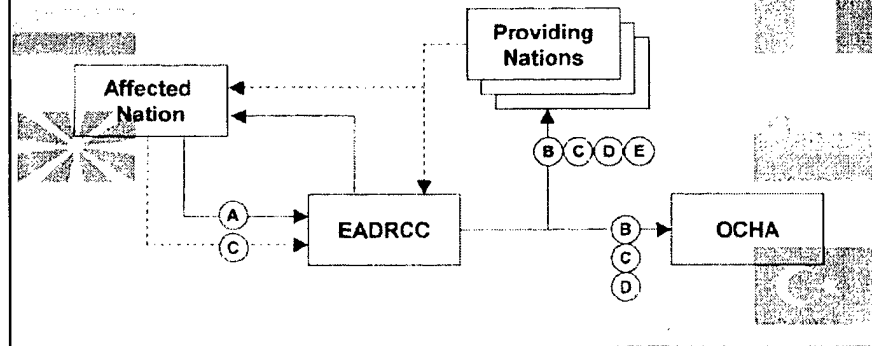

Slide 5

...mutual assistance in natural disasters,
emergencies and catastrophes

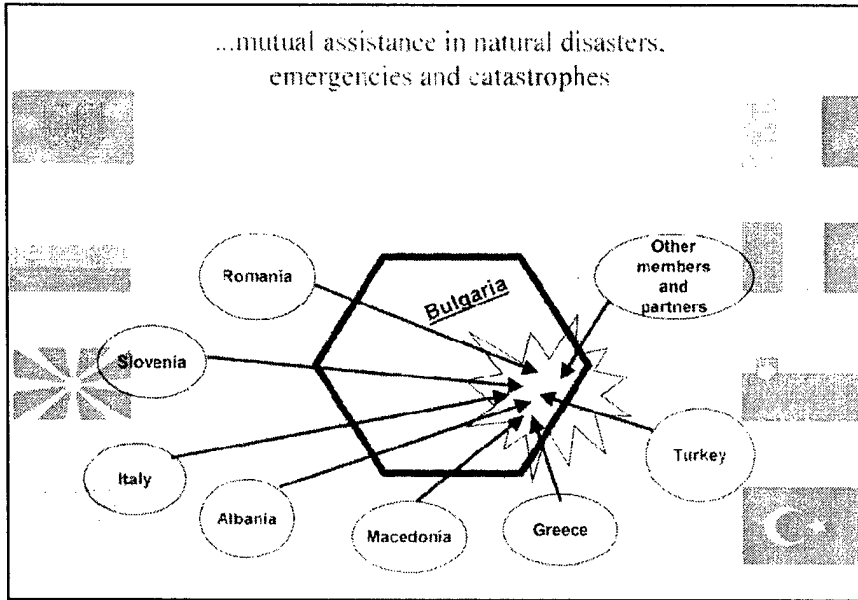

Slide 6

STRUCTURE OF THE
COUNCIL.

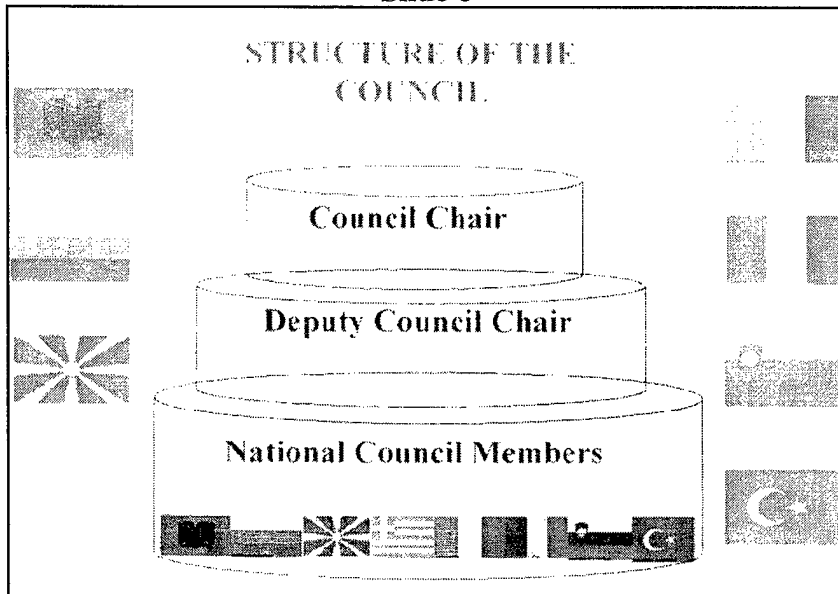

Slide 7

MECHANICS of the Council

- Rotating Chair
- Establishes Policy and Council Priorities
- Tackles Political Issues
- Promotes BI-lateral Agreements supporting CMEP
- Establishes a framework for the working groups

Slide 8

MECHANICS continued

- Members of the Council - eight national Heads of Civil Protection and one representative from National Armed Forces of each nation
- Secretariat
- Working Groups to explore and develop cooperative plans and processes:
 - Information Technology Architecture
 - Standards and procedures
 - Information management

Slide 9

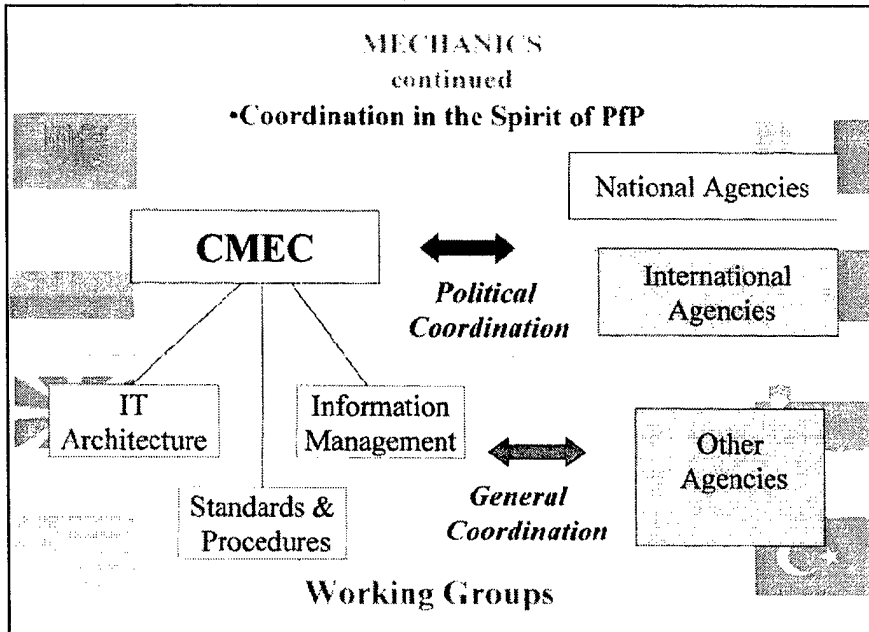

Slide 10

- MECHANICS**
continued
- Joint activities:**
- Development of annual programs
 - Determination and joint implementation of an accessible database
 - Development of security measures for the system
 - Use of PIMS communication capabilities
 - Preparation and implementation of joint programs, plans and exercises of EAPC

Slide 11

MECHANICS continued

•Funding

Each country will fund its national expenses for full participation in the Council

•Reporting work results:

- Working groups report to the Council Meeting
- The Council reports to SEDM Meeting

Slide 12

The Council is open to expand its membership with other countries from Central and Eastern Europe

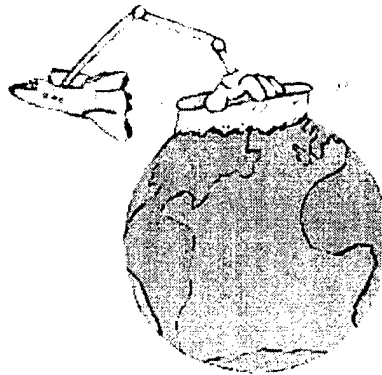

Slide 13

MECHANICS
continued

•Council Meetings

- Council meetings - at least annually
- Locations of meetings rotate
- Meetings through PIMS
- Annual Workshop of the Council

APPENDIX C

REGIONAL DISASTER ORGANIZATIONS BRIEF

APPENDIX C

REGIONAL DISASTER ORGANIZATIONS BRIEF

Slide 1



REGIONAL DISASTER ORGANIZATIONS

MICHELE CECIL
INSTITUTE FOR DEFENSE ANALYSES

3/21/00-1

Slide 2



BACKGROUND

- Countries in the SEDM region have suffered from large scale disasters and are likely to suffer from them again
- Cooperation in civilian and military emergency planning can improve the region's response capabilities and reduce the consequences of these disasters

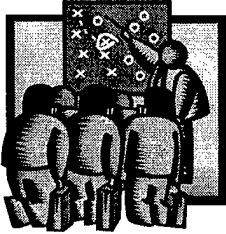

3/21/00-2

Slide 3

 **PURPOSE OF BRIEFING**

- **Discuss survey of regional disaster organizations**
- **The survey reveals that regional disaster organizations have:**
 - Multiple purposes
 - Different organizational structures
- **How can the models of other regional organizations be applied to the SEDM area?**

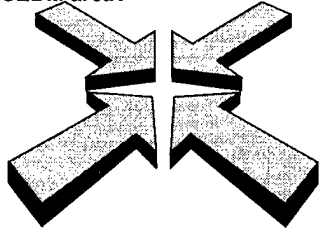

3/21/00-3

Slide 4

 **MULTIPLE PURPOSES**

- **Regional disaster organizations will focus on one or more phases of the disaster management cycle:**
 - Mitigation
 - Preparedness
 - Response
 - Recovery

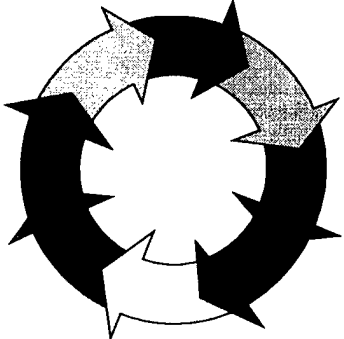

3/21/00-4

Slide 5



MITIGATION

- **If the regional disaster organization's focus is disaster mitigation, the organization can:**
- Complete Hazard and Vulnerability Assessments
- Encourage use of mitigation techniques during reconstruction
- Develop and share:
 - Hazard-resistant Construction codes and methods
 - Public education programs
 - Threat analyses updates

3/21/00-5

Slide 6



PREPAREDNESS

- **If the regional disaster organization's focus is disaster preparedness, the organization can work on regional plans and warning systems**
- **Examples include:**
 - Plans
 - » Develop resource inventories
 - » Conduct regional disaster exercises
 - » Develop mutual aid agreements
 - » Develop evacuation plans and train with the plans
 - Warning
 - » Develop early warning systems for region
 - » Develop emergency communications systems

3/21/00-6

Slide 7



DISASTER RESPONSE

- **If the regional disaster organization's focus is disaster response, the organization can designate one or more response capabilities and develop doctrine.**
- **Examples include:**
 - Information technology or telecommunications
 - Search and rescue
 - Fire or hurricane response
 - Geographic information

3/21/00-7

Slide 8



DISASTER RESPONSE

- **If the regional disaster organization's focus is disaster response, some organizations will combine limited resources and focus on combined operations**
- **Examples include:**
 - Form a regional response unit
 - » Fire brigades
 - » Search and rescue units
 - Establish a regional emergency operations center
 - Institute regional standard operating procedures
 - Establish consolidated storage locations for needed items:
 - » Plastic sheeting
 - » Blankets
 - » Water purification units
 - » Food items

3/21/00-8

Slide 9



RECOVERY

- **If the regional disaster organization's focus is disaster recovery, the organization can work toward improving regional programs for victims**
- **Examples include:**
 - Developing better insurance industries
 - Funding for temporary housing and other reconstruction efforts
 - Instituting mental health programs for victims and emergency responders

3/21/00-9

Slide 10



ORGANIZATIONAL STRUCTURES

- **The regional organizations name themselves in different ways**
- **For example:**
 - Organization
 - Association
 - Coalition
 - Alliance
 - Committee
 - Consortium
 - Council
- **Usually, the name selected has little or no relationship with its purpose**

3/21/00-10

Slide 11



DOCUMENTATION

- Any organization must document its purpose
- Bulgaria has proposed that the SEDM form a regional organization, which would document its purpose in a charter
- To begin this conference we should define these terms:
 - Charter: a document defining the principles and organizational rules of a corporate body, association, committee or council
 - Council: an assembly of persons gathered together for administrative, legislative, or advisory purposes

3/21/00-11

Slide 12



CONFERENCE PLAN

- Define the SEDM regional disaster organization's purpose
- Decide the structure the regional disaster organization will take
- Develop a work plan with measurable accomplishments
- Document the purpose, structure, and the work plan

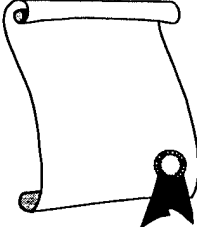

3/21/00-12

Slide 13

CONFERENCE OPTIONS



32100-13

APPENDIX D

SECOND DRAFT CHARTER
OF
SOUTHEASTERN EUROPEAN
CIVIL-MILITARY EMERGENCY PLANNING COUNCIL

APPENDIX D
SECOND DRAFT CHARTER OF
SOUTHEASTERN EUROPEAN
CIVIL-MILITARY EMERGENCY PLANNING COUNCIL

PREAMBLE

The parties to this Memorandum of Agreement, hereinafter, referred to as Member States,

Reaffirming their dedication to the purposes and principles provided by the United Nations Charter,

Cognizant of the fact, civil military cooperation has become very important element for enhancing mutual assistance among nations in the field of disaster relief,

Believing that close cooperation and coordination among the countries of the region of Southeastern Europe must be further developed,

Stressing the importance of Non-Governmental Organizations in the disaster relief and response field,

Supporting NATO's and the Euro-Atlantic Partnership Council's efforts in disaster relief,

The signatories of this Agreement shall establish a Southeastern European Civil Military Emergency Planning Council, hereinafter referred to as the Council.

ARTICLE 1. PURPOSE

In creating this council, the Member States recognize the importance of the prompt, effective utilization of resources essential to the safety, care and welfare of the people in an emergency or disaster.

In addition, the members recognize the importance of plans to be developed among the appropriate Member States, and maintenance of resource inventories for

mutual aid and disaster relief. In order to be successful the plans will have to consider responsibilities and capabilities (both civilian and military) within the Member States and sovereignty issues of the Member States.

Finally the members of the Council recognize the importance of a continual exchange of emergency planning information in order to increase the cumulative capacity of the Member States.

ARTICLE II. DEFINITIONS

For the purpose of the present Agreement, the following definitions shall apply:

“Member States” means signatories of this agreement.

“Civil defense institutions” or “Civil protection institutions” means the national emergency management ministries, which takes preventive measures and action in the event of a disaster.

"Disaster" includes a natural or technological event, which causes or threatens destruction or damage to life or property of such magnitude as to seriously endanger the public health, safety and welfare. Natural or technological disasters include, *inter alia*, earthquakes, volcanic eruptions, landslides, floods, droughts, environmental pollution, pest infestations, forest fire, dam failures, epidemics, nuclear power station accidents, chemical and industrial accidents, air-crashes, railway disasters, and ship wrecks, and other disasters specific for this area.

“Disaster relief” means any action taken for saving life, protecting property and returning life as soon as possible to normal activity.

“Other States” means any state not a Member of the Southeastern European Civil-Military Emergency Planning Council.

ARTICLE III. CIVIL-EMERGENCY PLANNING COOPERATION

There shall be annually or as necessary consultation on plans and procedures between the Member States, Other States, International Organizations, and non-governmental organizations and the free exchange of information and plans, including inventories of any personnel, response organizations, materials and equipment available for disaster relief.

ARTICLE IV. NO PRECLUSION OF BILATERAL ARRANGEMENTS

Inasmuch as it is probable that the pattern for mutual aid among two or more Member States may differ from that appropriate among other Member States, nothing contained in this agreement shall preclude any Member States from entering into supplementary agreements with another Member State(s), Other States or International Organizations.

ARTICLE V. ROLE OF THE COUNCIL

The consultation and decision making of the council will be done with civilian and military personnel. The Council will be composed of the heads or their representatives of Civil Protection and representatives of national armed forces (general staff or others).

The Member States shall consult each other as necessary about their methods, practices, and circumstances in order to enhance practical cooperation in disaster management. It is recognized that this consultation will help alleviate the magnitude of damages from disasters.

The Council will encourage coordinated efforts in all phases of the disaster management cycle: mitigation, prevention, planning, response, and reconstruction.

The Council recognizes the importance of the civil protection institutions in each Member State's territory to coordinate procedures and methods for the rendering of aid to each other.

The Council recognizes the importance of assessing possible disaster relief or assistance that may be offered by the Member States to each other. The assessment of possible relief should be completed before any disaster strikes.

ARTICLE VI. COUNCIL

The Council will host an Annual Workshop and Meeting in order to discuss and evaluate opportunities, issues and developments in disaster relief affecting the region.

Formal Council Meetings shall be held annually or more often if the Council decided necessary.

Each annual meeting will be chaired by a Member State and co-chaired by another Member State. The position of the Chairman shall be rotational according to the

order agreed upon and hold office for a time period to be determined later. The Member State that chairs the committee will organize and host the meeting.

The Council may form a Secretariat and Working Groups to explore and develop the cooperative plans and processes. The details of the Working Groups should be spelled out in supplementary agreements.

A majority of States Member States shall constitute a quorum for the transaction of its general business. Each States Party member of the Council will have one vote on Motions brought before the Council. Motions of Members present shall be carried by a unanimous decision.

The Council may adopt Standard Operating Procedures for agreed upon Council activities.

ARTICLE VII. COORDINATION

The Council may invite disaster relief agencies of other states, international organizations and non-governmental organizations to act as a consultative body under this agreement and representatives of such agencies other states or international organizational or non-governmental organizations may attend respective meeting of the council in a non-voting capacity.

All meetings of the Council are to be hosted in the spirit of Partnerships for Peace.

ARTICLE VIII. FUNDING OF THE COUNCIL:

Each nation will fund its national expenses for full participation in the Council. The U.S. Department of Defense, and other possible sources among EAPC Member nations, may be asked to contribute to common-use costs of the Council, on the basis of actual needs for services of a Secretariat and other administrative start-up requirements.

ARTICLE IX. OFFICIAL COPIES

This agreement shall become operative upon its signing by the appropriate Ministers or governing bodies of all Member States.

Duly authenticated copies of this agreement and of such supplementary agreements as may be entered into shall, at the time of their approval, be deposited with each of the Member States and other appropriate agencies of the Other States or International Organizations.

ARTICLE X. LENGTH OF AGREEMENT

This agreement shall continue in force and remain binding on each Member States until the Parliament or the Prime Minister of such Member States takes action to withdraw therefrom. Such action shall not be effective until 30 days after notice thereof has been sent by the Prime Minister of the Party State desiring to withdraw to the Prime Ministers of all other Member States.

This agreement shall be construed to effectuate the purposes stated in Article I hereof. If any provision of this agreement is declared unconstitutional, or the applicability thereof to any person or circumstance is held invalid, the constitutionality of the remainder of this agreement and the applicability thereof to other persons and circumstances shall not be affected thereby.

Signatures of the Council Members

APPENDIX E
SCHEDULE OF ACTIVITIES

APPENDIX E SCHEDULE OF ACTIVITIES

Time:	Fri 18/Sat 19	Sunday 20	Monday 21	Tuesday 22	Wed 23	Thursday 24	Friday 25	Saturday 26	Sun/Mon
0600 hrs	Travel Day's								All flights leave on Sunday.
630	Arrival into	Delegate Only	Delegate Only	Delegate Only	Delegate Only	Business & Legislative Ldrr	Delegate Only	Delegate Only	Delegates will be transported directly from Winter Park to the airport to arrive at 2 Hrs prior to departure.
700	DIA at:	Continental Breakfast in Hotel	Bkft. In Hotel	Bkft. In Hotel	Bkft. In Hotel	Brkfst/ Wellshire Inn	Bkft. In Hotel	Bkft. In Winter Park Hotel	
730			Travel - Capitol	Travel - FEMA	Travel - FEMA		Travel to CO Springs		
800	FRIDAY 18:		#1- Introductions of National	Welcome by Gov. Owens	FEMA briefing by Rick Weiland	# 6-Summary Prepare final presentation & Draft 2			
830			Disaster Systems @Hyatt	Introduction to St. Legislature	#4- Review Articles of Draft 1	COL Nun		Mountain Rescue Demo by Ski Patrol	
900	FYROM	Rest Day	Professor Szyfiowicz	Lunch	Rick Weiland			Snow Cat or Snow Shoe Tour of Mountain	
930	Bulgaria	Transportation will be provided on request for non-hosted cultural events:	Lunch						
1000		1) Denver Zoo							
1030	Sat 19th:	2) Denver Art Museum	#2- Receiving Intl Assistance & Various RDOs @Hyatt						
1100		3) Museum of Natural History	Hank Brown						
1130	Turkey	4) Botanic Gardens and/or Shopping							
1200			Delegate hours d'oeuvers & cocktails-hotel						
1230	Italy		Welcome						
1300			Reception by TAG & Dinner at BG Andy Love's home						
1330			Evening Free Shopping or Downtown						
1400									
1430			Delegate Only Introductions & Reception						
1500									
1530									
1600									
1630									
1700									
1730									
1800									
1830									
1900									
1930									
2000	Greece								
2030	Albania								
2100	Romania								
2130	Slovenia								
2200									
2230									
2300									
2330									
2400									

APPENDIX F

ATTENDEES

APPENDIX F ATTENDEES

A. DELEGATES BY COUNTRY

Delegation	Phone and Fax Number	Email Address
Albania		
Colonel Bashkim Leka, Director, Directorate of Civil Protection Ministry of Defense of Albania	Phone: 00355 42 26601/ ext 649 Fax: 00355 42 32222	lekab@al.pims.org
Colonel Bashkim Shehi, Commander of Civil Protection Unit	Phone: 00355 42 26601/ ext 649 Fax: 00355 42 32222	
Major Viktor Isakum, Head of Operation & Training, Civil Protection Unit	Phone: 00355 42 26601 ext 649 Fax: 00355 42 32222	isakuv@al.pims.org
Bulgaria		
Major General Nikola S. Nikolov Director Civil Protection Department., Ministry of Defense of Bulgaria	Phone: (359-2)-962-5169 Fax: (359-2) -688-115	civpro@mb.bia-bg.com
Colonel Valeri H. Hristov Head, Department "Operative Preparedness of the Country and Territorial Defense" Operative Directorate, General Staff, Bulgarian Army	Phone: (359-2)-930-4460	
Ms. Maria A. Ianeva, Translator		
Greece		
Major General Panagiotis Harvalas Crisis Management Director, Hellenic General Staff	Phone: 30-1-65-23-886 Fax: 30-1-65-46-340	harvalap@ppc.pims.org
Commander George S. Therianos Commander Civil Emergency Planning Directorate	Phone: 30-1-65-52-228 Fax: 30-1-65-46-340	aflo@hol.gr

Delegation	Phone and Fax Number	Email Address
Italy (Unable to attend at last minute)		
Lt. Gen. (Res.) Umberto Pellizzola Chief Emergency Directorate, Prime Minister's Office – Department of Civil Defense	Phone: 390-66-82-0279 Fax: 390-66-82-0293	
COL Giambattista Nani Chief International Cooperation Section, Military Center for Civil Defense, Italian Defense General Staff	Fax: 390-64-691-2965	
Macedonia (FRYOM)		
Mr. Gjorgi Hrostovski Undersecretary of Defense for Civil Defense and Informatics	Phone: 389-91-28-2582 Fax: 389-91-11-9572	hristovg@mk.pims.org
Colonel Trajce Jakimoski Chief of Engineers, General Staff	Phone: 389-91-28-2230	
Ms. Tamara Stankovska Protocol Assistant, Ministry of Defense	Phone: 389-91-28-2149 Fax: 389-91-11-9572	tamaras@morm.gov.mk; stankovska@hotmail. com
Romania		
Division General Gheorghe Popescu Commander, Civil Protection Command of Romania	Phone 401-232-1777 Fax: 401-311-0265	PROTCIV@ROKNET ro
Lt. Colonel Ville Ramniceanu		ramnicev@ro.pims.org
Lt. Colonel – Eng. Aurelian Ionescu MOD Chief Information Officer, Romanian PIMS Program Manager	Phone: 401-411-2210 Fax: 401 312-0862	
Slovenia		
Mr. Bojan Usenicnik, Director Civil Protection Administration, Ministry of Defense	Phone: (386) 61-171-2280 FAX: (386) 61-131-8117	Milena Dobnick at: Milena.Dobnik@pub. mo-rs.si Romana.Hrovat@pub. mo-rs.si
Brig. Alojz Jehart, Deputy Chief of Staff General Staff, Ministry of Defence	Phone (386) 61 171 1623 Fax: (386) 61 171 1651	

Delegation	Phone and Fax Number	Email Address
Ms. Branka Bozic, Translator		
Turkey		
Mr. Sabahattin Ozelik Head of Department General, Directorate of Civil Defense, Ministry of Interior of Turkey	Phone: 90-312-427-84-10 Fax: 90-312-427-75-43 or -428-43-46	sivsav@atlas.net.tr sivsav@ssgm.gov.tr
Colonel Mehmet Kantarci Chief of Civil-Military Cooperation Section Plans and Policy Division, Turkish General Staff	Fax: 90-312-425-08-13	
Professor Polat Gulkan Chairman of Disaster Management Implementation and Research Center Middle East Technical University	Phone: 90-312-289-62-34 Fax: 90-312-210-77-93	

B. INSTITUTE FOR DEFENSE ANALYSES FACILITATORS

Facilitator	Phone and Fax Number	Email Address
M. Michele Cecil	Phone : (703) 845-2162 Fax : (703) 845 6977	mcecil@ida.org
A. Martin Lidy	Phone : (703) 845-2411 Fax : (703) 845 6977	mlidy@ida.org
Edward F. Smith	Phone : (703) 845-6938 Fax : (703) 845 6977	esmith@ida.org
Victoria D. Leighton	Phone: (425) 454-3675	leighton@ix.netcom.com

C. FACILITATORS

Facilitator	Phone and Fax Number	Email Address
Hank Brown, President University of Northern Colorado	Phone: (970) 351-2222 Fax : (970) 351-1110	Smoser@pres.unco.edu
Gale Norton, Attorney Brownstein, Hyatt & Farber, P.C.	Phone: (303) 471-4061 Cell (303) 507-4087	Gnorton@bhfs.com

Facilitator	Phone and Fax Number	Email Address
COL Rafael Nun Plans Operations & Military Support Officer Colorado National Guard	Phone: (303) 397-3249	nunr@co- arng.ngb.army.mil
Joseph S. Szylowicz, Professor University of Denver		Jszylow@du.edu
Brian Vogt, President South Metro Denver Chamber of Commerce	Phone: (303) 795-0142	Bvogt@bestchamber. com
Richard Weiland, Director, FEMA Region VIII	Phone: (303) 235-4812 Fax: (303) 235-4976	Rick.weiland@fema. gov

D. COLORADO NATIONAL GUARD ORGANIZERS

Organizer	Phone and Fax Number	Email Address
CPT John A. Brackney Inaugural Meeting Project Officer	Phone: (303) 795-4630 Fax (303) 738-7894	JohnBrackney@co.arapahoe. co.us
MAJ Bruce Norquist Inaugural Meeting Executive Officer	Phone: (303) 740-5613 Fax (303) 779-4025	norquist@informix.com

APPENDIX G
WRAP-UP BRIEFING

APPENDIX G WRAP-UP BRIEFING

Introduction

Major General Panagiotis Harvalas, Crisis Management Director, Hellenic General Staff, was selected by the delegates to present the accomplishments of the policy sessions to the USG representatives. He outlined the specific purposes of the briefing for the entire group.

Slide 1



Slide 2



Purpose

- **Present the results of the 6 policy sessions**
- **Discuss what actions need to be accomplished**
- **Discuss the milestones**
- **Lessons learned for next conference**
- **Recommendations**

3/21/00-2

Slide 3



Policy Sessions 1 and 2 Generally Agreed

- **Outstanding beginning for a regional cooperative effort**
- **Overwhelming desire for continued cooperation and consultation**
- **Need for the creation of a venue to share experiences both positive and negative in hopes that future disasters can be better managed**
- **Demonstrated willingness to provide relief and assistance to disaster stricken areas within the region**
- **Ability to provide assistance is often limited by bureaucratic processes**

3/21/00-3

Slide 4

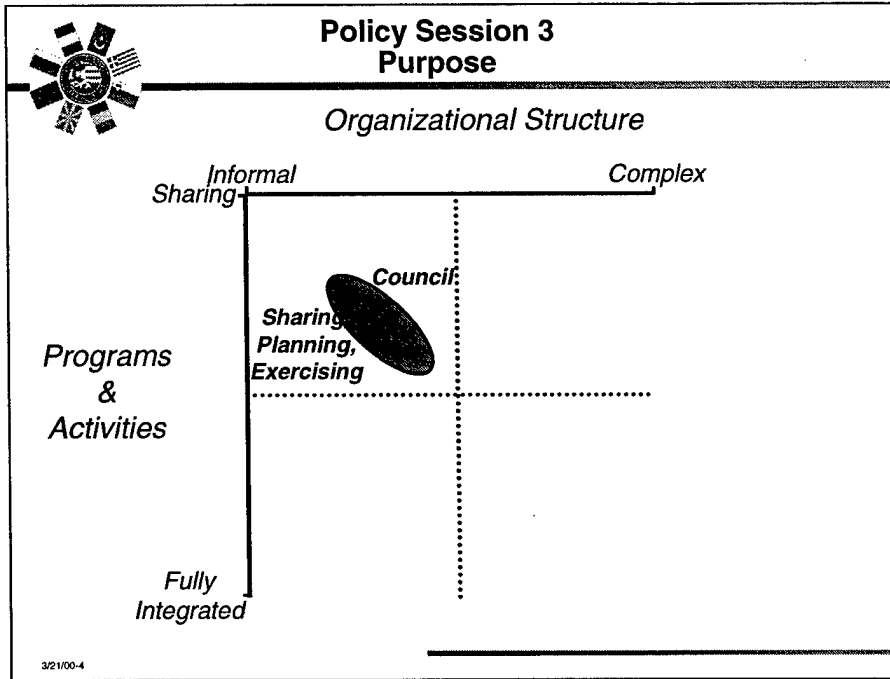

Slide 5

-
- Policy Sessions 4,5, and 6
Desires to Words**
- **All delegations agreed in principle on the 2nd draft of the document forming a Civil Military Emergency Planning Council**
 - Created preamble
 - Consists of 10 Articles
 - **Purpose of the council is to cooperate and consult with each other and as a council on the four phases of the disaster management cycle**
 - Mitigation, Preparedness, Response, and Recovery
 - **Council general business: annual meeting and workshop hosted by the country chairing the council**
- 321/00-5

Slide 6



Actions to be Accomplish

- **Each delegation has been provided with a complete agreed upon - in principle - 2nd draft for their review**
 - by legal authorities
 - by appropriate ministries, organizations and bodies
- **Determine architecture of how the Council relates to existing organizations and structures**
- **Determine number and topics of working groups**
- **Determine rotations and length of service for chairman and co-chairman**
- **Develop Council Standing Operating Procedures (SOPs)**

3/21/00-6

Slide 7



Milestones

- **IDA will provide a conference summary by 15 March**
- **Each delegation will provide written comments and suggested changes on the document to IDA by 15 May**
- **Each delegation will develop a draft architecture of how the council relates to existing organizations and structures to IDA by 15 May**
- **IDA will summarize delegations' comments and changes and draft architectures and provide these to delegations prior to the June conference**
- **Goal is to have delegations sign a finalized document by January 2001**

3/21/00-7

Slide 8



Lesson for the Next Conference

- Delegations should update and present their briefings on “Preventive Measures” and “Their Disaster Planning Process” for the June conference
- Policy sessions should be shorter but with sufficient number to accomplish conference objectives
- Blocks of time for smaller discussions and reflection should be added to the agenda
- All delegations need to submit comments for review prior to the June conference

3/21/00-8

Slide 9



Recommendations

- That this historic initiative be continued
- That we all work to accomplish these milestones
- That each delegation comes to the June meeting with the appropriate delegates (defense, civil protection, legal, and or other)
- That PFP mechanisms be used to continue supporting the creation of this council

3/21/00-9

REPORT DOCUMENTATION PAGE

Form Approved
OMB No. 0704-0188

Public reporting burden for this collection of information is estimated to average 1 hour per response, including the time for reviewing instructions, searching existing data sources, gathering and maintaining the data needed, and completing and reviewing the collection of information. Send comments regarding this burden estimate or any other aspect of this collection of information, including suggestions for reducing this burden, to Washington Headquarters Services, Directorate for Information Operations and Reports, 1215 Jefferson Davis Highway, Suite 1204, Arlington, VA 22203-4302, and to the Office of Management and Budget, Paperwork Reduction Project (0704-0188), Washington, DC 20503.

1. AGENCY USE ONLY (<i>Leave blank</i>)		2. REPORT DATE May 2000		3. REPORT TYPE AND DATES COVERED Final: Sep 1999 – Mar 2000	
4. TITLE AND SUBTITLE Civil-Military Emergency Planning Council Denver Conference Proceedings			5. FUNDING NUMBERS DASW01-98-C-0067, OUSD(A) BB-9-1759		
6. AUTHOR(s) Ms. Michele Cecil, Mr. A Martin Lidy, Mr. Edward F. Smith, Jr.					
7. PERFORMING ORGANIZATION NAME(S) AND ADDRESS(ES) Institute for Defense Analyses 1801 N. Beauregard St. Alexandria, VA 22311			8. PERFORMING ORGANIZATION REPORT NUMBER IDA Document D-2439		
9. SPONSORING/MONITORING AGENCY NAME(S) AND ADDRESS(ES) Mr. Maxwell Alston DoD Project Officer for International Civil-Military Emergency Planning, Office of the Deputy Undersecretary of the Army for International Affairs, 1777 Kent St., Rosslyn, Virginia 22209			10. SPONSORING/MONITORING AGENCY REPORT NUMBER		
11. SUPPLEMENTARY NOTES					
12a. DISTRIBUTION/AVAILABILITY STATEMENT Approved for public release; distribution unlimited. Directorate for Freedom of Information and Security Review (OASD-PA), 6 July 2000			12b. DISTRIBUTION CODE		
13. ABSTRACT (<i>Maximum 200 words</i>) This document summarizes the conference held in Denver, Colorado to discuss the steps and processes needed for implementing a Civil-Military Emergency Planning Council for the countries of the Southeastern Europe Defense Ministerial (SEDM) region. The delegates agreed on working to establish such a Council. As a first step in that direction, they reviewed and modified an initial draft Charter document prepared by IDA. This Second Draft Charter will be reviewed by appropriate national authorities in the SEDM region countries, and refined in a June 2000 workshop scheduled to be held in Bucharest, with a goal of signing a final Charter document by January 2001.					
14. SUBJECT TERMS Civil-Military Emergency Planning; Southeastern Europe; disaster response				15. NUMBER OF PAGES 72	
				16. PRICE CODE	
17. SECURITY CLASSIFICATION OF REPORT Unclassified	18. SECURITY CLASSIFICATION OF THIS PAGE Unclassified	19. SECURITY CLASSIFICATION OF ABSTRACT Unclassified	20. LIMITATION OF ABSTRACT Unlimited		