

REPORT DOCUMENTATION PAGE

Form Approved
OMB No. 074-0188

Public reporting burden for this collection of information is estimated to average 1 hour per response, including the time for reviewing instructions, searching existing data sources, gathering and maintaining the data needed, and completing and reviewing this collection of information. Send comments regarding this burden estimate or any other aspect of this collection of information, including suggestions for reducing this burden to Washington Headquarters Services, Directorate for Information Operations and Reports, 1215 Jefferson Davis Highway, Suite 1204, Arlington, VA 22202-4302, and to the Office of Management and Budget, Paperwork Reduction Project (0704-0188), Washington, DC 20503

1. AGENCY USE ONLY (Leave blank)	2. REPORT DATE 1999	3. REPORT TYPE AND DATES COVERED Proceedings	
4. TITLE AND SUBTITLE Diode Laser-Based Sensor for Fast Measurement of Binary Gas Mixtures		5. FUNDING NUMBERS N/A	
6. AUTHOR(S) Kevin L. McNesby, R. Reed Skaggs, Jeffrey B. Morris, Brian Kennedy, Andrzej W. Miziolek, W.M. Jackson, and Ian A. McLaren			
7. PERFORMING ORGANIZATION NAME(S) AND ADDRESS(ES) U.S. Army Research Laboratory, Aberdeen Proving Ground, MD 21005-5066 Department of Chemistry, University of California-Davis, Davis CA 95616 McLaren Research, Mountain View, CA 94043		8. PERFORMING ORGANIZATION REPORT NUMBER N/A	
9. SPONSORING / MONITORING AGENCY NAME(S) AND ADDRESS(ES) SERDP 901 North Stuart St. Suite 303 Arlington, VA 22203		10. SPONSORING / MONITORING AGENCY REPORT NUMBER N/A	
11. SUPPLEMENTARY NOTES No copyright is asserted in the United States under Title 17, U.S. code. The U.S. Government has a royalty-free license to exercise all rights under the copyright claimed herein for Government purposes. All other rights are reserved by the copyright owner.			
12a. DISTRIBUTION / AVAILABILITY STATEMENT Approved for public release: distribution is unlimited.			12b. DISTRIBUTION CODE A
13. ABSTRACT (Maximum 200 Words) The development and characterization of a gas sensor to measure binary mixtures of oxygen and the vapor from a series of volatile organic compounds, with a time resolution of 10 milliseconds, is described. The sensor is diode laser-based, all signal processing is performed digitally, and control of the sensor and electronics, data collection, and real time readout is by a laptop computer. The discussion will focus on the methods used for laser selection, phase sensitive detection, data storage, and concentration measurements for species which do not possess well resolved rotational-vibrational spectra.			
14. SUBJECT TERMS SERDP, SERDP Collection, diode laser, gas sensor, fire suppression			15. NUMBER OF PAGES 10
			16. PRICE CODE N/A
17. SECURITY CLASSIFICATION OF REPORT unclass	18. SECURITY CLASSIFICATION OF THIS PAGE unclass	19. SECURITY CLASSIFICATION OF ABSTRACT unclass	20. LIMITATION OF ABSTRACT UL

NSN 7540-01-280-5500

Standard Form 298 (Rev. 2-89)
Prescribed by ANSI Std. Z39-18
298-102

20000720 171

DTIC QUALITY INSPECTED 4

Diode Laser-Based Sensor for Fast Measurement of Binary Gas Mixtures

Kevin L. McNesby, R.Reed Skaggs, Jeffrey B. Morris, Brian Kennedy, Andrzej W. Miziolek, W.M. Jackson^Ω, and Ian A. McLaren^{*}

*U.S. Army Research Laboratory
Aberdeen Proving Ground, MD 21005-5066*

^Ω*Dept. of Chemistry, University of California-Davis, Davis CA 95616*

^{*}*McLaren Research, Mountain View, CA 94043*

Abstract

The development and characterization of a gas sensor to measure binary mixtures of oxygen and the vapor from a series of volatile organic compounds, with a time resolution of 10 milliseconds, is described. The sensor is diode laser-based, all signal processing is performed digitally, and control of the sensor and electronics, data collection, and real time readout is by a laptop computer. The discussion will focus on the methods used for laser selection, phase sensitive detection, data storage, and concentration measurements for species which do not possess well resolved rotational-vibrational spectra.

Introduction

For many automated fire suppression systems onboard military vehicles, the nominal time-to-fire-out, after detection by thermal or light sensors, is 250 milliseconds. Because of this critical requirement, detailed evaluation of new fire suppression systems installed onboard military vehicles requires measurements of fuels, oxidizers, fire suppressants, and combustion products with a time resolution at least as fast as the fire suppression event. For the equipment and testing described here, the period of measurement is 10 milliseconds or faster. Because of the extreme hostility of the testing environment, the laser head and control electronics need to be in a safe environment remote from the test site, and the sensing probe needs to be inexpensive and readily replaceable. Other performance characteristics desired for the system are similar to those for an "ideal" industrial gas monitor [1]. These include the ability to measure correctly without interference from other gases and from airborne particles such as dust and smoke, the ability to automatically compensate for pressure and temperature fluctuations, high wavelength stability for extended times, high reliability, being relatively insensitive to vibration, operation at room temperature, and being composed of components with wide availability.

This paper describes efforts towards the development of a high measurement speed binary gas sensor for simultaneous quantitative measurements of fuel and oxygen concentrations. The method of detection relies upon absorption of radiation near a wavelength of 760 nanometers by oxygen, and absorption of radiation near a wavelength of 1700 nanometers by hydrocarbon based fuels [2]. These spectral regions were selected because of the commercial availability of room temperature lasers and detectors operating in this spectral range and because laser radiation in this spectral range may be easily transported at low loss using inexpensive optical fibers. The sensor development consists of two concurrent parts. Part one consists of development of the method of measurement for gases with and without well resolved ro-vibrational transitions, and the design and construction of the light source and fiber optics necessary for remote measurement. Part two consists of the design and implementation of the instrument control electronics, and the interface to allow instrument control and data acquisition using a laptop computer. These efforts are described in what follows.

Background

Most gas phase concentration measurements using near infrared tunable diode laser absorption spectroscopy use wavelength modulation spectroscopic (WMS) techniques [3,4] or balanced ratiometric detection (BRD) [5,6]. Wavelength modulation spectroscopy (WMS) typically employs distributed feedback (DFB) tunable diode lasers. High sensitivity is achieved by phase sensitive detection at frequencies (KHz to MHz) where noise contributions to signal are minimized. Detection is typically made at twice the measurement frequency, and absorption features have a second derivative lineshape. Measurements are made using a single probe laser beam. Balanced ratiometric detection (BRD) uses a balanced photoreceiver to cancel laser intensity noise. To use this technique, a signal and reference beam are required. These are typically generated by splitting the output beam from a single laser source. It is necessary to balance the DC photocurrent from signal and reference lasers, in the absence of any absorption, prior to making a measurement. The noise cancellation circuit subtracts the common noise in signal and reference beams. Differences in photocurrent level caused by attenuation of the signal beam intensity are reported as signal. This technique has the advantage of reporting the true absorption lineshape, and may be employed with widely tuneable lasers such as external cavity tunable diode lasers, which are not suitable for use with phase sensitive detection at high modulation frequencies.

Both of these techniques give good results for concentration measurements of molecules with narrow, well resolved ro-vibrational absorption lines, such as hydrogen fluoride, water, or carbon monoxide [7]. Large and/or heavy molecules may not possess well resolved ro-vibrational absorption bands because of overlap between fundamental, combination, and overtone vibrations, and because of rotational constants which may be less than typical gas phase linewidths [8]. Figure 1 shows the near-infrared vapor phase absorption spectrum of the hydrocarbon-based turbine fuel JP-8 near a wavelength of 1700 nanometers (measured using a Fourier transform spectrometer), and the calculated absorption spectrum of oxygen near a wavelength of 760 nanometers [2]. For JP-8 vapor, the absorption spectrum near a wavelength of 1700 nanometers is essentially a continuous hump.

Because of the lack of well resolved ro-vibrational transitions in the absorbance spectrum of JP-8 vapor shown in Figure 1, conventional WMS is not a practical method for determination of vapor phase concentration of JP-8 fuel. Also, at this time, external cavity tunable lasers are not currently available near a wavelength of 1700 nanometers.

Phase Sensitive Detection

The proposed method for detection of JP-8 vapor, and all other detection methods based upon phase sensitive detection, takes advantage of the following relations:

$$\int_0^{\pi} m(\sin at)n(\sin bt) dt = 0 \quad a \neq b \quad (1)$$

$$2C \int_0^{\pi} m(\sin at)n(\sin bt) dt = Cmn\pi \quad a=b \quad (2)$$

For the discussion to follow, a and b are laser amplitude modulation frequencies, t is time, m and n are amplitudes, and C represents the number of periods over which the integration is carried out.

If the signal of interest is sinusoidal at frequency a (in equation 1), upon multiplication of this periodic signal by a reference sinusoid at frequency b, the resulting integral will be non-zero only when a=b. If the measurement is made at a frequency at which the Fourier component of the broadband noise in the signal is small, the integral of the product of the signal and the reference will exclude broadband signal noise, and only include the signal noise component at the reference frequency. Furthermore, if the signal amplitude is proportional to the desired quantity

being measured, the result of the integration in (2) yields a value directly proportional to the quantity of interest.

Experimental Design

The proposed method uses two fixed frequency amplitude modulated lasers, each modulated at the same frequency but out of phase by 180 degrees [9]. These two lasers are combined to produce the probe beam. Ideally, the combined output of the two lasers will have an amplitude that is invariant with time (in the absence of absorption of either laser output intensity).

The key to the method is selection of one laser wavelength coincident with a wavelength absorbed by the gas of interest, and selection of the second laser wavelength in a region where no absorption is anticipated. When the mixed, modulated probe beam is passed through a gas which preferentially absorbs the laser radiation from laser one, the signal at the detector is modulated at the laser modulation frequency and, for small absorptions, has an amplitude proportional to the concentration of absorbing gas. Figure 2 shows the calculated signal at the detector for a moderately strong absorbing gas for square wave modulation of the probe laser beam components.

Modulation Design

A time (t) dependent square wave, S(a,n,t) at frequency a with amplitude n may be expressed as a sum of sine waves:

$$S(a,n,t) = 0.636n\sin(at) + 0.212n\sin(3at) + 0.1273n\sin(5at) + \dots \quad (3)$$

The signal at the detector, in the absence of any absorption, from two combined square wave amplitude modulated lasers differing in phase by 180 degrees is:

$$S1(a,n,t)+S2(a,m,t) = (0.636n\sin(at) + 0.212n\sin(3at) + 0.1273n\sin(5at) + \dots) + (0.636m\sin(at+\pi) + 0.212m\sin(3at+\pi) + 0.1273m\sin(5at+\pi) + \dots) \quad (4)$$

Using the relationship $-\sin(ax) = \sin(ax + \pi)$, multiplying by the reference sine wave (frequency locked to the laser modulation) and integrating gives:

$$2C \int_0^\pi (S1(a,n,t) + S2(a,m,t))\sin(at) dt = Cp\pi(.636n-.636m) \quad (5)$$

Here, p is the amplitude of the reference sine wave and C is the number of periods over which the integration is carried out. Equation 5 shows that for a probe beam composed of modulated lasers with equal amplitude, the signal at the detector is zero in the absence of any absorption. When the amplitudes of the modulated lasers differ, then the zero absorption signal must be corrected for offset. When the output radiation of laser two is preferentially absorbed by an analyte gas in the path of the probe beam, equation 5 becomes:

$$2C \int_0^\pi (S1(a,n,t) + S2(a,m,t)) (\exp(-\alpha cl))\sin(at) dt = Cp\pi(.636n-.636m(\exp(-\alpha cl))) , \quad (6)$$

Where α is the absorption coefficient of the analyte gas ($\text{cm}^2/\text{molecule}$), c is analyte gas concentration ($\text{molecules}/\text{cm}^3$), and l is the probe beam path length through the analyte gas (cm). When the product $\alpha cl \ll 1$, $\exp(-\alpha cl)$ may be rewritten as $1-A$, (where A is absorbance = (αcl)) so equation 6 may be rewritten:

$$2C \int_0^\pi (S1(a,n,t) + S2(a,m,t)) (\exp(-\alpha cl))\sin(at) dt = Cp\pi(.636n-.636m + .636mA) \quad (7)$$

For component lasers of equal amplitude, equation 7 becomes:

$$2C_0 \int_0^{\pi} (S1(a,n,t) + S2(a,m,t)) (\exp-\alpha cl) p \sin(bt) dt = .636 C p \pi m A \quad (8)$$

Equation 8 shows that the summation of the amplitudes of the two out of phase lasers is directly proportional to the absorbance, A, and hence to the concentration of the analyte gas. Additionally, the signal is directly proportional to the amplitude of the reference sine wave, to the base amplitude of the detector laser signal, and to the number of periods over which the integration is carried out. Using sine wave modulation of the component lasers instead of square wave modulation changes equation 8 to:

$$2C_0 \int_0^{\pi} (S1(a,n,t) + S2(a,m,t)) (\exp-\alpha cl) p \sin(bt) dt = C p \pi m A \quad (9)$$

Equation 9 may be considered the working equation for using this simple method of analysis. It is interesting to note that changing from square wave to sinusoidal amplitude modulation results in almost a 40% increase in signal intensity.

Experimental Considerations

Table 1 lists spectral parameters for several gas phase molecules.

Molecule	λ (absorption region, micrometers)	Absorption Coefficient (cm^2/mol)
HF	1.33	1.3×10^{-20}
H ₂ O	1.393	2.1×10^{-20}
CO	1.567	2.3×10^{-23}
CH ₄	1.651	8.7×10^{-22}

Table 1: Absorption coefficients for selected atmospheric gases.

For 0.1 torr partial pressure in air of CO gas at room temperature, measured over a 10 cm path (13 ppm per meter), the calculated absorbance, A, is 3.55×10^{-6} . Figure 3 shows the value of the integral in Equation 9 versus Absorbance over a range of Absorbances from 1×10^{-7} to 1×10^{-2} , using a modulation frequency of 1 MHz, averaging over 1000 periods, using a reference amplitude of 10 V, and assuming πm is approximately equal to one. The error introduced by the assumption that $\alpha cl \ll 1$ is seen to become important only at relatively high concentrations of analyte gas.

Instrument Control

In order to accommodate both WMS and BRD detection methods, the laser diodes need to be driven by complex waveforms that switch rapidly between the two modulation methods, suggesting the need for an arbitrary waveform generator. In addition, the complex demodulation requirements of the different detection methods involve a flexibility beyond the scope of traditional analog lock-in amplifiers. These considerations, together with the eventual need for high component integration and the ability to operate under extreme environmental conditions without signal drift, led to the selection of a Digital Signal Processing (DSP) approach to waveform generation and demodulation.

For initial laboratory development of the DSP system, it was decided to use a Pentium-based laptop computer running Windows 95, allowing rapid program development using readily-available programming languages. A custom peripheral unit, the McLaren Research DLM-2A Diode Laser Modulator / DSP Lock-In, was developed to provide the required Digital-to-Analog (for diode laser waveform generation) and Analog-to-Digital (for acquisition of the detected signal) conversions, together with high-speed DSP functionality. The ensemble is controlled from a custom data acquisition and control program (called DLM) running on the laptop computer.

The DLM-2A communicates with the laptop computer via the latter's parallel port, using the Enhanced Parallel Port (EPP) mode for transfer speeds up to 1 MB/sec. A Field Programmable Gate Array (FPGA) in the DLM-2A contains the required EPP interface, the waveform generation circuitry, and data and control logic for the Analog-Digital and Digital-Analog Converters. The required DSP functions – synchronous demodulation and signal averaging – are also implemented in the FPGA. This allows modulation and detection frequencies higher than would be the case if the laptop's CPU were performing all of the signal processing tasks.

Before an experiment, the diode laser waveform generation parameters (i.e. modulation frequencies and amplitudes) are selected via software and sent to the DLM-2A, which then starts generating the repetitive complex waveforms for the laser diodes, with a cycle time of 10ms or less. The detector waveform is digitized, then demodulated and integrated within the FPGA, and streamed across to the laptop where it is analyzed in real time, displayed on a "virtual oscilloscope" screen, and stored on disk as required. The analysis algorithms used are typically a) the peak height of the demodulated 2f component (for WMS modulation), and b) the integrated difference between the two detected laser intensities (for BRD modulation). The eventual goal is to determine a single-quantity result, within 10ms of the introduction of a combustible gas mixture, that can determine whether or not fire-suppression action is needed.

The use of a data acquisition and control system developed specifically for the task at hand, with dedicated (but programmable) hardware to offload signal-processing tasks from the host CPU and optimized assembly-language algorithms for signal analysis, allows a considerably faster response time than would be possible using a commercial package such as LabView. In addition, the highly-integrated DSP approach allows for a smooth transition from the laboratory-based development system to a field-deployable unit, at which point the laptop computer can be replaced by an environmentally-rugged embedded processor.

Experimental Apparatus

Figures 4 and 5 are optical and component diagrams of the binary gas sensor, respectively.

This work is supported by the Next Generation Fire Suppression Technology Program (NGP).

Bibliography

- [1] Linnerud, P. Kaspersen, and T. Jaeger, "Gas monitoring in the process industry using diode laser spectroscopy", *Applied Physics B*, Vol. 67, pp. 297-305, (1998).
- [2] L.S. Rothman, R.R. Gamache, R.H. Tipping, C.P. Rinsland, M.A.H. Smith, D. Chris, V. Benner, M. Devi, J.-M. Flaud, C. Camy-Peyret, A. Perrin, A. Goldman, S.T. Massie, L.R. Brown, R.A. Toth, "The Hitran Molecular Database: Editions of 1991 and 1992", *J. Quant. Spectrosc. Radiat. Transfer*, Vol. 48, p. 469, (1992).
- [3] J. Reid and D. Labrie, "Second-Harmonic Detection with Tunable Diode Lasers - Comparison of Experiment and Theory", *Appl. Physics*, B 26, pp. 203-210, (1981).
- [4] J.A. Silver, *Appl. Opt.*, Vol. 31, p. 707, (1992).
- [5] D.M. Sonnenfroh, W.J. Kessler, J.C. Magill, B.L. Upschulte, M.G. Allen, J.D.W. Barrick, "In-situ sensing of tropospheric water vapor using an airborne near-IR diode laser hygrometer", *Appl. Phys. B*, Vol. 67, pp. 275-282, (1998).
- [6] P.C.D. Hobbs, *Proc. SPIE 1376, Laser Noise*, p. 216, (1991).
- [7] McNesby, K.L., Skaggs, R.R., Miziolek, A.W., Clay, M., Hoke, S.H., and Miser, C.S., "Diode Laser-Based Measurements Of Hydrogen Fluoride Gas During Chemical Suppression Of Fires", *Applied Physics B*, Vol. 67, p443, 1998.
- [8] G. Herzberg, *Infrared and Raman Spectra*, Van Nostrand Reinhold Co., New York, 1945.
- [9] personal communication, Mark Allen, Physical Sciences, Inc.

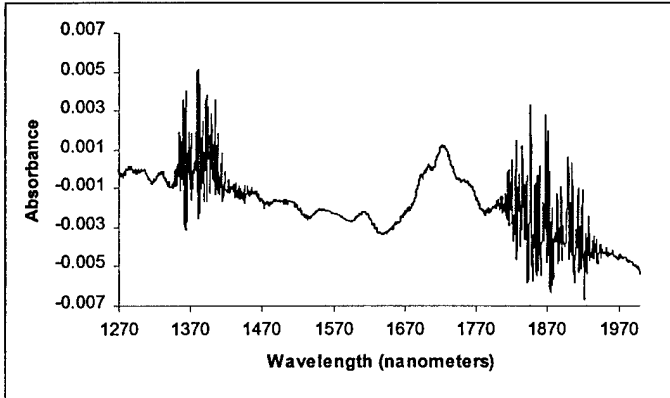

JP-8 vapor, 10 cm path length
355K, 4cm^{-1} resolution,
256 scans.

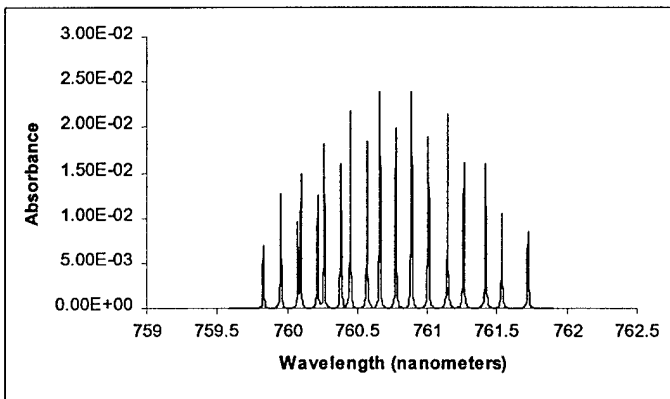

O₂, 1 m path length,
296K, calculated using
HITRAN database.

Figure 1: The measured near-infrared absorbance spectrum in the wavelength region near 1700 nanometers of JP-8 vapor at 355K, and the calculated absorbance spectrum in the wavelength region near 760 nanometers of O₂.

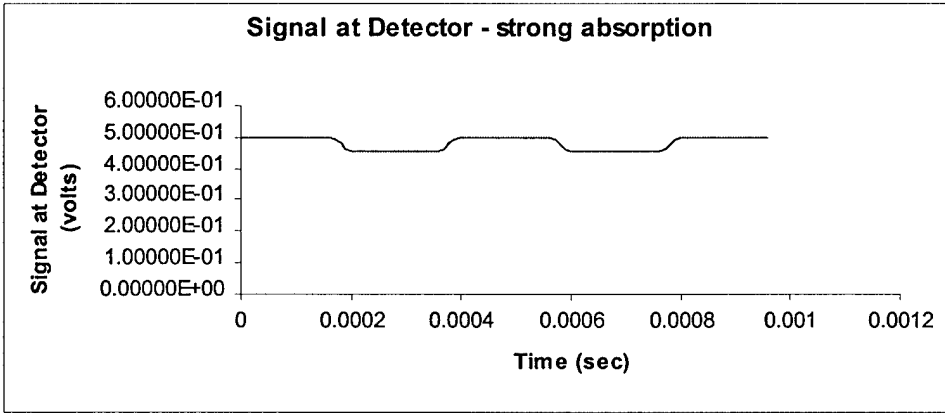
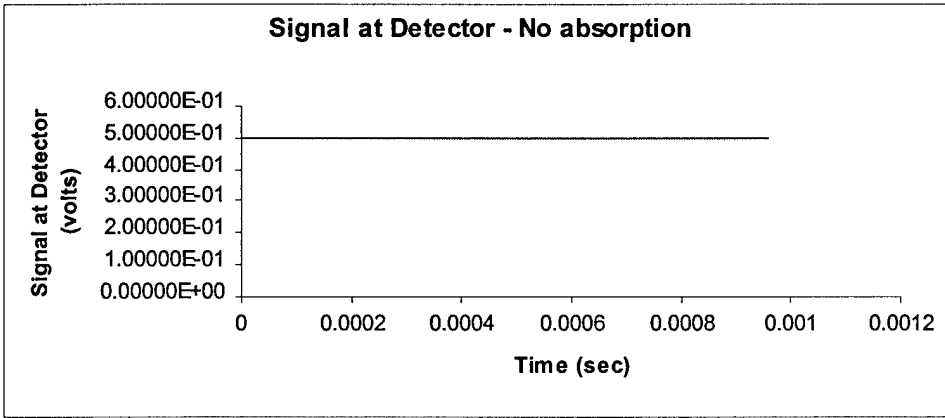

Figure 2: The calculated signal at the detector for a moderately strong absorbing gas for square wave modulation of the probe laser beam components.

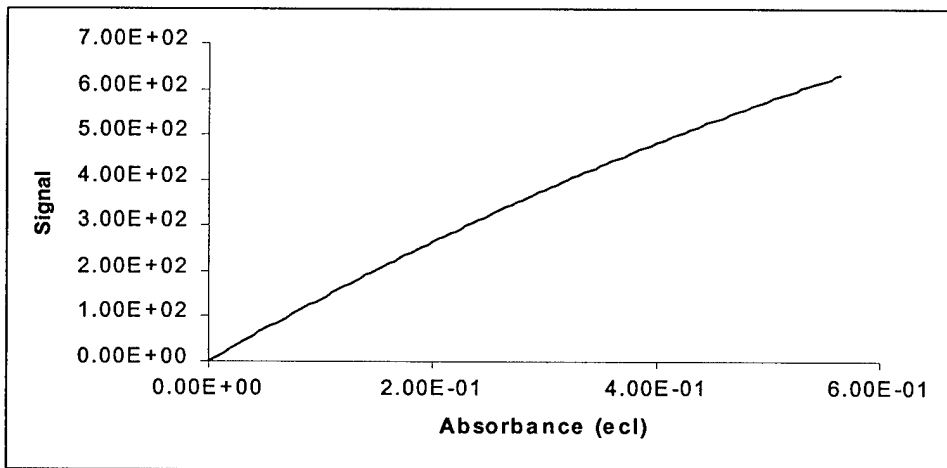
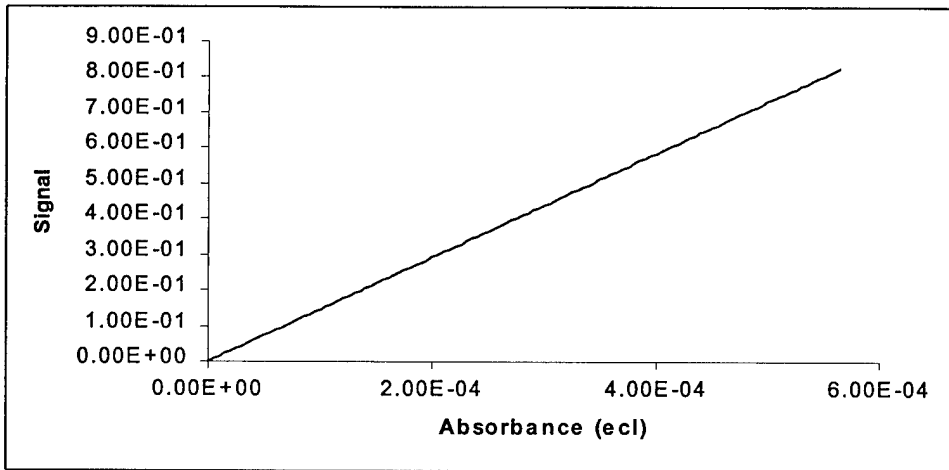

Figure 3: Signal versus Absorbance for concentration measurement of broad band absorbers using amplitude modulation spectroscopy.

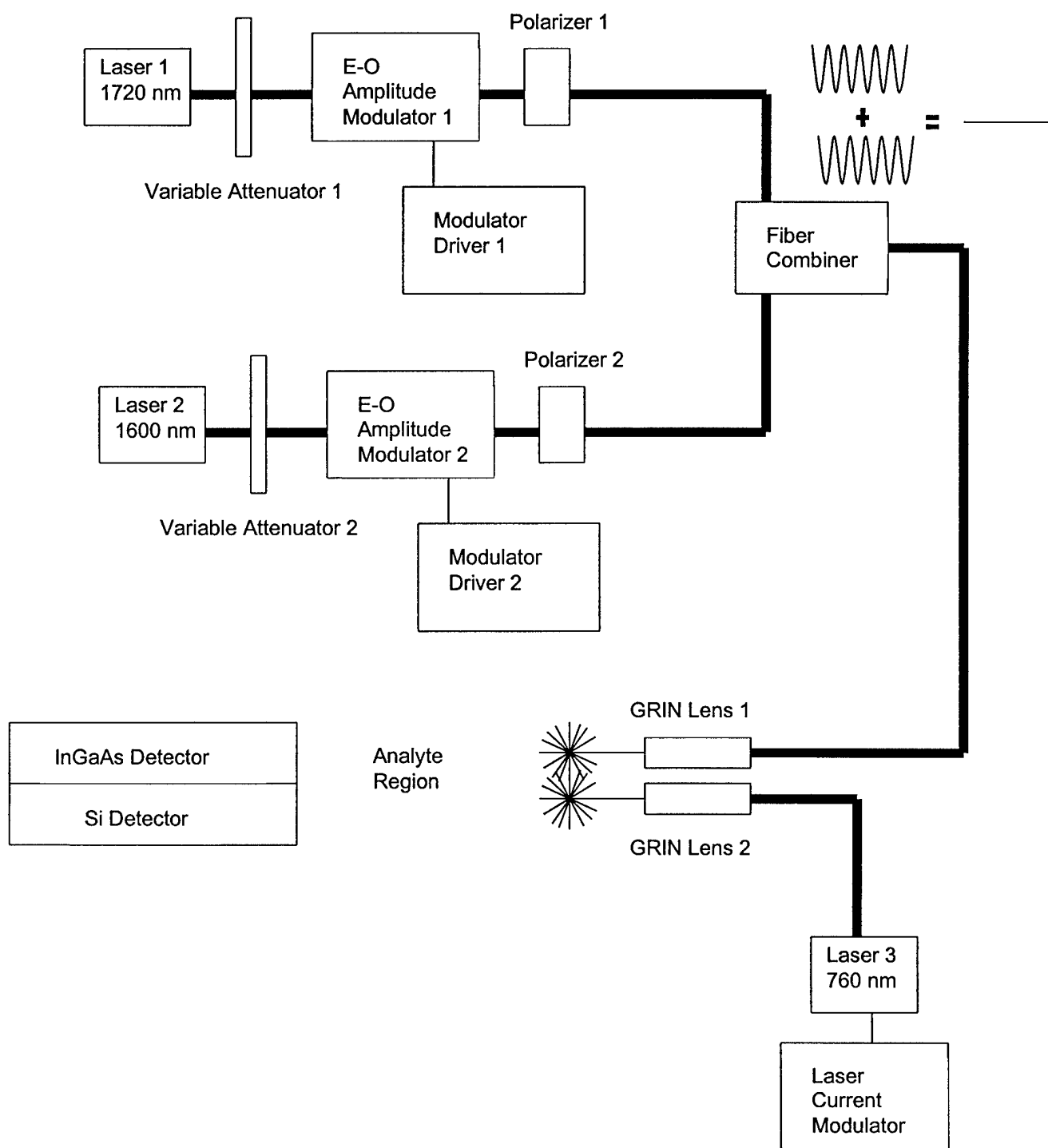

Figure 4: The optical layout of the binary gas sensor.

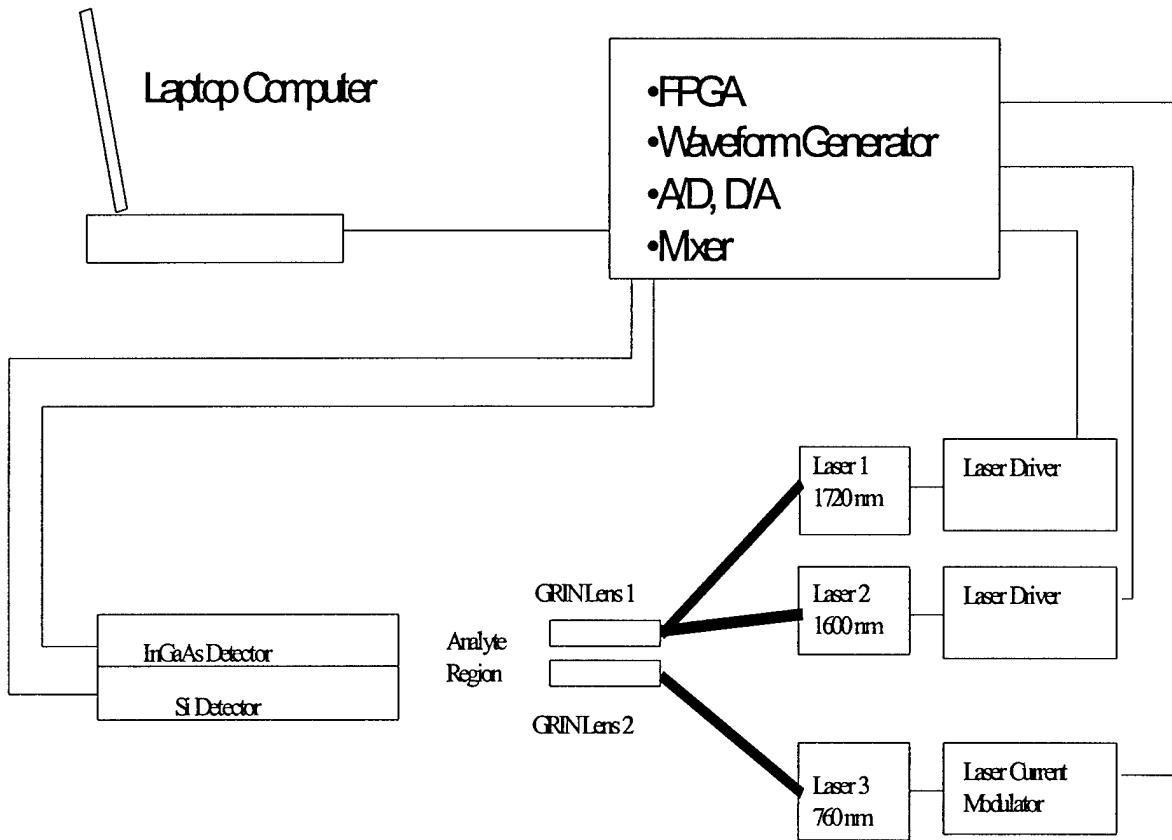

Figure 5: Component diagram of the binary gas sensor.