

74306

**NASA CONTRACTOR  
REPORT**

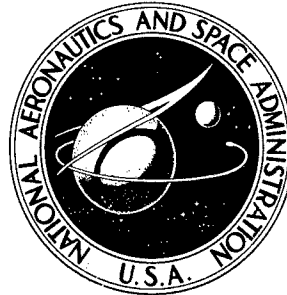

**NASA CR-1322**

**NASA CR-1322**

# **AMPTIAC**

## **A LATTICE MODEL FOR COMPOSITE MATERIALS**

**Reproduced From  
Best Available Copy**

*by T. R. Tauchert, T. Y. Chang, and A. C. Eringen*

*Prepared by*  
**GENERAL TECHNOLOGY CORPORATION**  
Lawrenceville, N. J.  
*for*

**20000711 200**

**NATIONAL AERONAUTICS AND SPACE ADMINISTRATION • WASHINGTON, D. C. • APRIL 1969**

**DTIC QUALITY INSPECTED 4**

A LATTICE MODEL FOR COMPOSITE MATERIALS

By T. R. Tauchert, T. Y. Chang, and A. C. Eringen

Distribution of this report is provided in the interest of information exchange. Responsibility for the contents resides in the author or organization that prepared it.

Issued by Originator as Technical Report No. 8-8

Prepared under Contract No. NASw-1589 by  
GENERAL TECHNOLOGY CORPORATION  
Lawrenceville, N.J.

for

NATIONAL AERONAUTICS AND SPACE ADMINISTRATION

## Abstract

A lattice theory is developed for composite materials in which the matrix and inclusions of the composite are idealized as a gridwork of thermoelastic bars attached to small rigid masses. This model generalizes the spring and mass model prominent in the classical lattice theory of solids. Replacement of the springs by elastic bars provides extra internal degrees of freedom beyond the central force model of the lattice theory. The lattice representation leads to a system of finite difference equations of motion which can be used to solve dynamic and thermal stress problems numerically. Equations for stress and couple stress are obtained, which are identical in form to those of the linear theory of micropolar thermoelasticity.

Jed

## Introduction

Consider a matrix containing inclusions which are of nearly equal size and which are spaced relatively uniformly (spacing  $L$ ), as shown in Figure 1a. Such a composite material can be represented by the lattice model shown in Figure 1b, in which the matrix and inclusions have been replaced by a gridwork of massless, flexible bars attached to small, rigid bodies. The model so introduced represents a generalization of the mass-spring model well known in the theory of crystal lattice. By introducing elastic bars to represent the interparticle forces one provides extra internal degrees of freedom for non-central forces and couples. The model is therefore expected to encompass certain physical phenomena not present in the classical theory. Indeed this turns out to be the case.

In order that the lattice model represents the actual composite material in some optimum sense, "effective" values must be selected for the masses and the mass moments of inertia of the bodies, the stiffness and the thermal expansion coefficients of the bars, etc. For example, the effective mass of each rigid body might be taken as the sum of the mass of a single inclusion and the mass of a volume  $L^3$  of the matrix. Similarly, effective stiffness coefficients for each bar could be found by considering the volume of material between each inclusion and the elastic moduli of the composite (determined, for example, using the classic rule of mixtures). It is not, however, the purpose of this paper to discuss the procedure for selecting the parameters of the lattice model. Rather, the aim here is to develop the equations which govern the deformation of such materials.

## EQUATIONS OF MOTION

A repeating unit of a two-dimensional lattice model is shown in Figure 2. Interactions between nearest and next nearest neighbors are transmitted by means of thermoelastic bars. The bars are capable of supporting axial, shear and bending loads, as well as transmitting heat.

The equations of motion for the rigid body at point  $(\ell, m)$  are

$$\begin{aligned} m \ddot{u}_\alpha^{\ell, m} &= F_\alpha^{\ell, m} \quad (\alpha = 1, 2) \\ J \ddot{\phi}_3^{\ell, m} &= M_3^{\ell, m} \end{aligned} \tag{1}$$

where  $u_\alpha^{\ell, m}$  and  $\phi_3^{\ell, m}$  are the translations and rotation of the lattice point  $(\ell, m)$ , and  $F_\alpha^{\ell, m}$  and  $M_3^{\ell, m}$  refer to the resultant forces and moment exerted on the particle by the adjoining beam elements. The constants  $m$  and  $J$  denote the mass and mass moment of inertia of the body. These forces and moment result from both temperature changes  $\Theta$  in the beams and from relative displacements (translations and rotations) of the end points of the beams. The forces which each element exerts on mass  $m$  may be calculated\* from the stiffness-matrix and the thermal expansion properties of that particular element. It is assumed that all bars connecting nearest lattice points have identical properties, and likewise all bars connecting next-nearest points are identical. Summing the contributions of all eight bars gives the resultant generalized forces  $F_\alpha^{\ell, m}$ ,  $M_3^{\ell, m}$ . Substitution of these expressions into (1) yields

$$\begin{aligned} m \ddot{u}_1^{\ell, m} &= La_1 (u_1^{\ell+1, m} - 2u_1^{\ell, m} + u_1^{\ell-1, m}) \\ &+ Lb_1 (u_1^{\ell, m+1} - 2u_1^{\ell, m} + u_1^{\ell, m-1}) \end{aligned}$$

---

\*The details of computing the forces which a typical bar exerts on the mass are given in the Appendix.

$$+ \frac{L}{2} (a_2 + b_2) (u_1^{\ell+1, m+1} + u_1^{\ell+1, m-1} + u_1^{\ell-1, m+1} + u_1^{\ell-1, m-1} - 4u_1^{\ell, m})$$

$$+ \frac{L}{2} (a_2 - b_2) (u_2^{\ell+1, m+1} - u_2^{\ell+1, m-1} - u_2^{\ell-1, m+1} + u_2^{\ell-1, m-1})$$

$$+ \frac{L^2}{2} b_1 (\phi_3^{\ell, m+1} - \phi_3^{\ell, m-1})$$

$$+ \frac{L^2}{2} b_2 (\phi_3^{\ell+1, m+1} - \phi_3^{\ell+1, m-1} + \phi_3^{\ell-1, m+1} - \phi_3^{\ell-1, m-1})$$

$$- \frac{L^2}{2} g_1 (\theta^{\ell+1, m} - \theta^{\ell-1, m})$$

$$- \frac{L^2}{2} g_2 (\theta^{\ell+1, m+1} + \theta^{\ell+1, m-1} - \theta^{\ell-1, m+1} - \theta^{\ell-1, m-1})$$

$${}_m \ddot{u}_2^{\ell, m} = La_1 (u_2^{\ell, m+1} - 2u_2^{\ell, m} + u_2^{\ell, m-1})$$

$$+ Lb_1 (u_2^{\ell+1, m} - 2u_2^{\ell, m} + u_2^{\ell-1, m})$$

$$+ \frac{L}{2} (a_2 + b_2) (u_2^{\ell+1, m+1} + u_2^{\ell+1, m-1} + u_2^{\ell-1, m+1} + u_2^{\ell-1, m-1} - 4u_2^{\ell, m})$$

$$+ \frac{L}{2} (a_2 - b_2) (u_1^{\ell+1, m+1} - u_1^{\ell+1, m-1} - u_1^{\ell-1, m+1} + u_1^{\ell-1, m-1})$$

$$- \frac{L^2}{2} b_1 (\phi_3^{\ell+1, m} - \phi_3^{\ell-1, m})$$

$$- \frac{L^2}{2} b_2 (\phi_3^{\ell+1, m+1} + \phi_3^{\ell+1, m-1} - \phi_3^{\ell-1, m+1} - \phi_3^{\ell-1, m-1})$$

$$-\frac{L^2}{2} g_1 (\theta^{\ell, m+1} - \theta^{\ell, m-1})$$

$$-\frac{L^2}{2} g_2 (\theta^{\ell+1, m+1} - \theta^{\ell+1, m-1} + \theta^{\ell-1, m+1} - \theta^{\ell-1, m-1})$$

... (2)

$$J_{\phi_3}^{\ddot{\cdot}}{}^{\ell, m} = \frac{L^2}{2} b_1 [(u_2^{\ell+1, m} - u_2^{\ell-1, m}) - (u_1^{\ell, m+1} - u_1^{\ell, m-1})]$$

$$+ \frac{L^2}{2} b_2 [(u_2^{\ell+1, m+1} + u_2^{\ell+1, m-1} - u_2^{\ell-1, m+1} - u_2^{\ell-1, m-1})$$

$$- (u_1^{\ell+1, m+1} - u_1^{\ell+1, m-1} + u_1^{\ell-1, m+1} - u_1^{\ell-1, m-1})]$$

$$- \frac{L}{2} d_1 [\phi_3^{\ell+1, m} + \phi_3^{\ell-1, m} + \phi_3^{\ell, m+1} + \phi_3^{\ell, m-1} + 8\phi_3^{\ell, m}]$$

$$- \frac{L}{2} d_2 [\phi_3^{\ell+1, m+1} + \phi_3^{\ell+1, m-1} + \phi_3^{\ell-1, m+1} + \phi_3^{\ell-1, m-1} + 8\phi_3^{\ell, m}]$$

Here the stiffness coefficients  $a_\xi$ ,  $b_\xi$ ,  $d_\xi$ ,  $g_\xi$  are defined as

$$a_\xi \equiv \frac{E_\xi A_\xi}{L \cdot L_\xi}$$

$$b_\xi \equiv \frac{12E_\xi I_\xi}{L \cdot L_\xi^3}$$

$\xi = 1, 2$  (no summation) (3)

$$d_\xi \equiv \frac{4E_\xi I_\xi}{L \cdot L_\xi}$$

$$g_\xi \equiv \frac{\alpha_\xi E_\xi A_\xi}{L \cdot L_\xi}$$

where  $E_\xi$ ,  $A_\xi$ ,  $I_\xi$ ,  $\alpha_\xi$ , and  $L_\xi$  denote the Young's modulus, cross-sectional area, moment of inertia, coefficient of thermal expansion, and the length of a bar respectively. A subscript  $\xi = 1$  designates bars connecting nearest lattice points;  $\xi = 2$  refers to elements connecting next-nearest points.

The equations of motion (2) can be written as differential equations by first expanding the displacements of neighboring lattice points in Taylor series about the point  $(l,m)$ ; i.e.,

$$u_\alpha^{\ell+1,m} = (1 + L\partial_1 + \frac{L^2}{2!} \partial_1^2 + \dots) u_\alpha^{\ell,m}$$

$$u_\alpha^{\ell-1,m} = (1 - L\partial_1 + \frac{L^2}{2!} \partial_1^2 - \dots) u_\alpha^{\ell,m} \quad (4)$$

$$u_\alpha^{\ell+1,m+1} = (1 + L\partial_1 + L\partial_2 + \frac{L^2}{2!} \partial_1^2 + L^2\partial_1\partial_2 + \frac{L^2}{2!} \partial_2^2 + \dots) u_\alpha^{\ell,m}$$

$$u_\alpha^{\ell+1,m-1} = (1 + L\partial_1 - L\partial_2 + \frac{L^2}{2!} \partial_1^2 - L^2\partial_1\partial_2 + \frac{L^2}{2!} \partial_2^2 + \dots) u_\alpha^{\ell,m}$$

$$u_\alpha^{\ell-1,m-1} = (1 - L\partial_1 - L\partial_2 + \frac{L^2}{2!} \partial_1^2 + L^2\partial_1\partial_2 + \frac{L^2}{2!} \partial_2^2 - \dots) u_\alpha^{\ell,m}$$

where  $\partial_1$  and  $\partial_2$  respectively represent the partial differential operators  $\partial/\partial x_1$  and  $\partial/\partial x_2$ .

Substituting (4) along with similar expansions for the rotations into (2), and retaining only second derivatives, gives

$$\frac{m}{L^3} \ddot{u}_1 = (a_1 + a_2 + b_2) u_{1,11} + (a_2 + b_1 + b_2) u_{1,22}$$

$$+ (2a_2 - 2b_2) u_{2,12} + (b_1 + 2b_2) \phi_{3,2}$$

$$- (g_1 + 2g_2)\theta_{,1} \quad (5)$$

$$\begin{aligned} \frac{m}{L^3} \ddot{u}_2 &= (a_1 + a_2 + b_2) u_{2,22} + (a_2 + b_1 + b_2) u_{2,11} \\ &+ (2a_2 - 2b_2) u_{1,12} - (b_1 + 2b_2) \phi_{3,1} \\ &- (g_1 + 2g_2) \theta_{,2} \end{aligned}$$

$$\begin{aligned} \frac{J}{L^3} \ddot{\phi}_3 &= (b_1 + 2b_2)(u_{2,1} - u_{1,2}) \\ &- \left(\frac{d_1}{2} + d_2\right)(\phi_{3,11} + \phi_{3,22}) - (2b_1 + 4b_2)\phi_3 \end{aligned} \quad \dots(5)$$

Equations (2) and (5) provide a set of difference and differential equations, respectively, which govern the motion of the two-dimensional lattice model under consideration. A solution to these equations which satisfies prescribed boundary conditions yields the displacements  $u_\alpha$  and the rotation  $\phi_3$ . One can then compute the forces and moments in the lattice bars using the appropriate stiffness coefficients (given in the Appendix). Finally, stresses and couple stresses can be found by averaging the forces and moments over the faces of a small cube surrounding a lattice point.

#### STRESSES AND COUPLE STRESSES

To obtain the general constitutive equation for the material represented by this model we isolate the cube surrounding mass  $(l,m)$ , as shown in Fig. 3a. This element is subject to the concentrated forces and moments transmitted by those bars which are intersected by the cube. These generalized forces are expressed in terms of the translations and rotations at the end-points of the beams, as described in the Appendix. Averaging the forces over the faces of the cube, and then making use of

(4) where only first derivatives are retained, gives the stress components (see Fig. 3

$$\begin{aligned}
 t_{11} &= (a_1 + a_2 + b_2) u_{1,1} + (a_2 - b_2) u_{2,2} - (g_1 + 2g_2)\theta \\
 t_{22} &= (a_1 + a_2 + b_2) u_{2,2} + (a_2 - b_2) u_{1,1} - (g_1 + 2g_2)\theta \\
 t_{12} &= (a_2 - b_2) u_{1,2} + (a_2 + b_1 + b_2) u_{2,1} - (b_1 + 2b_2)\phi_3 \\
 t_{21} &= (a_2 - b_2) u_{2,1} + (a_2 + b_1 + b_2) u_{1,2} + (b_1 + 2b_2)\phi_3
 \end{aligned} \tag{6}$$

and the couple-stress components

$$\begin{aligned}
 m_{13} &= \left(\frac{d_1}{4} + \frac{d_2}{2}\right)\phi_{3,1} \\
 m_{23} &= \left(\frac{d_1}{4} + \frac{d_2}{2}\right)\phi_{3,2}
 \end{aligned} \tag{7}$$

It is of interest to compare equations (6) and (7) with the constitutive equations of Eringen's micropolar theory [1,2]. The stresses and couple stresses in a linear micropolar anisotropic thermoelastic solid are given by

$$\begin{aligned}
 t_{kl} &= A_{lkmn} \varepsilon_{mn} + B_{lk}\theta \\
 m_{kl} &= C_{lkmn} \phi_{m,n}
 \end{aligned} \tag{8}$$

where

$$A_{lkmn} = A_{mnlk}, \quad C_{lkmn} = C_{mnlk} \tag{9}$$

and

$$\begin{aligned}\epsilon_{k\ell} &\equiv e_{k\ell} - \epsilon_{k\ell m} (\Gamma_m - \phi_m) \\ e_{k\ell} &\equiv \frac{1}{2} (u_{k,\ell} + u_{\ell,k}) \\ \Gamma_m &\equiv \frac{1}{2} \epsilon_{mnp} u_{p,n}\end{aligned}\tag{10}$$

In equations (8) and (10)  $\phi_m$  is the "microrotation", i.e., the average rotation of "microelements" about the center of mass of a deformed "macrovolume element". For the present model we can interpret the small rigid body at lattice point  $(\ell, m)$  as a microelement, and the surrounding cube as a macrovolume element.

In view of (9) the number of coefficients  $A_{\ell k m n}$  (or  $C_{\ell k m n}$ ) is 45. For an orthotropic material (one having 3 orthogonal planes of symmetry) equations (8) become, in the two-dimensional case

$$\begin{aligned}t_{11} &= A_{1111}\epsilon_{11} + A_{1122}\epsilon_{22} + B_{11}\theta \\ t_{22} &= A_{1122}\epsilon_{11} + A_{2222}\epsilon_{22} + B_{22}\theta \\ t_{12} &= A_{2112}\epsilon_{12} + A_{2121}\epsilon_{21} \\ t_{21} &= A_{1212}\epsilon_{12} + A_{2112}\epsilon_{21}\end{aligned}\tag{11}$$

and

$$\begin{aligned}m_{13} &= C_{3131}\phi_{3,1} \\ m_{23} &= C_{3232}\phi_{3,2}\end{aligned}\tag{12}$$

The lattice model under consideration is symmetric also with respect to the two orthogonal  $45^\circ$  planes which bisect the planes of symmetry  $x_1 - x_3$  and  $x_2 - x_3$

(see Fig. 2). Accounting for this symmetry and using (10), equations (11) reduce to

$$\begin{aligned}
 t_{11} &= A_{1111}u_{1,1} + A_{1122}u_{2,2} + B_{11}\theta \\
 t_{22} &= A_{1122}u_{1,1} + A_{1111}u_{2,2} + B_{11}\theta \\
 t_{12} &= A_{2112}u_{1,2} + A_{1212}u_{2,1} - (A_{1212} - A_{2112})\phi_3 \\
 t_{21} &= A_{1212}u_{1,2} + A_{2112}u_{2,1} + (A_{1212} - A_{2112})\phi_3
 \end{aligned} \tag{13}$$

and equations (12) become

$$\begin{aligned}
 m_{13} &= C_{3131}\phi_{3,1} \\
 m_{23} &= C_{3131}\phi_{3,1}
 \end{aligned} \tag{14}$$

A comparison of (6), (7) with (13), (14) shows that the constitutive equations for the lattice model and the micropolar theory are identical providing

$$\begin{aligned}
 A_{1111} &= a_1 + a_2 + b_2 \\
 A_{1122} &= a_2 - b_2 \\
 A_{2112} &= a_2 - b_2 \\
 A_{1212} &= a_2 + b_1 + b_2 \\
 B_{11} &= -(g_1 + 2g_2) \\
 C_{3131} &= \frac{d_1}{4} + \frac{d_2}{2}
 \end{aligned} \tag{15}$$

Hence, the material constants in the micropolar theory can be evaluated in terms of the stiffness and thermal expansion properties of the lattice elements. Considerable insight into the relative magnitudes of the material constants is thus provided. The approach also suggests a method for investigating how the elastic properties of a micropolar solid would be affected by changes in the geometrical and material properties of the constituents. In effect, it permits the construction of a material with a desired property, within the context of micropolar theory.

The equations of motion for the element of mass (i.e., the cube) are given by the first and second laws of motion of Cauchy which express the local balance of momenta.

Restricted to the two-dimensional case, in the absence of body forces and couples these are

$$t_{\beta\alpha,\beta} = \rho \ddot{u}_{\alpha} \quad (16)$$

and

$$(\alpha, \beta = 1, 2)$$

$$m_{\beta 3, \beta} + \epsilon_{3\beta\gamma} t_{\beta\gamma} = \rho j \ddot{\phi}_3 \quad (17)$$

Substituting (6) into (16) gives equations (5<sub>1,2</sub>) providing

$$\rho \equiv \frac{m}{L^3} \quad (18)$$

Hence the displacement equations of motion for the lattice point (l,m) are identical to those for the cube element.

Substituting (6) and (7) into (18) gives

$$\begin{aligned} \rho j \ddot{\phi}_3 &= (b_1 + 2b_2)(u_{2,1} - u_{1,2}) \\ &+ \left(\frac{d_1}{4} + \frac{d_2}{2}\right)(\phi_{3,11} + \phi_{3,22}) \\ &- (2b_1 + 4b_2)\phi_3 \end{aligned} \quad (19)$$

Letting

$$\rho_j \equiv \frac{J}{L^3} \quad (20)$$

we note that equation (19) then differs from (5<sub>3</sub>) only in the coefficient of the term involving  $(\phi_{3,11} + \phi_{3,22})$ . This difference is due to the fact that the concentrated couples acting on the lattice point  $(\ell, m)$  are different from those acting on the cube element. Note that the cube is intersected by some lattice bars (e.g. bars  $(\ell, m+1 - \ell+1, m)$ ,  $(\ell+1, m - \ell, m-1)$ , etc.) which do not intersect the lattice point. These bars therefore transmit couples to the cube, but not to the lattice point. In addition there are couples acting on the cube which are associated with the transfer of shear forces from the lattice point to the faces of the cube.

#### REFERENCES

1. A. Cemal Eringen, "Linear Theory of Micropolar Elasticity", J. Math. Mech. 15, 909-924, (1966).
2. T. R. Tauchert, W. D. Claus, Jr., T. Ariman, "The Linear Theory of Micropolar Thermoelasticity," Int. J. Engng. Sci., 6, 37-47, (1968).

APPENDIX: INTERACTION FORCES IN THE LATTICE MODEL

The nature of the interaction forces transmitted by a thermoelastic beam in the lattice model is now examined. Each element is assumed to be a straight bar of uniform cross-sectional area  $A$ , flexural rigidity  $EI$ , length  $L$  and coefficient of thermal expansion  $\alpha$ . An element is capable of resisting an axial force, shear and flexure. The location and direction of the generalized forces ( $Q_i$ ) and the corresponding generalized displacements ( $q_i$ ) which act on a typical element are shown in Fig. 4. The forces  $Q_i$  are linearly related to the displacements  $q_i$  and to the average temperature change  $\Delta\theta$  in the beam. The temperature is assumed to be constant over any cross-section, and to vary linearly along the axis of the beam. In this case the forces  $Q_i$  are given by\*

$$\{Q\} = [S] \{q\} + [S_t] \Delta\theta \quad (A.1)$$

where the stiffness matrix  $[S]$  is

$$[S] = \begin{bmatrix} \frac{EA}{L} & 0 & 0 & -\frac{EA}{L} & 0 & 0 \\ 0 & \frac{12EI}{L^3} & \frac{6EI}{L^2} & 0 & -\frac{12EI}{L^3} & \frac{6EI}{L^2} \\ 0 & \frac{6EI}{L^2} & \frac{4EI}{L} & 0 & -\frac{6EI}{L^2} & \frac{2EI}{L} \\ -\frac{EA}{L} & 0 & 0 & \frac{EA}{L} & 0 & 0 \\ 0 & -\frac{12EI}{L^3} & -\frac{6EI}{L^2} & 0 & \frac{12EI}{L^3} & -\frac{6EI}{L^2} \\ 0 & \frac{6EI}{L^2} & \frac{2EI}{L} & 0 & -\frac{6EI}{L^2} & \frac{4EI}{L} \end{bmatrix} \quad (A.2)$$

\*A rectangular matrix is denoted by  $[ ]$ ; a column matrix by  $\{ \}$ .

and the forces resulting from thermal expansion of the bars are determined using

$$[S_T] = \begin{bmatrix} \alpha EA \\ 0 \\ 0 \\ -\alpha EA \\ 0 \\ 0 \end{bmatrix} \quad (A.3)$$

We now consider a particular beam element, for example the one connecting lattice points  $(l, m)$  and  $(l + 1, m + 1)$  as shown in Figure 5.  $P_1$ ,  $P_2$  and  $P_3$  denote the generalized forces which act on mass  $(l, m)$ , and  $P_4$ ,  $P_5$  and  $P_6$  denote those acting on particle  $(l + 1, m + 1)$ . These forces may be expressed in terms of the equal and opposite forces which the particle exerts on the beam

$$\{P\} = [A]\{Q\} \quad (A.4)$$

where from geometry

$$\begin{bmatrix} -\frac{1}{\sqrt{2}} & \frac{1}{\sqrt{2}} & 0 & 0 & 0 & 0 \\ -\frac{1}{\sqrt{2}} & -\frac{1}{\sqrt{2}} & 0 & 0 & 0 & 0 \\ 0 & 0 & -1 & 0 & 0 & 0 \\ 0 & 0 & 0 & -\frac{1}{\sqrt{2}} & \frac{1}{\sqrt{2}} & 0 \\ 0 & 0 & 0 & -\frac{1}{\sqrt{2}} & -\frac{1}{\sqrt{2}} & 0 \\ 0 & 0 & 0 & 0 & 0 & -1 \end{bmatrix} \quad (A.4')$$

The generalized displacements  $q_i$  (assumed infinitesimal) may be expressed in terms of the displacements of the masses ( $\ell, m$ ) and ( $\ell + 1, m + 1$ ) as

$$\{q\} = [B]\{u_1^{\ell, m}, u_2^{\ell, m}, \phi_3^{\ell, m}, u_1^{\ell+1, m+1}, u_2^{\ell+1, m+1}, \phi_3^{\ell+1, m+1}\} \quad (A.5)$$

where

$$[B] = \begin{bmatrix} \frac{1}{\sqrt{2}} & \frac{1}{\sqrt{2}} & 0 & 0 & 0 & 0 \\ -\frac{1}{\sqrt{2}} & \frac{1}{\sqrt{2}} & 0 & 0 & 0 & 0 \\ 0 & 0 & 1 & 0 & 0 & 0 \\ 0 & 0 & 0 & \frac{1}{\sqrt{2}} & \frac{1}{\sqrt{2}} & 0 \\ 0 & 0 & 0 & -\frac{1}{\sqrt{2}} & \frac{1}{\sqrt{2}} & 0 \\ 0 & 0 & 0 & 0 & 0 & 1 \end{bmatrix} \quad (A.5')$$

The average temperature change in the beam is

$$\Delta\theta = [C]\{\theta^{\ell, m}, \theta^{\ell+1, m+1}\} \quad (A.6)$$

where

$$[C] = [1/2 \quad 1/2] \quad (A.6')$$

Substituting (A.2) through (A.6) into (A.1) gives

$$\begin{aligned} \{P\} = & [K]\{u_1^{\ell,m}, u_2^{\ell,m}, \phi_3^{\ell,m}, u_1^{\ell+1,m+1}, u_2^{\ell+1,m+1}, \phi_3^{\ell+1,m+1}\} \\ & + [K_T]\{\theta^{\ell,m}, \theta^{\ell+1,m+1}\} \end{aligned} \quad (\text{A.7})$$

where

$$\begin{aligned} [K] &= [A][S][B] \\ [K_T] &= [A][S_T][C] \end{aligned} \quad (\text{A.7'})$$

In expanded motion, the interaction forces transmitted to mass  $(\ell, m)$  become

$$\begin{aligned} P_1 &= \frac{L}{2} (a_2 + b_2)(u_1^{\ell+1,m+1} - u_1^{\ell,m}) \\ &+ \frac{L}{2} (a_2 - b_2)(u_2^{\ell+1,m+1} - u_2^{\ell,m}) \\ &+ \frac{L^2}{2} b_2 (\phi_3^{\ell+1,m+1} + \phi_3^{\ell,m}) \\ &- \frac{L^2}{2} g_2 (\theta^{\ell+1,m+1} + \theta^{\ell,m}) \\ P_2 &= \frac{L}{2} (a_2 + b_2)(u_2^{\ell+1,m+1} - u_2^{\ell,m}) \\ &+ \frac{L}{2} (a_2 - b_2)(u_1^{\ell+1,m+1} - u_1^{\ell,m}) \\ &- \frac{L^2}{2} b_2 (\phi_3^{\ell+1,m+1} + \phi_3^{\ell,m}) \\ &- \frac{L^2}{2} g_2 (\theta^{\ell+1,m+1} + \theta^{\ell,m}) \end{aligned} \quad (\text{A.8})$$

$$P_3 = \frac{L^2}{2} b_2 [(u_2^{\ell+1,m+1} - u_2^{\ell,m}) - (u_1^{\ell+1,m+1} - u_1^{\ell,m})] \\ - \frac{L}{2} d_2 (\phi_3^{\ell+1,m+1} + 2\phi_3^{\ell,m})$$

where

$$a_2 = \frac{E_2 A_2}{L \cdot L_2}$$

$$b_2 = \frac{12E_2 I_2}{L \cdot L_2^3}$$

$$d_2 = \frac{4E_2 I_2}{L \cdot L_2}$$

$$g_2 = \frac{\alpha_2 E_2 A_2}{L \cdot L_2}$$

(A.9)

The subscripts 2 in (A.8) and (A.9) have been introduced in order to indicate that these quantities refer to a beam element which connects next-nearest lattice points. A subscript 1 is used to designate nearest lattice points.

Expressions for the interaction forces in the other bars are found in a similar manner.

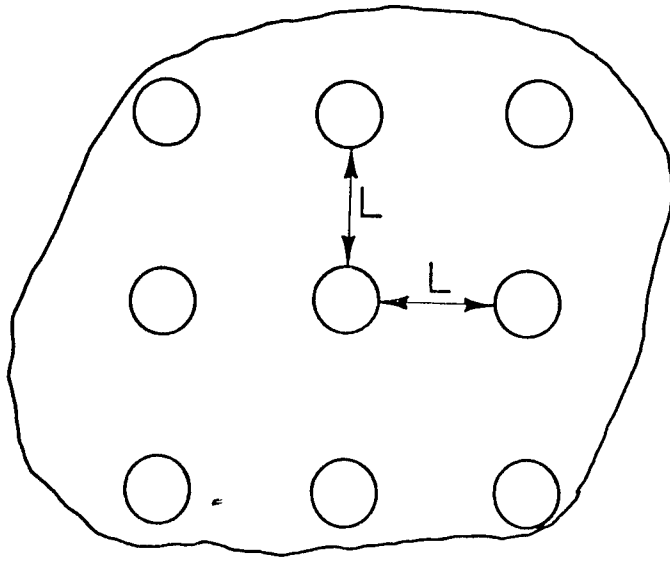

a) Composite Material.

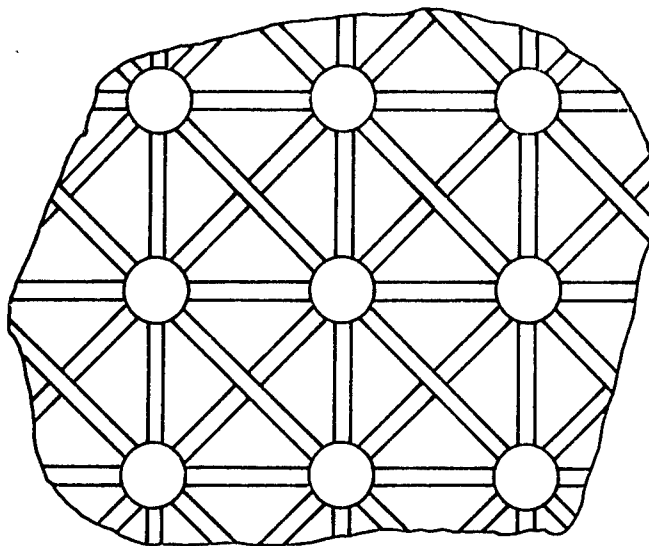

b) Corresponding Lattice Model.

Figure 1.

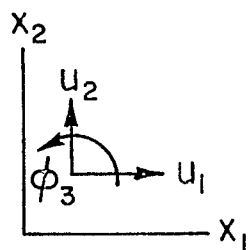
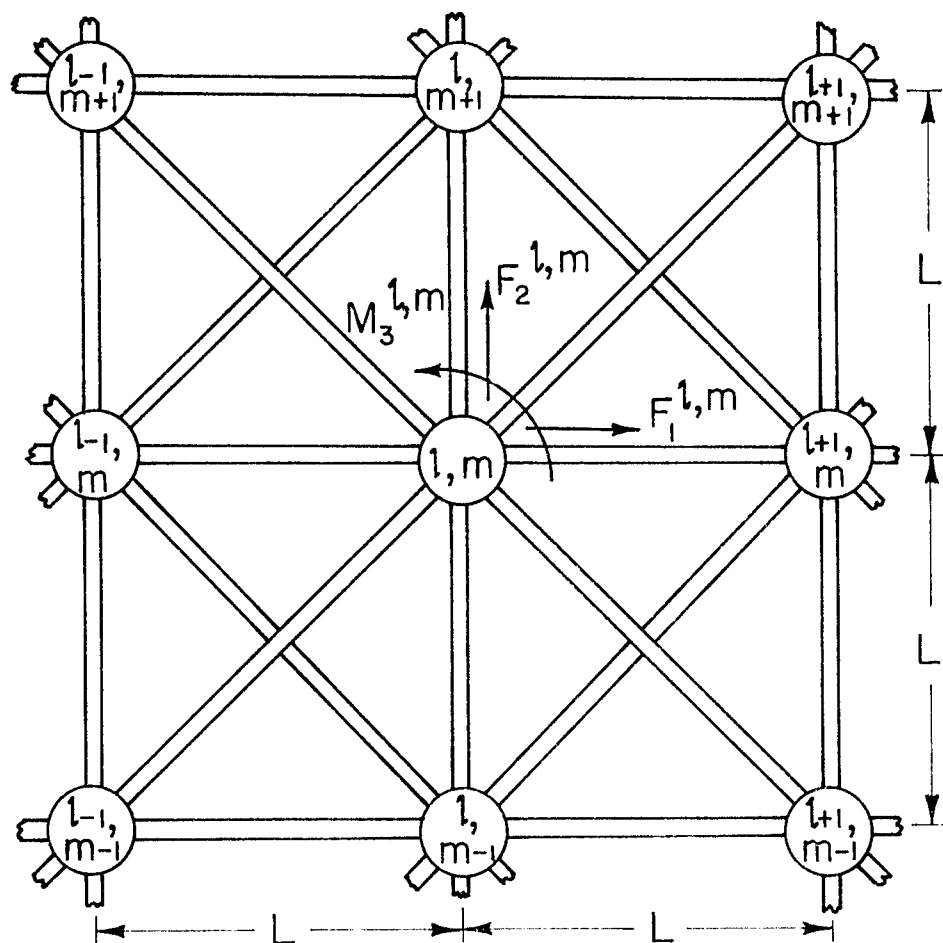
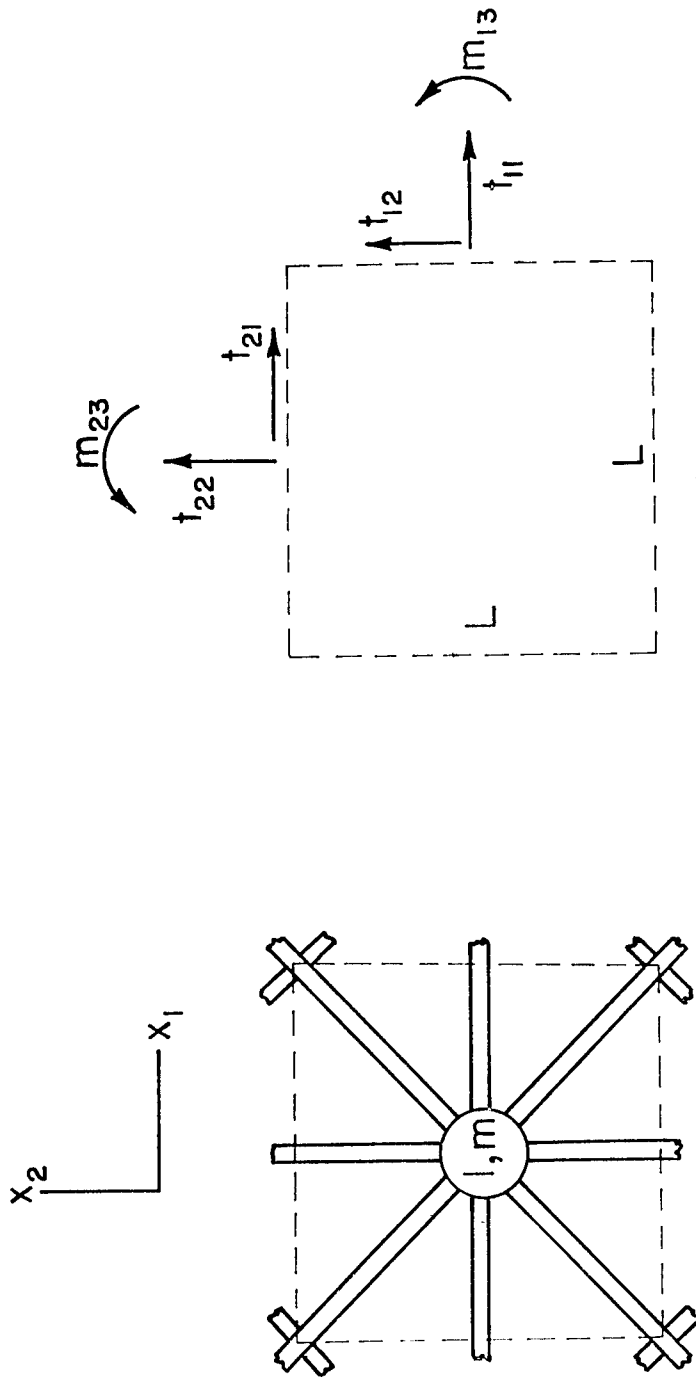

Figure 2. Repeating Unit of a Two-Dimensional Lattice Model.



b) Stresses and Couple Stresses.

a) Cube Surrounding Lattice Point ( $l, m$ ).

Figure 3.

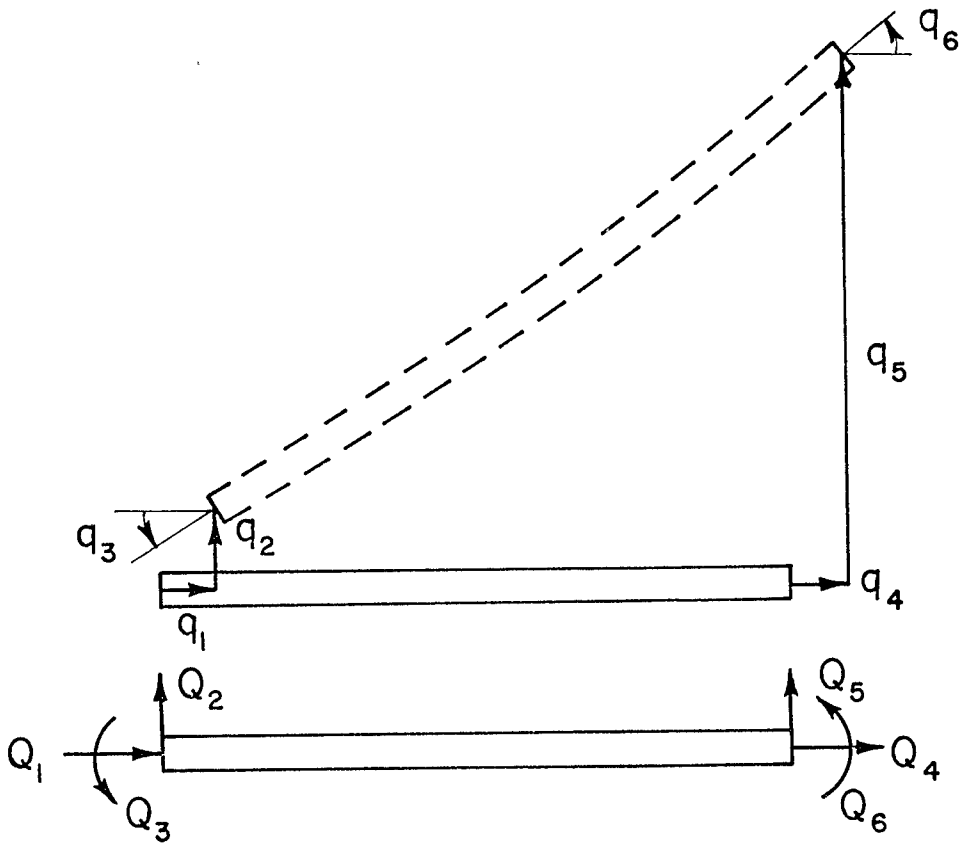

Figure 4. Typical Thermoelastic Beam Element.

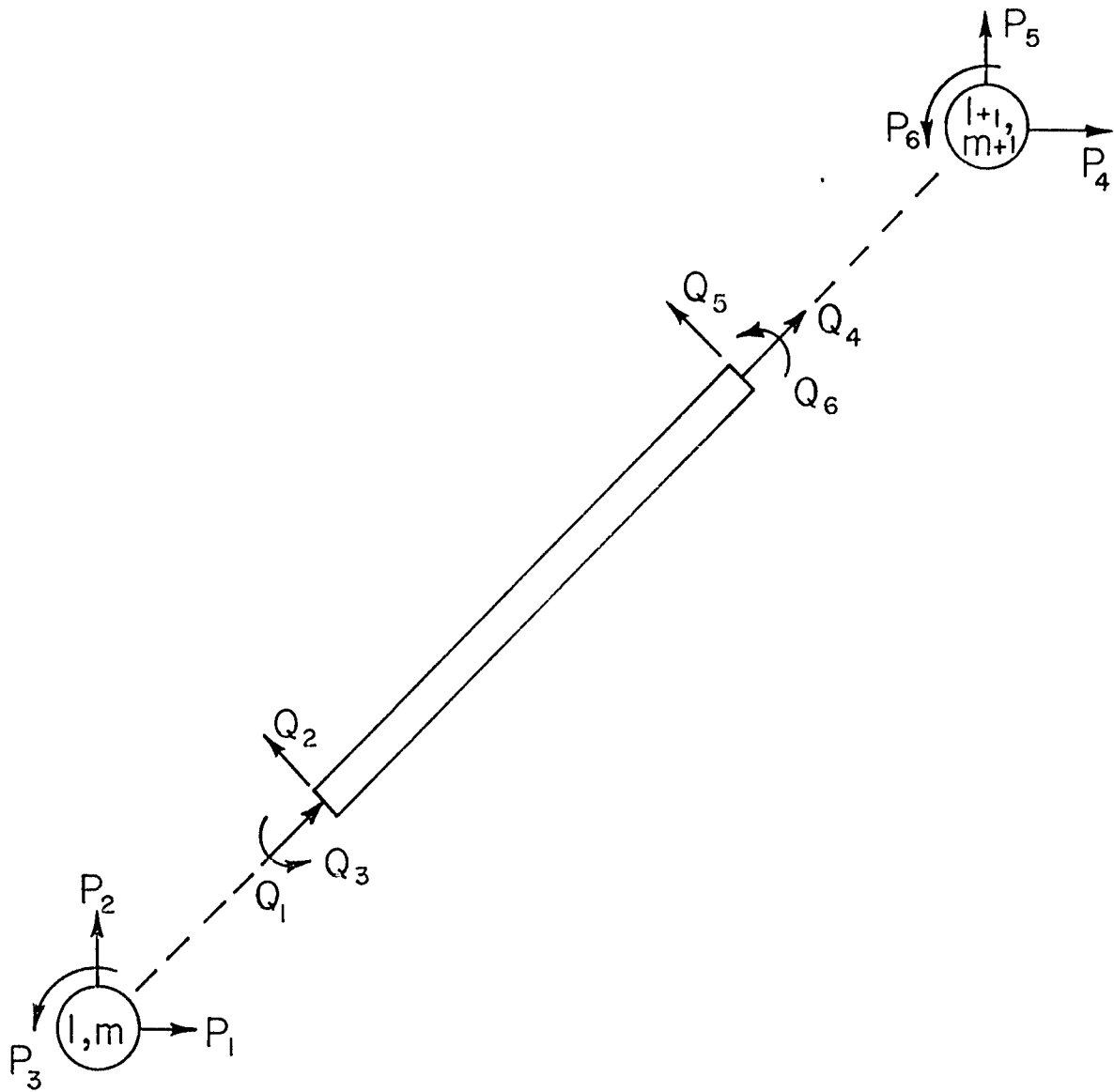

Figure 5. Beam Element Connecting Lattice Points  $(l, m)$  and  $(l+1, m+1)$ .