

AFWAL-TM-85-247-FIMN

THE DESIGN AND TESTING OF
PNEUMATIC SYSTEMS FOR MEASURING
LOW PRESSURES IN HYPERSONIC
WIND TUNNELS

by

Matthew J. Wagner and
Gary A. Dale
Aeromechanics Division
Flight Dynamics Laboratory
Wright-Patterson AFB, Ohio

November 1985

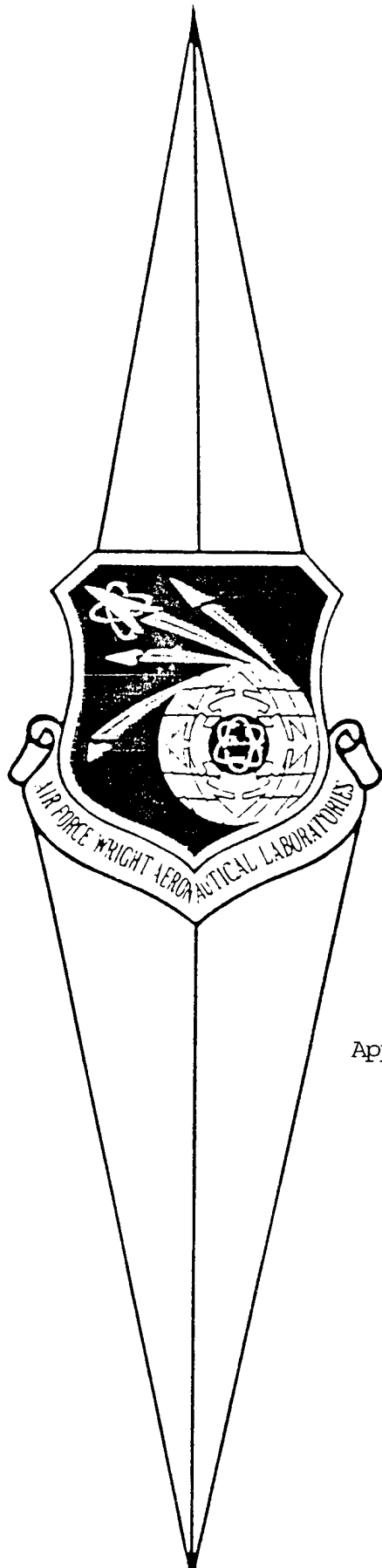

Approved for public release; distribution unlimited.

AERONAUTICAL LABORATORIES
FLIGHT DYNAMICS LABORATORY
AEROMECHANICS DIVISION
EXPERIMENTAL ENGINEERING BRANCH
WRIGHT-PATTERSON AFB, OHIO 45433

20000627 198

BY THE QUALITY INSPECTED 4

FORWARD

This Technical Memorandum was prepared by M. J. Wagner and G. A. Dale of the Aeromechanics Division, Air Force Wright Aeronautical Laboratories, Wright-Patterson Air Force Base, Ohio. The technical developments were performed as an element under Work Unit Number 24041307, "Development of Testing Techniques and Flow Diagnostics to Advance Aerodynamic Ground Simulation".

This Technical Memorandum has been reviewed and is approved.

JOSEPH M. HAMPLE, Chief
Experimental Engineering Branch
Aeromechanics Division

ABSTRACT

A method for designing pneumatic systems for minimum response times, which includes the use of a computer program, is described in detail. The application of this method to modify the design of a five hole flow angularity probe is discussed. The original and modified probes were both tested in the laboratory for pneumatic response to step pressure increases at pressures from 1.0 to 2.6 mm Hg, absolute. Equipment, procedures, and results from the laboratory experiments are described in detail.

TABLE OF CONTENTS

	<u>PAGE</u>
1.0 INTRODUCTION	1
2.0 THEORETICAL WORK	2
2.1 Viscous Flow Calculations	2
2.2 Viscous, Transition and Molecular Flow Calculations	5
3.0 PROBE DESIGN AND FABRICATION	8
4.0 EXPERIMENTAL WORK	10
5.0 DISCUSSION AND CONCLUSIONS	13
6.0 SUMMARY	16
REFERENCES AND ACKNOWLEDGEMENTS	33
APPENDIX	34

LIST OF FIGURES

<u>FIGURE</u>		<u>PAGE</u>
1	Optimum Relations Between d_1 and d_2	18
2	Original Probe	19
3	Modified Probe	20
4	Dimensional Comparison of Probes	21
5	Low Pressure Stabilization Simulator Schematic	22
6	Low Pressure Stabilization Simulator Setup	23
7	Valve Assembly - Top View	24
8	Tank - Front View	25
9	Comparison of Original and Modified Probe Response.	26
10	Original 5-Orifice Flow Field Probe - Comparison of Measured and Calculated Response Times - 90% Response	27
11	Modified 5-Orifice Flow Field Probe - Comparison of Measured and Calculated Response Times - 90% Response	28
12	Comparison of Calculated Response Times for Original and Modified 5-Orifice Flow Field Probe - 90% Response	29
13	Comparison of Measured Response Times for Original and Modified 5-Orifice Flow Field Probe - 90% Response	30
14	Original 5-Orifice Flow Field Probe - Comparison of Response Time Ratio to Length-to-Diameter Ratio - 90% Response	31
15	Modified 5-Orifice Flow Field Probe-Comparison of Response Time Ratio to Length-to-Diameter Ratio - 90% Response	32

1.0 INTRODUCTION

When measuring low pressures on an aerodynamic model in hypersonic flow, a problem that arises is that there is a lag time between a pressure change at an orifice on the model and the response of the transducer to that pressure change. When the wind tunnel is a hypersonic, high temperature, intermittent blow down type, it is essential to minimize this response time so that the maximum number of measurements may be acquired to assure cost effective testing. This general pressure system response problem has been addressed by many authors in the past, including Kendall (Ref. 2), who developed equations to optimize the pneumatic design and to predict response times in the viscous flow regime, and Cain (Ref. 3), who developed a computer program to predict this response time in the viscous, transition, and molecular flow regimes.

In this report, a procedure for the use of Kendall's design equations is described which enables one to quickly determine several possible optimum pneumatic designs for a given situation. The use of Cain's program to predict the response time of the system to the expected pressure changes is discussed next. Then, the use of these methods in the redesign of a five-orifice flow field pressure probe is discussed. Next, the use of an in-house developed experimental apparatus, called a "Low Pressure Stabilization Simulator", is discussed. This device, still under development, is used to measure the probe response times under simulated wind tunnel conditions. Results of these tests to date are discussed. Finally, the test results are analyzed, the conclusions are discussed, and the basics for the design method are briefly summarized.

2.0 THEORETICAL WORK

A way to determine the validity of the continuum assumption is to calculate the Knudsen Number. The Knudsen Number is defined by:

$$KN = \lambda / \ell$$

where " λ is the mean free path or the average distance which a typical molecule travels between collisions and ℓ is a typical length of the problem" (Ref. 1). λ is a function of pressure and temperature, and, with tubing systems, ℓ is equal to the tube radius. The Knudsen Number is used to define three basic flow regimes. They are:

KN < .01 - VISCOUS

.01 < KN < 1 - TRANSITION

KN > 1 - MOLECULAR

Several theories have been developed to mathematically predict the response time for a tubing system in each of these regimes.

2.1 VISCOUS FLOW CALCULATIONS

The computational methods described in this section were developed by J. M. Kercall (Ref. 2), and they are valid assuming that the flow is viscous and isothermal, the Reynolds Number, based on the tube radius, is less than 1000, the flow does not involve slip, outgassing is neglected, the transducer volume remains constant under varying pressure, and the pressure distribution throughout the length of a tube is dependent only on the end pressures.

Tubing systems often consist of a single tube of constant diameter the entire length from the orifice to the pressure transducer. If, however, this single diameter system does not yield an acceptable response time, then it is often possible to reduce the time by running the orifice-size tube only part way to the transducer, and then

attaching it to a larger diameter tube for the remaining distance; in some cases, two or three diameter increases of this nature are needed to sufficiently reduce the response time. Some general guidelines to follow to minimize response times are: make the orifice diameter, d_1 , as large as possible without interfering with the aerodynamic objectives of the particular test; if a multi-diameter system is being considered, then make the length of the orifice tube, ℓ_1 , as short as possible; for any system, the total length from the orifice to the transducer should be as short as possible; and the transducer should have a gage volume, V_G , that is the smallest available for the expected pressure and temperature ranges of the flow.

If a two diameter system is to be considered, then the optimum diameter of the second tube, d_2 , must be determined. The first step in doing this is to choose d_1, ℓ_1, ℓ_2 , and V_G according to the above guidelines. Next, two dimensionless constants, $\beta = 8V_G/d_1^2 \ell_1$ and ℓ_2/ℓ_1 , must be calculated and used to locate d_2/d_1 on the graph in fig. 1. Multiplication of d_2/d_1 by d_1 then yields the optimum d_2 for the particular system being considered. Once d_2 is determined, then the equivalent length, L , and volume, V , based on d_1 , may be calculated, where,

$$L = \ell_1 + d_1^4 \left[\frac{\ell_2}{d_2^4} \right]$$

and

$$V = V_G \quad (d_2 \leq 3d_1)$$

or

$$V = V_G + \pi/4 \left[d_2^2 \ell_2 \right] \quad (d_2 > 3d_1)$$

These values are then used in Kendall's equation for calculating the response time of a transducer when the orifice pressure is decreased. The derivation of this equation is described in his report (Ref. 2), and the final result is

$$t = \frac{128\mu LV}{\pi D^4 g_c P_2} \ln \frac{(P_0 - P_2)(P_0 + P_2)}{(P - P_2)(P_0 + P_2)}$$

where,

μ = Poises viscosity for air = 1.8×10^{-4}

g_c = a conversion factor which changes dynes/cm² to microns = 1.333

L = total tube length for single tube systems, or the equivalent length, L , for two tube systems (cm)

V = V_G for single tube systems, or the equivalent volume, V , for two tube systems (cm³)

D = d_1 for single and two tube systems (cm)

P_0 = initial pressure of entire system (microns)

P_2 = final orifice pressure where $P_2 < P_0$ (microns)

P = final pressure read by transducer, allowing for acceptable response error in readings = $P_0 + (\% \text{ RESPONSE}/100) \times (P_2 - P_0)$ (microns)

By using the methods described in this section, several possible tubing systems for a particular application may be designed and compared to one another quickly and cheaply. The curves in fig. 1 may be used to calculate an optimum d_2 for several possible combinations of d_1, ℓ_1, ℓ_2 , and V_G . Next, the viscous response times for the two tube, as well as the one tube, systems may be calculated for the expected pressure regions. These response times can then be used as an initial comparison between the designs.

2.2 VISCOUS, TRANSITION AND MOLECULAR FLOW CALCULATIONS

The primary purpose of this section is to instruct the reader in the use of a computer program which was developed by Maurice R. Cain (Ref. 3). The program is written in FORTRAN IV and it is designed to predict the response times of a transducer to orifice pressure changes during a pitch-pause type of tunnel run; the time involved in pitching the model is not included in the calculations.

This program is capable of predicting response times of a transducer to an orifice in the viscous, transition, and molecular flow regimes. The program operates by first calculating the initial and final Knudsen Numbers, KN , for any given step pressure change. If $KN < .01$ throughout, then the response times are found by the direct application of viscous flow equations; if $KN > .01$ throughout, then viscous flow equations are used with correction factors in an iteration process; if KN passes through $KN = .01$ then the transition point is calculated and the viscous flow equations are used without correction factors for $KN < .01$ and with correction factors for $KN > .01$.

The required inputs for this program include the system geometry, percent response of the transducer to the pressure change, temperature of the system, initial pressure of the system, pitch angles, the orifice pressure at each pitch angle, and the orifice numbers. The geometry must be input, in inches, as a three tube system in the order $d_1, d_2, d_3, V_G, l_1, l_2, l_3$; if a two tube system is desired, then $d_2 = d_3$, and the sum of l_2 and l_3 is equal to the total length of the second tube; similarly, if a one tube system is desired, then $d_1 = d_2 = d_3$ and the sum of l_1, l_2 and l_3 is equal to the total tubing length. The percent response should be within the resolution capability of the particular

transducer being considered. The temperature is to be input in $^{\circ}\text{R}$, and it is assumed to be constant throughout the system. The initial pressure, in mm Hg, is the equilibrium pressure of the entire system when time is equal to zero. The pitch angles are whole angles, in degrees, that the model will be pitched to during the run - these are not used in the computations and are intended as a bookkeeping aid for the user. The orifice pressures, in mm Hg, are the new pressures at each orifice at each new pitch angle. The orifice number is an integer which, again, is included as a bookkeeping aid for the user. Any single data deck may contain a maximum of 12 geometries, 9 errors, 3 temperatures, 5 initial pressures, 30 pitch angles and orifice pressures, and 20 orifices.

When the program is run, the output always includes a list of the above inputs. The values that are calculated are printed in columns titled KN, KM, F/FV, P. TRANS, ST. TIME, TOT. TIME, RE1, RE2, RE3, ACC1, ACC2, and ACC3. KN is the Knudsen Number, KM is a constant used in the computations which is dependent on temperature and geometry, and F/FV is a correction factor which has been applied to the viscous flow equations. P. TRANS is the pressure at the transducer which differs from each orifice pressure by the error specified in the input. ST. TIME is the stabilization time, in seconds, for each pressure change and TOT. TIME is the sum of the ST. TIMES. RE1, RE2, and RE3 are the Reynolds Numbers in the three tubes, while ACC1, ACC2, and ACC3 are acceleration factors in the three tubes. The Reynolds Numbers and acceleration factors are only calculated when the flow is viscous, and

they serve as a check for the validity of the program in this regime; RE must be less than 2000 and ACC must be 1 or greater in all three tubes or the program will not be valid.

A sample of the program input and output is included in the Appendix. A complete listing of this program may be found in reference 3.

3.0 PROBE DESIGN AND FABRICATION

A problem that prompted the research included in this paper was that a five-orifice flow field probe was needed for measurements in the 20-inch, Mach 14 Wind Tunnel, which is operated by the Aeromechanics Division. First, an already existing probe was tried for this test, but the response times of the static pressure ports were as long or longer than tunnel run times for some phases of the desired test. The Experimental Engineering Branch was then asked to redesign the probe to solve this problem. This redesign was accomplished according to the methods described in sections 2.1 and 2.2, and a new, modified probe was fabricated. The modified probe is still within the aerodynamic requirements for the test, but its response time is considerably reduced from that of the original probe.

The original and modified probes are of similar design and construction. Each probe consists of a probe tip, body, and pressure tubes. The probe components are stainless steel and probe assembly is accomplished by silver soldering.

The original probe is illustrated in fig. 2. The probe tip is a 40° included angle cone followed by a 5° angle which tapers back to the 0.156 inch probe body diameter. The probe tip has five 0.020 inch diameter holes; one total pressure hole at the point and four static holes located 90° apart, 0.139 inches back from the apex. The probe body is made from a piece of 0.156 x 0.123 x 3.5 inch tubing. The pressure tubing is 0.032 x 0.020 x 72.00 inch stainless steel. The effective length and diameter of the tubing is then $l=72.3$ inches and $d=0.020$ inches.

Using the constraints that the modified probe should be approximately the same size and shape as the original probe several tubing standard diameter and length combinations were entered into the pressure response time program. The optimum configuration, as determined by the program, is shown in fig. 3. The probe tip is a 40° included angle cone which tapers to 0.156 inches, the same diameter as the original probe. The probe tip has a 0.020 inch diameter total pressure hole and four 0.032 inch diameter static holes, located 90° apart, 0.184 inches back from the apex. The modified probe body is fabricated from a piece of tubing 0.156 x 0.123 x 3.50 inch which has been drilled out to a 0.136 inch inside diameter to accommodate the larger pressure tubing. The total pressure tubing is 0.032 x 0.020 x 3.875 inch which connects to 0.062 x 0.038 x 62.125 inch tubing. The static pressure tubing is 0.050 x 0.032 x 3.875 inch which connects to 0.062 x 0.050 x 62.125 inch tubing. The effective lengths and diameters of the total pressure tubing is then $l_1 = 4.20$ inches, $d_1 = 0.020$ inches, $l_2 = 62.125$ inches and $d_2 = 0.038$ inches. For the static pressure tubing the effective lengths and diameters are $l_1 = 4.20$ inches, $d_1 = 0.032$ inches, $l_2 = 62.125$ inches and $d_2 = 0.050$ inches. To improve response time, the overall length of the tubing for the modified probe was kept to the minimum required for sting mounting purposes, therefore, it is approximately 6 inches shorter than that of the original probe. Both probes are shown in fig. 4.

4.0 EXPERIMENTAL WORK

The final stage in the design of a low pressure measuring system is to test the actual system in the pressure range of interest. The Low Pressure Stabilization Simulator was designed with this purpose in mind. This Simulator is versatile enough to be used to test a tubing system already installed in a model in a facility (testing the entire pressure system from model orifice to computed output to ascertain responses, calibrate, or check for leaks or partially clogged tubes), or to test in the lab before tunnel installation. The design specifications for the Simulator state that it is for use in the range of 0.01 to 1.0 Torr, but no apparent problems have been found in using it to test at pressures higher than 1.0 Torr.

A schematic of the Simulator setup is shown in fig. 5. In a typical test setup the pressure tubes are installed in a model or probe which is secured to a Sting, and then the Tank is mounted so that it encloses the entire model or probe and seals around the Sting; the pressure tubes extend through the Sting and out the back of the Tank to the pressure transducers. The vacuum pump is then started and pneumatic valves E, L1 through L4, and S1 through S4 are opened until the entire system is outgassed and pumped down to the desired starting pressure. Next, valve E and all of the L valves are closed. The pressure in the reservoirs between the L and S valves is then raised by opening the atmospheric shutoff valve and the Solenoid and Needle valves; the low pressure in the system draws air in from the atmosphere, through the air dryer, and into the reservoirs. The pressure in the reservoirs is read on the Diaphragm gage, and the Solenoid and Needle valves are manipulated to adjust this to the desired pressure. The S valves are

now closed. At this point, the starting pressure and leak rate can be checked with a Pirani gage which is connected to the Tank. Step pressure increases can now be made in the Tank by opening valves L1, L2, L3, and L4 one at a time to allow the higher pressure air in the reservoirs to enter the Tank; the Tank volume to Reservoir volume ratio is approximately 1000 to 1, so if the Reservoir pressure is 100 Torr, the step increase in the Tank will be 0.1 Torr. The pressure increase in the Tank is read on an M.K.S. Baratron Gage, while the transducer pressure response with time can be recorded on a strip chart recorder. The time for the transducer pressure to reach the Baratron pressure is the full response time.

A picture of the overall Simulator setup as it was used in the lab is shown in fig. 6. The Control Console contains the Atmospheric Shutoff, Needle, and Solenoid valves, the air dryer, the Diaphragm gage, the Pirani gage, and the buttons for operating valves E, L1 through L4, and S1 through S4. The Atmospheric Shutoff valve is on the side panel, and the Needle and Solenoid valves are operated by a knob and a button, respectively, on the front of the console. The Diaphragm gage is a mechanical gage, and the Pirani gage reads the pressure in the Tank from a Pirani gage tube. On the back of the Control Console, is a coupling plug to allow the air from the air dryer to proceed to the reservoirs in the Valve Assembly. The Valve Assembly (fig.7) contains the S and L valves and the reservoirs between them; the valves are operated by a supply of 60 psi field air and they allow dry air from the Control Console to enter the reservoirs, and then discharge as step pressure increases to the Tank. Mounted on the Tank (fig. 8), are valve E, the

Pirani gage tube, and an inlet to the sensing side of the Baratron gage. The device which responds to the step pressure increases is the Baratron Sensing Head. This Sensing Head must be connected to the vacuum system from the reference port and to the Tank from the sensing port; a valve crossover from the vacuum system to the sensing port is included so that the gage may be zeroed before testing is begun.

The only tubing systems that have been tested in this Simulator to date are the two probes discussed in Section 3.0. The responses from these tests for a 1 to 2 mm Hg step change for the original and modified probes are illustrated by the two curves in fig. 9. From these curves, it can be seen that the measured time for the modified probe to fully respond to the orifice pressure change is approximately one-tenth of the time required by the original probe. This improved response was acceptable for the wind tunnel requirements, and so the modified probe has been scheduled for wind tunnel testing.

By using the Low Pressure Stabilization Simulator, one may subject a low pressure tubing system to small step pressure increases. The response times measured in the Simulator should give an accurate prediction of the response times that can be expected during actual wind tunnel tests.

5.0 DISCUSSION AND CONCLUSIONS

The two probes described in Section 3.0 were tested in a sequence of 0.2 mm Hg step increases from 1.0 to 2.6 mm Hg, in addition to the 1.0 to 2.0 mm Hg step discussed in Section 4.0. The data from these tests is plotted in figs. 10, 11, 12 and 13. The data points on these graphs represent response times, for stabilization to within 90 percent of the pressure change at the probe orifice, for the pressure increments indicated on the horizontal scale. In figs. 10 and 11, the measured response times are compared to the time calculated by the computer program for the original probe and the modified probe, respectively. In fig. 12 the calculated times for both probes are compared, and in fig. 13 the measured times for both probes are compared.

From figs. 10 and 11, the ratio of measured to calculated response time was between 2.8 and 4.8 for the original probe, and between 1.7 and 1.9 for the modified probe; the average for these ratios was 3.7 for the original probe and 1.7 for the modified probe. From figs. 12 and 13, the ratio of original probe to modified probe response time was between 4.5 and 5.2 for the computer calculations, and between 8.8 and 11.3 for the Simulator measurements (excluding the highest and lowest values of 14.4 and 8.6); the average for these ratios was 4.9 for the computer calculations and 10.5 for the Simulator measurements.

Several observations can be made from these ratios. First, the response times measured in the Simulator are consistently higher than those calculated by the computer. Second, as the absolute pressure for the 0.2 mm Hg step change is increased, the measured response time decreases on an approximate parabolic curve, which is also a trend found in the computer calculated response times. Finally, both the Simulator

measurements and the computer calculations showed a significant decrease in response time from the original to the modified probe; the measured decrease was approximately twice the predicted decrease.

The discrepancies between the measured and the calculated response times may be due to a "starting" phenomenon - a lag time in the development of fully established flow. M. Cain (Ref 3) observed errors between the calculated and measured response time data for length-to-diameter ratios greater than 500 ($L/D > 500$) in the transition flow regime and attributed these errors to this phenomenon. These experiments were conducted in the transition flow regime, and the probes had L/D ratios (total length divided by average diameter) of 3650 and 1590 for the original and modified probes, respectively. In order to compare the measured and calculated data better, it has been plotted in figs. 14 and 15 as the ratio of measured-to-calculated response times as a function of the pressure increment for the original and modified probes, respectively. These plots also include a dashed line of the value of $.001 \times (\Sigma L/D_{avg})$ for each probe. It appears that, for this set of data, a significant improvement in agreement between the measured and calculated response times can be achieved simply by multiplying the computer calculated time by $.001 \times (\Sigma L/D_{avg})$. Further testing will be required to determine the validity of this relationship for the general case.

In conclusion, it does appear that the computer program, in its current form, is useful for comparing tubing geometries relative to one another. However, for the flow regime and tubing geometries tested, predicted response times were 70% to 380% smaller than the measured values. Therefore, further testing is recommended to determine the cause for these discrepancies. Efforts should be directed toward determining if these errors are due to undetected flaws in the test setup or inaccuracies in the computer program.

Flaws in the test setup could include crimped tubing within the original probe body, added volume and reduced conductance due to pressure fittings, transducer malfunction, and strip chart malfunction. Inaccuracies in the computer program could exist because the correction factors used in it were derived from a limited amount of data; only a few pressure ranges and tubing geometries were used by M. Cain in developing this program. Also, the computer program was developed from data where dry nitrogen was the medium, but the tests described in this report used ambient air as the medium. Finally, the effect of the "starting" phenomenon on the response time of tubing geometries with large L/D ratios in transition flow must be investigated and incorporated into the program.

6.0 SUMMARY

In the design of any low pressure measuring system, the first thing to consider is the physical limitations in the wind tunnel test of interest. The first limit is the maximum orifice diameter which will not interfere with the aerodynamic objectives of the test. In general, for the purpose of improving pneumatic response, the initial orifice diameter should be as large as permissible, the overall length from the orifice to the transducer should be kept to a minimum, and, if a multi-tube system is being used, the length of the first tube should also be held to a minimum. Three other factors to consider are the pressure ranges to be measured, the required accuracy in these measurements, and the temperature of the flow. These conditions all affect the choice of transducer. In general, the transducer should have the smallest gage volume available in the desired pressure and accuracy ranges, and it should be as close to the orifice as possible without exposing it to extreme flow temperatures.

Once these limitations have been established, several possible single tube geometries may exist. A quick comparison of these geometries may be made by calculating their response times with the viscous flow equations in Section 2.1. Next, two-tube geometries, using the orifice sizes, overall lengths, and gage volumes from the one-tube geometries, may be calculated using the equations in Section 2.1 along with the curves in fig. 1. The results from these calculations may then be used in the viscous flow equations in Section 2.1 to calculate the response times for the two-diameter tube system. The various one and two diameter systems may then be compared for viscous response time. It

should be noted that even though the response time equation in Section 2.1 uses viscous flow assumptions, it is still often a valuable tool for obtaining a fast comparison between one and two diameter systems in the transition region. The curves in fig. 1 for calculating the optimum value of d_2 also use viscous flow assumptions. It has been found that the sizes for d_2 found in this manner are still valuable when searching for stock tubing to be used as the second tube. In general, a stock tube with an inside diameter just under the size calculated for d_2 , will give the best possible response times.

Once these one and two diameter tube systems have been compared using these viscous flow equations and the available stock tubing sizes have been determined, it may be possible to eliminate some of the designs as less desirable than others; it may also be possible to try adding a third, larger diameter tube, to some of the two-tube designs. The remaining one, two, and three diameter systems, using available tube sizes, may then be entered into M. Cain's FORTRAN IV program and a more accurate prediction of the response times may be obtained. From this, the system with the best predicted response time may be tested in the Low Pressure Stabilization Simulator. The data from these tests should accurately indicate the response times that can be expected during an actual tunnel run. If these times are satisfactory, then the system may be fabricated and installed in the tunnel for testing.

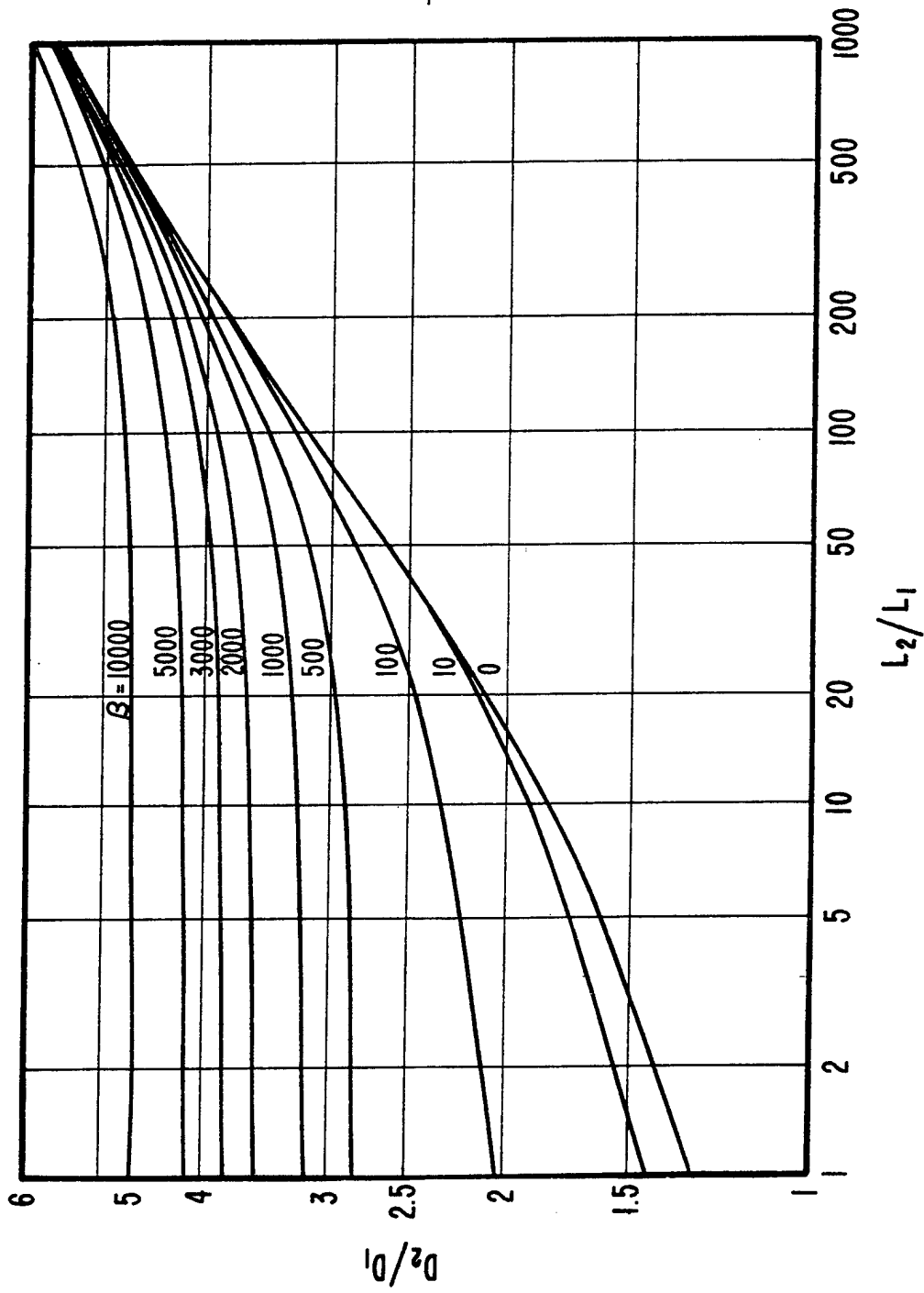

$$\beta = \frac{8V}{\pi D_1^2 L_1}$$

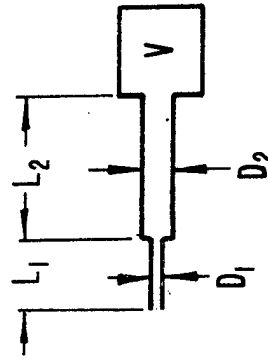

FIG 1. OPTIMUM RELATIONS BETWEEN d_1 and d_2

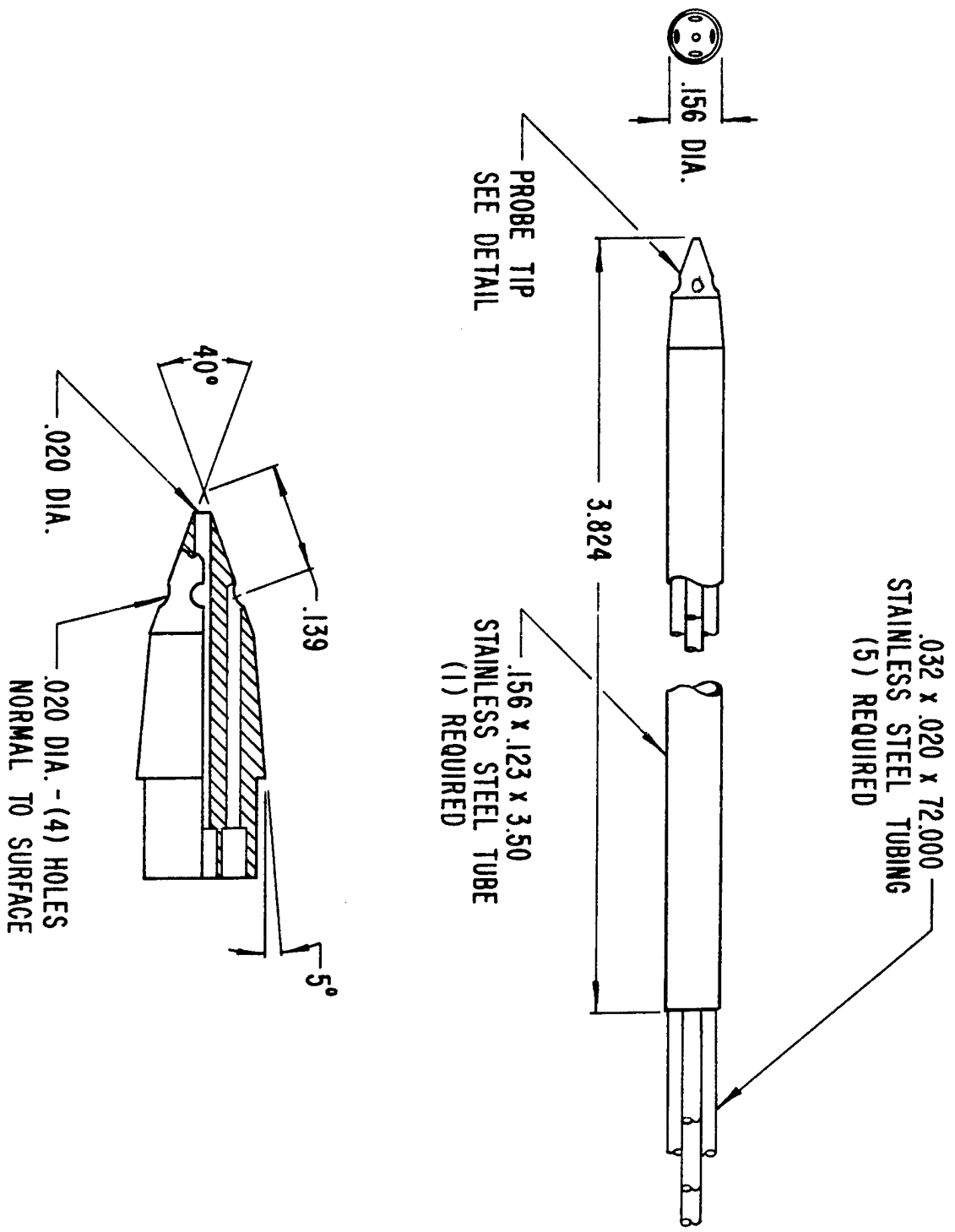

FIG 2. ORIGINAL PROBE

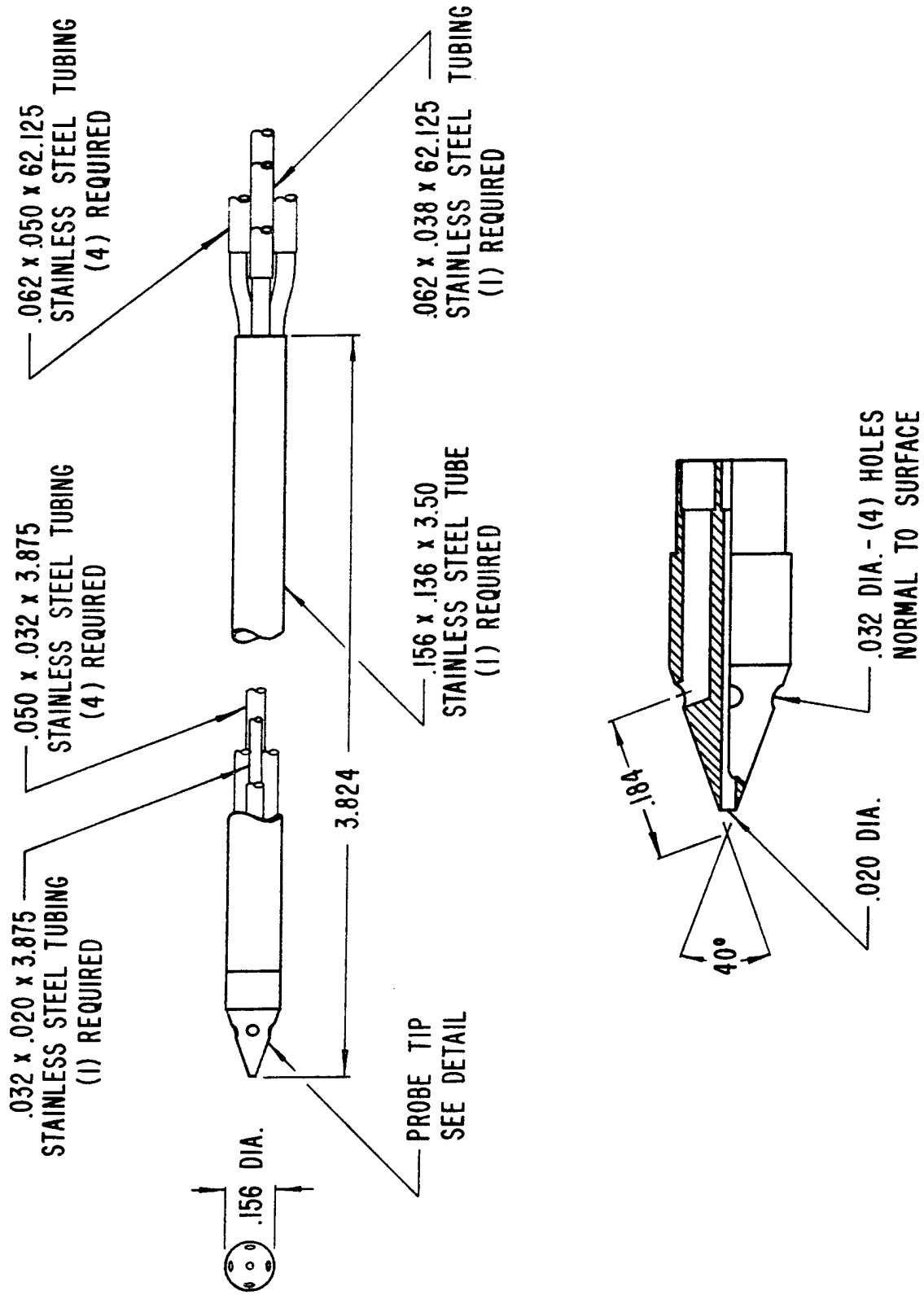

FIG 3. MODIFIED PROBE

ORIGINAL PROBE



cm
1 2 3 4 5 6

SPECIMEN _____ DATE _____



MODIFIED PROBE

FIG. 4 DIMENSIONAL COMPARISON OF PROBES

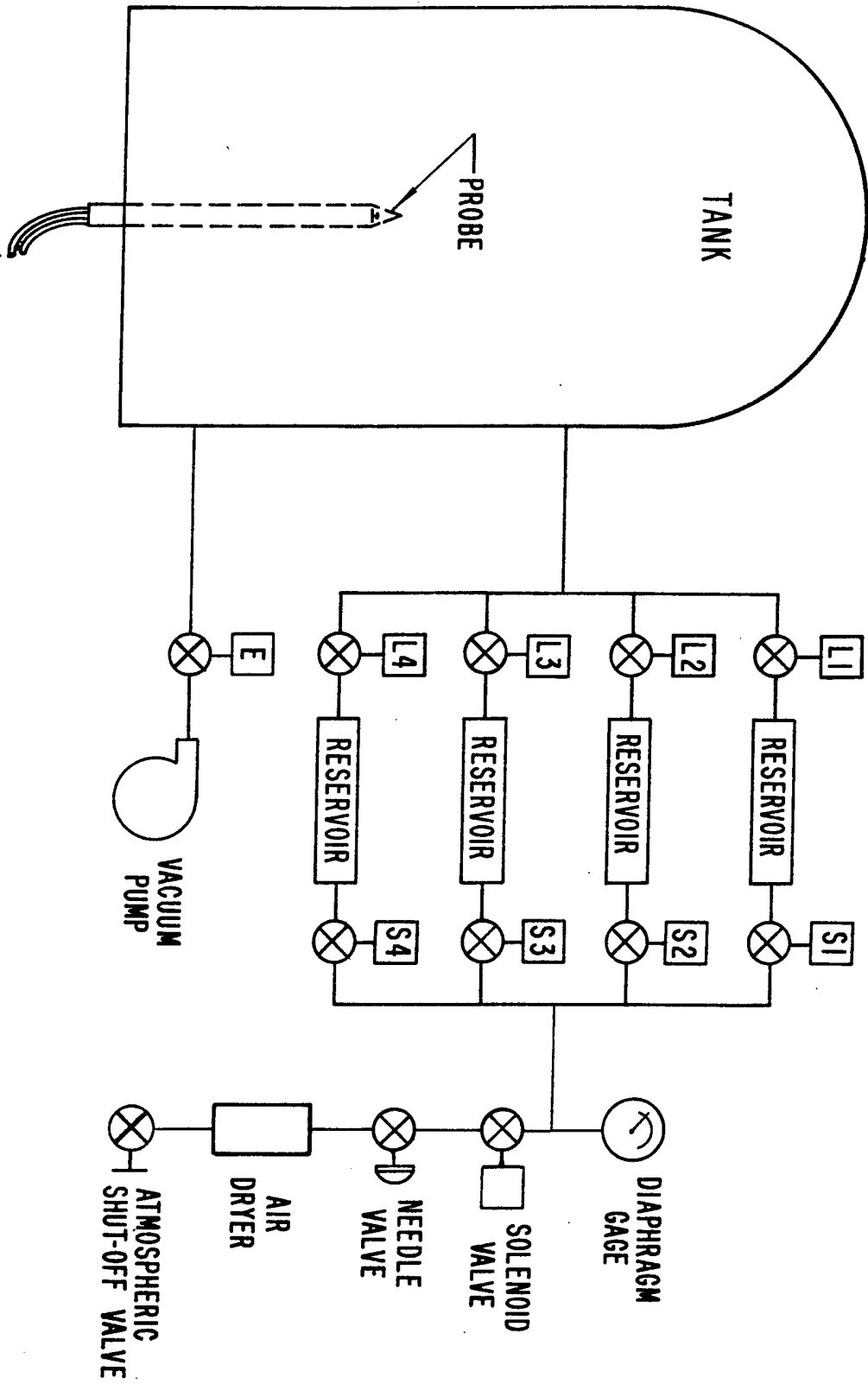

FIG 5. LOW PRESSURE STABILIZATION SIMULATOR SCHEMATIC.

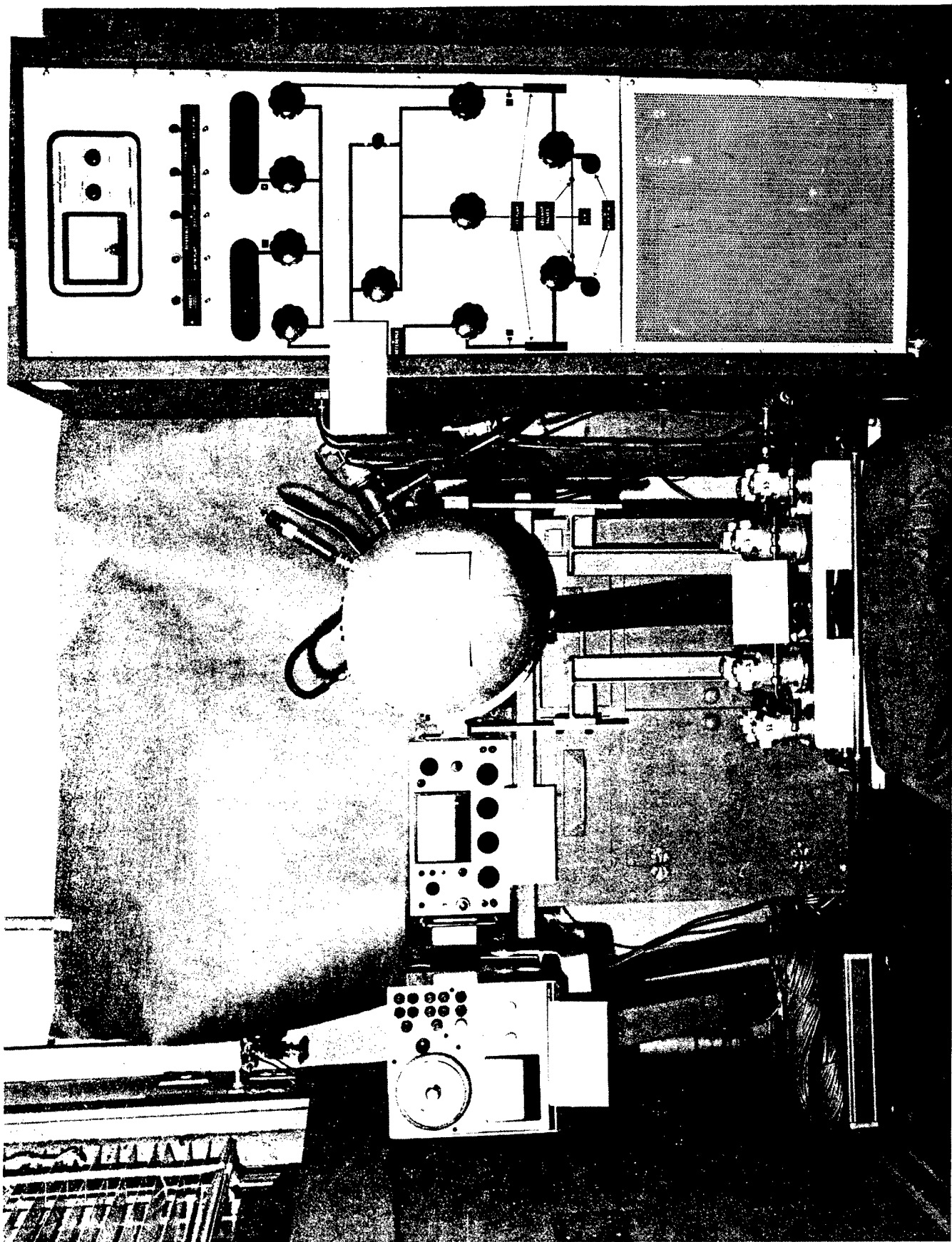

FIG 6. LOW PRESSURE STABILIZATION SIMULATOR SETUP.

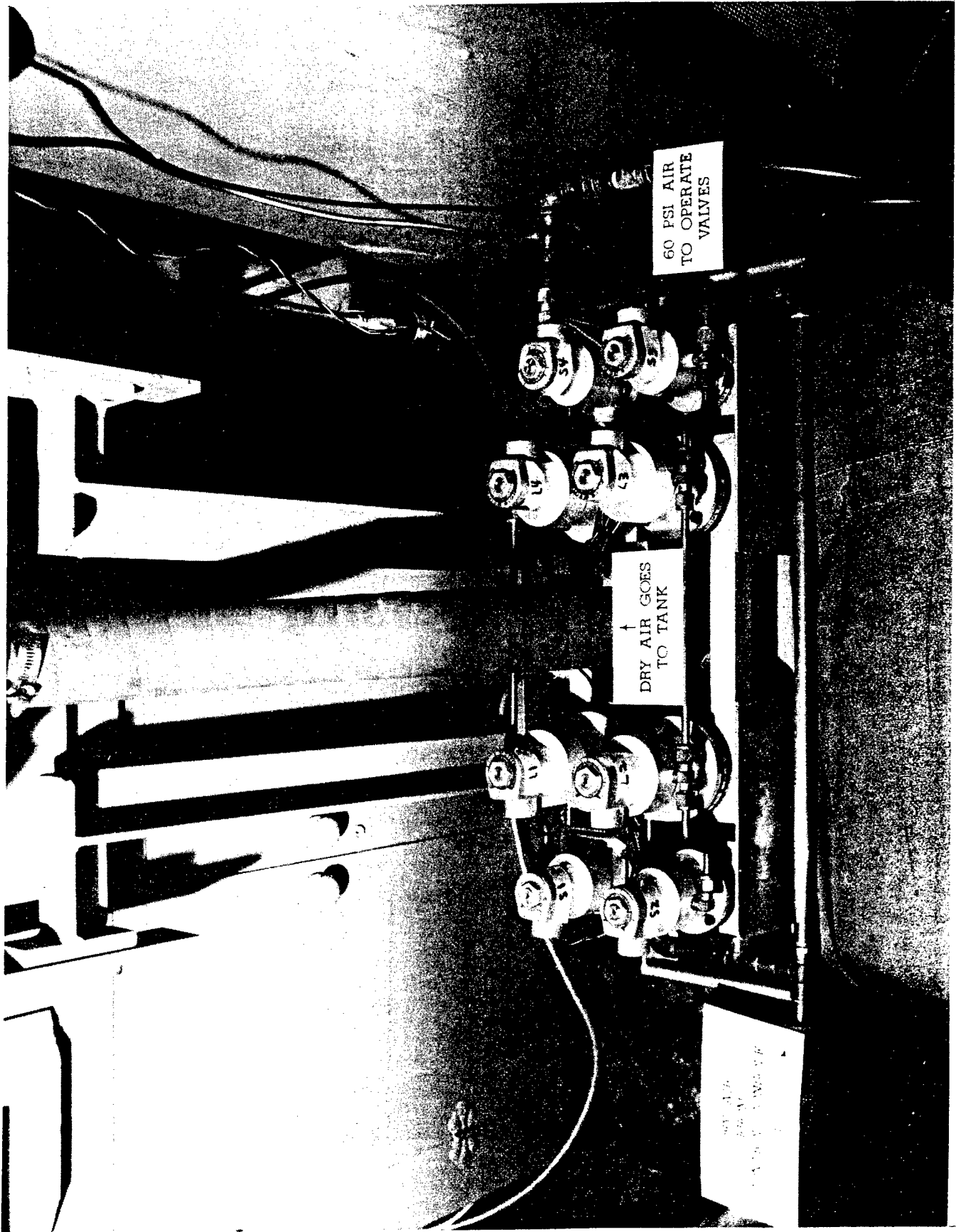

FIG 7. VALVE ASSEMBLY - TOP VIEW.

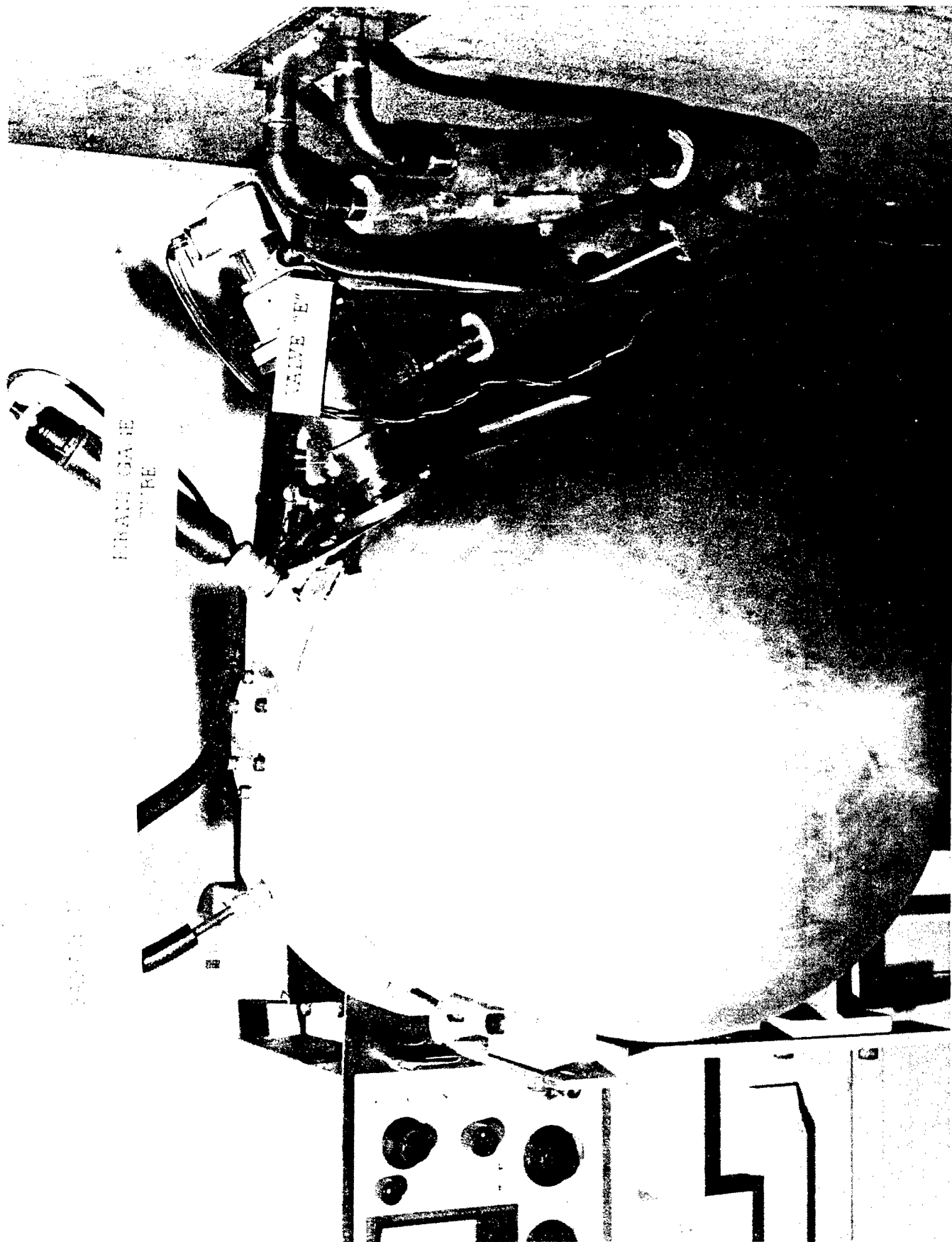

FIG 8. TANK - FRONT VIEW.

FLOW FIELD PROBE RESPONSE TIME

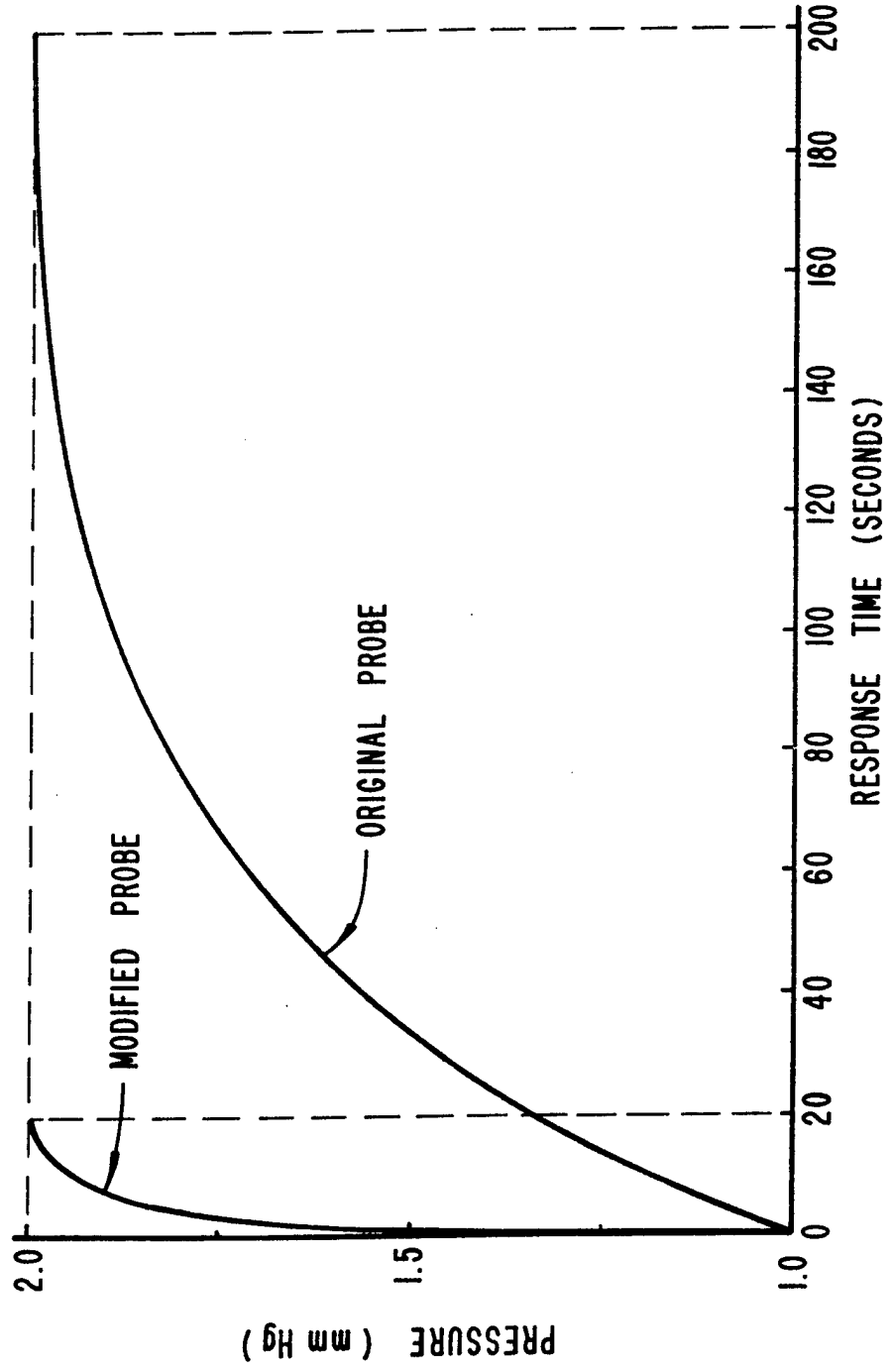

FIG 9. COMPARISON OF ORIGINAL AND MODIFIED PROBE RESPONSE.

ORIGINAL 5-ORIFICE FLOW FIELD PROBE
 COMPARISON OF MEASURED AND
 CALCULATED RESPONSE TIMES
 90% RESPONSE

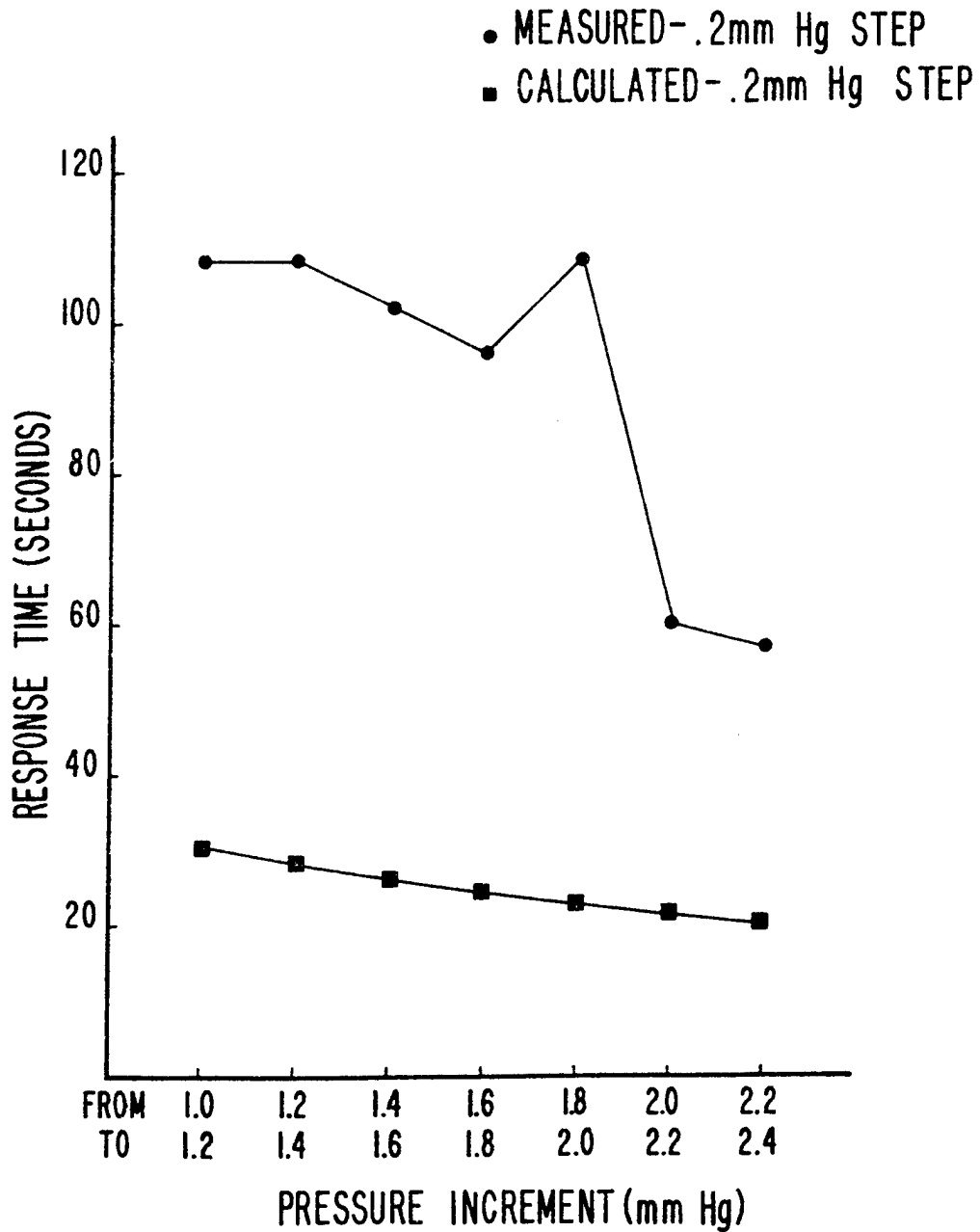

FIG. 10

MODIFIED 5-ORIFICE FLOW FIELD PROBE
 COMPARISON OF MEASURED AND
 CALCULATED RESPONSE TIMES
 90% RESPONSE

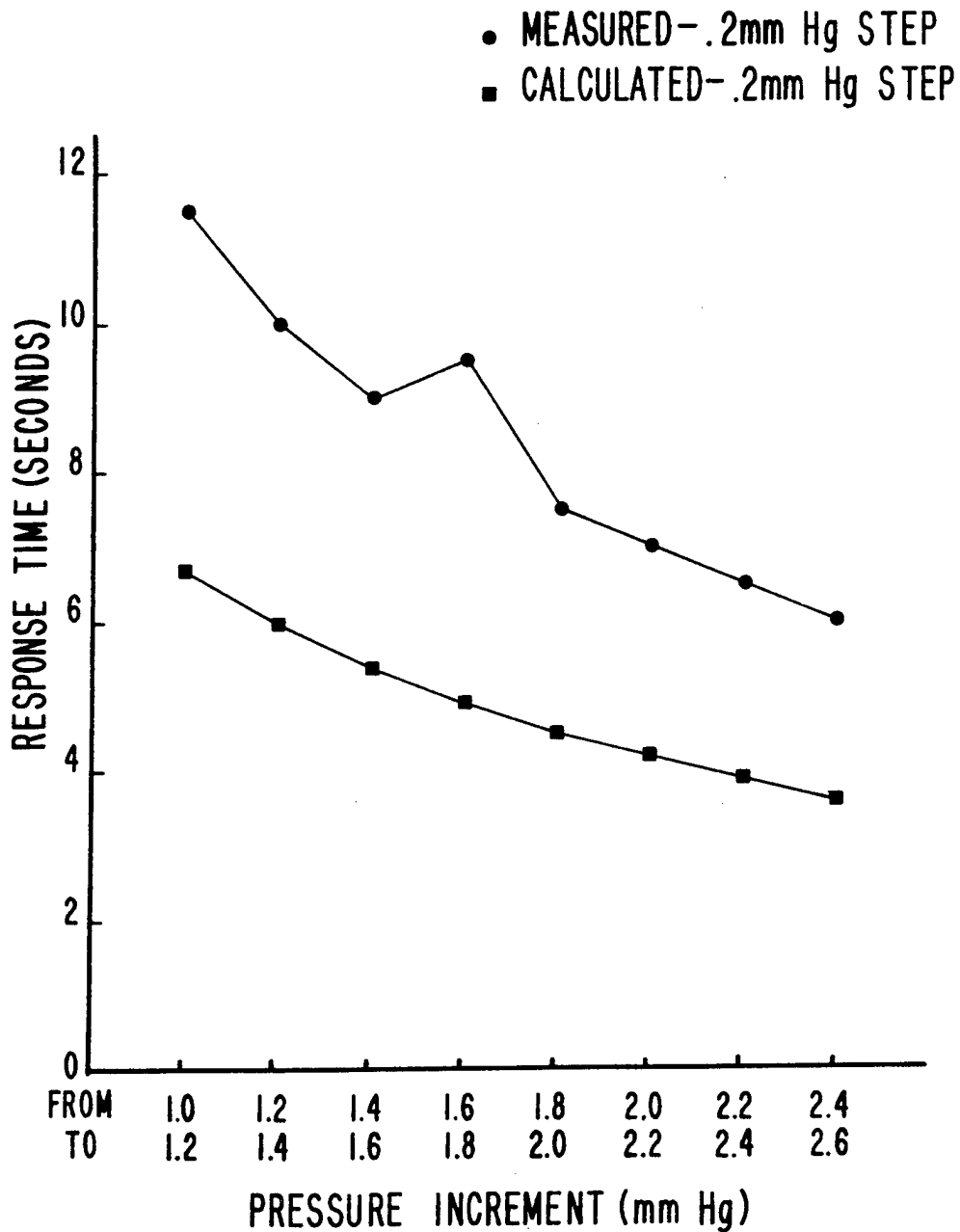

FIG. 11

COMPARISON OF
CALCULATED RESPONSE TIMES FOR
ORIGINAL AND MODIFIED
5-ORIFICE FLOW FIELD PROBE
90% RESPONSE

- ORIGINAL-.2mm Hg STEP
- MODIFIED-.2mm Hg STEP

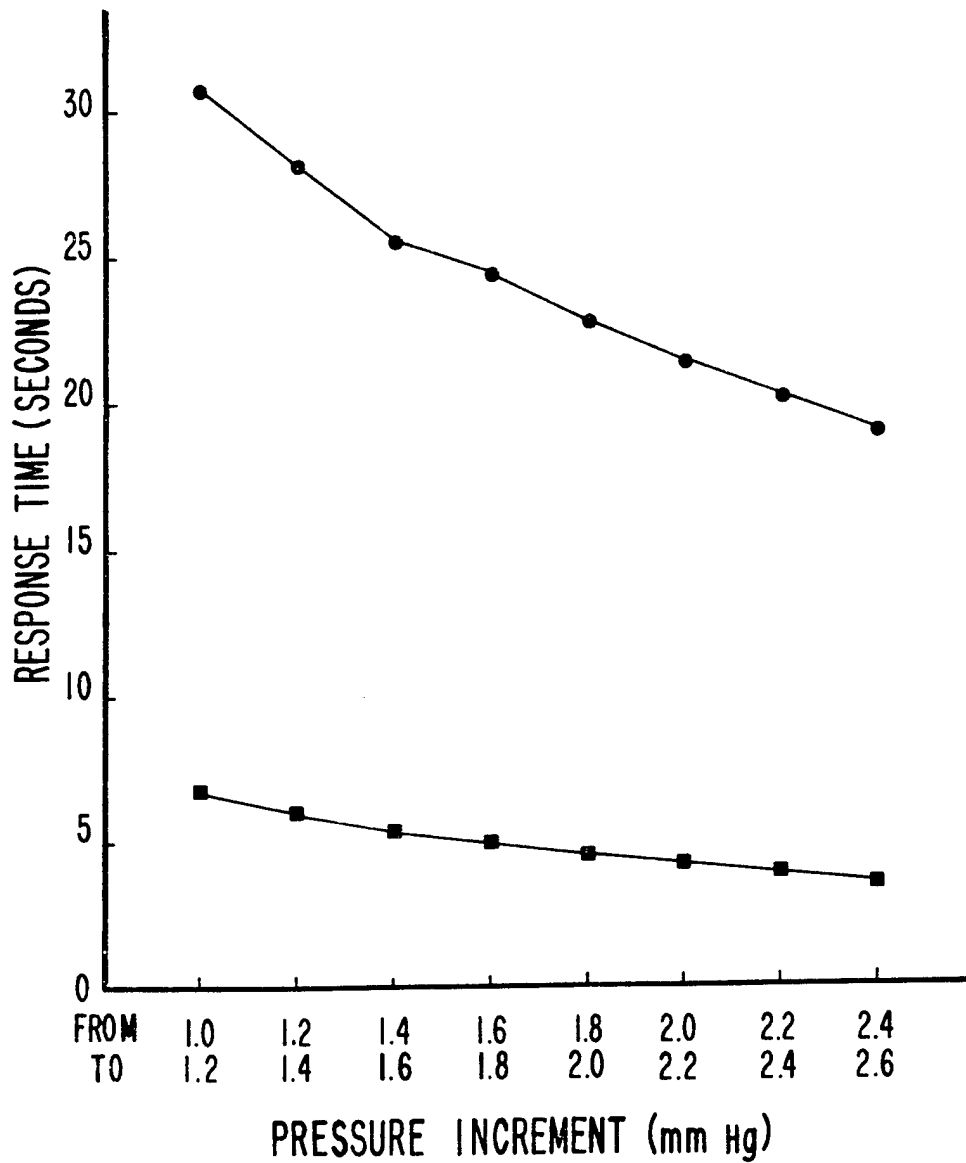

FIG. 12

COMPARISON OF
MEASURED RESPONSE TIMES FOR
ORIGINAL AND MODIFIED
5-ORIFICE FLOW FIELD PROBE
90% RESPONSE

- ORIGINAL-.2mm Hg STEP
- MODIFIED-.2mm Hg STEP

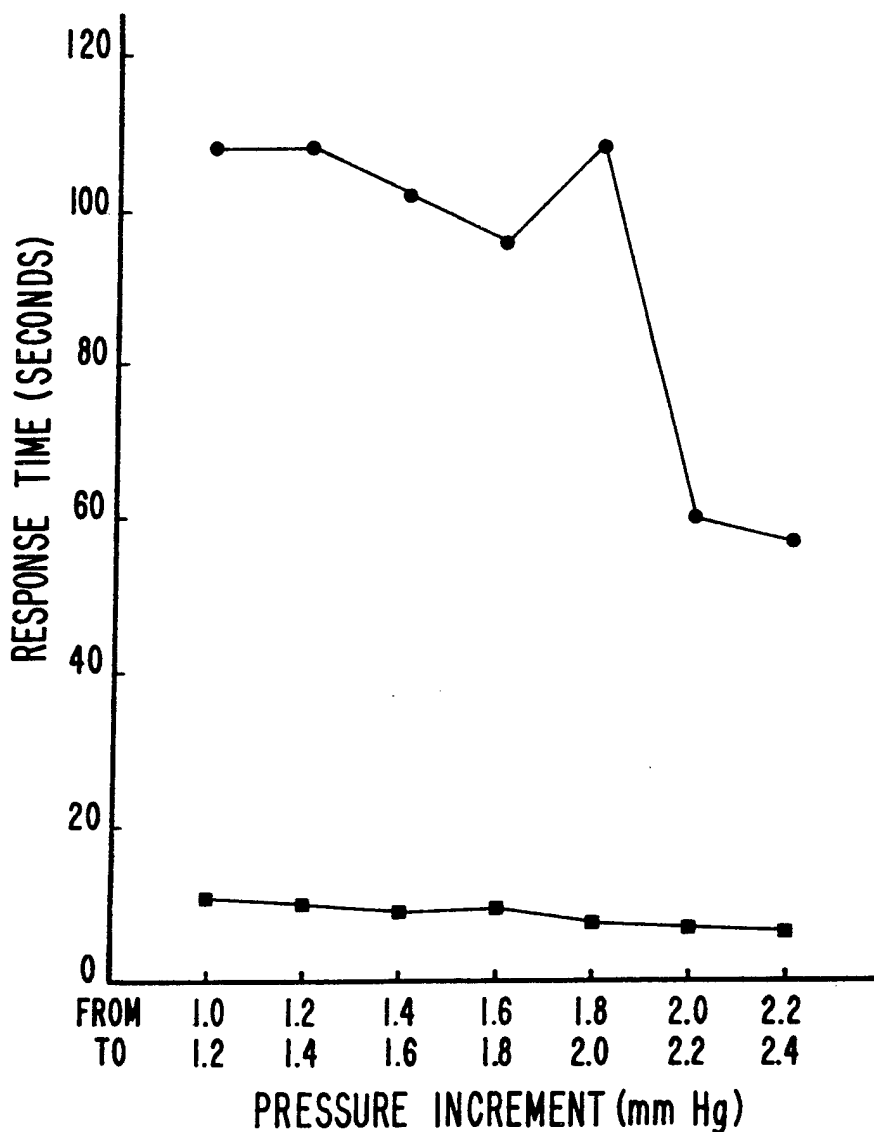

FIG. 13

ORIGINAL 5-ORIFICE FLOW FIELD PROBE
 COMPARISON OF RESPONSE TIME RATIO TO
 LENGTH - TO - DIAMETER RATIO
 90% RESPONSE

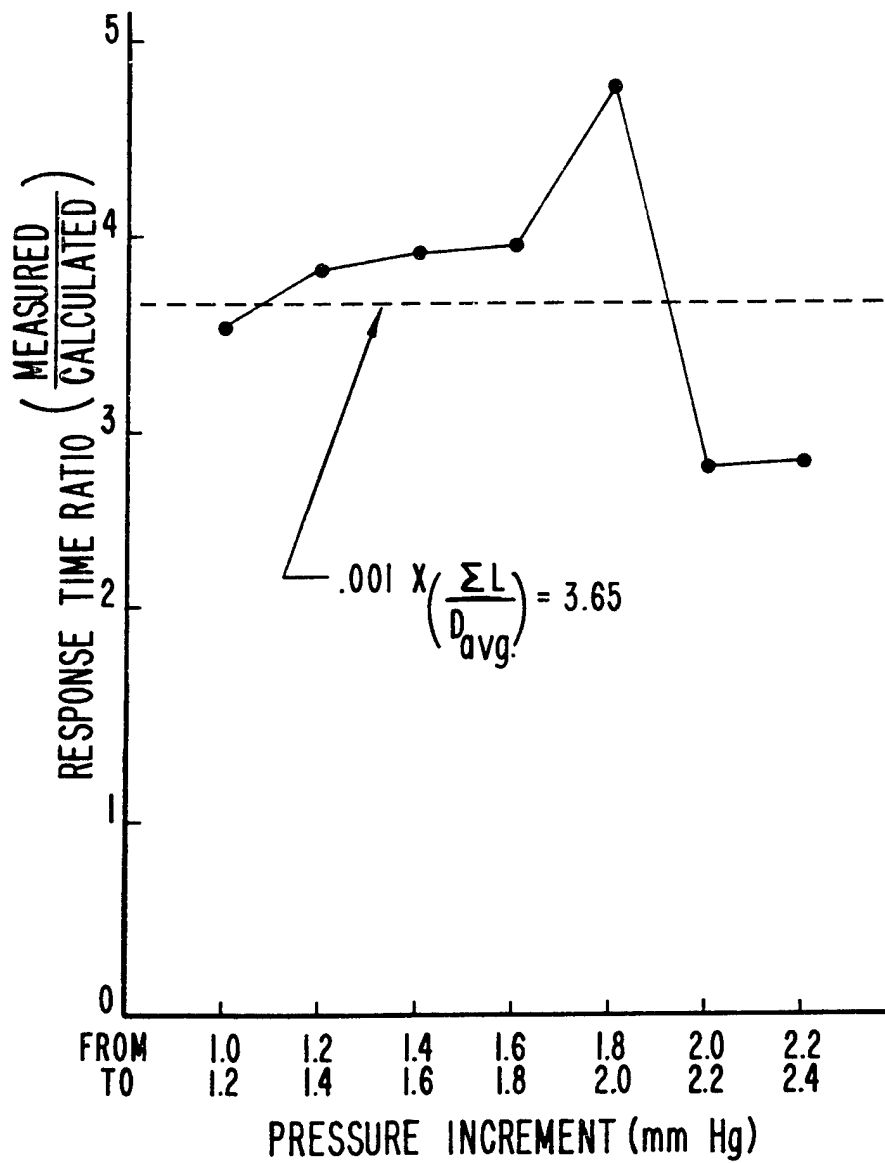

FIG. 14

MODIFIED 5-ORIFICE FLOW FIELD PROBE
 COMPARISON OF RESPONSE TIME RATIO TO
 LENGTH - TO - DIAMETER RATIO
 90 % RESPONSE

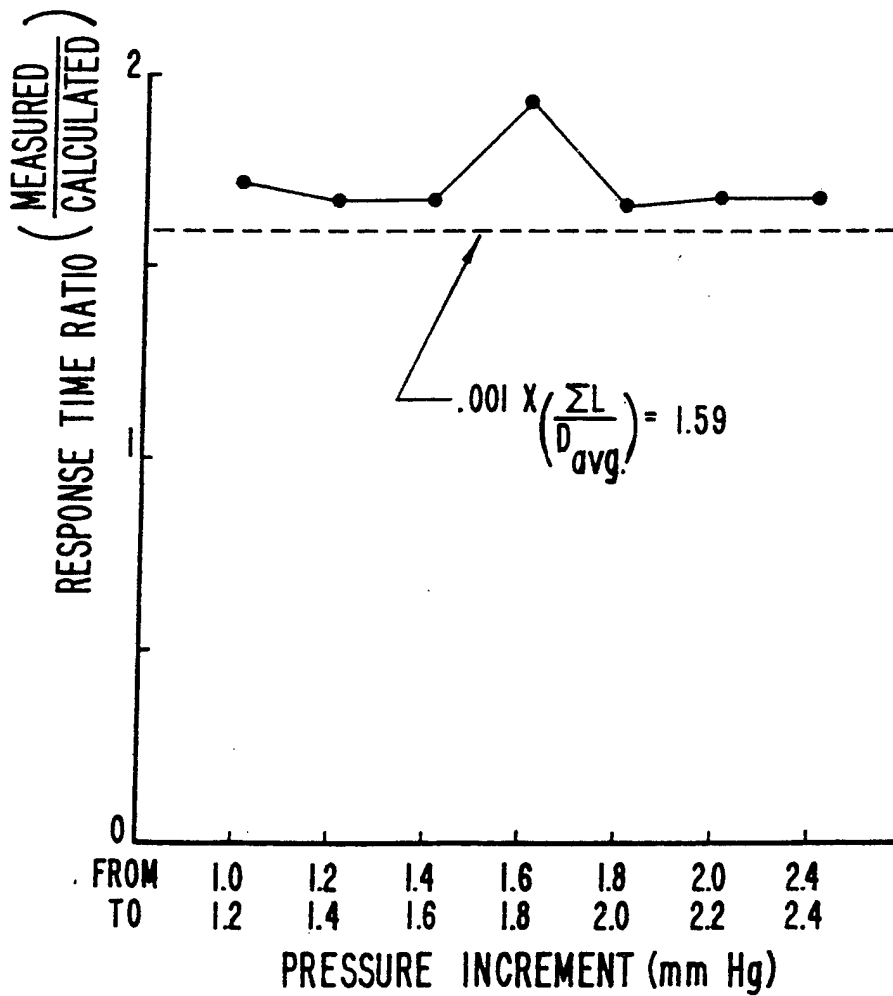

FIG. 15

REFERENCES

1. Gehart, P.M., "One-Dimensional Compressible Fluid Mechanics", Class Text, Department of Mechanical Engineering, The University of Akron, Akron, Ohio, 1979.
2. Kendall, J.M., "Optimized Design of Systems for Measuring Low Pressures in Supersonic Wind Tunnels", NATO, AGARD Report 174, March 1958.
3. Cain, M.R., "Prediction of Pressure Response in Low Pressure Flow Regimes", TM68-9 FDM, AFFDL, Wright-Patterson Air Force Base, Ohio, October 1968.

ACKNOWLEDGEMENTS

1. Baker, R.M., Private Communication, Retired Senior Engineer, Experimental Engineering Branch, WPAFB, Ohio, 9 July 1982.
2. Cain, M.R., Private Communication, Senior Engineer, Mechanical Systems Group, WPAFB, Ohio, June 1982.
3. Parobek, D.M., Private Communication, Technical Manager Mechanical Instrumentation Group, WPAFB, Ohio, June-August 1982.
4. Weiland, D.E., Private Communication, Senior Engineer, Mechanical Instrumentation Group, WPAFB, Ohio, June-August 1982.
5. Ford, J., Private Communication, Supervisory Technician, Mechanical Instrumentation Group, WPAFB, Ohio, June-August 1982.
6. Martin, J., Private Communication, Technician, Mechanical Instrumentation Group, WPAFB, Ohio, June-August 1982.

APPENDIX

Sample program inputs and outputs for program to calculate response times in the viscous, transition, and molecular flow regimes.

TYPE PRESSURE.DAT;1 - DATA FILE NAME
 01 - NUMBER OF RUNS
 TRIAL DATA DECK - TITLE OF RUN (MAXIMUM OF 80 CHARACTERS)
 00 - NO EXPERIMENTAL DATA
 01 02 02 01 05 01 00 - SEE BELOW
 099.000 - % RESPONSE FOR COMPUTED RESPONSE TIMES
 530.000 - TEMPERATURE, °R
 000.095000.095000.095000.305024.000040.000010.000 } GEOMETRIES IN INCHES
 000.095000.095000.095000.080024.000040.000076.000 } D₁, D₂, D₃, V₆, L₁, L₂, L₃
 000.500010.000 - INITIAL PRESSURES, mm Hg
 020.000015.000010.000005.000000.000 - PITCH ANGLES (USE WHOLE ANGLES IN DEGREES)
 01 - ORIFICE NUMBER
 000.220000.173000.134000.103000.085 - ORIFICE PRESSURE AT EACH ANGLE, mm Hg

01 1 ERROR

 02 — 2 GEOMETRIES

 02 — 2 INITIAL PRESSURES

 01 — 1 ORIFICE

 05 — 5 PITCH ANGLES

 01 — 1 TEMPERATURE

 00 — DO NOT PRINT OUT EACH
 CALCULATED STEP IN
 TRANSITION REGIME

INPUT - PRESSURE. DATA

\$ ASSION PRESSURE.DAT:1 FOR005 - IDENTIFIES PRESSURE.DAT AS INPUT DATA FILE
 \$ RUN RESPONSE

TRIAL DATA DECK

TAP	D1	D2	D3	VG	L1	L2	L3	RESPONSE	TEMP	F/FV	ALPHA	P.INIT.	P.DRIF.	P.TRANS.	ST.TIME	TOT.TIME
1	0.095	0.095	0.095	0.305	24.000	40.000	10.000	89.000	530.0	KM						
RE1	RE2	RE3	ACC1	ACC2	ACC3											
						KN										
						0.158	13.550	1.881	20.	0.500	0.220	0.223	23.541	23.541		
						0.225	13.550	2.259	15.	0.173	0.173	0.173	27.520	51.061		
						0.291	13.550	2.636	10.	0.134	0.134	0.134	30.426	81.487		
						0.380	13.550	3.143	5.	0.103	0.103	0.103	33.174	114.661		
						0.466	13.550	3.643	0.	0.085	0.085	0.085	35.067	149.728		

TAP	D1	D2	D3	VG	L1	L2	L3	RESPONSE	TEMP	F/FV	ALPHA	P.INIT.	P.DRIF.	P.TRANS.	ST.TIME	TOT.TIME
1	0.095	0.095	0.095	0.305	24.000	40.000	10.000	89.000	530.0	KM						
RE1	RE2	RE3	ACC1	ACC2	ACC3											
						KN										
						0.012	13.550	1.064	20.	10.000	0.220	7.981	0.116	0.116		
						0.051	13.550	1.283	20.	10.000	0.220	0.318	12.029	12.145		
						0.211	13.550	2.180	15.	0.318	0.173	0.174	26.880	39.025		
						0.291	13.550	2.634	10.	0.174	0.134	0.134	30.419	69.443		
						0.380	13.550	3.143	5.	0.134	0.103	0.103	33.174	102.617		
						0.466	13.550	3.643	0.	0.103	0.085	0.085	35.067	137.684		

TAP	D1	D2	D3	VG	L1	L2	L3	RESPONSE	TEMP	F/FV	ALPHA	P.INIT.	P.DRIF.	P.TRANS.	ST.TIME	TOT.TIME
1	0.095	0.095	0.095	0.080	24.000	40.000	76.000	89.000	530.0	KM						
RE1	RE2	RE3	ACC1	ACC2	ACC3											
						KN										
						0.158	22.341	1.881	20.	0.500	0.220	0.223	38.816	38.816		
						0.225	22.341	2.259	15.	0.223	0.173	0.173	45.376	84.192		
						0.291	22.341	2.636	10.	0.173	0.134	0.134	50.168	134.360		
						0.380	22.341	3.143	5.	0.134	0.103	0.103	54.698	189.059		
						0.466	22.341	3.643	0.	0.103	0.085	0.085	57.820	246.878		

TAP	D1	D2	D3	VG	L1	L2	L3	RESPONSE	TEMP	F/FV	ALPHA	P.INIT.	P.DRIF.	P.TRANS.	ST.TIME	TOT.TIME
1	0.095	0.095	0.095	0.080	24.000	40.000	76.000	89.000	530.0	KM						
RE1	RE2	RE3	ACC1	ACC2	ACC3											
						KN										
						0.017	22.341	1.093	20.	10.000	0.220	7.881	0.186	0.186		
						0.051	22.341	1.283	20.	10.000	0.220	0.318	19.834	20.020		
						0.211	22.341	2.180	15.	0.318	0.173	0.174	44.321	64.340		
						0.291	22.341	2.634	10.	0.174	0.134	0.134	50.156	114.496		
						0.380	22.341	3.143	5.	0.134	0.103	0.103	54.698	169.195		
						0.466	22.341	3.643	0.	0.103	0.085	0.085	57.820	227.015		

FORTRAN STOP