

AMPTIAC

NASA TECHNICAL TRANSLATION

NASA TT F-16,628

EXPLOSIVE-WELDED FIBER REINFORCED MATERIALS:
STATUS OF TECHNIQUE AND POSSIBILITIES OF DEVELOPMENT

E. Wolff

(NASA-TT-F-16628) EXPLOSIVE-WELDED FIBER
REINFORCED MATERIALS: STATUS OF TECHNIQUE
AND POSSIBILITIES OF DEVELOPMENT (Scientific
Translation Service) 22 p HC \$3.25 CSCL 13H

N75-33400

Unclas
G3/37 42312

RECEIVED

JUL 24 1981

MMCIAC

Translation of "Explosivgeschweisste Faserverbund-
werkstoffe — Stand der Technik und Entwicklung-
smöglichkeiten", Zeitschrift für Wirtschaftliche
Fertigung, Vol. 69, No. 6, June 1974, pp. 287-293.

DISTRIBUTION STATEMENT A
Approved for Public Release
Distribution Unlimited

20000712 108



NATIONAL AERONAUTICS AND SPACE ADMINISTRATION
WASHINGTON, D. C. 20546
OCTOBER 1975

Reproduced From
Best Available Copy

DTIC QUALITY INSPECTED 4

MMCIAC
000199

STANDARD TITLE PAGE

1. Report No. NASA TT F-16,628	2. Government Accession No.	3. Recipient's Catalog No.	
4. Title and Subtitle EXPLOSIVE - WELDED FIBER REINFORCED MATERIALS STATUS OF TECHNIQUE AND POSSIBILITIES OF DEVELOPMENT.		5. Report Date October 1975	
		6. Performing Organization Code	
7. Author(s) E. Wolff		8. Performing Organization Report No.	
		10. Work Unit No.	
9. Performing Organization Name and Address SCITRAN Box 5456 Santa Barbara, CA 93108		11. Contract or Grant No. NASw- 2791	
		13. Type of Report and Period Covered Translation	
12. Sponsoring Agency Name and Address National Aeronautics and Space Administration Washington, D.C. 20546		14. Sponsoring Agency Code	
		15. Supplementary Notes Translation of "Explosivgeschweisste Faserverbundwerkstoffe — Stand der Technik und Entwicklungsmöglichkeiten", Zeitschrift für Wirtschaftliche Fertigung, Vol. 69, No. 6, June 1974, pp. 287-293.	
16. Abstract A wide variety of fibers (boron, V2A, tungsten, molybdenum, etc.) have been successfully imbedded in a number of metal matrices (aluminum, nickel, zirconium, titanium) using an explosive welding technique. Semi-finished products can also be manufactured to provide shapes such as wing profiles, blades, etc. Tensile strengths measured have been as high as those above theoretically predicted. Mass production methods are also discussed. The materials are extremely heat resistant and it is thinkable that 150 cm fiber reinforced turbine blades could be made which could withstand temperatures up to 1100° C.			
17. Key Words (Selected by Author(s))		18. Distribution Statement Unclassified - Unlimited	
19. Security Classif. (of this report) Unclassified	20. Security Classif. (of this page) Unclassified	21. No. of Pages 22	22. Price

EXPLOSIVE-WELDED FIBER REINFORCED MATERIALS:
POSITION OF TECHNIQUE AND POSSIBILITIES OF DEVELOPMENT

E. Wolff

1297*

1. INTRODUCTION

Explosive welding is one of the methods of producing fiber-reinforced metals which has a special significance because of the universal applicability to almost all fiber/matrix combinations, regardless of their chemical compatibility or the melting points of their components. The first attempts to produce metallic fiber composite materials were carried out in 1968 in England [1]. Fundamental research was done in the United States on composite materials produced in this way [2, 3] and these experiments also started with a matrix in foil or sheet form as the initial material.

Fleck [4], however, attempted to produce explosive imbedding of metallic reinforcement fibers in a powder metal matrix. The strength properties of these composite materials, however, are not at all comparable with those which can be produced from a foil matrix, disregarding the fact that in every case the sintering process which follows and which is absolutely necessary leads to a considerable destruction of the composite material by diffusion between the composite components. Therefore, the

* Numbers in margin indicate pagination in original foreign text.

--	--	--	--	--	--	--	--

method becomes uneconomical and meaningless because of the high degree of complexity.

In 1970 the author carried out experiments for producing fiber-reinforced metals by explosive welding [5]. He used metal foil as the initial material again. A hollow body was prepared using special winding techniques which had fibers in the axis direction. The individual foil layers were welded by the action of explosives. In these investigations we were concerned with the production of profiled hollow bodies which can be produced with relatively small degree of complexity and with good reproducibility because of the further advantage in the technology of semifinished product production. In contrast to this, earlier authors carried out fundamental research in this area.

2. METHODS OF EXPLOSIVE WELDING

The distance between the two metal plates which are to be welded using explosive welding techniques is one characteristic parameter. When the explosive is detonated on one plate, it is accelerated towards the other plate and reaches it with a high velocity. This collision velocity is required in order to introduce processes which occur during the explosive welding process, such as tearing of the surface layer, wave formation, etc [6]. During the production of fiber composite materials by explosive welding, it is also necessary that the metal foils have an exactly defined distance from each other. This distance is prescribed by the fiber diameter, and fortunately by modifying the explosive charge thickness and composition, it is possible to obtain perfect welding results over a large range of fiber diameters and foil thicknesses. This means that almost any desired fiber volume fraction can be realized.

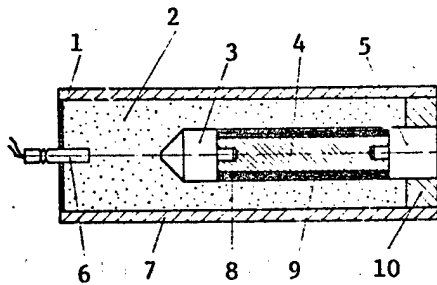

Figure 1. Configuration for explosive welding of fiber reinforced hollow bodies.

1- cardboard disk; 2- explosive;
 3- head; 4- core; 5- tear away
 plug; 6- igniter capsule;
 7- plastic tube; 8- covering
 tube; 9- foil plus fibers;
 10- plastic material disk.

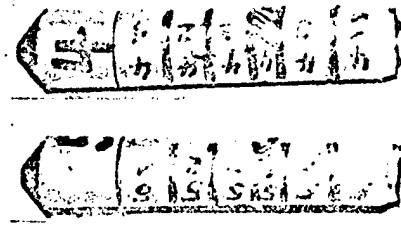

Figure 2. Bombarded fiber reinforced hollow bodies.

Figure 1 shows the structure of a laboratory configuration for a hollow cylinder which is fiber-reinforced in the axis direction. The matrix foil with the fibers attached to it is wound in several layers around a cylindrical core, and an alternating configuration of fiber layers and foil layers occurs. The cross-sectional shape of the core determines the later cross-sectional form of the fiber-reinforced hollow body, and has a metallic covering tube which is placed over the winding body. The winding body is closed at both ends with plugs, so that the detonating explosive will not tear up the winding. The body prepared in this way is concentrically secured with a plastic tube and the slit surrounding it is filled with explosives. It is ignited on the end while hanging over a sand pit. As a rule these bodies can again be found after explosion. The temperature of the parts (Figure 2) ranges from hand temperature up to about 150° C and depends essentially on the fiber volume fraction, i.e.,

on the plastic work of deformation which the matrix must absorb. The air between the fibers and the foils is pressed downwards for the ring-shaped detonation progressing in the axial body direction. Of course, it also heats up adiabatically or gives part of its considerable heat to the body, so that the body has a heat profile which increases in the direction of detonation. For very high fiber volume fractions (> about 50%) it can become necessary to detonate the parts in a vacuum for certain fiber/matrix combinations.

The removing of the cores and the covering tubes of course represents undesirable additional work, which can be avoided by covering the core with a plastic layer (shrinkable tubing) and instead of the metallic covering tube, one winds a self-adhesive aluminum foil around the body in several layers. The foil then explodes during the detonation and the body is displaced partially or even completely away from the core covered with plastic, which then can be completely removed. However, no additional work is required on the composite body.

/288

3. PROCESSES DURING THE EXPLOSIVE WELDING PROCESS

During the detonation of the explosive, pressures up to 200,000 bar act on the metal foils to be welded to one another. In this way, because of the high deformation velocity, the flowing materials show a behavior which can be described using the laws of hydrodynamics, i.e., the materials can be considered as liquids having greater or smaller viscosity. Figure 3 gives a clear example of this, and shows a V2A fiber welded into a nickel foil. Because of the oblique position with respect to the direction of detonation, the incident matrix metal flow was oblique with respect to its axis and it therefore approximately deformed into a Joukowski profile.

--	--	--	--	--	--	--	--

If the fibers are stretched tightly between the foils and if the detonation wave runs in the axial direction, then if the explosive is correctly selected and for a correspondingly increased ratio of fiber hardness to matrix hardness, one obtains an exceptional welded composite body (Figure 4). The matrix material squeezed between the fibers takes on the profile of a laminar flow. Since the fibers are pressed into the foil below at the same time, the material of this foil flows upward with the same flow profile. The two profiles meet at the height of the fiber center at a point, if we consider a planar model, from which point the welding between the foils progresses in a direction oblique with respect to the fibers (Figure 5).

4. ATTACHMENT OF FIBERS ON THE FOILS

It was shown that a tight stretching of the fibers in the winding body was one prerequisite for the production of a perfect composite body. For this purpose, the fibers must have a certain prestress when they are attached to the foils, and many methods can be used.

One method with a low degree of complexity consists of winding around a foil strip which is stretched tightly between the headstock and and chuck of a winding machine (Figure 6). The beginning and ending of the wire are directed through small holes at the edges of the strip and are knotted there. This foil strip covered with fiber is wound around a prismatic core together with a strip with no fibers, so that an alternate layering of foil and fiber layers is produced. The method, however, has the disadvantage that, if relatively soft matrix metals are used, the foil edges will bend because of the fiber tension, so that the fiber stress becomes variable over the foil strip length when the foil is stretched later on. The method is therefore only suitable for relatively stiff matrix materials and relatively



Figure 3. Deformation of a V2A fiber in a Ni matrix into approximately a Joukowski profile.

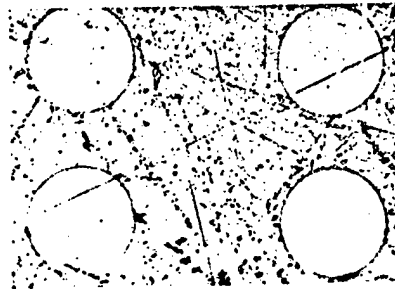

Figure 4. Welded composite material free of defects (fiber: tungsten 0.1 mm; matrix: niobium 0.1 mm).

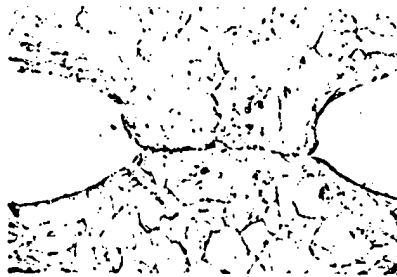

Figure 5. Welding of matrix foils with collision point located at the center between the fibers (fiber: V2A 0.1 mm; matrix: nickel 0.1 mm)

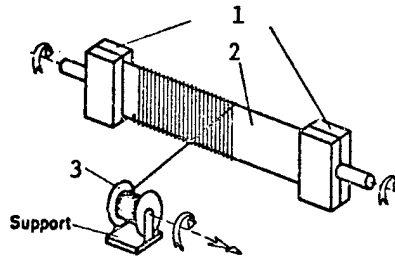

Figure 6. Covering of foil by layers using winding.

1- clamping heads; 2- sheet strips; 3- fiber coil;

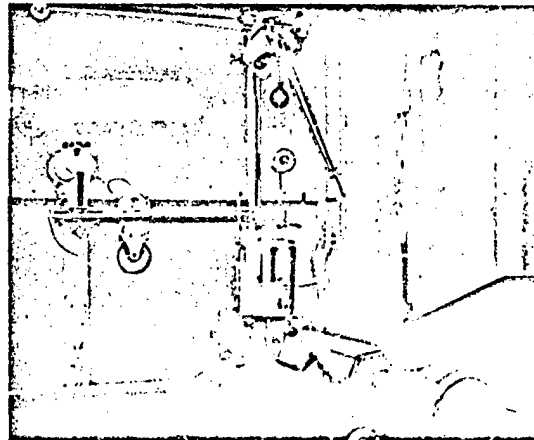

Figure 7. Configuration for winding the auxiliary cylinder with fibers.

small fiber volume fractions.

The second method for attaching the fibers to the foils uses an auxiliary cylinder with a multicorner cross section, and the foil strips are mounted on to its side so that they can be removed. This auxiliary cylinder is now clamped in the same winding machine (lathe) and fibers are wound on it. The fiber volume fraction desired for the fiber composite material is produced, on the one hand, by the fiber diameter to foil thickness ratio and also by the machine advance within wide limits. The prestress with which the fibers are wound on the auxiliary cylinder depends on the materials used as well as on the foil and wire thicknesses. The uniformity of the stress is provided by a special thread stand with a control device for the thread stress (Figure 7).

/ 289

The following methods have proven themselves for attaching the fibers at the edges of the foil.

4.1. Gluing of the fibers

The fibers are attached to the foil edges with an adhesive layer about 5 mm wide and the metal adhesive can be applied either before or after the winding process by means of a roller (Figure 8). There is no welding between the metal foils at the points with adhesive. However, we were not able to detect any extensive prevention of welding, for example, by vaporized adhesive. The adhesive can only have a detrimental effect if it partially covers the fibers with a thin layer. During rolling up of the foils on the cores, this leads to thickening at the ends of the winding body. Therefore, it is often difficult to maintain the maximum foil separation specified by the fiber diameter. Since the experiment was always adjusted to a foil separation corresponding to the fiber diameter, a greater separation leads to melting

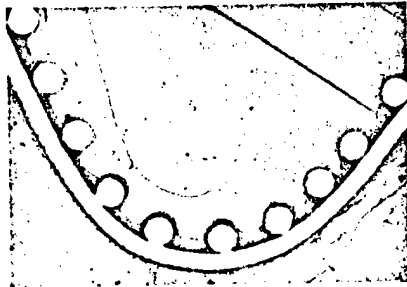

Figure 8. Fibers glued on to foil in a cross section (fiber: V2A 0.1 mm; foil: nickel: 0.05 mm).

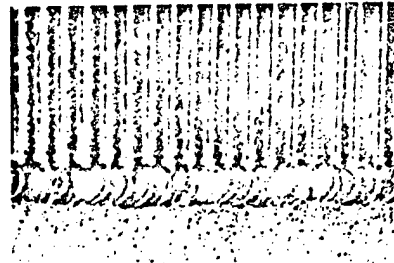

Figure 9. V2A fibers (0.1 mm) welded to a nickel foil (0.1 mm) using an electron beam.

/ 289



Figure 10. Longitudinal section through the electron beam welding of Figure 9.



Figure 11. Roller welding of molybdenum fibers (0.1 mm) on nickel foil (0.05 mm).



Figure 12. Longitudinal section through roller welding of Figure 11.

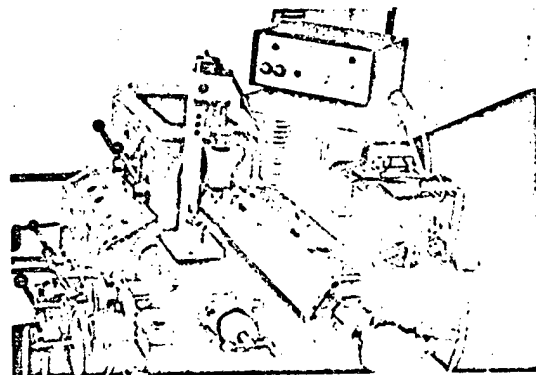

Figure 13. Configuration for roller seam welding of the fiber/foil semifinished product.

--	--	--	--	--	--	--	--

because of the then considerably increased contact velocity between the foils, which can make the composite material useless.

4.2. Welding of fibers with the electron beam

Figures 9 and 10 show an example of an electron beam weld between stainless steel fibers and a nickel foil (or welding of stainless steel fibers to a titanium foil). This shows that exceptional results can be achieved with this process. The great complexity of this method means that the semifinished products cannot be produced using this method economically in the near future.

One positive feature of electron beam welding is the fact that it is possible to weld a wide range of fiber and matrix materials with different diameters and thicknesses, without changing the machine adjustment substantially. In no case did we observe drop formation at the welding points so that when the winding bodies are produced, we no longer have the disturbing thickened parts along the face sides of this body. Strength measurements at the welding points in the fiber direction showed that the fibers can accept a multiple of the required prestress force, even though in general brittle intermetallic compounds are formed in the welding zone.

4.3. Welding of fibers with the welding roller

The method showed exceptional results just like the electron beam welding method. However, it has the distinct advantage that it can be automated to a high degree and can be implemented with a low degree of complexity. Such welds between molybdenum fibers and nickel foil is shown in Figure 11. Figure 12 shows a longitudinal section through the welding point for this combination of materials. Here again the strength of the weld in the fiber

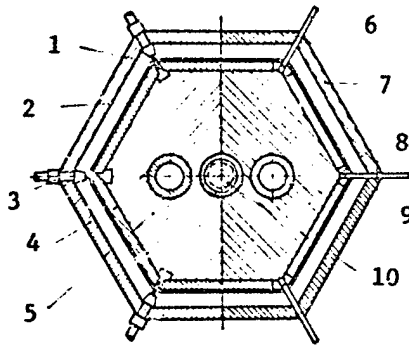

Figure 14. Possibilities for separating the fiber winding at the edges of the auxiliary cylinder.

- 1- fiber winding; 2- foil;
- 3- oxyhydrogen gas burner;
- 4- copper plate; 5- core;
- 6- knife roller; 7- frame;
- 8- knife bar; 9- guide jack;
- 10- transport spindle.

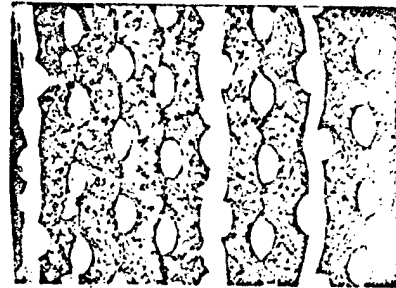

Figure 15. V2A tissue (wire thickness 0.1 mm) reinforced nickel matrix (0.1 mm).

direction is a multiple of the strength required for absorbing the fiber prestress, and there is a small amount of scatter in the strength values.

A transformer, a control unit and a spring-suspended welding roller are required for the process. The welding head was attached to the support of a lathe (Figure 13) during the experiment and it was possible to use its automatic advance so as to regulate the welding velocity, which is on the order of 10 mm/sec. The current supply through the auxiliary cylinder made of copper plates was through both face sides of the cylinder in order to reduce the voltage drop during the welding process.

--	--	--	--	--	--	--	--	--

5. FURTHER PROCESSING OF THE SEMIFINISHED PRODUCT

The following discussion is limited to the semifinished product obtained using the winding method with the auxiliary cylinder and by welding the fibers with the welding roiler, because these methods have special importance compared with the other methodsdiscussed before.

In order to remove the foils attached to the auxiliary cylinder and the welded fibers, it is necessary to separate the fibers at the edges of the auxiliary cylinder. For this purpose, the cylinder has longitudinal grooves at the edges, so that two technical-economical methods can be used for separating the fibers (Figure 14).

The natural method is to cut through or shear off fibers at the sharp and hard edges of the grooves with a knife roller. The second method consists of burning through the fibers using a oxyhydrogen gas burner, which can be used to easily separate the fiber materials with a high melting point, such as, for example, tungsten. In both methods it is possible to separate the fibers at all edges of the auxiliary cylinders, by arranging the separation devices in a special device, in which the cylinders are transported by means of threaded spindles or similar devices.

One can easily imagine a combination of the welding and separation processes for automatic production, if the welding rollers are arranged ahead of the separation elements in such a device. However, a separate current supply would have to be provided for each welding roller in order to provide for uniform supply of all the welding rollers with a current of equal intensity. Immediately after welding the fibers to the foils, it would be possible to separate the fibers by the subsequent knife-roller or burner along the edges of the auxiliary cylinder.

--	--	--	--	--	--	--	--	--	--

This would mean that the foil strips covered with the fibers could then be removed for further processing from the auxiliary cylinder.

The further processing of the semifinished product is done by winding a core with this foil or by applying layers, depending on whether we have a hollowed body or a flat body. In both cases one must make sure that a very dense packing is brought about.

When producing flat fiber reinforced plates, one side of the layer is covered with explosives after it has been covered, for example, by self-adhesive metal foils and is therefore protected against combustion products of the detonating explosive. Such a layering requires a small degree of effort when using metallic tissue. In this way, a body is produced which is reinforced in two directions (Figure 15) and its tensile strength in the fiber direction is considerably lower than for a body reinforced in a unidirectional direction with a comparable fiber volume fraction, because of the crossing points with the fibers which run transversely.

The purpose of this work was to produce fiber-reinforced hollow bodies with a profiled cross section. We proceeded by winding the core, corresponding to the cross-sectional profile being produced, with the foil covered with the fibers. The fibers run in the axial direction which at the same time is also the direction of detonation. It has been found that it is useful to apply a plastic layer (shrinking tubing) to the core so that, after bombardment, it can more easily be removed from the hollow body. The end of the winding is prevented from coming apart by means of an adhesive foil and the winding body is surrounded with a metallic covering, in order to protect it against detonation products. Instead of the massive metal covering, it is also possible to wind on a self-adhesive metal form in several layers on to the body. It explodes during

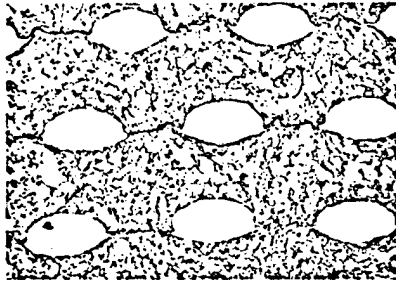

Figure 16. Explosively welded composite material of Ni foil (0.1 mm) with V2A fibers (0.05 mm).

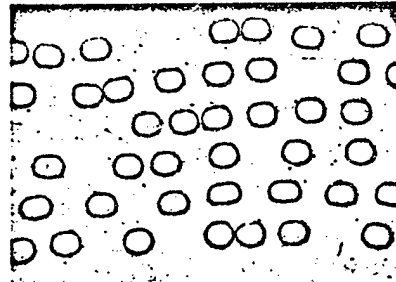

Figure 17. Explosively welded composite of V2A foil (0.1 mm) with tungsten fibers (0.1 mm).

/291

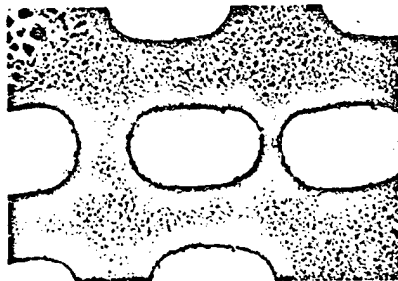

Figure 18. Explosively welded composite of spring steel foil (0.09 mm) with tungsten fibers (0.1 mm).

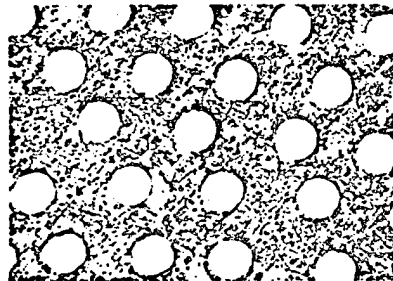

Figure 19. Explosively welded composite of titanium foil (0.1 mm) with tungsten fibers (0.1 mm).

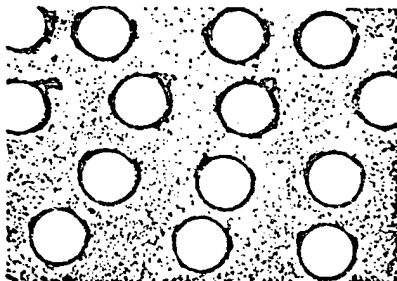

Figure 20. Explosively welded composite of zirconium foil (0.1 mm) with tungsten fibers (0.1 mm).

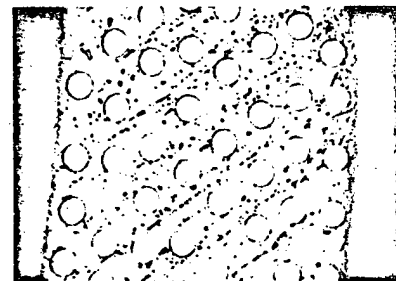

Figure 21. Explosively welded composite of niobium foil (0.1 mm) with tungsten fibers (0.1 mm).

detonation, so that it is no longer necessary to dig the core and the surrounding tube out after detonation. The winding body is closed off along both faces with metal or plastic plugs, so that no explosive can reach the layers to be welded. The laboratory configuration is the one described in Section 2.

6. FIBER COMPOSITE MATERIALS WHICH CAN BE PRODUCED BY EXPLOSIVE WELDING

Almost all metallic fiber/matrix combinations can be produced using the explosive welding technique, if these materials have a certain minimum amount of ductility. Because of the nature of fiber reinforcement, the fibers are usually much harder than the matrix materials used, so that fiber deformation must usually be limited. The E modulus ratios, the heat expansion ratios and the chemical compatibility of the components do not have a direct influence on the effectiveness of the explosive welding process. They only become important according to the applications, for example, if a high temperature load is required of the composite material.

Figures 16 to 22 show cross sections of successfully welded composite materials. The limits for the maximum possible fiber volume fractions are not specified by the method, but by the geometric conditions and the minimum distances between fibers determined for physical reasons, which can be assumed to lie between 5 and 10 μm . Figure 23 also shows that the matrix material can flow into very narrow cracks when the explosive welding technique is used. The smallest crack filled by the titanium matrix is about 3 μm here.

The imbedding of brittle fiber metals such as, for example, beryllium (Figure 24) causes difficulties, which usually fractures even if soft matrix metals are used such as aluminum.

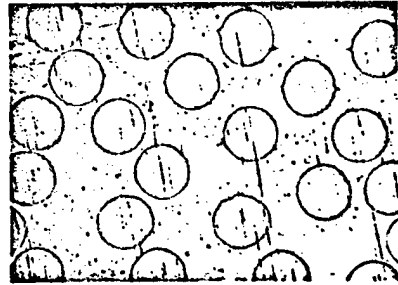

Figure 22. Explosively welded composite of inconel-718 foil (0.053 mm) with tungsten fibers (0.1 mm).

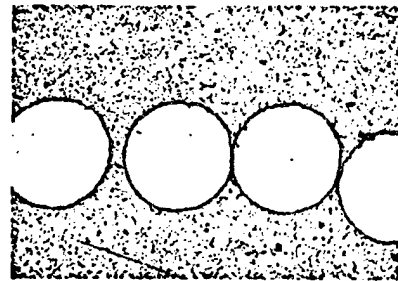

Figure 23. The matrix metal flows in even the smallest spaces between fibers during explosive welding.



Figure 24. Explosively imbedded beryllium fiber (0.1 mm) between nickel foils.

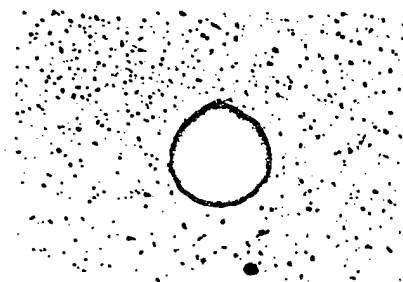

Figure 25. Explosively imbedded ceramic fiber (Tyco 0.3 mm) between niobium sheets.

/292

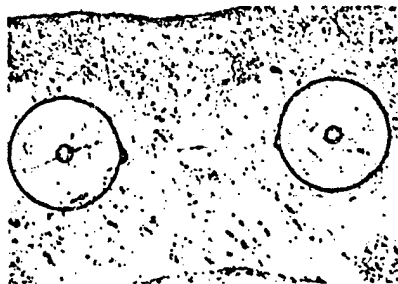

Figure 26. Explosively imbedded boron fibers (0.1 mm) between nickel foils.



Figure 27. Explosively imbedded carbon fibers (5 μ m) between nickel foil.

The imbedding of ceramic fibers (Figure 25), boron fibers (Figure 26) and carbon fibers (Figure 27) without destruction is even more difficult and sometimes impossible. As a rule, these fibers break up into short pieces unless they are completely compressed.

7. PROPERTIES OF EXPLOSIVELY WELDED FIBER COMPOSITE MATERIALS

There is a true welding between the matrix foils during the explosive welding of fiber composite materials. One condition for this is that the foils have a separation which makes it possible to accelerate them to the required collision velocity. At the collision point a beam of matter is formed which consists of particles of both foil surfaces, and which flies away in the direction of detonation [6]. The metal surfaces which have become blank weld together under the effects of the detonation pressure. At the present time we were not yet able to prove to what extent this is also true for the boundary between the fiber and the foils. However, it is certain that even the microscopically smallest surface roughnesses are filled with matrix metal (see Figure 23), so that an extremely intensive mechanical clamping between the fibers and the matrix is brought about, even though this is usually not a true metallurgical bond. However, a diffusion barrier remains intact which later on has a positive effect for high temperature operation.

The appearance of the fracture surfaces gives an indication on the quality of the bond. If the fibers tear at the fracture surface of the matrix without standing out (Figure 28), we can conclude that we have a very good bond.

The tensile strength in the fiber direction measured on the bodies shown here usually amounted to between 80 and 100% of the tensile strength determined according to the mixing rule.

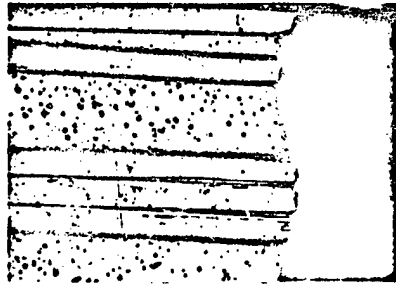

Figure 28. Longitudinal section through a tearing sample made of Inconel 718 with tungsten fibers (0.1 mm).

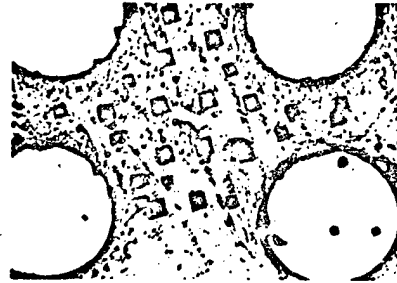

Figure 29. Strengthening of a titanium matrix by plastic deformation during explosive welding.

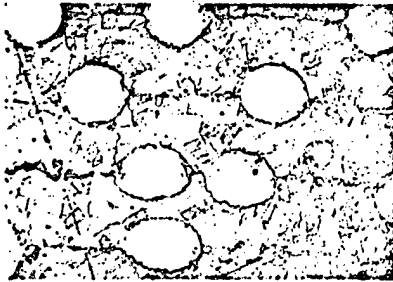

Figure 30. Nickel matrix with V2A fibers, annealed for 9 hrs. at 800° C.

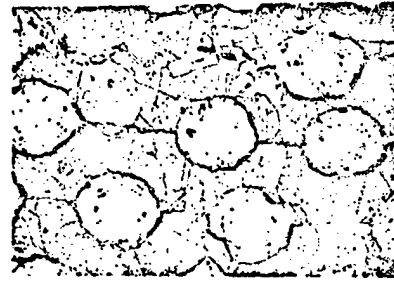

Figure 31. Nickel matrix with V2A fibers, annealed 96 hrs. at 800° C.

/ 293

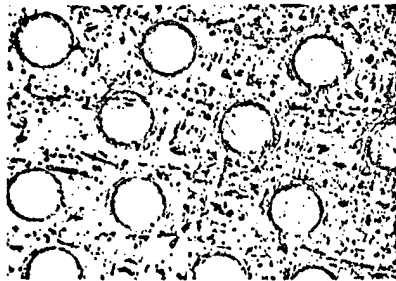

Figure 32. Niobium matrix with tungsten fibers, annealed for 96 hrs. at 1100° C.

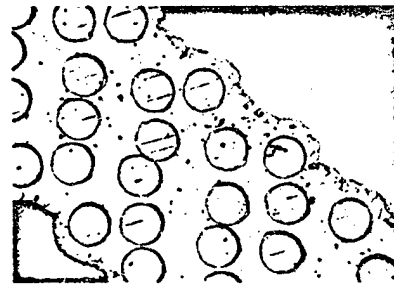

Figure 33. Inconel-718 matrix with tungsten fibers, annealed 96 hrs. at 1100° C.

For the composite material shown in Figure 28, tungsten fibers and an Inconel-718 matrix with a fiber volume fraction of 28%, we measured a tensile strength of 101 kp/mm², for example, on the average, and the calculated tensile strength is 116 kp/mm².

When the fibers are surrounded with a material, the matrix is deformed in a cold state, which in some matrix materials brings about a strong strengthening (Figure 29). In this way the strength of the matrix is increased and often a higher tensile strength is determined than was predicted by the calculation. Explosive welding as a method for producing fiber composite materials is suitable most of all for composite materials with a high degree of temperature resistance. Therefore, in particular we are interested in the compatibility of the components at temperatures to which the materials could be subjected depending on the applications. Figures 30 to 33 show a few results of annealing experiments with various material combinations. In the case of a combination of V2A fibers and a nickel matrix, we find after a 96-hour annealing at 800° C that there is a strong diffusion between the fibers and the matrix (Figure 31); the composite has already been extensively damaged. A niobium matrix with tungsten fibers after 96 hours of annealing at 1100° C (Figure 32) also reacts strongly. The technically very interesting combination of tungsten/inconel-718 after 96 hours of annealing at 1100° C shows only a very narrow diffusion zone (Figure 33) even though these fibers do not have any alloy additives which would lead one to expect a considerable improvement in the compatibility.

8. FORMING POSSIBILITIES AND APPLICATIONS

Hollow bodies of widely varying cross sections can be produced using the winding techniques discussed. If the core has the proper shape, it is not necessary to post-form the

/293

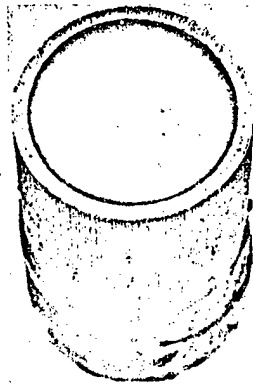

Figure 34. Explosively welded fiber reinforced hollow cylinder (fiber: tungsten 0.1 mm; matrix: zirconium 0.1 mm; fiber volume fraction 24%).



Figure 35. Explosively welded fiber reinforced hollow body with blade cross section. (fiber: tungsten 0.1 mm; matrix: inconel 718 0.08 mm).

cross-sectional shapes, so that hollow bodies produced in this way practically do not have to be machined. Figure 34 shows a fiber-reinforced hollow cylinder with a diameter of 17 mm and a length of 60 mm produced according to this method.

The hollow body with the blade cross section shown in Figure 35 was also produced using this method and no additional complexity was involved. Blade profiles with a concave underside are also possible. By further refinement of this technique one could certainly imagine that it would be possible to weld in ribs into the hollow body during the welding of the foil winding. On the other hand, the installation and forming of the blade foot with additional stiffening elements will require one of several more working processes. From the point of view of the technology of today, it will be possible to produce fiber reinforced turbine blades up to a length of about 150 mm using the explosive welding technique, and even relatively flat profiles can be produced. If it becomes possible to improve the compatibility of the fiber and matrix materials further, and to develop usable

protective layers for blades against corrosion and erosion, then explosive welding can contribute to the building of turbine blades which can withstand temperatures of 1100° C and more, such as are required at the high rpms of today.

REFERENCES

1. Jarvis, C. V. and P.M.B. Slate. Explosive Fabrication of Composite Materials. Nature, Vol. 220, No. 5169, 23. 11. 68, pp. 782-783.
2. Fleck, J. N., D. Laber and R. W. Leonard. Explosive Welding of Composite Materials. J. of Composite Materials, Vol. 3, October 69, pp. 699 - 701.
3. Reece, O. Y. Explosive Bonding Packs Strength into Metal Composites. Iron Age, Vol. 29, 29. 1.70, pp. 60-61.
4. Fleck, J. N. Non-conventional Fabrication of Metal-Matrix Composites. ASME Internat. Engineering Conf. and Tool Exposition, Detroit, 13.-17.4.70, Paper EM 70-125.
5. Wolff, E. Production of Thermally and Mechanically Highly Loaded Components, especially Turbomachine Blades made of Fiber-Reinforced Metals, using the Explosion Forming Technique. German Patent Application, No. 2055637, 12. 11.70.
6. Crossland, B. The Development of Explosive Welding and Its Applications in Engineering. Metals and Materials, Dec. 71, pp. 401-413.