



A Study of the Mechanical Behavior
of OFHC Copper in Tension at Various
Strain Rates and Heating Rates Using the
Two-Dimensional Integrated Speckle
Measuring System

by Brian G. Durant
and Nathaniel D. Bruchey

ARL-TR-2248

June 2000

Approved for public release; distribution is unlimited.

DTIC QUALITY INSPECTED 4

20000719 019

The findings in this report are not to be construed as an official Department of the Army position unless so designated by other authorized documents.

Citation of manufacturer's or trade names does not constitute an official endorsement or approval of the use thereof.

Destroy this report when it is no longer needed. Do not return it to the originator.

Army Research Laboratory

Aberdeen Proving Ground, MD 21005-5066

ARL-TR-2248

June 2000

A Study of the Mechanical Behavior of OFHC Copper in Tension at Various Strain Rates and Heating Rates Using the Two-Dimensional Integrated Speckle Measuring System

Brian G. Durant

Weapons and Materials Research Directorate, ARL

Nathaniel D. Bruchey

Dynamic Science Inc.

Abstract

The objective was to investigate the mechanical behavior of oxygen-free high-conductivity (OFHC) copper in tension. A modified dog bone specimen was heated using resistive heating techniques. The effects of high temperature, medium strain rates, and high heating rates on the stress-strain results were observed. A new two-dimensional (2-D) integrated speckle measuring system and a high-speed optical pyrometer were utilized for strain and temperature measurements. Room temperature tests were conducted at strain rates of quasi-static and 1/s. The high heating rate experiments were conducted at temperatures of 360° C and 375° C, heating rates of 30° C/s and 263° C/s, and at a strain rate of 1/s. A nominal decrease in the elastic modulus and an increase in the elastic limit are seen for increasing strain rate. Decreases in yield stress and flow stress were observed as the heating rate was increased.

Acknowledgments

The authors would like to thank Dr. Martin Raftenburg, Dr. Michael Staker, and Mr. Dennis Pritchard for their valuable technical discussions. The authors also thank Mr. Jack Mullin for making the optical micrographs.

INTENTIONALLY LEFT BLANK.

Table of Contents

	<u>Page</u>
Acknowledgments	iii
List of Figures	vii
List of Tables	ix
1. Introduction	1
2. Background	2
2.1 Digital Image Correlation Software	2
2.2 Digital Image Correlation Hardware	5
2.3 The Medium Strain Rate Machine (MSRM) Test Facility	6
3. Experimental Procedure	7
3.1 Material and Specimen Geometry	7
3.2 Dynamic Deformation	8
3.3 Dynamic Deformation of OFHC Copper at High Heating Rates	10
4. Discussion of Experimental Results	11
4.1 Effects of Strain Rate	11
4.2 Effects of Heating Rate	13
5. Summary and Conclusions	17
6. References	19
Distribution List	21
Report Documentation Page	25

INTENTIONALLY LEFT BLANK.

List of Figures

<u>Figure</u>		<u>Page</u>
1.	Sample Images of OFHC Copper Specimens Obtained With a Kodak Digital Camera	3
2.	Displacement vs. Position for a Strain of 5.1%	5
3.	Specimen Geometry	7
4.	Block Diagram of a Mechanical Test System	9
5.	Block Diagram of a High Heating Rate Test System	10
6.	Calibration Curve of Vanzetti Optical Pyrometer	11
7.	Stress-Strain Curve for Quasi-Static Tests of OFHC Copper	13
8.	Comparison of Stress-Strain Curves of OFHC Copper for Average Strain in Quasi-Static Test and Average and Necking Region Strains in 1/s Tests.....	13
9.	Effects of Heating Rate and Temperature on OFHC Copper Properties	14
10.	Optical Micrographs of OFHC Copper: (a) Initial OFHC Copper Specimen From Bar Stock; (b) Tensile Loaded at a Strain Rate of 1/s; (c) Heated to 360° C/s at a Heating Rate of 30° C/s, Then Tensile Loaded at a Strain Rate of 1/s; and (d) Heated to 375° C/s at a Heating Rate of 263° C/s, Then Tensile Loaded at a Strain Rate of 1/s.....	15

INTENTIONALLY LEFT BLANK.

List of Tables

<u>Table</u>		<u>Page</u>
1.	Mechanical and Physical Properties of OFHC Copper (Cu99.95Min).....	8
2.	Mechanical Properties of OFHC Copper at Various Strain Rates and Heating Rates.....	12

INTENTIONALLY LEFT BLANK.

1. Introduction

The primary objective of this work was to accurately measure the mechanical behavior of oxygen-free high-conductivity (OFHC) copper in tension under different strain rates and heating rates. To aid in this measurement, a new two-dimensional (2-D) integrated speckle measuring system was developed to obtain point and full-field displacement measurements and to extract Poisson's ratio and other deformation data. The 2-D integrated speckle measuring system is nondestructive and allows remote sensing at room and elevated temperatures and can measure strains of up to 25%. The basic principle for measuring deformations on the surface of the specimen with the 2-D integrated speckle measuring system involves correlating speckle images before and after deformation. Additional speckle images can be obtained at different stages of deformation, and successive pairs of images are captured by a charge coupled device (CCD) camera, stored on a frame grabber board, and then downloaded to a personal computer (PC). The system then uses a digital image correlation algorithm to determine the displacement and strain between images.

The motivation behind using the 2-D integrated speckle system is to obtain full-field deformation data at room temperature and at high heating rates that include the necking region of the specimen. This method is superior to the traditional strain gage, which gives only an average value under the area of the gage and does not hold up well at high temperatures. Moreover, aligning the 2-D integrated speckle system is easy and straightforward and eliminates the cumbersome procedure of aligning the strain gage parallel to the loading axis.

In the armor penetration process, all materials experience rapid heating, high temperatures, and triaxial stress states [1]. Researchers have determined that varying the strain rate and heating rate can alter the stress-strain relationship of the material [1]. Controlled laboratory experiments are required to determine the material properties under these varying conditions and to provide material constants used in computer simulations and material modeling. OFHC copper was chosen particularly because of its use as an antiarmor material in shape charge liners where the liner undergoes rapid deformation, high heating rates, and high temperatures. Measuring the

mechanical properties of OFHC copper under different heating rates and temperatures has received very little attention in the past. Preliminary results show that microbands, regions of high strain concentrations, tend to form in OFHC copper at high temperatures [2]. These microbands may act as a precursor to material failure. This work represents an investigation into the effects of different strain rates and heating rates on the mechanical properties of OFHC copper.

2. Background

In the testing of OFHC copper, high heating rates, high temperatures, and the desire to examine full-field strain behavior led to the development of a new strain measuring system. The system is based on the theory of digital image correlation of white-light speckle patterns. The OFHC copper testing employed the previously proven concept with a new system specifically designed to efficiently yield full-field, noncontact stress-strain measurements [3].

Digital image correlation provides noncontact, 2-D displacement measurement [3, 4]. Because the theoretical basis had already been examined, the OFHC copper testing concentrated on developing practical application procedures of the theory to use in dynamic testing. As a result, the background given will be more application-oriented, with less detail devoted to the theoretical basis. To enable correlation, a speckle pattern was created on the specimen surface. The pattern was generated using a high-temperature (up to 650° C) spray paint. To obtain the high contrast needed for the correlation technique, white and black spray paints were used. The specimen was first uniformly coated with white paint, then a fine mist of black paint was used to create a random pattern of black dots. Sample images are shown in Figure 1.

2.1 Digital Image Correlation Software. Images such as those in Figure 1, captured by a CCD camera as the specimen was deformed, were analyzed using the correlation software. The specimen appears horizontal due to the 90° rotation of the CCD camera. The circle shows a speckle as it is displaced from left to right during a tension test. The displacement between

necking

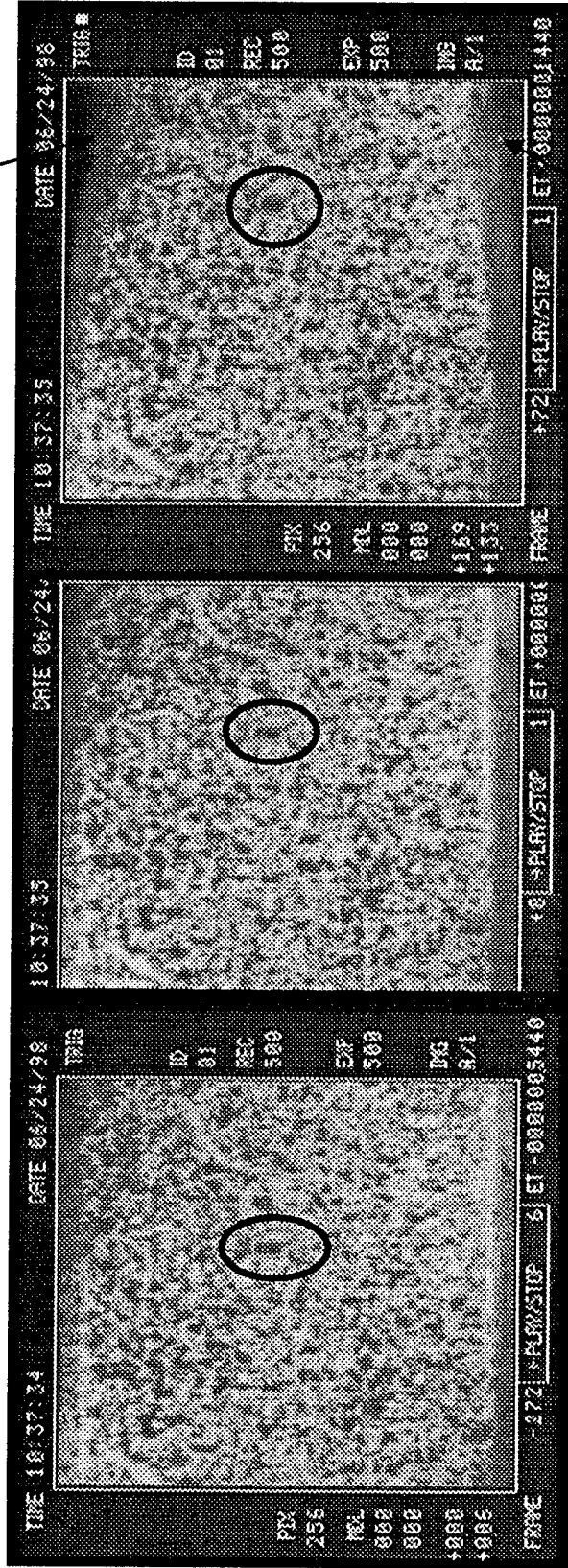

1. Initial Image

2. Uniform Elongation

3. After Necking

Figure 1. Sample Images of OFHC Copper Specimens Obtained With a Kodak Digital Camera.

image 1 and image 2 is 5.6 mm (15 pixels); between image 2 and image 3, the displacement is 8.5 mm (23 pixels); and between image 1 and image 3, the displacement is 14.1 mm (38 pixels). The process of digital image correlation can be referred to as smart imaging. The system compares an initial, undeformed image with subsequent images of the deformed specimen. For example, both the second and third images shown in Figure 1 would be compared to the initial image. Depending on the approach taken, the computer uses correlation functions, mathematical comparators, and fourier transforms to look at the two images. In essence, the computer attempts to fit the unstrained image to the strained image, knowing that the differences are caused by deformation. Think of the initial image as a piece of rubber. Using correlation functions, the computer mathematically stretches the rubber to fit the new deformed pattern of the second image. The software can take two images that look the same to the human eye and recognize unique patterns that enable it to calculate displacements. Similarly, using mathematical comparators, it can take two images that look different, and by knowing that the differences are caused by deformations, extract that data by making the images identical.

Either the complete image (shown in Figure 1) or a desired portion of the complete image was chosen for analysis. The desired portion was analyzed in steps by breaking it into small subimages of 31×31 pixels (132 mm^2) with a step of 15 pixels between adjacent images. For example, the second subimage would include about half the area of the first subimage. The subimage size and the steps between centers of subimages can be selected by the user from a pull-down menu. The smaller the subimage size, the more resolution that could be obtained in the strain field, but the larger the amount of noise in the results. Each of the subimages was analyzed with the corresponding subimage from a previous deformation state. The comparison was performed mathematically by the software. A preload of 267 N was applied to each specimen to eliminate any shifting in the grips that might occur during the initial loading of the specimen. The result of the analysis of each subimage was the average displacement of the pixels within that subimage. This value was associated with the position at the center of the subimage. The displacement field for the chosen area was determined by analyzing all the subimages within that area; a full tension test was analyzed by examining all images captured by the high-speed CCD camera.

Although the digital image correlation theory can be used to produce 2-D displacement or strain fields, for OFHC copper testing only, the average strain along an axial line was examined. For each time-step image analyzed, the results of the displacement of each subimage vs. the position of that subimage were plotted, as shown in Figure 2. Average strains were calculated using a linear fit to the displacement data, the slope of which represents the strain. The effects of this procedure have been studied and shown to help improve the accuracy of the strain determination [3, 5]. Data scatter in these graphs of displacement vs. position decreased as strain increased. The correlation system was able to measure strains as small as 0.01% and as large as 25%. For strains smaller than 0.01%, the signal-to-noise ratio is poor. For strains larger than 25%, the speckle image often falls off the viewing area. The digital image correlation software cannot correlate speckle images off the viewing area. One solution to this problem would be to use a CCD camera with a viewing area larger than 192 pixels \times 238 pixels.

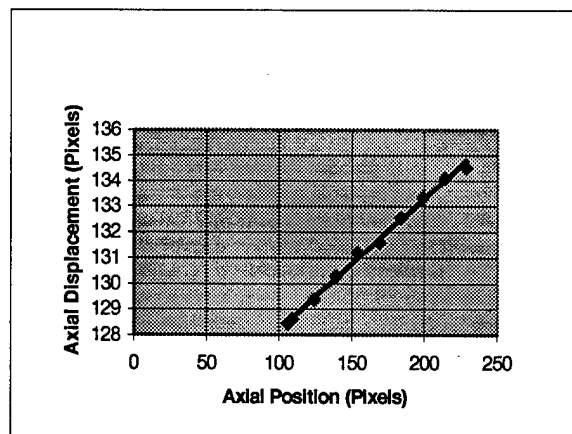

Figure 2. Displacement vs. Position for a Strain of 5.1%.

2.2 Digital Image Correlation Hardware. The imaging and analysis system consisted of a high-speed CCD camera and a 100-MHz Pentium PC. Images were recorded using a Kodak Ektapro EM motion analysis system that included a high-speed CCD camera and a digital processor. Framing rates of up to 1,000 frames/s were possible for full-screen images. Additionally, the processor allowed the frame to be split into various amounts (half, thirds,

fourths, sixths, and twelfths), which enabled framing rates up to 12,000 frames/s with 1/12 full-screen images. Similarly, exposure times ranged from 1/50 of a second to 1/12,000 of a second, depending on image split and recording rate. To obtain load and temperature data, the signals from the load cell and pyrometer were fed into a Kodak multichannel data link. The output of the multichannel data link was connected to the motion analyzer and viewed on a Sony Trinitron monitor. The monitor was, in turn, connected to a PC via an RS-170 cable.

The digital images were obtained using a 200-mm lens. The physical size of the CCD array was 192 vertical \times 238 horizontal pixels. The PC captured the image with a Picture Perfect frame grabber board and digitized it with accompanying Picture Perfect software. Typical image sizes were approximately 300 vertical pixels \times 342 horizontal pixels (108 mm \times 127 mm), which gave a resolution of 2.76 pixels/mm in the vertical direction and 2.69 pixels/mm in the horizontal direction. Although there was not a one-to-one correspondence between the size of the digital image and the size of the CCD array, this would not affect correlation results [3]. Digital image correlation software was used to analyze the images. The image correlation data was then imported into Excel and Mathcad and further processed to produce stress-strain curves for the OFHC copper.

2.3 The Medium Strain Rate Machine (MSRM) Test Facility. The medium strain rate test facility of the Impact Physics Branch consists of a Terra Tek MSRM, a variac/transformer heating system, an intensifier for high-pressure tests, and a PC used to control the test operation. The MSRM is specifically fitted with special tension grips to allow the output of the transformer to be attached to the specimen via high current cables. The heating apparatus utilizes resistance heating where, using the variac/transformer, current is passed through the specimen and the specimen's own resistance produces joule heating. Heating rates as low as 20° C/s and as high as 1,000° C/s are achievable. The MSRM is capable of loads up to 140,000 lb at strain rates of 0.0001/s–100/s. Two modes of operation are possible: an open loop mode where nitrogen gas is expelled through fast-acting valves for strain rates of 1/s–100/s and a closed loop hydraulic servo-controlled mode for strain rates of less than 1/s. The feedback element in the closed loop mode can consist of either a load, strain gage, or LVDT signal. In a

typical test, the feedback signal is compared to a user selected setpoint signal, and the piston moves in a direction to make the algebraic difference of these two signal zero. In a tension test, the feedback signal is less than the setpoint signal, thus moving the piston in a vertical (tensile) direction.

3. Experimental Procedure

3.1 Material and Specimen Geometry. The material used in this study was cylindrical OFHC copper specimens 63.5-mm long and 6.35-mm wide, as shown in Figure 3. The physical and mechanical properties are listed in Table 1 [6]. The specimens were cleaned with a degreaser, then with an acid-base combination to remove all remaining residue. The gage area was then randomly roughed with 120-grit SiC sandpaper and cleaned once again. Speckle patterns were generated on the specimen using black and white spray paints. The specimens were then placed in the MSRM and illuminated with incoherent white light in preparation for testing.

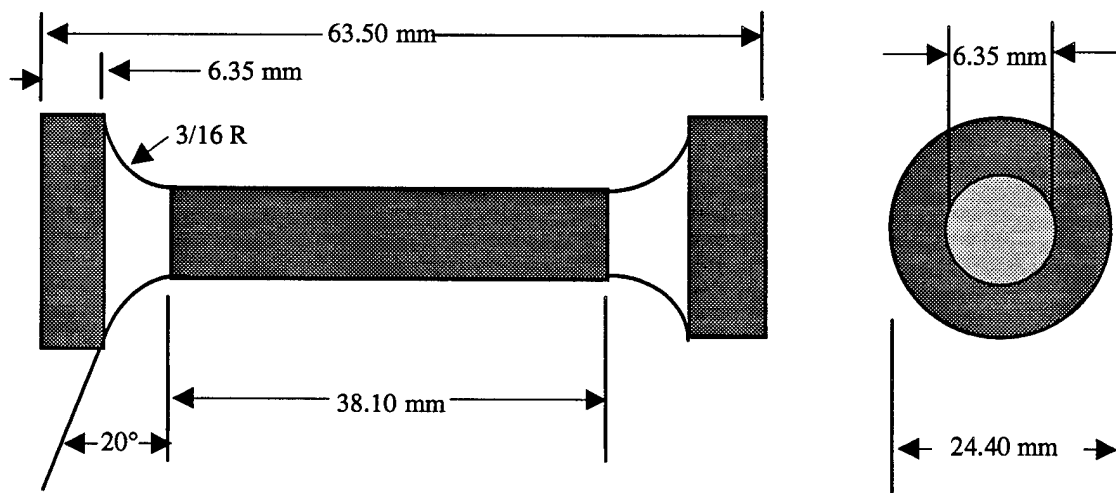

Figure 3. Specimen Geometry.

Table 1. Mechanical and Physical Properties of OFHC Copper (Cu99.95Min)

Melting Point (degrees Celsius)	1,083
Density (g/cm ³) 20° C	8.92
Electrical Resistivity (ohm-m)	1.7×10^{-8}
Youngs Modulus (GPa)	130
Tensile Strength (MPa)	270
Yield Strength (MPa)	200
Elongation (%)	10–45
Vickers Hardness (/MN-m)	369
Poisson's ratio	0.36

3.2 Dynamic Deformation. Dynamic deformation data was acquired using the Kodak Extapro high-speed CCD camera, the Kodak Etapro EM motion analyzer, and a Pentium 100-MHz PC. The motion analyzer was triggered at discrete load levels from a signal acquired by a load cell. The load cell reading was sampled by personal computer 1, and a 5-V trigger signal was sent out to the motion analyzer at a load of 444 N, initiating data acquisition. The load cell reading was then displayed on the digital image using a multiplexer to provide a precise and unambiguous load value for each image obtained. The dynamic testing system was placed under control of personal computer 1 using LABTECH software. A block diagram of the mechanical test system is shown in Figure 4.

The MSRM can be run in two modes of operation: an open loop for higher strain rates (1/s–100/s) and a closed loop for slower rate tests (0.0001/s–1/s). Tests on OFHC copper were conducted in both modes. Tests were initially conducted using a recording rate of 500 frames/s, but were later increased to 1,000 frames/s to allow for smaller displacement measurements in the elastic region of deformation. Measuring elastic deformations has two limitations: one is hardware related, and the other is software related. The smallest measurable strain in the elastic region is determined by the recording rate. For example, a recording rate of 500 frames/s means

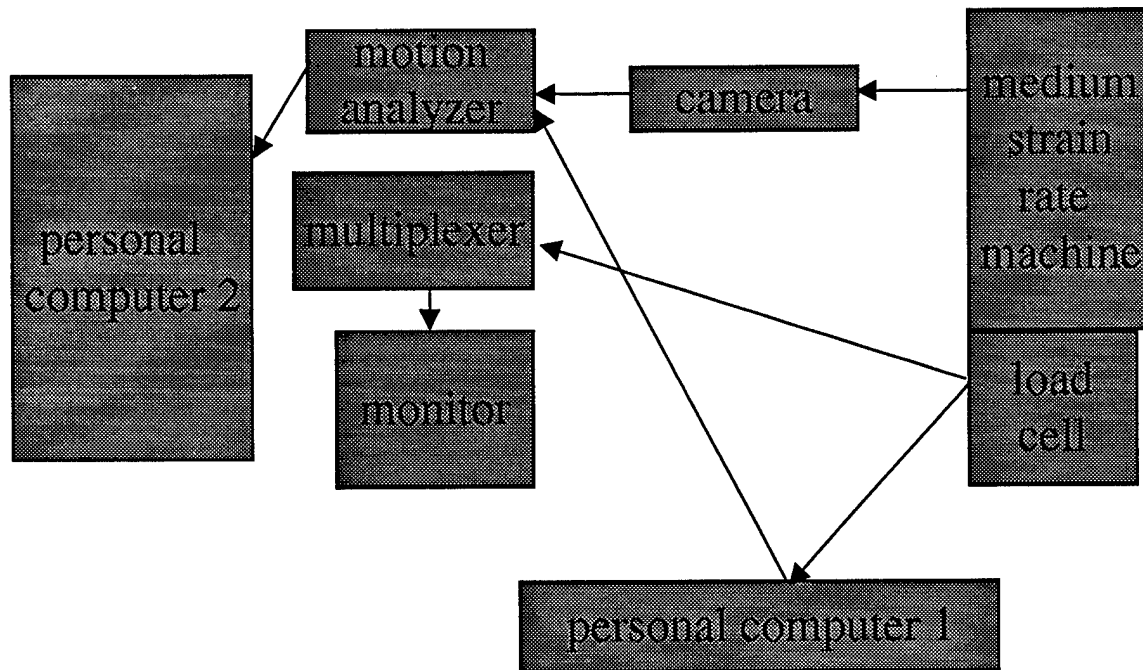

Figure 4. Block Diagram of a Mechanical Test System.

that the smallest measurable time increment is $1/(500)$ or 0.002 s/frame. For an expected strain rate of $1/s$, the smallest measurable strain is 0.2% , which gives only one point in the elastic region. This hardware limitation can be overcome by increasing the recording rate and exposure time, thus giving smaller displacements and more points in the elastic region. The software limitation comes about because very small displacements (less than 0.005%) often produce noise in the results. An upgraded version of the software may be available in the future to correct this problem.

The next step in acquiring dynamic deformation data was to flatten the gage section of cylindrical copper specimen. Due to the cylindrical design of the original specimen, only a narrow portion of the specimen parallel to the image plane of the camera could be used to measure deformations. This narrow portion of the specimen would yield 20–30 pixels (7.4–11.2 mm) of information, not enough to give reliable strain measurements. Flattening the specimen increases the width to approximately 100–125 pixels (37.4–46.4 mm) of information in the transverse direction, and as shown in section 3.3, increases the heating rate substantially.

3.3 Dynamic Deformation of OFHC Copper at High Heating Rates. Dynamic deformation tests were conducted at high heating rates on OFHC copper to determine the mechanical properties under varying rates of deformation. In addition to the basic mechanical test system of Figure 4, a transformer-driven resistance heating system and an optical pyrometer were also incorporated, as shown in Figure 5.

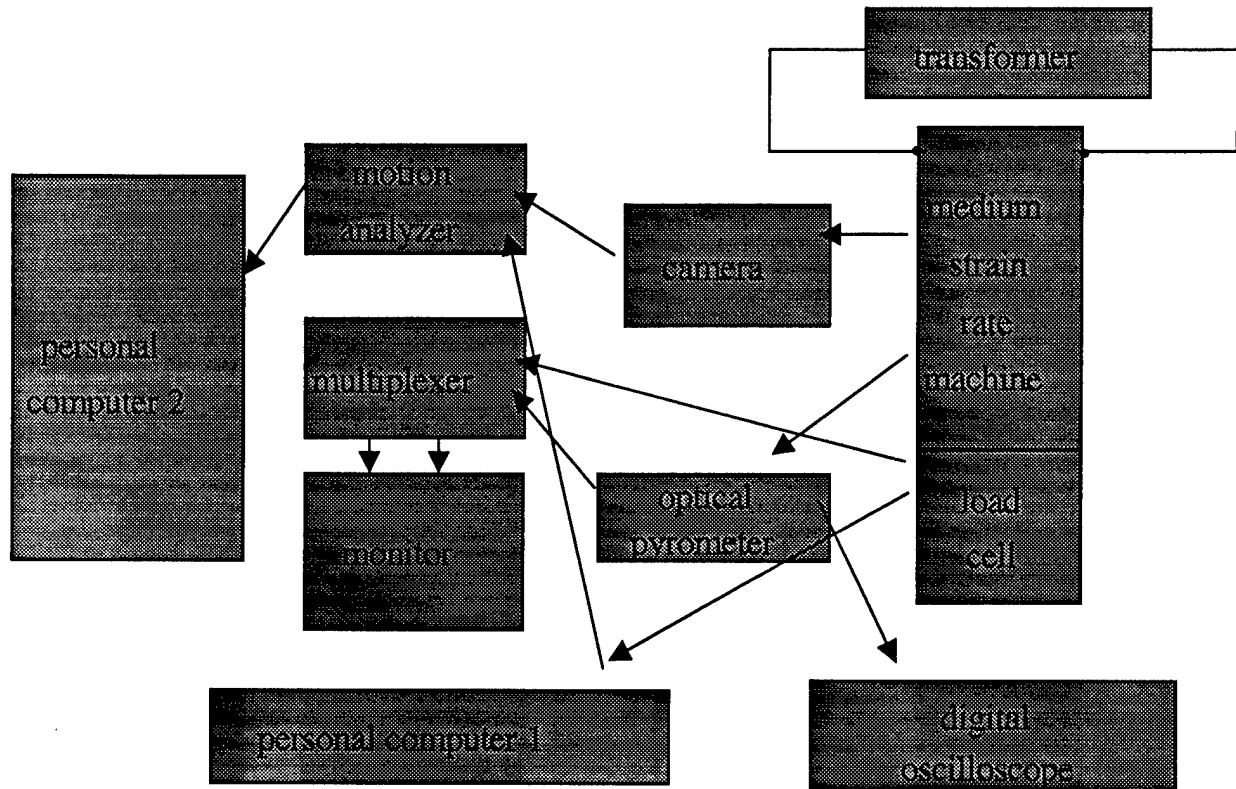

Figure 5. Block Diagram of a High Heating Rate Test System.

A Venzetti optical pyrometer, model 3000, has a response time of 1 ms, which is sufficient for the strain rates studied. The calibration curve of output voltage vs. temperature is shown in Figure 6. The temperature was increased incrementally using the transformer, while the temperature was recorded with a type K thermocouple.

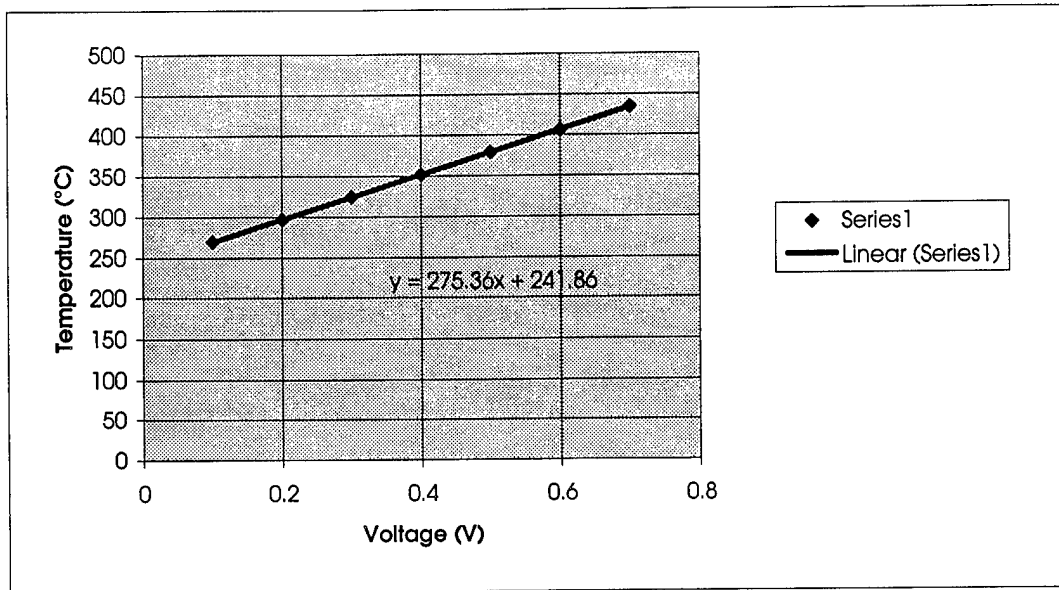

Figure 6. Calibration Curve of Vanzetti Optical Pyrometer.

Specimens were uniformly flattened from a thickness of 6.25 mm to thicknesses in the range of 3.09–3.23 mm. This increased the heating rate and improved transverse strain measurements. The resistance of the specimen increased by a factor of approximately two, and the heating rate by a factor of approximately two to three.

4. Discussion of Experimental Results

The deformation behavior of OFHC copper was measured at different strain rates and heating rates. Tests were conducted under three conditions: two strain rates, static and 1/s at room temperature, and three heating rate tests at a strain rate of 1/s. A summary of the results is shown in Table 2.

4.1 Effects of Strain Rate. Static tests performed at room temperature established the elastic behavior of OFHC copper and were later used to examine the effect of changes in strain rate. To construct a stress-strain curve, images were analyzed along the loading axis. Using plots of displacement in pixels for each subimage vs. position for images at many load levels, the

Table 2. Mechanical Properties of OFHC Copper at Various Strain Rates and Heating Rates

Strain Rate (S ⁻¹)	Temperature (°C)	Heating Rate (°C/s)	0.2% Offset Yield (MPa)	Modulus of Elasticity (GPa)
quasi-static	25	isothermal	325	110
1	25	isothermal	375	95
1	360	30	125	decrease ^a
1	375	263	75	decrease ^a

^a Decreased from room temperature value; numerical values unavailable because only one data point was obtained in the elastic region.

static stress-strain curve for OFHC copper was constructed, as shown in Figure 7. The elastic modulus from the curve is 110 GPa. The elastic limit, 0.2% offset yield, was determined to be approximately 325 MPa. The generally accepted value for the modulus is 117 GPa [6]. The experimental result is only 6% less, which falls well within the accuracy expected for the digital speckle correlation system [3]. Static testing validated the speckle measuring system and provided the basis for studying the effects of strain rate and heating rate on the mechanical behavior of OFHC copper.

The effects of strain rate were examined by comparing the static stress-strain curve with the curve obtained at a strain rate on the order of 1/s, as shown in Figure 8. The elastic modulus decreased, and the elastic limit increased with the increase in strain rate. The elastic modulus decreased nominally from 110 GPa to 95 GPa, and the elastic limit increased from 250 MPa to 360 MPa. In addition to this analysis, the dynamic test was studied further because the region of necking was in the field-of-view of the CCD. The 2-D integrated speckle measuring system enables the user to choose the region to analyze. In this way, the strain in the necked region itself was determined and compared to the average strain across the entire field of view, as shown in Figure 8. As expected, the stress and strain in the necked region is larger than the average strain. In addition, the strain rate in the neck also increases (see Figure 8) where the data points on the curve correspond to the same images, and therefore the same time increments. The study of necking is one benefit of the speckle correlation method of displacement measurement.

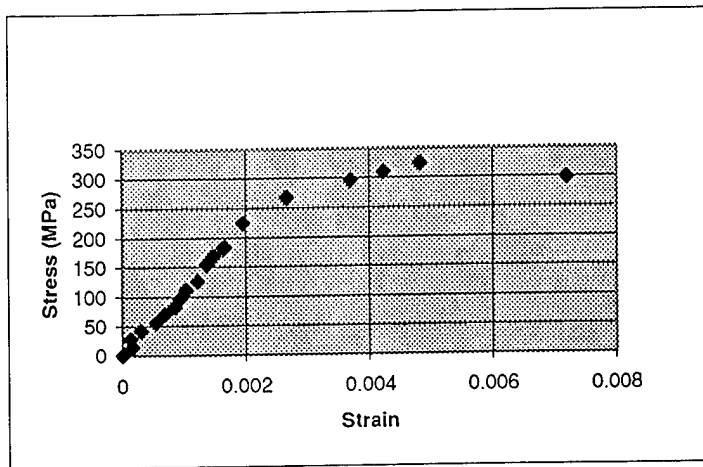

Figure 7. Stress-Strain Curve for Quasi-Static Tests of OFHC Copper.

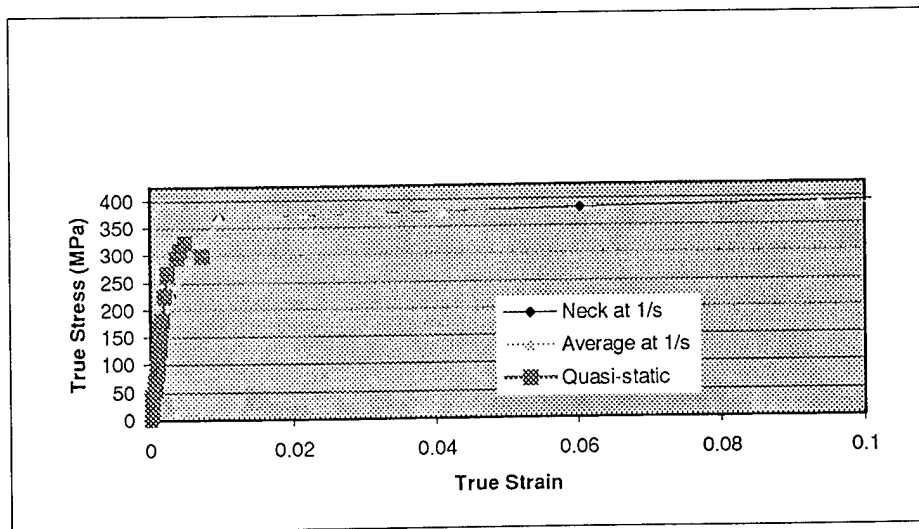

Figure 8. Comparison of Stress-Strain Curves of OFHC Copper for Average Strain in Quasi-Static Test and Average and Necking Region Strains in 1/s Tests.

4.2 Effects of Heating Rate. Because the 2-D integrated speckle measuring system is a noncontact displacement measurement technique, it also allows the study of high heating rate effects on OFHC copper. Before testing the OFHC copper at high heating rates, it was necessary

to calibrate the Vanzetti optical pyrometer, as described in section 3.3. The OFHC copper was heated at 30° C/s to a temperature of 360° C and at 263° C/s to 375° C. It was then pulled in tension at a strain rate of approximately 1/s. Figure 9 shows these heating rate results as well as the results from the room temperature test at the same strain rate. The graph shows that the flow stress for the tests with high temperatures and heating rates is lower than the flow stress at room temperature. This is because the material has softened with the increased temperature. As can also be seen from Figure 9, for a heating rate of 30° C/s, the yield stress decreased from 375 MPa to 125 MPa, and for a heating rate of 263° C/s, the yield stress decreased further to 75 MPa. It should also be noted that all specimens were pulled in tension to failure. A micrograph of OFHC copper is shown in Figures 10a–d under various loading conditions. In Figure 10a, the OFHC copper appears to have undergone some prior work hardening, as evidenced by the slight grain elongation. In Figure 10b, the OFHC copper has undergone more extensive work hardening and grain elongation due to the tensile loading. Figures 10c and 10d show evidence of recrystallization, with Figure 10c showing a smaller new grain size caused by the slower heating rate. In both cases, the recrystallization temperature was probably lowered by the additional work hardening performed during the tension test. Figure 10d also shows some grains that have been unaffected by the recrystallization process due to the rapid heating rate.

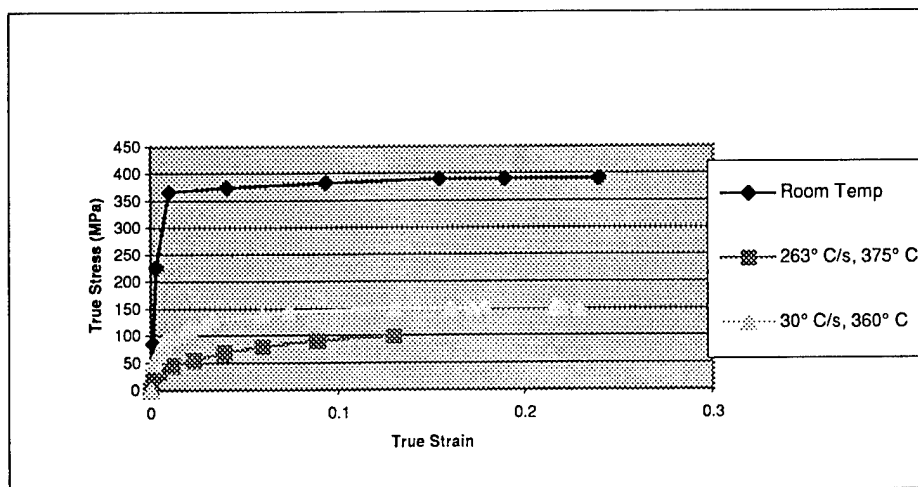

Figure 9. Effects of Heating Rate and Temperature on OFHC Copper Properties.



(a) Initial OFHC Copper Specimen From Bar Stock



(b) Tensile Loaded at a Strain Rate of 1/s

Figure 10. Optical Micrographs of OFHC Copper.

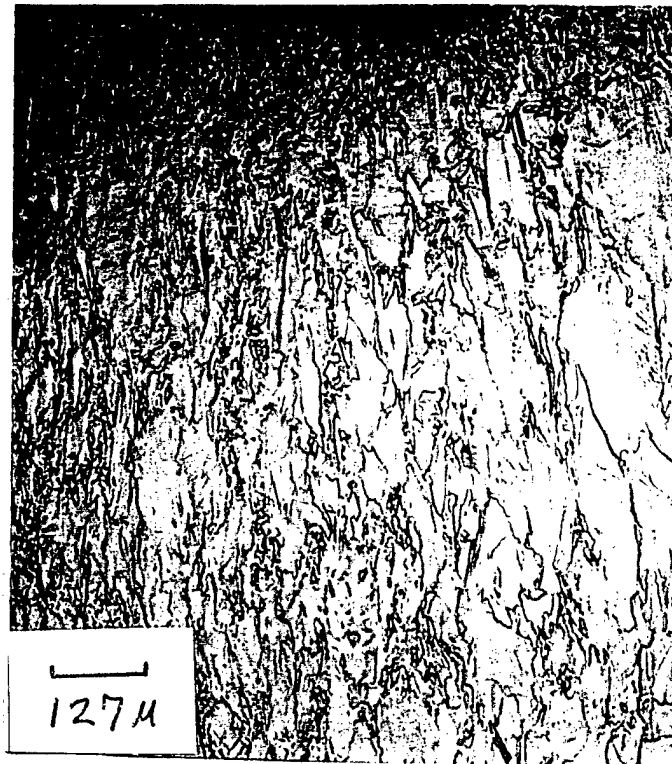

(c) Heated to 360° C/s at a Heating Rate of 30° C/s, Then Tensile Loaded at a Strain Rate of 1/s



(d) Heated to 375° C/s at a Heating Rate of 263° C/s, Then Tensile Loaded at a Strain Rate of 1/s

Figure 10. Optical Micrographs of OFHC Copper (continued).

5. Summary and Conclusions

The 2-D integrated speckle measuring system has been established as a reliable, accurate method for measuring deformations at high heating rates and medium strain rates. Tension tests conducted on OFHC copper specimens showed that it is sensitive to strain rate and to heating rate. The material also showed a distinct softening at elevated temperatures. The elastic modulus decreased from a static value of 110 GPa to a value of 95 GPa, at a strain rate of 1/s at room temperature; the elastic limit increased from 325 MPa to 375 MPa, a 13.8% increase. These results are in agreement with other tests performed on OFHC copper, which also show an increase in flow stress with an increase in strain rate [8]. For a heating rate of 30° C/s, the yield stress decreased from its room temperature value of 325 MPa to 125 MPa, a 61.5% decrease; for a heating rate of 263° C/s, the yield stress further decreased from 325 MPa to 75 Mpa, a 77% decrease. The authors have been unable to find similar heating rate tests in the literature for OFHC copper. However, similar tests conducted on other metallic materials, such as a tungsten alloy, have shown that the flow stress increases as the heating rate increases [1]. This is in disagreement with the results obtained for OFHC copper in this study. This apparent disagreement can be explained in two ways: the OFHC copper has a face-centered cubic (fcc) structure, where the tungsten has a body-centered cubic (bcc) structure; therefore, the metals are structurally dissimilar, and the tungsten was heated to a temperature well below its recrystallization temperature. None of the micrographs showed any evidence of microbands.

One problem encountered during testing is that the final temperature of the specimen was not controlled as precisely as expected; therefore, the effect of this temperature variation is not clear at this time, particularly since this temperature is so close to the recrystallization temperature of OFHC copper. After modifying the test controls and procedure, additional high heating rate tests will be conducted on OFHC copper at different heating rates and temperatures.

Strain rate tests and heating rate tests similar to these have important implications not only in the armor penetration process, but also in the airline industry, where many airplane components undergo high heating rates, high temperatures, rapid cooling, and high strain rates. Tests such as

these play an important role in both relating the microstructure to the mechanical properties of a material and providing material constants used in material modeling.

6. References

1. Green, J. L. "Mechanical Behavior of 97.2 5W Alloy in Tension at High Temperatures." ARL-TR-508, U.S. Army Research Laboratory, Watertown, MA, September 1994.
2. Shankaranarayan, H., and S. K. Varma. "Strain-Rate and Grain Size Effect on Substructures and Mechanical Properties in OFHC Copper During Tension." *Journal of Materials Science*, July 1995.
3. Bruck, H. A. "Measuring Heating Rate Effects on the Dynamic Mechanical Behavior of OFHC Copper Using Laser and White Light Speckle Correlation." University of South Carolina, Columbia, SC, for U.S. Army Research Office, Research Triangle Park, NC, February 1998.
4. Chen, D. J., F. P. Chiang, Y. S. Tan, and H. S. Don. "Digital Speckle-Displacement Measurement Using a Complex Spectrum Method." *Applied Optics*, April 1993.
5. Sutton, M. A., J. L. Turner, H. A. Bruck, and T. A. Chae. "Full-Field Representation of Discretely Sampled Surface Deformation for Displacement and Strain Analysis." *Experimental Mechanics*, vol. 31, 1991.
6. Uniform Tubes Europe, Unit E3. Brookside Park, Greengate, Chadderton, Manchester, UK. <http://www.uniformtubes.co.uk/ofhc.html>, May 1999.
7. Personal Communication. University of Hawaii.
See also <http://kupono.ifa.hawaii.edu/WEB/IRCS/Mat-data.html>, May 1999.
8. Johnson, G. R., and W. H. Cook. "A Constitutive Model and Data for Metals Subjected to Large Strains, High Strain Rates and High Temperatures." *Seventh International Ballistics Symposium*, The Hague, Netherlands, 1983.
9. The University of Queensland. Brisbane, Queensland, 4072 Australia.
<http://mama.minmet.uq.oz.au>, May 1999.

INTENTIONALLY LEFT BLANK.

<u>NO. OF COPIES</u>	<u>ORGANIZATION</u>	<u>NO. OF COPIES</u>	<u>ORGANIZATION</u>
2	DEFENSE TECHNICAL INFORMATION CENTER DTIC DDA 8725 JOHN J KINGMAN RD STE 0944 FT BELVOIR VA 22060-6218	1	DIRECTOR US ARMY RESEARCH LAB AMSRL D D R SMITH 2800 POWDER MILL RD ADELPHI MD 20783-1197
1	HQDA DAMO FDT 400 ARMY PENTAGON WASHINGTON DC 20310-0460	1	DIRECTOR US ARMY RESEARCH LAB AMSRL DD 2800 POWDER MILL RD ADELPHI MD 20783-1197
1	OSD OUSD(A&T)/ODDDR&E(R) R J TREW THE PENTAGON WASHINGTON DC 20301-7100	1	DIRECTOR US ARMY RESEARCH LAB AMSRL CS AS (RECORDS MGMT) 2800 POWDER MILL RD ADELPHI MD 20783-1145
1	DPTY CG FOR RDA US ARMY MATERIEL CMD AMCRDA 5001 EISENHOWER AVE ALEXANDRIA VA 22333-0001	3	DIRECTOR US ARMY RESEARCH LAB AMSRL CI LL 2800 POWDER MILL RD ADELPHI MD 20783-1145
1	INST FOR ADVNCD TCHNLGY THE UNIV OF TEXAS AT AUSTIN PO BOX 202797 AUSTIN TX 78720-2797		<u>ABERDEEN PROVING GROUND</u>
1	DARPA B KASPAR 3701 N FAIRFAX DR ARLINGTON VA 22203-1714	4	DIR USARL AMSRL CI LP (BLDG 305)
1	NAVAL SURFACE WARFARE CTR CODE B07 J PENNELLA 17320 DAHLGREN RD BLDG 1470 RM 1101 DAHLGREN VA 22448-5100		
1	US MILITARY ACADEMY MATH SCI CTR OF EXCELLENCE DEPT OF MATHEMATICAL SCI MADN MATH THAYER HALL WEST POINT NY 10996-1786		

<u>NO. OF</u> <u>COPIES</u>	<u>ORGANIZATION</u>
1	CDR USA ARDEC G FLEMING PICATINNY ARSENAL NJ 07806-5000
2	CDR USA ARDEC AMSTA AR FSA E E BAKER D KAPOOR PICATINNY ARSENAL NJ 07806-5000
2	SOUTHWEST RSCH INST C ANDERSON J LANKFORD PO DRAWER 28510 SAN ANTONIO TX 78228-0510
1	DIR LOS ALAMOS NATL LAB MS B296 G T GRAY PO BOX 1663 LOS ALAMOS NM 87545
1	EGLIN AFB WRIGHT LAB TECH LIB ARMAMENT DIV J FOSTER 101 ELGIN AVE STE 239 EGLIN AFB FL 32542-5000
1	DIR LOS ALAMOS NATL LAB D RABERN GROUP MEE 13 MSJ576 LOS ALAMOS NM 87545
1	DIR LOS ALAMOS NATL LAB TECH LIB PO BOX 1663 LOS ALAMOS NM 87545

<u>NO. OF</u> <u>COPIES</u>	<u>ORGANIZATION</u>
1	JOHNS HOPKINS UNIVERSITY DEPT MECH ENGRG K RAMESH CHARLES AND 33 ST BALTIMORE MD 21218
1	BROWN UNIVERISTY DIV OF ENGRG R CLIFTON PROVIDENCE RI 02912
1	UC SAN DIEGO DEPT APPL MECH AND ENG SVCS R011 S NEMAT NASSER LA JOLLA CA 92093-0411
1	CALTECH G RAVICHANDRAN MS 105 50 1201 E CALIFORNIA BLVD PASADENA CA 91125
1	INST OF ADVANCE TECH UNIV OF TX AUSTIN S J BLESS 4030 2 W BRAKER LN AUSTIN TX 78759
1	CDR USARO K IYER PO BOX 12211 RESEARCH TRIANGLE PARK NC 27709-2211
1	VIRGINIA POLYTECHNIC INST COLLEGE OF ENGRG R BATRA BLACKSBURG VA 24061-0219
1	DIR LLNL D LASILA L 170 LIVERMORE CA 94550

NO. OF
COPIES ORGANIZATION

ABERDEEN PROVING GROUND

47 DIR USARL
AMSRL WM TD
A M DIETRICH
D DANDEKAR
A RAJENDRAN
K FRANK
T HADUCH
T WRIGHT
E RAPACKI
N RUPERT
P KINGMAN
M SCHEIDLER
B DURANT (15 CPS)
AMSRL WM TC
T BJERKE
E KENNEDY
R MUDD
W WALTERS
L MAGNESS
R COATES
B SORENSON
D SCHEFFLER
K KIMSEY
AMSRL WM TA
W GILLICH
M BURKINS
J RUNYEON
W A GOOCH
G FILBEY
AMSRL WM MC
R ADLER
M STAKER
G KRASKO
AMSRL WM MD
W DE ROSSET
R DOWDING
K CHO
AMSRL WM MB
C HOPPEL
G GAZONAS

INTENTIONALLY LEFT BLANK.

REPORT DOCUMENTATION PAGE

Form Approved
OMB No. 0704-0188

Public reporting burden for this collection of information is estimated to average 1 hour per response, including the time for reviewing instructions, searching existing data sources, gathering and maintaining the data needed, and completing and reviewing the collection of information. Send comments regarding this burden estimate or any other aspect of this collection of information, including suggestions for reducing this burden, to Washington Headquarters Services, Directorate for Information Operations and Reports, 1215 Jefferson Davis Highway, Suite 1204, Arlington, VA 22202-4302, and to the Office of Management and Budget, Paperwork Reduction Project(0704-0188), Washington, DC 20503.

1. AGENCY USE ONLY (Leave blank)

2. REPORT DATE

June 2000

3. REPORT TYPE AND DATES COVERED

Final, Sep 97 - Sep 98

4. TITLE AND SUBTITLE

A Study of the Mechanical Behavior of OFHC Copper in Tension at Various Strain Rates and Heating Rates Using the Two-Dimensional Integrated Speckle Measuring System

5. FUNDING NUMBERS

62618AH80

6. AUTHOR(S)

Brian G. Durant and Nathaniel D. Bruchey*

7. PERFORMING ORGANIZATION NAME(S) AND ADDRESS(ES)

U.S. Army Research Laboratory
ATTN: AMSRL-WM-TD
Aberdeen Proving Ground, MD 21005-5066

8. PERFORMING ORGANIZATION REPORT NUMBER

ARL-TR-2248

9. SPONSORING/MONITORING AGENCY NAMES(S) AND ADDRESS(ES)

*Dynamic Science Inc.

10. SPONSORING/MONITORING AGENCY REPORT NUMBER

11. SUPPLEMENTARY NOTES

12a. DISTRIBUTION/AVAILABILITY STATEMENT

Approved for public release; distribution is unlimited.

12b. DISTRIBUTION CODE

13. ABSTRACT (Maximum 200 words)

The objective was to investigate the mechanical behavior of oxygen-free high-conductivity (OFHC) copper in tension. A modified dog bone specimen was heated using resistive heating techniques. The effects of high temperature, medium strain rates, and high heating rates on the stress-strain results were observed. A new two-dimensional (2-D) integrated speckle measuring system and a high-speed optical pyrometer were utilized for strain and temperature measurements. Room temperature tests were conducted at strain rates of quasi-static and 1/s. The high heating rate experiments were conducted at temperatures of 360 C and 375 C, heating rates of 30 C/s and 263 C/s, and at a strain rate of 1/s. A nominal decrease in the elastic modulus and an increase in the elastic limit are seen for increasing strain rate. Decreases in yield stress and flow stress were observed as the heating rate was increased.

14. SUBJECT TERMS

OFHC copper, tension, speckle, measuring system, strain rate, heating rate, elastic modulus, yield stress

15. NUMBER OF PAGES

29

16. PRICE CODE

17. SECURITY CLASSIFICATION OF REPORT

UNCLASSIFIED

18. SECURITY CLASSIFICATION OF THIS PAGE

UNCLASSIFIED

19. SECURITY CLASSIFICATION OF ABSTRACT

UNCLASSIFIED

20. LIMITATION OF ABSTRACT

UL

INTENTIONALLY LEFT BLANK.

USER EVALUATION SHEET/CHANGE OF ADDRESS

This Laboratory undertakes a continuing effort to improve the quality of the reports it publishes. Your comments/answers to the items/questions below will aid us in our efforts.

1. ARL Report Number/Author ARL-TR-2248 (Durant) Date of Report June 2000

2. Date Report Received _____

3. Does this report satisfy a need? (Comment on purpose, related project, or other area of interest for which the report will be used.) _____

4. Specifically, how is the report being used? (Information source, design data, procedure, source of ideas, etc.) _____

5. Has the information in this report led to any quantitative savings as far as man-hours or dollars saved, operating costs avoided, or efficiencies achieved, etc? If so, please elaborate. _____

6. General Comments. What do you think should be changed to improve future reports? (Indicate changes to organization, technical content, format, etc.) _____

CURRENT
ADDRESS

Organization

Name

E-mail Name

Street or P.O. Box No.

City, State, Zip Code

7. If indicating a Change of Address or Address Correction, please provide the Current or Correct address above and the Old or Incorrect address below.

OLD
ADDRESS

Organization

Name

Street or P.O. Box No.

City, State, Zip Code

(Remove this sheet, fold as indicated, tape closed, and mail.)

(DO NOT STAPLE)