

ARMY RESEARCH LABORATORY



The Effect of Thermo-mechanical Processing on  
the Ballistic Limit Velocity of Extra Low  
Interstitial Titanium Alloy Ti-6AL-4V

Matthew S. Burkins  
Jeffrey S. Hansen  
Jack I. Paige  
Paul C. Turner

ARL-MR-486

JULY 2000

20000727 163

Approved for public release; distribution is unlimited.

DTIC QUALITY INSPECTED 4

The findings in this report are not to be construed as an official Department of the Army position unless so designated by other authorized documents.

Citation of manufacturer's or trade names does not constitute an official endorsement or approval of the use thereof.

Destroy this report when it is no longer needed. Do not return it to the originator.

# Army Research Laboratory

Aberdeen Proving Ground, MD 21005-5066

---

---

ARL-MR-486

July 2000

---

## The Effect of Thermo-mechanical Processing on the Ballistic Limit Velocity of Extra Low Interstitial Titanium Alloy Ti-6AL-4V

Matthew S. Burkins

Weapons & Materials Research Directorate, ARL

Jeffrey S. Hansen

Jack I. Paige

Paul C. Turner

U.S. Department of Energy

---

Approved for public release; distribution is unlimited.

---

---

---

---

## Abstract

---

Although titanium alloys have been widely used for aerospace applications, they have seldom been used in armor systems. In an effort to provide increased information to armored vehicle designers, the U.S. Army Research Laboratory (ARL) and the U.S. Department of Energy's Albany Research Center (ARC) performed a joint research program to evaluate the effect of thermo-mechanical processing on the ballistic limit velocity for an extra-low interstitial grade of the titanium alloy Ti-6Al-4V. ARC obtained MIL-T-9046J, AB-2 plates from RMI<sup>1</sup> Titanium Company, rolled these plates to final thickness, performed the annealing, and collected mechanical and micro-structural information. ARL then evaluated the plates with 20-mm fragment-simulating projectiles and 12.7-mm armor-piercing M2 bullets in order to determine the ballistic limit velocity of each plate. Titanium processing and annealing did have an effect on the ballistic limit velocity, but the magnitude of the effect depended on which penetrator was used.

---

<sup>1</sup>formerly Refractory Metals, Inc.

## TABLE OF CONTENTS

	<u>Page</u>
List of Figures .....	v
List of Tables .....	vii
1. Introduction .....	1
2. Background .....	1
3. Projectiles .....	3
4. Methodology .....	5
5. Metallographic Analysis .....	6
6. Results .....	7
7. Conclusions .....	14
References .....	17
Appendices	
A. Metallographic Analysis and Tensile Data .....	19
B. Ballistic Data .....	33
Distribution List .....	51
Report Documentation Page .....	59

INTENTIONALLY LEFT BLANK

## LIST OF FIGURES

<u>Figure</u>		<u>Page</u>
1.	Projectiles . . . . .	5
2.	Schematic of Setup . . . . .	6
3.	$V_{50}$ Difference for Various Processing Conditions . . . . .	10
4.	Cross Section of Impact Crater From 20-mm FSP for Beta-Processed Plate No. 315, Type C5, Shot No. 4065 . . . . .	11
5.	Cross Section of Impact Crater From 20-mm FSP for Alpha-Beta-Processed Plate No. 317, Type C1, Shot No. 4319 . . . . .	11
6.	Rear Surface of Beta-Processed Plate No. 302, Type S2, Shot No. 5472 After a Nearly Perforating Impact by a 12.7-mm AP M2 Projectile . .	13
7.	Rear Surface of Alpha-Beta-Processed Plate No. 312, Type S1, Shot No. 5450 After a Nearly Perforating Impact by a 12.7-mm AP M2 Projectile . . . . .	13
8.	Effect of Surface Finish on $V_{50}$ Difference for the 20-mm FSP . . . . .	14

INTENTIONALLY LEFT BLANK

## LIST OF TABLES

<u>Table</u>		<u>Page</u>
1.	Chemical Composition of Titanium Plates by Weight Percent . . . . .	2
2.	Minimum Transverse Mechanical Properties Required for 25.4-mm-Thick Titanium Plates . . . . .	2
3.	Transverse Mechanical Properties Obtained for 25.4-mm-Thick Titanium Plates . . . . .	4
4.	V <sub>50</sub> Ballistic Limit Results for the 20-mm FSP . . . . .	8
5.	V <sub>50</sub> Ballistic Limit Results for the 12.7-mm AP M2 . . . . .	9
6.	Effect of Surface Finish on V <sub>50</sub> Ballistic Limit for the 20-mm FSP . . .	14

INTENTIONALLY LEFT BLANK

# THE EFFECT OF THERMO-MECHANICAL PROCESSING ON THE BALLISTIC LIMIT VELOCITY OF EXTRA LOW INTERSTITIAL TITANIUM ALLOY Ti-6Al-4V

---

## 1. Introduction

---

Although titanium alloys have been used successfully in aircraft for many years, the relatively high cost of titanium, coupled with the sparse information about its ballistic properties, has prevented widespread use of titanium in ground vehicles. As early as 1950, Pitler and Hurlich [1] noted that titanium showed promise as a structural armor against small arms projectiles. By 1964, Ti-6Al-4V alloy, extra-low interstitial (ELI) grade, had become the material of choice for armor applications. Ballistic testing had indicated that reductions in interstitial elements such as carbon, oxygen, nitrogen, and hydrogen improved the ductility and thus, the ballistic protection of the plate.[2] Consequently, the MIL-A-46077 armor specification was developed for ELI grade Ti-6Al-4V. However, with titanium production methodology still in its infancy, the effect of thermo-mechanical processing on ballistic performance was never completely explored.

In an effort to provide increased information to armored vehicle designers, the U.S. Army Research Laboratory (ARL) and the U.S. Department of Energy's Albany Research Center (ARC) performed a joint research program to evaluate the effect of thermo-mechanical processing on the ballistic limit velocity of an ELI grade of Ti-6Al-4V. ARC obtained MIL-T-9046J, AB-2 plates from RMI<sup>1</sup> Titanium Company, rolled these plates to final thickness, performed the annealing, and collected mechanical and micro-structural information. MIL-T-9046J, a Navy specification in common use by the aerospace community, has similar chemical composition requirements as MIL-A-46077 but has no ballistic requirements. ARL then evaluated the plates with 20-mm fragment-simulating projectiles (FSPs) and 12.7-mm armor-piercing (AP) M2 bullets in order to determine the ballistic limit velocity of each plate. The ballistic limit velocities were then compared to assess the effect of changes in rolling and heat treatment.

---

## 2. Background

---

Titanium can exist in a hexagonal closely packed crystal structure (known as the alpha phase) and a body-centered cubic structure (known as the beta phase). In unalloyed titanium, the alpha phase is stable at all temperatures as high as 883° C, where it transforms to the beta phase. This transformation temperature is known as

---

<sup>1</sup>formerly Refractory Metals, Inc.

the beta transus temperature. The beta phase is stable from 883° C to the melting point. As alloying elements are added to pure titanium, the phase transformation temperature and the amount of each phase change. Alloy additions to titanium, except tin and zirconium, tend to stabilize either the alpha or beta phase. Ti-6Al-4V, the most common titanium alloy, contains mixtures of alpha and beta phases and is therefore classified as an alpha-beta alloy. The aluminum is an alpha stabilizer, which stabilizes the alpha phase to higher temperatures, and the vanadium is a beta stabilizer, which stabilizes the beta phase to lower temperatures. The addition of these alloying elements raises the beta transus temperature to approximately 996° C. Alpha-beta alloys, such as Ti-6Al-4V, are of interest for armor applications because they are generally weldable, can be heat treated, and offer moderate to high strength.[3]

Ti-6Al-4V alloy can be ordered to meet a variety of commercial and military specifications. ELI grade plates, with a chemical composition simultaneously conforming to the MIL-T-9046J, AB-2 (aerospace) and MIL-A-46077D (armor) specifications, were selected for this analysis because this is the only “off-the-shelf” armor alloy. The specifications define alloy chemistry ranges, minimum mechanical properties, and, in the case of MIL-A-46077D, ballistic requirements. The chemical composition and minimum mechanical properties are listed in Tables 1 and 2, respectively. Transverse properties are determined from samples taken perpendicular to the final rolling direction.

Table 1. Chemical Composition of Titanium Plates by Weight Percent

	Al	V	C	O	N	H	Fe	Other	Ti
MIL-A-46077D	5.5–6.5	3.5–4.5	0.04 max.	0.14 max.	0.02 max.	0.0125 max.	0.25 max.	0.40 max.	Balance
MIL-T-9046J AB-2	5.5–6.5	3.5–4.5	0.08 max.	0.13 max.	0.05 max.	0.0125 max.	0.25 max.	0.30 max.	Balance
As Delivered	6.12	4.02	0.01	0.12	0.008	0.0014	0.19	<0.40	Balance

Notes: Al - aluminum, V - vanadium, C - carbon, O - oxygen, N - nitrogen, H - hydrogen, Fe - iron, Ti - titanium, and max. - maximum.

Table 2. Minimum Transverse Mechanical Properties Required for 25.4-mm-Thick Titanium Plates

Specification	Ultimate Tensile Strength (MPa)	Yield Strength, 0.2% Offset (MPa)	Elongation (percent)	in area (percent)
MIL-A-46077D	896	827	14	30
MIL-T-9046J, AB-2	896	827	10	not required

The starting material was commercially produced, 127-mm-thick Ti-6Al-4V ELI alloy plate product manufactured by the RMI Titanium Company. Each plate was coated with a silica-based material to reduce oxygen contamination, placed into the furnace, and soaked for 2 hours at either 1,066° C (beta) or 954° C (alpha-beta), and step forged to 108 mm first and then 89 mm. The step forging was done without re-heating. Upon completion, the plates were returned to the furnace and re-heated for 20 minutes. The plates were then either unidirectionally (straight) rolled or cross rolled at the same temperature used in the forging operation (1,066° C or 954° C). The rolling schedule consisted of two passes at 12% reduction in thickness, two passes at 15% reduction in thickness, three passes at 20% reduction in thickness, and one final pass at the final mill setting of 25.4 mm. Each plate was re-heated for 20 minutes after every second pass through the mill. Following the final pass, the plates were placed on a rack and air cooled to room temperature.

Four different annealing heat treatments were used at the completion of rolling and air cooling: (1) a beta anneal at 1,038° C for 30 minutes with an air cool (AC); (2) a beta plus alpha-beta anneal at 1,038° C for 30 minutes with an AC, followed by 788° C for 30 minutes with an AC; (3) an alpha-beta anneal at 788° C for 30 minutes with an AC; and (4) a solution treatment and aging (STA) at 927° C for 30 minutes with a water quenching (WQ), followed by 538° C for 6 hours with an AC. As an experimental control, the final heat treatment was omitted for some of the plates. Following heat treatment, all the plates were sand blasted to remove any remaining protective coating.

Two plates were produced for each of 11 processing conditions. Table 3 lists the processing conditions and the mechanical properties obtained by averaging the results from four specimens taken from each condition. Since the MIL-A-46077D armor specification has minimum requirements for the transverse direction only, ultimate tensile strength, yield strength, elongation, and reduction in area were obtained for only the transverse direction. Note that only plate type C4 met the minimum elongation requirements of MIL-A-46077D. Also, in many cases, the plates failed to meet the yield strength and reduction in area requirements. Charpy impact testing, although not a requirement of MIL-A-46077D, was also conducted in the transverse longitudinal direction.

---

### **3. Projectiles**

---

The 20-mm FSP and the 12.7-mm AP M2 projectiles, shown in Figure 1, were selected for this study because both projectiles are listed in MIL-A-46077D as appropriate for the given plate thickness. The 20-mm FSP, which simulates the steel fragments ejected from high-explosive artillery rounds, was manufactured from 4340H steel in accordance with specification MIL-P- 46593A.

Table 3. Transverse Mechanical Properties Obtained for 25.4-mm-Thick Titanium Plates

Plate Type	Plate Ident.No.	Roll Direction	Roll Temp (°C)	Anneal Schedule	Ult Tensile Strength (MPa)	Yield Strength (MPa)	Elongation (percent)	Reduction in Area (percent)	Charpy Impact (J)
S1	312, 313	Straight	954	788° C, 30 min, AC	972.2	923.9	12.4	15.8	32.66
C1	316, 317	Cross	954	788° C, 30 min, AC	966.7	926.0	13.7	33.4	30.63
C2	318, 319	Cross	954	1,038° C, 30 min, AC	918.4	816.3	10.4	19.6	30.53
C3	320, 321	Cross	954	1,038° C, 30 min, AC	909.4	841.9	10.5	20.6	25.71
C4	322, 323	Cross	954	788° C, 30 min, AC	988.7	939.1	14.2	30.9	45.80
C5	314, 315	Cross	1,066	788° C, 30 min, AC	886.7	810.1	11.7	22.3	30.61
S2	302, 303	Straight	1,066	788° C, 30 min, AC	905.3	835.6	11.1	12.9	29.04
S3	304, 305	Straight	1,066	1,038° C, 30 min, AC	913.6	812.9	8.1	17.9	35.24
S4	306, 307	Straight	1,066	1,038° C, 30 min, AC	905.3	842.5	8.7	17.3	27.89
S5	308, 309	Straight	1,066	None	915.6	819.1	10.1	22.2	31.67
S6	310, 311	Straight	1,066	STA 927° C, 30 min, WQ 538° C, 6 hrs, AC	994.9	927.4	8.5	15.8	30.25

Notes: AC = Air cooled, STA = Solution treat and aged, WQ = Water quenched.  
Charpy impact specimens were tested in the transverse-longitudinal direction.

The 12.7-mm AP M2 is a standard machine gun bullet that has been in service for many decades throughout the world. The AP M2 has a copper jacket over a hardened ( $R_C$  60–65) steel core. Each projectile was fired from the appropriate rifled Mann barrel, and the propellant load was varied in order to adjust velocity. For both projectiles, at least 20 mm of undisturbed material was maintained between adjacent projectile impacts on the plate.

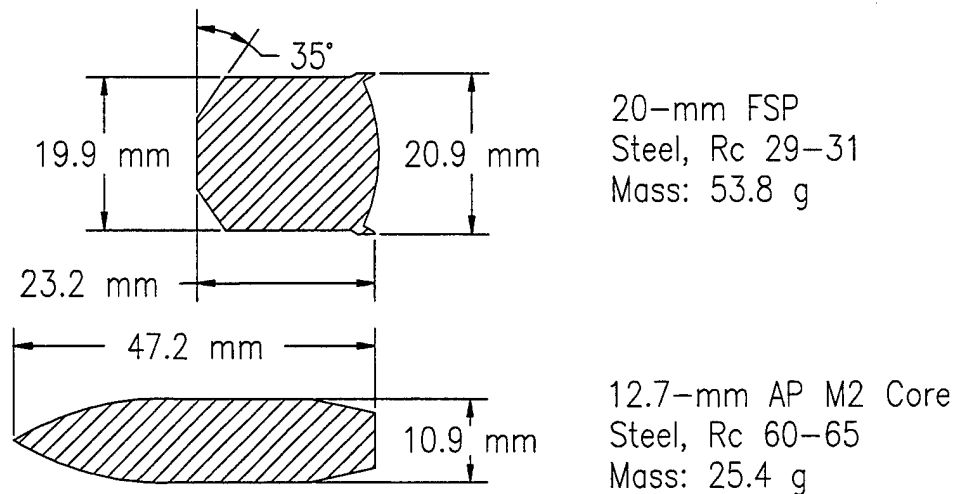

Figure 1. Projectiles.

---

#### 4. Methodology

---

Projectile velocities were measured with an orthogonal flash x-ray system developed by Grabarek and Herr.[4] The titanium plates were placed so that the projectile impacted normal to the plate ( $0^\circ$  obliquity). The orthogonal pair of x-ray tubes permitted the measurement of projectile velocity, vertical pitch, and horizontal yaw just before the projectile impacted the titanium plate. A single pair of x-ray tubes was used to measure the velocity and length of any projectile or target fragments ejected from the rear surface of the target plate. The perforation of a paper break screen initiated the flash x-rays. Whenever possible, the residual penetrator and target material ejected from the plate were collected for analysis. A schematic of the target setup is shown in Figure 2.

Evaluation was performed to obtain a  $V_{50}$  ballistic limit velocity, hereafter referred to as a  $V_{50}$ . The methodology for obtaining a  $V_{50}$  is explained in U.S. Army Test and Evaluation Command (ATEC) test operations procedure (TOP) 2-2-710 [5] but is summarized here. The  $V_{50}$  is obtained by holding target thickness and obliquity constant while varying projectile velocity by adjusting the weight of propellant. When a projectile impacts a target, the result is either a complete penetration (CP) or a partial penetration (PP). For this investigation, a CP occurs

whenever a piece of penetrator or target material perforates the rear break screen and subsequently appears in the x-ray image. A PP is any impact that is not a CP. For the 20-mm FSP, any PP result when the total yaw (vector sum of vertical pitch and horizontal yaw) was greater than  $5^\circ$  was excluded from analysis in order to keep projectile orientation from influencing the results. For the 12.7-mm AP M2, PP results when the total yaw was greater than  $3^\circ$  were excluded from the analysis for the same reason.

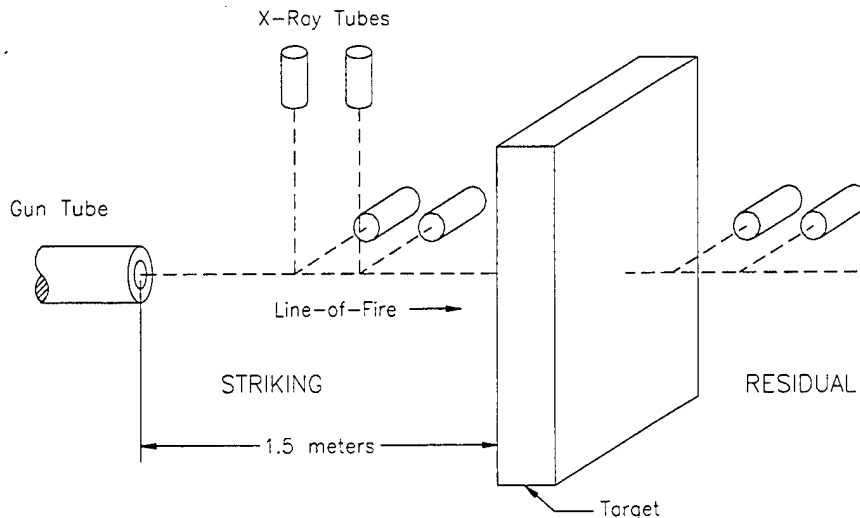

Figure 2. Schematic of Setup.

As projectile velocity is increased, the projectile impact should produce a transition from PPs to CPs at some critical velocity. Assuming that the target-penetrator interaction can be modeled by a cumulative normal (Gaussian) distribution, then a mean ( $V_{50}$ ) and standard deviation (SD) can be determined if a sufficient number of shots were fired. The  $V_{50}$  was determined with equal numbers of PP and CP results over a designated velocity range specified by the MIL-A-46077 titanium armor specification.

---

## 5. Metallographic Analysis

---

A sample was taken from each of the 11 plate types in order to perform metallographic analyses and mechanical tensile testing. Photo-micrographs and tensile testing data are provided in Appendix A. All plates forged, rolled, or annealed in the beta region had a typical structure of plate-like alpha and intergranular beta with alpha at the prior beta grain boundaries. All plates forged, rolled, and annealed in the alpha-beta region had a typical structure of equiaxed alpha grains and intergranular beta.

---

## 6. Results

---

Of the 22 plates provided, half of the plates were evaluated with the 20-mm FSP and the other half were evaluated with the 12.7-mm AP M2.  $V_{50}$  limit velocities were obtained for all plates. Table 4 lists the processes, plate thicknesses,  $V_{50}$  limit velocities, and standard deviations for investigation with the 20-mm FSP. Table 5 provides the same information for the 12.7-mm AP M2. Detailed ballistic test data are presented in Appendix B. Since the thickness of the plates varied slightly, the  $V_{50}$  results had to be normalized to a single reference.

The mechanism for normalizing the data was to use the difference between the limit velocity obtained through testing and the limit velocity for the same thickness plate obtained from the MIL-A-46077D specification. Equation (1) shows the calculation for the  $V_{50}$  difference:

$$V_{50} \text{ Difference} = \text{Test } V_{50} - \text{Required } V_{50} \quad (1)$$

in which required  $V_{50}$  is derived from the MIL-A-46077D specification.

Normalization is achieved because the required  $V_{50}$  term changes as a function of thickness, thus preventing the results from favoring the thicker plates. A positive number obtained for the  $V_{50}$  difference is the margin by which the plate exceeds the specification minimum. Plates that exceed the specification minimum are listed in bold in Tables 4 and 5. Conversely, a negative value for  $V_{50}$  difference indicates the margin by which the plate failed the specification. Figure 3 shows graphically the  $V_{50}$  difference for the 11 plate conditions.

Regardless of the penetrator used, only three plate types (S1, C1, and C4) passed the ballistic requirements of MIL-A-46077D. Note that two of these three plate types also failed to meet the elongation requirements of MIL-A-46077D. Prior data [6] seemed to show some correlation between reduction in area and ballistic performance, but plate type S1 provided good ballistic performance with a relatively poor reduction in area. For this program, there was no correlation between adequate ballistic performance (as required in MIL-A-46077D) and ultimate tensile strength, yield strength, elongation, reduction in area, or Charpy impact energy.

Beta-processed plates (those that were either rolled or annealed at temperatures above the beta transus) had lower  $V_{50}$  ballistic limit velocities for both the 20-mm FSP and the 12.7-mm AP M2. The magnitude of the effect was much greater for the 20-mm FSP (~200 m/s) than for the AP M2 ( $\leq 40$  m/s), confirming a trend that had been indicated in previous data.[2] The plate types that received no additional annealing treatment (C4 and S5) gave a performance comparable to similarly processed plate types that received an alpha-beta annealing treatment

Table 4. V<sub>50</sub> Ballistic Limit Results for the 20-mm FSP

Plate Type	Plate No.	Roll Direction	Roll Temp (°C)	Anneal Schedule	Thickness (mm)	Tested V <sub>50</sub> (m/s)	SD (m/s)	Required V <sub>50</sub> (m/s)
S1	313	Straight	954	788° C, 30 min, AC	25.32	957	7	949
C1	317	Cross	954	788° C, 30 min, AC	25.55	978	9	959
C2	318	Cross	954	1,038° C, 30 min, AC	25.55	775	15	959
C3	321	Cross	954	1,038° C, 30 min, AC	25.58	741	10	960
C4	322	Cross	954	788° C, 30 min, AC	25.60	984	7	961
C5	315	Cross	1,066	788° C, 30 min, AC	25.35	734	15	950
S2	303	Straight	1,066	788° C, 30 min, AC	25.27	757	7	947
S3	305	Straight	1,066	1,038° C, 30 min, AC	25.25	756	23	946
S4	306	Straight	1,066	1,038° C, 30 min, AC	25.17	734	10	943
S5	309	Straight	1,066	None	25.27	765	8	947
S6	311	Straight	1,066	STA 927° C, 30 min, WQ 538° C, 6 hrs, AC	25.43	784	4	953

Notes: AC = air cooled, STA = solution treat and aged, SD = standard deviation; WQ = water quenched.

Table 5.  $V_{50}$  Ballistic Limit Results for the 12.7-mm AP M2

Plate Type	Plate No.	Roll Direction	Roll Temp (°C)	Anneal Schedule	Thickness (mm)	Tested $V_{50}$ (m/s)	SD (m/s)	Required $V_{50}$ (m/s)
S1	312	Straight	954	788° C, 30 min, AC	25.35	700	8	681
C1	316	Cross	954	788° C, 30 min, AC	25.53	698	9	684
C2	319	Cross	954	1,038° C, 30 min, AC	25.63	657	10	686
C3	320	Cross	954	1,038° C, 30 min, AC	25.53	644	6	684
C4	323	Cross	954	788° C, 30 min, AC	25.60	700	6	686
C5	314	Cross	1,066	788° C, 30 min, AC	25.25	667	7	679
S2	302	Straight	1,066	788° C, 30 min, AC	25.27	675	10	680
S3	304	Straight	1,066	1,038° C, 30 min, AC	25.35	663	10	681
S4	307	Straight	1,066	1,038° C, 30 min, AC	25.17	650	11	678
S5	308	Straight	1,066	788° C, 30 min, AC	25.22	673	8	679
S6	310	Straight	1,066	STA 927° C, 30 min, WQ 538° C, 6 hrs, AC	25.12	645	7	677

Notes: AC = air cooled, STA = solution treat and aged, SD = standard deviation; WQ = water quenched.

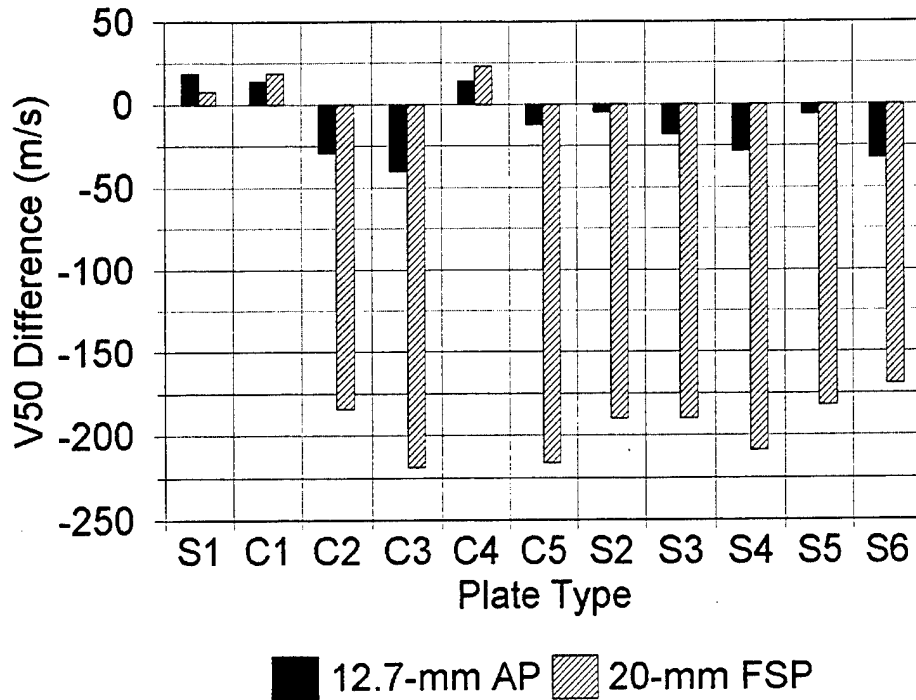

Figure 3.  $V_{50}$  Difference for Various Processing Conditions.

(C1 and S2). For the AP M2 evaluations, cross rolling provided no significant difference in  $V_{50}$  as compared to straight rolling (S1 versus C1 and C5 versus S2). For the 20-mm FSP evaluations, cross rolling seemed to provide a slightly higher  $V_{50}$  than straight rolling in the alpha-beta region (S1 versus C1); however, straight rolling seemed to be slightly better than cross rolling in the beta region (C5 versus S2).

For the 20-mm FSP, the large difference in the  $V_{50}$  limit velocities between the beta-processed and alpha-beta-processed plates tends to indicate that the failure mechanisms were in some way different. Observation of the rear plate surface failures upon perforating and near-perforating impacts showed this to be the case. The beta-processed plates failed by a process of adiabatic shear plugging, as shown in Figure 4. This plugging, a low energy failure mode that caused a titanium plug to be ejected from the rear surface of the plate after the FSP penetrated approximately 6 mm into the plate, has been described in previous work.[6,7,8] The plates that were alpha-beta processed failed by a mixed process of bulging, delaminating, shearing, and spalling, as shown in Figure 5. However, this failure occurred only after the FSP had penetrated approximately 15 mm into the plate, requiring the FSP to burrow significantly deeper into the armor than for the beta-processed plates.

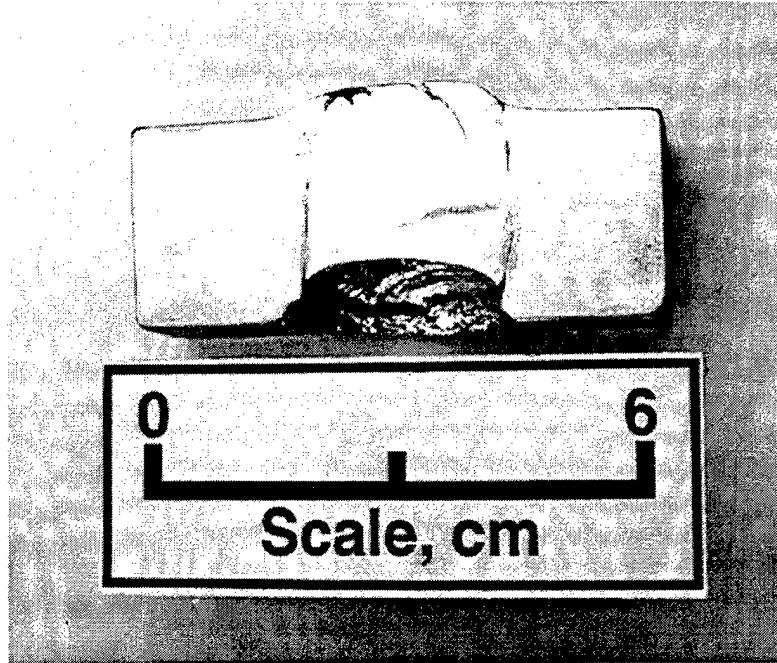

Figure 4. Cross Section of Impact Crater From 20-mm FSP for Beta-Processed Plate No. 315, Type C5, Shot No. 4065.

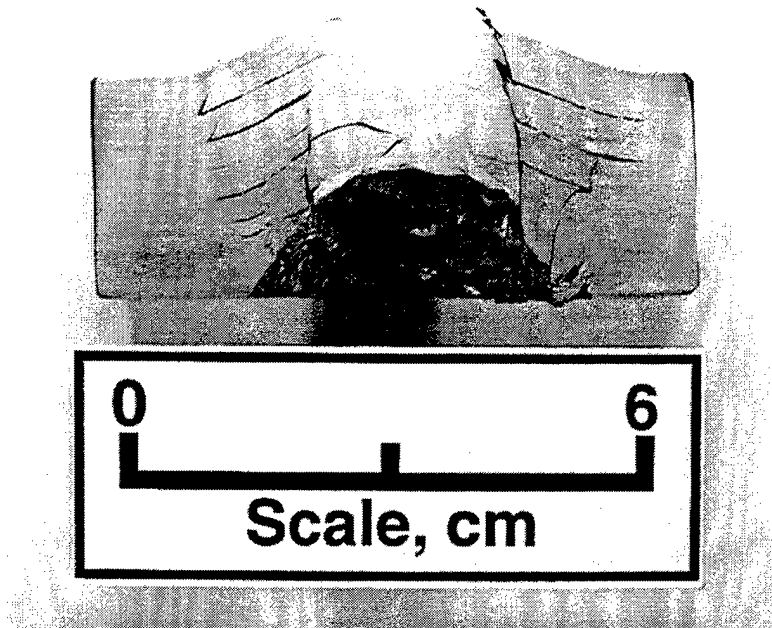

Figure 5. Cross Section of Impact Crater From 20-mm FSP for Alpha-Beta-Processed Plate No. 317, Type C1, Shot No. 4319.

Conversely, for the 12.7-mm AP M2, the relatively small differences in  $V_{50}$  performance between the beta- and alpha-beta-processed plates would seem to indicate little difference in the failure mechanisms. Again, observation of rear plate surface failures upon nearly perforating impacts confirmed this. The rear surface failure of a beta-processed plate (see Figure 6) looks remarkably similar to the rear surface failure of an alpha-beta-processed plate (see Figure 7). The failure mode for both the beta- and the alpha-beta-processed plates appeared to be a combination of bulging, petaling, and spalling.

After this battery of evaluations had been performed, some concerns arose about whether the surface oxide layer (alpha case) of the titanium plate was responsible for the large performance difference between the alpha-beta- and beta-processed plates. To determine if the alpha case caused the lower performance for the beta-processed plates, four plates (one alpha-beta processed and three beta processed) were selected and returned to ARC to be chemically milled (chem-milled) to remove the alpha case. Chem-milling is the controlled dissolution of a material through contact with a strong chemical reagent. The part to be processed is cleaned and then covered with a strippable, chemically resistant mask. The mask is stripped from areas where chemical action is desired, and then the part is submerged in the chemical reagent to dissolve the exposed material.[3]

Since these data showed that processing changes in titanium produce a greater change in  $V_{50}$  for the FSP than for the AP M2, the four plates (No. 303, 311, 315, and 322) were chosen from the plate population that had been tested with the FSP. After chem-milling, the plates were assigned new identification numbers (377, 378, 379, and 380, respectively) by ARC. These plates were then evaluated once again with the 20-mm FSP, and  $V_{50}$  ballistic limit velocities were determined. The data are given in Table 6. Note that chem-milling reduced the thickness of the plates and therefore also reduced the required  $V_{50}$  determined from MIL-A-46077D. The  $V_{50}$  differences, calculated with Equation (1), are plotted in Figure 8.

Three of the four plate conditions evaluated (C4, C5, and S2) showed an approximately 25-m/s increase in the  $V_{50}$  difference after chem-milling. For the fourth condition (S6), there was no statistically significant change in the  $V_{50}$  difference. Since the performance improvement occurred for both alpha-beta- and beta-processed plates (C4 and C5, respectively), the alpha case is not responsible for the large differences in  $V_{50}$ s obtained between alpha-beta- and beta-processed plates. Based on these results, chem-milling appears to provide a slight performance improvement over sand blasting. It is beyond the scope of this report to discuss the economics of sand blasting versus chem-milling.

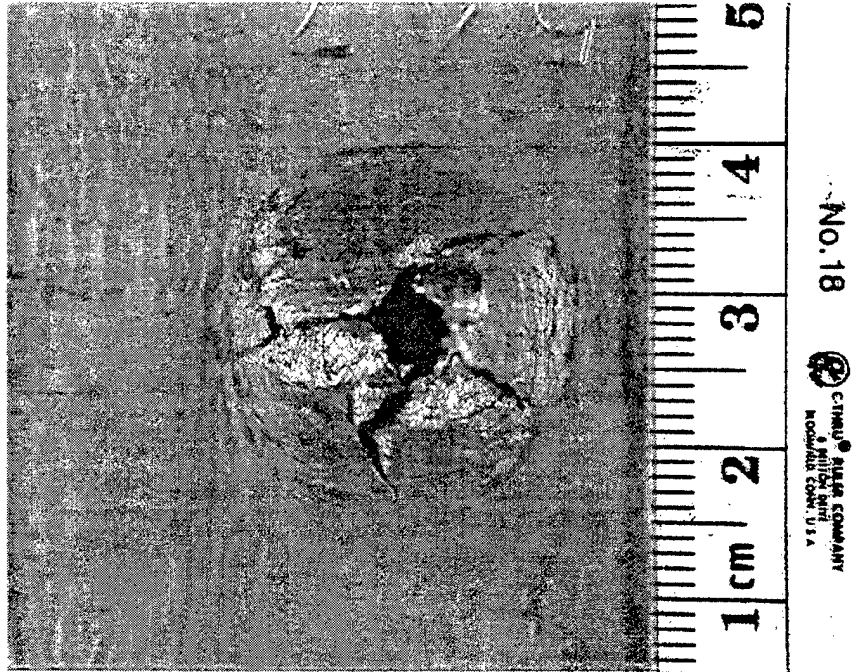

Figure 6. Rear Surface of Beta-Processed Plate No. 302, Type S2, Shot No. 5472 After a Nearly Perforating Impact by a 12.7-mm AP M2 Projectile.

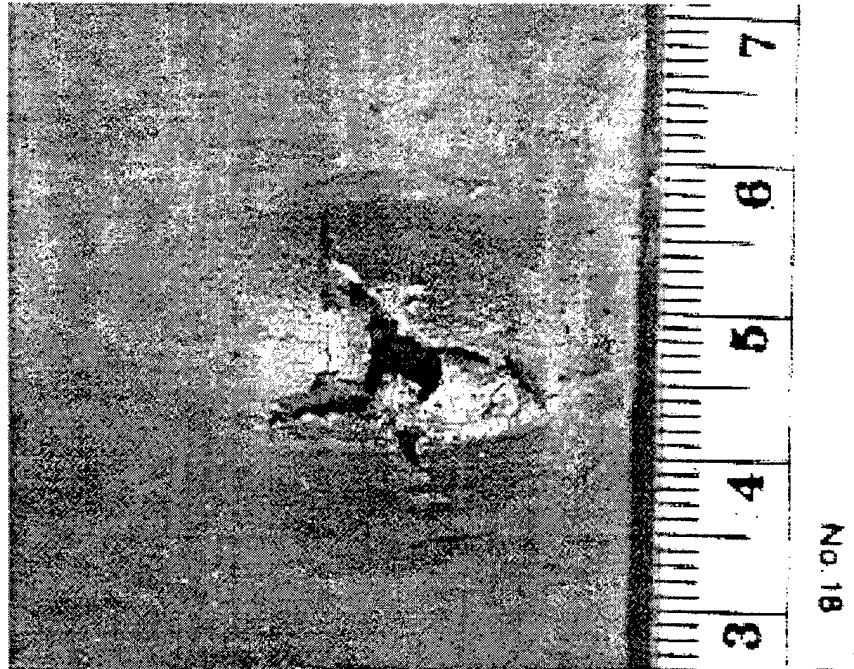

Figure 7. Rear Surface of Alpha-Beta-Processed Plate No. 312, Type S1, Shot No. 5450 After a Nearly Perforating Impact by a 12.7-mm AP M2 Projectile.

Table 6. Effect of Surface Finish on  $V_{50}$  Ballistic Limit for the 20-mm FSP

Plate Type	Thickness (mm)	As Received			Chem-milled			
		Tested $V_{50}$ (m/s)	SD (m/s)	Required $V_{50}$ (m/s)	Thickness (mm)	Tested $V_{50}$ (m/s)	SD (m/s)	Required $V_{50}$ (m/s)
S2	25.27	757	7	947	24.89	783	9	928
S6	25.43	784	4	953	24.94	756	18	930
C5	25.35	734	15	950	24.77	742	20	922
C4	25.60	984	7	961	25.25	995	10	945

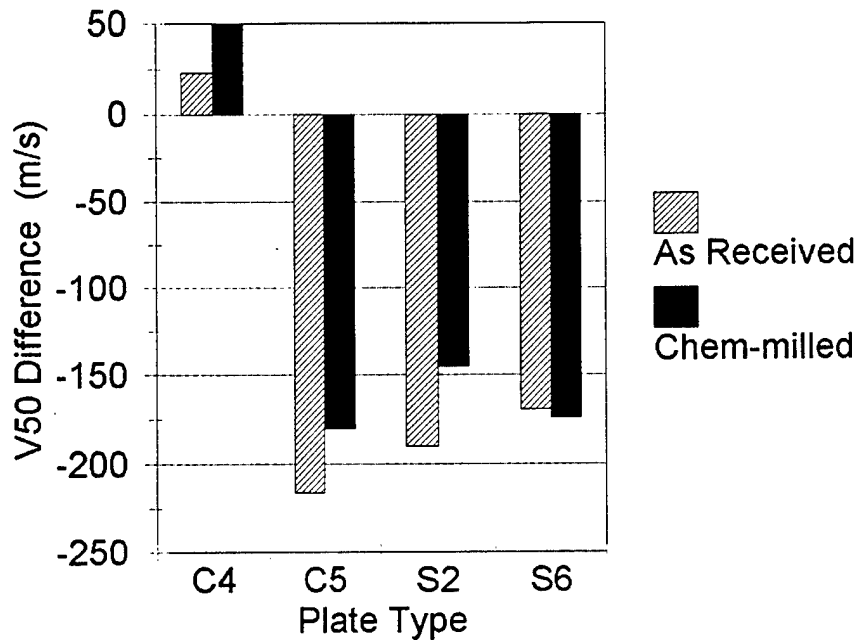

Figure 8. Effect of Surface Finish on  $V_{50}$  Difference for the 20-mm FSP.

## 7. Conclusions

Rolling or annealing at temperatures above the beta transus reduces the  $V_{50}$  ballistic limit velocity for both the 20-mm FSP and the 12.7-mm AP M2. The magnitude of the effect was much greater for the 20-mm FSP (~200 m/s) than for the AP M2 ( $\leq 40$  m/s), confirming a trend that had been indicated in previous data.[2] Of the three plates (S1, C1, and C4) that passed both the AP M2 and 20-mm FSP ballistic

requirements of MIL-A-46077D, two failed to meet the elongation requirements of MIL-A-46077D. In general, there was no correlation between adequate ballistic performance as required in MIL-A-46077D and ultimate tensile strength, yield strength, elongation, reduction in area, or Charpy impact energy. The plates that received no additional annealing treatment (C4 and S5) gave a performance comparable to similarly processed plates that received an alpha-beta anneal treatment (C1 and S2). Additionally, cross rolling versus straight rolling showed a small difference in  $V_{50}$  for the FSP but no significant difference in  $V_{50}$  for the AP M2.

The failure mode between the beta- and alpha-beta-processed plates was different for the 20-mm FSP. The beta-processed plates failed by a process of adiabatic shear plugging. This plugging, a low energy failure mode that occurred approximately 6 mm into the plate, has been described in previous work.[6,7,8] The alpha-beta-processed plates failed by a mixed process of bulging, delaminating, shearing, and spalling, which required more energy because the FSP had to burrow much deeper (~15 mm) into the armor plate before rear surface failure occurred. The failure mode for beta- and alpha-beta-processed plates appeared to be the same for the 12.7-mm AP M2. This observation is consistent with the relatively small differences in  $V_{50}$  performance between the beta- and alpha-beta-processed plates.

The removal of surface oxide layer (alpha case) by chem-milling did have an effect on the  $V_{50}$  ballistic limit of the plates when tested against the 20-mm FSP. No evaluation was performed with the 12.7-mm AP M2 since the data showed that processing changes in titanium produce a greater change in  $V_{50}$  for the FSP than for the AP M2. Of the four plate types that were chem-milled (C4, C5, S2, and S6), three plates (C4, C5, and S2) showed a  $V_{50}$  increase of approximately 25 m/s. The fourth plate (S6) did not show any statistically significant change in  $V_{50}$ . Since the performance improvement occurred for both alpha-beta- and beta-processed plates (C4 and C5, respectively), the alpha case is not responsible for the large differences in  $V_{50}$  data obtained between alpha-beta- and beta-processed plates. Based on these results, chem-milling may provide a slight performance improvement over sand blasting.

INTENTIONALLY LEFT BLANK

---

## References

---

1. Pitler, R., and A. Hurlich, "Some Mechanical and Ballistic Properties of Titanium and Titanium Alloys." WAL-TR-401/17, Watertown Arsenal Laboratory, MA, March 1950.
2. Sliney, J., "Status and Potential of Titanium Armor." *Proceedings of the Metallurgical Advisory Committee on Rolled Armor*. AMRA MS 64-04, U.S. Army Materials Research Agency, January 1964.
3. Donachie, M., "Titanium: A Technical Guide." ASM International, Metals Park, OH, 1989.
4. Grabarek, C., and E.L. Herr, "X-Ray Multi-Flash System for Measurement of Projectile Performance at the Target." BRL-TN-1634, U.S. Army Ballistic Research Laboratory, Aberdeen Proving Ground, MD, September 1966.
5. U.S. Army Test and Evaluation Command, "Ballistic Tests of Armor Materials." TOP-2-2-710 (AD A137873), Aberdeen Proving Ground, MD, 8 July 1993.
6. Burkins, M.S., W.W. Love, and J.R. Wood, "Effect of Annealing Temperature on the Ballistic Limit Velocity of Ti-6Al-4V ELI." ARL-MR-359, U.S. Army Research Laboratory, August 1997.
7. Corrigan, D., "Metallurgical Study of Titanium Alloy Armor, Part I- Ti-4Al-4V." WAL-TR-710.6/2 Pt. 1, Watertown Arsenal Laboratory, MA, January 1961.
8. Koepke, B., "Metallurgical Study of Back Spall Formation in Ti-6Al-4V Armor Plate." WAL-TN-710.6/3, Watertown Arsenal Laboratory, MA, February 1963.

INTENTIONALLY LEFT BLANK

APPENDIX A  
METALLOGRAPHIC ANALYSIS AND TENSILE TESTING DATA

INTENTIONALLY LEFT BLANK

## METALLOGRAPHIC ANALYSIS AND TENSILE DATA

Table A-1. Metallographic Analysis and Tensile Testing  
Data for Plate Nos. 302 and 303, Type S2

PLATE PROCESSING				
Initial Material	Forging	Rolling	Annealing	Finishing
RMI Titanium HT 854209/11 Annealed 5.062/5.125" thick	Step Forged @ 1950°F  5"- 4.25"- 3.5"	1950°F @ 300 in/min Start: 3.5" thick; End: 1.0" thick Straight Rolled in 8 passes (12% for 2 passes; 15% for 2 passes; 20% for 3 passes; 1 pass for final thickness)	Alpha-Beta  1450°F for 30 min, Air Cool	Sand-Blasted  300 BHN R <sub>C</sub> 30
MECHANICAL PROPERTIES				
Direction	UTS (ksi)	YS (ksi)	Elong (%)	RA (%)
Transverse	130.9	120.5	11.0	12.5
Transverse	131.5	121.5	10.8	12.5
Transverse	131.4	121.5	11.4	13.8
Transverse Avg	131.3	121.2	11.1	12.9
CHARPY IMPACT				
Direction	Test Temperature (°C)	Impact Velocity (fps)	Energy (ft-lb)	
TL	-40	12.02	21.42	
TL				
TL				
TL Avg	-40	12.02	21.42	
				
50X		500X		

Table A-2. Metallographic Analysis and Tensile Testing Data for Plate Nos. 304 and 305, Type S3

PLATE PROCESSING				
Initial Material	Forging	Rolling	Annealing	Finishing
RMI Titanium HT 854209/11 Annealed 5.062/5.125" thick	Step Forged @ 1950°F  5"- 4.25"- 3.5"	1950°F @ 300 in/min Start: 3.5" thick; End: 1.0" thick Straight Rolled in 8 passes (12% for 2 passes; 15% for 2 passes; 20% for 3 passes; 1 pass for final thickness)	Beta  1900°F for 30 min, Air Cool	Sand-Blasted  299 BHN R <sub>c</sub> 30
MECHANICAL PROPERTIES				
Direction	UTS (ksi)	YS (ksi)	Elong (%)	RA (%)
Transverse	133.2	118.3	8.5	18.3
Transverse	131.4	117.2	7.7	17.6
Transverse	132.8	118.1	8.1	17.8
Transverse Avg	132.5	117.9	8.1	17.9
CHARPY IMPACT				
Direction	Test Temperature (°C)	Impact Velocity (fps)	Energy (ft-lb)	
TL	-40	12.04	26.00	
TL	-40	12.03	24.69	
TL	-40	12.04	27.27	
TL Avg	-40	12.04	25.99	
				
50X		500X		

Table A-3. Metallographic Analysis and Tensile Testing Data for Plate Nos. 306 and 307, Type S4

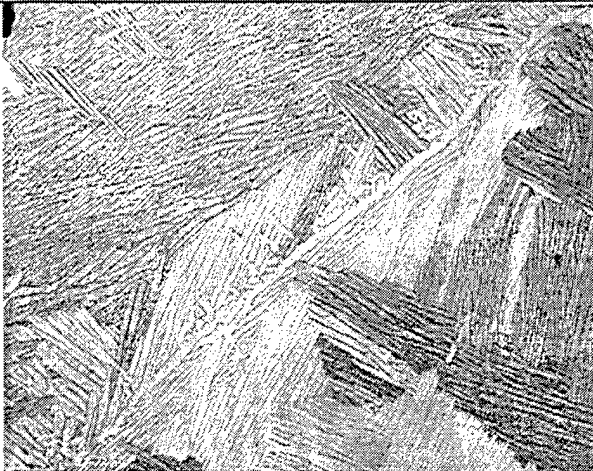

PLATE PROCESSING				
Initial Material	Forging	Rolling	Annealing	Finishing
RMI Titanium HT 854209/11 Annealed 5.062/5.125" thick	Step Forged @ 1950°F  5"- 4.25"- 3.5"	1950°F @ 300 in/min Start: 3.5" thick; End: 1.0" thick Straight Rolled in 8 passes (12% for 2 passes; 15% for 2 passes; 20% for 3 passes; 1 pass for final thickness)	Beta + Alpha-Beta 1900°F for 30 min, Air Cool + 1450°F for 30 min, Air Cool	Sand- Blasted  305 BHN R <sub>C</sub> 30
MECHANICAL PROPERTIES				
Direction	UTS (ksi)	YS (ksi)	Elong (%)	RA (%)
Transverse	131.8	122.3	8.4	17.8
Transverse	131.7	122.5	8.9	17.9
Transverse	130.4	121.8	No Data	16.2
Transverse Avg	131.3	122.2	8.7	17.3
CHARPY IMPACT				
Direction	Test Temperature (°C)	Impact Velocity (fps)	Energy (ft-lb)	
TL	-40	12.04	21.62	
TL	-40	12.03	19.16	
TL	-40	12.03	20.94	
TL Avg	-40	12.03	20.57	
				

Table A-4. Metallographic Analysis and Tensile Testing Data for Plate Nos. 308 and 309, Type S5

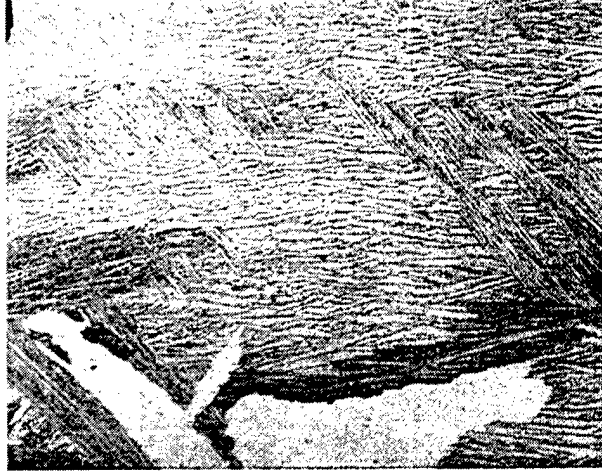
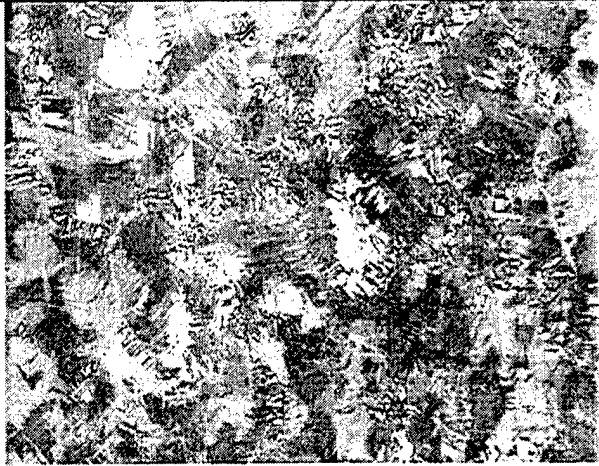

PLATE PROCESSING				
Initial Material	Forging	Rolling	Annealing	Finishing
RMI Titanium HT 854209/11 Annealed 5.062/5.125" thick	Step Forged @ 1950°F  5"- 4.25"- 3.5"	1950°F @ 300 in/min Start: 3.5" thick; End: 1.0" thick Straight Rolled in 8 passes (12% for 2 passes; 15% for 2 passes; 20% for 3 passes; 1 pass for final thickness)	None	Sand-Blasted  301 BHN R <sub>c</sub> 30
MECHANICAL PROPERTIES				
Direction	UTS (ksi)	YS (ksi)	Elong (%)	RA (%)
Transverse	132.7	118.8	10.3	21.1
Transverse	132.6	118.8	10.3	22.7
Transverse	133.0	118.9	9.8	22.8
Transverse Avg	132.8	118.8	10.1	22.2
CHARPY IMPACT				
Direction	Test Temperature (°C)	Impact Velocity (fps)	Energy (ft-lb)	
TL	-40	12.01	22.12	
TL	-40	12.03	22.59	
TL	-40	12.04	25.36	
TL Avg	-40	12.03	23.36	
				
50X		500X		

Table A-5. Metallographic Analysis and Tensile Testing Data for Plate Nos. 310 and 311, Type S6



PLATE PROCESSING				
Initial Material	Forging	Rolling	Annealing	Finishing
RMI Titanium HT 854209/11 Annealed 5.062/5.125" thick	Step Forged @ 1950°F  5"- 4.25"- 3.5"	1950°F @ 300 in/min Start: 3.5" thick; End: 1.0" thick Straight Rolled in 8 passes (12% for 2 passes; 15% for 2 passes; 20% for 3 passes; 1 pass for final thickness)	STA 1700°F for 30 min, Water Quench + 1000°F for 6 hrs, Air Cool	Sand-Blasted  327 BHN R <sub>c</sub> 33
MECHANICAL PROPERTIES				
Direction	UTS (ksi)	YS (ksi)	Elong (%)	RA (%)
Transverse	145.8	135.9	8.1	14.3
Transverse	142.0	132.5	8.7	17.1
Transverse	145.2	135.0	8.6	16.0
Transverse Avg	144.3	134.5	8.5	15.8
CHARPY IMPACT				
Direction	Test Temperature (°C)	Impact Velocity (fps)	Energy (ft-lb)	
TL	-40	12.03	21.96	
TL	-40	12.02	22.15	
TL	-40	12.01	22.83	
TL Avg	-40	12.02	22.31	
				
50X		500X		

Table A-6. Metallographic Analysis and Tensile Testing Data for Plate Nos. 312 and 313, Type S1

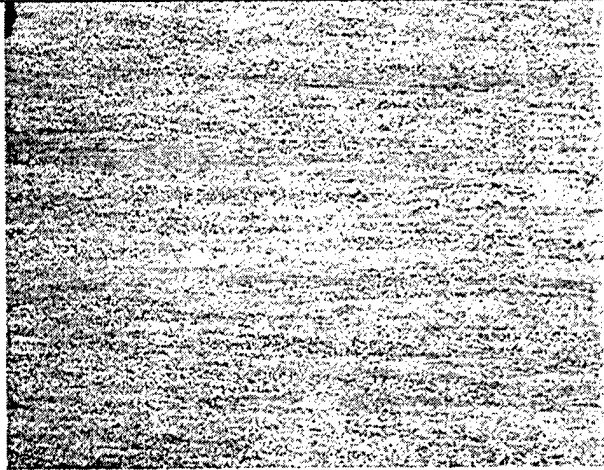

PLATE PROCESSING				
Initial Material	Forging	Rolling	Annealing	Finishing
RMI Titanium HT 854209/11 Annealed 5.062/5.125" thick	Step Forged @ 1750°F  5"- 4.25"- 3.5"	1750°F @ 300 in/min Start: 3.5" thick; End: 1.0" thick Straight Rolled in 8 passes (12% for 2 passes; 15% for 2 passes; 20% for 3 passes; 1 pass for final thickness)	Alpha-Beta  1450°F for 30 min, Air Cool	Sand-Blasted  292 BHN R <sub>C</sub> 29
MECHANICAL PROPERTIES				
Direction	UTS (ksi)	YS (ksi)	Elong (%)	RA (%)
Transverse	141.4	134.5	12.3	14.3
Transverse	140.6	133.6	12.9	17.1
Transverse	140.9	133.9	12.0	16.0
Transverse Avg	141.0	134.0	12.4	15.8
CHARPY IMPACT				
Direction	Test Temperature (°C)	Impact Velocity (fps)	Energy (ft-lb)	
TL	-40	12.03	26.21	
TL	-40	12.02	23.15	
TL	-40	12.01	22.90	
TL Avg	-40	12.02	24.09	
				
50X		500X		

Table A-7. Metallographic Analysis and Tensile Testing Data for Plate Nos. 314 and 315, Type C5

PLATE PROCESSING				
Initial Material	Forging	Rolling	Annealing	Finishing
RMI Titanium HT 854209/11 Annealed 5.062/5.125" thick	Step Forged @ 1950°F  5"- 4.25"- 3.5"	1950°F @ 300 in/min Start: 3.5" thick; End: 1.0" thick Cross Rolled in 8 passes (12% for 2 passes; 15% for 2 passes; 20% for 3 passes; 1 pass for final thickness)	Alpha-Beta  1450°F for 30 min, Air Cool	Sand-Blasted  304 BHN R <sub>C</sub> 30
MECHANICAL PROPERTIES				
Direction	UTS (ksi)	YS (ksi)	Elong (%)	RA (%)
Transverse	128.7	117.4	11.5	20.0
Transverse	128.4	117.6	11.9	22.6
Transverse	128.7	117.4	11.7	24.3
Transverse Avg	128.6	117.5	11.7	22.3
CHARPY IMPACT				
Direction	Test Temperature (°C)	Impact Velocity (fps)	Energy (ft-lb)	
TL	-40	12.02	20.42	
TL	-40	12.03	22.66	
TL	-40	12.03	24.67	
TL Avg	-40	12.03	22.58	
				
50X		500X		

Table A-8. Metallographic Analysis and Tensile Testing Data for Plate Nos. 316 and 317, Type C1

PLATE PROCESSING				
Initial Material	Forging	Rolling	Annealing	Finishing
RMI Titanium HT 854209/11 Annealed 5.062/5.125" thick	Step Forged @ 1750°F  5"- 4.25"- 3.5"	1750°F @ 300 in/min Start: 3.5" thick; End: 1.0" thick Cross Rolled in 8 passes (12% for 2 passes; 15% for 2 passes; 20% for 3 passes; 1 pass for final thickness)	Alpha-Beta  1450°F for 30 min, Air Cool	Sand-Blasted  299 BHN R <sub>c</sub> 30
MECHANICAL PROPERTIES				
Direction	UTS (ksi)	YS (ksi)	Elong (%)	RA (%)
Transverse	140.8	134.7	15.0	31.8
Transverse	139.7	134.0	12.9	30.3
Transverse	140.1	134.2	13.2	38.2
Transverse Avg	140.2	134.3	13.7	33.4
CHARPY IMPACT				
Direction	Test Temperature (°C)	Impact Velocity (fps)	Energy (ft-lb)	
TL	-40	12.03	24.90	
TL	-40	12.03	21.08	
TL	-40	12.03	21.78	
TL Avg	-40	12.03	22.59	
				
50X		500X		

Table A-9. Metallographic Analysis and Tensile Testing Data for Plate Nos. 318 and 319, Type C2

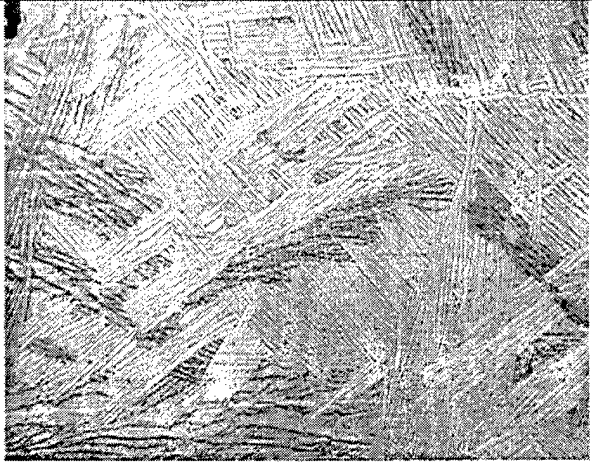

PLATE PROCESSING				
Initial Material	Forging	Rolling	Annealing	Finishing
RMI Titanium HT 854209/11 Annealed 5.062/5.125" thick	Step Forged @ 1750°F  5"- 4.25"- 3.5"	1750°F @ 300 in/min Start: 3.5" thick; End: 1.0" thick Cross Rolled in 8 passes (12% for 2 passes; 15% for 2 passes; 20% for 3 passes; 1 pass for final thickness)	Beta  1900°F for 30 min, Air Cool	Sand-Blasted  296 BHN R <sub>C</sub> 29
MECHANICAL PROPERTIES				
Direction	UTS (ksi)	YS (ksi)	Elong (%)	RA (%)
Transverse	133.5	118.8	10.3	18.8
Transverse	132.7	117.6	10.5	23.4
Transverse	133.5	118.9	10.4	16.6
Transverse Avg	133.2	118.4	10.4	19.6
CHARPY IMPACT				
Direction	Test Temperature (°C)	Impact Velocity (fps)	Energy (ft-lb)	
TL	-40	12.03	21.43	
TL	-40	12.02	23.02	
TL	-40	12.03	23.12	
TL Avg	-40	12.03	22.52	
				

Table A-10. Metallographic Analysis and Tensile Testing Data for Plate Nos. 320 and 321, Type C3

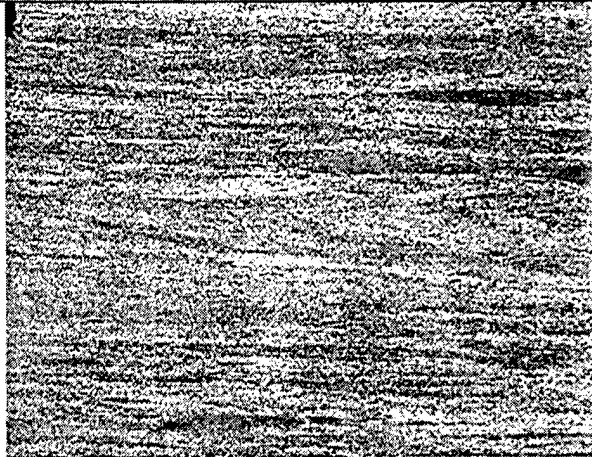
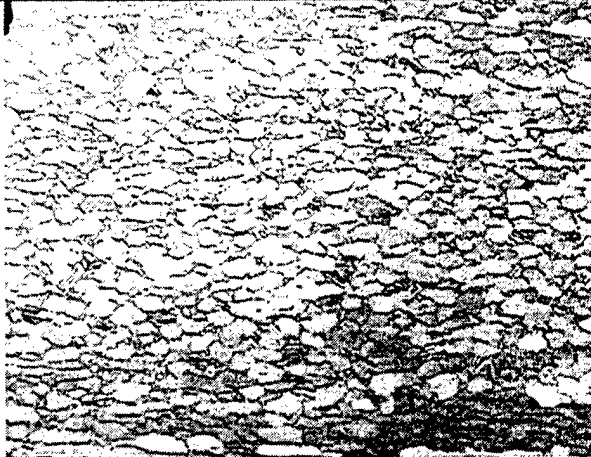

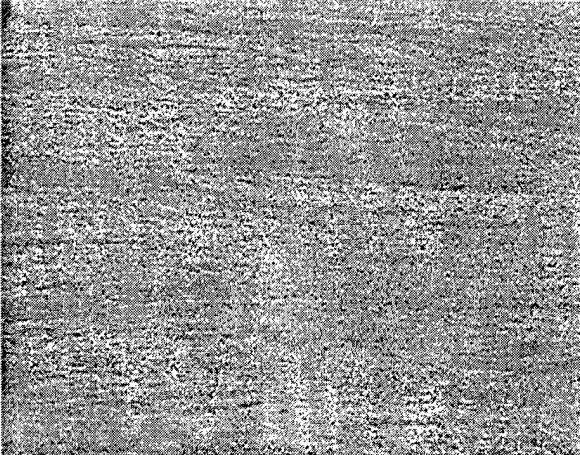

PLATE PROCESSING				
Initial Material	Forging	Rolling	Annealing	Finishing
RMI Titanium HT 854209/11 Annealed 5.062/5.125" thick	Step Forged @ 1750°F  5"- 4.25"- 3.5"	1750°F @ 300 in/min Start: 3.5" thick; End: 1.0" thick Cross Rolled in 8 passes (12% for 2 passes; 15% for 2 passes; 20% for 3 passes; 1 pass for final thickness)	Beta + Alpha-Beta 1900°F for 30 min, Air Cool + 1450°F for 30 min, Air Cool	Sand-Blasted  297 BHN R <sub>C</sub> 29
MECHANICAL PROPERTIES				
Direction	UTS (ksi)	YS (ksi)	Elong (%)	RA (%)
Transverse	132.3	122.8	10.4	21.6
Transverse	131.5	121.7	10.9	20.9
Transverse	131.9	121.9	10.3	19.2
Transverse Avg	131.9	122.1	10.5	20.6
CHARPY IMPACT				
Direction	Test Temperature (°C)	Impact Velocity (fps)	Energy (ft-lb)	
TL	-40	12.03	18.65	
TL	-40	12.02	19.65	
TL	-40	12.04	18.58	
TL Avg	-40	12.03	18.96	
				
50X		500X		

Table A-11. Metallographic Analysis and Tensile Testing Data for Plate Nos. 322 and 323, Type C4

PLATE PROCESSING				
Initial Material	Forging	Rolling	Annealing	Finishing
RMI Titanium HT 854209/11 Annealed 5.062/5.125" thick	Step Forged @ 1750°F  5"- 4.25"- 3.5"	1750°F @ 300 in/min Start: 3.5" thick; End: 1.0" thick Cross Rolled in 8 passes (12% for 2 passes; 15% for 2 passes; 20% for 3 passes; 1 pass for final thickness)	None	Sand-Blasted  310 BHN R <sub>c</sub> 34
MECHANICAL PROPERTIES				
Direction	UTS (ksi)	YS (ksi)	Elong (%)	RA (%)
Transverse	142.9	135.8	13.4	34.4
Transverse	144.0	136.6	13.9	28.9
Transverse	143.3	136.1	15.3	29.3
Transverse Avg	143.4	136.2	14.2	30.9
CHARPY IMPACT				
Direction	Test Temperature (°C)	Impact Velocity (fps)	Energy (ft-lb)	
TL	-40	12.03	33.08	
TL	-40	12.03	32.46	
TL	-40	12.03	35.79	
TL Avg	-40	12.03	33.78	
				

INTENTIONALLY LEFT BLANK.

APPENDIX B  
BALLISTIC DATA

INTENTIONALLY LEFT BLANK.

## List of Abbreviations Used in This Appendix

- Not applicable.
- CP Complete penetration; penetrator or target material exits the rear surface of the target. Asterisks (\*CP\*) indicate shots that were used to calculate the  $V_{50}$ .
- $\Delta W$  The mass loss in a plate caused by a shot. Mass of plate prior to shot minus the mass of plate after the shot.
- $L_R$  Residual length; the length of residual penetrator or the thickness of a target material for a CP result.
- $M_R$  Residual mass; the mass of residual penetrator or target material for a CP result.
- NM Not measured.
- PIP Penetrator in plate; penetrator lodged in impact crater.
- PP Partial penetration; the penetrator is defeated by the target. Asterisks (\*PP\*) indicate shots that were used to calculate the  $V_{50}$ .
- $P_R$  Penetration into plate; the impact crater depth.
- RES Result of shot; CP or PP.
- $V_R$  Residual velocity; the velocity measured behind the target when a CP result occurs. The "COMMENTS" column defines whether this velocity is for penetrator or target material.
- $V_S$  Striking velocity of projectile just prior to impacting the target.
- YAW Total yaw; the vector sum of vertical pitch and horizontal yaw for the projectile.

INTENTIONALLY LEFT BLANK.

Table B-1. Firing Data for 12.7-mm AP M2 Versus Plate No. 302, Type S2, at 0° Obliquity  
(Str. Roll @ 1,066° C; Anneal @ 788° C, 30 min., AC; 25.27 mm thick; 302-BHN hardness)

Shot No.	V <sub>s</sub> (m/s)	YAW (°)	RES	V <sub>R</sub> (m/s)	L <sub>R</sub> (mm)	M <sub>R</sub> (g)	P <sub>R</sub> (mm)	ΔW (g)	Comments
5468	661	1.50	*PP*	—	—	—	29.5	3.7	5-mm bulge w/cracks
5469	665	0.71	*PP*	—	—	—	31	4.5	4-mm bulge w/cracks
5470	676	1.60	*CP*	47	3	NM	—	9.5	Spall
5472	677	0.56	*PP*	—	—	—	32	6.8	7-mm bulge w/cracks
5467	685	1.25	*CP*	44	3	NM	—	6.2	Spall
5471	688	0.35	*CP*	56	3.9	1.1	PIP	-17.8	Spall
5466	701	0.56	CP	154 85	47.2 4.9	25.4 3.6	—	15.9	Penetrator Spall

Table B-2. Firing Data for 20-mm FSP Versus Plate No. 303, Type S2, at 0° Obliquity  
(Str. Roll @ 1,066° C; Anneal @ 788° C, 30 min., AC; 25.27 mm thick; 302-BHN hardness)

Shot No.	V <sub>s</sub> (m/s)	YAW (°)	RES	V <sub>R</sub> (m/s)	L <sub>R</sub> (mm)	M <sub>R</sub> (g)	P <sub>R</sub> (mm)	ΔW (g)	Comments
4095	745	1.12	PP	—	—	6	6	6.9	3-mm bulge
4089	748	0.71	*PP*	—	—	6.5	6.5	2.6	4-mm bulge w/cracks
4094	750	0.79	*PP*	—	—	8	8	4.0	5-mm bulge/plug formed
4093	755	0.75	*CP*	79	2	NM	—	5.6	4x5-mm Chip
4096	756	1.52	*PP*	—	—	8	9	3.4	5-mm bulge/plug formed
4098	761	2.30	*CP*	48	3	NM	—	-1.6	10x5-mm Chip
4097	770	1.80	*CP*	75	2	NM	—	3.5	6x5-mm Chip
4092	774	0.56	CP	79	2.6	0.1	—	4.1	6x5-mm Chip
4091	799	0.75	CP	27 55	16.4 24.1	48.8 58.8	—	63.5	Penetrator Plug
4090	848	0.50	CP	55 119	15.9 20.5	46.1 35.4	—	61.5	Penetrator Plug
4088	1,153	0.56	CP	293 369	17.4 23.2	NM NM	—	95.8	Penetrator Plug

Table B-3. Firing Data for 12.7-mm AP M2 Versus Plate No. 304, Type S3, at 0° Obliquity  
(Str. Roll @ 1,066° C; Anneal @ 1,038° C, 30 min., AC; 25.35 mm thick; 302- BHN hardness)

Shot No.	V <sub>S</sub> (m/s)	YAW (°)	RES	V <sub>R</sub> (m/s)	L <sub>R</sub> (mm)	M <sub>R</sub> (g)	P <sub>R</sub> (mm)	ΔW (g)	Comments
5509	640	0.5	PP	—	—	—	27	6.4	4-mm bulge w/cracks
5512	653	0.25	*PP*	—	—	—	29	4.3	7-mm bulge w/cracks
5510	655	2.46	*PP*	—	—	—	27	4.3	5-mm bulge w/cracks
5507	657	0.75	*CP*	31	5.1	2.2	29	7.4	Spall
5511	659	2.55	*PP*	—	—	—	26	4.9	5-mm bulge w/crack
5514	676	0.71	*CP*	148	4.9	1.9	PIP	-13.2	Spall
5513	677	0.25	*CP*	33	6.0	4.1	—	8.8	Spall
5506	698	1.12	CP	70 106	47.3 4	25.3 NM	—	10.6	Penetrator Spall

Table B-4. Firing Data for 20-mm FSP Versus Plate No. 305, Type S3, at 0° Obliquity  
(Str. Roll @ 1,066° C; Anneal @ 1,038° C, 30 min., AC; 25.25 mm thick; 311- BHN hardness)

Shot No.	V <sub>S</sub> (m/s)	YAW (°)	RES	V <sub>R</sub> (m/s)	L <sub>R</sub> (mm)	M <sub>R</sub> (g)	P <sub>R</sub> (mm)	ΔW (g)	Comments
4352	698	0.00	PP	—	—	—	6	4.2	4-mm bulge w/cracks
4356	713	2.24	PP	—	—	—	7	2.6	4-mm bulge w/cracks
4357	715	1.03	PP	—	—	—	6	2.7	4-mm bulge w/cracks
4355	715	1.68	PP	—	—	—	6	2.9	3-mm bulge w/cracks
4358	722	1.68	PP	—	—	—	6	2.3	3-mm bulge w/cracks
4354	722	1.35	*CP*	82	1.8	<0.01	6.5	7.0	3x2-mm chip
4362	727	1.77	PP	—	—	—	6	3.1	Plug pushed out 2mm
4359	738	2.85	*PP*	—	—	—	7	4.4	3-mm bulge w/cracks
4360	738	2.50	*CP*	108	5.9	0.25	6.5	2.8	8x5-mm chip
4361	739	2.02	*PP*	—	—	—	7	3.9	4-mm bulge w. cracks
4353	745	2.37	*CP*	70	2.7	0.28	7.5	3.2	11x5-mm chip
4380	760	1.77	*PP*	—	—	—	8	4.1	Plug pushed out 2mm
4385	765	1.77	*CP*	121	1	NM	8	4.2	4x3-mm chip
4386	766	1.35	*PP*	—	—	—	8	3.9	5-mm bulge w/cracks
4388	789	0.56	*PP*	—	—	—	8	4.2	6-mm bulge w/cracks
4389	797	0.79	*CP*	127	3.8	0.07	13	5.7	5x2-mm chip
4351	909	0.75	CP	173 210	15.7 21.0	44.6 36.5	—	68.6	Penetrator Plug
4350	1,052	0.00	CP	279 336	13.1 22.0	42.5 48.6	—	86.8	Penetrator Plug

Table B-5. Firing Data for 20-mm FSP Versus Plate No. 306, Type S4, at 0° Obliquity  
(Str. Roll @ 1,066° C; Anneal @ 1,038° C, 30 min., AC, followed by Anneal @788° C, 30 min, AC; 25.17 mm thick; 311-BHN hardness)

Shot No.	V <sub>s</sub> (m/s)	YAW (°)	RES	V <sub>R</sub> (m/s)	L <sub>R</sub> (mm)	M <sub>R</sub> (g)	P <sub>R</sub> (mm)	ΔW (g)	Comments
4364	706	1.00	PP	—	—	—	5.5	2.9	2-mm bulge w/cracks
4366	721	1.12	*PP*	—	—	—	6	3.4	4-mm bulge w/cracks
4367	725	1.46	*PP*	—	—	—	6	6.5	4-mm bulge w/cracks
4370	732	1.25	*CP*	18	1	NM	8	3.0	6x4-mm chip
4368	734	1.46	*CP*	47	2	NM	7	3.6	7x4-mm chip
4369	742	0.79	*PP*	—	—	—	9	3.5	Plug pushed out 4mm
4365	749	1.60	*CP*	90	2.7	0.13	8	4.0	6x4-mm chip
4379	762	1.77	CP	135	1	NM	9	3.7	7x2-mm chip
4363	905	2.80	CP	127 224	16.3 21.0	44.2 39.9	—	67.4	Penetrator Plug

Table B-6. Firing Data for 12.7-mm AP M2 Versus Plate No. 307, Type S4, at 0° Obliquity  
(Str. Roll @ 1,066° C; Anneal @ 1,038° C, 30 min., AC, followed by Anneal @788° C, 30 min, AC; 25.17 mm thick; 302-BHN hardness)

Shot No.	V <sub>s</sub> (m/s)	YAW (°)	RES	V <sub>R</sub> (m/s)	L <sub>R</sub> (mm)	M <sub>R</sub> (g)	P <sub>R</sub> (mm)	ΔW (g)	Comments
5521	618	0.25	PP	—	—	—	24	17.2	3-mm bulge w/cracks
5522	637	1.03	*PP*	—	—	—	28	5.4	5-mm bulge w/crack
5525	640	0.25	*PP*	—	—	—	29.0	5.2	7-mm bulge w/cracks
5523	641	1.03	*PP*	—	—	—	27	3.9	4-mm bulge w/cracks
5520	660	2.50	*CP*	42	4.8	1.4	N/A	-18.9	Spall
5524	660	1.03	*CP*	88	4.5	1.0	N/A	6.9	Spall
5519	661	1.77	*CP*	113	5	NM	N/A	6.9	Spall
5517	665	0.35	CP	35	5.1	1.9	N/A	7.4	Spall
5518	696	4.24	CP	45 158	47.3 4	25.4 NM	N/A	12.2	Penetrator Spall
5515	699	3.76	CP	>163	4.7	2.9	N/A	-13.8	Spall

Table B-7. Firing Data for 12.7-mm AP M2 Versus Plate No. 308, Type S5, at 0° Obliquity  
(Str. Roll @ 1,066° C; No Anneal; 25.22 mm thick; 302-BHN hardness)

Shot No.	V <sub>s</sub> (m/s)	YAW (°)	RES	V <sub>R</sub> (m/s)	L <sub>R</sub> (mm)	M <sub>R</sub> (g)	P <sub>R</sub> (mm)	ΔW (g)	Comments
5474	660	2.14	*PP*	—	—	—	29	5.0	4-mm bulge w/cracks
5478	668	0.75	*CP*	50	5	NM	—	6.8	Spall
5476	671	1.52	*PP*	—	—	—	27.5	3.9	6-mm bulge w/cracks
5479	672	0.56	*PP*	—	—	—	31	4.2	Spall pushed out 3mm
5477	680	2.02	*CP*	36	5.0	4.7	PIP	-14.1	Spall
5475	685	0.71	*CP*	57	4.8	3.8	—	14.3	Spall
5473	699	1.46	CP	21	5.9	1.8	PIP	-17.5	Spall

Table B-8. Firing Data for 20-mm FSP Versus Plate No. 309, Type S5, at 0° Obliquity  
(Str. Roll @ 1,066° C; No Anneal; 25.27 mm thick; 311-BHN hardness)

Shot No.	V <sub>s</sub> (m/s)	YAW (°)	RES	V <sub>R</sub> (m/s)	L <sub>R</sub> (mm)	M <sub>R</sub> (g)	P <sub>R</sub> (mm)	ΔW (g)	Comments
4372	703	1.46	PP	—	—	—	5	3.0	3-mm bulge w/cracks
4382	735	0.56	PP	—	—	—	7	3.4	3.5-mm bulge w/cracks
4373	753	0.90	*PP*	—	—	—	7	4.3	4-mm bulge w/cracks
4378	757	2.02	*PP*	—	—	—	7	4.9	5-mm bulge w/cracks
4375	763	2.15	*PP*	—	—	—	8	3.8	Plug pushed out 2mm
4376	767	1.46	*CP*	79	3.5	0.45	9	4.3	14x7-mm chip
4377	768	2.02	*CP*	141	1	NM	7.5	3.2	3x3-mm chip
4374	779	2.02	*CP*	122	3.1	0.38	9	4.3	10x8-mm chip
4384	781	1.77	*PP*	—	—	—	9	1.9	5-mm bulge w/cracks
4383	783	0.71	*CP*	60	1	NM	10	7.1	11x5-mm chip
4387	799	1.00	*CP*	77	2.7	0.16	11	7.3	8x-7mm chip
4381	803	1.12	*PP*	—	—	—	14.5	3.6	Plug pushed out 10mm
4371	947	0.71	CP	155 235	15.5 16.2	47.2 37.9	—	86.0	Penetrator Plug

Table B-9. Firing Data for 12.7-mm AP M2 Versus Plate No. 310, Type S6, at 0° Obliquity  
(Str. Roll @ 1,066° C; STA @ 927° C, 30 min, WQ, followed by Anneal @ 538° C, 6 hrs, AC; 25.12 mm thick;  
321-BHN hardness)

Shot No.	V <sub>S</sub> (m/s)	YAW (°)	RES	V <sub>R</sub> (m/s)	L <sub>R</sub> (mm)	M <sub>R</sub> (g)	P <sub>R</sub> (mm)	ΔW (g)	Comments
5426	632	0.56	PP	—	—	—	24.5	3.6	3-mm bulge w/cracks
5425	633	1.00	*PP*	—	—	—	25.5	5.2	3-mm bulge w/cracks
5414	647	2.85	*PP*	—	—	—	27.0	5.0	4.5-mm bulge w/cracks
5429	649	3.16	*CP*	89	4.9	2.3	N/A	-3.2	Spall
5428	650	2.70	*CP*	Lost	4.4	1.7	N/A	-1.6	Spall
5427	661	1.75	CP	15	4.2	1.7	N/A	5.8	Spall
5413	671	0.50	CP	88	4.0	2.6	N/A	-14.9	Spall
5417	675	1.77	CP	56	4.0	1.8	N/A	10.2	Spall
5418	676	3.76	CP	158	4.6	1.2	N/A	-1.3	Spall
5424	690	0.75	CP	75	47.1	25.5	N/A	11.3	Penetrator
5412	713	5.35	CP	139	4.9	1.8	N/A	5.4	Spall
5410	718	1.46	CP	145	47.3	25.3	N/A	12.8	Penetrator

Table B-10. Firing Data for 20-mm FSP Versus Plate No. 311, Type S6, at 0° Obliquity  
(Str. Roll @ 1,066° C; STA @ 927° C, 30 min, WQ, followed by Anneal @ 538° C, 6 hrs, AC; 25.43 mm thick;  
321-BHN hardness)

Shot No.	V <sub>S</sub> (m/s)	YAW (°)	RES	V <sub>R</sub> (m/s)	L <sub>R</sub> (mm)	M <sub>R</sub> (g)	P <sub>R</sub> (mm)	ΔW (g)	Comments
4082	746	0.79	PP	—	—	—	6	1.9	3-mm bulge w/plug formed
4083	778	0.71	*PP*	—	—	—	7	-2.6	4-mm bulge w/plug formed
4099	781	1.27	*CP*	36	1	NM	—	8.0	4x2-mm spall
4087	782	0.35	*CP*	69	3	NM	—	5.2	20x8-mm spall
4085	785	0.71	*PP*	—	—	—	9	14.2	5-mm bulge w/plug formed
4101	788	1.80	*PP*	—	—	—	8	6.8	4-mm bulge w/cracks
4100	791	2.36	*CP*	LOST	18.8	38.5	—	41.9	Plug
4084	799	0.56	CP	80	1	NM	—	16.8	8x3-mm spall
4086	808	0.90	CP	97	2	NM	—	-5.5	8x9-mm spall
4081	859	0.71	CP	75 134	16.1 19.8	46.9 56.8	—	83.0	Penetrator Plug
4080	1,164	1.27	CP	309 388	14.9 23	30.9 NM	—	117.8	Penetrator Plug

Table B-11. Firing Data for 12.7-mm AP M2 Versus Plate No. 312, Type S1, at 0° Obliquity  
(Str. Roll @ 954° C; Anneal @ 788° C, 30 min, AC; 25.35 mm thick; 302-BHN hardness)

Shot No.	V <sub>S</sub> (m/s)	YAW (°)	RES	V <sub>R</sub> (m/s)	L <sub>R</sub> (mm)	M <sub>R</sub> (g)	P <sub>R</sub> (mm)	ΔW (g)	Comments
5453	682	2.30	PP	—	—	—	33	3.7	8-mm bulge w/cracks
5444	689	1.52	*PP*	—	—	—	PIP	-20.2	Tip protruding 4mm
5450	693	1.58	*PP*	—	—	—	32	4.3	6-mm bulge w/cracks
5455	696	3.88	*CP*	39	4.6	1.7	—	-18.6	Spall
5452	701	1.35	*CP*	82 44	47.0 3.5	25.4 2.0	—	7.2	Penetrator Spall
5449	708	1.95	*CP*	87 25	47.2 6.1	25.4 2.7	—	8.6	Penetrator Spall
5446	711	2.61	*PP*	—	—	—	PIP	-20.9	Tip protruding 4mm
5448	718	2.15	CP	135 40	46.9 4.1	25.3 2.6	—	11.2	Penetrator Spall
5451	718	2.61	CP	65 47	47.4 4.0	25.3 2.1	—	7.8	Penetrator Spall
5447	724	0.75	CP	206 109	47.2 3.9	25.3 1.8	—	9.5	Penetrator Spall

Table B-12. Firing Data for 20-mm FSP Versus Plate No. 313, Type S1, at 0° Obliquity  
(Str. Roll @ 954° C; Anneal @ 788° C, 30 min, AC; 25.32 mm thick; 302-BHN hardness)

Shot No.	V <sub>S</sub> (m/s)	YAW (°)	RES	V <sub>R</sub> (m/s)	L <sub>R</sub> (mm)	M <sub>R</sub> (g)	P <sub>R</sub> (mm)	ΔW (g)	Comments
4304	895	1.12	PP	—	—	—	11	8.9	11-mm bulge w/spall disk 90% formed
4308	931	0.75	PP	—	—	—	12.5	11.7	6-mm bulge w/cracks
4307	939	1.03	PP	—	—	—	14	27.1	9-mm bulge w/spall disk 75% formed
4311	948	0.75	*PP*	—	—	—	20	18.2	Spall disk formed & pushed out 16mm
4306	950	0.56	*CP*	46	21.8	117.6	—	137.1	Spall
4312	952	0.50	*CP*	43	16.5	76.6	—	213.7	Spall
4313	962	0.35	*PP*	—	—	—	23	23.0	Spall disk formed & pushed out 13mm
4314	962	2.55	*PP*	—	—	—	14	16.8	7-mm bulge w/cracks
4315	968	1.41	*CP*	92	15.8	50.3	—	89.9	Spall
4305	1,017	0.71	CP	99	16.6	59.1	—	108.8	Spall
4303	1,145	0.56	CP	278 300	14.0 17.0	37.0 26.6	—	107.3	Penetrator Spall

Table B-13. Firing Data for 12.7-mm AP M2 Versus Plate No. 314, Type C5, at 0° Obliquity  
(Cross Roll @ 1,066° C; Anneal @ 788° C, 30 min, AC; 25.25 mm thick; 302-BHN hardness)

Shot No.	V <sub>S</sub> (m/s)	YAW (°)	RES	V <sub>R</sub> (m/s)	L <sub>R</sub> (mm)	M <sub>R</sub> (g)	P <sub>R</sub> (mm)	ΔW (g)	Comments
5406	593	0.56	PP	—	—	—	22	4.1	2-mm bulge w/cracks
5404	612	1.25	PP	—	—	—	24	4.6	3-mm bulge w/cracks
5407	623	1.06	PP	—	—	—	24	3.1	3-mm bulge w/cracks
5403	637	1.25	PP	—	—	—	26.5	4.4	4.5-mm bulge w/cracks
5432	657	1.25	*PP*	—	—	—	22.5	3.4	4-mm bulge w/cracks
5430	664	1.25	*PP*	—	—	—	27	2.8	5-mm bulge w/cracks
5431	672	1.35	*CP*	78	6.6	4.0	—	-17.6	Spall
5433	675	3.01	*CP*	70	4.8	1.3	—	5.6	Spall
5401	687	4.25	CP	121	8	NM	—	9.1	Spall
5409	698	3.75	CP	74	5.9	4.1	—	9.3	Spall
5402	702	3.95	CP	49	24.2	9.8	—	8.9	Penetrator
5405	705	2.02	CP	147	26.4	13.0	—	-0.3	Penetrator
5408	729	1.52	CP	201	47	NM	—	10.8	Penetrator

Table B-14. Firing Data for 20-mm FSP Versus Plate No. 315, Type C5, at 0° Obliquity  
(Cross Roll @ 1,066° C; Anneal @ 788° C, 30 min, AC; 25.35 mm thick; 321-BHN hardness)

Shot No.	V <sub>S</sub> (m/s)	YAW (°)	RES	V <sub>R</sub> (m/s)	L <sub>R</sub> (mm)	M <sub>R</sub> (g)	P <sub>R</sub> (mm)	ΔW (g)	Comments
4114	711	1.80	*PP*	—	—	—	5.5	-0.8	3-mm bulge/plug formed
4113	713	2.30	*PP*	—	—	—	6.5	10.7	4-mm bulge/plug formed
4112	719	0.90	*CP*	83	2	NM	—	4.9	4x4-mm chip
4111	726	1.80	*CP*	22	3	NM	—	0.1	9x10-mm chip
4107	736	1.25	*PP*	—	—	—	7.5	-2.6	4-mm bulge/plug formed
4106	740	2.12	*CP*	48	2.7	0.3	—	7.7	12x5-mm chip
4110	743	0.90	*PP*	—	—	—	7.5	-0.3	4mm bulge/plug formed
4108	745	0.56	*CP*	79	3.3	0.1	—	7.4	7x2-mm chip
				36	2.3	0.2			10x5-mm chip
4065	748	0.75	*PP*	—	—	—	8	3.8	4-mm bulge/plug formed
4109	756	1.12	*CP*	43	2.9	0.40	—	0.7	14x7-mm chip
4070	758	1.52	CP	35	22.4	63.3	—	64.1	Plug
4105	760	1.12	CP	74	2	NM	—	8.0	11x3-mm chip
4071	762	1.25	CP	47	3	NM	—	11.4	12x7-mm chip
4069	784	1.75	CP	62	21.1	63.8	—	66.4	Plug
4068	812	1.58	CP	LOST	18.1	32.8	—	35.1	Plug
4067	856	0.90	CP	46	16.4	46.8	—	66.7	Penetrator
				137	19.5	38.0			Plug
4066	960	0.90	CP	168	15.3	43.6	—	81.0	Penetrator
				248	18.6	20.7			Plug
4064	1,140	0.25	CP	336	15.4	36.1	—	99.0	Penetrator
				424	29	NM			Plug

Table B-15. Firing Data for 12.7-mm AP M2 Versus Plate No. 316, Type C1, at 0° Obliquity  
(Cross Roll @ 954° C; Anneal @ 788° C, 30 min, AC; 25.53 mm thick; 302-BHN hardness)

Shot No.	V <sub>S</sub> (m/s)	YAW (°)	RES	V <sub>R</sub> (m/s)	L <sub>R</sub> (mm)	M <sub>R</sub> (g)	P <sub>R</sub> (mm)	ΔW (g)	Comments
5458	681	1.50	PP	—	—	—	29.5	5.9	8-mm bulge w/crack
5460	682	1.52	PP	—	—	—	35	5.8	9-mm bulge w/crack
5463	686	1.46	*PP*	—	—	—	PIP	-21.0	7-mm bulge w/crack
5462	689	2.75	*PP*	—	—	—	35	5.3	9-mm bulge w/crack
5464	697	0.56	*PP*	—	—	—	PIP	-4.8	Tip protruding 28mm
5465	699	0.75	*CP*	32	47.1	25.1	—	7.2	Penetrator
5461	706	1.50	*CP*	116 116	47.2 5.2	25.3 2.2	—	7.1	Penetrator Spall
5459	712	2.76	*CP*	96	47.2	25.2	—	7.0	Penetrator
5457	717	4.04	CP	49 50	47.2 3.6	25.3 1.9	—	7.2	Penetrator Spall

Table B-16. Firing Data for 20-mm FSP Versus Plate No. 317, Type C1, at 0° Obliquity  
(Cross Roll @ 954° C; Anneal @ 788° C, 30 min, AC; 25.55 mm thick; 286-BHN hardness)

Shot No.	V <sub>S</sub> (m/s)	YAW (°)	RES	V <sub>R</sub> (m/s)	L <sub>R</sub> (mm)	M <sub>R</sub> (g)	P <sub>R</sub> (mm)	ΔW (g)	Comments
4317	910	0.71	PP	—	—	—	11	14.4	6-mm bulge
4325	944	0.56	PP	—	—	—	13.5	12.9	6-mm bulge w/cracks
4319	961	0.75	*PP*	—	—	—	15	27.4	9-mm bulge w/cracks
4320	970	0.35	*PP*	—	—	—	17	11.2	11-mm bulge w/spall disk 80% formed
4322	980	0.56	*PP*	—	—	—	14.5	14.7	8-mm bulge w/cracks
4323	984	0.50	*CP*	29	15.4	87.0	—	108.7	Spall
4324	985	0.79	*CP*	105	2.7	0.3	—	26.8	11x6-mm spall
4321	987	0.90	*CP*	41	6.8	39.0	—	63.6	Spall
4318	1,002	0.79	CP	63	12.3	70.9	—	100.3	Spall
4316	1,099	1.03	CP	207 237	14.5 16.3	41.0 26.9	—	91.9	Penetrator Plug

Table B-17. Firing Data for 20-mm FSP Versus Plate No. 318, Type C2, at 0° Obliquity  
(Cross Roll @ 954° C; Anneal @ 1,038° C, 30 min, AC; 25.55 mm thick; 302-BHN hardness)

Shot No.	V <sub>S</sub> (m/s)	YAW (°)	RES	V <sub>R</sub> (m/s)	L <sub>R</sub> (mm)	M <sub>R</sub> (g)	P <sub>R</sub> (mm)	ΔW (g)	Comments
4328	685	0.71	PP	—	—	—	5	2.0	2-mm bulge w/cracks
4332	741	1.00	PP	—	—	—	7	3.3	4-mm bulge w/cracks
4330	749	0.90	PP	—	—	—	7	6.1	4-mm bulge w/cracks
4338	754	1.25	*PP*	—	—	—	7	2.7	Plug pushed out 2mm
4337	758	2.14	*CP*	154	2	NM	7	6.0	10x6-mm chip
4333	765	2.46	*PP*	—	—	—	7.5	4.0	4-mm bulge w/cracks
4331	768	1.46	*CP*	129	2	NM	7	5.4	8x4-mm chip
4334	780	0.79	*CP*	132	2.1	0.07	7	5.4	7x5-mm chip
4335	787	0.75	*PP*	—	—	—	10	5.0	Plug pushed out 5mm
4336	793	1.25	CP	132	6.0	0.4	7.5	8.9	12x4-mm spall
4329	797	1.25	CP	49	8.7	5.3	8	11.5	Spall
4327	910	0.50	CP	138 234	15.9 16.5	44.6 20.0	—	69.1	Penetrator Plug
4326	1,050	0.56	CP	251 349	15.8 22.1	43.5 15.0	—	73.9	Penetrator Plug

Table B-18. Firing Data for 12.7-mm AP M2 Versus Plate No. 319, Type C2, at 0° Obliquity  
(Cross Roll @ 954° C; Anneal @ 1,038° C, 30 min, AC; 25.63 mm thick; 302-BHN hardness)

Shot No.	V <sub>S</sub> (m/s)	YAW (°)	RES	V <sub>R</sub> (m/s)	L <sub>R</sub> (mm)	M <sub>R</sub> (g)	P <sub>R</sub> (mm)	ΔW (g)	Comments
5482	635	1.41	PP	—	—	—	28	5.6	5-mm bulge w/cracks
5491	646	1.25	*CP*	128	4.7	2.3	PIP	-13.7	Spall
5488	648	0.75	PP	—	—	—	31	5.6	Spall pushed out 4mm
5483	650	1.27	PP	—	—	—	27	3.3	3-mm bulge w/cracks
5485	650	2.26	*PP*	—	—	—	27	6.3	3-mm bulge w/cracks
5489	653	0.75	*PP*	—	—	—	27.5	1.6	4-mm bulge w/cracks
5484	655	0.00	*PP*	—	—	—	26	1.4	4-mm bulge w/cracks
5487	667	2.02	*CP*	128	8	NM	—	11.7	Spall
5486	673	1.82	*CP*	37	9.2	2.4	—	3.8	Spall
5481	682	0.79	CP	125	6	NM	PIP	-11.3	Spall
5490	688	0.35	CP	144	4.6	1.2	PIP	-12.8	Spall
5480	707	0.79	CP	121 181	47.2 NM	25.2 NM	—	11.3	Penetrator Spall

Table B-19. Firing Data for 12.7-mm AP M2 Versus Plate No. 320, Type C3, at 0° Obliquity  
(Cross Roll @ 954° C; Anneal @ 1,038° C, 30 min., AC, followed by Anneal @788° C, 30 min, AC; 25.53 mm thick; 302-BHN hardness)

Shot No.	V <sub>S</sub> (m/s)	YAW (°)	RES	V <sub>R</sub> (m/s)	L <sub>R</sub> (mm)	M <sub>R</sub> (g)	P <sub>R</sub> (mm)	ΔW (g)	Comments
5497	596	0.56	PP	—	—	—	22	2.7	2-mm bulge w/cracks
5498	613	2.47	PP	—	—	—	22.5	15.1	3-mm bulge w/cracks
5496	613	0.90	PP	—	—	—	24.0	3.5	3-mm bulge w/cracks
5503	618	1.25	PP	—	—	—	25	14.8	3-mm bulge w/cracks
5504	632	0.90	PP	—	—	—	26	5.0	5-mm bulge w/cracks
5499	639	0.79	*PP*	—	—	—	PIP	-7.0	3-mm bulge w/cracks
5495	639	1.03	*CP*	30	1	NM	29	3.9	Chip
5505	643	0.71	*PP*	—	—	—	26	8.2	3-mm bulge w/cracks
5502	653	0.56	*CP*	110	5.1	2.5	PIP	-16.0	Spall
5500	670	3.34	CP	152	4	NM	—	8.2	Spall
5493	682	0.56	CP	58	4.8	1.2	PIP	-19.0	Spall
5492	701	2.70	CP	96	4.8	3.3	PIP	-15.2	Spall

Table B-20. Firing Data for 20-mm FSP Versus Plate No. 321, Type C3, at 0° Obliquity  
(Cross Roll @ 954° C; Anneal @ 1,038° C, 30 min., AC, followed by Anneal @788° C, 30 min, AC; 25.58 mm thick; 302-BHN hardness)

Shot No.	V <sub>S</sub> (m/s)	YAW (°)	RES	V <sub>R</sub> (m/s)	L <sub>R</sub> (mm)	M <sub>R</sub> (g)	P <sub>R</sub> (mm)	ΔW (g)	Comments
4341	694	1.35	PP	—	—	—	5	0.9	3-mm bulge w/cracks
4344	727	0.56	PP	—	—	—	6	3.5	3-mm bulge w/cracks
4348	731	2.06	PP	—	—	—	6.5	3.8	3.5-mm bulge w/cracks
4345	734	1.82	*PP*	—	—	—	7	3.1	Plug pushed out 2mm
4346	734	1.50	*CP*	145	3	NM	8	3.8	11x5-mm chip
4347	740	1.82	*PP*	—	—	—	7.5	2.6	Plug pushed out 2mm
4343	748	2.06	*CP*	37	2	NM	7.5	4.8	6x4-mm chip
4349	760	1.60	CP	94	3.7	0.5	—	5.8	Chip
4342	810	1.35	CP	116	21.0	34.4	—	54.4	Plug
4340	892	0.25	CP	194	21.6	20.7	—	53.6	Plug
4339	1,063	0.35	CP	271 363	13.5 21.4	41.7 31.1	—	83.4	Penetrator Plug

Table B-21. Firing Data for 20-mm FSP Versus Plate No. 322, Type C4, at 0° Obliquity  
(Cross Roll @ 954° C; No Anneal; 25.60 mm thick; 302-BHN hardness)

Shot No.	V <sub>S</sub> (m/s)	YAW (°)	RES	V <sub>R</sub> (m/s)	L <sub>R</sub> (mm)	M <sub>R</sub> (g)	P <sub>R</sub> (mm)	ΔW (g)	Comments
4073	748	1.27	PP	—	—	—	6	2.3	3-mm bulge
4074	855	0.35	PP	—	—	—	9	15.5	4-mm bulge
4075	951	1.25	PP	—	—	—	17.5	15.4	7-mm bulge w/cracks
4115	964	2.50	PP	—	—	—	15	15.4	11-mm bulge w/cracks
4116	968	0.90	PP	—	—	—	16	22.0	9-mm bulge w/spall disk 75% formed
4102	972	1.75	*CP*	42	12.0	88.7	—	103.1	Spall
4117	979	0.35	*PP*	—	—	—	15.5	10.0	9-mm bulge w/spall disk 75% formed
4118	984	1.00	*CP*	34	15.7	86.5	—	118.0	Spall
4077	987	1.27	*PP*	—	—	—	16	14.2	10-mm bulge w/spall disk 50% formed
4119	990	1.12	*CP*	48	16.1	74.6	—	88.7	Spall
4078	991	1.12	*PP*	—	—	—	21	17.2	9-mm bulge w/spall disk 90% formed
4104	996	0.75	CP	87	6.6	46.6	—	54.5	Spall
4076	1,009	1.27	CP	87	15.9	51.0	—	91.9	Spall
4079	1,060	0.79	CP	121 166	14.9 10.6	42.9 66.6	—	129.9	Penetrator Spall
4072	1,159	0.71	CP	305 333	12.7 14.6	36.6 25.2	—	101.8	Penetrator Spall

Table B-22. Firing Data for 12.7-mm AP M2 Versus Plate No. 323, Type C4, at 0° Obliquity  
(Cross Roll @ 954° C; No Anneal; 25.60 mm thick; 302-BHN hardness)

Shot No.	V <sub>S</sub> (m/s)	YAW (°)	RES	V <sub>R</sub> (m/s)	L <sub>R</sub> (mm)	M <sub>R</sub> (g)	P <sub>R</sub> (mm)	ΔW (g)	Comments
5438	631	1.52	PP	—	—	—	27	5.2	5-mm bulge w/cracks
5439	684	2.14	PP	—	—	—	PIP	-20.4	10-mm bulge w/cracks
5440	693	1.25	*PP*	—	—	—	PIP	-2.2	10-mm bulge w/cracks
5443	696	0	*PP*	—	—	—	—	-22.3	Tip protruding 3mm
5441	701	0.71	*CP*	22	1	NM	—	-20.4	Chip
5442	709	3.35	*CP*	48 48	21.6 4.4	6.7 0.9	—	-8.0	Penetrator Spall
5437	722	2.75	CP	118 46	47.3 3.6	25.3 1.4	—	7.6	Penetrator Spall

Table B-23. Firing Data for 20-mm FSP Versus Plate No. 377 at 0° Obliquity  
(Plate No. 303 with Chem-mill; 24.89 mm thick; 302-BHN hardness)

Shot No.	V <sub>s</sub> (m/s)	YAW (°)	RES	V <sub>R</sub> (m/s)	L <sub>R</sub> (mm)	M <sub>R</sub> (g)	P <sub>R</sub> (mm)	ΔW (g)	Comments
6718	772	0.56	*PP*	—	—	—	9	NM	Plug pushed out 4mm
6719	777	0	*PP*	—	—	—	9	NM	Plug pushed out 5mm
6721	780	0.25	*PP*	—	—	—	13	NM	Plug pushed out 3mm
6720	780	0.56	*CP*	36 72	15.2 21.8	47.1 56.7	—	NM	Penetrator Plug
6722	792	0.56	*CP*	115 98	1 2	NM NM	10	NM	5x4-mm chip 10x6-mm chip
6717	798	1.25	*CP*	63 127	15.4 20.9	47.7 65.9	—	NM	Penetrator Plug

Table B-24. Firing Data for 20-mm FSP Versus Plate No. 378 at 0° Obliquity  
(Plate No. 311 with Chem-mill; 24.94 mm thick; 302-BHN hardness)

Shot No.	V <sub>s</sub> (m/s)	YAW (°)	RES	V <sub>R</sub> (m/s)	L <sub>R</sub> (mm)	M <sub>R</sub> (g)	P <sub>R</sub> (mm)	ΔW (g)	Comments
5310	714	1.25	PP	—	—	—	5.5	2.8	3-mm bulge w/cracks
5306	735	0.90	*CP*	83	2	NM	6	3.4	7x9-mm chip
5307	740	0.56	*PP*	—	—	—	6	3.4	3-mm bulge w/cracks
5308	743	1.12	*PP*	—	—	—	6	3.9	3.5-mm bulge w. cracks
5311	746	0.79	*PP*	—	—	—	7	2.0	3-mm bulge w/cracks
5305	747	1.12	*CP*	87	2	NM	7	6.3	10x3-mm chip
5302	748	0.50	*CP*	72	2	NM	7	13.2	10x4-mm chip
5309	753	0.71	*PP*	—	—	—	6	3.7	3-mm bulge w/cracks
5304	771	1.52	*CP*	LOST	2	NM	16	1.1	10x8-mm chip
5312	782	0.50	*CP*	130	1	NM	8.5	4.2	4x2-mm chip
5303	791	0.25	*PP*	—	—	—	12	5.2	Plug pushed out 7mm

Table B-25. Firing Data for 20-mm FSP Versus Plate No. 379 at 0° Obliquity  
(Plate No. 315 with Chem-mill; 24.77 mm thick; 302-BHN hardness)

Shot No.	V <sub>S</sub> (m/s)	YAW (°)	RES	V <sub>R</sub> (m/s)	L <sub>R</sub> (mm)	M <sub>R</sub> (g)	P <sub>R</sub> (mm)	ΔW (g)	Comments
5326	709	1.00	PP	—	—	—	6	2.8	3-mm bulge w/cracks
5324	709	0.56	*CP*	67	2	NM	5.5	2.4	5x4-mm chip
5327	710	0.71	PP	—	—	—	7	2.7	Plug pushed out 2mm
5325	713	0.56	*PP*	—	—	—	5	2.3	2-mm bulge w/cracks
5322	723	0.71	*PP*	—	—	—	7.5	5.0	Plug pushed out 4mm
5329	742	0.9	*PP*	—	—	—	6.5	2.7	3.5-mm bulge w/cracks
5323	746	0.56	*CP*	132	3	NM	10	6.0	12x12-mm chip
5321	748	0.25	*CP*	46	16.7	46.2	—	56.9	Penetrator Plug
				46	21.5	51.7			
5328	754	0.35	*PP*	—	—	—	11	3.3	Plug pushed out 5mm
5330	756	0.25	*PP*	—	—	—	10	4.1	Plug pushed out 5mm
5331	763	1.80	*CP*	141	2.3	0.5	9	5.8	10x9-mm chip
5332	770	0	*CP*	124	1	NM	9	3.4	5x2-mm chip

Table B-26. Firing Data for 20-mm FSP Versus Plate No. 380 at 0° Obliquity  
(Plate No. 322 with Chem-mill; 25.25 mm thick; 302-BHN hardness)

Shot No.	V <sub>S</sub> (m/s)	YAW (°)	RES	V <sub>R</sub> (m/s)	L <sub>R</sub> (mm)	M <sub>R</sub> (g)	P <sub>R</sub> (mm)	ΔW (g)	Comments
5314	972	1.03	PP	—	—	—	17	17.8	Spall pushed out 10mm
5316	985	0.25	*PP*	—	—	—	16	23.0	Spall pushed out 4mm
5317	987	1.06	*PP*	—	—	—	16	66.9	10-mm bulge w/cracks
5320	988	0.25	*PP*	—	—	—	17	18.4	8-mm bulge w/cracks
5318	992	0.56	*CP*	66	10	NM	—	68.5	Spall
5319	1,005	0	*CP*	90	16.4	62.9	—	86.3	Spall
5315	1,012	0.50	*CP*	97	14.9	62.1	—	48.6	Spall
5313	1,013	1.52	CP	93	15.7	41.6	—	108.7	Penetrator Spall
				134	15.2	71.7			

INTENTIONALLY LEFT BLANK.

NO. OF  
COPIES    ORGANIZATION

1    ADMINISTRATOR  
DEFENSE TECHNICAL INFO CTR  
ATTN DTIC OCA  
8725 JOHN J KINGMAN RD  
STE 0944  
FT BELVOIR VA 22060-6218

1    DIRECTOR  
US ARMY RSCH LABORATORY  
ATTN AMSRL CI AI R REC MGMT  
2800 POWDER MILL RD  
ADELPHI MD 20783-1197

1    DIRECTOR  
US ARMY RSCH LABORATORY  
ATTN AMSRL CI LL TECH LIB  
2800 POWDER MILL RD  
ADELPHI MD 207830-1197

1    DIRECTOR  
US ARMY RSCH LABORATORY  
ATTN AMSRL D D SMITH  
2800 POWDER MILL RD  
ADELPHI MD 20783-1197

8    CDR US ARMY TACOM  
ATTN AMSTA TR S T FURMANIAK  
      S GOODMAN D HANSEN  
      L PROKURAT FRANKS  
      D THOMAS J THOMPSON  
      AMSTA TR E MATL  
      B ROOPCHAND  
      AMSTA TR STI J CARIE  
WARREN MI 48397-5000

2    PROJECT MANAGER  
GROUND SYSTEM INTEGRATION  
ATTN SFAE GCSS W GSI  
      T DEAN J ROWE  
WARREN MI 48397-5000

3    CDR US ARMY RESEARCH OFFICE  
ATTN J BAILEY K IYER  
      K LOGAN  
PO BOX 12211  
RESEARCH TRIANGLE PARK NC  
                                  27709-2211

2    CDR NGIC  
ATTN J CRIDER W GSTATTENBAUER  
220 SEVENTH AVE  
CHARLOTTESVILLE VA 22901-5391

NO. OF  
COPIES    ORGANIZATION

1    CIA  
ATTN OSWR DSD W WALTMAN  
ROOM 5P0110 NHB  
WASHINGTON DC 20505

1    DIR ARPA  
3701 NORTH FAIRFAX DR  
ARLINGTON VA 22203-1714

1    PM BFVS  
ATTN SFAE GCSS W BV S DAVIS  
WARREN MI 48397-5000

1    CDR CARDEROCK DIV NSWC  
CODE 28 (R PETERSON)  
9500 MACARTHUR BLVD  
W BETHESDA MD 20817-5700

1    DEPT OF THE NAVY  
OFC DIR REPORTING PROG MGR  
ADVANCED AMPHIBIOUS ASSAULT  
ATTN DEREK ERDLEY  
WASHINGTON DC 20380-0001

3    LAWRENCE LIVERMORE NATL LAB  
ATTN R GOGOLEWSKI MS L290  
      R LANDINGHAM L369  
      J REAUGH L32  
PO BOX 808  
LIVERMORE CA 94550

2    LOS ALAMOS NATL LABORATORY  
ATTN F ADDESSIO M BURKETT  
LOS ALAMOS NM 87545

5    SANDIA NATL LAB  
ATTN J ASAY MS 0548  
      R BRANNON MS 0820  
      L CHHABILDAS MS 0821  
      D CRAWFORD ORG 0821  
      M FORRESTAL DIV 1551  
PO BOX 5800  
ALBUQUERQUE NM 87185-0307

1    NAVAL RSCH LABORATORY  
CODE 6684  
4555 OVERLOOK AVE SW  
WASHINGTON DC 20375

1    AIR FORCE ARMAMENT LAB  
ATTN AFATL DLJW W COOK  
EGLIN AFB FL 32542

<u>NO. OF COPIES</u>	<u>ORGANIZATION</u>
5	INST FOR ADVNCD TECH ATTN S BLESS H FAIR T KIEHNE D LITTLEFIELD R SUBRAMANIAN PO BOX 202797 AUSTIN TX 78720-2797
2	UNIV OF DAYTON RSCH INST KLA14 ATTN N BRAR A PIEKUTOWSKI 300 COLLEGE PARK DAYTON OH 45469-0182
3	SOUTHWEST RSCH INST ATTN C ANDERSON J RIEGEL J WALKER 6220 CULEBRA RD SAN ANTONIO TX 78238
4	US DEPT OF ENERGY ALBANY RSCH CENTER ATTN J HANSEN (2 CYS) P TURNER (2 CYS) 1450 QUEEN AVENUE SW ALBANY OR 97321-2198
1	BROWN UNIV DIV OF ENGINEERING ATTN R CLIFTON PROVIDENCE RI 02912
2	UNIV OF CA SAN DIEGO DEPT OF APPL MECH & ENGR SVCS R011 ATTN S NEMAT NASSER M MEYERS LA JOLLA CA 92093-0411
1	ARMORWORKS ATTN W PERCIBALLI 910 E MOUNTAIN SKY AVE PHOENIX AZ 85048
2	AERONAUTICAL RSCH ASSOC ATTN R CONTILIANO J WALKER PO BOX 2229 50 WASHINGTON RD PRINCETON NJ 08540
2	ALLIANT TECHSYSTEMS INC ATTN T HOLMQUIST G JOHNSON 600 SECOND STREET NE HOPKINS MN 55343

<u>NO. OF COPIES</u>	<u>ORGANIZATION</u>
1	ALME AND ASSOC ATTN M ALME PO BOX 1388 LOS ALAMOS NM 87544-1388
1	APPLIED RSRCH ASSOCIATES INC ATTN J YATTEAU 5941 S MIDDLEFIELD RD STE 100 LITTLETON CO 80123
1	APPLIED RSCH ASSOC INC ATTN D GRADY 4300 SAN MATEO BLVD NE STE A 220 ALBUQUERQUE NM 87110
1	BRIGGS COMPANY ATTN J BACKOFEN 2668 PETERSBOROUGH ST HERNDON VA 222071-2443
1	CENTURY DYNAMICS INC ATTN N BIRNBAUM 2333 SAN RAMON VALLEY BLVD SAN RAMON CA 94583-1613
3	CERCOM INC ATTN R PALICKA G NELSON B CHEN 1960 WATSON WAY VISTA CA 92083
1	CYPRESS INTERNATIONAL ATTN A CAPONECCHI 1201 E ABINGDON DR ALEXANDRIA VA 22314
1	R J EICHELBERGER 409 W CATHERINE ST BEL AIR MD 21014 3613
1	EPSTEIN AND ASSOC ATTN K EPSTEIN 2716 WEMBERLY DRIVE BELMONT CA 94002
2	GALT ALLOYS INC ATTN S FELLOWS S GIANGIORDANO 122 CENTRAL PLAZA N CANTON OH 44702

NO. OF  
COPIES    ORGANIZATION

NO. OF  
COPIES    ORGANIZATION

- 6    GDLS  
      ATTN W BURKE MZ436 21 24  
          G CAMPBELL MZ436 30 44  
          D DEBUSSCHER MZ436 20 29  
          J ERIDON MZ436 21 24  
          W HERMAN MZ435 01 24  
          S PENTESCU MZ436 21 24  
      38500 MOUND RD  
      STERLING HTS MI 48310-3200
- 1    GENERAL RSCH CORP  
      PO BOX 6770  
      SANTA BARBARA CA 93160-6770
- 1    INTERNATL RSCH ASSOC  
      ATTN D ORPHAL  
      4450 BLACK AVE  
      PLEASANTON CA 94566
- 1    JET PROPULSION LABORATORY  
      IMPACT PHYSICS GROUP  
      ATTN M ADAMS  
      4800 OAK GROVE DRIVE  
      PASADENA CA 91109-8099
- 1    KAMAN SCIENCES CORP  
      1500 GARDEN OF THE GODS RD  
      COLORADO SPRINGS CO 80907
- 3    O'GARA HESS AND EISENHARDT  
      ATTN G ALLEN  
          D MALONE    T RUSSELL  
      9113 LE SAINT DR.  
      FAIRFIELD OH 45014
- 1    OREMET WAH CHANG  
      ATTN Y KOSAKA  
      PO BOX 580  
      ALBANY OR 97321
- 4    POULTER LABORATORY  
      SRI INTERNATIONAL  
      ATTN D CURRAN    R KLOOP  
          L SEAMAN    D SHOCKEY  
      333 RAVENSWOOD AVE  
      MENLO PARK CA 94025
- 1    RMI TITANIUM COMPANY  
      ATTN W LOVE  
      2950 BIRCH ST  
      BREA CA 92621

- 6    RMI TITANIUM COMPANY  
      ATTN J BENNETT    E CHRIST  
          F JANOWSKI    W PALLANTE  
          S ROBERTSON    O YU  
      1000 WARREN AVENUE  
      NILES OH 44446
- 2    TIMET  
      ATTN P BANIA    J FANNING  
      PO BOX 2128  
      HENDERSON NV 89009
- 2    TIMET  
      ATTN J BARBER  
      1999 BROADWAY STE 4300  
      DENVER CO 80202
- 1    SAIC  
      ATTN J FURLONG MS 264  
      1710 GOODRIDGE DR  
      MCLEAN VA 22102
- 1    BOB SKAGGS  
      RT 11 BOX 81E  
      SANTA FE NM 87501
- 2    SIMULA INC  
      ATTN R WOLFFE  
      10016 SOUTH 51ST STREET  
      PHOENIX AZ 85044
- 8    UNITED DEFENSE LP  
      ATTN J DORSCH    V HORVATICH  
          B KARIYA    M MIDDIONE  
          J MORROW    R MUSANTE  
          R RAJAGOPAL    D SCHADE  
      PO BOX 367  
      SANTA CLARA CA 95103
- 3    UNITED DEFENSE LP  
      ATTN E BRADY  
          R JENKINS    J JOHNSON  
      PO BOX 15512  
      YORK PA 17405-1512
- 1    ZERNOW TECH SVCS INC  
      ATTN L ZERNOW  
      425 W BONITA AVE  
      SUITE 208  
      SAN DIMAS CA 91773

<u>NO. OF COPIES</u>	<u>ORGANIZATION</u>
1	EMBASSY OF AUSTRALIA COUNSELLOR DEFENCE SCIENCE 1601 MASSACHUSETTS AVE NW WASHINGTON DC 20036-2273
	<u>ABERDEEN PROVING GROUND</u>
2	DIRECTOR US ARMY RSCH LABORATORY ATTN AMSRL CI LP (TECH LIB) BLDG 305 APG AA
1	DIR USA EBCC ATTN SCBRD RT 5183 BLACKHAWK RD APG-EA MD 21010-5424
1	CDR USA SBCCOM ATTN AMSCB CII 5183 BLACKHAWK RD APG-EA MD 21010-5424
2	DIR USAMSA ATTN AMXSY D AMXSY MP H COHEN BLDG 392
1	CDR USATEC ATTN AMSTE TC RYAN BLDG
3	CDR USAATC ATTN STEAC LI LV E SANDERSON M SIMON (2 CYS) BLDG 400
1	DIRECTOR US ARMY RSCH LABORATORY ATTN AMSRL SL I BLDG 328
1	DIRECTOR US ARMY RSCH LABORATORY ATTN AMSRL WM M D VIECHNICKI BLDG 4600
1	DIRECTOR US ARMY RSCH LABORATORY ATTN AMSRL WM ME J BEATTY BLDG 4600

<u>NO. OF COPIES</u>	<u>ORGANIZATION</u>
1	DIRECTOR US ARMY RSCH LABORATORY ATTN AMSRL WM T B BURNS BLDG 4600
29	DIRECTOR US ARMY RSCH LABORATORY ATTN AMSRL WM TA W BRUCHEY M BURKINS (15 CYS) G FILBY W GILlich W GOOCH (2 CYS) T HAVEL D HACKBARTH E HORWATH Y HUANG D KLEPONIS H MEYER M NORMANDIA J RUNYEON M ZOLTOSKI BLDG 393
7	DIRECTOR US ARMY RSCH LABORATORY ATTN AMSRL WM TC K KIMSEY M LAMPSON L MAGNESS D SCHEFFLER G SILSBY R SUMMERS W WALTERS BLDG 309
14	DIRECTOR US ARMY RSCH LABORATORY ATTN AMSRL WM TD A DIETRICH T FARRAND D DANDEKAR K FRANK A GUPTA M RAFTENBERG R RAJENDRAN E RAPACKI N RUPERT M SCHEIDLER S SCHOENFELD S SEGLETES T WEERASOORIYA T WRIGHT BLDG 309
12	DIR USARL ATTN AMSRL WM TE A NIILER BLDG 120
	<u>ABSTRACT ONLY</u>
1	DIRECTOR US ARMY RSCH LABORATORY ATTN AMSRL CI AP TECH PUB BR 2800 POWDER MILL RD ADELPHI MD 20783-1197

<u>NO. OF</u> <u>COPIES</u>	<u>ORGANIZATION</u>	<u>NO. OF</u> <u>COPIES</u>	<u>ORGANIZATION</u>
3	AERONAUTICAL & MARITIME RSCH LABORATORY ATTN N BURMAN S CIMPOERU D PAUL PO BOX 4331 MELBOURNE VIC 3001 AUSTRALIA	1	CONDAT ATTN J KIERMEIR MAXILLANSTR 28 8069 SCHEYERN FERNHAG GERMANY
1	ARMSCOR ATTN L DU PLESSIS PRIVATE BAG X337 PRETORIA 0001 SOUTH AFRICA	2	DEFENCE PROCUREMENT AGCY ATTN G LAUBE W ODERMATT BALLISTICS WPNS & COMBAT VEHICLE TEST CTR CH 3602 THUN SWITZERLAND
1	BATTELLE INGENIEURTECHNIK GMBH ATTN W FUCKE DUESSELDORFFER STR 9 D 65760 ESCHBORN GERMANY	1	TDW ATTN M HELD POSTFACH 1340 D 86523 SCHROBENHAUSEN GERMANY
1	DEFENCE RSCH AGENCY FORT HALSTEAD SEVEN OAKS KENT TN14 7BP UNITED KINGDOM	6	DEFENCE RSCH AGENCY ATTN W CARSON I CROUCH C FREW T HAWKINS B JAMES B SHRUBSALL CHOBHAM LANE CHERTEY SURREY KT16 OEE UNITED KINGDOM
1	CARLOS III UNIV OF MADRID ATTN C NAVARRO ESCUELA POLITÉENICA SUPERIOR C/. BUTARQUE 15 28911 LEGANÉS MADRID SPAIN	1	DEFENCE RSCH ESTAB SUFFIELD ATTN C WEICKERT BOX 4000 MEDICINE HAT ALBERTA T1A 8K6 CANADA
1	CELSIUS MATERIALTEKNIK KARLSKOGA AB ATTN L HELLNER S 691 80 KARLSKOGA SWEDEN	1	DEFENCE RSH ESTAB VALCARTIER ARMAMENTS DIVISION ATTN R DELAGRAVE 2459 PIE X1 BLVD N PO BOX 8800 CORCELETTE QUEBEC GOA 1R0 CANADA
3	CENTRE D'ETUDES GRAMAT ATTN J CAGNOUX C GALLIC J TRANCHET GRAMAT 46500 FRANCE	3	DEUTSCH FRANZÖSISCHES FORSCHUNGSINSTITUT ST LOUIS ATTN H ERNST K HOOG H LERR CÉDEX 5 RUE DU GÉNÉRAL CASSAGNOU F 68301 SAINT LOUIS FRANCE
1	MINISTRY OF DEFENCE DGA/DSP/STTC ATTN G BRAULT 4 RUE DE LA PORTE D'ISSY 00460 ARMÉES F 75015 PARIS FRANCE	1	DIEHL GMBH AND CO ATTN M SCHILDKNECHT FISCHBACHSTRASSE 16 D 90552 RÖT BENBACH AD PEGNITZ GERMANY

<u>NO. OF COPIES</u>	<u>ORGANIZATION</u>	<u>NO. OF COPIES</u>	<u>ORGANIZATION</u>
1	DYNAMEC RSCH AB ATTN Å PERSSON PO BOX 201 S 151 23 SÖDERTÄLJE SWEDEN	1	INST OF CHEMICAL PHYSICS ATTN S RAZORENOV 142432 CHERNOGOLOVKA MOSCOW REGION RUSSIAN REPUBLIC
3	ETBS DSTI ATTN P BARNIER M SALLES B GAILLY ROUTE DE GUERAY BOITE POSTALE 712 18015 BOURGES CEDEX FRANCE	7	INST FOR PROBLEMS IN MATERIALS SCIENCE ATTN S FIRSTOV B GALANOV O GRIGORIEV V KARTUZOV V KOVTUN Y MILMAN V TREFILOV 3 KRHYZHANOVSKY STR 252142 KIEV 142 UKRAINE
2	FEDERAL MINISTRY OF DEFENCE DIR OF EQPT & TECH LAND RÜV 2 ATTN D HAUG L REPPER POSTFACH 1328 53003 BONN GERMANY	1	INST FOR PROBLEMS OF STRESS ATTN G STEPANOV TIMIRYAZEVSAYA STR 2 252014 KIEV UKRAINE
4	FRANHOFER INSTITUT FÜR KURZZEITDYNAMIK ERNST MACH INSTITUT ATTN V HOHLER E STRASSBURGER R THAM K THOMA ECKERSTRASSE 4 D 79 104 FREIBURG GERMANY	3	INST OF MECH ENGINEERING PROBLEMS ATTN V BULATOV D INDEITSEV Y MESCHERYAKOV BOLSHOY 61 VO ST PETERSBURG 199178 RUSSIAN REPUBLIC
1	MINISTRY OF DEFENCE DGA/SPART ATTN C CANNAVO 10 PLACE GEORGES CLEMENCEAU BP19 F 92211 SAINT CLOUD CÉDEX FRANCE	2	IOFFE PHYSICO TECH INST ATTN E DROBYSHEVSKI A KOZHUSHKO ST PETERSBURG 194021 RUSSIAN REPUBLIC
2	HIGH ENERGY DENSITY RSCH CTR ATTN V FORTOV G KANEL IZHORSKAYA STR 13/19 MOSCOW 127412 RUSSIAN REPUBLIC	1	K&W THUN ATTN W LANZ ALLMENDSSTRASSE 86 CH 3602 THUN SWITZERLAND
1	INGENIEURBÜRO DEISENROTH ATTN F DEISENROTH AUF DE HARDT 33 35 D 5204 LOHMAR 1 GERMANY	1	R OGORKIEWICZ 18 TEMPLE SHEEN LONDON SW 14 7RP UNITED KINGDOM
		1	MAX PLANCK INSTITUT FUR EISENFORSCHUNG GMBH ATTN C DERDER MAX PLANCK STRASSE 1 40237 DUSSELDORF GERMANY

<u>NO. OF COPIES</u>	<u>ORGANIZATION</u>	<u>NO. OF COPIES</u>	<u>ORGANIZATION</u>
2	NATL DEFENCE HEADQUARTERS ATTN PMO MRCV MAJ M PACEY PMO LAV A HODAK OTTOWA ONTARIO KIA OK2 CANADA	3	SWEDISH DEFENCE RSCH ESTAB ATTN L HOLMBERG B JANZON I MELLGARD BOX 551 S 147 25 TUMBA SWEDEN
1	OTO BREDA ATTN M GUALCO VIA VALDIOCCHI 15 I 19136 LA SPEZIA ITALY	1	TECHNION INST OF TECH FACULTY OF MECH ENGINEERING ATTN S BODNER TECHNION CITY HAIFA 32000 ISRAEL
5	RAPHAEL BALLISTICS CENTER ATTN M MAYSELESS Y PARTOM G ROSENBERG Z ROSENBERG Y YESHURUN BOX 2250 HAIFA 31021 ISRAEL	3	TECHNISCHE UNIVERSITÄT CHEMNITZ ZWICKAU ATTN A SCHROEDTER L KRUEGER L MEYER POSTFACH D 09107 CHEMNITZ GERMANY
1	RSCH INST OF MECHANICS NIZHNIY NOVGOROD STATE UNIV ATTN A SADYRIN PR GAYARINA 23 KORP6 NIZHNIY NOVGOROD 603600 RUSSIAN REPUBLIC	2	TNO PRINS MAURITS LAB ATTN. H PESKES R IJSSELSTEIN LANGE KLEIWEG 137 PO BOX 45 2280 AA RIJSWIJK THE NETHERLANDS
1	ROYAL MILITARY ACADEMY ATTN E CELENS RENAISSANCE AVE 30 B 1040 BRUSSELS BELGIUM	6	CENTRE DE RECHERCHES ET D'ETUDES D'ARCUEIL ATTN D BOUVART C COTTENNOT S JONNEAUX H ORSINI S SERROR F TARDIVAL 16 BIS AVENUE PRIEUR DE LA CÔTE D'OR F 94114 ARCUEIL CÉDEX FRANCE
1	ROYAL NETHERLANDS ARMY ATTN J HOENEVELD V D BURCHLAAN 31 PO BOX 90822 2509 LS THE HAGUE NETHERLANDS	2	CDR EUROPEAN RSCH OFFICE USARDSG (UK) ATTN S SAMPATH J ILLINGER PSC 802 BOX 15 FPO AE 09499-1500
1	DEFENCE MATERIEL ADMINISTRN WEAPONS DIRECTORATE ATTN A BERG S 11588 STOCKHOLM SWEDEN		
2	SWEDISH DEFENCE RSCH ESTAB DIVISION OF MATERIALS ATTN S J SAVAGE J ERIKSON S 172 90 STOCKHOLM SWEDEN		

INTENTIONALLY LEFT BLANK.

# REPORT DOCUMENTATION PAGE

Form Approved  
OMB No. 0704-0188

Public reporting burden for this collection of information is estimated to average 1 hour per response, including the time for reviewing instructions, searching existing data sources, gathering and maintaining the data needed, and completing and reviewing the collection of information. Send comments regarding this burden estimate or any other aspect of this collection of information, including suggestions for reducing this burden, to Washington Headquarters Services, Directorate for Information Operations and Reports, 1215 Jefferson Davis Highway, Suite 1204, Arlington, VA 22202-4302, and to the Office of Management and Budget, Paperwork Reduction Project (0704-0188), Washington, DC 20503.

1. AGENCY USE ONLY (Leave blank)		2. REPORT DATE July 2000	3. REPORT TYPE AND DATES COVERED Final	
4. TITLE AND SUBTITLE The Effect of Thermo-mechanical Processing on the Ballistic Limit Velocity of Extra Low Interstitial Titanium Alloy Ti-6AL-4V			5. FUNDING NUMBERS PR: 622601DC05	
6. AUTHOR(S) Burkins, M.S. (ARL); Hansen, J.S.; Paige, J.I.; Turner, P. C.(DOE)				
7. PERFORMING ORGANIZATION NAME(S) AND ADDRESS(ES) U.S. Army Research Laboratory Weapons & Materials Research Directorate Aberdeen Proving Ground, MD 21005-5066			8. PERFORMING ORGANIZATION REPORT NUMBER	
9. SPONSORING/MONITORING AGENCY NAME(S) AND ADDRESS(ES) U.S. Army Research Laboratory Weapons & Materials Research Directorate Aberdeen Proving Ground, MD 21005-5066			10. SPONSORING/MONITORING AGENCY REPORT NUMBER ARL-MR-486	
11. SUPPLEMENTARY NOTES				
12a. DISTRIBUTION/AVAILABILITY STATEMENT Approved for public release; distribution is unlimited.			12b. DISTRIBUTION CODE	
13. ABSTRACT (Maximum 200 words) <p>Although titanium alloys have been widely used for aerospace applications, they have seldom been used in armor systems. In an effort to provide increased information to armored vehicle designers, the U.S. Army Research Laboratory (ARL) and the U.S. Department of Energy's Albany Research Center (ARC) performed a joint research program to evaluate the effect of thermo-mechanical processing on the ballistic limit velocity for an extra-low interstitial grade of the titanium alloy Ti-6Al-4V. ARC obtained MIL-T-9046J, AB-2 plates from RMI Titanium Company, rolled these plates to final thickness, performed the annealing, and collected mechanical and micro-structural information. ARL then evaluated the plates with 20-mm fragment-simulating projectiles and 12.7-mm armor-piercing M2 bullets in order to determine the ballistic limit velocity of each plate. Titanium processing and annealing did have an effect on the ballistic limit velocity, but the magnitude of the effect depended on which penetrator was used.</p>				
14. SUBJECT TERMS annealing    ELI    FSP    rolling    12.7 mm AP 20 mm    fragments    limit velocity    titanium			15. NUMBER OF PAGES 65	
			16. PRICE CODE	
17. SECURITY CLASSIFICATION OF REPORT Unclassified	18. SECURITY CLASSIFICATION OF THIS PAGE Unclassified	19. SECURITY CLASSIFICATION OF ABSTRACT Unclassified	20. LIMITATION OF ABSTRACT	