

19 APR 2000

**Development of Numerical Constitutive Models for Carbon-Carbon Composites**  
**F49620-94-1-0259,P00002**  
**John Whitcomb**

Center for Mechanics of Composites  
Texas A & M University  
**Final Report**  
May 15, 1994 - August 31, 1998

### **Objective**

Predict the stiffness and strength of oxidation-resistant carbon-carbon subjected to thermal and mechanical loads in an oxidizing environment

### **Status of effort**

A three-dimensional progressive failure analysis of carbon-carbon composites was developed. To facilitate the study, various mesh generators and graphical pre- and post-processing tools were developed. These tools were used to study carbon-carbon during cool-down from processing temperature and subsequent mechanical loads. This grant was tightly integrated with the AASERT grant F49620-93-1-0471, which ended last year. The student supported under the AASERT grant, Clint Chapman, has graduated (and is employed) with a Ph.D. This final year of the subject grant has been invested in documenting our efforts in the open literature and assembling documentation for the tools developed by Dr. Chapman so they could be used in subsequent projects.

### **Accomplishments**

Two of the biggest challenges in the analysis of textile composites is developing a valid 3D finite element mesh and deriving boundary conditions for the smallest possible analysis region (since the computational challenge is inherently high). We can now obtain meshes and boundary conditions for plain and 8 harness satin weaves with a wide range of waviness, tow cross-section, and mesh refinement. Only a few parameters have to be specified...the rest is automatic. We have also enhanced our visualization programs and associated utilities so that it is much more convenient to examine stress and strain distributions, deformed geometries, damage distribution, and differences between models.

We have continued to document our efforts in the literature. The results of our simulations were presented at ICCE/5 in July, 1998. A journal paper describing the simulations is almost complete. The title is "Thermally Induced Damage Initiation and Growth in Carbon-Carbon Composites." Another paper, "Derivation of Boundary Conditions for Micromechanics Analyses of Plain and Satin Weave Composites," has already been submitted to the Journal of Composite Materials. The new techniques developed in this paper greatly simplify the challenge of deriving boundary conditions. Reports from previous years of this grant include copies of

**REPORT DOCUMENTATION PAGE**

AFRL-SR-BL-TR-00-

Public reporting burden for this collection of information is estimated to average 1 hour per response, including the time for reviewing instructions, searching existing data sources, gathering the data, reviewing the collection of information, and completing and reviewing the collection of information. Send comments regarding this burden estimate or any other aspect of this collection of information, including suggestions for reducing the burden, to Washington Headquarters Services, Directorate for Information Operations and Reports, 1215 Jefferson Davis Highway, Suite 1204, Arlington, VA 22202-4302, and to the Office of Management and Budget, Paperwork Project, Washington, DC 20503.

ewing  
nation

0290

<b>1. AGENCY USE ONLY (Leave blank)</b>	<b>2. REPORT DATE</b>	<b>3. REPORT TYPE AND DATES COVERED</b> Final Technical Report 14 May 94 - 31 Aug 98
<b>4. TITLE AND SUBTITLE</b> (U) DEVELOPMENT OF NUMERICAL CONSTITUTIVE MODELS FOR CARBON-CARBON COMPOSITES		<b>5. FUNDING NUMBERS</b> F49620-94-1-0259  2302/BS 61102F
<b>6. AUTHOR(S)</b> JOHN WHITCOMB		
<b>7. PERFORMING ORGANIZATION NAME(S) AND ADDRESS(ES)</b> TEXAS A&M UNIVERSITY CENTER FOR MECHANICS OF COMPOSITES COLLEGE STATION, TX 77843		<b>8. PERFORMING ORGANIZATION REPORT NUMBER</b>
<b>9. SPONSORING/MONITORING AGENCY NAME(S) AND ADDRESS(ES)</b> AIR FORCE OFFICE OF SCIENTIFIC RESEARCH AEROSPACE AND MATERIALS SCIENCES DIRECTORATE 801 N. RANDOLPH STREET, ROOM 732 ARLINGTON, VA 22203-1977		<b>10. SPONSORING/MONITORING AGENCY REPORT NUMBER</b>
<b>11. SUPPLEMENTARY NOTES</b>		
<b>12a. DISTRIBUTION AVAILABILITY STATEMENT</b> APPROVED FOR PUBLIC RELEASE DISTRIBUTION IS UNLIMITED		<b>12b. DISTRIBUTION CODE</b>
<b>13. ABSTRACT (Maximum 200 words)</b> A three-dimensional progressive failure analysis of carbon-carbon composites was developed. To facilitate the study, various mesh generators and graphical pre- and post-processing tools were developed. These tools were used to study carbon-carbon during cool-down from processing temperature and subsequent mechanical loads. This grant was tightly integrated with the AASERT grant F49620-93-1-0471, which ended last year. The student supported under the AASERT grant, Clint Chapman, has graduated (and is employed) with a Ph.D. This final year of the subject grant has been invested in documenting our efforts in the open literature and assembling documentation for the tools developed by Dr. Champan so they could be used in subsequent projects.		
<b>14. SUBJECT TERMS</b>		<b>15. NUMBER OF PAGES</b> 28
		<b>16. PRICE CODE</b>
<b>17. SECURITY CLASSIFICATION OF REPORT</b> UNCLASSIFIED	<b>18. SECURITY CLASSIFICATION OF THIS PAGE</b> UNCLASSIFIED	<b>19. SECURITY CLASSIFICATION OF ABSTRACT</b> UNCLASSIFIED
<b>20. LIMITATION OF ABSTRACT</b>		

papers and Clint's PhD dissertation, so they will not be included herein. Attached is a copy of the paper "Derivation of Boundary Conditions for Micromechanics Analyses of Plain and Satin Weave Composites," which has been submitted. When other papers are ready for submission to a journal, they will be forwarded to the technical monitor.

#### **Peer Reviewed Publications**

1. Whitcomb, J.D.; Chapman, C.: Effect of Assumed Tow Architecture and Mesh Refinement on the Predicted Moduli and Stresses in Plain Weave Composites. *Journal of Composite Materials*. Vol. 29, No. 16, pp. 2134-2159, 1995.
2. Whitcomb, J.D.; Srengan, K.; Chapman, C.: Evaluation of Homogenization for Global/Local Stress Analysis of Textile Composites. *Composite Structures*. Vol. 31, No. 2, pp. 137-149, 1995.
3. Whitcomb, J.D.; Chapman, C.: Analysis of Plain Weave Composites Subjected to Flexure. *Mechanics of Composite Materials and Structures*. Vol. 5, No. 1, pp. 41-53, 1998.
4. Srengan, K.; Whitcomb, J.D.; Chapman, C.: Modal Technique for Three-Dimensional Stress Analysis of Plain Weave Composites. *Composite Structures*. Vol. 39, NO. 1-2, pp. 145-156, 1997.
5. Whitcomb, J.D.; Chapman, C.D., Tang, X.: Derivation of Boundary Conditions for Micromechanics Analyses of Plain and Satin Weave Composites. Submitted 8/98 to *Journal of Composite Materials*.
6. Chapman, C.D.; Whitcomb, J.D.: Thermally Induced Damage Initiation and Growth in Carbon-Carbon Composites (manuscript in preparation).

#### **Conference and Workshop Presentations**

1. Whitcomb, J.D.; Srengan, K.; and Chapman, C.: Evaluation of Homogenization for Global/Local Stress Analysis of Textile Composites. Presented at the AIAA/ASME/ASCE/AHS/ASC 35th Structures, Structural Dynamics, and Materials conference, Hilton Head, South Carolina, April 18-20, 1994.
2. Whitcomb, J.D.; Srengan, K.; and Chapman, C.: Simulation of Progressive Failure in Plain Weave Textile Composites. Presented at 1994 ASME Winter Annual Meeting, Chicago, Illinois, November 13-18, 1994.
3. Chapman, C.; Whitcomb, J.D.; and Srengan, K.: Analysis of Woven Composites Subjected to Flexure. Society of Engineering Science 31<sup>st</sup> Annual Technical Meeting, College Station, Texas, October 10-12, 1994.

4. Srirengan, K.; Whitcomb, J.D.; and Chapman, C.: Three-Dimensional Analysis of Woven Composites Subjected to Flexure. Third U.S. National Congress of Computational Mechanics, June 12-14, 1995.
5. Chapman, C.; and Whitcomb, J.D.: Thermomechanical Characterization of Plain and Satin Weave Carbon-Carbon Composites. Third U.S. National Congress of Computational Mechanics, June 12-14, 1995.
6. Whitcomb, J.D.; Srirengan, K.; and Chapman, C.: Modal Technique for Three Dimensional Stress Analysis of Plain Weave Composites. ICCM-10, Whistler, Canada, August 14-29, 1995.
7. Chapman, C.; and Whitcomb, J.D.: Strategy for Modeling Eight-Harness Satin Weave Carbon/Carbon Composites Subjected to Thermal Loads. Presented at 37th AIAA/ASME/ASCE/AHS/ASC Structures, Structural Dynamics, and Materials Conference, Salt Lake City, UT, April 15-17, 1996.
8. Whitcomb, J.D.; and Chapman, C.: Thermally Induced Damage Initiation and Growth in Carbon-Carbon Composites. Presented at the 38<sup>th</sup> AIAA/ASME/ASCE/AHS/ASC Structures, Structural Dynamics, and Materials Conference, Kissimmee, FL, April 7-10, 1997.
9. Whitcomb, J.D.; and Chapman, C.: Damage Initiation and Growth in Carbon-Carbon Composites Subjected to Thermal and Mechanical Loads. Presented at the 1997 Joint ASME/ASEE/SES Summer Meeting, Chicago, IL, June 28- July 2, 1997.
10. Whitcomb, J.D.; Tang, X.; and Chapman, C.: Simulation of Progressive Failure of Woven Composites Engineering, to be presented at ICCE/5 Fifth International Conference on Composites Engineering, Las Vegas, NV, July 5-11, 1998.
11. Whitcomb, J.D.; Tang, X.; and Chapman, C.: Comparison of Stress Concentrations in Plain and Satin Weave Composites, to be presented at the International Mechanical Engineering Congress and Exposition, Dallas, TX, Nov. 1998.

# REPORT OF INVENTIONS AND SUBCONTRACTS

(Pursuant to "Patent Rights" Contract Clause) (See Instructions on Reverse Side.)

Form Approved  
OMB No. 0704-0297  
Expires Jun 30, 1992

Public reporting burden for this collection of information is estimated to average 5 minutes per response, including the time for reviewing instructions, searching existing data sources, gathering and maintaining the data needed, and completing and reviewing the collection of information. Send comments regarding this burden estimate or any other aspect of this collection of information, including suggestions for reducing this burden, to Washington Headquarters Services, Directorate for Information Operations and Reports, 1215 Jefferson Davis Highway, Suite 1204, Arlington, VA 22202-4302, and to the Office of Management and Budget, Paperwork Reduction Project (0704-0297), Washington, DC 20503.

<b>1a. NAME OF CONTRACTOR/SUBCONTRACTOR</b> John Whitcomb	<b>3a. NAME OF GOVERNMENT PRIME CONTRACTOR</b>	<b>3. TYPE OF REPORT (X one)</b> <input checked="" type="checkbox"/> a. INTERIM <input type="checkbox"/> b. FINAL
<b>b. ADDRESS (include ZIP Code)</b> Aerospace Engr., MS 3141 College Station, TX 77843	<b>c. CONTRACT NUMBER</b> F49620-94-1-0259	<b>4. REPORTING PERIOD (YYMMDD)</b> a. FROM b. TO
<b>d. AWARD DATE (YYMMDD)</b>		<b>d. AWARD DATE (YYMMDD)</b>

### SECTION I - SUBJECT INVENTIONS

**5. "SUBJECT INVENTIONS" REQUIRED TO BE REPORTED BY CONTRACTOR/SUBCONTRACTOR (If "None," so state)**

a. NAME(S) OF INVENTOR(S) (Last, First, MI)	b. TITLE OF INVENTION(S)	c. DISCLOSURE NO., PATENT APPLICATION SERIAL NO. OR PATENT NO.	d. ELECTION TO FILE PATENT APPLICATIONS	e. CONFIRMATORY INSTRUMENT OR ASSIGNMENT FORWARDED TO CONTRACTING OFFICER
NONE			(1) United States (a) Yes (b) No	(1) Yes (2) No
<b>9. ELECTED FOREIGN COUNTRIES IN WHICH A PATENT APPLICATION WILL BE FILED</b>				
(1) Title of invention				
(2) Foreign Countries of Patent Application				

**6. SUBCONTRACTS AWARDED BY CONTRACTOR/SUBCONTRACTOR (If "None," so state)**

a. NAME OF SUBCONTRACTOR(S)	b. ADDRESS (include ZIP Code)	c. SUBCONTRACT NO.(S)	d. DFR "PATENT RIGHTS"	e. DESCRIPTION OF WORK TO BE PERFORMED UNDER SUBCONTRACT(S)
			(1) Clause Number    (2) Date (YYMM)	(1) Award    (2) Estimated Completion

### SECTION II - SUBCONTRACTS (Containing a "Patent Rights" clause)

**7. CERTIFICATION OF REPORT BY CONTRACTOR/SUBCONTRACTOR**

**a. NAME OF AUTHORIZED CONTRACTOR/SUBCONTRACTOR OFFICIAL (Last, First, MI)**  
John Whitcomb

**b. TITLE**  
Professor

**d. SIGNATURE**

**e. DATE SIGNED**

### SECTION III - CERTIFICATION

**(Not required if Small Business or Non-Profit organization.) (X appropriate box)**

**c. I certify that the reporting party has procedures for prompt identification and timely disclosure of "Subject Inventions," that such procedures have been followed and that all "Subject Inventions" have been reported.**

## **Derivation of Boundary Conditions for Micromechanics Analyses of Plain and Satin Weave Composites**

John D. Whitcomb

Clinton D. Chapman

Xiaodong Tang

### **Abstract**

Efficient 3D analysis of periodic structures depends on identifying the smallest region to be modeled and the appropriate boundary conditions. This paper describes systematic procedures for deriving the boundary conditions for general periodic structures. These procedures are then used to derive the boundary conditions for plain and satin weave composites.

### **Introduction**

Composite materials consist of a combination of materials, often fibers and matrix. The basic challenge of micromechanics is to determine how the properties and spatial distribution of the constituents affect the overall material response. The overall response is often characterized in terms of the effective engineering properties, such as extensional moduli and Poisson's ratio. These are also referred to as the homogenized engineering properties. To obtain these properties a representative volume element (RVE) or unit cell is identified that includes all characteristics of the composite. The literature includes a wide variety of analyses for various unit cells. For example, some of the recent numerical studies have focused on hexagonal and square arrays of fibers in matrix [1-4], spherical inclusions in matrix [5], and textile composites [6-13]. The latter configuration, textile composites, presents a severe challenge to the analyst because of the geometric complexity. Although a variety of analyses exist, including some very detailed three-dimensional finite element analyses [7-13], there has not been a systematic description of how one obtains the boundary conditions to perform the analysis of textile composites. Reference [14] gives an excellent discussion of exploiting symmetry in general. However, the reference does not consider periodicity explicitly or composites. Accordingly, the goal of this paper is to present a systematic procedure for deriving the boundary conditions for both full unit cell and partial unit cell analyses of plain and satin weave composites.

## Background

Implicit in micromechanics analyses is that a small region of the microstructure fully represents the behavior of a much larger region (usually an infinite domain). There is no standard definition of this region in the literature. Herein, the term "unit cell" is defined to mean the smallest region that represents the behavior of the larger region without any mirroring or rotation transformations. For such a region to exist there must be a basic pattern (of geometry and response, such as strains, stresses, etc.) that is repeated periodically throughout a domain. In particular, the larger region can be synthesized by replication and translation of the unit cell in the three coordinate directions. Figure 1 shows examples of periodic microstructure. In each case, the region is built from a single building block or unit cell. Note that there can be more than one definition of the unit cell for a single microstructure (e.g. case (a) in Figure 1).

To determine effective engineering properties, the periodic array is subjected to a series of loads consisting of either macroscopically constant strain or stress. The term *macroscopically constant* indicates that the volume averaged strain for every unit cell is identical. (The same can be said for the stresses.) Although one cannot analyze an infinite number of unit cells, it is possible to derive boundary conditions for a single unit cell that will make it behave as though it is buried within an infinite array. How this is done will be described herein.

It is convenient to think of the challenge as consisting of two parts. The first part consists of identifying the appropriate boundary conditions for a single full unit cell. The second challenge is to exploit the symmetries in the microstructure of the unit cell and the loading to reduce the analysis region to just a fraction of the full cell in order to reduce the computational costs.

## Derivation of basic equations

The derivation of the boundary conditions is based on two conditions. The first is periodicity and the second is equivalence of coordinate system. It should be noted that that these concepts can be combined, but the authors choose not to do so. The periodic conditions state that the displacements in the various unit cells differ only by constant offsets that depend on the

volume averaged displacement gradients. Further, the strains and stresses are identical in all of the unit cells. This can be expressed as

$$\begin{aligned} u_i(x_\alpha + d_\alpha) &= u_i(x_\alpha) + \left\langle \frac{\partial u_i}{\partial x_\beta} \right\rangle d_\beta \\ \varepsilon_{ij}(x_\alpha + d_\alpha) &= \varepsilon_{ij}(x_\alpha) \\ \sigma_{ij}(x_\alpha + d_\alpha) &= \sigma_{ij}(x_\alpha) \end{aligned} \quad (1)$$

where  $d_\beta$  is a vector of periodicity. This vector is a vector from a point in one unit cell to an equivalent point in another unit cell.

These conditions are sufficient for deriving the boundary conditions for the full unit cell. However, it is usually desirable to exploit symmetries in order to be able to analyze a smaller region. The concept of "Equivalent Coordinate Systems" (ECS) is useful in identifying the symmetries and constraint conditions. Coordinate systems are equivalent if the geometry, spatial distribution of material, loading, and the various fields that describe the response (e.g. displacement, strains, etc.) are identical in the two systems.

For example,  $x_i$  and  $\bar{x}_i$  are equivalent coordinate systems if

$$\begin{aligned} \bar{u}_i(\bar{x}_\alpha) &= u_i(x_\alpha) \\ \bar{\varepsilon}_{ij}(\bar{x}_\alpha) &= \varepsilon_{ij}(x_\alpha) \\ \bar{\sigma}_{ij}(\bar{x}_\alpha) &= \sigma_{ij}(x_\alpha) \\ &\vdots \\ &\text{etc.} \end{aligned} \quad (2)$$

A visual technique for determining whether a new coordinate system is equivalent is to draw it on a three-dimensional view of the body. This view should include the load vectors and a description of the spatial variation of the material properties. If the body can be rotated (i.e. the view changed) such that the new view and new coordinate system look identical to the original view and coordinate system, the coordinate system is equivalent.

Exploiting equivalent coordinate systems requires identification of coordinate transformations that provide useful constraint conditions. Consider the equivalent coordinate system  $\bar{x}_i$  as a

potentially useful ECS. Define:  $a_{ij}$  = direction cosines for transformation from the original ( $x_j$ ) to the equivalent ( $\bar{x}_i$ ) coordinate system...i.e.  $\bar{x}_i = a_{ij} x_j$

$$\begin{aligned}\bar{u}_i(\bar{x}_\alpha) &= a_{ij} u_j(\bar{x}_\alpha) \\ \bar{\varepsilon}_{ij}(\bar{x}_\alpha) &= a_{im} a_{jn} \varepsilon_{mn}(\bar{x}_\alpha) \\ \bar{\sigma}_{ij}(\bar{x}_\alpha) &= a_{im} a_{jn} \sigma_{mn}(\bar{x}_\alpha)\end{aligned}\quad (3)$$

Combine equations (2) and (3) to give

$$\begin{aligned}u_i(x_\alpha) &= a_{ij} u_j(\bar{x}_\alpha) \\ \varepsilon_{ij}(x_\alpha) &= a_{im} a_{jn} \varepsilon_{mn}(\bar{x}_\alpha) \\ \sigma_{ij}(x_\alpha) &= a_{im} a_{jn} \sigma_{mn}(\bar{x}_\alpha)\end{aligned}\quad (4)$$

Finally, replace  $\bar{x}_\alpha$  with  $a_{\alpha j} x_j$  so that everything is now expressed in terms of a single coordinate system.

$$\begin{aligned}u_i(x_\alpha) &= a_{ij} u_j(a_{\alpha j} x_j) \\ \varepsilon_{ij}(x_\alpha) &= a_{im} a_{jn} \varepsilon_{mn}(a_{\alpha j} x_j) \\ \sigma_{ij}(x_\alpha) &= a_{im} a_{jn} \sigma_{mn}(a_{\alpha j} x_j)\end{aligned}\quad (5)$$

Sometimes it is necessary to switch the sign of all of the loads to make the two coordinate systems equivalent. If tension and compression properties are different, one must not switch the sign of the load to obtain an equivalent coordinate system.

To generalize equations (5), a factor  $\gamma$  is introduced.

$\gamma = 1$  if load reversal is not required

$\gamma = -1$  if load reversal is required

Equation (5) then becomes

$$\begin{aligned}u_i(x_\alpha) &= \gamma a_{ij} u_j(a_{\alpha j} x_j) \\ \varepsilon_{ij}(x_\alpha) &= \gamma a_{im} a_{jn} \varepsilon_{mn}(a_{\alpha j} x_j) \\ \sigma_{ij}(x_\alpha) &= \gamma a_{im} a_{jn} \sigma_{mn}(a_{\alpha j} x_j)\end{aligned}\quad (6)$$

The constraints that are implied by equations (6) are very useful in deriving the required boundary conditions. This will be demonstrated later through examples.

The value of the factor  $\gamma$  is easily determined from the loading, since only simple loading is considered. In particular, the model is subjected to either macroscopically constant strain or stress. For example, one might specify a volume-averaged value of  $\sigma_{12}$  (with the other volume-averaged stresses=0). The sign of  $\gamma$  can be obtained by examining the effect of the coordinate transformation on the sign of  $\sigma_{12}$ . In fact, we can consider all six load cases at once. For example, if the coordinate transformation is mirroring about the  $x_1=0$  plane,

$$a_{ij} = \begin{bmatrix} -1 & 0 & 0 \\ 0 & 1 & 0 \\ 0 & 0 & 1 \end{bmatrix} \quad \text{which gives} \quad a_{im} a_{jn} \sigma_{mn} = \begin{bmatrix} \sigma_{11} & -\sigma_{12} & -\sigma_{13} \\ -\sigma_{12} & \sigma_{22} & \sigma_{23} \\ -\sigma_{13} & \sigma_{23} & \sigma_{33} \end{bmatrix}$$

Accordingly, the values of  $\gamma$  are as follows for the six different load conditions for mirroring about the  $x_1=0$  plane.

$$\begin{array}{ccccccc} \text{Stress} & \sigma_{11} & \sigma_{22} & \sigma_{33} & \sigma_{12} & \sigma_{23} & \sigma_{13} \\ \gamma & 1 & 1 & 1 & -1 & 1 & -1 \end{array}$$

The values of  $\gamma$  for six different coordinate transformations and the six load cases are summarized in Table 1 below. The values of  $\gamma$  for specified strains  $\varepsilon_{ij}$  or displacement gradients  $\frac{\partial u_i}{\partial x_j}$  are the same as for stress loading.

Table 1 Values of  $\gamma$  for various transformations and load cases.

Transformation	Load Case					
	$\sigma_{11}$	$\sigma_{22}$	$\sigma_{33}$	$\sigma_{12}$	$\sigma_{23}$	$\sigma_{13}$
Mirror about $x_1=0$	1	1	1	-1	1	-1
Mirror about $x_2=0$	1	1	1	-1	-1	1
Mirror about $x_3=0$	1	1	1	1	-1	-1
$\pi$ rotation about $x_1$	1	1	1	-1	1	-1
$\pi$ rotation about $x_2$	1	1	1	-1	-1	1
$\pi$ rotation about $x_3$	1	1	1	1	-1	-1

The values of  $\gamma$  also indicate what types of loading can exist for a particular type of equivalent coordinate system. For example, for mirroring about the  $x_1$  axis one cannot impose non-zero volume averaged values of both  $\varepsilon_{11}$  and  $\varepsilon_{12}$  at the same time ... the symmetries are incompatible since they require different values of  $\gamma$ . Furthermore, if one imposes a non-zero  $\langle \varepsilon_{11} \rangle$  and retains the other strains as unknowns to be determined as part of the solution,  $\langle \varepsilon_{12} \rangle$  and  $\langle \varepsilon_{13} \rangle$  must be found to be zero.

### Boundary conditions for symmetrically stacked plain weave

If one is willing to analyze the entire unit cell, the periodic conditions for the displacements can be used to specify the boundary conditions. However, to reduce the region to be analyzed requires a bit more effort. The following describes a systematic way to go about accomplishing this task. Although the focus is on the plain weave, the techniques are quite general. Figure 2a is a unit cell for a symmetrically stacked plain weave composite. As can be seen from the figure, the planes  $x_1 = 0$  are planes of geometric symmetry.

The first step will be to develop relationships for the planes  $x_1 = \pm a$ . (vector of periodicity  $d_a = [2a, 0, 0]$ ) Substituting  $x_1 = -a$  into the periodic relations gives

$$\begin{aligned} u_i(a, x_2, x_3) &= u_i(-a, x_2, x_3) + \left\langle \frac{\partial u_i}{\partial x_1} \right\rangle 2a \\ \varepsilon_{ij}(a, x_2, x_3) &= \varepsilon_{ij}(-a, x_2, x_3) \\ \sigma_{ij}(a, x_2, x_3) &= \sigma_{ij}(-a, x_2, x_3) \end{aligned} \quad (7)$$

Consider the equivalent coordinate system (ECS)  $\bar{x}_\alpha$  that is obtained by mirroring about  $x_1 = 0$ . The direction cosines for this transformation are

$$a_{ij} = \begin{bmatrix} -1 & 0 & 0 \\ 0 & 1 & 0 \\ 0 & 0 & 1 \end{bmatrix} \quad (8)$$

Substituting the  $a_{ij}$  above into equations (6) yields the following relationships for displacements and stresses,

$$\begin{bmatrix} u_1 \\ u_2 \\ u_3 \end{bmatrix}_{(a, x_2, x_3)} = \gamma \begin{bmatrix} -u_1 \\ u_2 \\ u_3 \end{bmatrix}_{(-a, x_2, x_3)}$$

$$\begin{bmatrix} \sigma_{11} & \sigma_{12} & \sigma_{13} \\ \sigma_{12} & \sigma_{22} & \sigma_{23} \\ \sigma_{13} & \sigma_{23} & \sigma_{33} \end{bmatrix}_{(a, x_2, x_3)} = \begin{bmatrix} \sigma_{11} & -\sigma_{12} & -\sigma_{13} \\ -\sigma_{12} & \sigma_{22} & \sigma_{23} \\ -\sigma_{13} & \sigma_{23} & \sigma_{33} \end{bmatrix}_{(-a, x_2, x_3)} \quad (9)$$

Tractions will transform like the displacements and strains like the stresses, so the details are not shown. These periodic and ECS conditions will now be combined ... first for displacements and then for the stresses.

### Displacements

Combining the constraints in equations (7) and (9) yields:

$$\begin{bmatrix} u_1 \\ u_2 \\ u_3 \end{bmatrix}_{(-a, x_2, x_3)} + \begin{bmatrix} \left\langle \frac{\partial u_1}{\partial x_1} \right\rangle \\ \left\langle \frac{\partial u_2}{\partial x_1} \right\rangle \\ \left\langle \frac{\partial u_3}{\partial x_1} \right\rangle \end{bmatrix} 2a = \gamma \begin{bmatrix} -u_1 \\ u_2 \\ u_3 \end{bmatrix}_{(-a, x_2, x_3)} \quad (10)$$

Rearranging, yields

$$\begin{bmatrix} u_1(1+\gamma) \\ u_2(1-\gamma) \\ u_3(1-\gamma) \end{bmatrix}_{(-a, x_2, x_3)} = - \begin{bmatrix} \left\langle \frac{\partial u_1}{\partial x_1} \right\rangle \\ \left\langle \frac{\partial u_2}{\partial x_1} \right\rangle \\ \left\langle \frac{\partial u_3}{\partial x_1} \right\rangle \end{bmatrix} 2a \quad (11)$$

Recall that the value of  $\gamma$  depends on whether the loads must be reversed for the new coordinate system to be equivalent. The constraints indicated by equation (11) are listed below. The ones that provide useful information are boxed. The remaining constraints are not useful for performing the analysis, but they can be used for evaluating the results.

$$\begin{array}{ccc}
 \gamma = 1 & & \gamma = -1 \\
 \hline \hline
 \boxed{u_1(-a, x_2, x_3) = -\left\langle \frac{\partial u_1}{\partial x_1} \right\rangle a} & & \left\langle \frac{\partial u_1}{\partial x_1} \right\rangle = 0 \\
 \left\langle \frac{\partial u_2}{\partial x_1} \right\rangle = 0 & & \boxed{u_2(-a, x_2, x_3) = -\left\langle \frac{\partial u_2}{\partial x_1} \right\rangle a} \\
 \left\langle \frac{\partial u_3}{\partial x_1} \right\rangle = 0 & & \boxed{u_3(-a, x_2, x_3) = -\left\langle \frac{\partial u_3}{\partial x_1} \right\rangle a}
 \end{array} \tag{12}$$

This can be expressed quite succinctly as follows

- If  $\gamma = 1$ , normal displacements on  $x_1 = -a$  are equal. Because of periodicity, the normal displacements on  $x_1 = a$  are also equal and opposite those on  $x_1 = -a$ .
- If  $\gamma = -1$ , tangential displacements are constant in each direction on  $x_1 = -a$ . Because of periodicity, the tangential displacements in each direction on  $x_1 = a$  are also equal and opposite the corresponding displacements on  $x_1 = -a$ .

### Stresses

Now consider the constraints on the stresses. Combine equations (7) and (9) to obtain the following useful relations (the remainder are trivially satisfied or do not affect the boundary conditions.)

$$\begin{array}{ll}
 \gamma = 1: & \sigma_{12}(\pm a, x_2, x_3) = 0 & \sigma_{13}(\pm a, x_2, x_3) = 0 \\
 \gamma = -1: & \sigma_{11}(\pm a, x_2, x_3) = 0 & 
 \end{array} \tag{13}$$

These can be summarized as follows (using Cauchy's stress formula,  $\tau_i = \sigma_{ji}n_j$ )

- If  $\gamma = 1$  shear traction on  $x_1 = \pm a$  is zero

- If  $\gamma = -1$  normal traction on  $x_1 = \pm a$  is zero

Because of the symmetries in the microstructure, we will obtain analogous results for  $x_2 = \pm a$  and  $x_3 = \pm t$ . That is, on these planes

- If  $\gamma = 1$ , normal displacements are equal, and shear tractions are zero.
- If  $\gamma = -1$ , tangential displacements are equal, and normal tractions are zero.

Next we proceed to exploit symmetries within the cell to reduce the region which must be modeled. Again, we will consider an ECS obtained by mirroring about the  $x_1 = 0$  plane. However, this time we examine the displacements, etc., along the plane  $x_1 = 0$ . Equations (6) become

$$\begin{bmatrix} u_1 \\ u_2 \\ u_3 \end{bmatrix}_{(0, x_2, x_3)} = \gamma \begin{bmatrix} -u_1 \\ u_2 \\ u_3 \end{bmatrix}_{(0, x_2, x_3)} \quad \text{and} \quad \begin{bmatrix} \sigma_{11} & \sigma_{12} & \sigma_{13} \\ \sigma_{12} & \sigma_{22} & \sigma_{23} \\ \sigma_{13} & \sigma_{23} & \sigma_{33} \end{bmatrix}_{(0, x_2, x_3)} = \gamma \begin{bmatrix} \sigma_{11} & -\sigma_{12} & -\sigma_{13} \\ -\sigma_{12} & \sigma_{22} & \sigma_{23} \\ -\sigma_{13} & \sigma_{23} & \sigma_{33} \end{bmatrix}_{(0, x_2, x_3)} \quad (14)$$

Therefore, on  $x_1 = 0$  we have the following constraints

$$\begin{array}{ll} \gamma = 1 & \gamma = -1 \\ \text{normal displacement} = 0 & \text{tangential displacements} = 0 \\ \text{tangential tractions} = 0 & \text{normal tractions} = 0 \end{array} \quad (15)$$

If we repeat this exercise for the planes  $x_2 = 0$  and  $x_3 = 0$  (which are also planes of microstructural symmetry), we will obtain analogous results. We are now down to 1/8 of the original unit cell (Figure 2(b)). The analysis region can be reduced to 1/32 of the unit cell. To simplify the derivation of the boundary conditions for the 1/32 unit cell, the coordinate system origin is shifted to the center of the 1/8 unit cell (Figure 2(c)).

Consider a rotation about the  $x_1$  axis of  $180^\circ$  to obtain an ECS.

$$a_{ij} = \begin{bmatrix} 1 & 0 & 0 \\ 0 & -1 & 0 \\ 0 & 0 & -1 \end{bmatrix} \quad (16)$$

The periodic conditions in equation (6) yield (specialized for  $x_2 = 0$ ).

$$\begin{bmatrix} u_1 \\ u_2 \\ u_3 \end{bmatrix}_{(x_1, 0, x_3)} = \gamma \begin{bmatrix} u_1 \\ -u_2 \\ -u_3 \end{bmatrix}_{(x_1, 0, -x_3)}$$

$$\begin{bmatrix} \sigma_{11} & \sigma_{12} & \sigma_{13} \\ \sigma_{12} & \sigma_{22} & \sigma_{23} \\ \sigma_{13} & \sigma_{23} & \sigma_{33} \end{bmatrix}_{(x_1, 0, x_3)} = \begin{bmatrix} \sigma_{11} & -\sigma_{12} & -\sigma_{13} \\ -\sigma_{12} & \sigma_{22} & \sigma_{23} \\ -\sigma_{13} & \sigma_{23} & \sigma_{33} \end{bmatrix}_{(x_1, 0, -x_3)} \quad (17)$$

The results in the following displacement constraints

$$\begin{array}{l} \gamma = 1 \\ \hline u_1(x_1, 0, x_3) = u_1(x_1, 0, -x_3) \\ u_2(x_1, 0, x_3) = -u_2(x_1, 0, -x_3) \\ u_3(x_1, 0, x_3) = -u_3(x_1, 0, -x_3) \end{array} \quad \begin{array}{l} \gamma = -1 \\ \hline u_1(x_1, 0, x_3) = -u_1(x_1, 0, -x_3) \\ u_2(x_1, 0, x_3) = u_2(x_1, 0, -x_3) \\ u_3(x_1, 0, x_3) = u_3(x_1, 0, -x_3) \end{array} \quad (18)$$

Note that constraints are derived for all three-displacement components. Hence, traction boundary conditions do not have to be considered. Now one can replace the region  $x_2 > 0$  with these constraints. The analysis region is now 1/16 of the unit cell.

Now consider a rotation about the  $x_2$  axis of  $180^\circ$  to obtain an ECS and specialize equation (6) for the plane  $x_1 = 0$ .

$$a_{ij} = \begin{bmatrix} -1 & 0 & 0 \\ 0 & 1 & 0 \\ 0 & 0 & -1 \end{bmatrix} \quad (19)$$

The result is

$$\begin{bmatrix} u_1 \\ u_2 \\ u_3 \end{bmatrix}_{(0, x_2, x_3)} = \gamma \begin{bmatrix} -u_1 \\ u_2 \\ -u_3 \end{bmatrix}_{(0, x_2, -x_3)}$$

$$\begin{bmatrix} \sigma_{11} & \sigma_{12} & \sigma_{13} \\ \sigma_{12} & \sigma_{22} & \sigma_{23} \\ \sigma_{13} & \sigma_{23} & \sigma_{33} \end{bmatrix}_{(0,x_2,x_3)} = \gamma \begin{bmatrix} \sigma_{11} & -\sigma_{12} & \sigma_{13} \\ -\sigma_{12} & \sigma_{22} & -\sigma_{23} \\ \sigma_{13} & -\sigma_{23} & \sigma_{33} \end{bmatrix}_{(0,x_2,-x_3)} \quad (20)$$

This results in the following displacement constraints

$$\begin{array}{ccc} \gamma = 1 & & \gamma = -1 \\ \hline u_1(0, x_2, x_3) = -u_1(0, x_2, -x_3) & & u_1(0, x_2, x_3) = u_1(0, x_2, -x_3) \\ u_2(0, x_2, x_3) = u_2(0, x_2, -x_3) & & u_2(0, x_2, x_3) = -u_2(0, x_2, -x_3) \\ u_3(0, x_2, x_3) = -u_3(0, x_2, -x_3) & & u_3(0, x_2, x_3) = u_3(0, x_2, -x_3) \end{array} \quad (21)$$

Again, one obtains constraints for all three-displacement components. Hence, the region  $x_1 > 0$  can be reduced with these constraints, leaving an analysis region of only 1/32 of the unit cell.

Table 2 summarizes the boundary conditions for symmetrically and simply stacked plain weaves under extension,  $\sigma_{12}$  (or  $\varepsilon_{12}$ ) shear, and  $\sigma_{13}$  (or  $\varepsilon_{13}$ ) shear load conditions.

#### Boundary conditions for satin weave

The boundary conditions for a simply stacked 8-harness satin weave (Figure 3) will be derived in this section. Modifications for a symmetrically stacked satin weave are also given. If the entire unit cell is to be analyzed, the periodic conditions given in equation (1) are sufficient. The vectors of periodicity to be used in equation (1) are  $[3a, -a, 0]$ ,  $[2a, 2a, 0]$ ,  $[-a, 3a, 0]$ ,  $[0, 0, t]$ . However, it is possible to analyze half of the unit cell if both the periodicity and an equivalent coordinate system are exploited. The half-cell that will eventually be used is shown in Figure 3(b). The equivalent coordinate system to be used is obtained by a rotation of  $\pi$  about the  $x_3$  axis. For such a transformation equation (6) gives the following constraints for the full unit cell.

$$\begin{array}{l} u_1(x_1, x_2, x_3) = -u_1(-x_1, -x_2, x_3) \\ u_2(x_1, x_2, x_3) = -u_2(-x_1, -x_2, x_3) \\ u_3(x_1, x_2, x_3) = u_3(-x_1, -x_2, x_3) \end{array} \quad (22)$$

Boundary conditions for the plane  $x_2 = 0$  can be obtained immediately by substituting  $x_2 = 0$  into equation (22). Equation (22) will also be useful later as each pair of faces of the unit

cell is considered. Suitable constraints must be derived for the other faces in order to reduce the analysis region to one-half of the unit cell.

$$\text{Faces } x_1 = \pm \frac{3a}{2}$$

The vector of periodicity that connects these faces is  $d_a = [3a, -a, 0]$ . Substitution of this vector into equation (1) gives

$$u_i\left(\frac{3a}{2}, x_2 - a, x_3\right) = u_i\left(-\frac{3a}{2}, x_2, x_3\right) + 3a\left\langle \frac{\partial u_i}{\partial x_1} \right\rangle - a\left\langle \frac{\partial u_i}{\partial x_2} \right\rangle, \quad i = 1, 2, 3 \quad (23)$$

$$\text{where } -\frac{a}{2} \leq x_2 \leq \frac{3a}{2}.$$

The constraints in equation (23) are used to specify the boundary conditions for the shaded regions in Figure 4(a).

Combining equation (22) and (23), gives boundary conditions for the face  $x_1 = \frac{3a}{2}$  as

follows:

$$\begin{aligned} u_1\left(\frac{3a}{2}, x_2 - a, x_3\right) &= -\gamma u_1\left(\frac{3a}{2}, -x_2, x_3\right) + 3a\left\langle \frac{\partial u_1}{\partial x_1} \right\rangle - a\left\langle \frac{\partial u_1}{\partial x_2} \right\rangle \\ u_2\left(\frac{3a}{2}, x_2 - a, x_3\right) &= -\gamma u_2\left(\frac{3a}{2}, -x_2, x_3\right) + 3a\left\langle \frac{\partial u_2}{\partial x_1} \right\rangle - a\left\langle \frac{\partial u_2}{\partial x_2} \right\rangle \\ u_3\left(\frac{3a}{2}, x_2 - a, x_3\right) &= \gamma u_3\left(\frac{3a}{2}, -x_2, x_3\right) + 3a\left\langle \frac{\partial u_3}{\partial x_1} \right\rangle - a\left\langle \frac{\partial u_3}{\partial x_2} \right\rangle \end{aligned} \quad (24)$$

where  $-\frac{a}{2} \leq x_2 \leq \frac{3a}{2}$ . Note that these constraints only involve points on the plane  $x_1 = \frac{3a}{2}$ .

Equation (24) is used to specify the boundary conditions for the points specified by  $0 \leq x_2 \leq a$  in equation (24). (shaded region in Figure 4(b)).

Faces  $x_1 + x_2 = \pm 2a$  (beveled edges)

The vector of periodicity that connects these faces is  $d_a = [2a, 2a, 0]$ . Substitution of this vector into equation (1) gives

$$u_i(-x_2, x_2 + 2a, x_3) = u_i(-x_2 - 2a, x_2, x_3) + 2a \left\langle \frac{\partial u_i}{\partial x_1} \right\rangle + 2a \left\langle \frac{\partial u_i}{\partial x_2} \right\rangle, \quad i = 1, 2, 3 \quad (25)$$

Combining equation (25) and the equivalent coordinate system (22) gives the following boundary conditions for face  $x_1 + x_2 = -2a$ .

$$\begin{aligned} -\gamma u_1(x_2, -x_2 - 2a, x_3) &= u_1(-x_2 - 2a, x_2, x_3) + 2a \left\langle \frac{\partial u_1}{\partial x_1} \right\rangle + 2a \left\langle \frac{\partial u_1}{\partial x_2} \right\rangle \\ -\gamma u_2(x_2, -x_2 - 2a, x_3) &= u_2(-x_2 - 2a, x_2, x_3) + 2a \left\langle \frac{\partial u_2}{\partial x_1} \right\rangle + 2a \left\langle \frac{\partial u_2}{\partial x_2} \right\rangle \\ \gamma u_3(x_2, -x_2 - 2a, x_3) &= u_3(-x_2 - 2a, x_2, x_3) + 2a \left\langle \frac{\partial u_3}{\partial x_1} \right\rangle + 2a \left\langle \frac{\partial u_3}{\partial x_2} \right\rangle \end{aligned} \quad (26)$$

where  $-\frac{3a}{2} \leq x_2 \leq -\frac{a}{2}$ . The constraints in equation (26) only involve points on the plane  $x_1 + x_2 = -2a$ . This can be verified by observing that the coordinates satisfy the condition  $x_1 + x_2 = -2a$ . Similar boundary conditions can also be obtained for face  $x_1 + x_2 = 2a$ , but they are not needed for the half unit cell.

$$\text{Faces } x_2 = \pm \frac{3a}{2}$$

The vector of periodicity that connects these faces is  $d_a = [-a, 3a, 0]$ . Substitution of this vector into equation (1) gives

$$u_i\left(x_1, \frac{3a}{2}, x_3\right) = u_i\left(x_1, -\frac{3a}{2}, x_3\right) - a \left\langle \frac{\partial u_i}{\partial x_1} \right\rangle + 3a \left\langle \frac{\partial u_i}{\partial x_2} \right\rangle, \quad i = 1, 2, 3 \quad (27)$$

Combining equation (27) and the equivalent coordinate system (22) gives the following boundary conditions for face  $x_2 = -\frac{3a}{2}$

$$\begin{aligned}
-\gamma_1 \left( -x_1 + a, -\frac{3a}{2}, x_3 \right) &= u_1 \left( x_1, -\frac{3a}{2}, x_3 \right) - a \left\langle \frac{\partial u_1}{\partial x_1} \right\rangle + 3a \left\langle \frac{\partial u_1}{\partial x_2} \right\rangle \\
-\gamma_2 \left( -x_1 + a, -\frac{3a}{2}, x_3 \right) &= u_2 \left( x_1, -\frac{3a}{2}, x_3 \right) - a \left\langle \frac{\partial u_2}{\partial x_1} \right\rangle + 3a \left\langle \frac{\partial u_2}{\partial x_2} \right\rangle \\
\gamma_3 \left( -x_1 + a, -\frac{3a}{2}, x_3 \right) &= u_3 \left( x_1, -\frac{3a}{2}, x_3 \right) - a \left\langle \frac{\partial u_3}{\partial x_1} \right\rangle + 3a \left\langle \frac{\partial u_3}{\partial x_2} \right\rangle
\end{aligned} \tag{28}$$

where  $-\frac{a}{2} \leq x_1 \leq \frac{3a}{2}$ . Similar boundary conditions can also be obtained for face  $x_2=3a/2$ , but they are not needed herein.

Faces  $x_3 = \pm \frac{t}{2}$

The vector of periodicity that connects these faces is  $d_a = [0, 0, t]$ . Substitution of this vector into equation (1) gives

$$u_i \left( x_1, x_2, \frac{t}{2} \right) = u_i \left( x_1, x_2, -\frac{t}{2} \right) + t \left\langle \frac{\partial u_i}{\partial x_3} \right\rangle, \quad i = 1, 2, 3 \tag{29}$$

Up to this point the boundary conditions described have been valid for both simple and symmetric stacking except equation (29) is valid for simple stacking only. For symmetric stacking, the boundary conditions on  $x_3 = \pm \frac{t}{2}$  are the same as for the symmetrically stacked plain weave discussed earlier, that is

- If  $\gamma = 1$ , normal displacements are equal, and shear tractions are zero.
- If  $\gamma = -1$ , tangential displacements are equal, and normal tractions are zero.

### Comments on boundary conditions

Earlier in the discussion of Table 1 it was mentioned that certain macroscopic modes of deformation are incompatible when transformations are used to reduce the analysis region to less than the full unit cell. Although all the macroscopic displacement gradients were listed in the boundary conditions, whenever a particular load case is considered, many of the gradients must be zero. Also, it is necessary to eliminate rigid body motion of the model. Rigid body

translations are prevented by constraining a single point in all three coordinate directions. Rigid body rotations are prevented by imposing

$$\left\langle \frac{\partial u_i}{\partial x_j} \right\rangle = \left\langle \frac{\partial u_j}{\partial x_i} \right\rangle \text{ for } i \neq j$$

This causes no loss of generality in the modes of deformation. The simplified boundary conditions for simply and symmetrically stacked 8-harness satin weaves are summarized in Table 3.

As listed, specifying the magnitude of the displacement gradients specifies the magnitude of the load. If one specifies one displacement gradient to be non-zero and the rest to be zero, then obviously there is only one non-zero volume averaged strain, but there are generally several non-zero volume averaged stresses. Conversely, if one displacement gradient is specified and the rest are determined as part of the solution, there will generally be several volume averaged strains, but only one volume averaged stress.

### Conclusions

A systematic procedure was developed for deriving boundary conditions for partial unit cell models of materials with periodic microstructure. The procedure combines the concepts of periodicity and equivalent coordinate systems. Boundary conditions were derived for simply and symmetrically stacked plain and 8-harness satin weave composites for various types of macroscopic loads.

### Acknowledgement

This material is based upon work supported by the AFOSR under Grant No. F49620-93-1-0471 and F49620-94-1-0259. Any opinions, findings, and conclusions or recommendations expressed in this publication are those of the author and do not necessarily reflect the views of the AFOSR.

**References**

- [1] Teply, J.L., Dvorak, G.J., 1988, " Bounds on Overall Instantaneous Properties of Elastic-Plastic Composites," *Journal of the Mechanics and Physics of Solids*, Vol. 36, pp. 29-58.
- [2] Brockenbrough, J.R., Suresh, S., Wienecke, H.A., 1991, "Deformation of Metal-Matrix Composites with Continuous Fibers: Geometrical Effects of Fiber Distribution and Shape," *Acta Metallurgica et Materialia*, Vol. 39, No. 5, pp. 735-752.
- [3] Sun, C.T., Vaidya, R.S., 1996, "Prediction of Composite Properties from a Representative Volume Element," *Composites Science and Technology*, Vol. 56, No. 2, pp. 171-179.
- [4] Cheng, C., Aravas, N., 1997, "Creep of Metal-Matrix Composites with Elastic Fibers - Part I: Continuous Aligned Fibers," *Journal of Solids and Structures*, Vol. 34, No. 31, pp. 4147-4171.
- [5] Wienecke, H.A., Brockenbrough, J.R., Romanko, A.D., 1995, "Three-Dimensional Unit Cell Model with Application Toward Particulate Composites," *Journal of Applied Mechanics, Transactions ASME*, Vol. 62, No. 1, pp. 136-140.
- [6] Marrey, R.V., Sankar, B.V., 1997, "Micromechanical Model for Textile Composite Plates," *Journal of Composite Materials*, Vol. 31, No. 12, pp. 1187-1213.
- [7] Whitcomb, J.D., 1991, "Three-Dimensional Stress Analysis of Plain Weave Composites," *Composite Materials: Fatigue and Fracture, Third Volume*, T.K. O'Brien, ed., ASTM STP-1110, pp. 417-438.
- [8] Dasgupta, A., Agarwal, R.K., 1992, "Orthotropic Thermal Conductivity of Plain-Weave Fabric Composites Using Homogenization Technique," *Journal of Composite Materials*, Vol. 26, pp. 2736-2758.
- [9] Dasgupta, A., Agarwal, R.K., Bhandarkar, S.M., 1996, "Three-Dimensional Modeling of Woven-Fabric Composites for Effective Thermo-Mechanical and Thermal Properties," *Composites Science and Technology*, Vol. 56, No. 3, pp. 209-223.
- [10] Paumelle, P., Hassim, A., Léné, F., 1991, "Microstress Analysis in Woven Composite Structures," *La Recherche Aérospatiale*, Vol. 6, pp. 47-62.
- [11] Chapman, C.D., 1993, "Effects of Assumed Tow Architecture on the Predicted Moduli and Stresses in Woven Composites," Master Thesis, Department of Aerospace Engineering, Texas A&M University, College Station, Texas.
- [12] Chapman, C.D., 1997, "Prediction of Moduli and Strength of Woven Carbon-Carbon Composites Using Object-Oriented Finite Element Analysis," Ph.D. Dissertation, Department of Aerospace Engineering, Texas A&M University, College Station, Texas.
- [13] Whitcomb, J.D., Chapman, C., 1998, "Analysis of Plain Weave Composites Subjected to

Flexure," *Mechanics of Composite Materials and Structures*, Vol. 5, No. 1, pp. 41-53.

[14] Glockner, P.G., 1973, "Symmetry in Structural Mechanics," *Journal of the Structural Division, Proc. ASCE*, Vol. 99, No. ST1, pp. 71-89.

Table 2 Summary of boundary conditions for plain weave

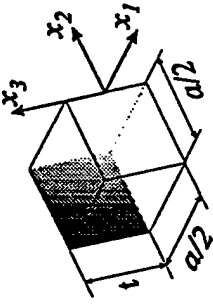
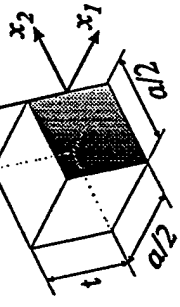
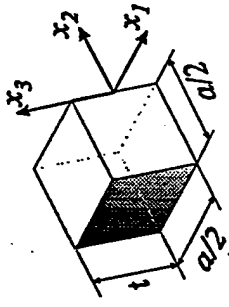
	Extensional Load in $x_1, x_2$ or $x_3$ directions	$\sigma_{12}$ (or $\epsilon_{12}$ ) Shear Load	$\sigma_{13}$ (or $\epsilon_{13}$ ) Shear Load
	$u_1\left(-\frac{a}{2}, x_2, x_3\right) = -\left\langle \frac{\partial u_1}{\partial x_1} \right\rangle \frac{a}{2}$ $t_2\left(-\frac{a}{2}, x_2, x_3\right) = 0$ $t_3\left(-\frac{a}{2}, x_2, x_3\right) = 0$	$t_1\left(-\frac{a}{2}, x_2, x_3\right) = 0$ $u_2\left(-\frac{a}{2}, x_2, x_3\right) = -\left\langle \frac{\partial u_2}{\partial x_1} \right\rangle \frac{a}{2}$ $u_3\left(-\frac{a}{2}, x_2, x_3\right) = 0$	$t_1\left(-\frac{a}{2}, x_2, x_3\right) = 0$ $u_2\left(-\frac{a}{2}, x_2, x_3\right) = 0$ $u_3\left(-\frac{a}{2}, x_2, x_3\right) = -\left\langle \frac{\partial u_3}{\partial x_1} \right\rangle \frac{a}{2}$
	$u_1(0, x_2, x_3) = -u_1(0, x_2, -x_3)$ $u_2(0, x_2, x_3) = u_2(0, x_2, -x_3)$ $u_3(0, x_2, x_3) = -u_3(0, x_2, -x_3)$	$u_1(0, x_2, x_3) = u_1(0, x_2, -x_3)$ $u_2(0, x_2, x_3) = -u_2(0, x_2, -x_3)$ $u_3(0, x_2, x_3) = u_3(0, x_2, -x_3)$	$u_1(0, x_2, x_3) = -u_1(0, x_2, -x_3)$ $u_2(0, x_2, x_3) = u_2(0, x_2, -x_3)$ $u_3(0, x_2, x_3) = -u_3(0, x_2, -x_3)$
	$t_1\left(x_1, -\frac{a}{2}, x_3\right) = 0$ $u_2\left(x_1, -\frac{a}{2}, x_3\right) = -\left\langle \frac{\partial u_2}{\partial x_2} \right\rangle \frac{a}{2}$ $t_3\left(x_1, -\frac{a}{2}, x_3\right) = 0$	$u_1\left(x_1, -\frac{a}{2}, x_3\right) = -\left\langle \frac{\partial u_1}{\partial x_1} \right\rangle \frac{a}{2}$ $t_2\left(x_1, -\frac{a}{2}, x_3\right) = 0$ $u_3\left(x_1, -\frac{a}{2}, x_3\right) = 0$	$t_1\left(x_1, -\frac{a}{2}, x_3\right) = 0$ $u_2\left(x_1, -\frac{a}{2}, x_3\right) = 0$ $t_3\left(x_1, -\frac{a}{2}, x_3\right) = 0$

	$u_1(x_1, 0, x_3) = u_1(x_1, 0, -x_3)$ $u_2(x_1, 0, x_3) = -u_2(x_1, 0, -x_3)$ $u_3(x_1, 0, x_3) = -u_3(x_1, 0, -x_3)$	$u_1(x_1, 0, x_3) = -u_1(x_1, 0, -x_3)$ $u_2(x_1, 0, x_3) = u_2(x_1, 0, -x_3)$ $u_3(x_1, 0, x_3) = u_3(x_1, 0, -x_3)$	$u_1(x_1, 0, x_3) = -u_1(x_1, 0, -x_3)$ $u_2(x_1, 0, x_3) = u_2(x_1, 0, -x_3)$ $u_3(x_1, 0, x_3) = u_3(x_1, 0, -x_3)$
	<p>Symmetric stacking</p> $t_1(x_1, x_2, \pm \frac{t}{2}) = 0$ $t_2(x_1, x_2, \pm \frac{t}{2}) = 0$ $u_3(x_1, x_2, \pm \frac{t}{2}) = \pm \left\langle \frac{\partial u_3}{\partial x_3} \right\rangle \frac{t}{2}$ <p>Simple stacking</p> $u_1(x_1, x_2, \frac{t}{2}) = u_1(x_1, x_2, -\frac{t}{2})$ $u_2(x_1, x_2, \frac{t}{2}) = u_2(x_1, x_2, -\frac{t}{2})$ $u_3(x_1, x_2, \frac{t}{2}) = u_3(x_1, x_2, -\frac{t}{2}) + \left\langle \frac{\partial u_3}{\partial x_3} \right\rangle t$	<p>Symmetric stacking</p> $t_1(x_1, x_2, \pm \frac{t}{2}) = 0$ $t_2(x_1, x_2, \pm \frac{t}{2}) = 0$ $u_3(x_1, x_2, \pm \frac{t}{2}) = 0$ <p>Simple stacking</p> $u_1(x_1, x_2, \frac{t}{2}) = u_1(x_1, x_2, -\frac{t}{2})$ $u_2(x_1, x_2, \frac{t}{2}) = u_2(x_1, x_2, -\frac{t}{2})$ $u_3(x_1, x_2, \frac{t}{2}) = u_3(x_1, x_2, -\frac{t}{2})$	<p>Symmetric stacking</p> $u_1(x_1, x_2, \pm \frac{t}{2}) = \pm \left\langle \frac{\partial u_3}{\partial x_1} \right\rangle \frac{t}{2}$ $u_2(x_1, x_2, \pm \frac{t}{2}) = 0$ $t_3(x_1, x_2, \pm \frac{t}{2}) = 0$ <p>Simple stacking</p> $u_1(x_1, x_2, \frac{t}{2}) = u_1(x_1, x_2, -\frac{t}{2}) + \left\langle \frac{\partial u_3}{\partial x_1} \right\rangle t$ $u_2(x_1, x_2, \frac{t}{2}) = u_2(x_1, x_2, -\frac{t}{2})$ $u_3(x_1, x_2, \frac{t}{2}) = u_3(x_1, x_2, -\frac{t}{2})$

Table 3 Summary of boundary conditions for 8-harness satin weave

	Extension in $x_1$ , $x_2$ and $x_3$ directions and / or $x_1x_2$ -shear load conditions	$x_1x_3$ -shear and / or $x_2x_3$ -shear load conditions
	$u_1\left(\frac{3a}{2}, x_2 - a, x_3\right) = u_1\left(-\frac{3a}{2}, x_2, x_3\right) + 3a\left\langle\frac{\partial u_1}{\partial x_1}\right\rangle - a\left\langle\frac{\partial u_1}{\partial x_2}\right\rangle$ $u_2\left(\frac{3a}{2}, x_2 - a, x_3\right) = u_2\left(-\frac{3a}{2}, x_2, x_3\right) + 3a\left\langle\frac{\partial u_2}{\partial x_1}\right\rangle - a\left\langle\frac{\partial u_2}{\partial x_2}\right\rangle$ $u_3\left(\frac{3a}{2}, x_2 - a, x_3\right) = u_3\left(-\frac{3a}{2}, -x_2, x_3\right)$	$u_1\left(\frac{3a}{2}, x_2 - a, x_3\right) = u_1\left(-\frac{3a}{2}, x_2, x_3\right)$ $u_2\left(\frac{3a}{2}, x_2 - a, x_3\right) = u_2\left(-\frac{3a}{2}, x_2, x_3\right)$ $u_3\left(\frac{3a}{2}, x_2 - a, x_3\right) = u_3\left(-\frac{3a}{2}, -x_2, x_3\right) + 3a\left\langle\frac{\partial u_3}{\partial x_1}\right\rangle - a\left\langle\frac{\partial u_3}{\partial x_2}\right\rangle$
	$u_1\left(\frac{3a}{2}, x_2 - a, x_3\right) = -u_1\left(\frac{3a}{2}, -x_2, x_3\right) + 3a\left\langle\frac{\partial u_1}{\partial x_1}\right\rangle - a\left\langle\frac{\partial u_1}{\partial x_2}\right\rangle$ $u_2\left(\frac{3a}{2}, x_2 - a, x_3\right) = -u_2\left(\frac{3a}{2}, -x_2, x_3\right) + 3a\left\langle\frac{\partial u_2}{\partial x_1}\right\rangle - a\left\langle\frac{\partial u_2}{\partial x_2}\right\rangle$ $u_3\left(\frac{3a}{2}, x_2 - a, x_3\right) = u_3\left(\frac{3a}{2}, -x_2, x_3\right)$	$u_1\left(\frac{3a}{2}, x_2 - a, x_3\right) = u_1\left(\frac{3a}{2}, -x_2, x_3\right)$ $u_2\left(\frac{3a}{2}, x_2 - a, x_3\right) = u_2\left(\frac{3a}{2}, -x_2, x_3\right)$ $u_3\left(\frac{3a}{2}, x_2 - a, x_3\right) = -u_3\left(\frac{3a}{2}, -x_2, x_3\right) + 3a\left\langle\frac{\partial u_3}{\partial x_1}\right\rangle - a\left\langle\frac{\partial u_3}{\partial x_2}\right\rangle$
	$-u_1(x_2, -x_2 - 2a, x_3) = u_1(-x_2 - 2a, x_2, x_3) + 2a\left\langle\frac{\partial u_1}{\partial x_1}\right\rangle + 2a\left\langle\frac{\partial u_1}{\partial x_2}\right\rangle$ $-u_2(x_2, -x_2 - 2a, x_3) = u_2(-x_2 - 2a, x_2, x_3) + 2a\left\langle\frac{\partial u_2}{\partial x_1}\right\rangle + 2a\left\langle\frac{\partial u_2}{\partial x_2}\right\rangle$ $u_3(x_2, -x_2 - 2a, x_3) = u_3(-x_2 - 2a, x_2, x_3)$	$u_1(x_2, -x_2 - 2a, x_3) = u_1(-x_2 - 2a, x_2, x_3)$ $u_2(x_2, -x_2 - 2a, x_3) = u_2(-x_2 - 2a, x_2, x_3)$ $-u_3(x_2, -x_2 - 2a, x_3) = u_3(-x_2 - 2a, x_2, x_3) + 2a\left\langle\frac{\partial u_3}{\partial x_1}\right\rangle + 2a\left\langle\frac{\partial u_3}{\partial x_2}\right\rangle$

	$-u_1 \left( -x_1 + a, -\frac{3a}{2}, x_3 \right) = u_1 \left( x_1, -\frac{3a}{2}, x_3 \right) - a \left\langle \frac{\partial u_1}{\partial x_1} \right\rangle + 3a \left\langle \frac{\partial u_1}{\partial x_2} \right\rangle$ $-u_2 \left( -x_1 + a, -\frac{3a}{2}, x_3 \right) = u_2 \left( x_1, -\frac{3a}{2}, x_3 \right) - a \left\langle \frac{\partial u_2}{\partial x_1} \right\rangle + 3a \left\langle \frac{\partial u_2}{\partial x_2} \right\rangle$ $u_3 \left( -x_1 + a, -\frac{3a}{2}, x_3 \right) = u_3 \left( x_1, -\frac{3a}{2}, x_3 \right)$	$u_1 \left( -x_1 + a, -\frac{3a}{2}, x_3 \right) = u_1 \left( x_1, -\frac{3a}{2}, x_3 \right)$ $u_2 \left( -x_1 + a, -\frac{3a}{2}, x_3 \right) = u_2 \left( x_1, -\frac{3a}{2}, x_3 \right)$ $-u_3 \left( -x_1 + a, -\frac{3a}{2}, x_3 \right) = u_3 \left( x_1, -\frac{3a}{2}, x_3 \right) - a \left\langle \frac{\partial u_3}{\partial x_1} \right\rangle + 3a \left\langle \frac{\partial u_3}{\partial x_2} \right\rangle$
	$u_1(x_1, 0, x_3) = -u_1(-x_1, 0, x_3)$ $u_2(x_1, 0, x_3) = -u_2(-x_1, 0, x_3)$ $u_3(x_1, 0, x_3) = u_3(-x_1, 0, x_3)$	$u_1(x_1, 0, x_3) = u_1(-x_1, 0, x_3)$ $u_2(x_1, 0, x_3) = u_2(-x_1, 0, x_3)$ $u_3(x_1, 0, x_3) = -u_3(-x_1, 0, x_3)$
	<p><b>Simple Stacking</b></p> $u_1 \left( x_1, x_2, \frac{l}{2} \right) = u_1 \left( x_1, x_2, -\frac{l}{2} \right)$ $u_2 \left( x_1, x_2, \frac{l}{2} \right) = u_2 \left( x_1, x_2, -\frac{l}{2} \right)$ $u_3 \left( x_1, x_2, \frac{l}{2} \right) = u_3 \left( x_1, x_2, -\frac{l}{2} \right) + l \left\langle \frac{\partial u_3}{\partial x_3} \right\rangle$ <p><b>Symmetric Stacking</b></p> $f_1 \left( x_1, x_2, \pm \frac{l}{2} \right) = 0$ $f_2 \left( x_1, x_2, \pm \frac{l}{2} \right) = 0$ $u_3 \left( x_1, x_2, \pm \frac{l}{2} \right) = \pm \frac{l}{2} \left\langle \frac{\partial u_3}{\partial x_3} \right\rangle$	<p><b>Simple Stacking</b></p> $u_1 \left( x_1, x_2, \frac{l}{2} \right) = u_1 \left( x_1, x_2, -\frac{l}{2} \right) + l \left\langle \frac{\partial u_1}{\partial x_3} \right\rangle$ $u_2 \left( x_1, x_2, \frac{l}{2} \right) = u_2 \left( x_1, x_2, -\frac{l}{2} \right) + l \left\langle \frac{\partial u_2}{\partial x_3} \right\rangle$ $u_3 \left( x_1, x_2, \frac{l}{2} \right) = u_3 \left( x_1, x_2, -\frac{l}{2} \right)$ <p><b>Symmetric Stacking</b></p> $u_1 \left( x_1, x_2, \pm \frac{l}{2} \right) = \pm \frac{l}{2} \left\langle \frac{\partial u_1}{\partial x_3} \right\rangle$ $u_2 \left( x_1, x_2, \pm \frac{l}{2} \right) = \pm \frac{l}{2} \left\langle \frac{\partial u_2}{\partial x_3} \right\rangle$ $f_3 \left( x_1, x_2, \pm \frac{l}{2} \right) = 0$

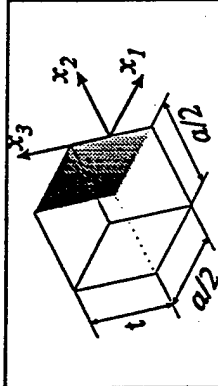
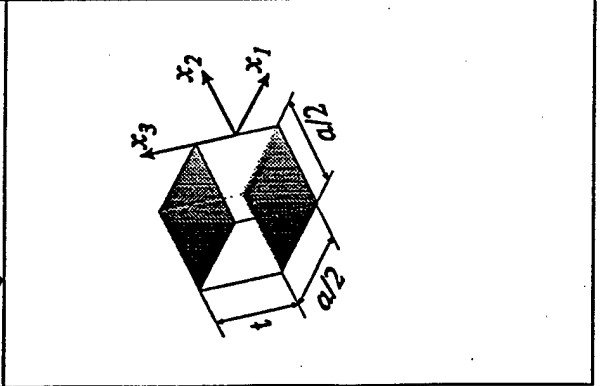
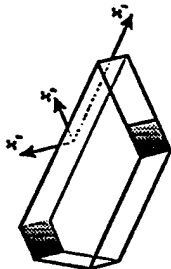
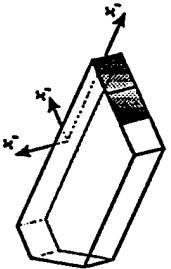
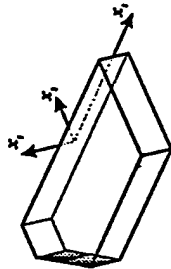
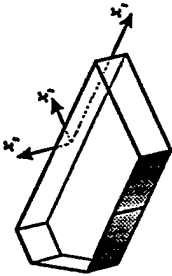
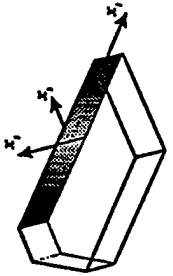
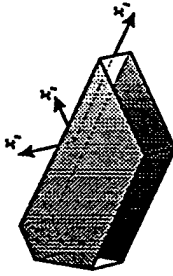
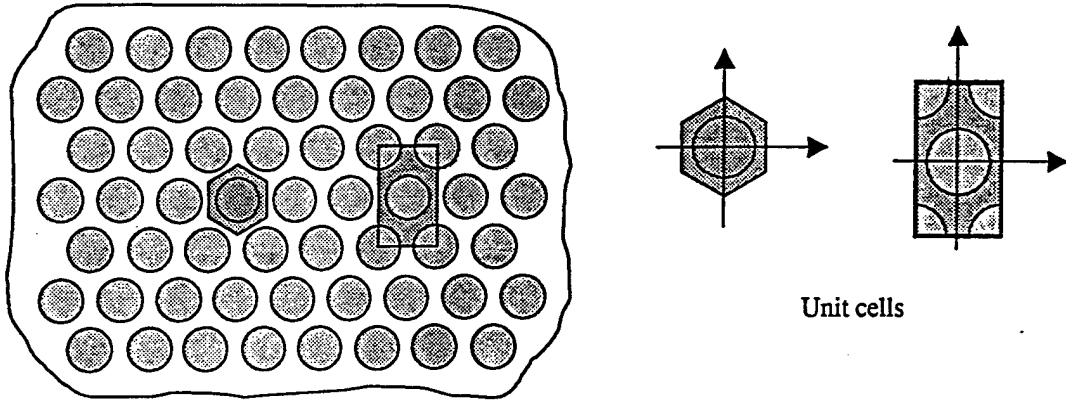

Unit cells

(a) Hexagonal array of fibers in matrix

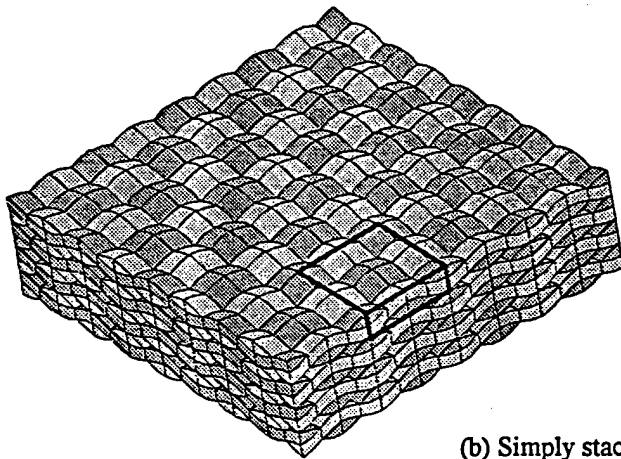

(b) Simply stacked plain weave

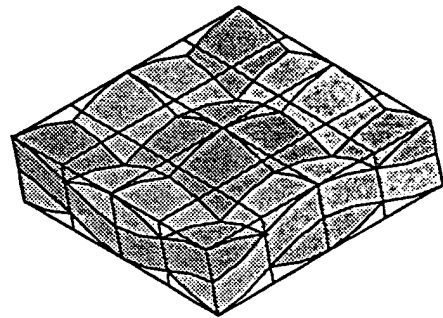

Unit cell

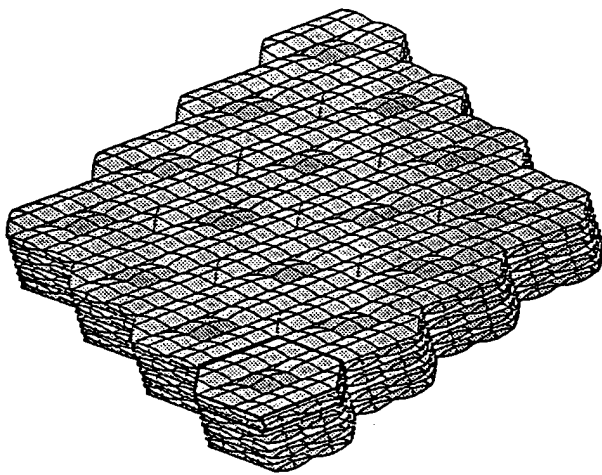

(b) Simply stacked satin weave

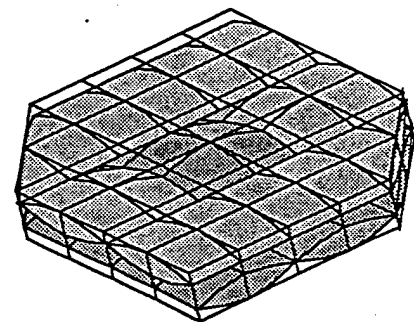

Unit cell

Figure 1. Examples of periodic microstructure

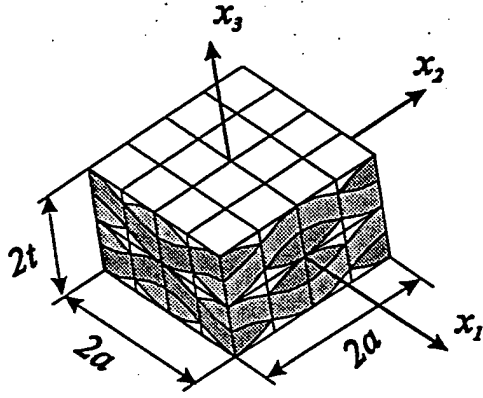

(a) Full unit cell

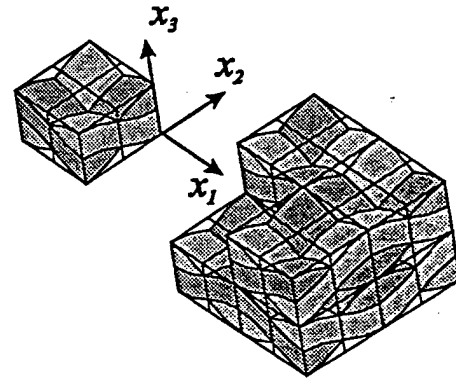

(b) 1/8 unit cell considered (shown cut from full unit cell)

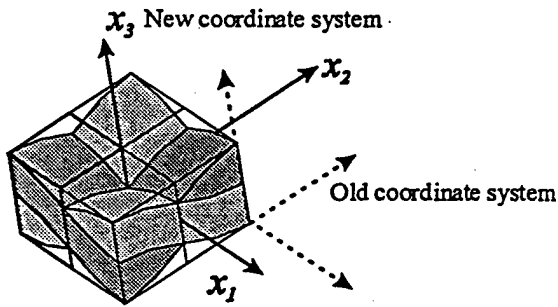

(c) New coordinate system

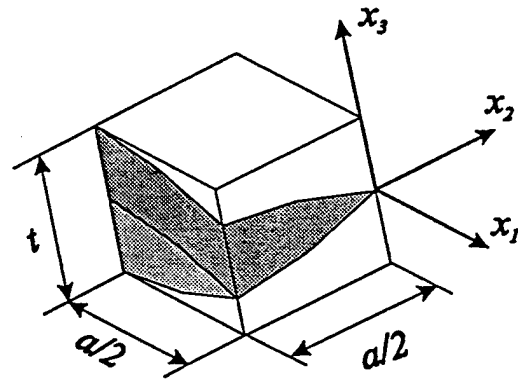

(d) 1/32 unit cell

Figure 2 Coordinate systems and regions used in derivation of boundary conditions for symmetrically stacked plain weave

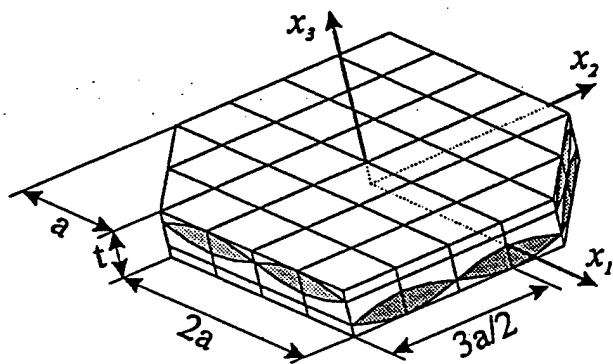

(a) Full unit cell

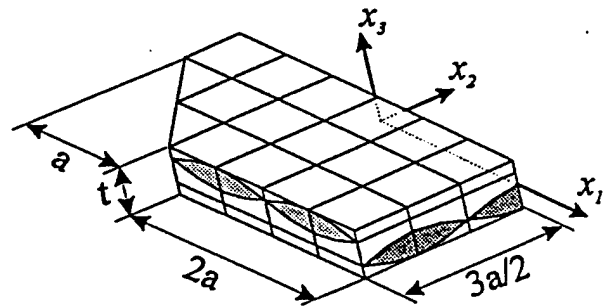

(b)  $\frac{1}{2}$  unit cell considered

Figure 3 Coordinate system and regions used in derivation of boundary conditions for simply stacked 8-harness satin weave

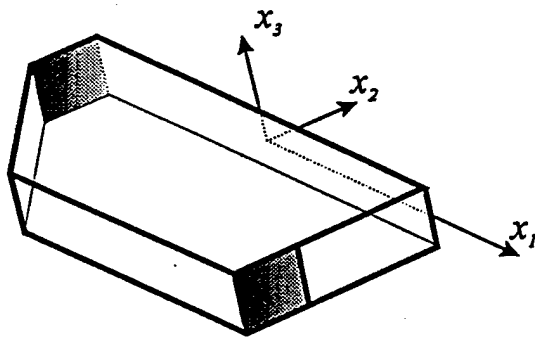

(a) Regions where boundary conditions are based on periodic conditions.

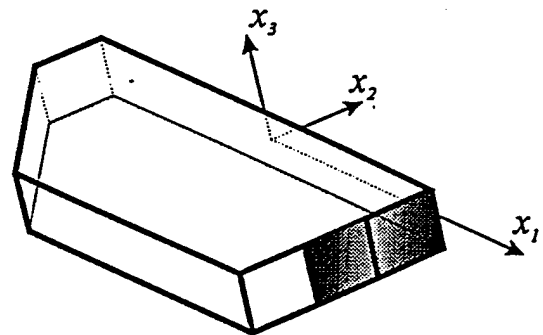

(b) Region where boundary conditions are based on both periodic and equivalent coordinate system constraints.

Figure 4 Paired regions for multipoint constraints.