

5995

RR

REPROD
COPY

TECHNICAL

OTS: 60-11,691

JPRS: 5945

25 October 1960

LOGICAL DESIGNS OF COMPUTERS WITH
SEMICONDUCTOR COMPONENTS

By V. A. Zimin

- USSR -

RETURN TO MAIN FILE

DISTRIBUTION STATEMENT A
Approved for Public Release
Distribution Unlimited

Reproduced From
Best Available Copy

20000724 121

DTIC QUALITY INSPECTED 4

Distributed by:

OFFICE OF TECHNICAL SERVICES
U. S. DEPARTMENT OF COMMERCE
WASHINGTON 25, D. C.

Price: ~~\$1.00~~

U. S. JOINT PUBLICATIONS RESEARCH SERVICE
1636 CONNECTICUT AVE., N. W.
WASHINGTON 25, D. C.

F O R E W O R D

This publication was prepared under contract by the UNITED STATES JOINT PUBLICATIONS RESEARCH SERVICE, a federal government organization established to service the translation and research needs of the various government departments.

JPRS:5945

CSO : 4688-N/e

LOGICAL DESIGNS OF COMPUTERS WITH
SEMICONDUCTOR COMPONENTS.

Following is the translation of an article by V. A. Zimin entitled Logicheskiye Skhemy Vychislitel'nykh Mashin s Poluprovodnikovymi Priborami (English version above) in Avtomaticheskoye Upravleniye i Vychislitel'naya Tekhnika (Automatic Control and Computer Technique), pages 204-222, Moscow, 1958.

The contemporary state of the automatic control theory allows a mathematical formulation of all problems of complex automation of practical importance and the modern methods of computer technique make it possible to solve these problems. However, the problems encountered in practice are usually very complex and in order to solve them precisely it is necessary to carry out a large number of computations. For example, in the automatic control of metal-machining lathes it is necessary to convert the design data into the initial data for the controlling servomechanisms of the lathe. The high-speed computers which operate automatically in accordance with a pre-set program, can solve very complex equations in a short time. In addition to numerical calculations, a computer can also perform logical opera-

tions and store the results of the operations performed previously.

Computers suitable for use in automatic control systems must be characterized by high speed and high accuracy of the computations, by an adequate flexibility of program control, by reliable performance, simplicity and economy of operation and finally, such machines must be transportable and easy to manufacture.

These requirements can be satisfied most completely when electron networks constructed of semiconductor devices are used in the counting and control circuits of a high-speed computer.

These circuits usually consist of combination circuits performing the function of the logical element OR, the coincidence circuits performing the function of the logical element AND, anti-coincidence circuits performing the function of the logical element NO, and also of the circuits having two stable states performing the functions of the arithmetic element which may be utilized as the memory cell, the counter cell or as the switch cell.

The input arithmetic element actuates directly or through an amplifying circuit the circuits of the logical elements which in their turn actuate directly or through an amplifying cascade the output arithmetic element. Therefore, an analysis of the principles of the design of different makes of computers can be reduced to the analysis of the interaction of the electron networks of which the counting and the control circuits are constructed. From the results of the analysis it is possible to form a conclusion concerning the rate of the

operation, reliability and amount of the necessary equipment, i.e. it is possible to obtain a complete idea of the technical and economic characteristics of a computer.

With respect to the types of couplings, the computer circuits may be divided into circuits with direct couplings usually called static circuits, circuits with inductive and capacitive couplings which are usually called dynamic circuits, and finally, circuits in which there may be both the pulse-type and direct linkage.

In the static circuits, the electric signals used are in the form of two voltage levels: high and low, in the dynamic circuits - in the form of an electric voltage pulse or current pulse.

The static circuits are comparatively simple to make. However, in computers built with these circuits there is used a large number of semiconductor triodes. Thus, in the electronic perforator IBM-608 [1] about 2200 triodes are used, and the arithmetic unit for 19 binary numbers in the computing device of the "TRANSAC" contains 1242 triodes [2].

Particularly high requirements are demanded of the frequency characteristics of the semiconductor triodes. Thus, for example, for the electronic perforator IBM-608 operating at the repetition rate of 50 kilocycles per second, junction triodes with the maximum frequency of not below 1000 kilocycles per second were selected, and in the computer "TRANSAC" the triggers of which can operate at the frequency of

1 megacycle per second, surface-barrier triodes designed for a maximum frequency of 100 megacycles are used.

In time the semiconductor triodes change their characteristics and therefore their useful life is limited. As demonstrated by observations, the life of germanium triodes surpasses the life of the electron tubes by only a few times.

Thus, computers with direct couplings based on the use of semiconductor triodes of the existing makes are characterized by a relatively low rate of operation, are insufficiently reliable with respect to performance and require a comparatively large amount of equipment.

Dynamic pulse-type counting and control circuits are more complex with respect to their manufacture than the static circuits. This is explained by the necessity for adhering to the phase relationships of the signals representing the number or command codes. However, the advantage of the dynamic circuits is that in the main, diodes may be used in them and the triodes can be utilized only as amplifiers. Thus, for example, in the computer "TRADIC" which operates at the frequency of 1000 kilocycles per second, 11,000 germanium diodes are used and only 800 point-contact triodes [37].

A computer consists basically of electron circuits which realize logical operations. The functions of the logical circuits consist of the transmission of electric signals in the directions determined by the control program of the machine. Therefore, the networks of logical circuit elements must have small losses. It is known that the elements

of the electronic computers are electric circuits in which the parameters can be switched [4]. Consequently, a diode may be used as the key in the logical circuits.

The semiconductor diodes should be used in combination with the oscillation circuits which have a high effective resistance for the pulse and make it possible to transmit pulses with a slight attenuation. Under certain conditions, the role of the oscillatory circuit can be performed by the pulse shaping transfer with a ferrite core [5].

As the studies have shown, the diode-transformer circuits can operate one another sufficiently efficiently and do not require intermediate amplifiers for each stage. Thus, the diode-transformer circuits help to solve successfully the basic problem of the computer technique - to create highly economical elements which have an unlimited useful life.

A particular advantage of diode-transformer circuits is that a semiconductor device operates between the transformer coils. The forward resistance of a diode is incomparably less than the effective resistance of the coil for an oscillating component of a pulse. On the other hand, the reverse resistance of a diode is considerably higher than the coil resistance for a direct component. Therefore, a change in the characteristics of a semiconductor device in time and temperature is not reflected on the parameters of a diode-transformer circuit. This explains the extremely reliable performance of the semiconductor

diodes in such circuits.

The semiconductor triodes are characterized by low power and a low value of the input resistance and therefore they have to operate on small signals. The magnitude of the signal is also limited by the requirement of high-speed operation because the smaller the signal amplitude, the less energy is absorbed by the spurious capacitances and inductances. Consequently, the smaller the magnitude of the signal the quicker the electric circuit is damped. A decrease in the signal amplitude is also favorably reflected on the decrease in the power supply.

The parameters of the existing point-contact diodes and also the technically feasible and economically efficient parameters of the transformers with ferrite cores are such that there is a possibility of operating with pulses of the amplitude of 2 to 3 volts. In comparison with the magnitude of the signals used in other known circuits this is several times less.

POTENTIALITIES OF THE LOGICAL ELEMENTS. All logical operations in a computer can be realized with the aid of three basic connectives: OR, AND, NOT. Let us cite a few examples of the construction of the counting and control circuits with these connectives.

In the adder circuit diagram with three inputs (Figure 1) the sum a is formed in the following manner:

$$a = (x + y + z) (xyz + \bar{b}), \quad (1)$$

where x, y, z are the number or common code pulses on the adder inputs.

\bar{b} - the addition of the carry pulse.

The carry occurs every time when the following relation holds:

$$b = xy + yz + xz. \quad (2)$$

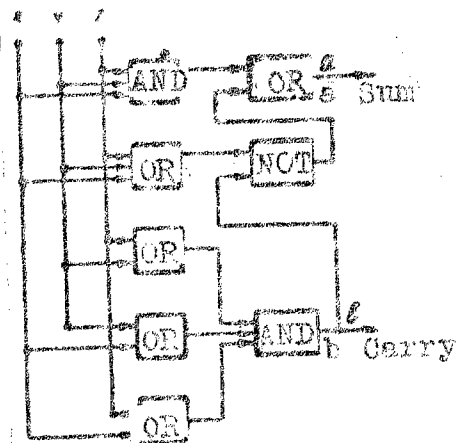

Figure 1. The basic diagram of an adder based on the logical elements OR, AND and NOT with the predominant use of the logical elements OR.

- (1) - AND
- (2) - OR
- (3) - NOT
- (4) - a Sum
- (5) - b Carry

The input pulses arrive at the circuit AND having three inputs, at the circuit OR having three inputs and at three circuits OR with two inputs each.

The circuit AND sends a pulse to the sum output only if there are pulses on all three inputs. The transmission of the pulses is accomplished through the circuit OR with two inputs. The circuit OR with three inputs transmits the pulses to the circuit NOT. If there is a pulse only on one of the inputs of the adder, the circuit NOT does not inhibit and the pulse passes to the sum output. If however, there are pulses on two or all three inputs, then the carry pulse appears which inhibits the passage of the pulses through the circuit NOT. The carry pulses are sent to the output through the circuits AND having three inputs when there are pulses on two or all three inputs of the adder. The distribution of the pulses appearing on two inputs of the adder to the three inputs of the circuit is accomplished by the three circuits OR designed for two inputs each.

An adder can be constructed with the preponderance of those circuits which have the highest technical characteristics. The adder shown in Figure 1 consists chiefly of the circuits OR and thereby it differs from the other known systems where circuits AND are predominantly used.

Logical systems can also be successfully used for the control circuits. Let us consider one of the possible circuits of control by means of the shift register (Figure 2).

If in the accumulation cell H with a delay line unity is set up for the repetition period of the synchronizing pulses, then this cell

remains in the energized state with the aid of the synchronizing pulses. These pulses pass through the circuit NOT and arrive at one of the inputs of the middle circuit AND the second input of which is connected with the output of the memory cell. At the instant of the

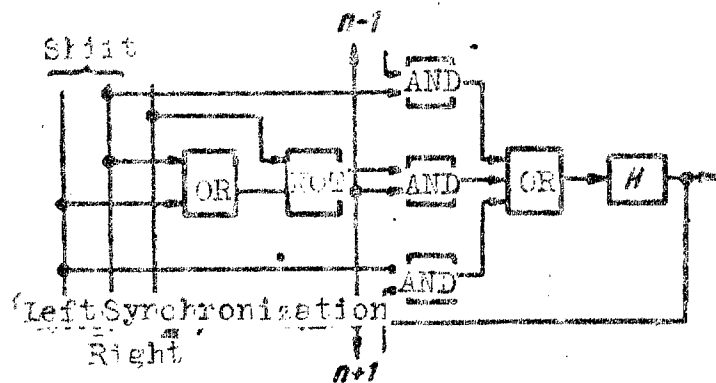

Figure 2. The basic circuit diagram of control by means of a shift register with the aid of the logical elements OR, AND and NOT.

- (1) - Shift
- (2) - OR
- (3) - NOT
- (4) - AND
- (5) - Left
- (6) - Right
- (7) - Synchronization
- (8) - H Memory cell

shift, the shifting pulse passes through the circuit OR and inhibits the passage of the synchronizing pulses through the circuit NOT. At the same time, zero instead of unity is set up in the accumulation

cell if it was energized and if the cell was not energized then it remains in the same state. Depending on the direction in which the shift takes place - right or left, the shifting pulse arrives at the input of the upper or lower circuit AND.

The reception of the code is accomplished by the accumulation cell from the $(n - 1)$ cell or $(n + 1)$ cell. And the code from the n -th accumulation cell is transmitted to the $(n + 1)$ or $(n - 1)$ cells respectively. After the termination of the shifting pulse, the inhibit is removed from the circuit NOT and the synchronizing pulses maintain the new state of the accumulation cell. The circuit OR with three inputs plays an auxiliary role and serves as the separation stage.

The basic circuit diagram of a computer may be constructed in such a manner that the accumulation cells will be the initial and terminal links of the counting and controlling circuits. In the case when logical elements with small losses are used, the accumulation cells may be given the functions of the input and output amplifiers. Let us show this by the example of an adder.

In the adder shown in Figure 3, transformers with ferrite cores Okeifer 400 (Ferrocart 400) and semiconductor diodes DG-Ts2 and DG-Ts8 are used. These transformers have the same number of turns in the primary and secondary coils. An oscillogram of the electric characteristics of a diode-transformer adder confirms that the accumulation cells with semiconductor triodes can handle the most complex logical circuits of computers. The effect of the adder on the input circuits

is insignificant, the transmission coefficient is satisfactory and the signal-to-interference ratio on the output of the adder is sufficiently high.

The study of the electric circuit of the adder and of the oscillograms of the signals on its inputs and outputs shows that the diode-transformer circuits make it possible to realize the logical elements OR, AND and NOT with the transmission coefficient of about

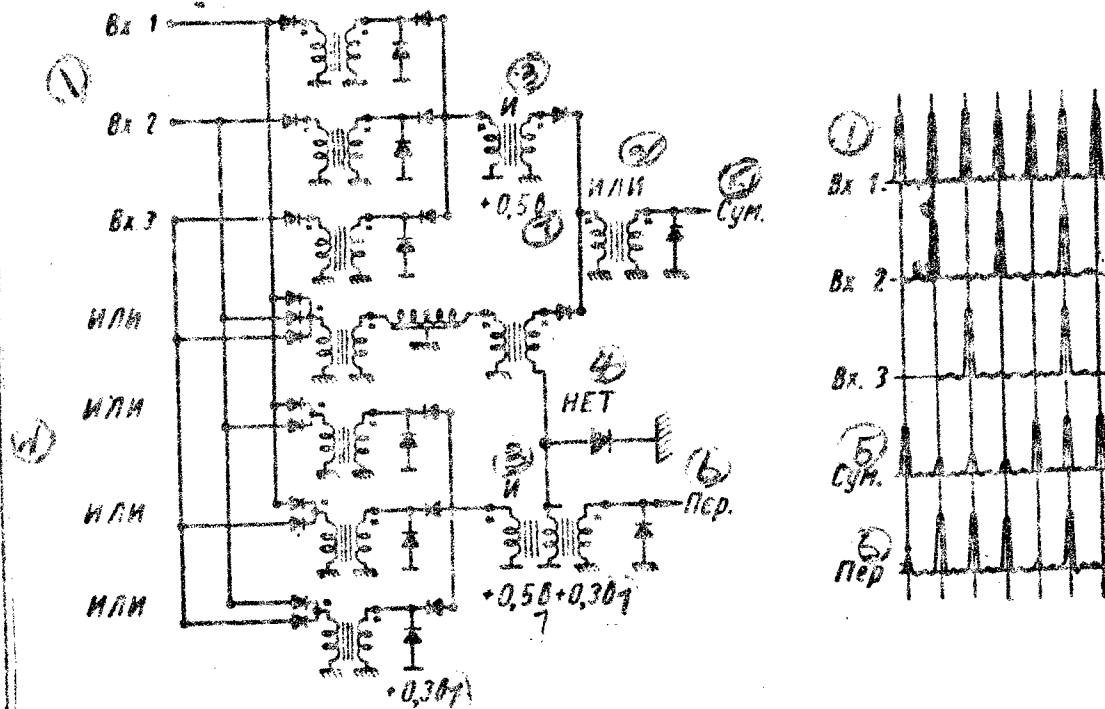

Figure 3. Electric circuit diagram of a diode-transformer adder and oscillograms of the pulses on its inputs and outputs.

- | | |
|-------------|-------------|
| (1) - Input | (5) - Sum |
| (2) - OR | (6) - Carry |
| (3) - AND | (7) - volts |
| (4) - NOT | |

As the theoretical and experimental investigations have shown, the optimum value of the controlling pulse amplitude comprises $2 \div 5$ volts. Pulses of smaller amplitude are transmitted with a larger loss than the pulses of optimum amplitude. This makes it possible to reduce the interference in a diode-transformer circuit to the minimum and to secure a sufficiently high quality of the transmission of the useful signals. It was also found that the pulse power expended for the control of one logical element does not exceed one milliwatt. Thus, the existing high-frequency germanium triodes may be used as an amplifier-transformer even in a parallel computer. Naturally, the semiconductor triodes should be used in a circuit with matching transformers which secures a high value of the input resistance and a low value of the output resistance.

LOGICAL ELEMENT "OR". Logical elements OR may be widely used in the construction of the counting and controlling circuits intended for different purposes. They are more efficient than the rest of the logical elements. For example, when using these elements the process of the passage of the pulses is not accompanied by the appearance of interference as in the circuits AND and NOT. The electronic circuit performing the logical operation OR is essentially a combination circuit with n -inputs (Figure 4). A pulse appears on the output of this circuit every time when there is a pulse on one of its inputs. The interaction of the input signals is eliminated since diodes are

serially connected with all inputs. There are known two types of the circuits of the logical elements OR with semiconductor devices: diode-resistor-type circuits [6] and diode-transformer-type circuits [5]. Let us consider their advantages and shortcomings.

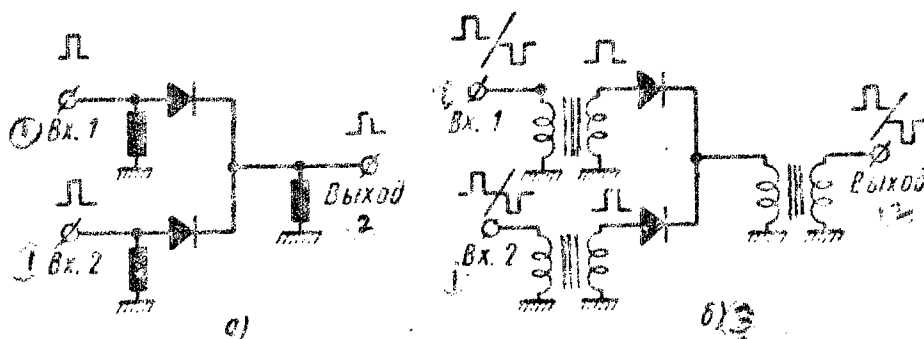

Figure 4. Electric circuit of the logical element OR:

a - diode-resistor-type circuit; b - diode-transformer-type circuit.

- (1) - Input
- (2) - Output
- (3) - b

An equivalent circuit of the diode-resistor-type element OR will appear as shown in Figure 5 a (R_i denotes the internal resistance of the diode). The intermediate transmission function for such an electric circuit may be written in the following manner:

$$U_{out} = U_{in} \frac{R}{R + R_i} \left(1 - e^{-\frac{t}{R_0 C}} \right), \quad (3)$$

$$R_0 = \frac{R \cdot R_i}{R + R_i}.$$

where

1

In order that the reactive component (the factor in the parenthesis) not reduce in a substantial manner the voltage on the output,

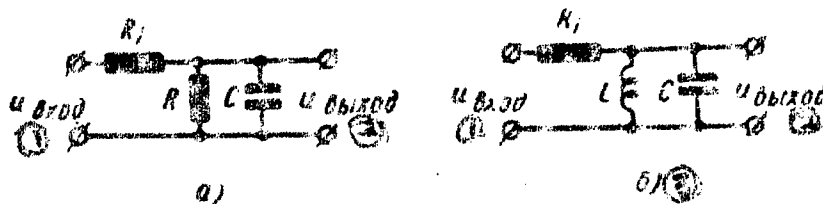

Figure 5. Equivalent circuits of the logical element OR for the case of $R_{in} \approx R_{out}$:

a - diode-resistor-type circuit; b - diode-transformer-type circuit.

- (1) - u input
- (2) - u output
- (3) - b

it is necessary that the ratio $\frac{t}{R_0 C}$ be sufficiently large for the instant corresponding to the maximum value of the pulse amplitude. If the influence of the spurious capacitance is limited to 1%, then it is necessary that the relation $t \approx 5R_0 C$ be valid.

The pulse rise time τ_p may not be arbitrary and is determined

by the shape of the pulses. Pulse duration τ_n is determined by the minimum pulse repetition time t_n :

$$\tau_n \ll 0.5 t_n \text{ minutes.}$$

Assuming that the operation is performed by triangular pulses, we will obtain

$$R_0 C \ll 0.05 t_n \text{ minutes}$$

Thus, for the repetition rate of 1000 kilocycles per second, the time constant must not exceed 0.05 microseconds. When this condition is not observed, the effect of spurious capacitance appreciably increases. Therefore, if the pulse duration amounts to parts of a microsecond, the resistance R in the diode-resistor-type circuit OR must amount to thousands of ohms.

Let us analyze now the effect of the internal resistance of a semiconductor diode on the transmission coefficient of the diode-resistor-type circuit OR. If we want to obtain a transmission coefficient approaching unity, i.e. if we want to assure the observance of the relation $U_{out} \approx U_{in}$, then in accordance with (3) it is necessary that $R_1 \ll R$. In practice, if $R_1 \approx 0.01$ of R which corresponds to a small magnitude of the anode voltage drop, then the transmission coefficient will be very close to unity.

The graph represented in Figure 6 shows that when the anode voltage of the diode is ≈ 1 volt, the internal resistance of the diode

fluctuates from 100 to 1000 ohms depending on the type of diode.

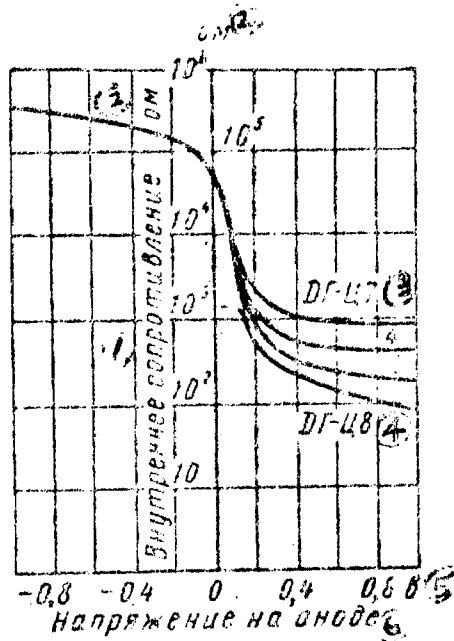

Figure 6. Internal resistance of point-contact germanium diodes DG-Ts.

- (1) - Internal resistance
- (2) - Ohms
- (3) - DG-Ts7
- (4) - DG-Ts8
- (5) - Volts
- (6) - Anode voltage

Upon the drop of the anode voltage to ± 0.1 volts, the internal resistance increases to 10,000 ohms and does not depend on the type of the diode. After substituting in the expression (3) the value of the internal resistance of the diode obtained from the graph, it is not hard to note that the diode-resistor circuit OR is characterized by a low value of the transmission coefficient, especially when operating

with small signals.

Thus, the circuits of the logical elements OR examined above, cannot operate without amplifiers. The bias resulting from the passage of the rectified current through the resistance R also lowers the transmission coefficient. Therefore, in the counting and controlling circuits constructed with diode-resistor-type logical elements, it is necessary to restrict the use of the circuits OR and replace them as far as possible with more complex circuits AND.

Let us consider the operation of a diode-transformer-type circuit of the logical element OR under no-load conditions. In addition, let us assume that the transformer has small losses. These assumptions make it possible to disregard the effect of the secondary coil of the transformer on the parameters of the primary coil and consequently to replace the transformer with a parallel circuit without losses, the L in this circuit expressing the self-inductance of the primary coil and C - the coil capacitance with the spurious capacitance taken into account. As is known, the form of the transition function of transmission depends in the case of a parallel circuit on the ratio of the circuit and diode parameters. Under the condition that $R_1 < \frac{1}{2} \sqrt{\frac{L}{C}}$, the process is aperiodic and for the transformation ratio equal to unity, we have:

$$U_{\text{out}} = U_{\text{in}} \left(1 - 4R_1^2 \frac{C}{L} \right)^{-\frac{1}{2}} (e^{-at} - e^{-bt}), \quad (4)$$

where

$$a = \frac{1}{2R_1 C} - \sqrt{\frac{1}{4R_1^2 C^2} - \frac{1}{LC}}$$

$$b = \frac{1}{2R_1 C} + \sqrt{\frac{1}{4R_1^2 C^2} - \frac{1}{LC}}$$

If however, $R_1 > \frac{1}{2} \sqrt{\frac{L}{C}}$, then the process becomes oscillatory

and attenuating:

$$U_{\text{out}} = U_{\text{in}} \cdot 2 \left(4R_1^2 \frac{C}{L} - 1 \right)^{-\frac{1}{2}} e^{-\frac{t}{2R_1 C}} \sin \omega t, \quad (5)$$

where

$$\omega = \sqrt{\frac{1}{LC} - \frac{1}{4R_1^2 C^2}}$$

Expressions (4) and (5) indicate that with a definite ratio of the circuit and diode parameters, the output voltage of the circuit being considered may exceed the input voltage at some instant of time.

After comparing these expressions with the expression (3), we ascertain that the diode-transformer-type circuits can transmit the pulses better than the diode-resistor-type circuits.

The application of ferrite cores makes it possible to create transformers possessing resistance which secures transmission coefficient approaching unity for the diode-transformer-type circuits OR.

An example of the serially connected circuits OR assembled of coupled circuits and semiconductor components is shown in Figure 7. Used as coupled circuits are toroidal transformers with ferrite cores Oksifer 400 (Ferrocart 400). The number of turns in both coils is the same and consequently the transformation ratio amounts to unity. Used as the semiconductor components are the point-contact germanium diodes DG-Ts2. In the left portion of the Figure is shown a circuit in which the diodes operate to increase the current in the middle circuit - the circuit where the diodes operate for the reduction of the current. Shown in the right portion of the diagram is a chain of transformers without intermediate diodes. Each electric circuit was assembled from identical transformers and diodes.

After comparing the oscillograms of the circuits with diodes and the circuit without diodes (the latter can be likened to a long line), no appreciable difference can be discovered in the character of the passage of the pulses.

Thus, the results of the experiment confirm the feasibility of creating sufficiently extensive logical circuits OR with diodes and transformers and having a transmission ratio approaching unity. A study of the role of the voltage of the direct current supply showed that the feed current serves for the bias of the operating point of the diodes and performs the loading functions for the transformers. Therefore, when selecting the mode of the power supply it should be taken into consideration that it depends to some degree on the repeti-

tion rate and the shape of the pulses.

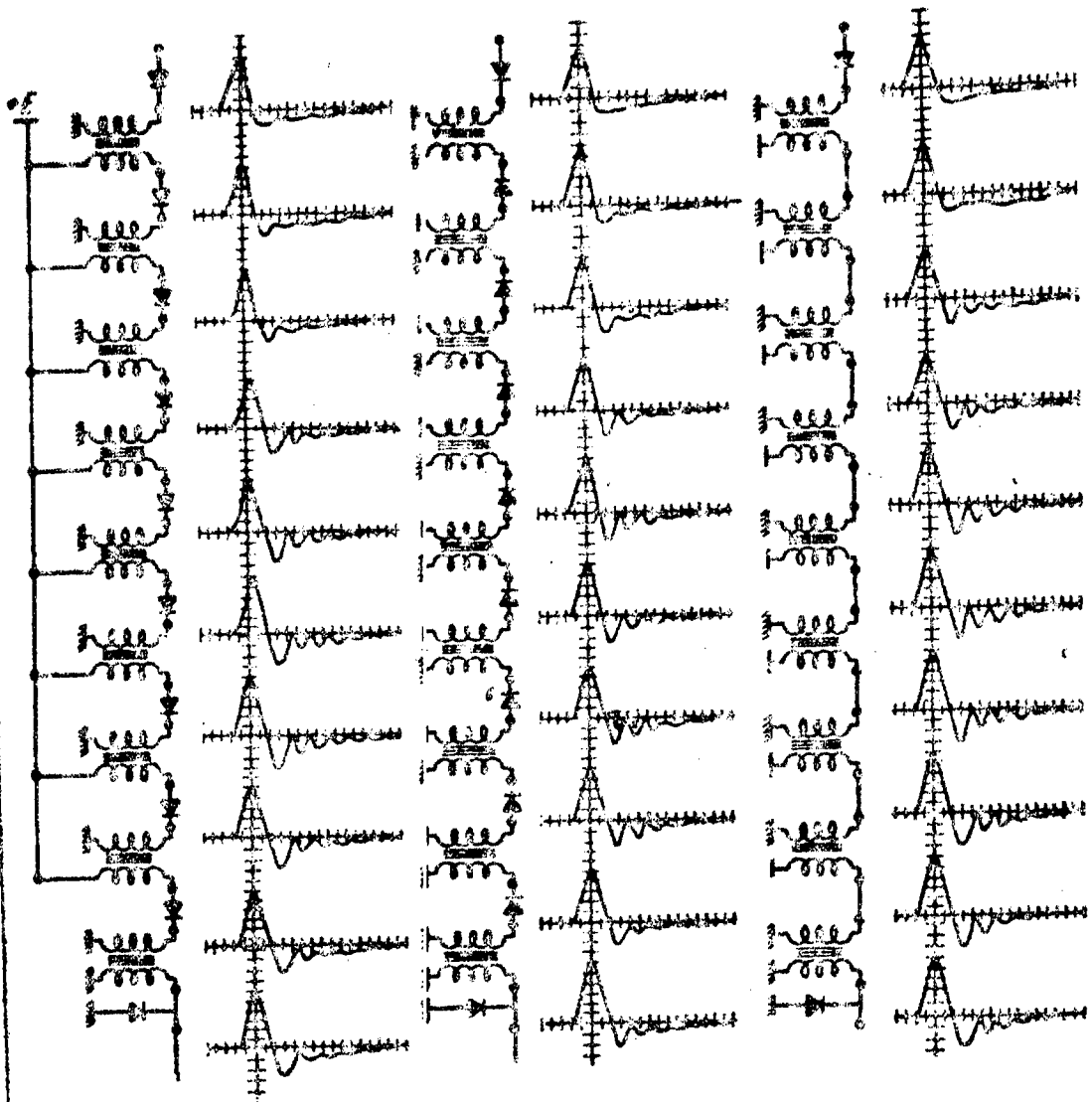

Figure 7. The passage of pulses along an electric circuit composed of the diode-transformer-type logical elements OR.

LOGICAL ELEMENT "AND". In the existing computers, the most widely used logical element is AND. As is known, the operation AND is performed by the electric coincidence circuit (Figure 8). The sig-

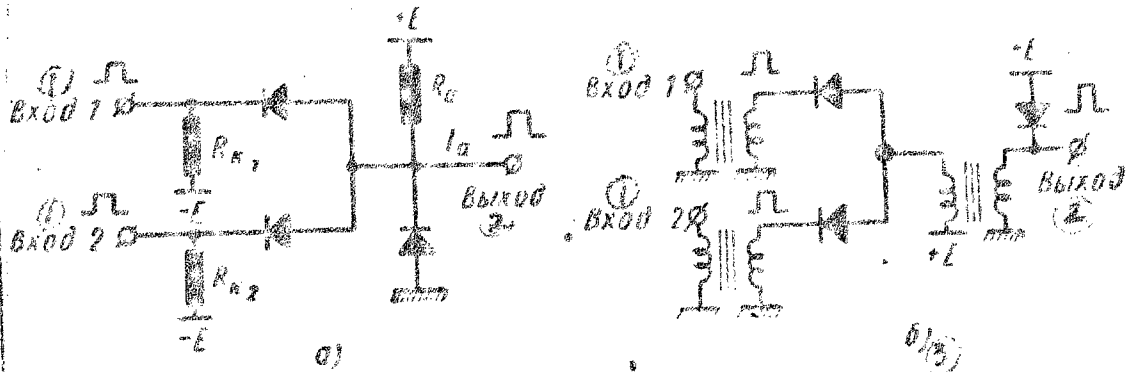

Figure 8. Electric circuits of the logical element AND.

a - diode-resistor-type circuit; b - diode-transformer-type circuit.

- (1) - Input
- (2) - Output
- (3) - b

nal on the output of such a circuit appears only if there are signals on all of its inputs. If however, the signals do not arrive at all of the circuit inputs, then interference develops on the output.

There exist two types of circuits AND with semiconductor devices: diode-resistor-type circuits [6] and diode-transformer-type circuits [5].

The study of the circuit AND with germanium diodes and resistors shows that it is not sufficiently economical. In addition, such circuits cannot operate one another with a sufficiently high transmission ratio. This is explained by the circumstance that the input resistance must be considerably lower than the output resistance and the output resistance which would be sufficiently high with respect to the absolute magnitude cannot be selected.

The magnitude of the output resistance R_a is limited by the time constant τ of the output circuit, this constant having to correspond to the inequality $\tau \ll 1/3 \tau_{ul}$ during normal operation. From this, the value of the resistance is defined by the inequality:

$$R_a \leq \frac{\tau_{ul}}{3C}, \quad (6)$$

where C is the capacitance of the output circuit;

τ_{ul} - the duration of the operating pulse.

The minimum value of the output capacitance is equal to the magnitude of the spurious capacitance. Therefore, similarly to the circuit OR, the resistance R_k must amount to thousands of ohms if the duration of the pulses amounts to fractions of a microsecond. In this case, the input resistance R_k cannot be selected arbitrarily. In order that the interference on the output of the circuit be smaller than the signal, it is necessary to comply with the inequality $R_k \ll R_a$.

The maximum interference voltage U_{int} will be in the case when the signals are absent on only one of the inputs of the circuit. In this case, in the absence of a damping diode D, the current passing through the only open diode increases by the magnitude

$$\Delta I = \frac{I_a}{n} (n - 1), \quad (7)$$

where I_a is the current passing through the resistance R_a ;
 n - the number of the circuit inputs.

In addition to this, the interference voltage will be equal to:

$$U_{int} = U_{out} \Delta I (R_i + R_K), \quad (8)$$

where R_i is the diode resistance at the operating point.

Let us assume that in the case of the simultaneous arrival of the signals at all inputs, the signal voltage on the output of the circuit is equal to $U_{int} = I_a \cdot R_a$. Then for the maximum value of the interference we will obtain

$$U_{int}^{max} = U_{output}^{max} \frac{(n - 1)}{n} \cdot \frac{(R_i + R_K)}{R_a}. \quad (9)$$

After examining a simplified circuit, we assume that the role of the damping diode D consists of a supplementary reduction in the value of the input resistance of the circuit at the instants of anti-

coincidence. Thus, the interference is the smaller, the lower the input resistance of the circuit compared to the output resistance. Consequently, these circuits cannot operate for one another without considerable damping.

In the diode-transformer-type circuit shown in Figure 8 b, the transformer may be regarded as a parallel circuit the magnitudes of the inductance, resistance and capacitance of which are determined by the inherent parameters of the transformer. The advantage of the transformer is that the diode-transformer circuits AND can operate sufficiently efficiently for one another.

For the purpose of determining the advantages and shortcomings of the diode-transformer-type circuits AND, three basic circuits denoted conditionally by symbols A, B and C were investigated. In the circuit A, the logical operation is accomplished with the aid of diodes which operate as keys while the transformer is used only as an output circuit. In the circuit B, the logical operation AND is performed by the transformers and the diodes play an auxiliary part by performing the functions of separation circuits. In the circuit C, both the diodes and the transformers take part in the logical operation.

The basic parameter of the logical circuits AND is the ratio of the signal to interference. In the final analysis, the operational stability of the logical circuits depends on this ratio. There exist two basic methods for improving the signal-to-interference

ratio: limiting the interference and suppression of the interference.

In the former case the limiting voltage is connected to the limiting diode in series with the signal voltage, the phases of both voltages having to be shifted by 180° and the magnitude of the limiting voltage having to correspond to the interference amplitude. This constitutes the principal drawback of this method.

The second method provides for the parallel connection of the signal output and the resistance of the damping diode, the magnitude of the resistance being low for weak signals and high for the large signals. It is assumed that the interference is weaker with respect to power than the signals. For the circuits AND operating on the principle of the signal coincidence this condition always corresponds to the actual conditions since the outputs are added at the instant of the coincidence.

The essence of the interference suppression method consists of the following. The anode voltage of the diode U_a is laid off on the operating characteristic of the damping diode (Figure 9) along the X-axis, and along the Y-axis - the internal resistance of the diode R_i . Shown below, is the pulse acting on the cathode of the diode U_n . The damping diode uses up the pulse power until the pulse voltage U_n increases to the magnitude at which the internal resistance of the diode R_i heads in the direction of an infinitely large magnitude. Meant by the infinity in this case is the tenfold excess of the input resistance of the circuit for which the circuit with the damping diode

operates. The power used by the damping diode is proportional to the time t_0 during which the magnitude of the internal resistance of the

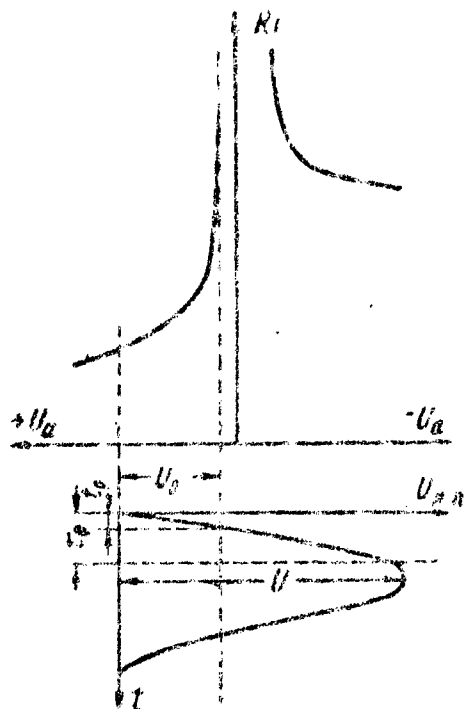

Figure 9. Graph for the calculation of the power absorbed by the damping diode.

diode changes from a finite value to infinity. This time may be expressed in terms of the parameters of the operating conditions of the diode and in terms of the pulse parameters:

(10)

where τ_f is the duration of the forward pulse front.

Thus, the larger the pulse amplitude, the smaller the power absorbed by the damping diode. Consequently, a damping diode represents a large load for small pulses and a small load for large pulses. This is explained by the circumstance that in the case of a small pulse, the time during which the internal resistance of the diode has a small magnitude, is longer than in the case of a pulse of the same shape but larger amplitude. In a number of cases the useful signal and interference are equal with respect to amplitude but the internal resistance of the equivalent interference generator is greater than that of the signal. This is valid for coincidence circuits. At the same time, the damping diode sharply reduces the interference amplitude since the ratio of the internal resistance of the diode to the sum of the resistances of the equivalent generator and diode will be considerably smaller for the interference than for the signal. As the result, the problem is reduced to the case of small amplitude and consequently to a continuous connection of the load to the source of the interference.

The electric circuit used for the study of the logical element AND constructed according to the circuit diagram A (Figure 10) may be identified with the logical circuit OR-AND-OR. Placed on the output of the circuit for the load is diode D. Used as the coupled circuits are toroidal transformers with ferrite cores Oksifer 400 (Ferrocart 400) and having an equal number of turns in the primary and secondary

cells.

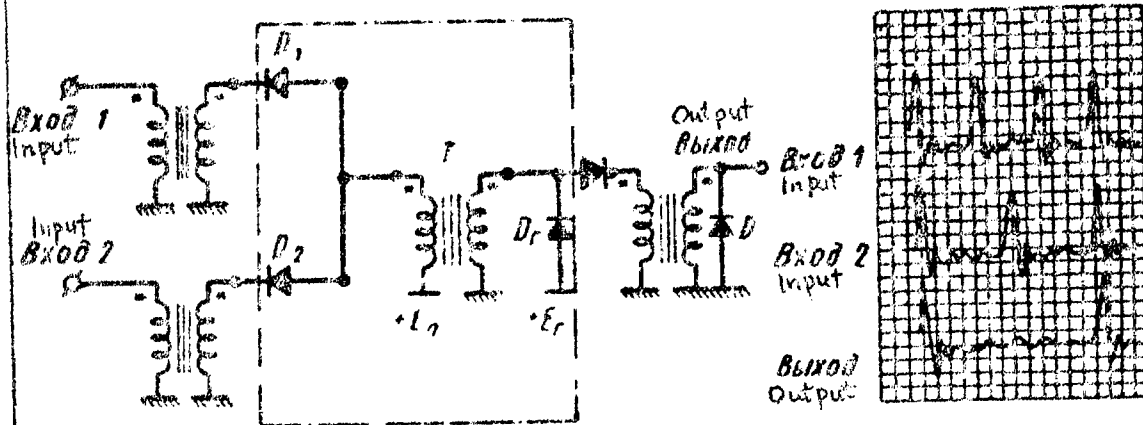

Figure 10. The circuit diagram of the logical element AND and the oscillograms of the pulses on the inputs and on the output.

The oscillogram shown in Figure 10 gives the results of the measurements in the case when germanium diodes DG-Ts8 are used. The power obtained from the direct-current source comprises about 0.5 millivolts (the voltage $E_d = 0.3$ volts; the current is 1.5 milliamperes). The voltage of the direct current power supply for the damping diode E_r also amounts to about 0.3 volts with the current of 1.5 milliamperes.

The examination of the oscillogram shows that the transmission ratio of the circuit AND is close to unity and the magnitude of the signal-to-interference ratio is satisfactory. The anti-coincidence

pulses on the input of this circuit undergo larger distortions than the coincidence pulses since in the circuit A, in addition to the load for the damping diode D_G , the anti-coincidence pulse is grounded by the diode D_1 or D_2 at which the pulse does not arrive at this instant of time.

The diode-transformer-type circuit A in which the logical operation AND is accomplished with the aid of the diodes D_1 and D_2 while the transformer T performs the functions of the output circuit, has sufficiently good electric characteristics and is convenient to design. For example, a circuit with three inputs is created by the addition of only one input diode. In this case it is necessary to place damping diodes at each input of the circuit AND (see Figure 3). However, because the anti-coincidence pulses are subjected to a heavier load and consequently become distorted, the circuit A cannot be recognized as being economical when operating with the signals of large amplitude. It may prove to be efficient for small signals since in this case the semiconductor diodes have high resistance and consequently their effect on the anti-coincidence pulses will be insignificant.

For the construction of the electric circuit with which the investigations of the logical element AND assembled according to the circuit diagram B (Figure 11) were conducted, the same transformers and diodes were used as in the preceding case. The study of the oscillograms shows that here a transmission ratio approaching unity may also

be obtained when the value of the signal-to-interference ratio is sufficiently high. Unlike the circuit A, the coincidence, i.e. the operating pulses are loaded in the circuit under consideration, which is normal. The circuit is comparatively economical: the power of the damping diode direct current comprises about 0.2 milliwatts, the voltage is 0.3 volts, the current - 0.5 milliamperes.

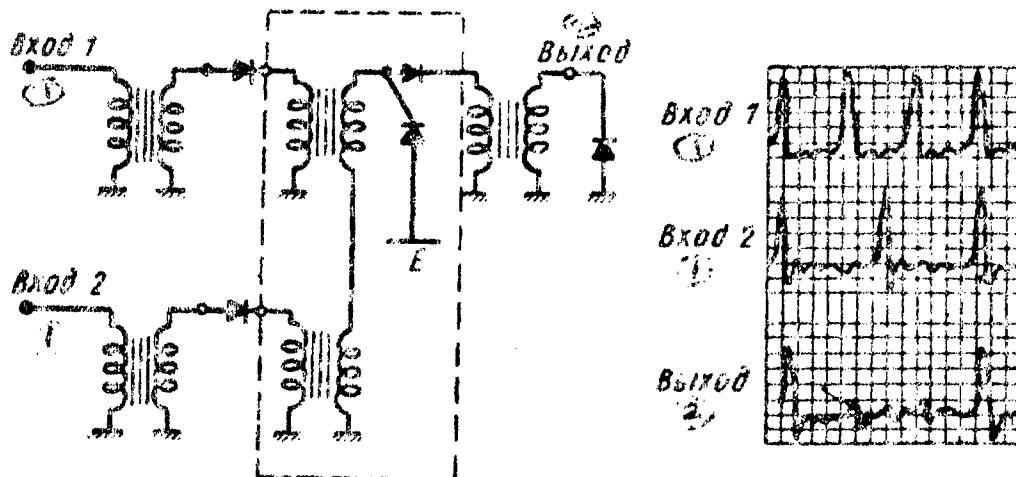

Figure 11. Circuit diagram B of the logical element AND and the oscillograms of the pulses on the inputs and on the output.

- (1) - Input
- (2) - Output

Thus, the diode-transformer circuit of the B type has sufficiently exact electric characteristics. However, since one of the transformers of the circuit AND represents a load for the other, this

circuit is more complex than circuit A with respect to the design and technology. The conditions of grounding the secondary windings are substantially different: the upper transformer is grounded through the winding of the lower transformer. The core of the transformer on the other hand, has a leakage to the ground through the distributed capacitance of the winding which is to some degree equivalent to the grounding of the transformer at midpoint. Therefore, upon the simultaneous appearance of the pulses on the serially connected secondary windings, the upper pulse partially compensates the lower pulse. Therefore, the aggregate pulse is smaller than the double amplitude of the pulses acting at a different time.

Let us examine, finally, the circuit C (Figure 12) in which the same transformers and diodes are used as in the first two circuits. Passing through the diode, the pulse arrives at one of the poles of the input winding of the transformer and another pulse is simultaneously inverted by 180° by one of the input transformers and after passing through the diode arrives at the second pole of the winding.

Upon the coincidence of the pulses, the transformer proves to be connected by both poles to the pulse sources, and in the case of anti-coincidence the transformer is connected to the pulse source by only one input pole. The second input pole of the transformer is grounded through the second diode of the circuit and the output winding of the second input transformer. Like the preceding circuit, this circuit does not require direct-current supply for its operation.

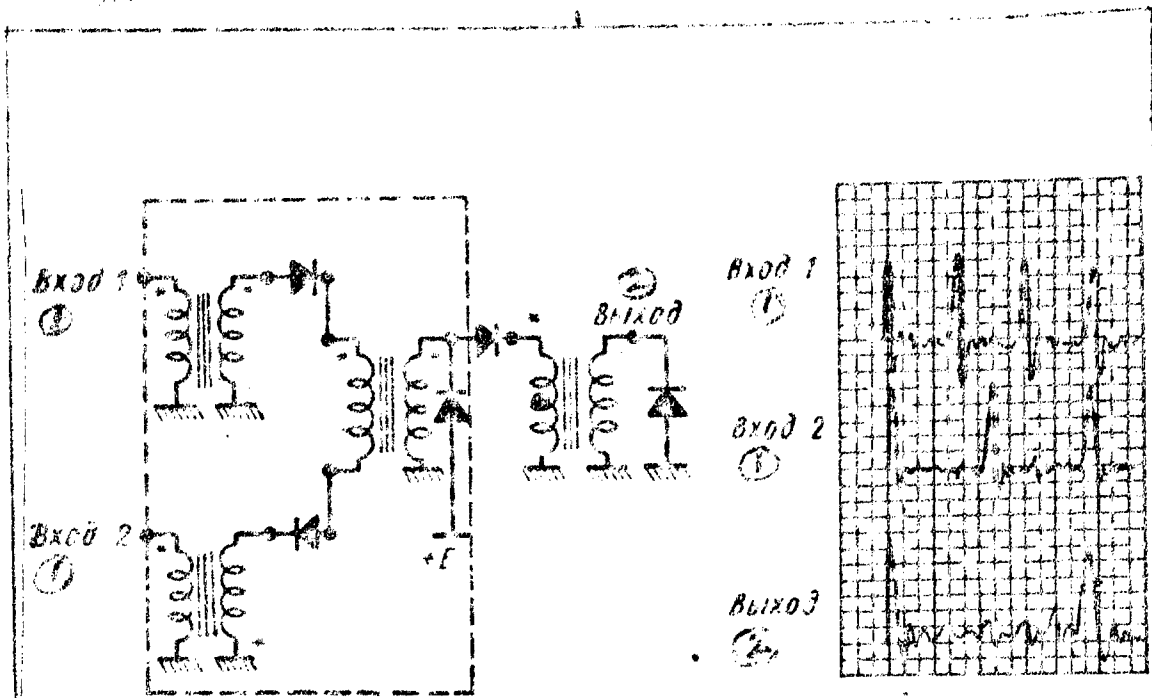

Figure 12. Circuit diagram C of the logical element ANE and the oscillograms of the pulses on the inputs and on the output.

- (1) - Input
- (2) - Output

The study of the oscillograms shows that the circuit weakly loads the input signals. The transmission ratio of this circuit is also close to unity. The signal-to-interference ratio for this circuit is considerably better than for the circuits considered above. With respect to the economy of the power supply, this circuit does not differ from the circuit B. Owing to the nonlinearity of the volt-ampere characteristic of the diodes, the conditions of the transmission of an anti-coincidence pulse are always poorer than in the case of the

coincidence pulses. Therefore this circuit is the most suitable one for the creation of the highly economical type AND circuits.

LOGICAL ELEMENT NOT. The logical operation NOT is performed by the electronic anti-coincidence circuit which has an input for the signal and an input for its inhibit. The circuit operates in the following manner. While there is no negating pulse on the inhibit input, the pulse appearing on the signal input passes to the output of the circuit. If however, simultaneously with the arrival of a pulse on the signal input, a pulse reaches the inhibit input, then no signal appears on the output. Thus, upon the addition of the inhibit input to any circuit OR or AND, this circuit is transformed into circuit NOT. As soon as the negating pulse appears, the passage of the signals to the output of the circuit is discontinued.

The diode-resistor-type circuit NOT shown in Figure 13 a [6] is considerably more complicated with respect to electricity than the similar circuits OR or AND. The signal which is to be inhibited is first delayed for a time equal to one fourth of the pulse duration. On the other hand, the negating pulse may pass through the delay line for a time equal to one half of the pulse duration but may also clear the delay line. As the result of this, the negating pulse arrives at the inhibit input of the circuit NOT before the signal pulse and continues longer.

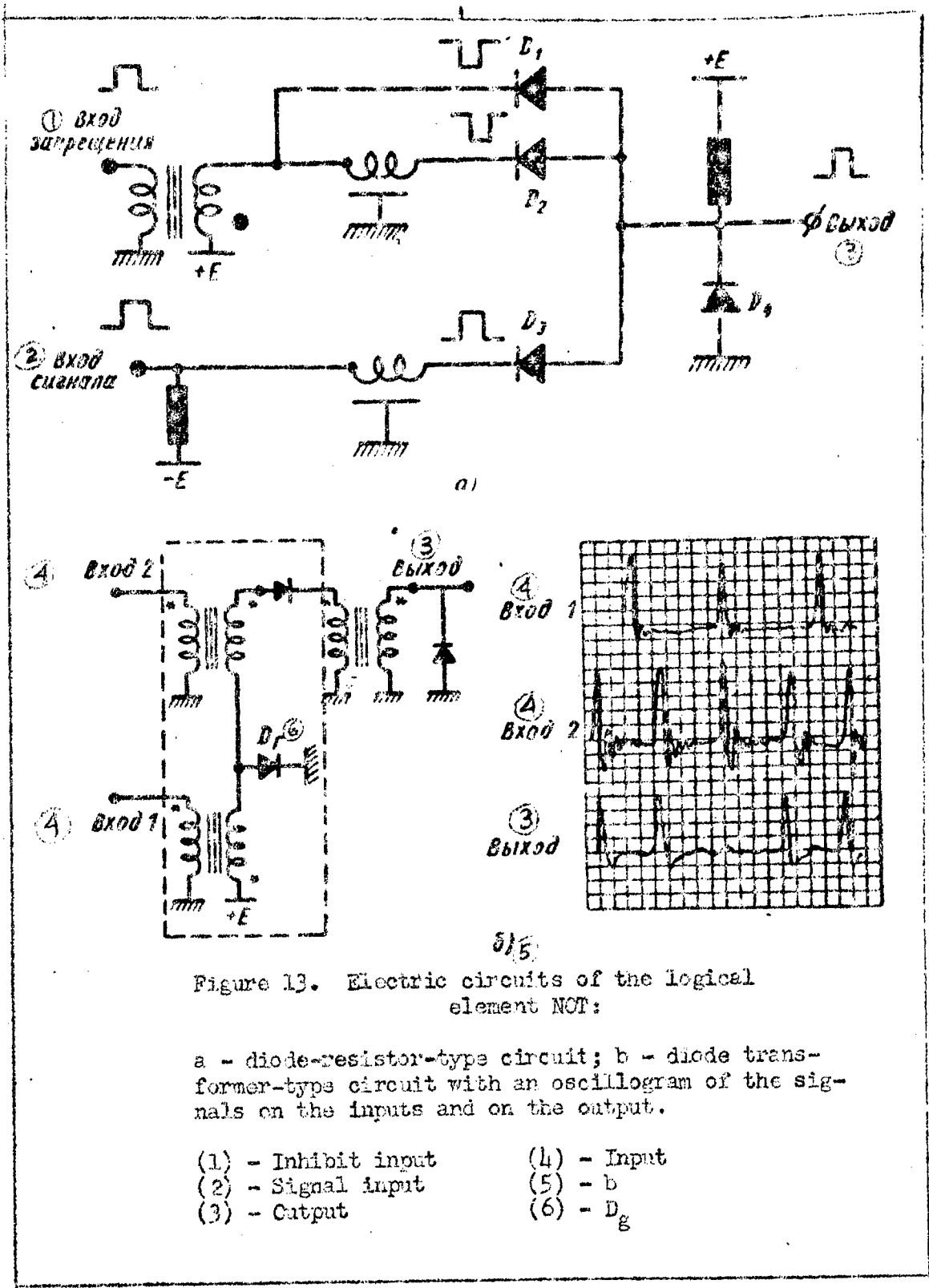

Figure 13. Electric circuits of the logical element NOT:

a - diode-resistor-type circuit; b - diode transformer-type circuit with an oscillogram of the signals on the inputs and on the output.

- | | |
|---------------------|-------------|
| (1) - Inhibit input | (4) - Input |
| (2) - Signal input | (5) - b |
| (3) - Output | (6) - D_g |

When the input pulses are absent the signal input is connected through the diode D_3 to the negative pole of the power supply and the diode D_4 keeps the output of the circuit below the ground potential. Diodes D_1 and D_2 are connected through the transformer to the positive pole of the power supply. If the voltage on the signal input becomes positive as the result of the arrival of the pulse and the negating pulse is absent on the inhibit input, then diode D_4 is cut off and the output voltage begins to rise until it is balanced and limited by the positive potential to which the diodes D_1 and D_2 are connected. If however, there is a negation pulse on the inhibit input, then, having been inverted by the transformer by 180° , it serves as the power supply of negative polarity for the diodes D_1 and D_2 . Owing to this, when the power of the negation pulse is sufficient, diode D_4 continues to conduct the current regardless of the presence of a pulse on the signal input.

The diode-transformer circuit of the logical element NOT [5] shown in Figure 13 differs little from the circuit B considered above. The difference is that the secondary windings of the transformers are connected in the opposing fashion and not in series, and the damping diode D_g is connected to the middle point of the circuit and not to the upper one. The opposing coils make it possible to compensate the operating signal by the inhibit signal. The damping diode connected to the middle point keeps one pole of the output coil of the signal transformer below the ground potential while there is no negation

pulse. Upon the arrival of the pulse diode D_g automatically switches this pole to the output of the inhibit transformer. For a reliable compensation of the signal, the pulse in the output winding of the inhibit transformer must be somewhat larger than the pulse amplitude in the output winding of the signal transformer. This is achieved by using a transformation ratio larger than unity.

With respect to the electric features the circuit NOT is not as good as the diode-transformer-type circuits of the other logical elements. The transmission ratio comes out to be somewhat less than unity. The circuit is sensitive to phase relationships. A necessary condition of its operation is that the inhibit pulse must arrive somewhat earlier than the signal pulse. However, the technical and economic characteristics of the transformer circuit NOT are considerably higher than in a similar circuit with a transformer and resistors (Figure 13 a) inasmuch as all the advantages of the diode-transformer circuits over the diode-resistor-type circuits remain in force.

ACCUMULATION CELL. The remarkable property of the diode-transformer logical elements (to transmit with small losses the signals representing the number or command codes) makes it possible to create efficient accumulation cells. When constructing cells with a semiconductor triode, it is expedient to use a delay line. In such a circuit the triode is intended chiefly for the compensation of damping in the delay line and for making up the small power losses in the

circuits of the logical elements. Such a circuit of the accumulation cell is more efficient than the other known circuits as for example the switching circuits utilizing the drooping region of the volt-ampere characteristic or the dynamic trigger circuits with memory capacitors.

When using a delay line, no special requirements are demanded with respect to the duration of the input signals, their amplitude etc. which is characteristic of the cases in which a reservoir capacitor or N-type characteristic are used. Since a storage cell can be used as an amplifier of low power, the semiconductor triode should be used in a circuit which provides a high input resistance.

The structural diagram of a storage cell (Figure 14) has three inputs: for the synchronizing pulses SI , for the zero setting pulse Y_0 and for the unity setting pulse Y_1 . The storage cell consists of

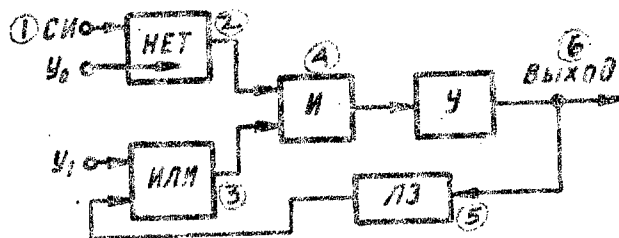

Figure 14. The basic diagram of a storage cell.

- | | |
|---------------------------------|-----------------------|
| (1) - SI - synchronizing pulses | (4) - AND |
| (2) - NOT | (5) - LZ - delay line |
| (3) - OR | (6) - Output |

input logical elements NOT and OR operating for the logical element AND which in its turn operates for the amplifier Y. There is a feedback from the amplifier output through the delay line IZ to the input circuit OR.

The synchronizing pulses serve for the reshaping of the input signals in time. For this purpose, the delay line is selected for a time somewhat shorter than the repetition time of the synchronizing pulses.

The zero setting signal is sent every time when it is necessary to store new data. It serves for the erasure of the information stored in the cell by blocking the delay line output from its input.

After an appropriate signal has been sent to the unity setting input, the electric circuit begins to operate as a pulse generator until new information is presented.

* *
*

Thus, the systems of the electronic automatic equipment in a high-speed computer can be constructed entirely of semiconductor devices of the existing types when pulse transformers with ferrite cores are used. The most complex electronic circuits of a computer can be assembled in the main from diode-transformer-type elements with a minimum use of the amplifiers. Therefore, such systems are characterized by high economy, high reliability and simplicity of operation.

BIBLIOGRAPHY

1. Bruce, G. D.; Logue, J. C. - An Experimental Transistorized Calculator. Electrical Engineering, Dec. 1955, 1044-1048.
2. Philco Develops Transistor Circuitry, Electrical World, 1955, 113, No. 13.
3. Transistorized Digital Computer. TRADIC Proves Reliable, Aviation Week, 1954, 61, No. 6, 46.
4. Zimin, V. A. - The High-Speed Electronic Computer of the Academy of Sciences USSR, part V, Standard Components of the BESM, Publication by the Academy of Sciences USSR, 1954.
5. Zimin, V. A. - Logical Circuits with Pulse Transformers and Semiconductor Diodes, Work of the Conference on the Methods of the Development of the Soviet Machine Building and Instrument Making, VINITI (All-Union Scientific Research Technical Institute ?), Moscow, 12-17 of March 1956.
6. Felker, J. H. - The Transistor as a Digital Computer Component. Review of Electronic Digital Computers Joint AIEE-IRE Computers Conference, Feb. 1952.

E N D