

**NAVAL POSTGRADUATE SCHOOL**  
**Monterey, California**



**THESIS**

**THE ARMY OIL ANALYSIS PROGRAM (AOAP): COST  
BENEFIT ANALYSIS OF MAINTAINING THE PROGRAM  
FOR GROUND SYSTEMS AT FORT HOOD, TEXAS**

by

Daniel J. Guilford

June 2000

Thesis Advisor:  
Associate Advisor:

Brad Naegle  
Bill Gates

**Approved for public release; distribution is unlimited.**

**DTIC QUALITY INSPECTED**

**20000721 028**

<b>REPORT DOCUMENTATION PAGE</b>			<i>Form Approved</i> OMB No. 0704-0188		
Public reporting burden for this collection of information is estimated to average 1 hour per response, including the time for reviewing instruction, searching existing data sources, gathering and maintaining the data needed, and completing and reviewing the collection of information. Send comments regarding this burden estimate or any other aspect of this collection of information, including suggestions for reducing this burden, to Washington headquarters Services, Directorate for Information Operations and Reports, 1215 Jefferson Davis Highway, Suite 1204, Arlington, VA 22202-4302, and to the Office of Management and Budget, Paperwork Reduction Project (0704-0188) Washington DC 20503.					
1. AGENCY USE ONLY (Leave blank)		2. REPORT DATE June 2000	3. REPORT TYPE AND DATES COVERED Master's Thesis		
4. TITLE AND SUBTITLE : The Army Oil Analysis Program (AOAP): Cost Benefit Analysis of Maintaining the Program for Ground Systems at Fort Hood, Texas			5. FUNDING NUMBERS		
6. AUTHOR(S) Guilford, Daniel J.					
7. PERFORMING ORGANIZATION NAME(S) AND ADDRESS(ES) Naval Postgraduate School Monterey, CA 93943-5000			8. PERFORMING ORGANIZATION REPORT NUMBER		
9. SPONSORING / MONITORING AGENCY NAME(S) AND ADDRESS(ES) N/A			10. SPONSORING / MONITORING AGENCY REPORT NUMBER		
11. SUPPLEMENTARY NOTES The views expressed in this thesis are those of the author and do not reflect the official policy or position of the Department of Defense or the U.S. Government.					
12a. DISTRIBUTION / AVAILABILITY STATEMENT Approved for public release; distribution is unlimited.			12b. DISTRIBUTION CODE A		
13. ABSTRACT (maximum 200 words) The purpose of this thesis is to analyze the costs and benefits of maintaining the Army Oil Analysis Program (AOAP) at Fort Hood, Texas. Research will analyze the AOAP requirements, review both the current costs associated with executing the program and the potential or realized benefits gained from the program, and conduct a cost and benefit analysis of maintaining the program for ground systems at Fort Hood, Texas. This research will provide the information required to determine if the Army should maintain the AOAP at Fort Hood, Texas. It will also serve as a basis for either reexamining the program throughout the Army or for increasing investment by the Army into the program. This thesis concludes that the AOAP provides a net positive benefit to Fort Hood and the Army.					
14. SUBJECT TERMS Logistics Support, Spectrometric Analysis, Ferrographic Analysis			15. NUMBER OF PAGES 150		
			16. PRICE CODE		
17. SECURITY CLASSIFICATION OF REPORT Unclassified	18. SECURITY CLASSIFICATION OF THIS PAGE Unclassified	19. SECURITY CLASSIFICATION OF ABSTRACT Unclassified	20. LIMITATION OF ABSTRACT UL		

NSN 7540-01-280-5500

Standard Form 298 (Rev. 2-89)  
Prescribed by ANSI Std. Z39-18



Approved for public release; distribution is unlimited

**THE ARMY OIL ANALYSIS PROGRAM (AOAP): COST BENEFIT ANALYSIS  
OF MAINTAINING THE PROGRAM FOR GROUND SYSTEMS AT FORT  
HOOD, TEXAS**

Daniel J. Guilford  
Major, United States Army  
B.S., University of Kentucky, 1987

Submitted in partial fulfillment of the  
requirements for the degree of

**MASTER OF SCIENCE IN MANAGEMENT**

from the

**NAVAL POSTGRADUATE SCHOOL**  
June 2000

Authors:

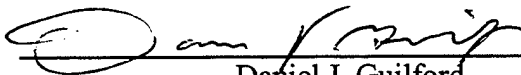

Daniel J. Guilford

Approved by:

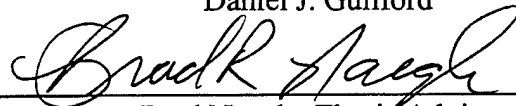

Brad Naegle, Thesis Advisor

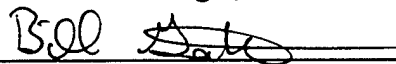

Bill Gates, Associate Advisor

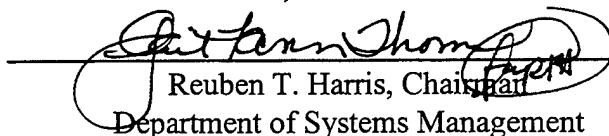

Reuben T. Harris, Chairman  
Department of Systems Management



## ABSTRACT

The purpose of this thesis is to analyze the costs and benefits of maintaining the Army Oil Analysis Program (AOAP) at Fort Hood, Texas. Research will analyze the AOAP requirements, review both the current costs associated with executing the program and the potential or realized benefits gained from the program, and conduct a cost and benefit analysis of maintaining the program for ground systems at Fort Hood, Texas. This research will provide the information required to determine if the Army should maintain the AOAP at Fort Hood, Texas. It will also serve as a basis for either reexamining the program throughout the Army or for increasing investment by the Army into the program. This thesis concludes that the AOAP provides a net positive benefit to Fort Hood and the Army.



## TABLE OF CONTENTS

I.	INTRODUCTION .....	1
	A. PURPOSE .....	1
	B. BACKGROUND .....	1
	C. SCOPE AND METHODOLOGY.....	2
	1. Scope.....	2
	2. Methodology.....	3
II.	OVERVIEW OF THE ARMY OIL ANALYSIS PROGRAM (AOAP).....	5
	A. CHAPTER PURPOSE.....	5
	B. INTENT OF THE AOAP.....	5
	C. SAMPLING PROCESS .....	8
	1. Sampling at the Unit .....	8
	2. Samples at the Lab .....	11
	D. LABORATORY TESTING.....	13
	E. LABORATORY REQUIREMENTS .....	21
	1. Personnel.....	21
	2. Quality.....	23
	a. Evaluator Certification .....	23
	b. Certification Program.....	24
	F. CHAPTER SUMMARY .....	26

III.	COSTS OF AOAP .....	29
A.	CHAPTER PURPOSE AND INTRODUCTION .....	29
B.	SUPPORTED EQUIPMENT POPULATION.....	30
1.	Categorizing Samples .....	30
2.	Population Determination .....	32
a.	Percentage of Non-Ground Systems.....	32
b.	Determination of Ground System Populations .....	34
c.	Representative Systems .....	38
C.	COST OF CONTRACTOR .....	39
D.	GOVERNMENT COST OF CONTRACT .....	40
E.	LAB MATERIALS .....	42
F.	OVERHEAD .....	43
G.	EQUIPMENT COSTS .....	44
H.	SAMPLING COSTS.....	46
1.	Personnel.....	46
2.	Material Costs .....	48
I.	COST OF RECOMMENDATIONS .....	50
J.	COST OF QUALITY .....	53
K.	CHAPTER SUMMARY .....	55
IV.	BENEFITS OF AOAP.....	57
A.	CHAPTER PURPOSE AND INTRODUCTION.....	57

B.	ENVIRONMENT.....	57
C.	MAINTENANCE.....	59
D.	READINESS.....	60
E.	LEARNING FROM OIL ANALYSIS.....	61
F.	SAVINGS IN LIVES AND HEALTH.....	63
G.	AVOIDED OIL CHANGES.....	65
H.	PERCEIVED BENEFITS.....	71
I.	CHAPTER SUMMARY.....	72
V.	COST-BENEFIT AND SENSITIVITY ANALYSES.....	73
A.	PURPOSE.....	73
B.	COST-BENEFIT ANALYSIS.....	73
C.	SENSITIVITY ANALYSIS.....	75
1.	Assumptions.....	75
2.	Analysis.....	76
D.	CHAPTER SUMMARY.....	79
VI.	CONCLUSION AND RECOMMENDATIONS.....	81
A.	CHAPTER PURPOSE.....	81
B.	CONCLUSION.....	81
C.	RECOMMENDATIONS.....	83
D.	AREAS FOR FURTHER RESEARCH.....	84
	APPENDIX A. DA FORM 3254-R.....	87

APPENDIX B. DA FORM 5991-E .....	89
APPENDIX C. WEAR METAL CONCENTRATION VS. OPERATING HOURS BASED ON REPLENISHMENT OF DEPLETED OIL.....	91
APPENDIX D. EFFECT OF PERIODIC FLUID ADDITION AND FLUID CHANGE ON WEAR METAL CONCENTRATIONS .....	93
APPENDIX E. LABORATORY RECOMMENDATION CODES BASED ON SPECTROMETRIC ANALYSIS .....	95
APPENDIX F. PHYSICAL TEST RECOMMENDATION CODES.....	97
APPENDIX G. EXAMPLE OF ALLOWED WEAR METAL CONCENTRATION FOR SPECIFIC COMPONENT.....	99
APPENDIX H. EXAMPLE LUBRICATION CONTAMINATIONS AND ASSOCIATED METHOD FOR ANALYSIS DETECTION.....	101
APPENDIX I. DRAIN KIT FOR TAKING OIL SAMPLES .....	103
APPENDIX J. WEAR METAL CONCENTRATIONS VS. OPERATING HOURS .	105
APPENDIX K. OASIS PICTORIAL REPRESENTATION.....	107
APPENDIX L. CATEGORIZATION OF EQUIPMENT AND POPULATION DETERMINATION .....	109
APPENDIX M. SAMPLE CORRELATION TEST REPORT MESSAGE.....	117
APPENDIX N. CORRELATION SCORING.....	119
APPENDIX O. AOAP RECOMMENDATION SEQUENCE.....	121
APPENDIX P. OIL CHANGE DATA .....	123

APPENDIX Q. TYPE OF WEAR METALS AND SOURCES .....125

APPENDIX R. SENSITIVITY ANALYSIS .....127

LIST OF REFERENCES.....131

INITIAL DISTRIBUTION LIST.....135



## LIST OF TABLES

TABLE 2.1. LIST OF WEAR METALS.....	14
TABLE 3.1a. DETERMINING POPULATION.....	33
TABLE 3.1b. DETERMINING POPULATION.....	33
TABLE 3.2. POPULATION ON FORT HOOD.....	38
TABLE 3.3. REPRESENTATIVE SYSTEMS.....	38
TABLE 3.4. NUMBER OF SAMPLES AND OIL COSTS.....	49
TABLE 3.5. RECOMMENDED OIL CHANGES.....	51
TABLE 3.6. CERTIFICATION SCORES.....	53
TABLE 3.7. SUMMARY OF COSTS.....	56
TABLE 4.1. ADDITIONAL OIL CHANGE DATA.....	67
TABLE 4.2. COSTS AVOIDED BY SYSTEM.....	69
TABLE 4.3. SUMMARY OF BENEFITS.....	72
TABLE 5.1. VARIABLE COSTS.....	74
TABLE 5.2. SENSITIVITY ANALYSIS.....	77



## **I. INTRODUCTION**

### **A. PURPOSE**

This research will analyze the costs and benefits of maintaining the Army Oil Analysis Program (AOAP) at Fort Hood, Texas. Research will analyze the AOAP requirements, review both the current costs associated with executing the program and the potential or realized benefits gained from the program, and conduct a cost and benefit analysis of maintaining the program for ground systems at Fort Hood, Texas.

This research will provide the information required to determine if the Army should maintain the AOAP at Fort Hood, Texas. It will also serve as a basis for either reexamining the program throughout the Army or for increasing investment by the Army into the program.

### **B. BACKGROUND**

The Army initiated the Army Oil Analysis Program (AOAP) in 1961. The program was first applied to aircraft systems due to safety concerns. The goal was to minimize the risk of injuries and deaths due to catastrophic failures of aircraft components while in flight. In theory, by sampling oil used in the system's critical components, such as engine and transmission, the oil analysis program hoped to identify imminent failures of components. This would then allow for preventive maintenance actions before further operating the identified aircraft. This would minimize the potential

for the components to fail and cause catastrophic damage, potentially injuring or killing the pilot, crew, or passengers. [Ref. 9]

In addition to minimizing crash risks, the AOAP allowed units to extend the intervals between oil changes. This was potentially a great cost savings to the units in the field. Because of these potential savings, ground systems were included in the program in 1974. As more systems began entering the program, the cost savings from reducing intervals between oil changes helped offset some of the funding reductions that units were experiencing. [Ref. 9]

## **C. SCOPE AND METHODOLOGY**

### **1. Scope**

The scope of this research will include the following aspects with respect to ground systems:

1. A literature review on the AOAP.
2. An in-depth review of the AOAP process.
3. A review of the laboratory testing procedures.
4. An analysis of the costs and benefits of the program.
5. A cost-benefit analysis of maintaining the program at Fort Hood, Texas.

The thesis will conclude with a recommendation on maintaining the AOAP for both ground systems at Fort Hood, Texas and the Army as a whole. This thesis will also attempt to answer the following questions:

1. What is the AOAP?
2. Does the AOAP at Fort Hood, Texas provide the Army a cost savings?
3. What are the requirements to maintain systems on the program?

4. What are the costs associated with maintaining the AOAP for ground systems at Fort Hood, Texas?

5. What are the cost/benefit relationships of participating in the AOAP at Fort Hood?

## **2. Methodology**

The methodology used in this thesis research will consist of the following steps:

1. Conduct a literature search of books, periodicals, CD-ROM system, and other library information resources.

2. Conduct a thorough review of the AOAP processes, hardware requirements, management requirements, and standards.

3. Conduct telephonic interviews to gather cost data and determine other program costs and benefits.

4. Conduct a detailed study of the Fort Hood laboratory's CY1999 sampling records with recommendations.

THIS PAGE INTENTIONALLY LEFT BLANK

## **II. OVERVIEW OF THE ARMY OIL ANALYSIS PROGRAM (AOAP)**

### **A. CHAPTER PURPOSE**

This chapter is designed to provide the reader with a basic understanding of the AOAP's intents, processes, and requirements. Details are discussed sufficiently to enable a clearer understanding of the costs and benefits discussed in follow-on chapters.

### **B. INTENT OF THE AOAP**

There are many reasons for implementing an oil analysis program. These reasons range from saving money to reducing risk of human injury. These intents are discussed below (in no particular order) and will be readdressed as to their monetary costs and benefits in chapters three and four.

One of the intents of oil analysis is to detect impending equipment failures and conduct maintenance at a lower level than that required in the event of a catastrophic failure. [Ref. 14: p. 3] If the component is allowed to fail catastrophically, there is potential for the component to require significantly more maintenance. [Ref. 38] If catastrophic failure is reached inside a high compression engine, there is potential for metal to shear and cause damage to other engine components. This may result in the engine being repaired at depot level instead of Direct Support (DS) level. [Ref. 9] Although Fort Hood has both types of maintenance capabilities on post, [Ref. 20] the

depot cost of performing tasks are generally higher than identical tasks performed at DS level. [Ref. 13]

Another intent is to provide a quality assurance tool for component repair or overhaul. [Ref. 7: Sec 3, b] When the AOAP results identify a potential failure, the component is either diagnosed at the unit or is sent to the appropriate level of maintenance. With the AOAP's diagnostic assistance, the mechanics at that level can disassemble the component and replace only that portion identified by the AOAP analysis. By having this focus, there is decreased probability that the mechanic will mistakenly diagnose the problem. This can cause unneeded parts to be ordered and replaced. Even after unneeded parts are replaced, the problem is not resolved and causes the diagnostic effort to be re-initiated. This can occur at any level from unit to depot level maintenance. [Ref. 9]

A third intent is to determine lubricant condition, such as the quality and ability of the lubricant to perform its designed function. [Ref. 14: p. 3] This allows the units to change their oils when they are no longer able to lubricate the components, rather than using a set mileage, hour, or time requirement. This reduces material and time costs associated with changing oils. [Ref. 9]

By-products of changing oils based on set intervals are the reduced potential for environmental impacts and the reduced costs of carrying oil. Environmental impacts occur whenever oil is spilled and is not cleaned-up. The costs of carrying oil include storage space, ordering replenishment, transporting, and maintaining stocks. [Ref. 9]

AOAP is also intended to reduce maintenance downtime hours through early detection. [Ref. 14: p. 5] This allows the unit to schedule troubleshooting and maintenance, rather than reacting to a system failure at an inopportune time. As an example, a unit would be able to inspect the coolant system for suspected intrusion into the oil system, instead of the coolant causing the engine to fail while conducting a field exercise. The identification of potential failures allows the system to move under its own power into a maintenance bay instead of requiring a recovery vehicle to tow the system to a maintenance location. Maintenance personnel are then able to focus on the identified problem instead of conducting a lengthy fault diagnosis. In an extreme example, the seals and lubricants are replaced which extends the life of the engine instead of replacing the entire engine. The avoidance of recovering a vehicle, conducting lengthy diagnosis, and replacing engines all reduce the time that that system is non-operational and reduces manpower requirements to correct the failure. Avoiding these cases, allows units to maximize their use of resources when they are training, directly improving operational readiness. [Ref. 9]

Another significant objective is to promote safety. Identifying failures before they become catastrophic minimizes the risk to human life. [Ref. 7: Sec 3, b] Although this is not as significant in ground equipment as it is for aircraft, there is still potential for ground systems to be hazardous to the crew and bystanders during a catastrophic failure. For instance, the failure of a light skinned vehicle's engine while in a convoy could place it at risk for an accident with trailing vehicles or cause the driver to lose control. This is

particularly important in high dust areas, such as the desert, where it is difficult to see vehicles in front and to the rear. Additional hazards are present when the vehicle component's destruction may throw parts or shrapnel. [Ref. 9]

The program has the intent of increasing the effectiveness of oil analysis as a diagnostic tool. [Ref. 3: p. 1-2] The more oil analysis is performed, the better oil analysis can help to improve the quality of the assessments. This is not only accomplished by improving oil analysis, but also by better understanding the equipment being monitored to determine normal wear patterns and make improved recommendations. [Ref. 9]

Lastly, oil analysis is designed to collect engineering data for each phase of a weapon system's life. [Ref. 3: p. 1-2] This allows the system managers to improve their systems. By discovering when a particular item fails and how it progressively fails, designers are able to determine where the item can be improved. [Ref. 9]

## **C. SAMPLING PROCESS**

### **1. Sampling at the Unit**

The first part of the sampling process is to determine how often routine sampling is required. For an active Army unit's combat vehicle engines and transmissions, sampling typically occurs at 25 hours of operation or 60 days, whichever occurs first. [Ref. 2: Sec 4-11, a] However, each piece of equipment may have specific prescribed sampling intervals for its components. For example, the M1 sampling interval for transmissions is set at 75 hours or 90 days. [Ref. 2: Sec 4-11, a] The specific Lubrication

Order (LO) for the designated End Item Model (EIMOD) should be referenced to ensure proper sampling intervals for that particular model. There is, however, a 10% variance allowed before or after the scheduled date, hours, or miles. [Ref. 2: Sec 4-5, a] This allows commanders to direct samples be taken during regularly scheduled maintenance days without increasing the workload by sampling during training missions. Special samples are also taken when the following conditions exist: [Ref. 2: Sec 4-5, b]

1. At the request of the laboratory.
2. Immediately before transfer among commands or overseas deployment.
3. After maintenance overhaul or replacing a component.
4. After indication of a problem, for example overheating, excessive oil loss, or loss of pressure.
5. After indicating contamination (sample is cloudy, contains sludge, or excessive dirt).
6. When deemed necessary by the unit commander. [Ref. 14: p. 4]

The next step is for the unit to track this information to maintain proper intervals. Information on usage (miles and/or hours) is kept in the equipment's historic records. [Ref. 2: Sec 5-1, a] Today, these are typically maintained on the Unit Level Logistics System (ULLS) computers that enable the clerks to printout all systems that have met or are close to meeting their prescribed intervals. The clerk then delivers the report to the unit maintenance officer who directs that due samples be completed during that maintenance period. [Ref. 13]

The third step involves soldiers gathering the sample containers and physically taking samples. Almost all Army systems have installed sampling kits to increase the probability that the sample is collected from a representative point and to minimize the risk of foreign material entering the sample. [Ref. 13] As long as the equipment has

operated within the last thirty days, the soldier can immediately take a sample. If it has not, the soldier must first bring the equipment to normal operating temperature. [Ref. 2: Sec 4-7, a]

For each sample, the soldier must bleed-off sufficient oil to ensure that the line is free of sediment. [Ref. 3: p. 3-7] This usually drains approximately 3 ounces (the volume of a sample container) as waste oil (see Appendix I). The soldier collects the waste oil in a separate container and inserts the sample container under the nozzle when the fluid appears consistent. The soldier then provides the clerk with the sample container and additional information including the vehicle miles and/or hours at the time of the sample. [Ref. 13]

The clerk then completes the ULLS DA Form 5991-E (see Appendix B) and delivers the samples to the AOAP lab. Most of the form's data is automatically input from the ULLS database. [Ref. 13] However, there are several items the clerk must input into the computer to ensure the lab receives the proper information. This information includes, at a minimum: [Ref. 3: Sec 3-6]

1. The nature of the sample (routine or special). Routine occurs at the normal sampling interval; special is for lab requested resample or reasons other than normal interval.
2. Replacement of any AOAP monitored components.
3. Changes or additions, with quantity added, of oil to the component.
4. Incidents including over-temperature, abnormal pressures, or over-speeds that could affect oil wetted parts subject to wear.
5. The date and time of the sample.
6. The hours and miles at time of the sample.

If the sample is a special sample, it must be so identified. These special samples must be banded with red tape to clearly identify the sample. The borders of the ULLS DA Form 5991-E must also be marked in red to help the lab to quickly identify them. [Ref. 14: p. 10]

After the results are received from the laboratory, the report must be maintained with the equipment. Because the Fort Hood lab is automated, the minimum requirement is to maintain the results of the last lab sample analyzed. [Ref. 2: p. 86]

## **2. Samples at the Lab**

The lab's first task each day is to perform standardization checks on the test equipment to ensure that each piece is functioning correctly. These standardization checks are again performed throughout the day, as necessary, to maintain the performance of the test equipment. [Ref. 10] At a minimum, these checks must be performed when the lab transitions between aeronautical and non-aeronautical samples. [Ref. 4: p. 3-1]

The lab's first step after receiving the samples is to input the data from the sample into the Oil Analysis Standard Interservice System (OASIS). [Ref. 4: p. 3-6] This is a computer system that accelerates the sample processing cycle. It provides a means for the lab to maintain the historical sampling records on site and quickly compare trends. It also allows the lab to automatically generate reports. [Ref. 14: p. 15] (See Appendix K for picture description of OASIS).

As tests are performed on the sample, the results are sent directly from the test equipment to OASIS. The sample's file is then updated and saved onto the file server. As the testing process proceeds, OASIS guides the lab technicians on which tests to perform. After all the tests are completed, OASIS compares the historic files and guidelines for that component to the sample's results to identify any variances and make recommendations. [Ref. 9]

The lab has deadlines for analyzing the samples and reporting the results. For normal sampling, the lab results must be completed within 72 clock hours (three workdays) of when the sample arrived, excluding weekends or holidays. For a special sample, the lab is required to respond within 24 hours. [Ref. 14: p. 39] Although these same times are applicable to aeronautical equipment, the Fort Hood lab places top priority on processing these samples due to the aircraft non-operational status until the results are received. [Ref. 10]

After the lab analyzes the sample, OASIS composes a report and the lab prepares to send it to the unit, either by electronic or printed report. Before the results are sent, one of the lab's evaluators must review the results. If the evaluator feels that OASIS has mis-analyzed the sample, the evaluator accesses the historic records from the OASIS system to verify the results and forwards the report. [Ref. 9] The report is an electronic equivalent to the DA Form 3254-R that reports findings to the unit and suggests corrective actions based on the oil sample analyzed. [Ref. 14: p. 28] In addition, the

OASIS sends the results via modem to the AOAP Program Office in Redstone Arsenal, Alabama. [Ref. 9]

After the unit receives the report, they must complete block 14 of the DA Form 3254-R with a narrative describing the action taken and return the form to the lab within five days of completing the action. [Ref. 14: p. 28] If the lab requests a resample, the unit is not to operate the equipment and must resample and submit to the lab within 72 hrs. [Ref. 14: p. 10] Typically, the lab will be able to determine if its recommendations were not followed. [Ref. 14: p. 40]

The lab's final task in the sampling process is to clean the sample containers. Any remaining oil is discarded [Ref. 10] into a 55-gallon container [Ref. 12]. The sample containers are washed with a non-hazardous solvent, [Ref. 10] which is again discarded into the same 55-gallon container [Ref. 12]. The clean sample containers are then made available to the units for use in the next samples. [Ref. 10]

#### **D. LABORATORY TESTING**

Oil analysis is a diagnostic tool [Ref. 3: p. 1-1] used to determine when components are failing and when oils are no longer able to lubricate the components they were designed to protect. This is accomplished by a series of tests, which includes spectrometric [Ref. 14: p. 4-3], physical property [Ref. 14: p. 4-1], and potentially ferrographic testing. [Ref. 10] Each of these tests is designed to provide feedback on different aspects of the oils being tested.

The Spectrometric test is typically the first test performed on the oil sample. [Ref. 4: Fig. 4-2: p. 4-4] This test determines the type and amount of wear metals present in the lubrication oil samples. It performs this task by energizing the atoms in the samples to emit radiant energy. Either a prism or diffraction grating then disperses this radiant energy. It emerges in a spectrum of light whose pattern is determined by the atoms of the excited elements. Atoms of each element contain different electronic configurations, so each has a distinct and characteristic spectrum occurring at different wavelengths. The characteristic lines emitted identify the elements found in the sample. The concentrations can be determined by quantitatively analyzing each line's brightness. This process is capable of detecting and measuring concentrations of 20 different wear metals, which are listed in Table 2.1. [Ref. 16: p. 1-21]

Iron (Fe)	Silver (Ag)	Aluminum (Al)	Chromium (Cd)	Copper (Cu)
Boron (B)	Barium (Ba)	Nickel (Ni)	Molybdenum (Mo)	Silicon (Si)
Tin (Sn)	Titanium (Ti)	Magnesium (Mg)	Beryllium (Be)	Cadmium (Cd)
Lead (Pb)	Zinc (Zn)	Sodium (Na)	Manganese (Mn)	Vanadium (V)

**Table 2.1. List of Wear Metals**

Wear metals are created by friction between metallic surfaces that are in motion relative to each other in mechanical systems. Even when oil is present and lubricating as designed, wear metal is generated. These wear metals are then placed in suspension within the lubricant. Wear metals can also be generated when water causes the component to corrode. [Ref. 3: p. 2-1]

Using wear metals to diagnose the component helps determine what part of the component is potentially failing. As a portion of the component begins to experience wear, there are larger concentrations of that wear metal in the oil samples. Although there may be many portions of the component made from the same metal, the presence of a unique metal such as silver can quickly allow technicians to determine the possible areas from which the wear metal originated. [Ref. 3: p. 2-1] As in this case, silver is used as plating on some oil seals, oil bushings, and sleeve bushings (see Appendix R for a list of wear metal sources). [Ref. 6: p. 2-2] Wear metals typically increase at a constant rate, depending on when in the component's life the sample is taken. During the initial break-in period of a new component, there are usually larger increases in concentrations of wear metals. Appendix J, "Wear Metal Concentrations Vs. Operating Hours," depicts a theoretical plot of wear metal concentrations in conjunction with operating hours in closed systems where there is no fluid consumption. [Ref. 3: p. 2-1]

Although there are several types of spectrometers used in AOAP labs, the Fort Hood lab uses an Atomic Emission (A/E) Spectrometer. This is capable of analyzing a maximum of 72,000 samples annually. This is based average use of eight hours a day and 20 workdays per-month. [Ref. 20]

There are also limitations to the spectrometric test's ability to detect failures. The spectrometer cannot detect metal fatigue. As metals fatigue, the probability increases that the component will fail catastrophically. The spectrometer is also unable to detect large particles when there is no accompanying normal wear metal generation. [Ref. 3: p. 2-3]

If large particles are detected during a lab technician's visual inspection, the technician performs a Ferrographic Analysis. This test is primarily used for aeronautical samples and is not usually performed on ground equipment. [Ref. 20] "The Ferrographic analysis determines size, shape, and type of wear metal particles in the sample and mode of wear (spalling, rubbing, and cutting) which produces the particles." [Ref. 21]

For Ferrographic analysis, the sample is first heated to 149 degrees Fahrenheit and shaken until the sediment appears homogeneously suspended. Exactly 1 ml of sample is then mixed thoroughly with 2 ml of solvent. [Ref. 4: p. 4-33] This allows the mixture to flow more quickly through a tube that is placed inside a magnetic field gradient. [Ref. 5: p. 2-6A] This causes both large and small wear metals to align and fix to the inside of the tube. Additional solvent is poured over the particles to remove any residual oil. After the tube dries, it is analyzed by the Direct Reading (DR) Ferrograph. [Ref. 4: p. 4-32] If the DR guidelines are exceeded, a ferrogram is developed.

The ferrogram is developed using the same steps as above, except a slide is used instead of a tube. The ferrogram is analyzed using a ferroscope (bichromatic microscope) along with various lighting and heat techniques. The resultant colors and shapes determine size, shape, type, and amount of wear material. [Ref. 5: p. 2-6A] One Ferrographic Microscope is capable of analyzing a maximum of 5,760 DR Ferrographs and 1,920 ferrograms annually. [Ref. 20]

The physical tests consist of a number of various procedures. [Ref. 4: Fig. 4-2: p. 4-4] These physical tests include the Crackle, Viscosity, Blotter, Flash Point (Setaflash),

[Ref. 16: pp. 1-33 & 2-43] and Karl Fisher test.[Ref. 4, Fig. 4-2: p. 4-4] The table in Appendix H lists various contaminants and the associated tests that indicate the contaminants presence. [Ref. 4: p. 4-3]

The Crackle test is performed with a hot plate. This hot plate is set at a temperature of 300 to 350 degrees Centigrade (150 to 175 degrees Fahrenheit). A drop of the oil sample is placed on the plate. If there is an audible crackling and spattering noise, then water is contaminating the sample. [Ref. 6: p. 1-33] Water could either be from the coolant, free water, or dissolved water. [Ref. 4: Fig 4-2: p. 4-4] Coolant contamination is accompanied by sodium or boron, identified using the spectrometer. An increase in one of these elements exceeding 20 Parts Per-Million (PPM) is reason to suspect a coolant leak. These high levels or sudden increases in sodium or boron will not accompany free water from condensation. [Ref. 4: p. 5-15]

The Karl Fischer test can identify the exact amount of water contamination. [Ref. 4: p. 4-15] The Karl Fischer test introduces the proper amount of the sample into a measuring device and weighs the sample. When the weight is calculated, the device can display the PPM of water in the sample. [Ref. 4: p. 4-15]

The oil's viscosity is determined using a Viscometer. The Viscometer's vibrating sphere is immersed in the sample and a reading is taken. If the reading is too low, it may indicate that there is fuel dilution, lubricant degradation, or other contamination. [Ref. 16: p. 1-33] This finding is generally verified by using the flash point test. If the Viscometer

reading is too high, there could be sludge, soot, or water contamination. This finding is verified by the blotter test. [Ref. 4: Fig. 4-2: p. 4-4]

The Blotter test is used to measure insoluble contaminants, dispersant ability, and alkalinity [Ref. 16: p. 1-34] in engine samples. [Ref. 4: p. 4-3] Dispersancy is a characteristic that allows oil to keep contaminants suspended rather than depositing them on engine surfaces. [Ref. 4: p. 4-11] This is measured by placing one drop of oil in the center of an oil print filter circle. The spot is allowed to develop for 15 minutes. The resultant spot is evaluated for total contaminants, cooling contamination, and dispersant effectiveness. [Ref. 16: p. 1-34] Generally, the greater the size of the spot relative to the initial spot, the greater the oil's dispersancy. If the resultant spot shows a sudden decrease in contaminants from the previous sample, this indicates a loss of dispersancy. The cause could either be an actual loss of dispersancy or it could indicate the unit changed the oil without notifying the laboratory. In either case, it will result in a recommendation to change the oil and filter. [Ref. 4: p. 4-12] After the spot has been evaluated, an alkalinity indicator is added to the spot. After one or two minutes, the alkaline reserve is determined by the color ring that develops. [Ref. 16: p. 1-34]

The flash point test determines the amount of fuel dilution by reading the temperature and barometric pressure at which the sample flashes. [Ref. 4: p. 4-22] Flash point is the lowest temperature at which the specimen's vapor ignites in a flash when a test flame is applied. [Ref. 4: p. 5-15] This is measured by bringing the test equipment's sample well temperature to a stable 295 degrees Fahrenheit. Then, 4 ml of sample are

inserted into the machine. When the sample flashes, the corresponding temperatures and barometric pressures are read. This allows the technicians to determine the amount of fuel dilution. [Ref. 4: p. 4-22]

With constant improvements in technology, the Fort Hood lab no longer needs to perform the multitude of physical tests described above. The Fourier Transform Infrared (FT-IR) Spectrometer replaces all of the physical tests. This not only saves time in processing samples, but also reduces some of the inaccuracies and subjective aspects that human interfaces introduce into the process. [Ref. 9] Each FT-IR is capable of processing a maximum of 2 samples per-minute or up to 48,000 samples annually. [Ref. 20] Although this is a type of spectrometer, it does not have the ability to determine wear metal concentrations as does the A/E Spectrometer. [Ref. 9] The FT-IR does have the ability to corroborate the finding of abnormal levels of particulates. [Ref. 10]

The FT-IR sends an infrared beam of light through an oil sample and a series of colors are displayed on the test instrument. The test instrument itself interprets those colors and determines quantitatively the presence of water, soot, fuel, coolant, oxidation, nitration, and sulfate as well as other physical aspects of the sample. [Ref. 9] In total, 17 aspects of the sample are derived from one reading by the FT-IR. There are a total of 33 aspects that could be gathered from this one reading. As of yet, no program management office has determined that those additional 16 aspects would assist with the diagnostics of a system. [Ref. 20]

Based on the spectrometric and physical test findings, the laboratory will make recommendations. These recommendations are based on guidelines, which are established for specific EIMODs or components used for several EIMODs. [Ref. 4: p. 4-5] (See Appendix G for an example of specific ranges). These recommendations are also based on trends. Trends involve comparisons with previous samples. Graphing a series of sample test results over time can show both increasing and decreasing trends in contaminate levels or other oil characteristics that will cause the lab to make a specific recommendation. [Ref. 9] These recommendations can range from “continue normal sampling”, to “resample because contamination is suspected”, to “change the oil and filter.” [Ref. 4: p. G-3 through G-6] (See Appendix E and F for the complete list of recommendations and corresponding codes). If the sample analysis results in an erratic increase or decrease in the trend, the lab recommends a resample. [Ref. 5: p. 2-4] In most cases, if there is any indication that there is something unusual, a resample is requested before recommending changing components. This results in a resample before almost any component is replaced. [Ref. 10]

As stated above, these recommendations include several different laboratory recommendations. These could potentially contradict one another. The unit is to follow the worst case recommendation. If the lab spectrometric results indicate that everything is normal, the viscosity test recommends a resample, and the flash test determines that the oil should be changed; the unit should change the oil. [Ref. 9] Regardless of the lab’s recommendation, including a recommendation not to operate the equipment, the decision

to deadline (designate non-mission capable maintenance) remains with the unit commander. [Ref. 14: p. 39]

## **E. LABORATORY REQUIREMENTS**

### **1. Personnel**

The lab operations at Fort Hood are contracted to a civilian contractor with a Fixed Price type contract. Therefore, the risk of having the appropriate number of personnel on site is born by the contractor. However, the contractor would generally use the same estimating procedures in developing an organization plan, [Ref. 10] so the generalities of the personnel requirements will be discussed. The lab can use one estimate based on spectrometric testing alone or another based on both spectrometric and physical. [Ref. 4]

Based on spectrometric testing only, the personnel requirements of an oil analysis lab vary based on two factors; the workload expected and process used (manual or automated). [Ref. 4: p. 2-1] The automated lab will be described in this thesis because the Fort Hood lab is automated. [Ref. 9] Both of the factors are used in one equation where  $P=W/1100$ . In this equation P is the number of personnel required and W is the estimated workload in samples per-month. [Ref. 4: p. 2-1] For an example, a 10,000 sample workload would result in a personnel estimate of 9.09. This value would be rounded up to the next highest number, which in this case is ten technicians.

The alternate means of determining the number of lab personnel required to process samples is based on conducting both spectrometric and physical sample testing. Generally, each full-time technician can perform 800 analyses per-month for automated labs. [Ref. 4: p. 4-1] Using the same assumptions as for the previous estimate, the 800 is divided into the maximum number samples and rounded up to the nearest whole number, which results in an estimate of 13 technicians. Due to the introduction of the FT-IR, the spectrometric estimation more closely approximates actual lab manning. [Ref. 10]

In addition to the personnel required to analyze the samples, there is also a requirement for Army labs to have a certified evaluator present at all times. The lab must employ two certified evaluators full-time. [Ref. 4: p. 2-1] Having two full-time evaluators allows the lab to operate throughout the normal workday while each evaluator takes breaks or lunches. It also allows the evaluators to take leaves throughout the year without shutting the lab down. [Ref. 9] This would bring the total estimated personnel requirements for the Fort Hood lab to 15.

Lastly, there are requirements for data transcribers/lab aids and both administrative and housecleaning personnel. The data transcribers perform the tasks of in processing samples and maintaining the monthly reports. A lab processing 70,000 samples per-year would require two people to perform these tasks. Although no set requirements are established for administration and housekeeping, these are important duties to ensure the proper functioning of the lab. [Ref. 20]

## 2. Quality

### a. *Evaluator Certification*

In addition to personnel requirements, there are also training and other requirements to ensure the quality of sample analysis. Each person working as either an operator or evaluator must meet certain training requirements to perform their duties.

[Ref. 4: p. 4-1]

Both operators and evaluators must meet the same basic training qualifications. Both must complete the DOD Operator/Evaluator Training Course followed by 30 days of on-the-job training in an AOAP certified lab. The final requirement is to gain an additional five months of operator experience. There may be times when it is not feasible for operators or evaluators to satisfy all of these requirements; therefore, there is the potential for the AOAP Program Manager (PM) to grant a waiver. [Ref. 3: p. 4-6]

The evaluators must meet several additional criteria. They must be adept in performing all laboratory tests and have a minimum of 12 months experience. This experience must include a minimum of six months operating the spectrometer and four months performing physical tests (may be concurrent). It must also include a minimum of six months of on-the-job training as an evaluator with a certified AOAP evaluator. This on-the-job training can not be concurrent with the testing experience. The individual seeking certification can request a waiver on the length of training if they have earned experience elsewhere analyzing oil samples. Under these conditions, a minimum of three

months training in an AOAP lab is required, but the length and training required will be based on qualifications provided in the written request for waiver. Lastly, the potential evaluator must pass both a written and performance test. Because the Fort Hood lab performs tests for both aeronautical and non-aeronautical samples, an evaluator in that lab must be certified for both. They must pass the written and performance tests as well as meet testing familiarity requirements for both. [Ref. 4: Annex N]

An evaluator can be decertified by a number of methods. These methods include false data entry for samples, disregard for AOAP policies and procedures, or not meeting full-time employment periods. These periods include full-time employment of less than eight consecutive months within a year or not being employed full-time for four consecutive months. [Ref. 4: Annex N]

***b. Certification Program***

The Joint Oil Analysis Program (JOAP) administers the certification for all oil analysis labs. This program ensures standardized procedures and quality assurance among all the Department of Defense (DoD) labs. Participation in this program is mandatory for all labs with A/E Spectrometers. [Ref. 4: p. 3-14] Because the Fort Hood lab is an A/E lab, it is included in this program. [Ref. 9] The certification is based upon lab facilities, personnel qualifications, and correlation program performance. [Ref. 4: p. 3-14]

The facilities requirements include space, equipment, and environmental controls. Space and equipment depend mostly upon the expected number of samples

processed each month and the program manager's determination. [Ref. 4: p. 4-6] The environmental control requires the lab to maintain the facility's air temperature at 75 degrees Fahrenheit plus or minus three degrees and relative humidity to 50 percent or less. [Ref. 4: p. 2-3]

The personnel requirements cover total employment and training. This ensures adequate personnel to maintain proper operations. It also ensures that each of the employees receives the proper training, [Ref. 4: p. 4-6] as stated in the personnel section of this thesis.

The last portion of the certification program is the correlation tests. This is a monthly program where a set of two sample pairs is obtained from the JOAP Technical Support Center (TSC). These samples are developed to ensure precise concentrations of materials. Each sample is tested on each of the labs A/E Spectrometers and results are recorded and sent to the JOAP-TSC. [Ref. 3: p. 4-11] These are submitted for each spectrometer in a standard message format [Ref. 4: p. 3-16] (see Appendix M). When JOAP-TSC compares the known concentrations against the lab's results, they are assessed as either "correct" or "incorrect". [Ref. 9]

The results are scored based on the type of spectrometer. For A/E Spectrometers, each sample pair receives a score of 3.33 per-wear metal correctly analyzed (See Appendix N for sample scoring). [Ref. 3: p. 3-15] The spectrometer must correctly identify the concentrations of wear metals in the samples to within 2% to be assessed as correctly analyzing the sample. [Ref. 9] The total potential score of the two

sample pairs is 100, rounded up the nearest whole percentage point. The results are due into the JOAP-TSC not later than the 22nd of each month. For every workday late, one point is deducted from the score for each spectrometer for a maximum of five points deducted. The results however can be up to a total of 15 days late. After 15 days, the lab is scored as a zero and loses its certification. [Ref. 3: p. 3-15]

To maintain certification, the lab must continue to submit monthly reports. As long as the lab maintains a three-month average of 80% or above, the lab remains certified. [Ref. 4: p. 4-1] This is an average of all the spectrometers within the lab. [Ref. 9] If the lab falls below the 80% three-month average, it loses its certification. [Ref. 4: p. 4-3] When a spectrometer fails to correctly analyze the sample, maintenance is performed on the equipment to determine and correct the cause. [Ref. 9] The difference between correlation and standardization checks is that with the later, the lab knows the concentrations and calibrates the instrument accordingly.

## **F. CHAPTER SUMMARY**

This chapter has provided a basic background of oil analysis to include intents of, processes used in, and requirements of the program. The intents each relate to saving money, increasing readiness, self-improvement of the program, and safety of the soldiers. One main assumption for this thesis is that aeronautical equipment oil analysis is critical for the safety and that, regardless of the cost-benefit ratio, they would not be removed from the program. [Ref. 39]

The processes described covered the entire sequence from the unit identifying the sampling requirements, taking the samples, submitting the samples to the lab, performing the analysis in the lab, reporting the results, and then acting on those reports and recommendations. The tools that support both the unit and lab in executing these processes are discussed, both specific testing equipment and procedures as well as maximum annual testing per-type of test equipment.

Finally, the requirements of personnel and quality controls were discussed. The driving factor in the number of personnel is the maximum number of samples expected per-month. However because the lab is contractor operated, the contractor must weigh the risks of manning against profits and meeting contract requirements.

Each of these topics discussed affects the costs and benefits of the program as a whole. Therefore, they lead directly into the following chapters where each of the specific costs and benefits will be discussed quantitatively.

THIS PAGE INTENTIONALLY LEFT BLANK

### III. COSTS OF AOAP

#### A. CHAPTER PURPOSE AND INTRODUCTION

This chapter compiles oil sampling costs. Due to safety concerns for aeronautical equipment and their associated personnel, this thesis assumes that the AOAP program would remain in effect regardless of the cost-benefit relationship. Therefore, any fixed or other cost attributed to maintaining aeronautical equipment on the program will not be factored into the costs for ground systems.

Although there are many factors that allow for monetary quantification, others do not. Those not quantifiable will be identified to ensure their impacts are considered. In addition, there are perceived costs that require discussion.

This thesis uses Enlisted Grade four (E-4) "all Army" for all tasks that cannot be directly linked to a specific Military Occupational Specialty (MOS) or person. Their annual costs are life cycle costs of bringing soldiers into the force and maintaining them. These include Military Personnel Appropriations (MPA); Operations and Maintenance, Army (OMA); and procurement costs for pay, allowances, training and initial clothing issue. [Ref. 24: p. 109] Each military and civilian cost is obtained from the Army Military Civilian Cost System (AMCOS) 98 Program, used by the United States (U.S.) Army's Cost and Economic Analysis Center (CEAC) for cost-benefit analyses. Year 2000 costs are used, which may cause personnel costs to have a slightly increased impact on the outcome. During the sensitivity analysis, this impact will be weighed. In addition,

each soldier is estimated to work 50 hours per-week, 52 weeks a year; totaling 2,600 hours per-year. [Ref. 13]

Many of the costs are directly related to the number of systems that the lab supports and the analysis results of those samples processed. Therefore, much of the data in this chapter is based on the actual Fort Hood database of samples processed with corresponding recommendations.

## **B. SUPPORTED EQUIPMENT POPULATION**

### **1. Categorizing Samples**

The first task was to categorize the potential systems using the Fort Hood lab. This facilitates processing the data in the cost-benefit analysis without compromising data integrity. Each of the systems falling into a specific category will have similarities across the type of samples taken, type and quantity of oils used, and type and cost of filters used. The following categories were established:

1. Heavy Armor (HA) – Generally anything larger than an M113 Armored Personnel Carrier (APC).
2. Light Armor (LA) – Approximate size of an M113 APC.
3. Heavy Construction (HC) – Rated capacity greater than 6000#.
4. Light Construction (LC) – Rated capacity equal to or less than 6000#.
5. Light Tactical Vehicle (LTV) – Smaller than 2 ½ ton.
6. Medium Tactical Vehicle (MTV) – 2 ½ ton and 5 ton.
7. Heavy Tactical Vehicle (HTV) – Larger than 5 ton.
8. Small Generator (SG) – Less than 30KW.
9. Medium Generator (MG) – 30KW and 60 kW.
10. Large Generator (LG) – Larger than 60 kW.
11. M1 – All M1 variants.
12. Other – O (for non-ground systems).

All EIMODs extracted from the AOAP sample databases were categorized. The first step was to cross-reference the EIMODs with other systems components from Table 4-1 Combat Vehicles, Table 4-2 Tactical Wheeled Vehicles, Table 4-4 Watercraft, Table 4-5 Material Handling Equipment, Table 4-6 Construction Equipment, and Table 4-7 Support Equipment-Generators of Department of the Army Pamphlet (DA PAM) 738-750. For example, all systems with the M113 engine (6V53) and transmission (TX100-1) [Ref. 2] were classified into the LA category. If the EIMOD could not be categorized based on one of the tables above, Table E-2 Identification of Required Forms for Combat/Tactical Vehicles and Support Equipment or DA PAM 738-750 was referenced for categorization.

In the event these tables were not sufficient for classification, the Logistic Support Agency (LOGSA) web site for Technical Manuals (TMs) was referenced for either appropriate TMs or Lube Orders (LOs). After a detailed search of the LOGSA web site, there still remained EIMODs that were not categorized. The next step was to cross-reference the component models listed in the AOAP sample database with those systems already classified. After this step, almost all of the EIMODs were classified.

The remaining EIMODs were classified according to recommendations from Lieutenant Colonel (LTC) Brad Naegle, based on his previous knowledge of Army systems. LTC Naegle is an Army officer with over 23 years on Active duty service. He completed both the Basic and Advanced Armament Maintenance Officer Courses. He has served as both Chief of the Division Material Management Center for a heavy division and Commander of a DS maintenance company for a heavy division. He has

additionally executed duties as the PM of the Tactical Wheel Vehicle (TWV) Remanufacturing Program and the Deputy Program Executive Officer (PEO) for TWV.

## **2. Population Determination**

### ***a. Percentage of Non-Ground Systems***

The ground systems population using the Fort Hood facility was determined from the lab's sample results database. A spreadsheet depicting the following process is attached in Appendix L. An excerpt from this spreadsheet is shown below in Tables 3.1a and 3.1b. The AOAP Program Management Office (PMO) provided an initial database, which included only EIMOD, sample date, and recommendations. The third column, which is titled "Initial Database" is the total number of samples with that EIMOD provided in the initial database. This information was used to determine what percentages of the samples processed were from non-ground systems. Non-ground systems included aircraft, locomotives, and other systems that were not identifiable, but were in such small numbers, they do not impact the data. The total non-ground system samples were 4,315 out of a total of 93,338 samples for Calendar Year (CY) 1999, which is 4.62%.

As established in the previous chapter, even if ground systems were eliminated from the AOAP program, the lab would still process aeronautical samples. This would cause the lab to continue to execute the monthly and daily standardization samples. In total, the lab performed 5,419 standardization samples during Fiscal Year (FY) 1999. [Ref. 10] Although the database used covers CY 1999 and other data is based on FY 1999, both cover one-year periods with three of the quarters being identical.

Therefore, the use and comparison of data between these two time periods has little impact on the overall results.

<u>EIMOD</u>	<u>CAT</u>	<u>Initial Database</u>	<u>Second Database</u>	<u>EIMODs With Duplicates</u>	<u>Total Duplicates</u>	<u>Short Duration Usage</u>
M10A	HC	377	377	45	377	0
M992A2	HTV	1154	1154	91	1154	0

**Table 3.1 a. Determining Population**

<u>EIMOD</u>	<u>Total Systems</u>	<u>Jan Thru Jun</u>	<u>Jul Thru Dec</u>	<u>UNINSTALLED</u>	<u>1 YR</u>	<u>1/2 YR</u>	<u>1/4 YR</u>
M10A	45	36	41	0	36	5	4
M992A2	91	90	84	0	84	6	1

**Table 3.1 b. Determining Population**

The lab needs to analyze a minimum number of standardization samples to support non-ground systems. This minimum includes two samples per-day for five days a week, 52 weeks per-year, for a total of 520 samples per A/E Spectrometer. This addresses the requirement for checking accuracy of the instruments at the beginning of each day and again in the afternoon. An added four correlation samples each month for 12 months for each A/E Spectrometer would support the lab's certification process. [Ref. 10] Based on Fort Hood operating two spectrometers, [Ref. 20] the total estimated standardization and correlation samples would be 1,136. Adding this to the number of aeronautical samples from the initial database results in 5,451 attributed to non-ground systems. Dividing the non-ground system samples by the sum of total system, standardization, and correlation samples result in 5.59% of the samples being attributed to non-ground systems. This percentage will be used in later determining the costs associated with non-ground systems.

*b. Determination of Ground System Populations*

Referring back to Tables 3.1 a and b, each of the EIMODs was placed into categories abbreviated as "CAT." These categories are listed in the previous section of this thesis titled "Categorizing Samples." The two represented below stand for Heavy Construction (HC) and Heavy Tactical Vehicle (HTV).

After the percentage of non-ground systems was determined, the AOAP PMO provided a second database with more complete information. This database did not include non-ground systems, but included laboratory recommendations, dates, EIMOD serial numbers, component nomenclature, and component serial numbers. This database was provided in two portions. The first included all samples from January through June of 1999. The second included samples from July through December 1999. These two databases were used to determine the population of systems using the lab through a series of calculations.

First, consideration was given to variances between the two databases. The largest absolute quantity difference involved Light Tactical Vehicles (LTV), which differed by 171 samples between the two data sets, a 0.9% difference. The largest percentage difference involved the Small Generator (SG) category, which varied by approximately 4%, or 53 samples. These differences are insignificant relative to the total number of samples. In aggregate, there is only 0.77% difference, so there is little chance that variations will skew the results of this analysis.

The value recorded in the column titled "Second Database" is the total number of samples that were listed by EIMOD from the second database. This represents

all the samples including engine, hydraulic system, and transmission. The spreadsheet was then consolidated by EIMOD and transferred into Microsoft Access to determine the number of duplicates. This duplicate count was based on EIMOD and serial number, because no two pieces of equipment should have the same end item serial number. The number of EIMODs with duplicate samples was determined and then listed under the column title "EIMODs with Duplicates." The number of duplicate samples for each EIMOD was then summed in the column titled "Total EIMOD Duplicates."

This permitted an assessment of the number of systems that did not have more than one sample in the database and only utilized the Fort Hood lab for a short period of time. This was determined by subtracting the "Total EIMOD Duplicates" column from the "Second Database" column and then recording the resultant in the column titled "Short Duration Usage." For the two EIMODs depicted in Tables 3.1 a and b, all the samples were accounted for in the duplicate counting. Therefore, there are no systems from these EIMODs that had only one sample in the database.

Using this information, the total number of systems under that EIMOD can be calculated by adding the "EIMODs with Duplicates" and "Short Duration Usage" columns. By adding the systems with unique serial numbers (EIMODs with one sample) and systems that have multiple samples, the maximum number of systems utilizing the Fort Hood laboratory can be determined. This result is recorded in the column titled "Total Systems".

The next step was to determine if the systems used the lab for the entire year, or just a portion of the year. This accounts for reserve component units training on

Fort Hood, and avoids artificially increasing the number of systems permanently on Fort Hood. The database was again transferred into Microsoft Access. It was separated into the two half year files. The number of duplicates by EIMOD and serial number was calculated again. The results for the first and second halves of the year were recorded in the column titled "Jan thru Jun" and "Jul thru Dec" respectively.

Then, the samples listed under the EIMOD UNINSTALLED had to be added into the count. These samples represent components of systems used for training at Fort Hood. An example is a 2 ½ Ton truck engine that is on a fixed stand to instruct students on maintenance tasks. [Ref. 13] When samples are taken and sent to the lab, they are listed as UNINSTALLED for its EIMOD. UNINSTALLED samples were grouped by component and then counted. Duplicate serial numbered samples were identified and then subtracted to determine the total number of unique assets. The samples were classified by the component number to an EIMOD by comparing the component model and component models of other EIMODs in the database. If there were transmission and engine samples linked to the same EIMOD from the UNINSTALLED samples, the larger of the two numbers was used to estimate the quantity of systems that the samples represented. These values were then recorded in the column titled "UNINSTALLED."

After calculating these quantities, the systems were placed into one of three categories: systems using the lab those for the entire year, those using the lab for approximately half the year, and those using the lab for approximately one quarter of the year. The two half year duplicates listed under "Jan thru Jun" and "Jul thru Dec" were

compared, using the lower of the two numbers as the quantity using the lab for the entire year. This was recorded in the column titled "1 YR." The difference between the two quantities as the number of systems using the lab for half the year and recorded in the column titled "1/2 YR." The quantity of systems using the lab's resources for only a quarter of the year was determined by subtracting the two previous quantities from the value in column "Total Systems" and then adding the value from "UNINSTALLED." The results of the above process is an estimate of the total number of systems utilizing the Fort Hood lab for 1 year, 1/2 year, and 1/4 year respectively, (shown in Table 3.2) for use later in the cost-benefit analysis.

The next step is to determine the number of equivalent systems using the lab. Taking the number of systems using the lab for various periods of time, the equivalent number of systems is each time period's number multiplied by its fraction of a year and sums the results. For HA, the number of systems are 1,025, 291, and 243 for periods of one, one-half, and one-quarter years respectively. This results in a total of 1,231.25 equivalent HA systems. Executing this same calculation for all categories results in 12,609.25 systems.

<u>CAT</u>	<u>1 YR</u>	<u>1/2 YR</u>	<u>1/4 YR</u>	<u>Equivalent Systems</u>
HA	1025	291	243	1231.25
LA	1360	299	473	1627.75
HC	115	30	19	134.75
LC	165	28	49	191.25
LTV	2691	617	2668	3666.5
MTV	2751	482	674	3160.5
HTV	1215	208	519	1448.75
SG	176	83	159	257.25
MG	132	62	118	192.5
LG	16	11	5	22.75
M1	583	111	150	676

**Table 3.2. Population on Fort Hood**

The use of equivalent systems gives each system the same weighting of the population. This is not precisely accurate, but it is a good basis for comparisons later.

*c. Representative Systems*

After determining the population of equipment, representative systems were chosen for later use in both costs and benefits. Systems with the most samples processed were used to represent that category of systems. This is depicted in Table 3.3.

<u>CATEGORY</u>	<u>REPRESENTATIVE SYSTEM</u>
HA	M2 (Bradley)
LA	M113 (APC)
HC	M10A (10,000 # forklift)
LC	M4K (4000# forklift)
LTV	M998 (1 ¼ ton truck)
MTV	M923 (5 ton truck)
HTV	M978 (10 ton truck)
SG	PU 798 / MEP 803A (10KW Generator)
MG	PU 406 B/M / MEP 005A (30 KW Generator)
LG	PU 495 B/G / MEP 007B (100 KW Generator)
M1	M1A1 (Abrams)

**Table 3.3. Representative Systems**

Some grouped systems vary in aspects such as quantity of oil, cost of filters, and components sampled. In total, these variations have minimal effect on the outcome of the data. Based on the large number of systems and samples, the variations offset to minimize their impacts.

### **C. COST OF CONTRACTOR**

The Fort Hood AOAP lab operations is outsourced using a Fixed Price (FP) type contract. The Government pays the contractor to receive, test, and report on the samples delivered by any unit assigned or training on Fort hood. The Government supplies all test equipment, maintenance (above operator level), chemicals, facilities, utilities, and waste removal. The contractor is compensated solely for his estimated personnel costs with an estimated profit. [Ref. 10] As stated in the previous chapter, the personnel manning is partly a fixed cost due to minimum operating parameters and partly a variable cost based on the number of samples estimated.

The contract includes both the AOAP lab and the fuel lab operations. The price paid to the contractor for this effort is \$365,000. The fuel lab is a smaller operation with only 3,986 fuel samples during FY 1999. Because both oil and fuel samples require equivalent effort to process, [Ref. 10] the percentage of the total samples is used to allocate costs in this thesis. Dividing the fuel samples by the total number of samples processed in both labs during FY 1999 (109,561) [Ref. 10] results in 3.6%. The portion associated with the AOAP lab is \$351,860. Although the number of samples processed

differ between CY 1999 and FY 1999, the use of common FY 1999 data for oil and fuel samples is valid for a ratio over a year period.

An estimated 40% of the remaining costs are fixed costs of operating the oil lab. [Ref. 10] The remaining \$211,116 is variable based on the number of samples. [Ref. 10] Using the same percentage for non-ground systems results in \$199,315 applicable to ground systems oil analysis.

Because this is a FP type contract, the actual number of samples processed does not affect the cost to the Government within this year. As volume increases or decreases, the cost remains the same, however, these increases or decreases may have effects on the future years cost estimates of the contractor and ultimately affect price. These increases or decreases do have an affect on the per-system cost with the present cost being \$15.81.

#### **D. GOVERNMENT COST OF CONTRACT**

In addition to the direct contract costs, there are costs associated with Government supervision of the labs. Both a Contracting Officer's Representative (COR) and Installation Monitor are used for this effort. The COR on Fort Hood is a civilian General Services (GS) grade 9. He spends 0.25 Man-Years (MY) supervising both labs. The Installation Monitor is a Chief Warrant Officer (CWO) 4, who spends 0.1 MY in supervision. [Ref. 10] Annual costs were estimated at \$52,725.73 and \$115,894.48, respectively. [Ref. 23] Approximately 2/3<sup>rd</sup> of each person's effort is towards the oil lab [Ref. 10], resulting in costs of \$4,393.81 for the GS9 and \$3,863.15 for the CWO4. An additional estimate that eliminating ground systems from the AOAP program would have

little to no effect on the time spent by each [Ref. 10] results in no additional indirect costs associated to the ground systems.

Contract modifications add to the cost of the contract. There were three contract modifications during FY 1999. Each of these modifications reflected Congressional Continuing Resolutions (CR). For each, there is an approximated cost of \$500 for a total of \$1,500. This cost would have been incurred regardless of any ground system's participation in the AOAP Program [Ref. 10] and therefore would not be associated with those costs. The costs would also have been incurred if only the fuel lab was included in the contract. [Ref. 10] Therefore, no costs are associated with the oil lab.

Another aspect of supervision is the management costs of both the AOAP and JOAP PMOs. There are some supervisory tasks for procuring test instruments and processing paperwork that the PMO must accomplish for Fort Hood lab. [Ref. 9] However, these costs are marginal and must be accomplished for the program as a whole. These same tasks would be required if the program involved only aeronautical systems. [Ref. 9] One could argue that, if eliminating ground systems from the program reduces the quantity of samples, then labs could be consolidated and reduce the manning requirements of the program offices or that PMOs could be consolidated throughout DoD. However, because aeronautical systems are not allowed to fly until results of sampling are known, a cost-benefit analysis would be required to determine the trade-offs of consolidating labs. Both of these are outside the scope of this thesis. Any additional costs that might be incurred are minimal and have no significant affect on the outcome of this analysis; they are excluded from further inclusion in the cost-benefit analysis.

## E. LAB MATERIALS

Both labs use chemicals and supplies to process samples. The chemicals are used in testing the samples, as with the Ferrographic Analyzer, and in cleaning equipment after testing is complete. The total chemical cost for FY 1999 was \$13,990. Supplies include paper towels, ferrogram slides, paper, beakers, and other materials used for testing and cleaning. A total of \$74,000 was spent for supplies in FY 1999. The amounts used for each of these categories are directly related to the number of samples processed. [Ref. 10] Applying the same 3.6% of total effort towards the fuel lab results in \$13,486 for chemicals and \$71,336 for supplies being applied to the oil lab.

To determine the portions applicable to ground systems, the 5.59% for non-ground systems must be subtracted out. This yields \$12,732 for chemicals and \$67,348 for supplies.

There is an additional cost of chemicals and supplies in that they become waste. The amount of material disposed of is completely dependent on the number of samples processed. [Ref. 10] There were seven 55-gallon drums disposed of during 1999, with each drum weighing an average 550 pounds and costing \$0.35 per-pound. [Ref. 12] Although there is additional solid waste from items such as paper towels, [Ref. 10] no reference could be found with information on this cost. Because Fort Hood is a large installation with many dumpsters to empty, the cost of emptying one additional dumpster is miniscule and can be considered a non-cost to oil sampling. This leaves the total cost of waste disposal at \$1,348. Factoring out the costs associated with non-ground systems yields a cost of \$1,273 for ground systems.

If the volume of ground system samples increased or decreased, these costs would change in direct proportion. These changes per-system can be determined by dividing these costs by the total equivalent systems. This results in \$1.01, \$5.34, and \$0.10 per-sample for chemicals, supplies, and waste respectively.

## **F. OVERHEAD**

There are five components included in overhead costs. These are utilities, facilities, miscellaneous, [Ref. 10] training, and maintenance. [Ref. 13]

The utilities have both fixed and variable aspects and cost a total of \$6,528 for the oil lab alone. Because environmental controls, test equipment, lights, and computers remain on throughout the day, approximately 30% of the cost is fixed. The remainder of the costs vary with the number of samples processed. [Ref. 10] Factoring out the fixed costs and the variable costs associated with non-ground systems results in \$4,314 applicable to ground systems.

The facilities cost of the oil lab totaled \$3,044 for FY 1999. This cost is a fixed cost and does not depend on sampling or other variables. [Ref. 10] Because this facility would still be required if only non-ground systems participated in oil analysis, [Ref. 10] none of this cost is associated with ground systems.

Miscellaneous costs are those replacements required for computers and other equipment within the lab and were estimated as variable based on the number of samples. These costs totaled \$3,178 for FY 1999. [Ref. 10] Excluding the percentage of non-ground systems results in \$3,000 for ground systems.

The training costs are functions of the new personnel and new equipment training. During FY 1999, there were no new personnel, but there were new FT-IRs purchased. Both evaluators at the lab required training on the new FT-IRs, which resulted in a cost of \$1,875. The training costs and requirements would have been identical had the lab processed only non-ground systems samples. [Ref. 10] Therefore, no cost is associated with ground systems.

Maintenance costs are incurred whenever spectrometers are either non-operational or do not correctly analyze correlation samples. For FY 1999, \$6,292 was spent for these tasks. Because equipment usage directly affects the amount of maintenance required, these costs are entirely variable. [Ref. 10] Applying the percentage for ground system samples results in \$5,940 applicable.

As with material costs, both miscellaneous and maintenance costs would have increased or decreased as ground samples did. The cost per-system was \$0.34, \$0.24, and \$0.47 per-system for utilities, miscellaneous, and maintenance, respectively.

## **G. EQUIPMENT COSTS**

The costs of all Automated Data Processing (ADP) equipment (such as OASIS), telephones, and other required tools to perform oil analysis and report results are fixed. If the lab analyzed only non-ground systems, the costs would be the same and are not considered in this thesis. The test equipment however, is part fixed and part variable relative to ground systems. [Ref. 10]

There are a total of six test instruments on Fort Hood, two are A/E Spectrometers, three are FT-IRs, and one Ferrographic System. [Ref. 9] The costs to purchase each instrument during FY 1999 were \$48,000, [Ref. 20] \$52,000, and \$65,319, respectively. [Ref. 10] Based on the number of aeronautical samples processed, testing requirements, and maximum testing capabilities of each instrument, one of each type instrument is required to meet the oil lab's aeronautical workload. The remaining three instruments are costs associated with ground systems and amount to \$152,000.

To determine the annual cost of these instruments, they must be discounted over their operational lives. Seven years is the standard period used for this type equipment. [Ref. 20] A constant dollar discount rate of 4% is applied. [Ref. 35] Using a future series of end-of-month payments to recover this present sum investment will result in the annualized cost. [Ref. 36] The equation used is  $A=P[(i(1+i)^n)/((1+i)^n-1)]$ , where A is the annual cost, P is the present investment, i is the discount rate, and n is the number of years. [Ref. 36] Applying this equation to this set of data results in \$25,325 per-year cost for test instruments. Each of the test instruments was assigned a zero salvage value. [Ref. 24: p. 40] As such, no reduction was made to this cost.

As with all military equipment, test instruments are usually maintained for much longer than their pre-determined operational lives. [Ref. 13] In fact, the average actual length of operational life for AOAP test instruments is 14 years. [Ref. 20] Using this increased operational life would reduce the annual cost of test equipment.

The test instrument costs depend on the quantity of items purchased at any one time. [Ref. 20] If the AOAP PMO coordinates multiple purchases into one or coordinates with other DoD oil analysis offices, the cost per-item decreases. [Ref. 20]

The cost per-system for test instruments is \$2.01 per-sample. However, unlike other costs, the cost per-sample changes as more or less samples are processed. Once the instruments are purchased, they possess the ability to process a number of samples. As long as the number of samples does not exceed the processing ability (144,000), the cost of test instruments does not change.

## **H. SAMPLING COSTS**

### **1. Personnel**

There are several costs associated with sampling, which include personnel, sampling containers, oils, and filters. The personnel costs include the leaders supervising, clerks processing, and operators drawing the samples. Supervisors spend approximately the same amount for either oil analysis or set interval oil changes. [Ref. 13] Based on this, no supervisor costs are associated with oil analysis.

Regardless of oil analysis or set interval oil changes, the ULLS clerks spend roughly the same amount of time processing paperwork. However, for oil analysis, each company level clerk delivers samples to the lab each week. [Ref. 13] To determine the number of unit clerks executing these tasks each week, a count of units was made from the Fort Hood Telephone Directory. This totaled 293 units. [Ref. 22] Each unit clerk is estimated to bring samples to the lab each week for 52 weeks. Each trip requires the

clerk to spend approximately 0.5 hours travelling and in-processing samples at the lab. [Ref. 13] These estimates result in 7,618 hours of effort. This number has both under and overestimating aspects. It underestimates because it does not consider the number of units temporarily training on the installation. It overestimates because not all of those units turn in samples every week. In fact, some clerks save time by coordinating trips with other company level clerks. [Ref. 13] These two factors help offset one another. The E-4 "all Army" cost (\$49,792.14) [Ref. 23] is used because units can utilize other MOSs within their unit to deliver samples to the lab. [Ref. 13] The resultant total cost is of \$145,891 per-year.

Additional costs are associated with system operators gathering samples. This time includes receiving the containers, taking the sample, and cleaning up. [Ref. 13] This process takes each operator 18 minutes or 0.3 hours per-sample. [ref 17] Estimates of this time range from 5 [Ref. 14: p. 38] to 30 [Ref. 13] minutes per-sample. "All Army" E-4 is used for this cost because of the diversified group of MOSs gathering samples. To determine the total time gathering samples, the number of ground system samples obtained from the CY 1999 "Second Database" (89,705) is multiplied by the time to sample, resulting in 26,911.5 hours. At a \$49,792.14 annual labor cost, [Ref. 23] this results in a total cost of \$515,377.

The total personnel costs were \$661,268. The per-system cost is \$52.44. As with the test instrument cost, only the personnel sampling costs vary with the number of systems. This is because the clerks must invest this time regardless of the number of samples they bring to the lab.

## 2. Material Costs

The material costs of sampling include both containers and oils. Containers (National Stock Number (NSN) 8125-01-082-9697) [Ref. 14: p.31] are ordered at \$52.67 per-box of 120 for a cost of \$0.44 each. [Ref. 25] Because the lab recycles 75% of the containers, [Ref. 10] the total applicable cost for CY 1999 was \$9,868.

For each sample, six ounces of oil is extracted from the system. The oil costs are different for each category and component of ground system and are listed in Table 3.4 with type oil and cost. The types of oils used were obtained from logisticians in the PMOs of the representative system. Units will typically use the most economical size containers to replace oils. [Ref. 13] A search of the Defense Logistic Agency's (DLA) Electronic Mall determined the oil costs. Although units are directed to use recycled oils when available, [Ref. 33] the lowest cost oils chosen regardless. The costs were then converted to the cost of 55-gallons.

<u>Category</u>	<u>Component</u>	<u>Total Samples</u>	<u>Oil Type (OE/HDO)</u>	<u>Oil Cost [Ref. 25] (55-gal)</u>
HA	Transmission (T)	5,723	15W40 [Ref. 29]	\$129.25
	Engine (E)	5,591	15W40 [Ref. 29]	\$129.25
LA	T	6,346	15W40 [Ref. 33]	\$129.25
	E	7,251	15W40 [Ref. 33]	\$129.25
HC	T	537	10 [Ref. 32]	\$147.44
	E	518	30 [Ref. 32]	\$156.53
	Hydraulic System (HS)	171	10 [Ref. 32]	\$147.44
LC	T	572	10 [Ref. 32]	\$147.44
	E	719	30 [Ref. 32]	\$156.53
	HS	211	10 [Ref. 32]	\$147.44
LTV	T	6,731	Dexron II/III [Ref. 26]	\$180.07
	E	11,333	30 [Ref. 26]	\$156.53
MTV	T	9,736	15W40 [Ref. 34]	\$129.25
	E	13,017	15W40 [Ref. 34]	\$129.25
HTV	T	4,486	10 [Ref. 27]	\$147.44
	E	5,405	15W40 [Ref. 27]	\$129.25
	HS	1,839	10 [Ref. 27]	\$147.44
SG	E	1,346	15W40 [Ref. 31]	\$129.25
MG	E	958	15W40 [Ref. 31]	\$129.25
LG	E	127	15W40 [Ref. 31]	\$129.25
M1	T	2,219	30 [Ref. 28]	\$156.53
	E	2,682	MIL-L-23699 [Ref. 28]	\$656.15
	HS	753	FRH [Ref. 28]	\$600.40

**Table 3.4. Number of Samples and Oil Costs**

The total number of samples listed in Table 3.4 is 88,271. This is 1,434 less than the total number of ground system samples processed based on the "Second Database." These 1,434 samples are hydraulic samples from categories of ground systems whose representative system does not sample hydraulic systems. For these samples, OE/HDO 10 is used as an estimate based on the other hydraulic system's oils.

Using this information, the cost of sampling is determined by multiplying the cost of oil, number of samples, ounces taken per-sample, and a conversion factor of 0.0001413 (converts 55 gallons into ounces). Using HA engine samples as an example,

yields:  $5,591 \times \$129.25 \times 6 \times 0.0001413 = \$612.65$ . Summing the totals for each yields a total cost of \$12,103.25.

This cost is reduced by the amount Fort Hood is paid for waste oil. Regardless of oil type, Fort Hood is reimbursed \$0.07 per-gallon. [Ref. 12] Multiplying the three ounces of oil recycled per-sample, number of samples, conversion factor, and reimbursement rates results in \$3 being subtracted from the cost of sampling.

Totaling these costs results in \$21,974 with \$1.74 per-system costs. So long as the number of samples per-system is constant as the number of systems change, this per-system cost will vary directly with the number of systems.

## **I. COST OF RECOMMENDATIONS**

Not only are there costs of sampling oil, but there is a cost of changing them based on lab recommendations. Because units only change the oil when the lab instructs them to, these recommendations must be included. [Ref. 10] This determines if the lab's recommendations result in higher costs than under interval oil changes. These costs include oil, filter, and personnel. Table 3.5 depicts the values needed to determine these costs. All data in this table (except # changes) is from the source referenced under "CAT." The data in this table is from the Maintenance Allocation Chart (MAC). MAC is the time associated with one soldier accomplishing the task of changing oil and filter. [Ref. 37: p. B-3]

<u>CAT</u>	<u>Component</u>	<u>Oil Quantity (quarts)</u>	<u>Filter Quantity (QTY)</u>	<u>Filter Cost (each)</u>	<u>MAC (hours)</u>	<u># Changes</u>
HA [Ref. 29]	T	56	1	\$71.00	0.5	196
	E	20	1	\$15.50	0.75	176
LA [Ref. 33]	T	36	1	\$398.76	0.5	59
	E	18	1	\$6.26	0.5	355
HC [Ref. 32]	T	20	1	\$10.12	0.5	17
	E	88	1	\$3.72	0.5	23
	HS	124	1	\$67.27	5	1
LC [Ref. 32]	T	88	1	\$11.15	0.5	32
	E	7	1	\$4.63	0.5	38
	HS	65	1	\$65.38	1	8
LTV [Ref. 26]	T	6	1	\$5.62	1.5	151
	E	8	1	\$2.95	0.5	367
MTV [Ref. 34]	T	32	2	\$23.31	1.5	267
	E	25	1	\$5.17	0.8	242
HTV [Ref. 27]	T	38	1	\$10.12	1	41
	E	30	1	\$4.68	1.4	240
	HS	120	1	\$33.46	2	60
SG [Ref. 31]	E	5.9	1	\$3.00	0.4	65
MG [Ref. 31]	E	15	1	\$3.00	0.4	45
LG [Ref. 31]	E	30	1	\$3.00	0.4	8
M1 [Ref. 28]	T	150	1	\$206.45	0.5	95
	E	25	1	\$80.22	0.5	77
	HS	80	2	\$225.00	0.5	15

**Table 3.5. Recommended Oil Changes**

The number of oil and filter changes was derived by a physical count of samples whose worst case recommendation was to change oil and filter. An E-4, 63W, Wheel Vehicle Repairman, at a cost of \$51,064.67 [Ref. 23] was used as the representative mechanic. [Ref. 23] To determine the cost of each oil change, the following are summed:

1. The quantity of filters times cost of each filter.
2. Oil quantity divided by four, times oil cost divided by 55.
3. Personnel cost divided by 2600, times MAC time.

For the HA transmission, this results in \$113.72 per-change. This cost is multiplied by the total changes resulting in \$22,289.15 for HA transmission oil changes due to oil sampling.

The 1,434 hydraulic samples not included in Table 3.5 are added by using the average of all other, except M1, hydraulic systems in the table. There were a total of 114 recommended changes for these samples, which results in a cost of \$20,152.09. Executing these same calculations for each component and summing the results yields a cost of \$217,275.

The MAC times used may be low for some components and categories of equipment. Although this could skew the results of the analysis, the use of the identical numbers in both the costs and benefits should result with minimal impacts on the final results.

The cost of disposing of the filters after oil changes must be added to this cost. Each drum of crushed filters costs the Army \$22 for disposal. Each drum holds between 100 and 200 crushed filters for a median of 150. [Ref. 12] Based on this data, the cost to dispose of each filter is between \$0.11 and \$0.22 with a median cost of \$0.16 per-filter. This is multiplied by the number of filters changed (2,974) to determine a total cost of \$476.

As with the cost of sampling, the recycled oil revenue must be subtracted out of these costs. A total of 23,477.4 gallons of oil was consumed during changes. At \$0.07 per-gallon, selling the used oil returns \$1,643.

The total cost of recommendations is \$216,108. This equates to \$17.14 per-system costs for 1999. So long as the percentage of change recommendations remains the same as the number of systems change, this value directly changes as the systems change.

**J. COST OF QUALITY**

The cost of quality in the program is the added cost of not analyzing samples correctly. This cost can be from requesting too many resamples, too many oil changes, not identifying a potential failure, or recommending maintenance when none is required. The costs of too many resamples or oil changes are already factored into others costs based on actual lab recommendations.

This thesis uses the lab’s quality, measured by their grades in the certification program, as an estimate of quality. Presently, the Fort Hood lab has maintained the following monthly certification scores listed in Table 3.6, [Ref. 9] which average to 91.75%:

<u>Month</u>	<u>January</u>	<u>February</u>	<u>March</u>	<u>April</u>
Score	93%	93%	91%	90%

**Table 3.6. Certification Scores**

All lab recommendation codes (H, K, L, M, and U) (see Appendix E) and all physical recommendation codes (ER, IA, IC, IF, and IW) (see Appendix F) were counted to determine that 67 maintenance actions were recommended. This provides a number to assess the impact of potential mis-analyses. For illustrative purposes, a cost estimate of \$1,000 is made for each unnecessary maintenance action recommended.

The FT-IR and other test instruments provide the lab with an added check of the A/E Spectrometer's readings. For instance, if the A/E Spectrometer indicates high concentrations of wear metals, the FT-IR can corroborate with an abnormal reading of wear metals. [Ref. 10] This is estimated to decrease the potentially 8.25% incorrect recommendations by 50%, to 4.13%. This is on the same order of magnitude as estimated by the COR (1% to 3%) [Ref. 10] and PM (1%) [Ref. 9].

If the lab mis-analyzes the sample, there will typically be an unusual reading that triggers the lab to request a resample. The process is designed so that unless the analysis follows normal trends in wear metals or there is a significant increase or decrease in the contamination concentrations, the lab recommends a resample before it recommends a change of oil or component. [Ref. 10] This was verified by inspecting 12 of the 67 maintenance recommendations. Of those inspected, nine were preceded by "resample" or "change oil and resample" (See Appendix O), two had only one sample in the database, and only one immediately recommended maintenance. This verified that an unusual reading typically would result in a "resample" before recommending a component inspection. With each sample having a 4.13% probability of incorrect analysis, the system as a whole has only 0.17% probability of mis-analysis. As in the case of three of the inspected recommendations, if there are still unusual trends in the analysis, a "resample" or "oil change" is again requested. This results in 0.007% error.

Based on this error, a total of 0.0047 maintenance recommendations resulted in unnecessary maintenance actions. Although this is not a whole number, its impact represents the long-term effects on cost in this year. This results in a cost of \$5.

Regarding the failures that AOAP did not identify, there is no additional cost. Without AOAP this component would have failed. This cost is not associated with the existence of the program and therefore should not be attributed to the program.

## **K. CHAPTER SUMMARY**

To develop the actual costs associated with oil analysis, equipment and samples were categorized. These categories facilitated developing the populations and percentages of ground systems based on sampling databases.

Most costs associated with oil analysis are identifiable from data adjusting for actual sampling results and the percentage of non-ground system sampled. The appropriate portion of those costs can be allocated to ground systems.

There are inaccuracies introduced by several of the calculations and combinations of different data periods. One such inaccuracy reflects using costs associated with three different periods, FY 1999, CY 1999, and CY 2000. Although inaccuracies are introduced by using these different cost years, the effects are minimal. To identify the true impact of these inaccuracies on the cost-benefit ratio, a sensitivity analysis is performed in Chapter V.

The summation of all the costs associated with ground systems is best depicted in tabular form, shown in Table 3.7. These costs are listed as found in the above chapter.

<u>Cost Item</u>	<u>Sub Item</u>	<u>Cost (negative)</u>	<u>Per-System Cost</u>
Contractor		\$199,315	\$15.81
Government Cost of Contract	Supervision	\$0	
	Modifications	\$0	
Materials	Chemicals	\$12,732	\$1.01
	Supplies	\$67,348	\$5.34
	Waste Disposal	\$1,273	\$0.10
Overhead	Utilities	\$4,314	\$0.34
	Facilities	\$0	
	Miscellaneous	\$3,000	\$0.24
	Training	\$0	
	Maintenance	\$5,940	\$0.47
Equipment		\$25,325	\$2.01
Sampling			
Personnel	Supervision	\$0	
	Clerks	\$145,891	\$11.57
	Operators	\$515,377	\$40.87
Materials	Containers	\$9,868	\$0.78
	Oil	\$12,103	\$0.96
	Oil Recycle Recovery	(\$3)	\$0.00
Recommendations	Changing Oils	\$217,275	\$17.23
	Resample	Previously Included	
	Filter Disposal	\$476	\$0.04
	Oil Recycle Recovery	(\$1,643)	(\$0.13)
Quality		\$5	\$0.00
Total		\$1,218,596	\$96.64

**Table 3.7. Summary of Costs**

Dividing the AOAP cost for CY 1999 by the number of systems results in a \$96.64 cost per-system.

## **IV. BENEFITS OF AOAP**

### **A. CHAPTER PURPOSE AND INTRODUCTION**

The discussion of benefits gained from the AOAP will follow the same principles used in developing the costs. The benefits will especially link to the databases of samples processed and the products of that database, including populations. The cost of items linked to both costs and benefits, such as filters, quantities of oil, and oil costs will not be re-listed. The data that is being used in calculations will be identified by both type and location within this thesis.

Although most costs fall distinctly in either the avoided (benefits) or incurred (costs) categories, some, such as oil changes, are found in both. Another common aspect of both costs and benefits is that there are elements that are non-quantifiable. This is especially true of the benefits.

### **B. ENVIRONMENT**

The alternative to oil analysis is changing oil at set intervals. Whenever oil is handled, there is always a potential for some level of environmental contamination and associated costs for clean up. The more oil spilled, the larger the impacts. This potential for spills results from changing oil and taking oil samples. However, less oil is handled using oil analysis. The amount of oil removed from systems under oil analysis was 428

drums. Under set period oil changes, it would have been 6982 drums (see section G of this chapter). Therefore, oil analysis decreases the probability of any oil spill by 1631%.

The question that must be answered is how much might it cost if a soldier spills oil during handling. Placing an exact number on this is very difficult. First, Texas does not consider oil a hazardous material and thus does not view spills as a significant impact on the environmental. [Ref. 12] Second, as long as procedures are in place on Fort Hood to clean-up spills, the cost of spilling oil is minimized. [Ref. 21]

If oil is spilled on Fort Hood, absorbent material is spread over it, picked-up, and then placed into holding containers. Periodically, this used absorbent material is sent off for recycling. The recycling process removes the oil from the material and returns the clean material back to Fort Hood. This absorbent material costs \$40 per-drum to recycle. Any residual oil remaining on the ground is minimal. However, if this residual is eventually washed away, it should be collected in the oil-water separator device present in each motorpool. [Ref. 12] By incorporating these procedures, the environmental cost of oil handling is considered negligible. [Ref. 21]

Although the costs of changing oils are discussed in a later section, the absorbent material costs will be discussed here, because they are used to minimize impacts on the environment. Every case is going to be different, but for comparisons purposes, we will use a value of one gallon of absorbent material for every 55-gallon drum of oil used.

Based on this, changing oils at set periods would use 6,554 additional gallons of absorbent material. This equates to 119 drums of absorbent material recycle costs being

avoided by oil analysis. The benefit is estimated at \$4,766 by using oil analysis. Calculating on a per-system basis, this is a \$0.38 cost avoidance.

The initial cost of the absorbent material is not considered; it is a sunk cost and the recycled material is returned back to the system. Although there is probably some loss during the entire process, this cost is considered negligible.

### **C. MAINTENANCE**

The benefits from maintenance are the costs avoided in repair and maintenance actions. Fort Hood does not maintain records connecting AOAP recommendations with maintenance results and actions. [Ref. 38] However, by identifying potential failures prior to reaching catastrophic failure, the level and cost of repairs is reduced. [Ref. 38]

First, a Cost Estimating Relationship (CER) must be developed. The best CER would use maintenance action recommendations from the lab. To generate maintenance benefits, maintenance must be avoided. This represents the additional maintenance avoided by early identification of a failure. The only time that additional maintenance is possibly avoided is when the lab recommends maintenance. The cost chapter established that there were 67 maintenance actions recommended during CY 1999.

Another question in determining the correlation between maintenance recommendations and cost avoidance is what is the quality of the recommendations? Within the cost chapter, we established that there is a high probability of maintenance being required when the lab recommends specific actions. Based on both the avoided

actions and the quality of the recommendations, the maintenance recommendations would be a good CER for determining the cost avoidance.

The next step is to associate a benefit to the CER. As there is no data available to determine the savings per-maintenance action identified by AOAP, [Ref. 38] for illustrative purposes, we will use \$5,000, as an average saving of all maintenance actions recommended. It is not as important to see the impact of the \$5,000 as it is to see how sensitive the analysis is to changes in this value. Therefore, the basic cost-benefit relationship uses a value of \$335,000 (67 actions at \$5,000 per-action) for the cost avoided and then conducts sensitivity analysis in the next chapter. The per-system cost avoidance would be \$26.57.

#### **D. READINESS**

AOAP impact to readiness is another benefit that does not lend itself to quantification. The analysis of maintenance actions demonstrates AOAP's ability to identify potential failures before they become serious problems. By identifying maintenance actions in advance of catastrophic failures, there is no requirement for additional resources to recover systems in the field. As most equipment is not operated unless it is preparing for or executing missions, [Ref. 13] so any catastrophic failures would directly impact missions, and therefore readiness. With most missions contributing to training soldiers and most recovery operations detracting from other maintenance actions, there is a direct, yet unquantifiable impact on unit readiness.

These direct relations between failures and both resource use and readiness suggest a CER based on the number of recommendations for maintenance. As with maintenance actions, there is no data available to quantify the impact of avoided failures on readiness. Therefore, we will illustrate the impacts with a value of \$2,000 per-maintenance action recommended. This is not a double counting of benefits, because these benefits represent totally different aspects. Maintenance is the savings in parts and labor costs for fixing the equipment. Readiness is the cost of resources to recover, delays of maintenance on other equipment, and lost training for soldiers. Maintenance and readiness have the same dependencies and both impact the outcome of this thesis. The total estimated cost avoidance for readiness is calculated at \$134,000, or \$10.63 per-system.

#### **E. LEARNING FROM OIL ANALYSIS**

There are two things that can be learned from using oil analysis; how to change system designs to eliminate problems, and criteria to make better recommendations and save funding.

To change designs, there must be communication between the AOAP PMO and the organizations that can influence the designs, in this case, the ground system PMOs. During interviews with PMO logisticians, cases were made for good communications, [Ref. 32] poor communications, [Ref. 33] and no communications. [Ref. 40] The feedback from the AOAP is typically provided to the unit, and the unit is expected to

report recurring problems with the equipment PMO. [Ref. 40] One example of where there is poor communications is with a perceived problem of increased concentrations of tin and cooper in recycled oils. [Ref. 33] As discussed in Chapter III, units are directed to use recycled oils when available. Ground system PMOs perceive that the increased concentrations are detected as abnormal trends by AOAP and result in a "change oil" recommendation even when the oil remains clear. [Ref. 33] The PMO is concerned with AOAP's perceived lack of response in finding a solution to this problem. [Ref. 33] This problem is outside the scope of this thesis, but it identifies an area that requires further research. However, this does suggest that if this problem does exist, the costs incurred by AOAP may be able to be reduced by resolving this issue.

The AOAP PM referenced several examples where AOAP discovered design flaws or user instituted failure factors. These include:

1. Weak rocker arm bushings in the (CUCV) 6.2L engine.
2. Wrong size pistons installed in the 6.2L engine.
3. Inefficient air intake system on the M60 tank.
4. Soldier induced fuel leaks in some 903T series equipped weapon systems. [Ref. 9]
5. Cadmium plated tools chipping, causing oils to turn corrosive.

Each of these identified cases represents the ability of AOAP to provide feedback to PMs for cost saving system changes. However, no cost savings data was available. Although these systems are older, it does not mean that the program is incapable of discovering similar problems in newer systems. The next question to ask is that if AOAP is not identifying potential design problems, then why are few examples available? It is

probable that contractors and PMs are providing more commercially designed systems, which results in better quality products. [Ref. 13]

The communication however, could be improved. The AOAP PMO does not currently plan to collect data on the additional 16 aspects of oil analyzed with the FT-IR until the equipment PMOs request these tests. [Ref. 20] Questioning logisticians from several Tank-automotive & Armaments Command (TACOM) PMOs found that none were aware of this capability or how these aspects could assist them.

The other factor of learning is collecting information to make better decisions. This again is not quantifiable for the scope of this thesis. The capability exists for studies to determine the improvements in the quality and accuracy of AOAP recommendations, but that would require looking back over many years of data.

Based on these discussions, no cost avoidance value is assigned to this aspect of oil analysis. Because little is known regarding potential cost savings, no estimate is provided.

## **F. SAVINGS IN LIVES AND HEALTH**

As with most other AOAP cost avoidances, the savings in human life and injury avoidance are difficult to quantify. However, they must be addressed or the wrong conclusion could be obtained.

The first step is to establish the value of both human life and injuries. Based on a majority of labor market surveys, the implicit value of a human life is between 3 and 7

Million (M) dollars. This is established by using wage premiums of risky jobs to establish the value workers and employers place on the risk to the employee's lives. [Ref. 11: p. 1930] Similarly, the value of injuries was established using wage premiums and job injury risks. Based on multiple studies, "the data for all injuries regardless of severity are clustered in the \$25,000-\$50,000 range". [Ref. 11: p. 1935] Both of these values are in December 1990 dollars [Ref. 11] and will be inflated to 1999 dollars for consistent analysis. The median values of \$5 million per-death and \$37,500 per-injury will be used for further calculations.

Next, the risk of death or injury must be determined. Because the values for death and injury are directly related to the risks, using the mean risks for those studies allows the application of those values to today's job risks. With the vehicle operators encompassing the largest population of soldiers at risk, we will discard mean risks from inapplicable studies such as chemical workers. The average of all applicable mean risks was then determined as 0.00635% and 5.557% for death and injury, respectively [Ref. 11].

As with other benefits, this benefit is related to the 67 identified maintenance action recommendations. These recommendations prevent a catastrophic failure from occurring, and thus avoid vehicles from placing soldiers and by-standers in more dangerous situations. These situations include sudden stops on highways, sudden stops during maneuvers, and thrown shrapnel. Multiplying 67 failures by the average mean risks of death and injury, 0.0042 deaths and 3.72 injuries were statistically avoided during

CY 1999. Applying these two risks to the prevented failures underestimates the actual events prevented. Risks should be particularly high during the event of a component failing. However, this provides a means to quantify the cost savings.

Multiplying these prevented deaths and injuries by the costs per-event will determine the estimated avoided costs of oil analysis. This results in \$21,000 and \$139,500 for deaths and injuries, respectively. A discount rate of 4.0% [Ref. 35] is used to inflate these values over the nine year period, using the equation  $F = Px(1+i)^n$ , where F is the CY 1999 value of life or injury, P is the CY 1990 value, i is the discount rate, and n is the number of years. This results in \$30,277 (\$2.40 per-system) and \$198,722 (\$15.76 per-system) for death and injury, respectively.

Although human life is significantly more costly than injury, the relatively low risk of fatality reduces the relative impact on the analysis. Statistically, Fort Hood could avoid one death every 238 years, based on CY 1999 numbers.

## **G. AVOIDED OIL CHANGES**

The largest known benefit of oil analysis is avoiding changing oils at set intervals. The same oil change data described in the cost chapter is used for this analysis. However, we must determine how often oils would be changed based on set intervals. These set intervals are either hours operated, miles, or time periods since the last change. Both hours and miles are directly based on usage. Time can be monthly (M), quarterly (Q), semi-annually (S), annually (A), or biennially (B). Regardless of usage, the oil is

changed when the time period since the last oil change is reached. Table 4.1 is the additional data needed above that found in Table 3.5 (see Appendix P for consolidated data).

Two estimates of mileage or hours were obtained to ensure the accuracy of the estimate. "Estimate 1" was obtained from the PMO and "Estimate 2" was obtained from the Tank-automotive & Armaments Command's (TACOM) Fleet Planning Office.

<u>CAT</u>	<u>Component</u>	<u>Set Mileage</u>	<u>Set Hours</u>	<u>Set Period</u>	<u>Estimate 1</u>	<u>Estimate 2 [Ref. 30]</u>
HA [Ref. 29]	T	1,500		S	2,500	557
	E	1,500		S	2,500	557
LA [Ref. 33]	T	6,000		A	1,500	
	E	1,500		S	1,500	
HC [Ref. 32]	T		250	Q		
	E		250	M		
	HS		250	S		
LC [Ref. 32]	T		500			
	E		100			
	HS		1000			
LTV [Ref. 26]	T	12,000		B		3,763
	E	3,000		S		3,763
MTV [Ref. 34]	T	24,000		B	1,800	3,327
	E	6,000		Q	1,800	3,327
HTV [Ref. 27]	T	6,000		A		2,688
	E	3,000		S		2,688
	HS	6,000		A		2,688
SG [Ref. 31]	E		300		4,320	
MG [Ref. 31]	E		300		4,320	
LG [Ref. 31]	E		300		4,320	
M1 [Ref. 28]	T			B		522
	E			S		522
	HS			B		522

**Table 4.1. Additional Oil Change Data**

For the LC category, no set periods were established. [Ref. 32] Based on the component similarities with HC, we will use the same periods. In addition, data on the average annual hours for both LC and HC are not recorded. [Ref. 30] We will use the set period as the controlling interval for both LC and HC, considering that all other categories except generators follow this rule.

Based on this information, we can calculate the cost avoidance. For this sequence of calculations, the HA transmission will be used as an example.

The first step is to calculate the controlling set interval. This is the interval that results in the largest number of changes. Dividing the estimated mileage by the set mileage yields the minimum number of changes based on mileage. For the two-mileage estimates, this is 1.67 and 0.37 oil changes per-year, respectively. A set period of semi-annual oil changes requires a change every six months, for a total of two per-year. Therefore, the set period is the controlling interval.

The next step is to determine the cost of each oil change. This was accomplished in Chapter III, estimating a calculated cost of \$113.72.

The final step is to multiply the equivalent systems (1,231.25), cost per-change, and minimum number of changes. For HA transmission, this results in \$280,035.50. Table 4.2 summarizes annual costs for each component. The total annual cost avoidance is \$3,465,060. Fractions of systems are not rounded. This better approximates the percentage of the systems that would reach their change criteria during CY 1999.

Filter disposal costs must be added to this value. This is determined by multiplying the average disposal cost of \$0.16 per-filter, number of changes per-system, and the quantity of filters per-system found in Table 3.5. This yields a disposal cost of \$8,897 for a total cost of \$3,473,958.

<u>CAT</u>	<u>Component</u>	<u>Equivalent Systems</u>	<u>Number Changes</u>	<u>Cost per Change</u>	<u>Annual Cost</u>
HA	T	1,231.25	2	\$113.72	\$280,035.50
	E	1,231.25	2	\$41.98	\$103,375.75
LA	T	1,627.75	1	\$429.73	\$699,493.00
	E	1,627.75	2	\$26.66	\$86,791.63
HC	T	134.75	4	\$33.34	\$17,970.26
	E	134.75	12	\$76.15	\$123,134.55
	HS	134.75	2	\$248.57	\$66,989.62
LC	T	191.25	2	\$79.95	\$30,580.88
	E	191.25	2	\$19.43	\$7,431.98
	HS	191.25	2	\$128.58	\$49,181.85
LTV	T	3,666.5	0.5	\$39.99	\$73,311.67
	E	3,666.5	2	\$18.46	\$135,367.18
MTV	T	3,160.5	0.5	\$94.88	\$149,934.12
	E	3,160.5	4	\$35.57	\$449,675.94
HTV	T	1,448.75	1	\$55.23	\$80,014.46
	E	1,448.75	2	\$49.80	\$144,295.50
	HS	1,448.75	1	\$153.16	\$221,890.55
SG	E	257.25	14.4	\$14.32	\$53,047.00
MG	E	192.5	14.4	\$19.67	\$54,525.24
LG	E	22.75	14.4	\$28.48	\$9,330.05
M1	T	676	0.5	\$323.00	\$109,174.00
	E	676	2	\$164.60	\$222,539.20
	HS	676	0.5	\$678.15	\$229,214.70

**Table 4.2. Costs Avoided by System**

As mentioned previously, most of this data comes from PMOs. Additional sources were used to support data collected from the PMOs. Several discrepancies existed between the various sources. According to the MTV PMO, without AOAP, there are only mileage and not time directed oil changes. However, the LO found on the Logistics Support Activity (LOGSA) web site has specific time periods listed. Because units will follow the LO, this thesis uses the LO.

Other discrepancies exist between the mileage estimates. This is insignificant however, because mileage based changes are never the controlling factor. Based on the data in Table 4.1, the time period interval is the controlling factor for all oil changes except for generators (SG, MG, and LG).

For generators, hours are the most significant factor. For generators, the planning hours quoted appear to be high. Operating for 4,320 hours is equivalent to running 24-hours a day for six months. Therefore, an attempt was made to extract this data from the sample database.

The database was not a useful source of actual hours. Almost all of the equipment listed either had no change in hours, no entries (an entry of "999999"), decreased in hours, or recorded very low hours (less than 60). Because of this, the hours submitted by the units was considered unreliable for this thesis. Therefore, the planning value of 4,320 hours was used.

As with the cost of changing oils during the previous chapter, we must also subtract the revenue returned from selling the used oil. A total of 384,001 gallons is required to support the projected oil changes. At \$0.07 per-gallon, Fort Hood would have recovered \$26,880. As with the calculations in the cost chapter, this assumes that there is no oil loss prior to changing. While strictly unrealistic, the calculated number is used for relative comparison purposes. This recovery brings the total benefit of not changing oils at set intervals to \$3,447,078, or \$273.38 per-system.

This value may be artificially low if some of the MAC times are unrealistically low. For example, each of the M1's components reported 0.5 hours as the period to change the oil. However the transmission has to be removed from the vehicle to change its oil. [Ref. 18] This would increase the time associated with that task and increase the resources. These two points are not factored into this analysis. To analyze the possible effect, MAC time impacts will be subjected to a sensitivity analysis.

## **H. PERCEIVED BENEFITS**

The perceived benefit of oil analysis is savings in oil storage. [Ref. 9] The savings in oil storage reflects that units can maintain smaller inventories, order less frequently, and handle oil less frequently.

The by-product of cost savings in oil storage is not applicable to oil analysis. Although oil analysis does reduce oil usage, it does not impact the costs of ordering or storage. In addition, handling oil in preparing for oil changes is included in the MAC times for those tasks. The reason for this is that units carry oils in sufficient quantities to allow them to deploy into a theater and maintain operations based on projected failures prior to the expected re-supply times. For each component failure, the associated oil must be changed. [Ref. 18]

Because units maintain these stocks for deployments, they generally reorder weekly to maintain deployment levels. No matter the quantity of oil ordered, the cost to place the order is relatively constant. The cost is also relatively constant to receive,

handle, and control the inventory. [Ref. 13] Therefore, this aspect is not included as a benefit of oil analysis.

## I. CHAPTER SUMMARY

Many of the costs avoided by using oil analysis are difficult to precisely determine. However, many approximations were used to help determine the impacts they have on the final results.

To better visualize the benefits, Table 4.3 summarizes those discussed here and shows the total benefit of oil analysis.

<u>Benefit Item</u>	<u>Cost Avoided</u>	<u>Per-System</u>
Environment	\$4,766	\$0.38
Maintenance	\$335,000	\$26.57
Readiness	\$134,000	\$10.63
Learning	\$0	\$0.00
Death Avoidance	\$30,277	\$2.40
Injury Avoidance	\$198,722	\$15.76
Oil Changes	\$3,447,078	\$273.38
Total	\$4,149,843	\$329.12

**Table 4.3. Summary of Benefits**

Dividing the benefits of oil analysis by the number of equivalent systems (12,609.25) yields an average benefit of \$329.12 per-system.

## **V. COST-BENEFIT AND SENSITIVITY ANALYSES**

### **A. PURPOSE**

This chapter combines the costs and benefits to determine the Army's net value of the program. This will be accomplished using total magnitudes, ratios, and per-system values. As part of the cost-benefit analysis, several cost scenarios will be assessed to determine the reliability of the initial comparison. This illustrates different cost perspectives and increases confidence in the results.

Finally, the results will be assessed as to sensitivity to changes in many of the inputs. This highlights areas that provide the greatest impacts to the program. Net benefits will be estimated alternative values for each quantifiable cost or benefit.

### **B. COST-BENEFIT ANALYSIS**

The total costs of AOAP from Chapter III were \$1,218,596, or \$96.64 per-system using the Fort Hood lab. The benefits of using oil analysis from Chapter IV were \$4,149,843, which is \$329.12 per-system. Because both these values are based on the same periods in time, they can be directly compared. This results in a net present value for CY 1999 of \$2,931,247. Because this value is greater than zero, AOAP avoids more costs than it incurs for the Fort Hood population.

Dividing the benefits by the costs results in a ratio of 3.40; for every dollar that AOAP invested in the Fort Hood program during CY 1999, there was a \$3.40 return.

This is less than the \$8.00 return on the \$1.00 investment estimated by the AOAP PMO. [Ref. 20] This difference reflects variations in the estimated costs and benefits. Further comparisons using a range of estimates and sensitivity analysis help assess the impacts of differences in estimated values. The AOAP PMO assessment likely includes a more complete spectrum of the program, including all installations and non-ground systems. There is no method to directly compare these two values.

However, to provide a relative comparison, the numbers were recalculated to determine a maximum and minimum range of benefit/cost ratios. Based on identified ranges of input values in the previous chapters, and replicated in Table 5.1, the benefit/cost ratio ranges between 2.60 and 5.06.

<b>Value</b>	<b>Lowering Impact</b>	<b>Used in Thesis</b>	<b>Raising Impact</b>
Filter disposal (per-filter)	\$0.11	\$0.16	\$0.22
Life value (per-life)	\$3 million	\$5 million	\$7 million
Injury Value (per-injury)	\$25,000	\$37,500	\$50,000
Sample time (per-sample)	0.083 hours	0.3 hours	0.5 hours
Operational life	7 years	7 years	14 years

**Table 5.1. Variable Costs**

To reflect the expected underestimation of the MAC times, a 10% increase is applied to the highest impact resulting in additional range of 2.60 to 5.16. Although the MAC times have no definitive range established, there was sufficient evidence to justify this small increase.

A worst case result was also determined. For this, all fixed costs, equipment costs, non-ground system costs, and both COR and installation monitor costs were allocated to ground systems. This resulted in a benefit/cost ratio of 2.25. This same cost

calculation can also be compared to the worst case benefit scenario where benefits are limited to oil changes avoided. This resulted in costs of \$1,755,316 and benefits of \$3,444,297. This benefit/cost ratio is 1.96, which remains a net positive benefit. With these same values, the number of systems was varied to determine the point at which the costs were equal to the benefits. They became equal at 1,387 equivalent systems. This was an 89% reduction in systems.

Finally, the initial findings estimated a savings of \$232.48 per-system. This does not mean that every additional system added to the program will experience these savings, as this value is only applicable for this particular set of data. As the number of systems increases or decreases, savings may increase or decrease as well. Further information will result from the sensitivity analysis.

## **C. SENSITIVITY ANALYSIS**

### **1. Assumptions**

This sensitivity analysis makes several assumptions as the input values are varied to determine their impacts of the outcome of this analysis. One of the major assumptions is that each parameter change affects every system equally. For example, a 10% increase in oil prices increases each type of oil's price by 10%. Another assumption maintains that as the system population changes, there is an equal percentage change in each recommended action. The last assumption is that the number of non-ground systems

does not change. Based on the criticality of aeronautical systems participating in oil analysis, all aeronautical systems on Fort Hood should already be in the program.

## **2. Analysis**

Many of the values used in this thesis have ranges over which the analysis is valid. There is also potential for changes in these values over time. To simplify sensitivity comparisons across variables, each input value will be increased and decreased by 10%. The results are depicted in Table 5.2 for easy reference. To ensure each value returns a meaningful percentage, the ratios will be compared against a value of 3.40544. Because of the multitude of values, relative values of 1, 1.1, and 0.9 are used in some comparisons, and represent 100%, 110%, and 90% of initial values respectively. The spreadsheet used to make these comparisons is provided in Appendix R.

<u>Value</u>	<u>Original</u>	<u>Change</u>	<u>% Change</u>	<u>Cost-Benefit Ratio</u>	<u>% Change</u>
Life (1990)	\$5 M	\$5.5 M	10%	3.40793	0.07%
Injury (1990)	\$37,500	\$41,250	10%	3.42175	0.48%
Readiness	\$2,000	\$2,200	10%	3.41644	0.32%
Maintenance	\$5,000	\$5,500	10%	3.43293	0.81%
<b>Work Week</b>	<b>50 hours</b>	<b>55 hours</b>	<b>10%</b>	<b>3.53247</b>	<b>3.73%</b>
	<b>50 hours</b>	<b>45 hours</b>	<b>-10%</b>	<b>3.26734</b>	<b>-4.06%</b>
<b>% fixed contract cost</b>	<b>40%</b>	<b>44%</b>	<b>10%</b>	<b>3.44299</b>	<b>1.10%</b>
	<b>40%</b>	<b>36%</b>	<b>-10%</b>	<b>3.36871</b>	<b>-1.08%</b>
% fixed utility cost	30%	33%	10%	3.40596	0.02%
<b>MAC times</b>	<b>1</b>	<b>1.1</b>	<b>10%</b>	<b>3.47136</b>	<b>1.94%</b>
	<b>1</b>	<b>0.9</b>	<b>-10%</b>	<b>3.36344</b>	<b>-1.23%</b>
<b># systems</b>	<b>1</b>	<b>1.1</b>	<b>10%</b>	<b>3.44306</b>	<b>1.10%</b>
	<b>1</b>	<b>0.9</b>	<b>-10%</b>	<b>3.36075</b>	<b>-1.31%</b>
<b>Qty oil</b>	<b>1</b>	<b>1.1</b>	<b>10%</b>	<b>3.47585</b>	<b>2.07%</b>
	<b>1</b>	<b>0.9</b>	<b>-10%</b>	<b>3.33428</b>	<b>-2.09%</b>
<b>Cost of oil</b>	<b>1</b>	<b>1.1</b>	<b>10%</b>	<b>3.47376</b>	<b>2.01%</b>
	<b>1</b>	<b>0.9</b>	<b>-10%</b>	<b>3.33624</b>	<b>-2.03%</b>
<b>Sample time</b>	<b>0.3</b>	<b>0.33</b>	<b>10%</b>	<b>3.26726</b>	<b>-4.06%</b>
	<b>0.3</b>	<b>0.27</b>	<b>-10%</b>	<b>3.55583</b>	<b>4.42%</b>
<b>Manpower cost</b>	<b>1</b>	<b>1.1</b>	<b>10%</b>	<b>3.31793</b>	<b>-2.57%</b>
	<b>1</b>	<b>0.9</b>	<b>-10%</b>	<b>3.50145</b>	<b>2.82%</b>
Container cost	\$0.11	\$0.121	10%	3.40269	-0.08%
	\$0.11	\$0.099	-10%	3.40820	0.08%
Filter disposal cost	\$0.16	\$0.176	10%	3.40604	0.02%
<b>Filter cost</b>	<b>1</b>	<b>1.1</b>	<b>10%</b>	<b>3.50365</b>	<b>2.88%</b>
	<b>1</b>	<b>0.9</b>	<b>-10%</b>	<b>3.30558</b>	<b>-2.93%</b>
Cost of Equipment	1	1.1	10%	3.39838	-.217%
Absorbent material	1 Gallon	1.1 Gallons	10%	3.40584	0.01%

**Table 5.2. Sensitivity Analysis**

Because many of the decreases in values resulted in the same magnitude of a change in the benefit/cost ratio, several decreases in values were omitted to allow space to summarize other sensitivities.

Of the 18 values checked for sensitivity, only nine, which are in bold) changed the benefit/cost ratio by more than 1% for a 10% change from the original input value. Only two of these nine are even somewhat controllable by the AOAP PMO and make a difference on the bottom-line cost to the Army. In order of importance, those are sample times and number of systems.

Developing methods that reduce the time required to take each sample could influence the net benefit of the program. A 1.8 minute reduction in time to sample would provide an additional \$0.15 return for every dollar invested in the program. As long as the cost of each 1.8 minute reduction in sample time is less than \$51,538, the net cost does not increase.

The number of systems can only be influenced if there are ground systems whose components are not included in the oil analysis program. If an additional 1,261 systems were added to the program at Fort Hood, and the average specifications of the added systems were the same as the present population, an additional \$0.04 would be returned for each \$1 invested. This impact is slightly understated due to the increased percentage of costs incurred by the ground systems. By holding the non-ground systems constant, the increased percentage of ground systems shifts fixed costs towards ground systems, increasing the cost per-system.

Although the results of this analysis show a slight sensitivity to the percentage of the lab contract that is fixed, there is little effect on the cost to the Army. This cost is simply shifted from non-ground systems to the ground systems. Any sensitivity

demonstrated is somewhat artificial. However, it does demonstrate that sharing fixed costs with other sources increases the savings.

The remaining seven most sensitive variables are functions of the system developers, economic environment, and work environment. Therefore, the AOAP PMO has no significant ability to influence those values.

#### **D. CHAPTER SUMMARY**

This chapter determined that the AOAP provides a net positive benefit. This favorable result is not particularly sensitive to parameter specifications. Even if benefits are minimized and costs maximized, a net positive benefit results.

The sensitivity analysis established that there were nine aspects that could influence the relative net positive benefit. However, the AOAP PMO can only influence one of these aspects: sample time.

This chapter provides the basis for the conclusions and recommendations presented in the following chapter.

THIS PAGE INTENTIONALLY LEFT BLANK

## **VI. CONCLUSION AND RECOMMENDATIONS**

### **A. CHAPTER PURPOSE**

This thesis established the value that the AOAP provides for ground systems to both Fort Hood and the Army. This chapter, will provide conclusions based on the analyses in the previous chapters and make recommendations for the future and suggest areas for further research.

### **B. CONCLUSION**

Based on the cost-benefit and sensitivity analyses, the AOAP provides a net positive benefit to Fort Hood and the Army as a whole. Even if the worst case values were used, this result holds.

In today's world of dwindling budgets and doing more with less, the AOAP provides benefits for units struggling to maintain their Operational Tempo. By avoiding the costs of oils, filters, and manpower, the units are able to focus on other resources to increase training in preparing for their mission.

However, with the ever increasing fight for budget dollars, it seems peculiar that the AOAP does not have more quantifiable savings. With the best data available being estimates of the savings, it is expected that the AOAP does not receive wholehearted support.

Insufficient emphasis has probably been placed on collecting cost savings data because there is an associated cost without a perceived benefit. Prior to this thesis, there was a perception that there were too many AOAP recommendations to "change oil" when the oil still appeared new. Although there may be cases of this such as with the recycled oil problem, overall the savings in changes far outweigh any oil changes that occur earlier than necessary. These same type perceptions probably exist with other aspects of the program and could easily be countered with proactive use of data.

The AOAP is primarily a means of transferring the costs of oil changes from units to the program. Although units may have strong desires to maintain the program for their financial benefit, the units are not the decision-makers. Therefore, there should be more emphasis placed on gathering data to provide these shareholders.

With minimal work, the program should be able to determine the long-term cost savings for each of their recommended maintenance actions. By tracking the associated costs of corrective maintenance actions for both catastrophic failures and AOAP recommendations for maintenance, a cost savings per-recommendation could be determined. The process of units providing feedback to the labs exists, so there is a means to determine when a component fails. The next step would be to collect the cost information for both time and materials.

The design changes identified by AOAP should be easily quantifiable. Any design changes implemented by PMO would typically have specific cost savings estimates associated with them prior to implementation. If they did not clearly save

money, then the idea would not be implemented. By developing partnering relationship with PMOs, information would quickly flow between the AOAP PMO and other organizations. This would identify potential problems more quickly and provide direct feedback as to cost savings from the identified problems.

### **C. RECOMMENDATIONS**

There are six recommendations that would benefit both the Army and the AOAP. Several of these recommendations may require further studies; however, this thesis touches on each.

1. The Army to provide continued and adequate funding support to the AOAP. This ensures that the program continues and can make further improvements. Although this thesis did not research the impacts of the FT-IR and other technology enhancements (OASIS), these enhancements each provide quality control benefits that directly lead to cost avoidance. Further enhancement and improvements in items such as sample times, could increase the return on each dollar invested into the program.

2. The AOAP PMO must collect information to support their claims of \$8 savings for each dollar invested. Without quantifiable data, it is easy to dismiss these claims. Once a claim is questioned in a public forum, it is difficult to overcome undesirable perceptions, even when corroborating data is available. Finding low cost methods to collect data will help the PMO support their program and justify a valuable program for the Army.

3. The AOAP should fund further studies into program benefits. There is a constant supply of students at the Naval Postgraduate School who seek thesis topics. This is a low cost source of research capability. Whether accomplished in house or not, studies should also examine methods to improve the sampling processes or other aspects that provide the largest impacts on the benefit ratio.

4. The AOAP PMO should have labs track all 33 aspects of oil with the FT-IR. This will allow them to compare trends with actual data on equipment performance. This information should be shared with the ground systems' PMOs. This is one of the methods to gain program support and potentially increase benefits at little cost.

5. The AOAP PMO must also develop close partnerships with all equipment PMOs. This allows more effective identification and resolution of potential problems. Quick resolution to these problems can increase savings to the Army and develop many program supporters.

6. The AOAP PMO needs to encourage lab contractors to accept commercial work. As long as the labs have excess capacity, this shares the fixed costs with other customers. This reduces costs to the Army.

#### **D. AREAS FOR FURTHER RESEARCH**

There are several potential areas for further research into oil analysis. These pertain to and could benefit Fort Hood, the Army, and DoD as a whole.

1. Consolidating DoD oil analysis offices. A cost-benefit analysis or a feasibility study should examine merging each of the individual offices into one DoD office. This could reduce some of the fixed overhead costs not addressed in this thesis.

2. A cost-benefit analysis should be conducted for the entire AOAP. This should include ground and non-ground systems, as well as all installations and labs. This could be accomplished in several portions, as with this thesis, and then merged into one conclusion.

3. A cost-benefit analysis or feasibility study should be conducted for outsourcing or privatizing all aspects of the Fort Hood lab operations to the contractor. An analysis of the costs associated with the contractor owning and operating all aspects of the lab could allow Fort Hood and the AOAP PMO to beneficially change the terms for future contracts.

4. A cost benefit analysis is needed on the recycled oil program. The research must answer questions regarding higher concentrations of wear metals that appear to exist in recycled oils. It should also address AOAP's ability to compensate for this problem.

5. An analysis of combining commercial and military oil sample analysis at the Fort Hood lab. Because the Fort Hood lab has sufficient test resources to allow for considerable increases in samples processed, there is capacity for the contractor to accept commercial work. This could spread out the fixed costs associated with the lab and reduce the overall costs to the Army.

THIS PAGE INTENTIONALLY LEFT BLANK

**APPENDIX A. DA FORM 3254-R "FROM REF. 4"**

<b>OIL ANALYSIS RECOMMENDATION AND FEEDBACK</b> For use of this form, see TB 43-0106 and TB 43-0210; the proponent agency is DARCOM.		<b>REQUIREMENT CONTROL SYMBOL</b> CSGLD-1818	
<b>1. TO: FIELD</b> <i>(Include ZIP Code and Telephone Number)</i>	<b>3. LAB RECOMMENDATION NUMBER</b>		
	<b>4. END ITEM MODEL</b>		
	<b>5. END ITEM SERIAL NUMBER</b>		
<b>2. FROM: LABORATORY</b> <i>(Include ZIP Code)</i>	<b>6. COMPONENT TYPE</b>		
	<b>7. COMPONENT SERIAL NUMBER</b>		
	<b>8. COMPONENT TIME</b> <i>(Hours/Miles)</i>		
<b>9. RECOMMENDATION AND REASON FOR ACTION</b>			
<b>10. SIGNATURE AND TITLE OF INITIATOR</b>		<b>11. DATE</b> <i>(Day/Month/Year)</i>	
<b>12. NOTE FOR ARMY AVIATION ONLY:</b> Quality Deficiency Report (QDR). SF 368 will be submitted when maintenance is performed due to impending or incipient failure indicated by oil analysis, Failure Code 916.		<b>13. QDR NUMBER</b>	
<b>14. FEEDBACK</b> <i>(Maintenance Performed/Action Taken)</i>			
<b>15. FROM: FIELD DEPOT MAINTENANCE PERSONNEL</b>		<b>16. DATE</b> <i>(Day/Month/Year)</i>	
<b>17. TO: LABORATORY</b>			
NOTE FOR ARMY AVIATION ONLY: Copy of this form with SF 368 (QDR) attached will be sent to: Commander, CCAD ATTN: DRSTS-MER Stop 55 Corpus Christi, TX 78419 NOTE: AMSAV-MRAT IS NEW ATTN ADDRESS			

**DA FORM 3254-R**  
 NOV 80

EDITION OF JUN 78 IS OBSOLETE.

THIS PAGE INTENTIONALLY LEFT BLANK



THIS PAGE INTENTIONALLY LEFT BLANK

**APPENDIX C. WEAR METAL CONCENTRATION VS. OPERATING HOURS BASED ON REPLENISHMENT OF DEPLETED OIL "From Ref. 3"**

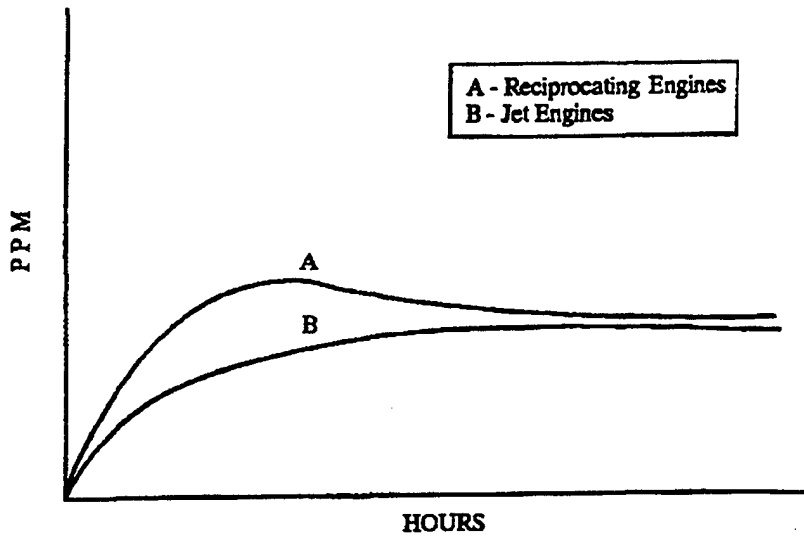

THIS PAGE INTENTIONALLY LEFT BLANK

**APPENDIX D. EFFECT OF PERIODIC FLUID ADDITION AND FLUID CHANGE ON WEAR METAL CONCENTRATIONS "From Ref. 3"**

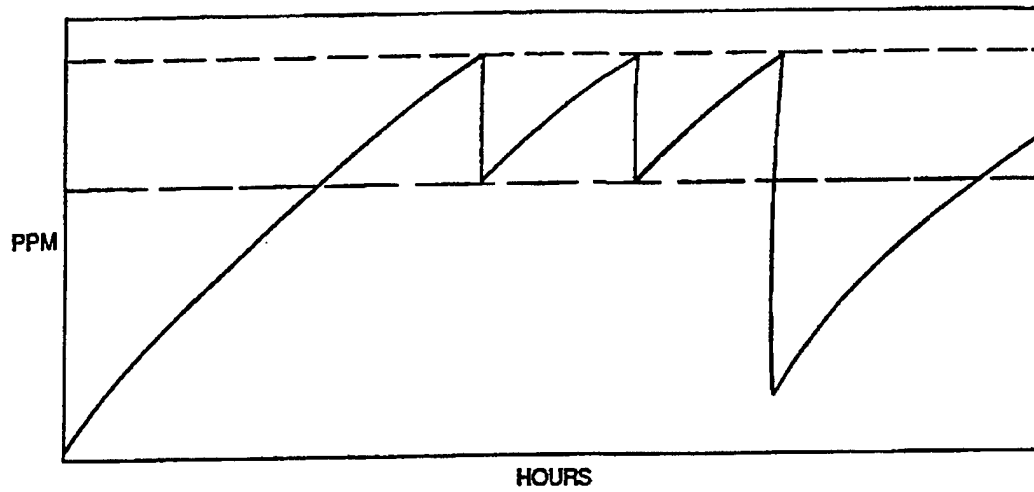

THIS PAGE INTENTIONALLY LEFT BLANK

**APPENDIX E. LABORATORY RECOMMENDATION  
CODES BASED ON SPECTROMETRIC ANALYSIS "From Ref. 4"**

**STANDARD LAB RECOMMENDATION CODES - NON AERONAUTICAL FOR  
SPECTROMETRIC ANALYSIS  
(Not For Air Force Use)**

<b>CODE</b>	<b><u>GENERAL LAB RECOMMENDATIONS</u></b>
A	Sample results Normal, continue routine sampling.
Z	Previous recommendation still applies.
<b>CODE</b>	<b><u>INSPECTION RECOMMENDATIONS (Requires Feedback)</u></b>
H**	Inspect unit and advise lab of finding. Abnormal wear indicated by (element) (PPM). Resample after (maintenance/ *** hours/etc.).
K**	Impending failure, critical wear indicated by (element). Inspect unit and advise lab of findings. Resample after (maintenance/ *** hours/etc.).
L**	Inspect brake and clutch plate adjustments, change oil service filters, resample after *** hours of operation.
M**	Perform engine coast-down check. If engine fails test, examine for discrepancy and advise lab of results, else resample after *** hours of operation.
U**	Cooling system leak indicated by (Mg/Cr/Na/B). Inspect unit and advise lab of findings. Resample after (maintenance/ *** hours/etc.).
<b>CODE</b>	<b><u>OIL CHANGE RECOMMENDATIONS (Requires Resample)</u></b>
D	Change oil and service filters. Resample after *** hours of operation.
<b>CODE</b>	<b><u>LAB REQUESTED RESAMPLES (Requires Resample)</u></b>
B*	Resample ASAP, do NOT change oil.
C*	Resample after *** hours.
F*	Do not change oil, submit special sample after test run. Do not operate until after receipt of laboratory results or advice.
G*	Contamination suspected, resample unit and submit sample from new oil servicing this unit.
I*	Stop purification, resample each engine after 4 hours of operation.
N*	Unit 'wear-in' indicated, resample in accordance with break-in schedule or after *** hours
P*	Do not operate; do not change oil; submit resample ASAP.

**NOTES:**

- \* Resample (red cap) required
- \*\* Maintenance feedback required, advise laboratory of findings
- \*\*\* Laboratory will specify time limit

THIS PAGE INTENTIONALLY LEFT BLANK

APPENDIX F. PHYSICAL TEST RECOMMENDATION CODES "FROM  
REF. 4"

STANDARD LAB RECOMMENDATION CODES — PHYSICAL TEST RECOMMENDATIONS  
(Not For Air Force Use)

<u>CODE</u>	<u>RECOMMENDATION</u>
AA	Oil condition normal, continue routine sampling.
DN	Do not operate.
ER	Evaluate and repair component.
TS	Check oil type and source.
ZZ	Previous recommendation still applies.
<u>CODE</u>	<u>OIL CONDITION STATEMENTS</u>
FD	Fuel Dilution.
NN	Neutralization or acid number.
PC	Particle count excessive.
PN	Precipitation number.
SA	Solid or abrasive material.
VS	Viscosity (high/low/change).
WA	Water
<u>CODE</u>	<u>OIL CHANGE RECOMMENDATIONS</u>
CS	Change oil and service filter.
CP	Purify, renovate or change oil and service filters.
<u>CODE</u>	<u>LAB REQUESTED SAMPLES (Requires Resample).</u>
RB*	Resample ASAP.
RC*	Resample after *** hours.
RH*	Submit hot sample.
RI*	Resample, insufficient amount of sample received.
RS*	Submit sample of new oil servicing this unit.

<b><u>CODE</u></b>	<b><u>INSPECTION RECOMMENDATIONS</u> (Requires Feedback)</b>
<b>IA**</b>	<b>Inspect and repair air induction system.</b>
<b>IC**</b>	<b>Inspect and repair cooling system.</b>
<b>IF**</b>	<b>Inspect and repair fuel system, change/service filters and oil.</b>
<b>IW**</b>	<b>Inspect for source of water.</b>

**NOTES:**

- \* Resample (red cap) required**
- \*\* Maintenance feedback required, advise laboratory of findings**
- \*\*\* Laboratory will specify time limit**

**APPENDIX G. EXAMPLE OF ALLOWED WEAR METAL  
CONCENTRATION FOR SPECIFIC COMPONENT "From Ref. 6"**

COMPONENT: *Caterpillar 3208 (Engine)*

LUBRICANT: *ML-L-2104*

	Fe	Ag	Al	Cr	Cu	Si	Sn	Ni	Pb	Mo	Mg
Normal Range	30-150		0-10	0-3	0-20	0-20			0-25	0-20	
Marginal Range	151-230		11-15	4-12	21-27	21-35			26-40	21-27	
High Range	231-300		16-45	13-20	28-35	36-50			41-75	28-35	
Abnormal	301		46+	21+	36+	51+			76+	36+	
Abnormal Trend (PPM Increase in 10 Hours)	60		9	4	7	10			15	7	

**TECHNICAL INFORMATION**

A faulty air induction system is normally the major source of silicon in engine oil. Antifoaming agents in engine oil normally contain silicone which will give 3 to 7 PPM in new oil. Silicone coatings may also be used in oil-wetted engine parts. Aluminum and cast iron parts in the engine can have significant amounts of silicon in their composition.

Molybdenum (Mo) levels can be employed to determine the condition of the top (fire) ring. Molybdenum may be present as a dry lubricant or as an additive in some greases, requiring evaluator interpretation.

The engine is liquid-cooled; therefore, ethylene glycol may be present in the engine oil, indicating coolant contamination.

Lead (Pb) is normally generated at relatively high levels during the break-in period of the engine, and then remains fairly constant except for heavy loading, marginal lubrication, or excessive dirt. Increased lead can be the first symptom of bearing distress.

**APPLICABLE END ITEMS**

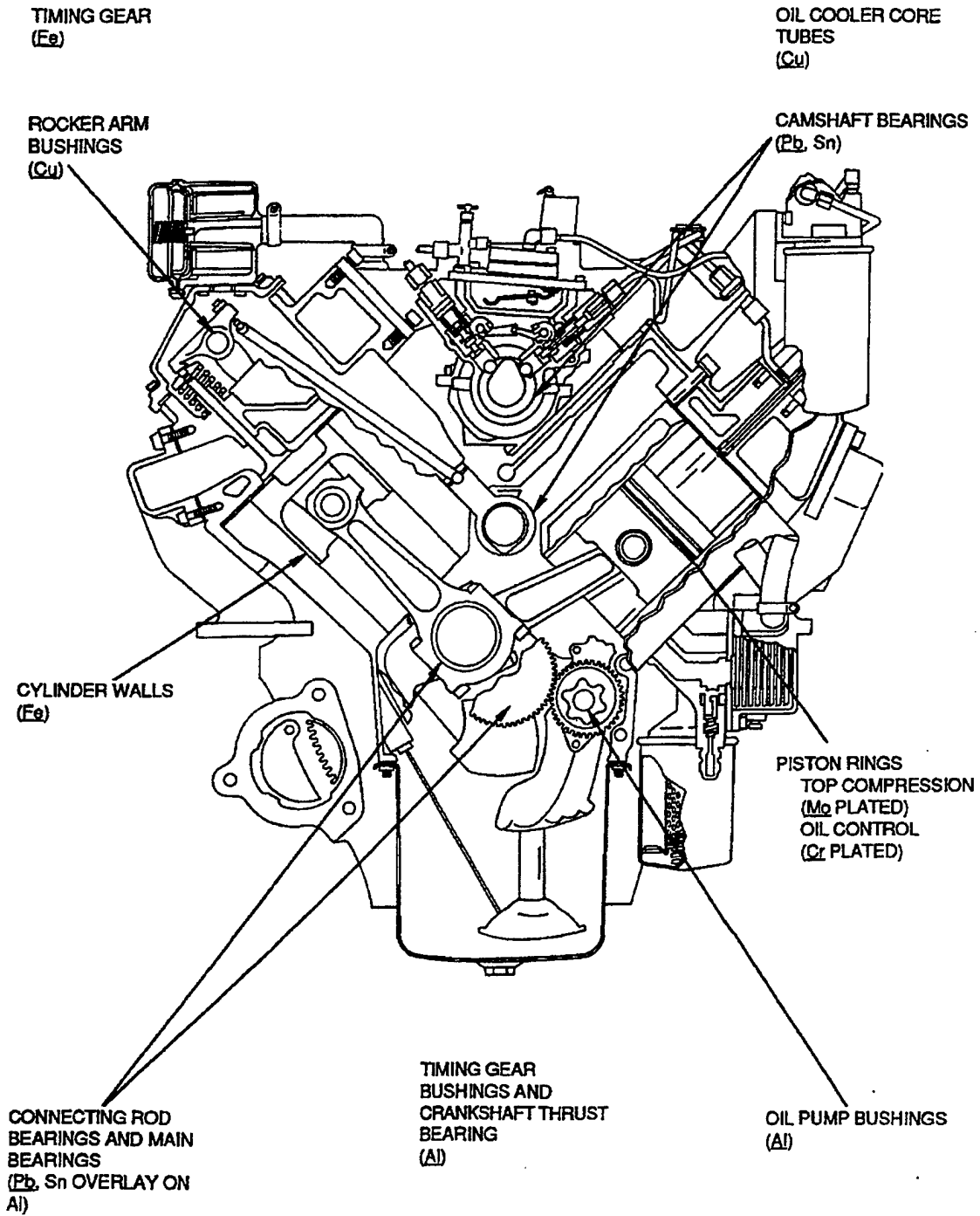

CATERPILLAR 3208

**APPENDIX H. EXAMPLE LUBRICATION CONTAMINATIONS AND  
ASSOCIATED METHOD FOR ANALYSIS DETECTION "From Ref. 6"**

**TABLE 2-3. LUBRICANT CONTAMINANTS**

<u>Contaminant Type</u>	<u>Significance</u>	<u>Analytical Method</u>
Wear metals	System wear	Spectrometer
Coolant	Emulsifies oil, impairs lubrication, destroys dispersant additives	Crackle test; blotter spot; spectro for Na, B
Free Water	Corrosion, emulsifies oil, impairs lubrication	Crackle test; blotter spot; spectro for Na with Marine equipment, visual inspection
Fuel	Lowers oil viscosity	Viscosity; Alkalinity Test
Dirt, sand	Causes abrasive wear	Spectro for Si, Al; blotter spot; visual inspection
Blow-by products, Soot	Increases viscosity, forms sludge	Viscosity; blotter spot;
Reactive compounds	Corrosion, viscosity increase	Viscosity; Alkalinity Test
Rust	Internal Corrosion	Spectro for Fe

THIS PAGE INTENTIONALLY LEFT BLANK

APPENDIX I. DRAIN KIT FOR TAKING OIL SAMPLES "FROM REF. 3"

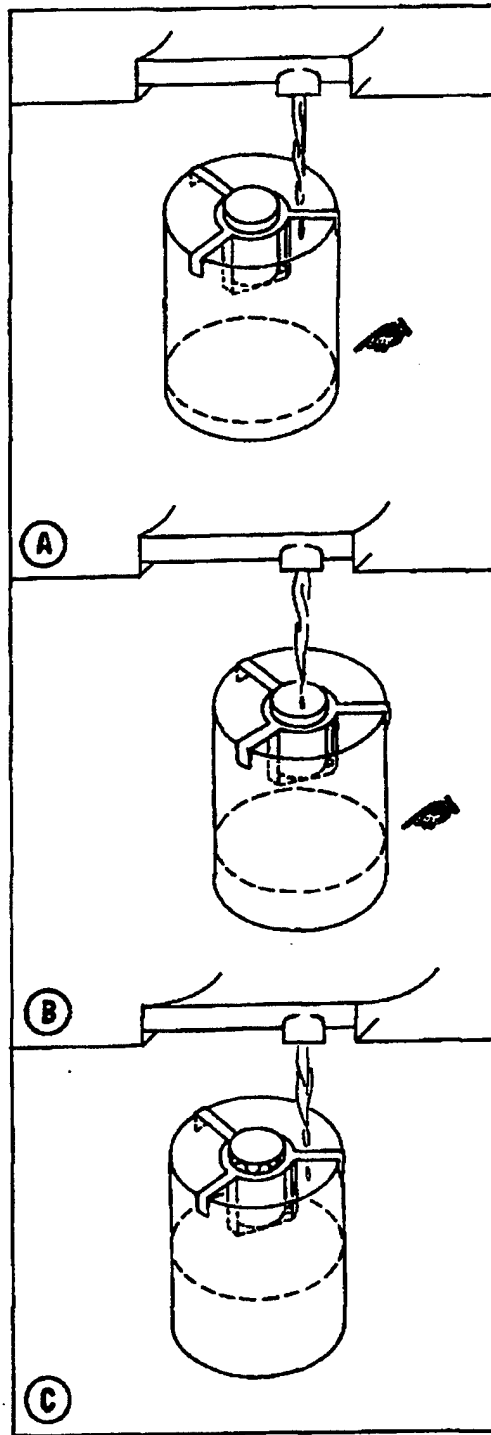
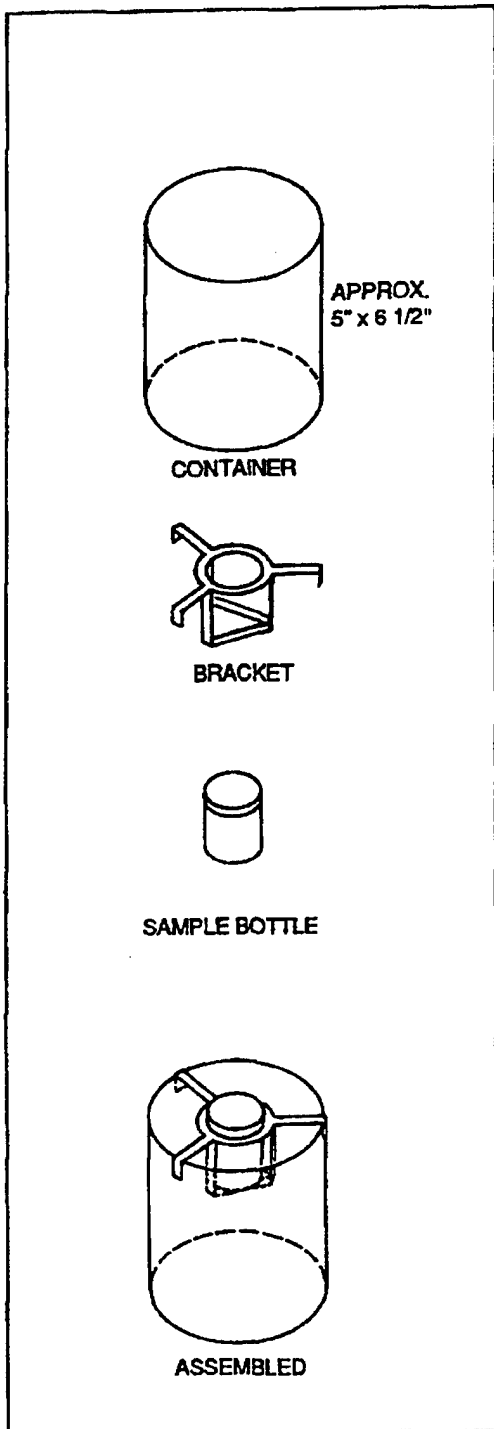

THIS PAGE INTENTIONALLY LEFT BLANK

APPENDIX J. WEAR METAL CONCENTRATIONS VS. OPERATING HOURS  
"FROM REF. 3"

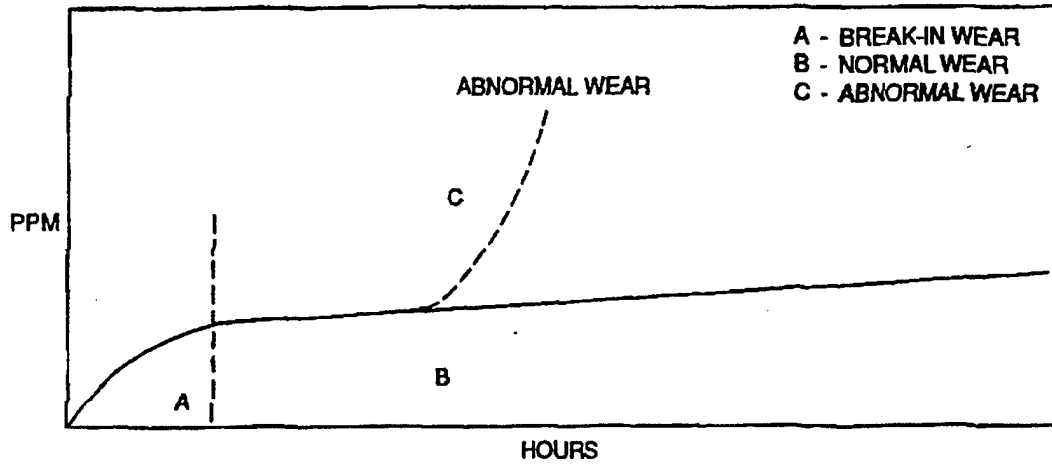

THIS PAGE INTENTIONALLY LEFT BLANK

# Oil Analysis Standard Interservice System (OASIS)

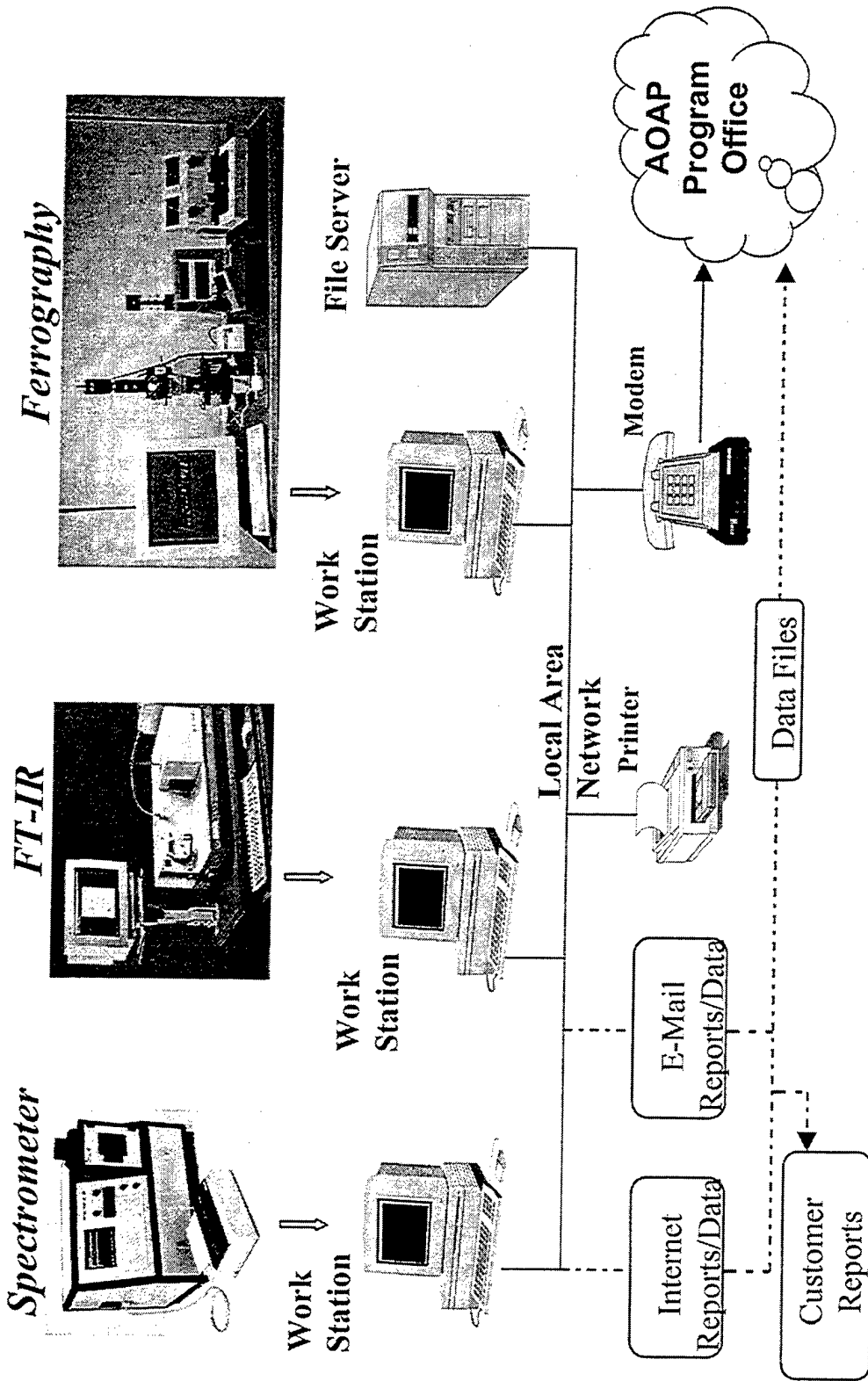

THIS PAGE INTENTIONALLY LEFT BLANK

## APPENDIX L. CATEGORIZATION OF EQUIPMENT AND POPULATION DETERMINATION

Type	Initial Database	CAT	Other Calc	Second Database	EIMQDs with Duplicates	Total Duplicates	Short Duration Usage	Total Systems	Jan thru		Jul thru		UNINSTALLED	1 YR	1/2 YR	1/4 YR
									Jan	Jun	Jul	Dec				
A-10	25	O	25	0	0	0	0	0	0	0	0	0	0	0	0	0
AH-1F	289	O	289	0	0	0	0	0	0	0	0	0	0	0	0	0
AH-1P	2	O	2	0	0	0	0	0	0	0	0	0	0	0	0	0
AH-84A	1367	O	1367	0	0	0	0	0	0	0	0	0	0	0	0	0
AH-64D	118	O	118	0	0	0	0	0	0	0	0	0	0	0	0	0
BE-85	1	O	1	0	0	0	0	0	0	0	0	0	0	0	0	0
BIO-RAD	6	O	6	0	0	0	0	0	0	0	0	0	0	0	0	0
C-12	78	O	78	0	0	0	0	0	0	0	0	0	0	0	0	0
C-23	33	O	33	0	0	0	0	0	0	0	0	0	0	0	0	0
C-9	5	O	5	0	0	0	0	0	0	0	0	0	0	0	0	0
CH-47A	1	O	1	0	0	0	0	0	0	0	0	0	0	0	0	0
CH-47D	570	O	570	0	0	0	0	0	0	0	0	0	0	0	0	0
E-4B	7	O	7	0	0	0	0	0	0	0	0	0	0	0	0	0
EH-1H	8	O	8	0	0	0	0	0	0	0	0	0	0	0	0	0
EH-60A	75	O	75	0	0	0	0	0	0	0	0	0	0	0	0	0
F-16	2	O	2	0	0	0	0	0	0	0	0	0	0	0	0	0
LOC0120T	7	O	7	0	0	0	0	0	0	0	0	0	0	0	0	0
OH-58A	88	O	88	0	0	0	0	0	0	0	0	0	0	0	0	0
OH-58C	6	O	6	0	0	0	0	0	0	0	0	0	0	0	0	0
PWR GEN-AF	1	O	1	0	0	0	0	0	0	0	0	0	0	0	0	0
RC-12D	135	O	135	0	0	0	0	0	0	0	0	0	0	0	0	0
UH-1B	5	O	5	0	0	0	0	0	0	0	0	0	0	0	0	0
UH-1H	41	O	41	0	0	0	0	0	0	0	0	0	0	0	0	0
UH-1V	103	O	103	0	0	0	0	0	0	0	0	0	0	0	0	0
UH-60A	785	O	785	0	0	0	0	0	0	0	0	0	0	0	0	0
UH-80FS	3	O	3	0	0	0	0	0	0	0	0	0	0	0	0	0
UH-60L	562	O	562	0	0	0	0	0	0	0	0	0	0	0	0	0
2385	7	HC	7	0	2	0	0	0	0	0	0	0	0	0	0	0
8218	84	HC	84	0	10	64	0	10	0	0	0	0	0	0	0	0
AT422T	21	HC	21	0	3	21	0	3	0	0	0	0	0	0	0	0
CAT-815F	28	HC	28	0	4	28	0	4	0	0	0	0	0	0	0	0
CAT-D7E	3	HC	3	0	1	3	0	1	0	0	0	0	0	0	0	0
CAT-D7F	16	HC	16	0	6	16	0	6	0	0	0	0	0	0	0	0
CAT-D7G	321	HC	321	0	41	320	0	42	0	0	0	0	0	0	0	0
D7H	1	HC	1	0	0	0	0	0	0	0	0	0	0	0	0	0
LRT-110	223	HC	224	0	31	224	0	31	0	0	0	0	0	0	0	0
M10A	377	HC	377	0	45	377	0	45	0	0	0	0	0	0	0	0
MT250	7	HC	7	0	2	7	0	2	0	0	0	0	0	0	0	0
RTL10	14	HC	14	0	1	14	0	1	0	0	0	0	0	0	0	0
TMS 300-5	3	HC	3	0	1	3	0	1	0	0	0	0	0	0	0	0
D5BS	4	HC	4	0	1	4	0	1	0	0	0	0	0	0	0	0
H446	2	HC	2	0	1	2	0	1	0	0	0	0	0	0	0	0
H446A	1	HC	1	0	0	0	0	0	0	0	0	0	0	0	0	0

Type	Initial Database	GAT	Other Calc	Second Database	EIMODs with Duplicates	Total Duplicates	Short Duration Usage	Total Systems	Jan.thru		Jul.thru		UNINSTALLED	1 YR	1/2 YR	1/4 YR
									Jun	Dec	Jun	Dec				
RT41AA	75 HC		0	75	12	75	0	12	10	10	0	0	0	10	0	2
M109A5	120 HA		0	120	38	118	2	40	5	35	0	0	0	5	30	5
M109A6	1285 HA		0	1287	98	1282	5	103	95	91	0	0	0	91	4	8
M2	519 HA		0	519	138	511	8	148	80	125	19	80	45	80	45	40
M270	378 HA		0	378	36	378	0	36	36	33	0	0	0	33	3	0
M2A1	19 HA		0	17	5	17	0	6	2	3	0	0	0	2	1	2
M2A2	3948 HA		0	4020	492	3997	23	515	366	472	0	0	0	366	108	43
M3	180 HA		0	180	42	179	1	43	37	37	0	0	0	37	0	6
M3A1	8 HA		0	1	0	0	0	1	1	0	0	0	0	0	0	1
M3A2	868 HA		0	873	91	868	5	98	87	46	0	0	0	46	41	9
M48A5	1 HA		0	1	0	0	0	1	1	0	0	0	0	0	0	1
M48A5AVLB	53 HA		0	53	11	52	1	12	2	11	0	0	0	2	9	1
M551	94 HA		0	95	2	95	0	2	2	1	0	0	0	2	1	35
M80	141 HA		0	141	12	141	0	12	11	11	0	0	0	11	0	1
M80A1AVLB	612 HA		0	618	64	617	1	65	51	61	0	0	0	51	10	4
M80A1RISE	5 HA		0	5	2	5	0	2	0	1	0	0	0	0	1	1
M80A3	1 HA		0	1	0	0	0	1	1	0	0	0	0	0	0	1
M88A1	1747 HA		0	1761	211	1753	8	219	174	161	0	0	0	161	13	45
M88A1-MC	6 HA		0	6	1	3	0	4	1	0	0	0	0	0	1	3
M892	73 HA		0	76	6	75	1	7	6	6	0	0	0	6	0	1
M892A1	11 HA		0	11	2	11	0	2	2	1	0	0	0	1	0	1
M892A2	1154 HA		0	1154	91	1154	0	91	90	84	0	0	0	84	6	1
M893	40 HA		0	40	15	35	5	20	10	5	0	0	0	5	5	10
XMT1050	18 HA		0	18	2	10	8	10	0	2	0	0	0	0	2	8
M89A2	524 HA		0	527	62	518	9	71	43	55	0	0	0	43	12	16
AAVR7A1-MC	2 HA		0	2	1	2	0	1	0	1	0	0	0	0	0	1
F5070	1 HTV		0	1	0	0	0	1	1	0	0	0	0	0	0	1
M1000	119 HTV		0	119	20	43	76	96	1	14	0	0	0	0	0	1
M1001	1 HTV		0	1	3	0	0	4	0	0	0	0	0	0	0	4
M1070	1580 HTV		0	1588	145	1585	3	148	145	145	0	0	0	145	0	3
M1074	834 HTV		0	850	98	849	1	99	85	95	0	0	0	85	10	4
M1075	200 HTV		0	204	26	203	1	27	25	24	0	0	0	24	1	2
M123A1C	1 HTV		0	1	0	0	0	1	1	0	0	0	0	0	0	1
M911	443 HTV		0	435	28	428	7	35	25	26	0	0	0	25	1	10
M915	111 HTV		0	111	14	111	0	14	13	14	0	0	0	13	1	0
M915A1	127 HTV		0	127	43	119	8	51	9	41	0	0	0	9	32	10
M916	204 HTV		0	204	31	194	10	41	22	26	0	0	0	22	4	15
M916A1	47 HTV		0	47	7	46	1	8	5	7	0	0	0	5	2	1
M917A1	39 HTV		0	39	9	39	0	9	0	9	0	0	0	0	0	9
M919	27 HTV		0	27	5	27	0	5	4	3	0	0	0	3	1	1
M920	154 HTV		0	154	22	154	0	22	15	19	0	0	0	15	4	3
M977	2377 HTV		0	2397	360	2360	37	397	288	304	146	288	16	288	16	239
M978	3368 HTV		0	3384	609	3354	40	549	378	457	0	0	0	378	79	92

Type	Initial Database		Other Calc	Second Database	EIMODs with Duplicates		Total Duplicates	Short Duration Usage	Total Systems	Jan thru			UNINSTALLED	1 YR	1/2 YR	1/4 YR
	Database	CAT			Duplicates	Duplicates				Jun	Jul thru Dec	Dec				
M883	21	HTV	0	21	5	19	2	7	3	4	0	3	1	3		
M884	118	HTV	0	119	18	112	7	28	14	13	0	13	1	12		
M884A1	783	HTV	0	789	115	791	8	123	86	103	0	86	17	20		
M885	913	HTV	0	915	121	908	7	128	114	100	0	100	14	14		
M885E1	4	HTV	0	4	1	4	0	1	1	0	0	0	0	1	0	
TRACTOR-MC	2	HTV	0	2	1	2	0	1	1	0	0	0	0	1	0	
RTFL	218	LC	0	218	36	208	10	46	25	30	2	0	1	2	0	
178B	6	LC	0	6	1	6	0	1	1	1	0	0	1	0	0	
6000K-MC	2	LC	0	2	1	2	0	1	0	1	0	0	1	0	0	
6000M	345	LC	0	345	57	345	0	57	48	42	0	42	6	9	0	
ARTF-T8	24	LC	0	24	5	24	0	5	4	3	0	3	1	1	0	
BBEUSCSBMK2	155	LC	0	155	14	155	0	14	14	14	0	14	0	0	0	
CAT-130G	68	LC	0	68	9	68	0	9	8	9	0	8	1	0	0	
CAT-130GNS	3	LC	0	3	1	3	0	1	1	1	0	0	0	1	0	
CAT-130GS	6	LC	0	6	1	5	1	2	1	1	0	1	0	1	0	
CB-534B	3	LC	0	3	1	3	0	1	1	1	0	1	0	1	0	
DV43	59	LC	0	59	7	58	1	8	7	7	0	7	0	1	1	
H200H	1	LC	0	1	0	1	0	1	1	1	0	1	0	1	0	
H40XL-MIL	11	LC	0	11	4	10	1	1	1	0	0	0	0	0	0	
H60XL-MIL	11	LC	0	11	4	10	1	5	3	1	0	1	2	2	0	
M4K	388	LC	0	401	4	8	3	7	4	0	0	0	4	3	0	
MHE-270	130	LC	0	130	51	400	1	62	41	42	0	41	1	10	0	
MLT6	7	LC	0	7	13	129	1	14	10	13	0	10	3	1	0	
MW24C	55	LC	0	55	7	7	0	0	1	1	0	0	1	0	0	
RS28	21	LC	0	21	9	55	0	9	6	8	0	6	2	1	0	
SP848	5	LC	0	5	4	21	0	4	3	3	0	3	0	1	0	
T0730HKEG	7	LC	0	7	1	5	0	1	1	0	0	0	0	1	0	
YSD-78	1	LC	0	1	1	7	0	1	1	1	0	0	0	1	0	
250DCMS1	19	LG	0	19	0	0	1	1	1	0	0	0	0	0	0	
MEP-007B	21	LG	0	21	4	18	1	5	3	3	0	3	1	1	0	
MEP-029A	6	LG	0	6	5	21	0	6	1	5	0	1	4	0	0	
MEP-38A	2	LG	0	2	0	0	2	2	0	0	0	0	0	0	0	
PU485A/G	5	LG	0	5	2	5	1	3	0	2	0	0	0	2	1	
PU485B/G	19	LG	0	19	11	54	0	11	10	9	0	9	1	1	0	
P250WDMH288	33	LTV	0	34	5	19	0	5	2	5	0	2	3	0	0	
FLU419	20	LTV	0	20	6	14	20	28	2	1	0	1	1	24	0	
HMMH	500	LTV	0	500	4	20	0	4	3	3	0	3	0	1	0	
M1025	275	LTV	0	275	157	519	15	172	104	98	35	98	6	103	0	
M1025A2	580	LTV	0	587	91	248	27	118	33	60	0	33	27	58	0	
M1028	7	LTV	0	7	164	581	16	180	89	102	0	89	13	78	0	
M1035	2	LTV	0	2	2	6	1	3	1	1	0	1	0	0	2	
M1036	364	LTV	0	367	1	2	0	1	0	0	0	0	0	1	0	
M1037			0		121	357	10	131	72	58	0	58	14	59	0	

Type	Initial Database	CAT	Other Calc	Second Database	EIMOs with Duplicates		Total Duplicates	Short Duration Usage	Total Systems	Jan thru		Jul thru		UNINSTALLED	1 YR	1/2 YR	1/4 YR
					Duplicates	Duplicates				Jun	Jul	Dec					
M1038	928	LTV	0	940	260	909	31	281	139	159	0	139	20	132			
M1038A1	7	LTV	0	7	2	7	0	2	0	0	0	0	0	2	0	0	
M1043A2	50	LTV	0	50	13	37	13	26	9	4	0	4	5	17	0	0	
M1044	23	LTV	0	23	6	18	5	11	7	4	2	2	2	7	0	0	
M1086	12	LTV	0	12	2	12	0	2	2	1	0	1	0	0	0	0	
M1097	893	LTV	0	906	304	878	30	334	104	200	0	104	96	134	0	0	
M1097A1	1721	LTV	0	1728	560	1669	37	597	234	368	0	234	134	229	0	0	
M1097A2	164	LTV	0	165	53	157	8	61	4	48	0	4	44	13	0	0	
M1113	12	LTV	0	12	4	12	0	4	4	4	0	0	0	4	0	0	
M1114	34	LTV	0	34	14	29	5	19	10	4	0	4	6	9	0	0	
M986	13	LTV	0	13	4	12	1	5	3	1	0	1	2	2	0	0	
M986	21	LTV	0	21	8	20	1	9	2	5	0	2	3	4	0	0	
M987	285	LTV	0	286	79	258	8	87	34	62	0	34	18	35	0	0	
M987A1	2	LTV	0	2	0	0	0	2	2	0	0	0	0	2	0	0	
M988	10808	LTV	0	10905	3205	10681	244	3449	1748	1856	0	1748	112	1589	0	0	
M988A1	1015	LTV	0	1013	329	887	26	355	110	206	0	110	96	149	0	0	
M988A2	3	LTV	0	3	1	3	0	1	1	0	0	0	0	1	0	0	
SEE	176	LTV	0	175	40	164	11	51	21	31	0	21	10	20	0	0	
IM1	43	MI	0	44	10	35	9	19	9	4	0	4	5	10	0	0	
M1A1	3055	MI	0	3072	429	3042	30	459	358	339	0	339	19	101	0	0	
M1A2	2532	MI	0	2538	346	2518	20	368	240	327	0	240	87	39	0	0	
AN/MJQ-10A	30	MG	0	30	7	30	0	7	6	4	0	4	2	1	0	0	
AN/MJQ-12	2	MG	0	2	0	0	2	2	2	0	0	0	0	2	0	0	
AN/MJQ-12A	9	MG	0	8	2	6	2	4	2	4	0	0	0	2	0	0	
AN/MJQ-40	87	MG	0	87	12	86	1	13	8	9	0	8	1	4	0	0	
AN/MJQ-41	7	MG	0	9	1	8	1	2	1	1	1	0	1	0	0	0	
MEP-005A	94	MG	0	94	22	85	9	31	18	13	4	13	5	17	0	0	
MEP-008A	46	MG	0	48	12	46	2	14	8	7	0	7	1	6	0	0	
MEP-105A	4	MG	0	4	2	4	0	2	2	0	0	0	0	2	0	0	
MEP-114A	6	MG	0	6	1	2	4	5	4	1	0	0	0	1	0	0	
MEP-805A	98	MG	0	98	23	90	8	31	14	19	0	14	6	12	0	0	
MEP-808A	18	MG	0	33	8	32	1	9	6	7	0	6	1	2	0	0	
MEP-815A	1	MG	0	1	0	0	1	1	0	0	0	0	0	1	0	0	
MEP-816A	13	MG	0	13	4	12	1	5	4	0	0	0	0	4	0	0	
PU406AM	7	MG	0	7	2	6	1	3	1	1	0	1	0	2	0	0	
PU406B/M	156	MG	0	162	39	154	8	47	24	30	0	24	6	17	0	0	
PU650B/G	104	MG	0	109	27	108	1	28	15	20	0	15	5	8	0	0	
PU707AM	1	MG	0	1	0	0	1	1	1	0	0	0	0	1	0	0	
PU760M	1	MG	0	1	0	0	1	1	1	0	0	0	0	1	0	0	
PU803	96	MG	0	93	24	85	8	32	9	18	0	9	9	14	0	0	
PU805	153	MG	0	145	35	141	4	39	17	30	0	17	13	9	0	0	
PU806	3	MG	0	3	0	0	3	3	3	0	0	0	0	3	0	0	
M1078	2481	MTV	0	2465	473	2444	21	494	293	441	0	293	148	53	0	0	

Type	Initial Database	CAT	Other Calc	Second Database	EIMODs with Duplicates	Total Duplicates	Short Duration Usage	Total Systems	Jan thru Jun	Jul thru Dec	UNINSTALLED	1 YR	12 YR	14 YR
M1079	1	MTV	0	1	0	0	1	1	0	0	0	0	0	1
M1083	4	MTV	0	4	1	4	0	0	0	1	0	0	0	1
M1085	13	MTV	0	13	4	13	0	0	0	4	0	0	0	4
M1086	5	MTV	0	5	2	5	0	2	2	0	0	0	0	2
M109A1	5	MTV	0	5	1	5	0	1	1	1	2	1	0	2
M109A2	13	MTV	0	11	2	11	0	2	1	1	0	1	1	0
M109A3	489	MTV	0	600	121	469	31	152	74	98	0	74	24	54
M185A3	18	MTV	0	18	5	18	0	5	2	4	0	2	2	1
M292A5	4	MTV	0	4	1	4	0	1	1	1	0	1	0	0
M35A1	17	MTV	0	17	5	17	0	5	3	3	0	3	0	2
M35A2	1944	MTV	0	1959	507	1857	102	609	347	321	0	321	26	262
M35A2C	579	MTV	0	583	142	562	21	183	89	97	0	89	8	66
M35A3	1	MTV	0	1	0	0	1	1	0	0	0	0	0	1
M36A2	65	MTV	0	65	16	64	1	17	11	13	0	11	2	4
M36A3	4	MTV	0	4	1	4	0	1	1	1	0	1	0	0
M50A2	3	MTV	0	3	1	3	0	1	1	1	0	1	0	0
M55A2	4	MTV	0	4	1	4	0	1	1	1	0	1	0	0
M813	2	MTV	0	2	1	2	0	1	0	0	0	0	0	1
M813A1	15	MTV	0	15	5	15	0	3	0	0	0	0	0	3
M814	3	MTV	0	3	1	3	0	1	1	1	0	1	0	1
M815	3	MTV	0	3	1	3	0	1	1	1	0	1	0	1
M816	18	MTV	0	18	5	18	0	5	5	2	0	2	3	0
M820	70	MTV	0	70	17	69	1	12	13	15	0	13	2	3
M820A2	44	MTV	0	45	10	43	2	12	9	7	0	7	2	3
M878A1	34	MTV	0	34	3	34	0	3	3	3	0	3	0	0
M923	2711	MTV	0	2716	385	2706	10	395	319	360	0	319	41	35
M923A1	154	MTV	0	161	26	157	4	30	15	25	0	15	10	5
M923A2	2589	MTV	0	2612	362	2608	4	368	315	338	0	315	23	28
M925	964	MTV	0	961	119	958	3	122	107	113	0	107	6	9
M925A1	282	MTV	0	283	38	282	1	39	31	38	0	31	7	1
M925A2	1463	MTV	0	1473	163	1471	2	165	147	157	0	147	10	8
M926	6	MTV	0	6	1	6	0	1	1	1	0	1	0	0
M927	142	MTV	0	143	22	140	3	25	15	20	0	15	5	6
M927A1	236	MTV	0	240	37	240	0	37	31	30	0	30	1	6
M927A2	119	MTV	0	123	17	123	0	17	16	15	0	15	1	1
M928	39	MTV	0	48	7	48	0	7	6	5	0	5	1	1
M928A1	8	MTV	0	10	2	10	0	2	1	2	0	1	1	0
M928A2	75	MTV	0	77	11	77	0	11	10	10	0	10	0	1
M929	70	MTV	0	70	10	70	0	10	8	10	0	8	2	2
M929A2	213	MTV	0	213	28	212	1	29	23	26	0	23	3	3
M930	1	MTV	0	1	0	0	1	1	0	0	0	0	0	1
M931	1196	MTV	0	1198	144	1198	0	144	122	135	0	122	13	9
M931A1	649	MTV	0	659	87	657	2	89	76	78	0	78	2	11

Type	Initial		CAT	Other Calc	Second Database		EMODs with Duplicates		Total Duplicates		Short Duration Usage		Total Systems		UNINSTALLED				1/4 YR
	Database	3276			MTV	0	3285	177	MTV	22	399	3283	177	1	401	364	Jan thru Jun	Jul thru Dec	
M831A2	3276	MTV	0	3285	177	MTV	22	399	3283	177	1	401	364	388	0	364	24	13	
M832	174	MTV	0	175	392	MTV	53	399	396	399	0	22	19	19	0	19	2	2	
M832A1	456	MTV	0	460	113	MTV	18	113	109	113	1	69	58	63	0	58	12	6	
M832A2	527	MTV	0	540	375	MTV	73	375	536	375	4	77	63	70	0	63	7	7	
M834	29	MTV	0	29	589	MTV	3	589	588	589	1	4	4	3	0	3	0	1	
M834A1	589	MTV	0	592	8	MTV	0	8	8	589	6	83	61	74	0	61	13	9	
M834A2	34	MTV	0	34	231	MTV	8	231	222	34	1	9	4	5	0	4	1	4	
M844	35	SG	0	35	6	SG	6	6	35	6	0	6	6	4	0	4	56	11	
M845	3	SG	0	3	1	SG	1	1	2	3	1	2	0	0	0	0	0	2	
ANMIJQ-37	71	SG	0	72	22	SG	22	22	67	71	5	27	12	10	0	10	2	15	
MEP-003A	1	SG	0	1	0	SG	0	0	0	1	1	1	0	0	0	0	0	1	
MEP-104A	4	SG	0	4	0	SG	0	0	0	4	0	0	0	0	0	0	0	0	
MEP-380A	61	SG	0	61	15	SG	15	15	60	61	1	18	13	13	0	13	0	3	
MEP-382A	24	SG	0	24	4	SG	4	4	24	24	0	4	4	1	3	0	1	2	
MEP-802A	98	SG	0	98	33	SG	33	33	92	98	6	39	12	24	0	12	12	15	
MEP-803A	25	SG	0	23	5	SG	5	5	16	25	7	12	3	3	0	3	0	8	
MEP-804A	33	SG	0	33	9	SG	9	9	27	33	6	15	4	6	1	4	2	10	
MEP-813A	37	SG	0	37	6	SG	6	6	37	37	0	8	5	7	0	5	2	1	
MEP-814A	2	SG	0	2	0	SG	0	0	0	2	2	2	2	0	0	0	0	2	
PU405A/M	165	SG	0	169	43	SG	43	43	162	165	7	50	33	26	0	26	7	17	
PU797	73	SG	0	110	21	SG	21	21	109	73	1	22	14	19	0	14	6	3	
PU797A	189	SG	0	188	36	SG	36	36	167	189	31	69	20	32	0	20	12	37	
PU798	266	SG	0	275	63	SG	63	63	264	266	11	64	35	48	0	35	11	18	
PU798A	101	SG	0	101	22	SG	22	22	80	101	11	33	5	22	0	5	17	11	
PU801	12	SG	0	12	4	SG	4	4	12	12	0	4	4	3	0	2	1	1	
PU802	125	SG	0	124	32	SG	32	32	119	125	5	37	18	26	0	18	8	11	
M548	4	LA	0	4	2	LA	2	2	4	4	0	2	2	2	0	0	2	0	
M548A1	156	LA	0	156	66	LA	66	66	154	156	2	68	14	58	0	14	42	12	
M548A3	378	LA	0	377	38	LA	38	38	377	378	0	38	36	31	0	31	5	2	
LAV-25-MC	1	LA	0	1	0	LA	0	0	0	1	1	1	1	0	0	0	0	1	
M1059	25	LA	0	24	5	LA	5	5	23	25	1	6	5	4	0	4	1	1	
M1064	444	LA	0	444	81	LA	81	81	443	444	1	82	71	57	0	57	14	11	
M1064A3	560	LA	0	561	68	LA	68	68	559	560	2	70	48	63	0	48	15	7	
M1068	1523	LA	0	1531	150	LA	150	150	1524	1523	7	157	126	141	0	126	15	16	
M106A1	2	LA	0	2	1	LA	1	1	2	2	0	1	1	0	0	0	1	0	
M106A2	114	LA	0	114	19	LA	19	19	111	114	3	22	17	7	0	7	10	5	
M113A1	39	LA	0	39	7	LA	7	7	36	39	4	11	3	4	0	3	1	7	

Type	Initial Database	GAT	Other Calc	Second Database	EMODs with Duplicates	Total Duplicates	Short Duration Usage	Total Systems	Jan thru		Jul thru		UNINSTALLED	1 YR	1/2 YR	1/4 YR
									Jun	Dec	Jun	Dec				
M113A2	3125	LA	0	3139	524	3118	23	547	412	369	43	237	102	369	43	237
M113A3	2688	LA	0	2724	352	2714	10	362	265	306	41	58	0	265	41	58
M577A1	23	LA	0	16	4	18	0	4	4	1	3	0	0	1	3	0
M577A2	2144	LA	0	2152	350	2141	11	361	263	288	35	73	0	263	35	73
M577A3	2	LA	0	2	0	0	2	2	0	0	0	0	0	0	0	0
M578	10	LA	0	10	2	10	0	2	2	1	1	0	0	1	1	0
M58	146	LA	0	160	34	158	2	36	0	34	0	0	0	0	34	2
M667	1	LA	0	1	0	0	1	1	0	0	0	0	0	0	0	1
M8	732	LA	0	741	78	737	4	82	70	64	6	13	1	84	6	13
M881	1217	LA	0	1238	135	1229	7	142	99	121	21	21	0	99	22	21
M881A1	38	LA	0	38	6	34	5	11	6	5	1	5	0	5	1	5
M9-MC	2	LA	0	2	1	2	0	0	1	0	0	0	0	0	0	0
XM83FOX	129	LA	0	141	20	141	0	20	19	13	6	1	0	13	6	1
UNINSTALLED	431		0	418	0	0	0	0	0	0	0	0	0	0	0	0

THIS PAGE INTENTIONALLY LEFT BLANK

**APPENDIX M. SAMPLE CORRELATION TEST REPORT MESSAGE "FROM  
REF. 4"**

**SAMPLE MESSAGE FORMAT FOR REPORTING CORRELATION RESULTS**

**FROM: LABORATORY**  
**TO: DIRJOAP TSC PENSACOLA FL**  
**UNCLAS**  
**SUBJ: CORRELATION TEST RESULTS FOR (Month)**

**1. DATE RECEIVED AND DATE ANALYZED (3 Dec 86/4 Dec 86)**

2. SAMPLE	Fe	Ag	Al	Cr	Cu	Mg	Na	Ni	Pb	Si	Sn	Ti	B	Mo	Zn
1	21	14	47	16	20	15	53	30	5	21	7	19	4	5	7
2	17	12	40	13	16	13	49	25	4	17	6	16	3	5	6
3	9	1	1	9	5	1	15	8	3	2	3	0	3	10	4
4	10	2	1	8	4	1	12	7	2	2	3	0	3	11	3

(Round off results to nearest whole PPM)

3. NUMBER OF QUALIFIED OPERATORS/EVALUATORS (One/One)
4. SPECTROMETER MODEL AND SERIAL NO. (FAS-2C 0015)
5. STANDARDS USED FOR STANDARDIZATION (10 PPM MB20 Dec 86/100 PPM MB80 Sep 86)
6. DISC ELECTRODE MFG AND LOT NO. (AE Only) (Ultra Carbon Lot 942-7-2)
7. ROD ELECTRODE MFG AND LOT NO. (AE Only) (Ultra Carbon Lot 234-5)
8. DILUTION RATIO (AA Only) (9:1 all elements except 3:1 for Si and Ti)
9. DILUTENT (AA Only) (MIBK)
10. GASES USED (AA Only) (C<sub>2</sub>H<sub>2</sub>/Air for all elements except Al, Si, and Ti used C<sub>2</sub>H<sub>2</sub>/N<sub>2</sub>O)
11. REMARKS

THIS PAGE INTENTIONALLY LEFT BLANK

**APPENDIX N. CORRELATION SCORING "FROM REF. 4"**

**TABLE 3-1. CORRELATION ELEMENTS AND SCORE WEIGHTING SCHEME**

Element	Symbol	No Data or Fails Reproducibility 1 or 2	
		JOAP AE Rotrode	AA/ICP/etc.
Iron	Fe	3.33	5.55
Silver	Ag	3.33	5.55
Aluminum	Al	3.33	5.55
Chromium	Cr	3.33	5.55
Copper	Cu	3.33	5.55
Magnesium	Mg	3.33	5.55
Sodium	Na	3.33	-
Nickel	Ni	3.33	5.55
Lead	Pb	3.33	-
Silicon	Si	3.33	5.55
Tin	Sn	3.33	-
Titanium	Ti	3.33	5.55
Boron	B	3.33	-
Molybdenum	Mo	3.33	-
Zinc	Zn	3.33	-

THIS PAGE INTENTIONALLY LEFT BLANK

APPENDIX O. AOAP RECOMMENDATION SEQUENCE

COMPSN	COMPMOD	EISN	EIMOD	SAMPDATE	LREC	PREC1	PREC2	MILEAGE	HRSRCOMP	CATEGORY
047734E	6.2 L DIESEL	27258	M998	8/2/99	B	AA		42862	42862	LTV
047734E	6.2 L DIESEL	27207	M998	9/8/99	B	IW	IC	18869	18869	LTV
08VF160259	DD8V92TA	7R1049421	M1070	12/3/99	A	WA	RC	9583	999999	HTV
08VF160259	DD8V92TA	7R1049421	M1070	12/7/99	A	IW	IC	9583	999999	HTV
08VF161605	DD8V92TA	7R1049421	M1070	10/12/99	A	WA	RH	9544	999999	HTV
08VF161605	DD8V92TA	7R1049421	M1070	10/18/99	A	WA	CS	9544	999999	HTV
08VF161605	DD8V92TA	7R1049421	M1070	10/26/99	A	IW	IC	9544	999999	HTV
8VF114707	DD8V92TA	1J20H1030254	M984	10/19/99	A	WA	CS	19355	18739	HTV
8VF114707	DD8V92TA	1J20H1030254	M984	10/26/99	A	IW	IC	19355	18739	HTV
08VF160259	DD8V92TA	7R1049421	M1070	12/3/99	A	WA	RC	9583	999999	HTV
08VF160259	DD8V92TA	7R1049421	M1070	12/7/99	A	IW	IC	9583	999999	HTV
08VF161654	DD8V92TA	5R1049417	M1070	1/8/99	A	WA	RH	8879	999999	HTV
08VF161654	DD8V92TA	5R1049417	M1070	1/13/99	A	WA	CS	8917	999999	HTV
08VF161654	DD8V92TA	5R1049417	M1070	1/20/99	A	IC		8917	999999	HTV
144315	DD8V92TA	NONE	UNINSTALLED	3/18/99	A	WA	CS	999999	8001	HTV
144315	DD8V92TA	NONE	UNINSTALLED	3/19/99	A	IC		999999	8001	HTV
6D217026	DD6V53T	NL09TM	M878A1	10/27/99	A	WA	RH	1908	1908	MTV
6D217026	DD6V53T	NL09TM	M878A1	11/3/99	D	WA	CS	1908	1908	MTV
6D217026	DD6V53T	NL09TM	M878A1	11/9/99	A	WA	CS	1908	1908	MTV
6D217026	DD6V53T	NL09TM	M878A1	11/26/99	A	IC	IW	1908	1908	MTV
11055717	NHC-250	C52500127	M925	3/19/99	A	WA	RH	26349	26349	MTV
11055717	NHC-250	C52500127	M925	3/22/99	A	IC		26349	26349	MTV

THIS PAGE INTENTIONALLY LEFT BLANK

APPENDIX P. OIL CHANGE DATA

CATEGORY	COMPONENT	OIL QTY (QUARTS)	OIL TYPE (OE/DO)	OIL COST (66-GAL) (Ref. 28)	FILTER COST (EACH)	FILTER QTY	SET MILEAGE	SET HOURS	SET PERIOD	MAC (HOURS)	ESTIMATE 1	ESTIMATE 2 (Ref. 30)
HA [Ref. 29]	T	56	15W40	\$129.25	\$71.00	1	1,500		S	0.5	2,500	557
	E	20	15W40	\$129.25	\$15.50	1	1,500		S	0.75	2,500	557
LA [Ref. 33]	T	36	15W40	\$129.25	\$398.76	1	6,000		A	0.5	1,500	
	E	18	15W40	\$129.25	\$6.28	1	1,500		S	0.5	1,500	
HC [Ref. 32]	T	20	10	\$147.44	\$10.12	1		250	Q	0.5		
	E	68	30	\$156.53	\$3.72	1		250	M	0.5		
LC [Ref. 32]	T	124	10	\$147.44	\$87.27	1		250	S	5		
	E	68	10	\$147.44	\$11.15	1		500		0.5		
	E	7	30	\$156.53	\$4.63	1		100		0.5		
LTV [Ref. 28]	T	65	10	\$147.44	\$65.38	1		1000		1		
	E	8	Dexron III/III	\$180.07	\$5.62	1	12,000		B	1.5		3,763
MTV [Ref. 34]	T	8	30	\$156.53	\$2.95	1	3,000		S	0.5		3,763
	E	32	15W40	\$129.25	\$23.31	2	24,000		B	1.5	1,800	3,327
	E	25	15W40	\$129.25	\$5.17	1	6,000		Q	0.8	1,800	3,327
HTV [Ref. 27]	T	38	10	\$147.44	\$10.12	1	6,000		A	1		2,688
	E	30	15W40	\$129.25	\$4.68	1	3,000		S	1.4		2,688
SG [Ref. 31]	HS	120	10	\$147.44	\$33.48	1	6,000		A	2		2,688
	E	5.9	15W40	\$129.25	\$3.00	1		300		0.4	4,320	
MG [Ref. 31]	E	15	15W40	\$129.25	\$3.00	1		300		0.4	4,320	
LG [Ref. 31]	E	30	15W40	\$129.25	\$3.00	1		300		0.4	4,320	
MI [Ref. 28]	T	150	30	\$156.53	\$208.45	1			B	0.5		522
	E	25	MIL-1-23699	\$656.15	\$60.22	1			S	0.5		522
HS		60	FRH	\$600.40	\$235.00	2			B	0.5		522

THIS PAGE INTENTIONALLY LEFT BLANK

## APPENDIX Q. TYPE OF WEAR METALS AND SOURCES "FROM REF. 6"

(1) **Iron (Fe).** Iron is one of the most common wear metals found in oil samples. Iron may be generated from the wear of cylinder walls, shafts, gears, rolling element bearings, splines, and numerous other engine or transmission parts. Iron may also be the result of machining chips or debris left in the equipment oil system during manufacture or overhaul. Iron may also be present as a result of rust in some equipment.

(2) **Silver (Ag).** Silver is used as a plating on some oil seals and bushings and may also be found in small amounts in some sleeve bushings.

(3) **Aluminum (Al).** Aluminum may be found in the oil systems of engines and transmissions because of the wear of pistons, washers, shims, some oil pumps, torque converters, housings or cases, etc. It may also be the result of machining chips or debris left in the equipment oil system during manufacture or overhaul.

(4) **Chromium (Cr).** Chromium in the oil system may result from the wear of numerous oil-wetted parts that are alloyed or plated with chromium. The most common occurrence will probably result from wear of chromium plated piston rings.

(5) **Copper (Cu).** Copper is found in connecting rod and main bearings, many bushings, thrust washers and piston pin bearings. Also, many transmission and brake plates contain sintered bronze, which is very high in copper content.

(6) **Silicon (Si).** Although not a metallic element, silicon is commonly present in many oil systems and may be detected by spectrometric testing. The main source of silicon in engines (silica) is from external sources through the air induction system, which may admit significant amounts of dirt or sand if not maintained properly. Silicon may also be introduced in the form of dirt or sand during maintenance if proper maintenance practices are not observed. Aluminum and cast iron parts used in both engines and transmissions have significant amounts of silicon. Some seals and gaskets, as well as antifoaming agents in oils, also contain silicon and/or silicone.

(7) **Tin (Sn).** Tin is used to plate some engine pistons and may also be present in connecting rod and main bearings, many bushings, thrust washers and piston pin bearings.

(8) **Nickel (Ni)** Nickel is used for plating and as an alloying element in many oil-wetted components. Some cast irons and stainless steels contain significant amounts of nickel.

(9) **Lead (Pb).** Lead is used for plating and may be found in significant amounts in connecting rod and main bearings, bushings, thrust washers and piston pin bearings. Lead may also be found in transmission clutch and brake friction plates.

(10) **Molybdenum (Mo).** Molybdenum is used as an alloying element in many oil-wetted engine and transmission components. Molybdenum is also used as a coating on the top, second, and third compression rings in the Continental AVDS 1790 engines and on the top ring of the Caterpillar 3208 engines.

(11) **Magnesium (Mg).** Magnesium is used as an alloying element in some oil-wetted components but is not employed extensively for nonaeronautical vehicles where weight is a less significant factor.

THIS PAGE INTENTIONALLY LEFT BLANK

## APPENDIX R. SENSITIVITY ANALYSIS

cat	component	oil qty	oil type	oil cost	filter qty	filter cost	rec change	set int change	equiv sys	mac	samples	oil cost per year	without oil analysis filter cost per year	man cost per year	waste recover
HA	T	56	15	\$129.25	1	\$71.00	186		2	1,231.25	0.5	\$81,016.25	\$174,837.50	\$24,182.07	\$2,413.25
	E	20	15	\$129.25	1	\$15.50	178		2	1,231.25	0.75	\$28,934.38	\$38,168.75	\$36,273.10	\$861.88
LA	T	36	15	\$129.25	1	\$398.76	59		1	1,627.75	0.5	\$34,426.91	\$649,081.59	\$15,984.71	\$1,025.48
	E	18	15	\$129.25	1	\$6.26	355		2	1,627.75	0.5	\$34,426.91	\$20,379.43	\$31,989.43	\$1,025.48
HC	T	20	10	\$147.44	1	\$10.12	17		4	134.75	0.5	\$7,224.56	\$5,454.68	\$5,293.05	\$188.65
	E	88	30	\$156.53	1	\$3.72	23		12	134.75	0.5	\$101,243.60	\$6,015.24	\$15,879.15	\$2,490.18
LC	T	124	10	\$147.44	1	\$67.27	1		4	191.25	0.5	\$23,396.14	\$18,129.27	\$26,465.25	\$584.82
	E	98	10	\$147.44	1	\$11.15	32		4	191.25	0.5	\$45,116.64	\$8,529.75	\$7,512.40	\$1,178.10
LTV	T	7	30	\$156.53	1	\$4.63	38		2	191.25	0.5	\$11,430.25	\$25,007.85	\$22,537.20	\$281.14
	E	65	10	\$147.44	1	\$5.38	8		2	191.25	1	\$9,003.09	\$10,302.87	\$54,008.25	\$435.09
MTV	T	8	30	\$156.53	1	\$5.62	151		2	3,666.50	1.5	\$21,662.40	\$21,632.35	\$72,011.00	\$1,026.62
	E	32	15	\$129.25	2	\$23.31	267		2	3,666.50	0.5	\$28,708.70	\$73,671.26	\$46,554.78	\$884.94
HTV	T	36	10	\$147.44	1	\$5.17	242		4	3,160.50	0.8	\$185,678.38	\$185,678.38	\$198,633.71	\$5,530.88
	E	30	15	\$129.25	1	\$10.12	41		2	1,448.75	1	\$36,895.18	\$14,661.35	\$28,453.62	\$963.42
SG	E	120	10	\$147.44	1	\$3.46	20		2	1,448.75	1.4	\$51,068.44	\$13,960.30	\$79,870.71	\$1,521.19
MG	E	5.9	15	\$129.25	1	\$3.00	60		1	1,448.75	2	\$116,511.11	\$48,475.18	\$56,907.65	\$3,042.38
LG	E	15	15	\$129.25	1	\$3.00	65		14.4	257.25	0.4	\$12,840.38	\$11,113.20	\$29,102.15	\$382.48
MT	E	30	15	\$129.25	1	\$3.00	45		14.4	192.5	0.4	\$24,428.25	\$6,316.00	\$21,777.12	\$727.65
	E	150	30	\$156.53	1	\$208.45	95		0.5	676	0.5	\$5,773.95	\$892.80	\$2,573.66	\$171.99
extra	HS	80	15	\$656.15	1	\$80.22	77		2	676	0.5	\$36,073.05	\$89,780.10	\$3,319.20	\$887.25
	HS	103	10	\$147.44	1	\$225.00	15		0.5	676	0.5	\$100,808.50	\$108,457.44	\$13,276.81	\$591.50
	HS	103	10	\$147.44	1	\$55.37	114		0.5	2.67	2.67	\$73,794.62	\$152,100.00	\$3,319.20	\$473.20
cost e4 all army \$48,782.14	cost e4 all army \$51,064.67	database 2 ground 89705	report ground 94949	report ground 5205x52	report ground 568	total/ys						\$1,107,202.11	\$1,554,641.88	\$803,216.82	\$26,880.04
												\$3,447,078.36	\$3,447,078.36		
												utilities \$5,528.00	facilities \$3,044.00	chem	supplies
												% fixed 30%	% fixed 100%		
database 1 non-ground 4315	database 1 ground 93338	report a/c 89705	report ground 94949	report a/c 5205x52	report ground 568	total/ys						MAC manpower 1.00	man cost 1.00	oil cost 1.00	oil qty 1.00
												oil at lab weight per drum 550	contract \$365,000.00	oil cost 1.00	oil qty 1.00
												% fixed 40%	% fixed 40%		
												oil cost 1.00	oil cost 1.00	oil cost 1.00	oil qty 1.00
												sample time 67	sample time 67		
												maint rec 12,609.25	maint rec 12,609.25		
												oil cost 1.00	oil cost 1.00	oil cost 1.00	oil qty 1.00
												PERCENT CHANGE 0.0001%	PERCENT CHANGE 0.0001%		



maint	contract	oil cost			recommend changes			man cost		waste		filter disposal
		per year	per year	per year	per year	per year	per year	per year	recover	disposal		
\$5,940.28	\$199,314.62	\$6,448.40	\$13,916.00	\$1,924.75	\$192.08	196						
		\$2,068.00	\$2,728.00	\$2,592.51	\$61.60	176						
		\$1,247.85	\$23,526.84	\$579.39	\$37.17	59						
		\$3,754.13	\$2,222.30	\$3,486.15	\$111.83	355						
		\$227.86	\$172.04	\$166.94	\$5.95	17						
		\$1,440.08	\$85.56	\$225.86	\$35.42	23						
		\$83.10	\$67.27	\$98.20	\$2.17	1						
		\$1,887.23	\$356.80	\$314.24	\$49.28	32						
		\$189.26	\$175.94	\$373.16	\$4.66	38						
		\$348.49	\$523.04	\$157.12	\$9.10	8						
		\$741.96	\$848.62	\$4,448.52	\$15.86	151						
		\$2,088.96	\$1,082.65	\$3,603.99	\$51.38	367						
		\$5,019.60	\$12,447.54	\$7,865.92	\$149.52	534						
		\$3,554.38	\$1,251.14	\$3,802.35	\$105.88	242						
		\$1,044.14	\$414.92	\$805.25	\$27.27	41						
		\$4,230.00	\$1,123.20	\$5,599.13	\$126.00	240						
		\$4,825.31	\$2,007.60	\$2,356.83	\$126.00	60						
		\$225.31	\$195.00	\$510.65	\$6.71	65						
		\$396.56	\$135.00	\$353.52	\$11.81	45						
		\$141.00	\$24.00	\$62.85	\$4.20	8						
		\$10,138.88	\$19,612.75	\$932.91	\$249.38	95						
		\$5,741.31	\$6,176.94	\$756.15	\$33.69	77						
		\$3,274.91	\$6,750.00	\$147.30	\$21.00	30						
		\$7,869.27	\$6,312.18	\$5,970.64	\$205.49	114						
		\$66,985.59	\$102,155.33	\$48,134.34	\$1,643.42	\$475.84						
		\$217,275.27										
units		293										
time		0.5										
	set interval		6981.83		readiness							
	oil analy		428.24		\$134,000.00							
	oil drums		6553.59									
	1 abso drum		119.16									
	abso cost		\$4,766.24	COR	INST MON							
				\$13,181.43	\$11,589.45							

THIS PAGE INTENTIONALLY LEFT BLANK

## LIST OF REFERENCES

1. Department of the Army, *Army Regulation (AR) 750-1, Army Maintenance Policy and Retail Maintenance Operations*, Washington, D.C., 1 Aug 94.
2. Department of the Army (DA), *DA Pamphlet (PAM) 738-750, Functional Users Manual for the Army Maintenance Management System (TAMMS)*, Washington, D.C., 1 Aug 94.
3. Department of the Army, *Technical Manual (TM) 38-301-1 Introduction, Theory, Benefits, Customer Sampling Procedures, Program and Reports*, Washington, D.C., 1 Sept 90, with change 3 dated 1 Sept 1996.
4. Department of the Army, *TM 38-301-2, Spectrometric and Physical Test Laboratory Operating Procedures and Requirements*, Washington, D.C., 1 Jun 89, with change 5 dated 1 Sept 1996.
5. Department of the Army, *TM 38-301-3, Laboratory Analytical Methodology and Equipment Criteria (aeronautical)*, Washington, D.C., 1 Sept 90.
6. Department of the Army, *TM 38-301-4, Laboratory Analytical Methodology and Equipment Criteria (Nonaeronautical)*, Washington, D.C., 1 Sept 87, with change 5 dated 1 Sept 1996.
7. Army Material Command (AMC), *AMC-R 11-47, Army Oil Analysis Program*, Alexandria, VA, 17 Feb 95.
8. Department of the Army, *AR 700-132, Joint Oil Analysis Program (JOAP)*, Washington, D.C., 5 Dec 90.
9. Lin, James, Program Manager, Army Oil Analysis Program, Telephonic Interviews, Redstone Arsenal, AL.
10. Martin, Don, Contracting Officers Representative for Oil Analysis Laboratory, Telephonic Interviews, Fort Hood, TX.
11. Viscusi, W. Kip, "The Value of Risks to Life and Health", *Journal of Economic Literature*, vol. XXXI, pp. 1912-1946, December 1993.

12. Doyle, Randy, Pollution Prevention Specialist, Directorate of Public Works, Telephonic Interviews, Fort Hood, TX.
13. Naegle, Brad, Instructor Naval Postgraduate School, Personal Interviews, Monterey, CA.
14. Department of the Army, *Technical Bulletin (TB) 43-0211, AOAP Army Oil Analysis Program Guide for Leaders and Users*, Washington, D.C., 4 June 1998.
15. Gamble, Joseph, Operations research Analyst, Office of the Deputy for Cost Analysis and Director, Cost and Economic Analysis Center (CEAC), Telephonic Interview, Arlington, VA, 10 May 2000.
16. Department of the Army, *TM 10-6640-233-10, Operator's Manual for AOAP Mobile Laboratory Semi-Trailer Mounted*, Washington, D.C., 26 Oct 1990.
17. Morrow, Bonnie, Reserve Officer, Individual Mobilization Augmentee Program, Office of the Deputy Chief of Staff, Logistics (ODCSLOG), U.S. Army Europe (USAEUR), *Economic Analysis of AOAP for Ground Systems*, 17 Sept 1998.
18. Hannah, Robert, Previous Company Commander, M1 Company, Personal Interview, Monterey, CA.
19. Dooley, Tom, Logistician, PMO, Mobile Electric Power (MEP), TACOM, E-mail, Fort Belvoir, VA.
20. McElroy, Dan, Oil Analysis Management Specialist, PMO, AOAP, Personal Interview and Letters, Redstone Arsenal, AL.
21. Rodriguez, Elizabeth M., Deputy Regional Environmental Counsel for the Air Force Legal Services Agency, Environmental Division Eastern Region, Telephonic Interview, Atlanta, GA, 17 May 2000.
22. 3<sup>rd</sup> Signal Brigade, III Corps & Fort Hood, *Fort Hood Telephone directory*, March 2000.
23. U.S. Army CEAC, *The Army Military-Civilian Cost System 98 (AMCOS 98)*, version 00.01, Developed by SRA International, Inc., 1998.
24. Department of the Army, U.S. Army CEAC, *Cost Analysis Manual*, Falls Church, VA, July 1997.

25. Defense Logistics Support Command, Electronic Mail, [<http://www.emallmom01.dla.mil/scripts/default.asp>], May 2000.
26. McInerey, Jody, Logistician, PMO, LTV, TACOM, E-mail, Warren, MI.
27. Gaglio, Ceasar, Logistician, PMO, HTV, TACOM, Telephonic Interview and E-mail, Warren, MI.
28. Tarczynski, Marcia, Logistician, PMO, M1 Abrams, TACOM, E-mail, Warren, MI.
29. Wozniak, Gerald, Logistician, PMO, M2 Bradley, TACOM, E-mail, Warren, MI.
30. Hauser, Bill, Fleet Planning Office, TACOM, E-mail, Warren, MI.
31. Santos, Jose, Logistician, PMO, MEP, TACOM, E-mail, Fort Belvoir, VA.
32. Sweeney, William, Logistician, PMO, Construction Equipment, TACOM, Telephonic Interview and E-mail, Warren, MI.
33. Burden, Mark, Logistician, PMO, M113, TACOM, Telephonic Interview, Warren, MI.
34. Kandrot, John, Logistician, PMO, MTV, TACOM, Telephonic Interview, Warren, MI.
35. U.S. Army CEAC, "Revised Discount Rates for Use in Economic Analyses", [<http://www.ceac.army.mil>], May 2000.
36. Taylor, George A., *Managerial and Engineering Economy*, Third Edition, pp. 26-39, Prindle, Weber & Schmidt, 1980.
37. Department of the Army, *TM 10-3930-643-20, Maintenance Instructions Organizational Maintenance, Truck, Forklift, DED Pneumatic Tire, 10,000 LB. Capacity Rough Terrain, Articulated Frame Steer (Dresser Industries Model M10A, MHE 236)*, Washington, D.C., January 1990.
38. Mauldin, JB, Chief of Maintenance Operations, Director of Logistics, Telephonic Interview, Fort Hood, TX, 15 May 2000.

39. Roby, Steve, Reporting Instructor, School of Aviation Safety, Personal Interview, Monterey, CA.
40. Gibbs, Dorothy, Logistician, PM Tactical Vehicles, TACOM, E-mail, Warren, MI.

## INITIAL DISTRIBUTION LIST

1. Defense Technical Information Center.....2  
 8725 John J. Kingman Road, Ste 0944  
 Fort Belvoir, Virginia 22060-6218
2. Dudley Knox Library.....2  
 Naval Postgraduate School  
 411 Dyer Road  
 Monterey, California 93943-5101
3. Defense Logisitc Studies Information Exchange.....1  
 U.S. Army Logisitics Management College  
 Fort Lee, Virginia 23801-6043
4. Mr. John Weaver .....2  
 USA, TACOM  
 Bldg 210  
 AMSTA-LC-AF-PW  
 Warren, Michigan 23801-6043
5. Commander.....2  
 USAMC Logistics Support Activity  
 ATTN: AMXLS-LA, Bldg 3627  
 Redstone Arsenal, AL 35898-7466
6. Power Generation .....1  
 10115 Gridley Road  
 Suite 228, Bldg 324  
 Fort Belvoir, Virginia 22060
7. MAJ Dan Guilford.....2  
 PM, MCD  
 10205 Burbeck Rd  
 Fort Belvoir, Virginia 22060
8. LTC Brad Naegle.....1  
 Code SM  
 Naval Postgraduate School  
 Monterey, California 93943

9. Prof. Bill Gates .....1  
Code SM  
Naval Postgraduate School  
Monterey, California 93943